



## TRANSVERSE SLAB REINFORCEMENT DESIGN OF CONCRETE BRIDGE DECK: A REVIEW

Najiyu Abubakar<sup>1</sup>, Redzuan Bin Abdullah<sup>1</sup>, Ahmad Beng Hong Kueh<sup>1,2</sup> and Mohamad Salleh Yassin<sup>1</sup>

<sup>1</sup>Department of Structures and Materials, Faculty of Civil Engineering, Universiti Teknologi Malaysia, UTM Johor Bahru, Malaysia

<sup>2</sup>Construction Research Centre (CRC), Institute for Smart Infrastructure and Innovative Construction (ISIIC), Universiti Teknologi Malaysia, UTM Johor Bahru, Malaysia

E-Mail: [najiyuaj@gmail.com](mailto:najiyuaj@gmail.com)

### ABSTRACT

This paper reviews the current design practices of transverse slab reinforcement design in concrete bridge deck, which consist of concrete deck slab on wide concrete T-beams. The conventional bridge design method results in the provision of excessive transverse steel reinforcement in the concrete bridge deck slab due to the fact that, the slab is assumed to bear the applied vehicular loadings alone without considering the contribution of the wide T-beam flanges. Thus, the design which is based on bending and failure proved to be too conservative. Through critical review, issues regarding some design approaches were discussed. It has been found that, designing the deck slab in transverse direction would enable the vehicle wheel loads to be supported by the wide T-beam flanges and performance enhancement can be achieved by compressive membrane action resulted from the natural stiffness of the wide girder flanges. The presence of this membrane forces provides a punching shear capacity, which is far beyond the flexural design capacity for the new bridge deck system. This capacity would result in substantial reduction of the transverse reinforcement within the slab.

**Keywords:** T-beam, compressive membrane action, punching shear, transverse- reinforcement, bridge deck slab.

### INTRODUCTION

There are various bridge deck types but cast-in-place decks supported by concrete T-beam girders are popularly used in practice [1]. These cast-in-place concrete bridge decks are extensively used due to various factors. The factors include reasonable cost and availability of materials but, they have a serious problem of rebar corrosion. Some measures are taken to minimize this corrosion, like using an increased cover, application of sealants on the deck slab or use of galvanized/epoxy coated reinforcement, all of which do not provide a resistance to concrete cracking that usually cause the damage [2]. As bridge cost is by far higher than that of roads, it become necessary to have a proper planning for the best utilization of funds for transportation network [3]. This planning can be achieved by the use of best design method. Though good planning and design of bridges shows the innovation, imagination and exploration of designers [4, 5], but it is only possible when the design method itself is sound.

There exist various bridge deck slab design methods and some developed modified approaches in practice. The aim of this paper is to review and discuss these methods in order to highlight their suitability and eventually, propose an alternative approach that would provide an additional advantages like, substantial cost reduction, easier application and expected wider acceptance. Bridge deck slabs are popularly design using conventional method which resulted in the use of large amount of steel reinforcement. Other research developments to be discussed in this paper like, the empirical design method, UK BD 81/02 and steel free bridges showed that the conventional method is quite conservative because, of the existence of some additional phenomenon enhancing the strength capacity of the deck slab. The phenomenon referred to as compressive

membrane forces or arching action present in slab with some degrees of restraint have shown to have substantially increase the slab ultimate capacity far beyond the estimated value obtained by flexure. New design rules were then included in some bridge design specifications particularly the empirical design method of Ontario Highway Bridge Design Code and United Kingdom bridge design code taking in to account the effect of this arching action. The new rules provided more economical use of steel reinforcement within the deck slab. With the use of this reduced steel reinforcement, reinforced concrete deck slabs still require constant maintenance due to corrosion of the reinforcing steel caused by de-icing salts, temperature/thermal cracking of concrete and shrinkage; attention is then focused on the use of fiber reinforced polymers (FRP) in place of steel on one hand while, on the other hand some researches (to be discussed later in this paper) were engaged on the use of steel-free bridge deck slabs. But all the aforementioned methods have some peculiar disadvantages of higher costs and limited acceptance by designers. It is imperative therefore, to emphasize on possible means of improving the transverse slab deck design in order to limit such problems. This study would also consider the possible means of utilizing the transverse behaviour of beam and slab bridges in which the top slab would be designed transversely as one-way spanning supported by the longitudinal beams, taking in to account the lateral stiffness of the beam and its confining effect on the slab, beam flange stiffness and web thickness contributions. The various design method are summarily reviewed. The first being the conventional design method and a comparative capacity enhancement from arching action.

### CONVENTIONAL DESIGN METHOD AND ARCHING ACTION



The conventional flexural design method of bridge deck slab led to the use of high level of steel reinforcement to withstand the assumed flexural bending and failure. But the realization of arching action led to new design specifications.

### Conventional design method

Traditionally, concrete slab on girder bridges design is carried out with the assumption that the deck slab act as continuous beam spanning across a rigid girders. Using the assumption, moments are determined and used in the design of the deck slab, this method popularly known as "approximate strip design method" has been modified and adopted in AASHTO-LRFD specifications[6].

Majority of these concrete slab on girder bridges specifications are reported to have been developed in 1940s [7]. The most popular being the AASHTO's specifications resulted from some good researches that predicted pure flexural ultimate strength capacity of the slab deck [8, 9,10,11,12,13,14]. While in some other development, tests results for ultimate strength on some old bridges designed using the specification revealed that, they are by far stronger than the AASHTO rating [15, 16]. This development hints on the possibility of some other mechanisms providing the enhancement. In a nutshell, the existence of compressive membrane forces within the deck slab produces a substantial reserve capacity far beyond its flexural design capacity and rather led to a punching failure mode.

Compressive membrane forces/Arching action originally observed by Westergard and Slater [8] after which some tests results on old slabs[15,16] gave a collapse load far beyond those obtained from yield-line theory [17]. Further studies have then carried out in developing arching action theories for both one way and two way slabs [18,19,20,21,22,23,24,25,26,27]. Valipouret al. [28] explained that the axial strain occur when the tensile zone crack, making the neutral axis moves towards the compressive fibre as a result of beam or slab deflection. The prevention of this strain by end restraint as shown in Figure-1 which produces a compressive membrane forces in the member enhances the capacity of that member, which leads to empirical method of design [29, 30]. It has also being fund out that, members with lower span to depth ratios have higher arching action behaviour due to their higher compressive strength and accompanying crushing strain [31-38]. The use of minimum steel percentage in restrained slabs reduces maintenance cost, increase durability and enhanced Punching shear capacity [39]. Meanwhile the Ontario Highway code incorporates the use of this arching action. Compressive membrane forces also exist in edge stiffened cantilever overhang of a bridge deck as failure pattern obtained was different from that of pure flexure when subjected to static loads simulating wheel loads [40]. A popular arching action application has also been reported in bridge deck assessments [35]. Arching action have long been found to increase the concrete slab carrying capacity in comparison with that obtained using only flexural

theory [41,42]. Csagoly and Lybas [43] noticed that the presence of arching action within the slab of restraint boundary preventing deformation under the action of concentrated load immensely enhanced the slab ultimate strength far beyond that specified by flexure theory. Barker and Pucket [44] also stated that empirical design method utilizes the full action of internal arching in which the bottom reinforcement served as tensile tie to compressive strut at the top of the deck subjected to load. Meanwhile, the concrete also provide additional aid to the system which in turn enables the reduction of overall reinforcement to about 40-65%. With this economy from the use of reduced reinforcement steel, many highway agencies preferred to use the empirical method. However, immediate cracks formation have been noticed in many USA bridges [45, 46,47,48,49,50,51] prior to opening to traffic, though there is no any evidence that the system would resist other load combinations like thermal and shrinkage stresses.

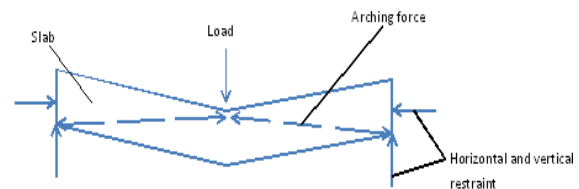

**Figure-1.** Arching action in horizontal and vertical restrained slab.

Petrou and Perdikans [52] reported that total deflection of bridge deck is not really flexural but also highly influenced by small girder spacing and/or large deck thickness. Mufti *et al.* [53] reckoned that internal arching action may also be present in bridge deck cantilever overhangs under the action of concentrated load. This was then experimentally studied by Klowaker *al.*[54], where, the tests results for the ultimate load capacities were far greater than those for pure flexural mode of failure. Some other researchers also revealed that restrained reinforced concrete deck under the action of concentrated wheel loads exhibit a punching shear failure mode not flexure as expected by conventional design method [55,56]. However, Hewitt and Batchelor [55] further stated that for restrained slab, the wheel load would not be resisted by reinforcement due to the effect of compressive membrane action similar to that present in reinforced concrete beam. Park and Gamble [57], Graddy *etal.* [58], and Zheng *et al.* [59] deduced that this type of failure is commonly present in thick slab with restrained boundary.

### Empirical design method

An empirical design method of isotropic bridge decks was developed in late 1970's which is based on the assumption that the deck slab uses arching action between the girders in resisting the loads [60]. More practical approach is adopted in the North America following the



works on compressive membrane action by various researchers in 1970s [61, 62]. The findings from field tests enables the inclusion of an empirical design method in to the Ontario Highway Bridge Design Code in 1979 [63]. The method requires only a minimum isotropic reinforcement of 0.3% within the deck slab.

### UK Bridge deck design

New design approach proposed by Kirkpatrick, Rankin and Long [64] which was validated by full-scale bridge test in 1986 [65] prompted the initiation of new rules for economical design of reinforced concrete bridge decks in the Northern Ireland [66]. The approach was then included in the roads and bridges design manual, BD 81/02 'Use of Compressive Membrane action in Bridge Decks' by the United Kingdom Highway Agency [67].

### Steel-free bridges

At Dalhousie University, Halifax, Nova Scotia Canada, a study have been conducted where, a great breakthrough in bridge design which concluded that, providing a bridge deck on longitudinal girders can be confined in both longitudinal and transverse direction, steel reinforcement is totally not desirable [68]. Studies have been carried out on a number of this steel-free deck slabs consisting of five half scale and six full scale models under the action of static loads [69, 70, 71]. After which, some other precast steel-free deck panels were constructed and tested in the same manner [70]. The studies have been supported by formulating a rational model for predicting the strain and deflection relationships with the applied load and eventual load capacity of the system [72]. The pioneer highway steel-free bridge (Salmon River bridge) have been constructed in 1995 [73] which was studied under the action of heavy traffic volumes and almost daily freeze-thaw cycles in winter, have been found to be performing as required. One of the drawbacks of this method is the attainment of confinement at the end of the deck because; a special and stiff edge beam has to be provided to attain the desired restraint. Another drawback is the formation of longitudinal cracks parallel to the girders running midway between them for the entire deck slab length. To solve the problem of this crack formation, significant studies have been carried out on the use of fiber reinforced polymer in the concrete deck slab [74-81].

### Use of Fibre Reinforced Polymer (FRP)

Among the serious courses for maintenance in bridges is the corrosion of reinforcement which leads to the deterioration of the concrete; use of FRP is among the possible solution to this problem [82]. Use of FRP in place of reinforcing steel is successfully practiced [83, 84]. Meanwhile using the fibre with some content of polymeric resin has also carried out by Yost and Schmeckpeper [85]. Good laboratory and field results for such systems have been obtained by Benmokrane *et al.* [86]. In another study, FRP gratings were used as reinforcement [87]. Studies on this FRP in slab deck and FRP girders have then continually carried out and a lot of contributions have been provided by many researchers [88-94].

### DISCUSSIONS

After the review of previous researches, it becomes clear that more economical design method for transverse reinforcement in concrete bridge deck slab is needed. Summary of various design methods is presented in Table-1. It can be seen that, the conventional design method is very conservative as it assumed a flexural deck slab behaviour without considering any other factor that might enhanced its ultimate strength capacity. Subsequent methods incorporate arching action behaviour that enhanced the slab deck strength capacity and results in the use of reduced amount of reinforcement. The innovation of steel-free slab decks shows that, steel reinforcement could be totally removed provided a sufficient restraint to utilize arching action can be achieved. On the other hand, all these methods have some peculiar disadvantages for example, the conventional design method require a higher budget meanwhile, the provision of larger amount of reinforcement have a greater chance of corrosion and eventual deterioration of the bridge. Methods for epoxy coating of reinforcement for durability enhancement [95,96], also proved to be costly. Existence of cracks in the remaining methods reveals that some measures need to be taken. Meanwhile use of FRP as anti-cracks and external steel straps in steel-free bridges make them more expensive.

Designs in Wisconsin for bridge deck are carried out using the approximate method [97] though; WisDOT Bridge manual stated the performance of empirically designed bridge decks including Ontario design deck [98]. These Bridges performed satisfactorily with reduced amount of reinforcement. Bridges constructed on the newly formed wide flanged beams apparently have higher ultimate capacity more especially those with additional lateral restraint that developed arching action [99]. Very few numbers of steel-free bridges were constructed in the world. Five steel free bridges were constructed in Canada with the first being Connestogo River bridge constructed in 1975. The steel-free design method is observed to have had a lesser practical acceptance considering the few number of bridges designed and constructed using the method.

### ON-GOING RESEARCH

Considering the un-resolved issues discussed above, and to base the argument on a more scientific basis a study of bridge deck slab on wide concrete T-beams is underway. The study is intended to include the girder web stiffness and the T-beam wide flange area in enhancing the carrying capacity of the slab deck. Considering the fact that Bougerraet *et al.* [100] obtained a good punching shear strength on some tested samples, the values obtained are much greater than the current ACI 440.1R-06 [101] punching shear model and also 1.74-3.52 times the Canadian Highway Bridge Design Code factored load; More recently, Beatrice *et al.* [102]. Obtained load values of at least 333kN on some tested slab specimens which is by far greater than the maximum load of 112.5kN of the BD 81/02. Other researches like Moradi *et al.* [103] proved the same argument; it become clear that an



improvement on the empirical design philosophy and the likes is needed. New design method that would incorporate the effect of additional carrying capacity of bridge deck from the stiffness of T-beam elements should be explored. Investigation in to the restraining ability of the slab deck and beam web producing a substantive arching action should be carried out too. The current research study would use minimum anti-cracks steel in the slab. The slab of which is supported by a closely spaced wide T-beam prestressed concrete girders as shown in Figure-2 in accordance with some existing designed and constructed case-study bridges. Vehicular load model 1

Tandem system of Eurocode [104] would be adopted in the study. As the clear space between adjacent girder flanges is short (50,200 and 500mm), the vehicle wheel load would be directly supported by the prestressed concrete girders considering the fact that the vehicular wheel contact area is 460×460mm [105]. The surface of the T-beam would be rough and wet prior to the application of the top slab so as to obtain a better performance [106]. The ultimate goal is to achieve a more economical design approach for slab-on-concrete girder bridges.

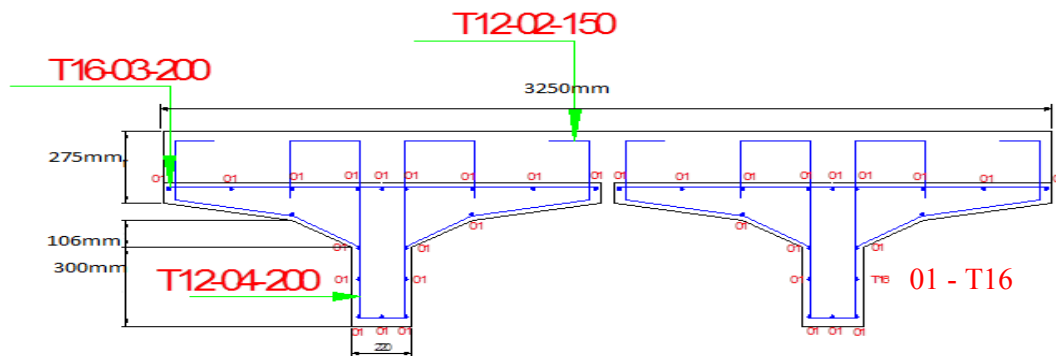

Figure-2. Slab on wide-flanged and closely spaced girders.

Table-1. Summary of concrete slab-on Girder Bridge design methods.

S. No.	Method	Application example	Techniques	Results	Other factors	Remark
1	Conventional	General	Approximate strip design method of deck slab supported by center points of girders	Use large amount of steel reinforcement	Possible use of diaphragm beams	Highly conservative
2	Empirical	North America-Ontario Highway Bridge Design Code	Utilizes the presence of compressive membrane forces	Use 0.3% minimum isotropic reinforcement	Diaphragm beams might be used	Substantive amount of reinforcement use; formation of immediate cracks in some bridges prior to opening
3	UK approach Compressive membraneAction	UK Design manual for Roads and Bridges, BD81/02	Utilizes the presence of compressive membrane forces	Substantive reduction of steel reinforcement use	Diaphragm beams might be used	Use of steel reinforcement in the slab liable to corrode.
4	Steel-free deck slab	Canada, USA	Full arching action achieved from additional external restraint	Bridge deck slab without any internal steel reinforcement	Use of external horizontal steel rods/straps. Use of FRP as anti-cracks within the slab deck	Formation of longitudinal cracks between girders which necessitates the use of FRP as antic racks in the deck slab
5	Alternative method	On-going research	Use of wide flanged closely spaced concrete T-beam girders	Use of anti-cracks steel reinforcement	Use of smaller clear space between girder beam flanges less than the vehicle wheel contact area	Use of anti-cracks reinforcement in the slab. Full utilization of concrete T-beam flanges

## CONCLUSIONS

Paper reviewed the existing design approaches of transverse steel reinforcement in concrete slab-on girder

bridges from which the following conclusions can be drawn:



- Conventional design method resulted in the provision of high amount of reinforcement which increases the chances of corrosion occurrence and eventual deterioration of the deck slab.
- Formation of cracks in empirical design methods hinder its applicability.
- Use of FRP as anti-cracks and provision of external steel straps in steel-free deck slab increase the total cost of the bridge.
- Use of T-beam geometries like, wide beam flange and web thickness might greatly enhance the carrying capacity of the top slab and possible reduction in the bridge overall cost.

#### ACKNOWLEDGEMENT

The authors thank the Malaysian Ministry of Higher Education (MOHE) and Universiti Teknologi Malaysia (UTM) for research grants (O.J130000.2522.10H55, R.J130000.7809.4L098 and R.J130000.7809.4F518) and facilities. The first author also appreciates the support of Kano University of Science and Technology Wudil and Tertiary Education Trust Fund (TETFUND) Nigeria.

#### REFERENCES

- [1] Trilok G. and Anurag M. 2007. Effect on support reactions of T-beam skew bridge decks, ARPN Journal of Engineering and Applied Sciences. 2(1): 1-8.
- [2] Wai-Fah Chen. 2000. Bridge Engineering handbook. CRC Press Boca Raton London New York Washington, D. C.
- [3] Richard M. Barker and Jay A. Pucket. 2007. Design of Highway Bridges. An LRFD approach 2nd edition. John Wiley & Sons Inc, Hoboken, New jersey. p. 2.
- [4] Waddell J. A. L. 1916. Bridge Engineerin. Vol. 1, John Wiley & Sons, New York. 267-280.
- [5] Mitropolskii N. M. 1958. Methodology of Bridges Design, scientific-technical edition. Avtotransportni Literaturny, Moscow. 215-242
- [6] AASHTO LRFD Bridge Design Specifications 1994, American Society of State Highway and Transportation Officials, Washington, D.C.
- [7] Azizinamini A., Shekar Y., Boothby T.E. and Barinhill G. 1994. Old Concrete slab bridges II: Analysis. Journal of structural engineering ASCE. 120(11): 0011-3305.
- [8] Westergard H.M. and Slater W.A. 1921. Moments and stresses in slabs. Proc., 17 Annual Conventions, American Concrete Institute (ACI), Detroit, Mich. 415-538.
- [9] Westergard H.M. 1926. Stress in concrete pavements computed by theoretical analysis. Public Roads.7(2): 25-35.
- [10] Westergard H.M. 1930. Computation of stress in bridge slabs due to wheel loads. Public Roads.11(1): 1-23.
- [11] Newmark N.M. 1938. A distribution procedure for the analysis of slabs continuous over flexible beams. University of Illinois Publication, Urbana Ill. Bull. No. 304.
- [12] Jansen V.P. 1938. A distribution procedure for the analysis of slabs continuous over flexible supports. University of Illinois Publication, Urbana Ill. Bull. No. 304.
- [13] Jansen V.P. 1939. Moments in simple span bridge slabs with stiffened edges. University of Illinois Publication, Urbana Ill. Bull. No. 315.
- [14] Jansen V.P., Kluge R.W. and Williams C. B. Highway slab-bridges with curbs: Laboratory tests and proposal design method. University of Illinois Publication, Urbana Ill. 194. Bull. No. 3463.
- [15] Ockleston A.J. 1955. Load tests on a three storey building in Johannesburg. The Structural Engineer. 33,304-322.
- [16] Ockleston A.J. 1958. Arching action in reinforced concrete slabs. The Structural Engineer. 36(6):197-201.
- [17] Johansen K.W. 1962. Brudlinieteorier. Jul. GjellerupsForlag, Copenhagen. Yieldline theory. Translated by Cement & Concrete Association, London. 191.
- [18] Wood R.H. 1961. Plastic and elastic design of slabs and plates. Thames and Hudson, London.
- [19] Christiansen K.P. 1963. The effect of membrane stresses on the ultimate strength of an interior panel in a reinforced concrete slab. The Structural Engineer. 41(8): 261-265.
- [20] Leibenberg A.C. 1966. Arch action in concrete slabs. National Building Research Institute Bulletin, CSIR Research Report, Pretoria, S. Africa. 40: 234.



- [21] Park R. 1964. Ultimate strength of rectangular concrete slabs under short-term uniform loading with edges restrained against lateral movement. *Proceedings Instn. Civ. Engrs.* 28:125-150.
- [22] Park R. and Gamble W.L. 1980. Reinforced concrete slabs. Wiley Interscience, New York. 562-612.
- [23] American Concrete Institute 1971. Cracking, deflection and ultimate load of concrete slab systems. Detroit. 30:382.
- [24] Braestrup M.W. 1980. Dome effect in reinforced concrete slabs: rigid-plastic analysis. *J. Struct. Div., Proc Am. Soc. Civ. Engrs.* 106(ST6):1237-1253.
- [25] Braestrup M.W. and Morley C.T. 1980. Dome effect in reinforced concrete slabs: elastic-plastic analysis. *J. Struct. Div., Proc Am. Soc. Civ. Engrs.* 106(ST6):1255-1262.
- [26] Lahlouh E.H. and Waldron P. 1922. Membrane action in one-way slab strips. *Proc. Instn. Civ. Engrs, Structs & Bldgs.* 94:419-428.
- [27] Kuang J. S. and Morley C. T. 1993. A plasticity model for the punching shear of laterally restrained concrete slabs with compressive membrane action. *International Journal of Science.* 35(5):371-385.
- [28] Valipour H, FarhangVesali N, Foster S. 2013. A generic model for investigation of arching action in reinforced concrete members. *Constr Build Mater.* 38:742-50.
- [29] Taylor SE, Rankin B, Cleland DJ, Kirkpatrick J. 2007. Serviceability of bridge deck slabs with arching action. *ACI Struct J.* 104:39-48.
- [30] Rankin GIB, Long AE. 1997. Arching action strength enhancement in laterally restrained slab strips. *ProcInstCivEng: Struct Buildings.* 122:461-7.
- [31] Brotchie JF, Holley MJ. 1971. Membrane action in slabs, cracking, deflection, and ultimate load of concrete slab systems. *ACI Special Publication.* SP-30.
- [32] Christiansen KP, Fredriksen VT. 1983. Experimental investigation of rectangular concrete slabs with horizontal restraints. *Mater Struct.* 16:179-92.
- [33] Guice LK. 1986. Behavior of partially restrained reinforced concrete slabs. US Army Engineer Waterways Experiment Station, Vicksburg, MS. SL-86-32
- [34] Guice LK, Rhomberg EJ. 1988. Membrane action in partially restrained slabs. *ACI Struct J.* 85:365-73.
- [35] Lahlouh EH, Waldron P. 1992. Membrane action in one-way slab strips. *ProcInst Civ. Eng, Struct Buildings.* 94:419-28.
- [36] Taylor SE, Rankin GIB, Cleland DJ. 2001. Arching action in high-strength concrete slabs. *ProcInstCivEng: Struct Buildings.* 146:353-62.
- [37] Ruddle ME, Rankin GIB, Long AE. 2002. Arching action - flexural and shear strength enhancements in rectangular and Tee beams. *Struct Buildings.* 156:63-74.
- [38] Bazan M. 2008. Response of reinforced concrete elements and structures following loss of load bearing elements. PhD dissertation. DeptCiv Environ Eng. New York: MacMillan.
- [39] Chana PS, Desai SB. 1992. Membrane action and design against punching shear. *The Structural Engineer.* 70(19).
- [40] Ontario Highway Design Code, 1983. Ontario Ministry of Transportation and Communication. Ontario, Canada.
- [41] Klowak C. Mufti A and B. Bakht. Examining the Presence of Arching Action in Edge-Stiffened Bridge Deck Cantilever Overhangs Subjected to a Wheel Load. *The Journal of Composites for Construction,* © ASCE; A4013001(9): 1090-0268.
- [42] Eyre JR. 1988. The use of membrane action in the strength assessment of corrosion-damaged RC bridge deck slabs. *Proceedings of the First International Conference on the Behaviour of Damaged Structures, Rio De Janeiro, Brazil.* 20-22 May.
- [43] Ockleston AJ. 1955. Load tests on a 3-storey reinforced concrete building in Johannesburg. *Struct Eng.* 33(10):304-22.
- [44] Ockleston AJ. 1958. Arching action in reinforced concrete slabs. *Struct Eng.* 36:197-201.
- [45] Csagoly P.F. and Lybas J.M. 1989. Advanced design method for concrete bridge deck slabs. *Concrete Int.* 11(5): 53-63.



- [46] Barker R. M. and Puckett J. A. 2007. Design of highway bridges: An LRFD approach, 2nd Ed., Wiley, Hoboken, NJ.
- [47] Owens F. T. and Alampalli S. 1999. In-service performance of HP concrete bridge decks. New York. State Dept. of Transportation, New York. Final Rep. FHWA/NY/SR-99/130.
- [48] Douglas N. E. 1997. Performance evaluation of isotropic bridge decks (Ontario design). Research and Technology Section, Materials and Technology Division, Michigan Dept. of Transportation, Lansing, MI. Research Rep. No. R-1352.
- [49] Xi Y., *et al.* 2003. Assessment of the cracking problem in newly constructed bridge decks in Colorado. Colorado Dept. of Transportation, Denver. Final Rep. No. CDOT-DTDR-2003-3.
- [50] Frosch R. J., Blackman D. T. and Radabaugh R. D. 2003. Investigation of bridge deck cracking in various bridge superstructure systems. Indiana Dept. of Transportation, Indianapolis. Final Rep. FHWA/IN/JTRP-2002/25.
- [51] Balmer D. M. and Ramey G. E. 2003. Effect of bridge deck thickness on properties and behavior of bridge decks. Pract. Period. Struct. Des. Constr. 8(2): 83-93.
- [52] Michael F. Petrou and Philip C. 1996. Perdikaris. Punching shear failure In Concrete Decks as snap-through instability. Journal of Structural Engineering. ASCE. 122(9): 0009-099.
- [53] Mufti A. A., Bakht B. and Jaeger L. G. 2008. Recent advances in bridge engineering, JMBT Structures Research, Scarborough, ON.
- [54] Klowak C., Mufti A. and Bakht B. 2013. Examining the Presence of Arching Action in Edge-Stiffened Bridge Deck Cantilever Overhangs Subjected to a Wheel Load Journal of Composites for Construction, ASCE. A4013001(9):1090-0268.
- [55] Hewitt BE, Batchelor de VB. 1975. Punching shear strength of restrained slabs. J StructDiv, ASCE. 10(9):1837-53.
- [56] Perdikaris PC, Beim S. 1988. RC Bridge decks under pulsating and moving loads. J StructEng, ASCE. 114(3):591-607.
- [57] Park R. and Gamble W. L. 2000. Reinforced concrete slabs, 2<sup>nd</sup>Ed. Wiley, New York.
- [58] Graddy J. C., Kim J., Whitt J. H., Burns N. H. and Klingner R. E. 2002. Punching-shear behaviour of bridge decks under fatigue loading. ACI Struct. J. 99(3): 257-266.
- [59] Zheng Y., Robinson D., Taylor S., Cleland D. and Shaat A. 2008. Analysis of compressive membrane action in concrete slabs. Institution of Civil Engineers, Bridge Eng. 161: 21-31.
- [60] AASHTO LRFD1994. Bridge Design Specifications, American Society of State Highway and Transportation Officials, Washington, D.C.
- [61] Hewitt B.E. and Batchelor B. de V. 1975. Punching shear strength of restrained slabs. J. Struct. Div., Proc. ASCE. 101(ST9):1837-1853.
- [62] Batchelor B. de V. and Tissington I.R. 1976. Shear strength of two-way bridge slabs. J. Struct. Div., Proc. ASCE. 102(ST12): 2315-2331.
- [63] The Ontario highway bridge design code 1979, Ontario Ministry of Transportation and Communication, Toronto, Ontario, Canada.
- [64] Kirkpatrick J., Rankin G.I.B. and Long A.E. 1984. Strength evaluation of M-beam bridge deck slabs. The Structural Engineer. 62B(3):60-68.
- [65] Kirkpatrick J., Rankin G.I.B. and Long A.E. 1986. The influence of compressive membrane action on the serviceability of beam and slab bridge decks. The Structural Engineer. (64B): 6-9 and 12.
- [66] Design of M-beam bridge decks to the Bridge Design Code. Department of the Environment, Northern Ireland., Northern Ireland Roads Service Headquarters, March 1986. (3): 11.1-11.5.
- [67] United Kingdom Highways Agency 2002. Use of compressive membrane action in bridge decks. Design Manual for Roads and Bridges. Vol. 3, Section 4, Part 20, BD 81/02.
- [68] Bakht B. and Agarwal A.C. 1995. Deck Slabs of Skew Bridges. Canadian Journal of Civil Engineering. 22(3):514-530.
- [69] Mufti A.A. and Newhook J.P. 1999. A Note on the use of Steel-Free Concrete Bridge Decks in



- Continuous Span Bridges. Canadian Journal of Civil Engineering. 26(5): 667-672.
- [70] Mufti A.A. and Newhook J.P. and Wegner L.D. 2000. The Importance of Understanding Punching Shear in Bridge Deck Slab Innovations. Proceedings of the International Workshop on Punching Shear Capacity of RC Slabs, Royal Institute of Technology, Sweden. 407-414.
- [71] Bakht B. and Lam C. 2000. Behaviour of transverse confining systems for steel-free deck slabs. ASCE Journal of Bridge Engineering. 5(2):139-147.
- [72] Mufti A.A. and Newhook J.P. 1998. Punching Shear Strength of Restrained Concrete Bridge Deck Slabs. ACI Structural Journal. 95(4):375-381.
- [73] Newhook J.P. and Mufti A.A. 1996. A reinforcing Steel-Free Concrete Bridge Deck for the Salmon River Bridge. Concrete International. 18(6):30-34.
- [74] Matsui S., Ishizaki S. and Kubo K. 1994. A study on FRP permanent form for reinforced concrete slabs. Technology Rep. Prepared for Osaka Univ., Osaka, Japan. 295-307.
- [75] Matsui S., Ishizaki S. and Kubo K. 2001. An experimental study on durability of FRP-RC composite deck slabs of highway bridges. Proc., 3<sup>rd</sup> Int. Conf. on Concrete under Severe Conditions: Environment & Loading, Vancouver, Canada. 933-940.
- [76] McCormick F. C. 1993. First traffic-bearing composite bridge was built in China. Civ. Eng. (N.Y.), XX. 35-35.
- [77] Zureick A., Shih B. and Munley E. 1995. Fiber-reinforced polymeric bridge decks. Struct. Eng. Rev. 7(3): 257-266.
- [78] Lopez-Anido R., Ganga Rao H. V. S., Troutman D. and Williams D. 1998. Design and construction of short-span bridges with modular FRP composite deck. Proc., 2<sup>nd</sup> Int. Conf. on Composites in Infra-structure, ICCI '98, Tuscon, Ariz. 705-714.
- [79] Reising R. M. W., *et al.* 2001. Performance of five-span steel bridge with fiber-reinforced polymer composite deck panels. Transportation Research Record 1770, Transportation Research Board, Washington, D.C. 113-123.
- [80] Karbhari V. M. 2003. FRP Bridge decks-From design and characterization to field implementation. Proc., European Bridge Engineering Conf.-Lightweight Bridge Decks, Rotterdam, The Netherlands.
- [81] Assessment of a Steel-Free Fiber Reinforced Polymer-Composite Modular Bridge System Journal of Structural Engineering 2005. ASCE; 131, 0733-9445//3-498-506.
- [82] Lijuan Cheng, Lei Zhao, Vistasp M. Karbhari, Gilbert A. Hegemier and Frieder Seible. 2005. Assessment of a Steel-Free Fiber Reinforced Polymer-Composite Modular Bridge System: Journal of Structural Engineering, ASCE. 131(3): 498-506.
- [83] Kumar S. V. and GangaRao H. V. S. 1998. Fatigue response of concrete decks reinforced with FRP rebars. J. Struct. Eng. 124(1):11-16.
- [84] Hassan T., Abdelraham A., Tadros G. and Rizkalla S. 2000. Fiber reinforced polymer reinforcing bars for bridge decks. Can. J. Civ. Eng. 27(5):839-849.
- [85] Yost J. R. and Schmeckpeper E. R. 2001. Strength and serviceability of FRP grid reinforced bridge deck. J. Bridge Eng. 6(6):605-612.
- [86] Benmokrane B., Masmoudi R., Chekired M., Rahmen H., Debbache Z. and Tadros G. 1999. Design, construction and monitoring of fiber reinforced polymer reinforced concrete bridge deck. Proc., 4th Int. Symp. on Fiber Reinforced Polymer Reinforcement for Reinforced Concrete Structures, American Concrete Institute, Detroit. 87-102.
- [87] Bank L. C., Yehoshua F. and Shapiro A. 1997. Three-dimensional fiber-reinforced plastic grating cages for concrete beams: A pilot study. ACI Struct. J. 94(6): 643-652.
- [88] Wasan I. K., Ikbali N. G. and Zeinab R. M. 2012. Behavior Of High Performance Fiber Reinforced Concrete Columns. ARPN Journal of Engineering and Applied Sciences. 7(11): 1455-1467.
- [89] Zureick A., Shih B. and Munley E. 1995. Fiber-reinforced polymeric bridge decks. Struct. Eng. Rev. 7(3):257-266.
- [90] Lopez-Anido R., Ganga Rao H. V. S., Troutman D. and Williams D. 1998. Design and construction of short-span bridges with modular FRP composite deck.





- Proc., 2nd Int. Conf. on Composites in Infra-structure, ICCI '98, Tuscon, Ariz. 705-714.
- [91] Reising R. M. W., et al. 2001. Performance of five-span steel bridge with fiber-reinforced polymer composite deck panels. Transportation Research Record 1770, Transportation Research Board, Washington, D.C. 113-123.
- [92] Karbhari V. M. 2003. FRP Bridge decks-From design and characterization to field implementation. Proc., European Bridge Engineering Conf.-Lightweight Bridge Decks, Rotterdam, The Netherlands.
- [93] Salim H. A. and Davalos J. F. 1999. FRP composite short-span bridges: Analysis, design and testing. J. Adv. Mater. 31(1):18-26.
- [94] Karbhari V. M., Seible F., Burgueno R., Davol A., Wernli M. and Zhao L. 2000. Structural characterization of fiber-reinforced composite short- and medium-span bridge systems. Appl. Compos. Mater. 7(2/3):151-182.
- [95] Vořechovská D., Tepl'y B., Somodíková M., Lehk'y D. 2015. Mod-elling of service life of concrete structures under combined mechanical and environmental actions. Modelling in Mechanics, Ostrava, Czech Republic. C-R: 13.
- [96] Bentz D.P., Garboczi E.J., Lu Y., Martys N., Sakulich A.R., Weiss J. W. 2013. Modeling of the influence of transverse cracking on chloride penetration into concrete. Cement Concrete Compos. 65-74.
- [97] AASHTO LRFD Bridge Design Specifications, 6th edition. American Association of State Highway and Transportation Officials, Washington, D.C. 2012.
- [98] Wisconsin Department of Transportation Bridge Manual. Chapter 17. Superstructure - General. Section 17.5. Design of Slab on Girders. January 2012.
- [99] Bae H.U., Michael G. O., Lawrence C. B. 2010. Obtaining optimal performance with reinforcement-free concrete highway bridge decks. Engineering Structures. 32: 2300-2309.
- [100] Bougerra K., Ahmed E. A., El-Gamal S. and Benmokrane B. 2011. Testing of full-scale Concrete bridge deck slabs reinforced with Fibre Reinforced polymer (FRP) bars. Construction and Building Materials, ASCE. 25: 3956-3965.
- [101] ACI Committee 440. Guide for the design and construction of concrete reinforced with FRP bars, ACI440, 1R-06, Farmington Hills (MI, USA). American Concrete Institute. 2006:41
- [102] Beatrice Belletti, Joost C. 2015. Walraven and Francesco Trapani. Evaluation of compressive membrane action effects on punching shear resistance of reinforced concrete slabs. Engineering Structures. 95: 25-39.
- [103] Moradi M., Valipour H., Foster S.J and Bradford M.A. 2016. Deconstructable steel-fibre reinforced concrete deck slabs with a transverse confining system. Materials and Design. 89: 1007-1019.
- [104] Eurocode BS EN 1992-1: Traffic loads on bridges 2003, 4.3.2(1) (b).
- [105] Bakht B., Aziz T. S. and Cheung M. S. 1979. Application of a Simplified Method of Calculating Longitudinal Moments to the Proposed Ontario Highway Bridge Design Code. Canadian Journal of Civil Engineering. 6(1): 365-50.
- [106] Ibrahim I.S., Elliott K.S., Abdullah R., Kueh A.B.H, Sarbini N.N. 2016. Experimental study on the shear behavior of precast concrete hollow core slabs with concrete topping. Engineering Structures. 125: 80-90.