

Available online at www.sciencedirect.com**ScienceDirect**

Procedia Engineering 180 (2017) 1495 – 1505

**Procedia
Engineering**www.elsevier.com/locate/procedia

International High- Performance Built Environment Conference – A Sustainable Built Environment Conference 2016 Series (SBE16), iHBE 2016

Occupancy profile variation analyzed through generative modelling to control building energy behavior

Andrea Zani^a, Lavinia C. Tagliabue^{b,*}, Tiziana Poli^a, Angelo L.C. Ciribini^b, Enrico De Angelis^a, Massimiliano Manfren^c^aPolitecnico di Milano, Department of Architecture, Built Environment and Construction Engineering, Via G. Ponzio 31, 20133, Milano, Italy^bUniversity of Brescia, Department of Civil, Environmental, Architectural Engineering and Mathematics, Via Branze 42, 25123, Brescia, Italy^cUniversity of Bologna, Department of Industrial Engineering, Viale del Risorgimento 2, 40136, Bologna, Italy

Abstract

Nowadays, building energy models use parametric analyses to optimize design strategies considering multiple variables. Integrated dynamic models combining design tool and visual programming language (VPL) and simulation tools to calculate building performance with BIM tool for the whole-building energy simulation have been adopted in the recent studies. Through these tools, it is possible to identify parametric systems, which become a “genome”, where a rapid comparison of different alternatives is possible through fitness criteria defined by design goals. The aim of the paper is to use this concept and the suitable parametric tools such as *Grasshopper* for *Rhinoceros* to handle variable hypotheses on users' occupancy that influence building energy performance. The paper focuses on occupancy variability applying the methodology to a university building located in northern Italy in the University of Brescia Campus to evaluate how generative modelling can represent an adequate approach to energy simulation of occupant behaviour. Sensors are now monitoring the real occupancy trend of the case study building and different scenarios defined in the parametric model could be compared to the real weekly. Using parametric tool and GA (Genetic Algorithms) can be analysed hundreds of occupancy patterns in order to better understand the influence of the occupancy on the building energy use and at the same time evaluate different strategies to save energy.

© 2017 The Authors. Published by Elsevier Ltd. This is an open access article under the CC BY-NC-ND license

[\(http://creativecommons.org/licenses/by-nc-nd/4.0/\)](http://creativecommons.org/licenses/by-nc-nd/4.0/).

Peer-review under responsibility of the organizing committee iHBE 2016

Keywords: Occupancy profiles; energy behaviour; parametric analysis; generative modelling

* Corresponding author. Tel.: +39 02 2399 6018; fax: +39 02 2399 6020

E-mail address: chiara.tagliabue@polimi.it

1. Introduction

The building sector is facing the challenge of enhance energy efficiency through envelope and plants renovation, achieving a reduced consumption during the operational phase [1]. The environmental, economic and social outcomes of these processes involve the greenhouse emissions (GHG) reduction by cost-optimal solutions [2][3]. Renovation can be approached by trivial solutions given by standard guidelines, however missing both environmental goals measured in CO₂ emission and final energy savings while not achieving substantial economic improvement. On the other hand, a deep intervention merging energy efficiency and strong use of renewables considered as an economically sustainable way, meeting CO₂ targets whereas presenting the lowest energy consumption and moreover offering a social improvement by a huge job creation potential could be obviously a preferred strategy [4]. The European target for environmental upgrading in the long-term connected to the building sector is a reduction of about 88-91% in 2050 compared to 1990 levels [5]. In order to accomplish this aim, the European countries need to deal with the performance assessment of the existing building stock and reduce its energy use in the long-term period [6] considering the uncertainties given in the prediction of the energy behavior of actual buildings [7]. Nevertheless, uncertainty in a number of factors burdens an efficient approach to energy retrofit of existing buildings and energy modelling and tuning actual performance to simulated ones to provide reliable energy saving scenarios [8] is crucial for cost-optimal interventions [9].

1.1. Accounting for occupancy variability

Modelling realistical building energy behavior is a key factor to optimize energy management practices during the building lifecycle. However, it meets barriers given by factors such as discrepancy between design and as-built data, simulation settings and real parameters, standard operation schedules and actual users' behavior, etc. [10]. The main key factors influencing the performance gap [11] are: for a) predicted performance: 1) design assumptions; and 2) modelling tools; for b) actual performance: 1) built quality; 2) occupancy behavior; and 3) management & controls systems. Occupants' behavior has a key role on the divergence between actual and predicted energy consumption [12][13]. Furthermore, studies based on statistical links between energy behavior and environmental constraints confirm that as the objectives of thermal comfort and energy savings clash, the user favors comfort losing the focus on energy efficiency [14][15]. Accordingly, occupants' behavior is one of the most remarkable and variable factor in the building energy performance estimation, challenging to forecast and to simulate appropriately [16]. The issues correlated to occupancy and adopted in energy modelling are derived in the first step of the research [17] from realistic dynamic patterns generated stochastically [18]. The data envelopment of the stochastic schedules is used to simulate the potential variability in daily and hourly energy consumption due to changing operational patterns and to highlight the "performance gap" with respect to standard simulation settings. The proposed modelling approach regarded an initial modelling phase, however it can be extended and validated during real time building operation, by implementing coherent performance monitoring and benchmarking practices [19]. The research work constitutes the starting point of a more general activity aimed at integrating inverse modelling techniques in current design practices for building retrofit. The accessibility of a calibrated and validated building energy model is central in propose accurate thresholds of efficiency. In fact, a proper analysis of the effect of occupants' behavior can be seen as an "occupant proofing" process, from building performance standpoint. In fact, modeling assumptions can turn into concerns, in terms of robustness and risk, when predicting future performance. This is especially significant in techno-economic viability assessments such as cost-optimal analysis [20][21] and life cycle cost (LCC) analysis [22][23][24], which are fundamental to delineate energy efficiency investments, or energy performance contracting (EPC).

1.2. Research field and application

The performance gap between energy forecast and actual consumption reaches dramatically high thresholds, as example, in University Campus buildings the difference can reach about +90% considering electricity, ranging to +130% including the thermal energy [25]. The environmental impact has been estimated in a +350% of CO₂ emission in comparison with the expected values. Wide-ranging studies and experimentations [26] work towards

bridging the gap (Fig. 1a), tuning the predictive models based on design data by actual metered data [27]. The performance gap casts questions about the application of physics principles, the difference between as-built/refurbished and theoretical/documental construction. The input data adopted to outline the building energy model [28] as well as the value of a continuous information chain [29] between building information model (BIM), updated documentation for management [30] and building energy model (BEM) [31] are broadly discussed key aspects. Given that, nowadays the detail of the BIM model from which to derive the analytical model suitable to be used to perform the energy analysis is a not fully unveiled issue [32][33]. Real data recorded by rationally installed sensors in the building permits definition of energy demand scattering (Fig. 1b) and to reveal relationships between factors and correlated influences. In a data-driven process the requirement of information is undeniable [34] and confirmation of the correct assumptions and simulation strategies could be endorsed with available monitored data. In the case study, the starting phase of recording validation [35] and tuning process [36] is at a starting point.

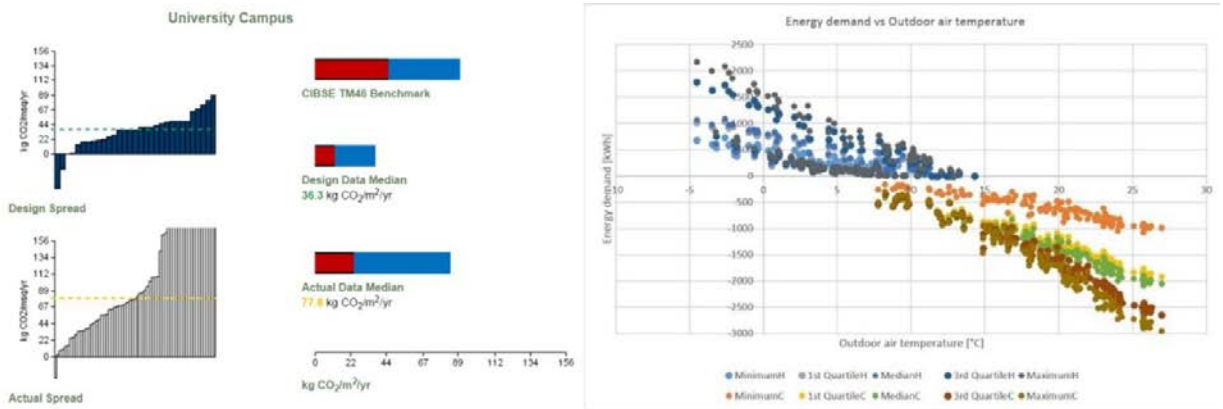

Fig. 1. CarbonBuzz benchmarking to promote energy efficiency and CO₂ reduction: data about University Campus energy benchmarking (a); Energy demand variability due to occupancy of the eLux Lab pilot building at University of Brescia Smart Campus (b).

The proposed methodology (Section 2) is applied to the eLUX Lab at the University of Brescia Smart Campus (Section 3), an educational building composed by three floors with computer laboratories, lecture rooms, an aula magna and an atrium as distribution zone used as preferred space for the individual study by the students. In this paper, thanks to the previous studies about energy consumptions and occupancy it is possible to evaluate the results obtained through VPL tools and develop a new model to simulate all the different cases generated by the occupancy uncertainty. Using GA is possible to define new usage strategy (classroom and lab usage) in order to minimize the energy demand maintaining the same users' number.

2. Materials and methods

The present study illustrates the application of a methodological approach to simulate building performance variability due to occupancy patterns for an education building. The performance modelling of this building presents relevant technical issues which are generally encountered in existing buildings (i.e. uncertainty in thermal characteristics, efficiency of technical systems, inadequate maintenance, high energy consumption, low level of internal environmental quality and highly variable and uncertain occupants' behavior). Researches discussed how to integrate software tools to achieve improvements in energy performance in the design process [37], in the present research two main approaches have been undertaken [38]:

- BIM used to support geometry definition in energy modeling BEM [39];

- Integrated dynamic models combine a design tool, a visual programming language (VPL) and a building performance simulation tool [40] and parametric analysis with the aim of optimization using genetic algorithms [41].

This latter approach has a dramatically powerful potential used in the early stage of design and renovation optioneering including the visual programming languages with 3D modeling tools for the improvement of passive design practices by showing alternatives and in some cases allowing optimize parameters. The growing diffusion of computational design, parametrization and contemporary definition of multi-scenario analyses lead to a novel need to code for designers and engineers in order to customize digital tools to achieve specific multi objective tasks. Anyway, the core issue is that this need owes a deep effort due to shared languages and knowledge and often the designer is not able to code and the communication in the teamwork of the project needs is not easily implemented by information technology or computer science experts [42].

2.1. Application of the VPL

The VPL is a method used by designer to change parameters of the project in order to optimize component and design choices oriented to specific targets. Visual Programming is a type of computer programming where users graphically interact with program elements instead of typing lines of text code. In the present work *Grasshopper* [43] has been used. In a Visual Programming environment, numbers, sliders, operators and functions, list manipulation tools, graphic creators, scripts, notes, customizable nodes and nodes for other developers (e.g. optimization components) are created. The nodes are hardwired effectively in the virtual environment to generate a structured system of relationships and reactions. The software tool *Grasshopper*, enabled by *Rhino 3D* is a current VPL in the building industry event though others (e.g. *Dynamo*) [44] show an emergent diffusion due to interoperability skill. Therefore, *Grasshopper* is able to interact with a number of simulation-based environmental plug-ins such as *Ladybug*, *Honeybee* for energy analysis and moreover includes components for single and multi-objective optimizations (i.e. *Galapagos* and *Octopus*).

2.2. Methodological workflow

The strategic method adopted in the research is developed by a workflow (Fig. 2) including the previous tools starting from the *EnergyPlus* model derived by the BIM model of the case study (Fig. 3 in section 3). Starting from previous steps of the research [45] a building energy model (BEM) to perform dynamic simulation have been realized by a SketchUp plug-in developed by Politecnico di Milano able the run of *EnergyPlus* calculation engine.

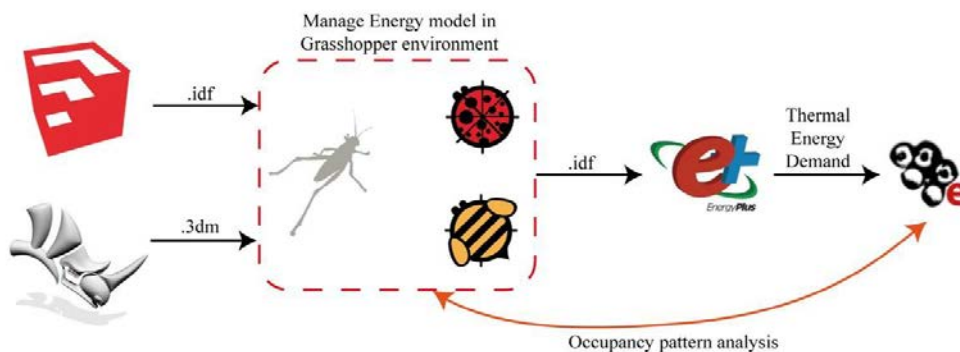

Fig. 2. General workflow adopted to manage energy optimization process in Grasshopper environment.

The *EnergyPlus* BEM model (i.e. idf file) has been introduced into *Rhino 3D* and the set-up has been refined into *Grasshopper* through *Ladybug* and *Honeybee* to fix the energy analysis features and then *Octopus* has been used to perform the occupancy pattern analysis by generative algorithms.

2.3. Genetic behavioral occupancy pattern analysis

The occupancy pattern analysis is based on the occupancy in the building: in the university campus building, the use of the classrooms is intensive however, the actual attendance to the lectures is at the starting point of the monitoring phase. The use of the spaces during the weekdays is regulated by the lectures schedule and in the present work the occupancy patterns have been simulated by changing randomly the attendance value with sliders going from the maximum people capacity of the classroom to the a minimum defined by a probabilistic behavioral approach (Table 2 in Section 3). After that, the associated energy demand has been compared (Section 4) and the whole cloud point of possible values of energy demand has been plotted. The possible values include the hypotheses of extended schedules of use of the building in summer period as required in the novel educational spaces approach pursued at national level [47] aiming at opening the campus to the surrounding community and promoting a self-sufficient energy and economic framework by social inclusion.

3. The case study: eLux Lab at University of Brescia Smart Campus, Italy

The case study is the eLux Lab at University of Brescia Smart Campus, Italy, is a ‘90s building used for lectures and informatics labs. The building aims to provide insights about smart control and optimized building management by detailed data acquisition and virtual environment (VE) modelling. The building is constituted by three floors with two computer labs located in the underground floor, two lectures spaces at the ground floor, an aula magna used for lectures and graduation days at the first floor and a glazed atrium (south-east façade). In Fig. 3 an external view of the building is shown (Fig. 3a) and the BIM model generated from geometric data captured with Terrestrial Laser Scanner (TLS) is shown in a screenshot of the users’ flow simulation (Fig. 3b), furthermore the BEM model in *Rhino 3D* with a coherent thermal zoning with the different space uses is shown (Fig. 3c).



Fig. 3. South-west and south-east façades of the eLux Lab at the University of Brescia Smart Campus, BIM model and BEM with thermal zoning.

3.1. Thermal zones setting

The building has been translated into a BEM with the geometrical and constructive thermal features derived by the previous step of the research and assuming the envelope characteristics in line with the age of the building as detailed documentation was lacking [45]. The building has four thermal zones with an occupancy schedule during the weekdays ranging between 7:00-19:00. In Table 1 the spaces and related thermal zone are described through the geometrical data (i.e. Dimensions), internal gains (i.e. Lighting and appliances and People) and losses (i.e. Ventilation) calculated on standard data based on the national scenario. The ventilation losses have been calculated according to the following formulas (1) and (2):

$$n = \frac{(v_{min} \cdot i_s \cdot A)}{V} \tag{1}$$

$$V_{a,k} = V \cdot n \tag{2}$$

where: n is the specific number of air changes [h^{-1}]; v_{min} is the specific external air flow required in the occupancy period [m^3/h per person] equal to $21.6 m^3/h$ per person; i_s is the density of occupants [$person/m^2$]; A is the surface area of the zone [m^2]; $V_{a,k}$ is the air flow rate required [m^3/h]; V is the net volume of the thermal zone [m^3].

The ventilation is thus calculated on the basis of the variable of number of occupants defined by the occupancy patterns (Section 3.2).

The internal gains are defined on the basis of a detailed survey of the equipment [17] of each room. The total amount of internal heat gains used in building energy simulation is related to the number of people (and their metabolic rate) and to the equipment (i.e. electric appliances and lighting). The internal gains due to electrical appliances (and the related energy consumption) are partially dependent on occupancy [18][46]. The values of the people gains can be calculated according to the following formulas (3):

$$Q_p = \frac{n_o \cdot M \cdot A_{DU}}{A} \quad (3)$$

where n_o is the number of occupants [-]; M is the metabolic heat [W]; A_{DU} is the DuBois corporal area for a standard person (e.g. equal to 1.8 m² for a 1.73 height and 70 kg male student); A is the surface area of the zone [m²]. The gains due to equipment (i.e. Lighting and appliances) are calculated as in the formula (4):

$$Q_{eq} = Q_l + Q_{app} = \left(\frac{P_{l,ind} + P_{l,dep}}{A} \right) + \left(\frac{P_{app,ind} + P_{app,dep}}{A} \right) \quad (4)$$

where $P_{l,ind}$ is the power in the zone lighting (e.g. security lighting | occupancy-independent) [W]; $P_{l,dep}$ the power in the zone for lighting (occupancy-dependent | connected to the operation of zones) [W]; $P_{app,ind}$ is the power for electrical appliances of the zone (e.g. beamer, sound, PC | occupancy-independent but connected to the operation of zones) [W]; $P_{app,dep}$ is the power for electrical appliances of the zone (e.g. laptops | occupancy-dependent) [W].

The amount of internal gains have been divided into user dependent and user independent considering some internal gains due to safety lights and constant loads of the lecture spaces (e.g. audio and video equipment) and variables related to equipment used by the students and burdening the standard energy consumption of the building and besides producing heat (e.g. laptop, mobile devices, etc.).

Table 1. Space of the building, thermal zones and geometrical and thermal balance specific data.

Location	Space	Zone	Dimensions		Lighting and appliances				People	Ventilation
			Area [m ²]	Volume [m ³]	User independent [W/m ²]		User dependent [W/m ²]		Gains [W/m ²]	Air changes [m ³ /h]
Floor	Name	n.	A	V	$P_{l,ind}$	$P_{app,ind}$	$P_{l,dep}$	$P_{app,dep}$	Q_p	Standard
Underground	MLAB1	1	151.8	455.4	0.76	60.95	15.22	18.22	39.84	1639
	MLAB2	1	207.9	623.8	0.76	60.95	15.22	18.22	42.59	2246
Ground	Atrium	2	178.3	534.8	1.40	1.58	28.01	1.98	33.46	1952
	MTA	3	177.5	532.4	1.28	2.50	25.68	5.93	101.78	1925
	MTB	3	180.8	542.3	1.28	2.50	25.68	5.93	102.23	1917
First	M1	4	337.5	1012.4	2.44	2.11	7.34	8.89	83.85	3645

The internal gains due to people vary considering the actual schedule of use of the building (i.e. lecture in a space and daily/weekly duration) however, approximation has been introduced: the hourly values in the weekdays are an average realized on the time slot (Table 2). In the weekends a constant occupancy related to the zone and specifically focused in the morning has been set.

3.2. Occupancy patterns simulations

As specified in the paragraph 2.1 a VPL methodology has been used, in particular the *Grasshopper* definition is divided in five main parts (Fig. 4): import and visualization of IDF file, internal zone loads, construction of building occupancy schedule, *EnergyPlus* simulation tools and genetic optimization component. Importing the IDF the *Honeybee* component reconstructing the thermal zone geometry and regenerating in *Grasshopper* environment the opaque and transparent building construction layers. In the second part of the script all the unitary loads value, as for

Table 2. Week average hourly occupancy range in different thermal zones (during week).

	Occupancy range for each thermal zone (n° of people)											
	8 am	9 am	10 am	11 am	12 am	1 pm	2 pm	3 pm	4 pm	5 pm	6 pm	7 pm
Zone 1	0 to 40	40 to 140	80 to 140	80 to 140	40 to 140	40 to 140	80 to 140	80 to 140	80 to 140	0 to 140	0 to 80	0 to 40
Zone 2	20 to 60	20 to 60	20 to 60	20 to 60	20 to 60	20 to 60	20 to 60	20 to 60	20 to 60	20 to 60	20 to 60	20 to 60
Zone 3	0 to 200	0 to 200	0 to 300	100 to 340	300 to 340	100 to 340	200 to 340	300 to 340	200 to 340	0 to 300	0 to 100	0 to 100
Zone 4	0 to 160	0 to 160	80 to 160	80 to 160	0 to 160	80 to 160	80 to 160	80 to 160	0 to 160	0 to 160	0 to 80	0 to 80

instance equipment load per area, lighting density and ventilation per person are defined. Starting from the hourly occupancy range for the different thermal zone defined as function of lecture schedule and preliminary studies as specified in Table 2 a parametric occupancy profile has been created. In detail the annual hourly occupancy pattern has been obtained by applying a recursive series (a weekday series and weekend series) of hourly data for each thermal zone and then duplicated for the number of weeks with the same schedule (spring and fall Italian semester and summer season). Twelve different slider for each thermal zone controlling the people number during daily hours in order to manage individually the occupancy hourly rates have been set-up. The slider increment step is set up equal to twenty people; this step has been defined based on preliminary energy simulation carried out in order to understand the users influence on the energy balance of the thermal zones. A 20 people step represents a good compromise between the *EnergyPlus* sensibility and the number of energy analysis. Using this parametric approach is possible to investigate nimbly different occupancy combination and connect the *Grasshopper* script with genetic optimization tools such as *Octopus*.

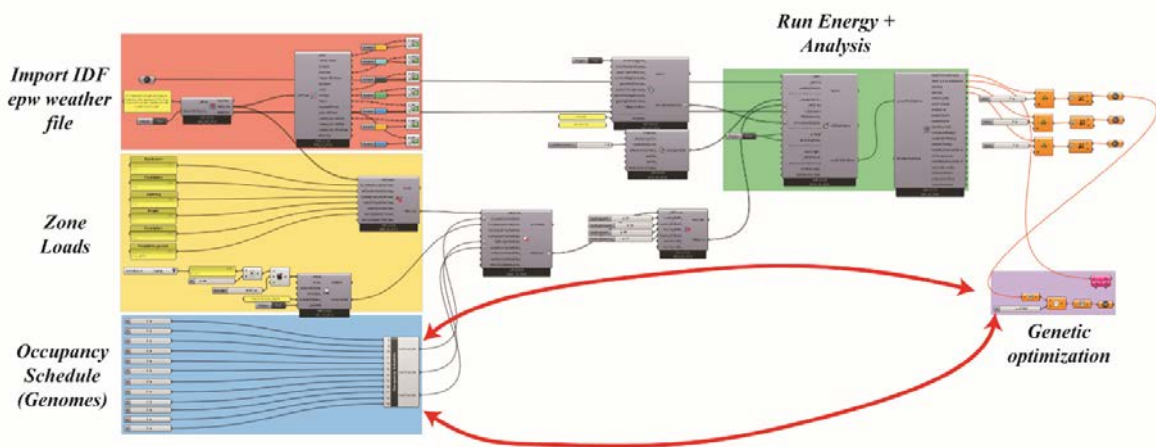

Fig. 4. Grasshopper definition and used optimization workflow.

Once defined the energy model settings and the occupancy profile, using the *Honeybee* components a new IDF file is created and the *EnergyPlus* simulation is started directly in *Grasshopper* environment. In the case study in order to evaluate the influence of the variability of the occupancy, the analyses have been carried out with two different approaches: 1) a parametric one modifying manually the number of people contemporary in the university building and the other 2) using genetic optimization algorithm. Modifying parametrically the occupancy pattern for the different thermal zone it is possible to figure out how the number of people and their spatial and temporal distribution influence heating and cooling consumptions. In particular, various scenarios, for instance medium,

minimum, maximum occupancy and, maintaining constant the total number of people, different occupancy distribution such as Gaussian (max people in the middle part of the day) or inverted Gaussian (max at the beginning and at the end of the day) have been investigated and compared (Section 4). To conclude the parametric analysis has been studied the energy consumption variations in case of new use configuration during the summer season. In particular, the aim was to seek to understand the change occurring increasing the number of people in the period from June to September. Starting from the occupancy profiles used during the year different reduction coefficients equal to 10%, 30%, 60% and with diverse profile in the different thermal zones in order to define the solution providing the higher energy saving (e.g. 60% atrium and classrooms, 10% labs and aula magna) have been applied.

4. Results

4.1. Occupancy parametric analysis

The results show the cases analyzed in the research work. The minimum occupancy level (Case 1) is an extreme condition which is rather infrequent, however it provides the minimum energy consumption as the lower band of the values. The daily changing distribution of the users inside the building produces a variation of about 5-8 kWh/m² year in winter period. In summer period the occupancy value assumed promote a blocked threshold of energy consumption based on medium consumption. The occupancy in the different thermal zones are set up to 60% in the classroom and in the atrium while the aula magna and the PC labs have a 10% of occupancy. The cooling energy consumption usually grows with increasing users' number (Case 3). The energy setting allows to contain the consumption: in the case of medium rate of occupancy (Case 2) the increase of loads is about +2 kWh/m² year (Case 4). On the other hand, if the occupancy reaches the maximum level, the increased cooling need reaches the 27%.

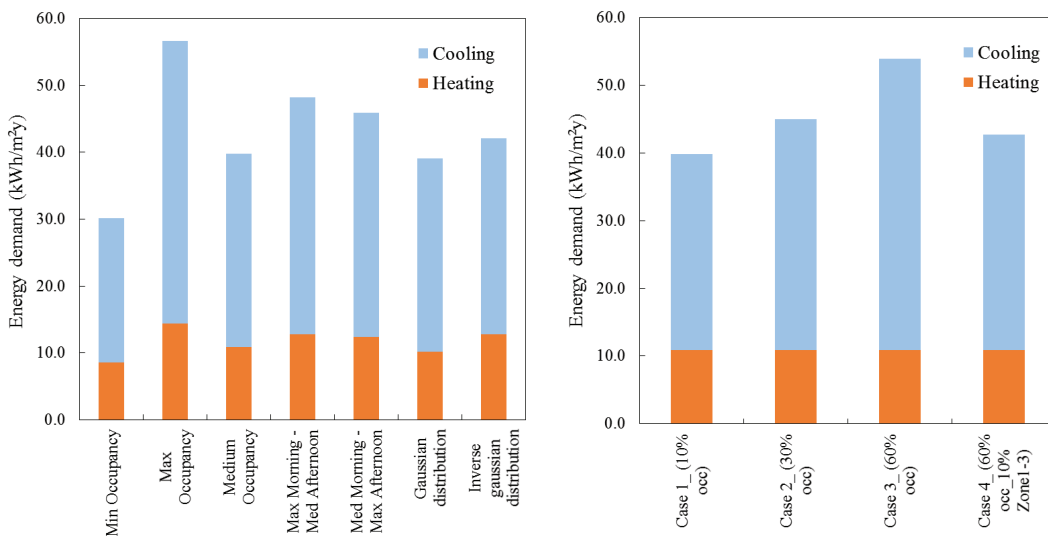

Fig. 5. Energy demand results with different occupancy pattern.

4.2. Genetic optimization

After parametric simulation the feasibility and accuracy of genetic optimization process using the *Octopus* plugin based on Hypervolume Estimation Algorithm [48] has been investigated. Compared to a parametric approach using a genetic algorithms once defined the genomes, in our test case the number of people present each hour inside the building, and the target energy consumption value, will be the component automatically to find the optimized solutions. Fig. 6 shows all the solutions obtained through GA, each point is a mathematical solution of the performance of that particular occupancy profile. Red cubes (Fig. 6) represent the optimized solutions that lie on the

Pareto front [49], these solutions minimize the difference between thermal energy simulation result and the target value (Medium Occupancy).

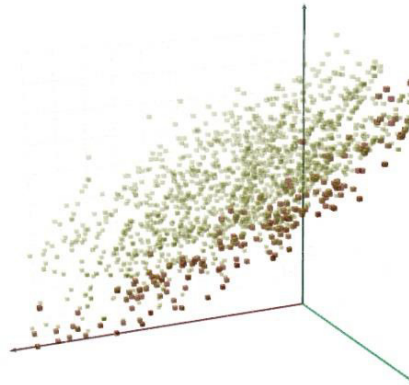

Fig. 6. Pareto front results (red colored cubes represent the optimized solution, minimum gap between objectives and energy consumption).

5. Conclusion

The predicted energy performance based on standard profiles demonstrates evidence of inadequacy to describe the real use of the building. The proposed methodology benefits of VPL to define a structure in which the users' variable can be predicted through advanced modelling techniques. The advantage is to reduce the manual implementation and time-consuming procedures of re-setting of the model to simulate variable behaviors and possible configurations. A more detailed description of the hourly schedule will be implemented to increase accuracy and tune the model based on installed counting-people sensors data. Automation systems and sensing can play an important role in understanding the interaction with occupants by contributing detailed information useful to unveil the dynamic operation patterns. In the first set of simulations, using parametric tool and GA has been possible to identify different occupancy distributions that allow to save energy compared to the actual people range inside the building.

Eventually, the GA seems to be suitable to be adopted to promote a process of optimized convergence of results to energy bills to bridge the performance gap between predicted and actual consumption by a cutting-edge workflow.

References

- [1] B. Wesseling, Y. Deng, et. al., "Sectoral Emission Reduction Potentials and Economic Costs for Climate Change", (SERPEC-CC), Ecofys 2009.
- [2] C. Petersdorff, T. Boermans, J. Harnisch, O. Stobbe, S. Ullrich, S. Wartmann, Cost-Effective Climate Protection in the Building Stock of the EU Building Stock & New EU Member States, commissioned by Eurima, Ecofys 2005.
- [3] T. Boermans, K. Bettgenhäuser, A. Hermelink, S. Schimschar and other Ecofys international staff, Cost optimal building performance requirements Calculation methodology for reporting on national energy performance requirements on the basis of cost optimality within the framework of the EPBD (ENER/C3/2013-414), Commissioned by ecee with financial support from Eurima and the European Climate Foundation (ECF), 19 November 2015, Ecofys 2015 by order of: European Commission.
- [4] T. Boermans, K. Bettgenhäuser, M. Offermann, S. Schimschar, Renovation Tracks for Europe up to 2050: Building renovation in Europe what are the choices?, Ecofys Germany GmbH, 2012.
- [5] European Commission, COM(2011) 112 final, A Roadmap for moving to a competitive low carbon economy in 2050, Communication From The Commission To The European Parliament, The Council, The European Economic And Social Committee And The Committee Of The Regions, Brussels, 8.3.2011.
- [6] Directive 2009/29/EC Of The European Parliament And Of The Council of 23 April 2009 amending Directive 2003/87/EC so as to improve and extend the greenhouse gas emission allowance trading scheme of the Community (Text with EEA relevance), Official Journal of the European Union 5.6.2009, L. 140/63.

- [7] L. C. Tagliabue, M. Manfren, E. De Angelis, Energy Efficiency Assessment Based on Realistic Occupancy Patterns Obtained Through Stochastic Simulation, In *Modelling Behaviour*, pp. 469-478, Springer International Publishing, 2015.
- [8] E. De Angelis, F. Re Cecconi, L.C. Tagliabue, S. Maltese, G. Pansa, A. Torricelli, S. Valagussa, Reliability of energy performance evaluations through different BIM to BEM models, *Convegno Nazionale Annuale ISTeA 2015, Sostenibilità Ambientale e Produzione Edilizia*, Milano, pp. 296-314.
- [9] Directive 2010/31/EU of The European Parliament and of the Council of 19 May 2010 on the energy performance in buildings (recast), *Journal of the European Union L*. 153/13, 18.6.2010.
- [10] R. Burrows, P. Johnson, H. Johnson, Influencing Behaviour by Modelling User Values: Energy Consumption, Second International Workshop on Behavior Change Support Systems (BCSS 2014) in conjunction with the 9th International Conference on Persuasive Technology, Padova, 2014, pp.
- [11] A.C. Menezes, A. Cripps, D. Bouchlaghem, R. Buswell, Predicted vs. actual energy performance of non-domestic buildings: Using post-occupancy evaluation data to reduce the performance gap, *Applied Energy*, 97, 2012, pp.355-364.
- [12] M. Baptista, A. Fang, H. Prendinger, R. Prada, Y. Yamaguchi, Accurate Household Occupant Behavior Modeling Based on Data Mining Techniques, *Proceedings of the Twenty-Eighth AAAI Conference on Artificial Intelligence*, July 27 –31, 2014, Québec City, Palo Alto, pp. 1164-1170.
- [13] V. Fabi, R. Vinther Andersen, S.P. Corgnati, Window opening behaviour: simulations of occupant behaviour in residential buildings using models based on a field survey, *Proceedings of 7th Windsor Conference: The changing context of comfort in an unpredictable world*, Cumberland Lodge, Windsor, 2012.
- [14] C. Malavazos, D. Tzovaras, D. Ioannidis, Activity Based and Behavioural Occupancy Modelling for EE Building Design, *Revista de Edificación*, 41-42, 2013, pp. 109-119.
- [15] W. O'Brien, K. Kapsis, A.K. Athienitis, Manually-operated window shade patterns in office buildings: A critical review, *Building and Environment* 60, 2013, pp. 319-338.
- [16] M. Jahn, M. Eisenhauer, R. Serban, A. Salden, A. Stam, Towards a Context Control Model for Simulation and Optimization of Energy Performance in Buildings, In 9th European conference on product and process modelling (ECPPM 2012), 3rd workshop on eeBDM, eeBIM, Reykjavik.
- [17] L.C. Tagliabue, M. Manfren, A.L.C. Ciribini, E. De Angelis, Probabilistic behavioural modelling in building performance simulation – the Brescia eLUX lab, *Energy and Building*, February 2016, Volume 128, pp. 119–131.
- [18] M. He, T. Lee, S. Taylor, S.K. Firth, K.J. Lomas, Coupling a stochastic occupancy model to EnergyPlus to predict hourly thermal demand of a neighbourhood, 14th Conference of International Building Performance Simulation Association, Hyderabad, 2015, pp. 2101-2018.
- [19] D. Ioannidis, S. Krinidis, G. Stavropoulos, D. Tzovaras, S. Likothanassis, Full-Automated Acquisition System for Occupancy and Energy Measurement Data Extraction, *Symposium on Simulation for Architecture and Urban Design, SimAUD14*, 2014, Article No. 15.
- [20] S.P. Corgnati, E. Fabrizio, M. Filippi, V. Monetti, Reference buildings for cost optimal analysis: Method of definition and application, *Applied Energy*, 102, 2013, pp. 983-993.
- [21] B. Dodson, P. Hammett, R. Klerx, *Probabilistic Design for Optimization and Robustness for Engineers*, Wiley, 2014.
- [22] J. Kurnitski, A. Saari, T. Kalamees, M. Vuolle, J. Niemelä, T. Tark, Cost optimal and nearly zero (nZEB) energy performance calculations for residential buildings with REHVA definition for nZEB national implementation, *Energy and Buildings*, 43 (11) 2011, pp. 3279-3288.
- [23] M. Kapsalaki, V. Leal, M. Santamouris, A methodology for economic efficient design of Net Zero Energy Buildings, *Energy and Buildings*, 55, 2012, pp. 765-778.
- [24] M.M. Sesana, G. Salvalai, Overview on life cycle methodologies and economic feasibility for nZEBs, *Building and Environment*, 67, 2013, pp. 211-216.
- [25] I. Hamilton, P. Steadman, H. Bruhns, *CarbonBuzz – energy data audit*. UCL Energy Institute, July 2011.
- [26] CarbonBuzz website, <http://www.carbonbuzz.org>, [accessed 18.03.16].
- [27] S. Krinidis, G. Stavropoulos, D. Ioannidis, D. Tzovaras, A Robust and Real-Time Multi-Space Occupancy Extraction System Exploiting Privacy-Preserving Sensors, *International Symposium on Communications, Control, and Signal Processing (ISCCSP'14)*, May 21-23, 2014.
- [28] B. Bordass, Energy performance of non-domestic buildings: closing the credibility gap. in *Proceedings of the 2004 Improving Energy Efficiency of Commercial Buildings Conference*, Frankfurt, 2004, pp. 1-10.
- [29] A.L.C. Ciribini, S. Mastrolembo Ventura, M. Paneroni, Implementation of an Interoperable Process to Optimise Design and Construction Phases of a Residential Building: a BIM Pilot Project, *Automation in Construction*, (in press) (2016).
- [30] A. Pavan, B. Daniotti, F. Re Cecconi, S. Maltese, S. Lupica Spagnolo, V. Caffi, M. Chiozzi, D. Pasini, INNOvance: Italian BIM Database for Construction Process Management, 2014 International Conference on Computing in Civil and Building Engineering, Orlando – FL, 23-25 June 2014, pp. 641-648.
- [31] Y.N. Bahar, C. Pere, J. Landrieu, C. Nicolle, A Thermal Simulation Tool for Building and Its Interoperability through the Building Information Modeling (BIM) Platform, *Buildings*, 3, 2013, pp. 380-398.
- [32] T. Laine, K. Bäckström, T. Järvinen, *Energy Analysis, Common BIM Requirements - COBIM series 10*, 2012.
- [33] A.L.C. Ciribini, L.C. Tagliabue, E. De Angelis, S. Mastrolembo Ventura, Modelling for interoperability between building information and energy performance towards management of the building life, *Proceedings of the CIB World Building Congress 2016 Volume IV, Understanding impacts and functioning of different solutions* Edited by Suvi Nenonen, Juha-Matti Junnonen, CIB World Building Congress, 2016, Tampere, pp. 22-33.
- [34] C. Miller, D. Thomas, S. Domingo Irigoyen, C. Hersberger, Z. Zoltán Nagy, D. Rossi, A. Schlueter, BIM - Extracted Energyplus Model Calibration for Retrofit Analysis of A Historically Listed Building in Switzerland, In *Proceedings of SimBuild*, 2014.

- [35] D. Pasini, S. Mastrolembo Ventura, S. Rinaldi, A.L.C. Ciribini, Exploiting Internet of Things and Building Information Modeling Framework for Management of Cognitive Buildings, IEEE International Smart Cities Conference (ISC2), 2016, Trento, pp. 478-483.
- [36] L.C. Tagliabue, M. Manfren, A.L.C. Ciribini, E. De Angelis, Tuning energy performance simulation on behavioural variability with inverse modelling: the case of Smart Campus Building, Sustainable Built Environment (SBE) regional conference Zurich, Expanding Boundaries: Systems Thinking for the Built Environment, 2016, Zurich, pp. 142-147.
- [37] K. Konis, A. Gamas, K. Kensek, Passive performance and building form: An optimization framework for early-stage design support. Solar Energy 125, 2016, pp. 161-179.
- [38] K. Konis, K. Kensek, Leveraging BIM and scripting for passive design parametric analysis. SoCal Gas Commercial Sustainable Development Program Innovative Design for Energy Efficiency Activities (IDEEA) Grant Technical Report, 2015.
- [39] W. Wang, R. Zmeureanu, H. Rivard, Applying multi-objective genetic algorithms in green building design optimization, Building and Environment, Volume 40, Issue 11, 2005, pp. 1512–1525
- [40] A. Schlueter, F. Thesseling, Building information model based energy/exergy performance assessment in early design stages, Automation in Construction, Volume 18, Issue 2, 2009, pp. 153–163.
- [41] K. Negendahl, Building performance simulation in the early design stage: An introduction to integrated dynamic models, Automation in Construction, Volume 54, 2015, pp. 39–53
- [42] S-H. Lin, D.J. Gerber, Designing-in performance: evolutionary energy performance feedback for early stage design, Proceedings of BS2013: 13th Conference of International Building Performance Simulation Association, Chambery, 2013, pp. 386-393.
- [43] McNeel, Food for Rhino. Add-ons for Grasshopper, 2015. <http://www.food4rhino/grasshopper-addons>
- [44] Autodesk, 2015. Autodesk Revit. Building design and construction software <<http://www.autodesk.com/products/revit-family/over-view>>
- [45] E. De Angelis, A.L.C. Ciribini, L.C. Tagliabue, M. Paneroni, The Brescia Smart Campus demonstrator. Renovation toward a zero energy classroom building. Procedia Engineering 118, 2015, pp. 735-743.
- [46] X. Feng, D. Yan, T. Hong, Simulation of occupancy in buildings, Energy and Buildings, 87, 2015, pp. 348-359.
- [47] Ministero dell'Istruzione, dell'Università e della Ricerca MIUR (2013), Linee Guida per le architetture interne delle scuole, 11 Aprile 2013.
- [48] A. Chaszar, P.von Buelow, M. Turrin, Multivariate Interactive Visualization of Data in Generative Design, In Proceedings of the Symposium on Simulation for Architecture & Urban Design, 2016, pp. 223-230.
- [49] Y. Ashour, B. Kolarevic, Optimizing creatively in multi-objective optimization. In Proceedings of the Symposium on Simulation for Architecture & Urban Design, 2015, pp. 128-135.