

Available online at www.sciencedirect.com**ScienceDirect**

Procedia Structural Integrity 7 (2017) 484–491

Structural Integrity

Procediawww.elsevier.com/locate/procedia

3rd International Symposium on Fatigue Design and Material Defects, FDMD 2017, 19-22
September 2017, Lecco, Italy

Experiments on crack propagation and threshold at defects in press-fits of railway axles

S. Foletti^{a,*}, S. Beretta^a, F. Bertozzi^a, M. Carboni^a, S. Cervello^b, D. Regazzi^b

^aPolitecnico di Milano, Dept. Mech. Engng, Via La Masa 1, 20156 Milano, Italy

^bLucchini RS SpA, Via G. Paglia 45, 24065 Lovere (BG), Italy

Abstract

Fatigue strength under fretting fatigue is one of the open problems in the area of fatigue. In the case of railway wheel-axle press-fits, there are no records of recent failures because design rules are today based on making the shape of geometrical transitions the most stressed point. However, it is important to analyze correctly the acceptability of defects and micro-cracks at press-fits.

In this paper, after a preliminary presentation of the results obtained by a new criterion for predicting the non-propagation of cracks under rolling contact fatigue conditions, a new series of experiments on full-scale axle press-fits containing artificial defects is presented and discussed. Results show the modified Dang Van criterion is adequate for describing the development of natural cracks and cracks from artificial defects. The latter, characterized by a depth of 250 – 350 μm , are competitors of fretting cracks naturally developed from surface scars and surface damage.

Copyright © 2017 The Authors. Published by Elsevier B.V.

Peer-review under responsibility of the Scientific Committee of the 3rd International Symposium on Fatigue Design and Material Defects.

Keywords: fretting; defects; threshold; propagation; railway axles

1. Introduction

The investigation of fretting damage and its prolonged consequences in fatigue life assessment is an important issue in railway axle design. Fretting fatigue in axle-wheel press-fits can be described as the repetitive micro sliding of the wheel assembly on press-fit seat due to applied bending and vibrations. Multiple-site surface damage caused by fretting is considered to be the source of crack nucleation, which can become a propagating crack by further application of cyclic loading.

The first aim of the present study is to verify whether the fatigue strength values reported in the relevant European Standard are compatible with the presence of indications usually detected by magnetic particle inspection (MPI) at the end of a fatigue test. This looks to be a significant improvement with respect to the current European Standard EN

* Corresponding author. Tel.: +39-0223998629 ; fax: +39-0223998263.

E-mail address: stefano.foletti@polimi.it

13260 (2009), which requires that “it shall be verified on three specimens that no cracks has appeared after 10^7 cycles of a load creating a surface stress equal to the fatigue limit” (quote from EN 13260 (2009)).

The second aim is to establish a criterion for the acceptability of defects at press-fits in railway axles. In a previous study, see Foletti et al. (2016), the multiaxial high cycle fatigue criterion proposed by Dang Van et al. (1989) and (1993), modified as proposed by Desimone et al. (2006), was applied to the stress distribution, obtained by finite element (FE) analysis. This analysis was conducted along the press-fit contact area for a stress level corresponding to the fatigue strength at 10^7 cycles for press-fits as determined within the Euraxles European Collaborative Project, see Cervello (2016). In detail, the obtained equivalent stress has been treated as the fatigue strength of the material containing defects (the surface damage and scars induced by stick-slip conditions) expressed as a function of defect size through the El Haddad correction, El Haddad et al. (1979). This approach allowed to estimate a maximum allowable depth of defects (for the stress levels corresponding to full-scale fatigue strength at 10^7 cycles) of the order of $250 - 350 \mu\text{m}$.

In this paper, those predictions have been compared with test results on full-scale axles with artificial micro-notches, performed as a part of a collaboration project between PoliMi and Lucchini RS. Experimental tests have then been analysed in terms of fatigue test results and fractographic evidences, which showed a competition of cracks initiating at micronotches and natural fretting cracks.

2. Criterion for fatigue strength/threshold condition of defects under fretting

The proposed procedure is based on a finite element (FE) analysis so as to obtain the stress path under the press fit seat. The stress tensor is used as input in the Dang Van criterion to determine an equivalent stress. The Dang Van criterion can be expressed as, Dang Van et al. (1989) and (1993):

$$\tau_{DV}(t) + \alpha_{DV}\sigma_h(t) \leq \tau_w \quad (1)$$

where α_{DV} is a material constant, τ_w is the fatigue limit in reversed torsion, $\sigma_h(t)$ is the instantaneous hydrostatic component of the stress tensor and $\tau_{DV}(t)$ is the instantaneous value of the Tresca shear stress at mesoscale level. In order to avoid non-conservative predictions in rolling contact fatigue (RCF) problems, Desimone et al. (2006), argued that the failure locus in the region with $\sigma_h(t) < 0$ should be modified into a constant value:

$$\tau_{DV}(t) \leq \tau_w = \frac{\sigma_w}{2} \quad \text{for } \sigma_h < 0 \quad (2)$$

Adopting this failure locus, which is conservative by 10 % with respect to experiments on microdefects under RCF, Foletti et al. (2014), an equivalent stress can be simply expressed for $\sigma_h < 0$ as:

$$\sigma_{eq}^{DV} = 2 \cdot \max(\tau_{DV}(t)) \leq \sigma_w \quad (3)$$

If the relationship between fatigue strength σ_w and defect size is described through the model:

$$\sigma_w = \sigma_{wo} \sqrt{\frac{\sqrt{area_o}}{\sqrt{area} + \sqrt{area_o}}} \quad (4)$$

where \sqrt{area} is the defect size expressed by Murakami's parameter (see Murakami (2002)) and $\sqrt{area_o}$ is the El-Haddad's parameter expressed in the same way, the critical defect size for a given multiaxial stress σ_{eq}^{DV} can then be determined:

$$\sqrt{area_{crit}} : \sigma_{eq}^{DV} = \sigma_w \quad (5)$$

Considering a shallow 2D surface crack with a length c , the parameter can be calculated as $\sqrt{area} = \sqrt{10} \cdot c$ (see Murakami (2002)). It is therefore simple to find a critical defect size (or depth by knowing the orientation angle, see Fig. 1a) for a given multiaxial stress state (provided that $\sigma_h < 0$). The orientation of the critical defect size can be obtained by considering the critical plane version of the Dang Van criterion. Considering a material plane defined by its unit normal vector \underline{n} the Dang Van shear stress can be defined as:

$$\tau_{DV}(\phi, \theta, t) = \|\underline{\tau}(\phi, \theta, t) - \underline{\tau}_m(\phi, \theta)\| \quad (6)$$

where ϕ and θ are the spherical angles used to express the unit normal vector \underline{n} in a O_{xyz} frame. $\underline{\tau}(\phi, \theta, t)$ is the shear stress vector acting on the material plane under consideration, $\underline{\tau}_m(\phi, \theta)$ is the mean shear stress vector and the bracket symbol ($\|\ \|\|$) represents the length (measure) of the enclosed vector. Computing the mean shear stress on every plane passing through a point, the determination of the critical plane, according to Dang Van criterion, requires the solution of the double maximization problem:

$$\phi^*, \theta^* : \max_{\phi, \theta} \left[\max_t \|\underline{\tau}(\phi, \theta, t) - \underline{\tau}_m(\phi, \theta)\| \right] \tag{7}$$

2.1. Application to fretting fatigue strength of full-scale axles

The proposed method was applied to the experimental results of fretting fatigue tests conducted on full scale EA4T railway axles with F4 geometry on a two points rotating bending resonant bench (Minden type test rig), see Foletti et al. (2016). Part of the fatigue tests was carried out in the frame of the Euraxles European Collaborative Project (see also Cervello (2016)) and the remaining ones in the frame of a private research contract between Lucchini RS SpA and Politecnico di Milano, Department of Mechanical Engineering.

The F4 geometry was designed to evaluate the fatigue strength at the press-fit. The selected diameter ratio $D/d = 1.12$ is the minimum accepted value in the design of axles that may be reached in service due to some consecutive seat re-profiling made in maintenance, see EN 13103 (2009) and EN 13104 (2009).

In order to obtain the stress path in the critical regions of the shaft, several FE analyses were carried out at different load levels simulating the failure (nominal bending stress $\sigma_{nom} = 132$ MPa) and the run-out ($\sigma_{nom} = 120$ MPa) conditions as experimentally obtained. The details about the finite element model can be found in Foletti et al. (2016).

In Figure 1b, results showing the non-propagating crack size for F4 axle under the two different loading conditions, failure and run-out, are presented. Due to the numerical stress singularity at the seat edge where the transition to the axle body starts, the proposed method can be applied starting from 2-3 mm away from the transition edge. As shown in Figure 1b, the predicted region susceptible to crack propagation is found to be located at a distance of 4-10 mm away from transition edge. When a nominal stress of 132 MPa (dashed line corresponding to a failure condition in Figure 1b) is applied, allowable crack size is predicted to be $c = 450 \mu\text{m}$ in length. This limitation increases to a level of $c = 540 \mu\text{m}$ for an applied stress $\sigma_{nom} = 120$ MPa, which is the loading condition for run-out axles. The critical plane orientation θ , presented in Figure 1b and independently from the applied nominal stress, was estimated to be in the range $20 - 25^\circ$.

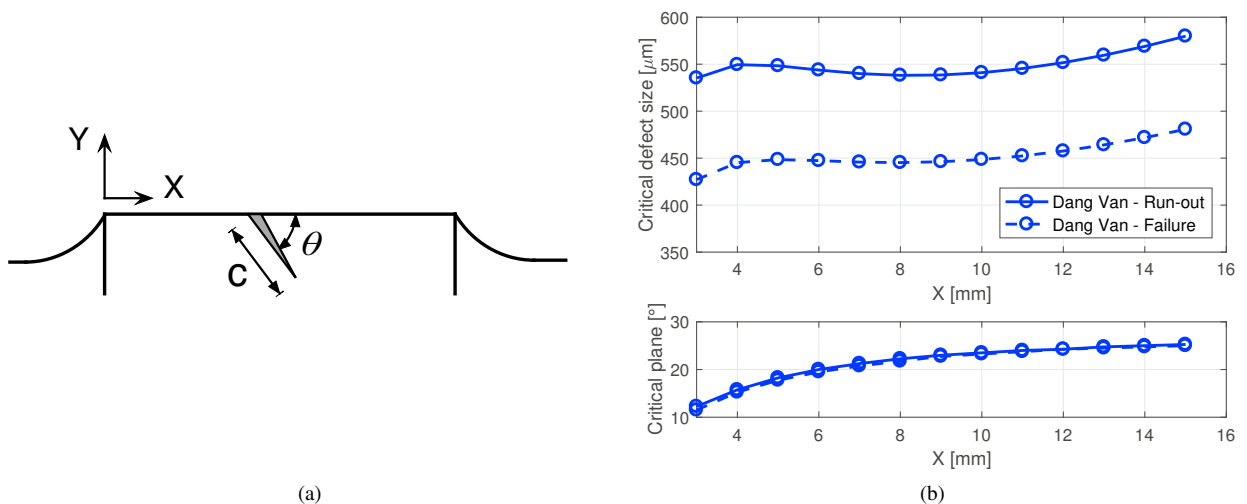

Fig. 1. Prediction of allowable defect sizes under fretting fatigue by a modified Dang Van criterion: a) problem statement; b) predictions by Foletti et al. (2016).

3. Full scale experiments with micronotches

In order to verify the prediction of maximum acceptable defects at press-fits, a series of experimental tests were carried out. In details, the axles were press-fitted with a hub shaped as a real wheel hub and made of ER7T steel and they contained a series of four circumferential micronotches obtained by Electrical Discharge Machining (EDM). Fatigue tests were carried out under a three point rotating bending bench (Minden type test rig) at PoliMi on EA4T full-scale axles with a diameter of the press-fit seat equal to $D = 180 \text{ mm}$ and a ratio $D/d = 1.12$, see Figure 2.

Micronotches were located at the distance $x = 10 \text{ mm}$ from the transition edge, close to the minimum allowable crack size predicted by the model, see Figure 1b. At this distance, the maximum allowable defect depth predicted by the criterion for the axle's geometry under investigation is shown in Figure 3a. The fatigue strength is decreasing with respect to the one of a smooth axle only if a defect with a depth greater than $250 \mu\text{m}$ is present.

In order to check the predictive capability of the criterion the first four axles were prepared with micronotches machined in vertical direction with a depth of $350 \mu\text{m}$, a value corresponding to a reduction of the fatigue strength. Other two tests were carried out by Lucchini RS on axles with EDM micronotches (similar orientation and location) with a depth of $250 \mu\text{m}$ tested in similar conditions.

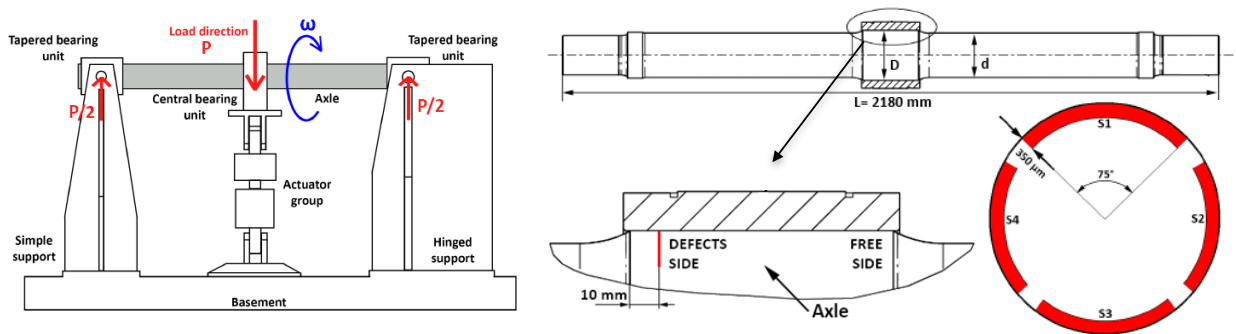

Fig. 2. Test rig and axle geometry containing circumferential micronotches.

During the tests, axles were periodically inspected by Phased Array Ultrasonic Testing (UT) adopting a Flat-Bottomed Hole (FBH) calibration of 1 mm. After they reached a run-out condition at a first stress level, the stress level was increased and the test was continued until failure or survival to $20 \cdot 10^6$ cycles. At this final stage, all the press-fits were dismantled by carefully milling the hubs in longitudinal directions. Axle press-fit seats were, then, examined by MPI (to verify if there were indications compatible with EN13260) and eventually sectioned and examined under scanning electron microscope (SEM) and optical microscope.

Table 1. Details of the full-scale tests with artificial defects.

Test number	defect depth	stress σ_{nom} [MPa]	Result	NDT indications	crack location
# 1	$350 \mu\text{m}$	108	run-out at 10^7 cycles	no UT indications	
		150	failed at $1.9 \cdot 10^6$ cycles	UT indications after $1.3 \cdot 10^6$ cycles	micronotches and press-fit region
# 2	$350 \mu\text{m}$	108	run-out at 10^7 cycles	no UT indications	
		120	failed at $9 \cdot 10^6$ cycles	UT indications after $9 \cdot 10^6$ cycles	micronotches and press-fit region
# 3	$350 \mu\text{m}$	108	run-out at 10^7 cycles	no UT indications	
		120	failed at $24 \cdot 10^6$ cycles	UT indications after $24 \cdot 10^6$ cycles	micronotches and press-fit region
# 4	$350 \mu\text{m}$	108	run-out at 10^7 cycles	no UT indications	
		135	failed at $6.5 \cdot 10^6$ cycles	UT indications after $4 \cdot 10^6$ cycles	micronotches and press-fit region
# 5	$250 \mu\text{m}$	120	run-out at $20 \cdot 10^6$ cycles	MPI indications	press-fit region
# 6	$250 \mu\text{m}$	120	run-out at $20 \cdot 10^6$ cycles	MPI indications	micronotches and press-fit region
		135	run-out at $20 \cdot 10^6$ cycles	MPI indications	micronotches and press-fit region

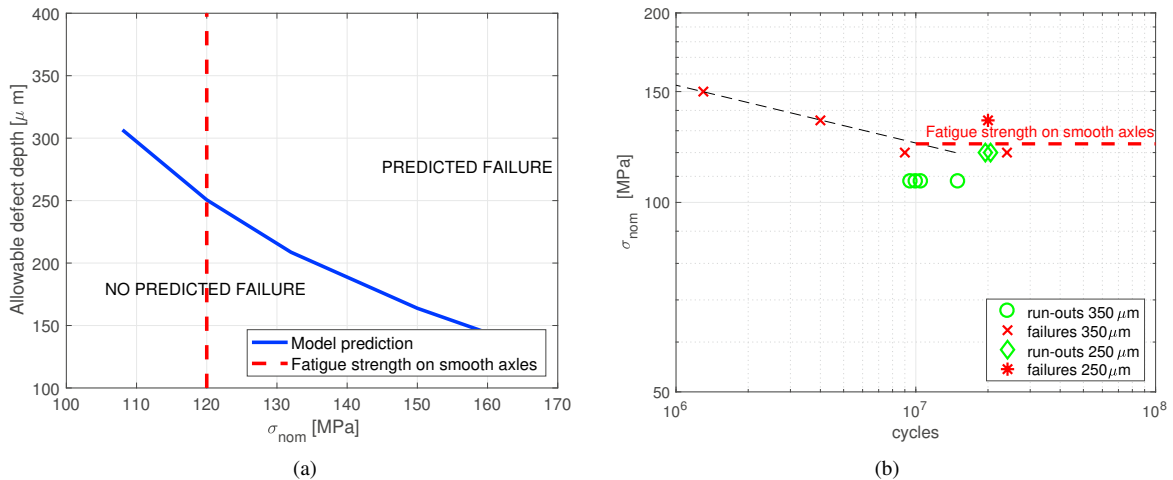

Fig. 3. a) Prediction of the allowable defect depth under fretting; b) S-N diagram of the fretting tests on full-scale axles containing circumferential micronotches.

3.1. Test results

Experimental results are reported in details in Table 1 and Figure 3b in terms of a prospective S-N diagram for axle press-fits. For a defect depth of 350 μm, the full-scale fatigue strength is slightly lower than the one of smooth axles, while the presence of a defect with a depth of 250 μm seems not to affect the fatigue strength.

The fractographies are reported in Figure 4. Considering Axle #1, it presented no UT indications at the end of the first load step (110 MPa), while it failed rapidly, as expected, during the second one (150 MPa). Final failure originated at micronotches with a maximum crack depth of 25 mm. Multiple cracks originated in the free side at a distance from the edge of the seat ranging from 5 to 15 mm, see Figure 4a and 4b.

In the case of Axle #2, the first load step (110 MPa) didn't show, again, any UT indications, while, during the second one (120 MPa), some were detected after about $9 \cdot 10^6$ cycles. The test was, then, interrupted in order to investigate the indications without reaching the final failure of the axle. The indications were confirmed by MPI and the relevant regions sectioned and lapped. Figure 4c and 4d show that fretting fatigue cracks originated at both micronotches and the press-fit region. Axle #3 was tested repeating the same load program used for Axle #2, getting very similar results (Fig. 4e).

Finally, Axle #4 was first tested at 110 MPa without showing any UT indications and, then, at 135 MPa, which it failed at (Fig. 4f). Failure originated at micronotches with a final crack depth of 24 mm.

Axles #5, with a defect depth of 250 μm, tested at 120 MPa (which is the upper limit of survival in the Euraxles tests at 10⁷ cycles) showed significant cracks at the press-fit region after $20 \cdot 10^6$ cycles and no visual indications of cracks originating from artificial micronotches. Naturally propagating cracks seem, then, to be competitive with the artificial defects with a depth of 250 μm. Regarding Axle #6 the analysis of cracks is still in progress.



(a) Axle #1. Final failure at a micronotch. Maximum crack depth: 25mm

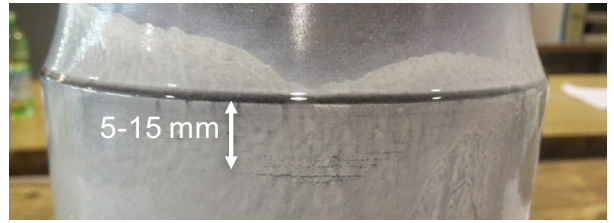

(b) Axle #1. Multiple cracks at the press-fit region

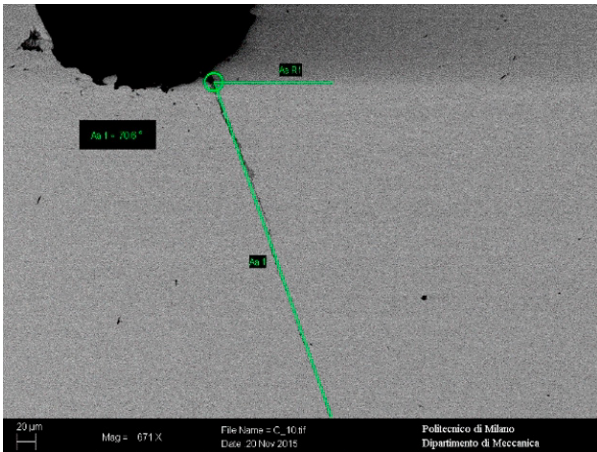

(c) Axle #2. Crack at a micronotch

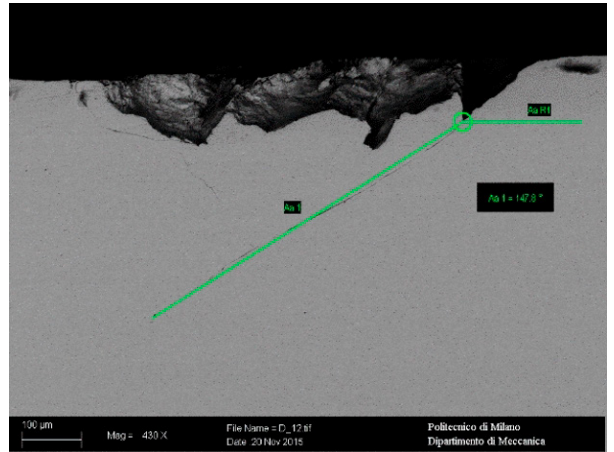

(d) Axle #2. Multiple cracks at the press-fit region

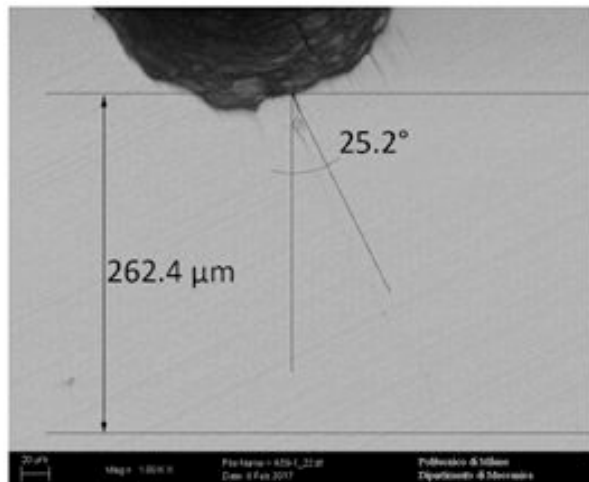

(e) Axle #3. Crack at a micronotch



(f) Axle #4: Final failure at a micronotch. Maximum crack depth: 24mm

Fig. 4. Fractographies and development of fretting fatigue cracks.

3.2. Comparison with predictions

The summary of the experimental results is shown in Figure 5 together with the comparison with the predicted failure locus. The results show that the proposed model based on the Dang van criterion is slightly conservative in predicting the fatigue strength in presence of a defect with a depth of $350\mu\text{m}$.

On the other hand, as predicted by the model, an artificial defect with a depth of $250\mu\text{m}$ is competitive with naturally propagating cracks originated from surface scars and surface damage, leading to an unchanged fatigue strength.

Nevertheless, the failure condition is always well predicted by the model for both defect sizes.

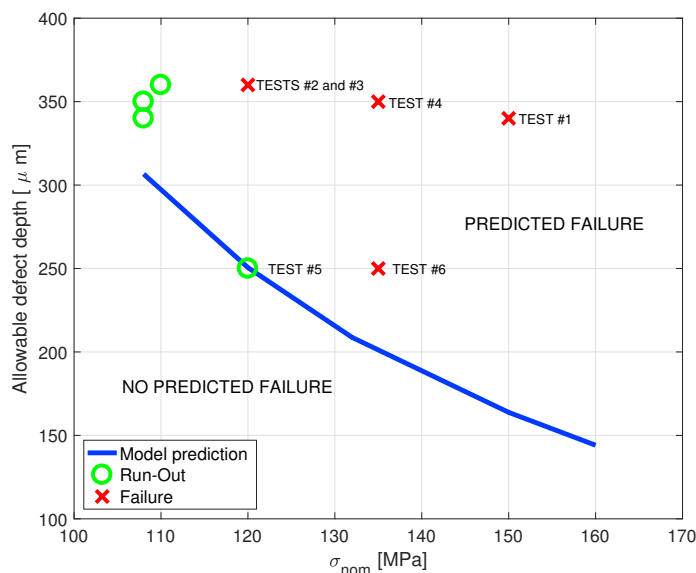

Fig. 5. Comparison between experimental results and the failure locus according to the Dang Van modified criterion.

4. Concluding remarks

A model based on Dang Van criterion together with El Haddad correction has been developed in order to study defects acceptability at press-fits. This approach has been verified by a series of full-scale tests on press-fits of railway axles. Tests have been carried out at the stress levels of the full-scale fatigue strength for EA4T steel, as determined by the Euraxles European Collaborative Project, adopting full-scale tests pieces with EDM circumferential defects.

A defect with a depth of $250\mu\text{m}$ is compatible with the full-scale fretting fatigue strength for EA4T steel, as determined by the Euraxles European Collaborative Project. Naturally propagating cracks are competitive with the artificial defects. The axles tested at 120 MPa showed significant crack development from both surface fretting damage and artificial defects of 250 and $350\mu\text{m}$. This confirms the prediction this is the range for *critical defect size* compatible with the fatigue strength for press-fits. A defect with a depth of $350\mu\text{m}$ slightly reduced the full-scale fretting fatigue strength.

The modified Dang Van model correctly estimates the fretting fatigue limit in presence of a defect.

Acknowledgements

Part of the fatigue tests was carried out in the frame of the Euraxles European Collaborative Project, while the remaining part of the full scale tests and the analysis were carried out within a private research contract between Lucchini RS SpA and Politecnico di Milano, Department of Mechanical Engineering, aimed at developing tools for the structural integrity assessment of railway axles.

References

- Cervello, S., 2016. Fatigue properties of railway axles: new results of full-scale specimens from EURAXLES project. *Int J Fatigue* 86:2-12.
- Dang Van, K., Griveau, B., Message, O., 1989. In: Brown MW, Miller KJ, editors. EGF 3. London: Mechanical Engineering Publications; pp. 479-96.
- Dang Van, K., 1993. In: McDowell DL, Ellis R. (eds.), *Advances in multiaxial fatigue*, ASTM STP 1191; pp. 120-30.
- Desimone, H., Bernasconi, A., Beretta, S., 2006. On the application of Dang Van criterion to rolling contact fatigue. *Wear* 260(4-5):567-72.
- El Haddad, M., Smith, K., Topper, T., 1979. Fatigue crack propagation of short cracks. *J Eng Mater Technol* 101(1):42-6.
- EN 13260:2009+A1:2010. Railway applications - wheelsets and bogies - wheelsets - product requirements.
- EN 13103:2009+A2:2012. Railway applications - wheelsets and bogies - non powered axles - design method.
- EN 13104:2009+A2:2012. Railway applications - wheelsets and bogies - powered axles - design method.
- Foletti, S., Beretta, S., Gurer, G., 2016. Defect acceptability under full-scale fretting fatigue tests for railway axles. *Int J Fatigue* 86:34-43.
- Foletti, S., Beretta, S., Tarantini, M.G., 2014. Multiaxial fatigue criteria versus experiments for small crack under rolling contact fatigue. *Int J Fatigue* 58:181-192.
- Murakami, Y., 2002. *Metal fatigue: effects of small defects and nonmetallic inclusions*: effects of small defects and nonmetallic inclusions. Elsevier.