



## EcoDesign 2.0 - Quantitative EcoDesign within Drives and Automation Technologies

**Auer, Johannes**

*Publication date:*  
2017

*Document Version*  
Publisher's PDF, also known as Version of record

[Link back to DTU Orbit](#)

*Citation (APA):*  
Auer, J. (2017). EcoDesign 2.0 - Quantitative EcoDesign within Drives and Automation Technologies. DTU Management.

---

### General rights

Copyright and moral rights for the publications made accessible in the public portal are retained by the authors and/or other copyright owners and it is a condition of accessing publications that users recognise and abide by the legal requirements associated with these rights.

- Users may download and print one copy of any publication from the public portal for the purpose of private study or research.
- You may not further distribute the material or use it for any profit-making activity or commercial gain
- You may freely distribute the URL identifying the publication in the public portal

If you believe that this document breaches copyright please contact us providing details, and we will remove access to the work immediately and investigate your claim.

## EcoDesign 2.0

### Quantitative Ecodesign within Drives and Automation Technologies



Johannes Auer, May 2017





# **Ecodesign 2.0 –** Quantitative Ecodesign within Drives and Automation Technologies

Johannes Auer

PhD Thesis | May 2017

Siemens AG  
Process Industries & Drives Division  
Nuremberg, Germany

---

Division for Quantitative Sustainability Assessment  
Department of Management Engineering  
Technical University of Denmark

*“Some people feel the rain. Others just get wet.”*

Bob Marley

# PREFACE

This PhD thesis presents the outcome of the PhD research project “EcoDesign 2.0: Quantitative Ecodesign within Drives & Automation Technologies.” The project was carried out at the Division for Quantitative Sustainability Assessment (QSA) of the Department of Management Engineering at the Technical University of Denmark (DTU) and at the Siemens AG, Process Industries & Drives Division (PD), in Nuremberg, Germany. The project was supervised by Associate Professor Niki Bey (main supervisor), Adjunct Professor Dieter Wegner and Professor Michael Zwicky Hauschild.

The PhD project was carried out from June 2014 to May 2017, working at Siemens AG as Coordinator for Product-related Environmental Protection (PrEP) and ecodesign governance owner for the PD Division. Therefore various internal and external works were conducted during the project, associated with the thesis, as for instance convening of and participating in standardisation working groups dealing with eco-design, environmentally conscious design process, life cycle assessment and material efficiency, as well as developing and supporting the development of an appropriate set-up and methods for the company’s eco-design approach.

The backbone of this thesis are 3 scientific articles, of which one has been published, one is accepted and one is submitted at the time of writing and 2 conference contributions, also peer-reviewed, presented at the cited conference and available in the proceedings. These are included as appendices and will be referred to by the numbers given below:

JP-I: Auer J., Bey N. & Schäfer, J.M. 2017, 'Combined Life Cycle Assessment and Life Cycle Costing in the Eco-Care-Matrix: A case study on the performance of a modernized manufacturing system for glass containers' Journal of Cleaner Production, vol 141, pp. 99-109. DOI: 10.1016/j.jclepro.2016.08.096

JP-II: Auer J., Meincke A. 2017, 'Comparative Life Cycle Assessment of electric motors with different efficiency classes: A deep dive into the trade-offs between the life cycle stages in Ecodesign context' The International Journal of Life Cycle Assessment, tbp. Manuscript submitted 01/2017: JLCA-D-17-00006R1

JP-III: Auer J., Bey N. & Weis B. 2017 'New innovative standard series for drive systems: Introducing and testing the extended product approach for tackling energy efficiency in application view', tbp. Manuscript submitted 05/2017: SMEJMS-D-17-00237

C-I: Auer J., Zintl A., Berninger B., Bey N. 2014 'Comparison of two different approaches for a simplified life cycle assessment of electronics', Session 3.1.: Sustainability and Environmental Assessment, lecture 3.1.2., CARE Innovation 2014 Conference, Vienna.

C-II: Auer J., Weis B.: 'New standard on Ecodesign for power drive systems, motor starters, power electronics & their driven applications: Introducing the Extended Product Approach and product Category Rules for Motor Systems', Session 3.1.: Impacts of legislation, lecture 2.14.1., CARE Innovation 2014 Conference, Vienna.

Furthermore, supervised and commissioned master and bachelor thesis, conducted in Siemens AG in collaboration with German universities and DTU, respectively, provided results presented in the following. The English abstracts of these thesis (most of them are in German language) are also included in the annex and referred to by the references provided in **Table 1**:

Table 1: Referenced student projects (master- or bachelor theses). Abstracts are included in the annex.

<i>Reference</i>	<i>Author</i>	<i>Title</i>	<i>Date</i>
R-I	Stefanie Claudia Kotulla	Parameterized LCA modeling of converters in GaBi DfX	09/11
R-II	Steffen Lömmer	Elaboration of a parameterized LCA model of the 1FK7 servo motor product family according to ISO 14040 with the software GaBi 4 DfX	11/12
R-III	Philipp Knauf	Elaboration of a parameterized Life Cycle Assessment of electric motors of the product family 1PH8 with evaluation of end-of-life scenarios	02/14
R-IV	Paulina Casas Muñoz; Larisa Xanthopoulou	Life Cycle Assessment of Vertical Mills for Siemens Environmental Product Management	07/14
R-V	Jeanette Ullmann	Life Cycle Assessment of products for industrial communication	08/14
R-VI	Günther Pröls	Partial automation of Life Cycle Assessments in GaBi6	02/15
R-VII	Cecilie Overgaard Fjordmand	Simplification of Life Cycle Assessment through Black Box Modelling	08/16



Additionally the following reports elaborated in context to conducted courses are referenced and therefore attached to this thesis.

[COSI 2015] Auer J.: Capstone Project Report – Analysis of the efficiency of the Ecodesign directive in regards to the political goal on climate change. CBS/KU/DTU course 42349/42350 (master level) – Sustainability Challenges & Systems Thinking II: Specific Systems and capstone project. 2015.

[LCM 2016] Auer J.: Project Report – Life cycle management at Siemens Pro-cess Industries and Drives (PD Division). DTU course 42377 (master level) – Life Cycle Management in Industry. 2016.

# ACKNOWLEDGEMENTS

So, three years later and it's done now? Time flew retrospectively, especially in the last year of the study. And yes, connecting back into research and teaching, felt like a breath of fresh air. And yes, I also must admit I still learned a lot, even though being a (self-claimed) professional in the field of ecodesign in the last 8 years of my industrial career.

In this context, first and foremost I have to thank my extended family for having my back while conducting this project, besides my “other duties”, pursuing to finalise it successfully. Unforeseeable, but luckily, it's been challenging with the birth of the twins in 2015 and the whole cause-effect chain resulting from this. Sarina, Dylan, Zoe, Jamie, my parents and parents-in-law, as well as “Uncle Franz” – big up, as we say, and one love to all of you, you know who you are.

Next, I want to thank my manager at Siemens AG, Walter Niedermayer, who also supported me (and the project) in perusing this goal. Then I have to thank the other colleagues at the department for being supportive in these last three years, especially Wolfgang Fochtner, Dirk Schlitt and all the students that have been a part of the journey, as well as the colleagues around the job family, Stefanie Fischer Fernandez and Olga Heim, Andreas Weber, Eva-Maria Wagner, Peter Zwanziger, Benno Weis & Karl Hiereth. Further Katrin Melzer, Falko Parthey, Jens Holst, Frank Walachowicz and Sabrina Paeglow for being inspiring, supportive and good consultants – in one way or the other – in ecodesign and life cycle assessment from different units of the Siemens universe.

Then this would not have worked without, in particular, the main supervisor Niki Bey. Further, I would like to thank the co-supervisors Michael Zwicky Hauschild and Dieter Wegener also for guidance in and around the project. Thanks also to the other people at the QSA Division at DTU, especially my fellows (Jan) Markus, Teunis, Andrea, Benjamin, Monia and Raphaele, as well as Christine, Alexis, Nuno, Stig and Morten for sharing thoughts, insights and fun.

# SUMMARY

The PhD project has its research background mainly in the fields of product development & design, manufacturing systems and quantitative sustainability assessment, incl. environmental Life Cycle Assessment (LCA). Related organizational and management research is also drawn upon as well as systems engineering approaches. Research focus lies in areas where these fields overlap and complement each other in the development process of given applications, in particular the development and implementation of Drives and Automation Technologies.

The evaluation of the research background, based on research projects [Thomas 2012; Meincke 2012; Röttjes 2012; Gama & Herrmann, 2013], scientific publications, e.g. [McAloone & Bey 2009; Wimmer et al., 2014] and practical experience (e.g. development of international standards, implementing eco-design at Siemens) lead to the formulation of the corresponding challenges and a problem statement, which is followed up by the research objective of the development of an “Ecodesign 2.0” (ECD2.0) approach and the definition of key requirements for the approach in terms of underlying methods and supportive means.

In the execution of the project, the research background and currently implemented state-of-the-art of eco-design of drives and automation technologies in discrete and process industries was evaluated, putting it in context to the processes and portfolio of the Siemens AG, Process Industries & Drives Division (PD), as well as current sustainability challenges. This led to the formulation of the following research challenges:

- Lack of methodological support to create insight regarding system-context-depending eco-performance; i.e. lack of generic understanding of environmental performance of the stand-alone product vs. the environmental performance of the entire solution/application which the product is part of;
- During design, lack of guidance towards a structured balancing or combination of early-stage qualitative approaches (e.g. for idea/concept evaluation) and later-stage quantitative approaches (e.g. for product documentation);
- Lack of systematic approaches to design the above in a comprehensive and yet feasible way, applicable in industrial settings – and with regard to special conditions opposed by long application life times and high customer investments that may be involved.

This then led to the working hypothesis, that instead of dealing with single products, eco-design of industrial automation and drive technologies has to address the key issue of the solution's usage stage in terms of system design corresponding to the application context, where several products work in conjunction with each other. Further, in response to the above challenges, the overall objective of the PhD project was set to create supportive means (tools, methods, models, etc.) which stimulate design of non-sub-optimised solutions through focussing on improving automation and drive technologies in an application context. Based upon this, the research was defined by evaluating and

choosing appropriate underlying methods and reference applications for conducting the corresponding case studies.

Appropriate methods were found by discussions and literature reviews, for conducting the case studies to elaborate on the hypothesis by applying LCA and Life Cycle Costing (LCC) and displaying the results in an eco-efficiency tool, the Siemens Eco-Care-Matrix (ECM). The hypothesis was then proven by investigating implemented full-scale reference applications considering environmental and economic facts evaluated over the whole product/application life cycle, which can be found in chapters 6 (reference applications), 7 and 8 (case study results).

Further the ECD2.0 approach was outlined, based on the eco-efficiency tool ECM, supported by LCA and LCC as underlying methods, utilizing the newly developed 'Extended Product Approach' (EPA) for describing 'functional unit', as interface definition between the application and the supporting system.

Finally, the results are discussed and concluded upon, by picking up the topic of necessary enablers, such as a simplified LCA approach and robust characterisation methods, as well as application examples in sales and portfolio management context.

# DANSK SAMMENFATNING

Ph.d.-projektet har sit forskningsgrundlag primært inden for produktudvikling og design, produktionssystemer og kvantitativ bæredygtighedsvurdering, inkl. miljømæssig livscyklusvurdering. Relateret organisations- og ledelsesforskning er også inddraget, såvel som systemtekniske tilgange. Forskningsfokus ligger i områderne, hvor disse felter overlapper med hinanden og supplerer hinanden i udviklingsprocessen af givne applikationer, især udvikling og implementering af Drives and Automation Technologies.

Evalueringen af disse to felter, baserer sig på forskningsprojekter [Thomas 2012; Meincke 2012; Röttjes 2012; Gama & Herrmann, 2013], videnskabelige publikationer, f.eks. [McAloone & Bey 2009; Wimmer et al., 2014] og praktisk erfaring, fx udvikling af internationale standarder, gennemførelse af miljørigtig produktudvikling (dvs. ecodesign) i Siemens. Dette fører til formulering af de tilsvarende udfordringer og en problemstilling, der følges op af beskrivelsen af forskningsformålet med udviklingen af en "Ecodesign 2.0"-tilgang (ECD2.0) og definitionen af centrale krav til denne tilgang med hensyn til underliggende metoder og understøttende midler.

Ved udførelsen af projektet blev forskningsgrundlaget og den nuværende implementerede state-of-the-art af ecodesign af drives- og automatiseringsteknologier i diskret- og procesindustrien evalueret og sat i sammenhæng med processerne og porteføljen af Siemens AG, Process Industries & Drives Division (PD), samt med aktuelle

bæredygtighedsudfordringer. Dette er behandlet i kapitlerne 1, 2 og 3 og førte til følgende forskningsudfordringer (kapitel 4):

- Mangel på metodisk støtte til at skabe indsigt i system-kontekstafhængig miljøpræstation. Dvs. mangel på en generisk forståelse af miljøprofilen af det enkelte produkt kontra miljøprofilen af hele løsningen/applikationen, som det pågældende produkt er en del af
- I forhold til design- & udviklingsprocessen mangler der rettesnor ift. en struktureret afvejning eller kombination af kvalitative metoder i de tidlige faser (fx under idé- og konceptevaluering) og de senere fasers kvantitative tilgange (fx ift. produktdokumentation)
- Manglende systematiske metoder til at designe ovennævnte på en overordnet og alligevel anvendelig måde, der er praktikabel i industrielle omgivelser – og med hensyn til særlige forhold såsom lang levetid og store kundeinvesteringer, der kan være involveret

Dette førte derefter til arbejdshypotesen, at i stedet for at beskæftige sig med enkeltprodukter skal ecodesign af industriel drives- og automations-teknologi omhandle det centrale problem, der ligger i applikationens brugsfase – og gør dette i form af systemdesign, der tilgodeser applikationskonteksten, siden det typisk er flere enkeltprodukter, der arbejder sammen med hinanden i applikationen. Som svar på ovenstående udfordringer blev det overordnede mål for ph.d.-projektet sat til at være: Skabelse af støttemidler (værktøjer, metoder, modeller osv.), som stimulerer design af ikke-suboptimerede løsninger ved at fokusere på at forbedre drives- og automations-teknologier i en applikationskontekst. På baggrund heraf blev

xiv



forskningen defineret ved at vælge passende underliggende metoder og reference-applikationer til gennemførelse af tilsvarende casestudier.

Passende metoder blev fundet gennem diskussioner og litteratursøgning omkring casestudierne for at uddybe hypotesen ved at anvende LCA og LCC og vise resultaterne i et eco-efficiency-værktøj, den såkaldte Siemens' Eco-Care-Matrix (ECM).

Denne hypotese blev derefter bevist ved at undersøge implementerede fuldskala reference-applikationer mhp. miljømæssige og økonomiske forhold, som blev evalueret over hele produktets/applikationens livscyklus. Dette er beskrevet i kapitlerne 6 (reference-applikationer), 7 og 8 (casestudie-resultater).

Endvidere blev den udviklede ECD2.0-tilgang beskrevet ift. eco-efficiency-værktøjet ECM, støttet af LCA og LCC som underliggende metoder, ved anvendelse af den nyudviklede europæiske "Extended Product Approach" (EPA) til beskrivelse af "funktionel enhed" som grænsefladedefinition mellem applikationen og dens respektive støttesystem.

Endelig drøftes og konkluderes på resultaterne ved at belyse emnet "nødvendige enablers", såsom for eksempel en forenklet LCA-tilgang og robuste karakteriseringsmetoder samt applikationseksempler i salgs- og porteføljestyringen.



# Table of contents

<b>1</b>	<b>INTRODUCTION</b>	<b>1</b>
1.1	MOTIVATION AND BACKGROUND OF THE PHD THESIS	1
1.2	GENERAL RESEARCH BACKGROUND: SUSTAINABILITY CHALLENGES & SYSTEMS THINKING	5
<b>2</b>	<b>BACKGROUND OF RESEARCH</b>	<b>11</b>
2.1	SIEMENS AG	11
2.1.1	<i>General</i>	11
2.1.2	<i>Process Industries &amp; Drives (PD) Divisions' businesses</i>	12
2.2	SUSTAINABILITY @ SIEMENS AG: PD DIVISION	15
2.3	SUSTAINABILITY ASPECTS IN CONTEXT TO SIEMENS PD OPERATIONS	18
2.3.1	<i>Organizational background</i>	18
2.3.2	<i>PD approach</i>	19
2.3.3	<i>Environmentally conscious design approach</i>	20
2.4	INDUSTRIAL AUTOMATION AND DRIVE SYSTEMS	22
2.4.1	<i>General</i>	22
2.4.2	<i>Discrete versus Process Industries</i>	23
2.4.3	<i>Integrated Drive System (IDS)</i>	27
2.5	LITERATURE REVIEW: ECO-DESIGN APPROACHES	29
2.5.1	<i>Methodology</i>	29
2.5.2	<i>General Overview</i>	31
2.5.3	<i>Historical Development of Ecodesign.</i>	33
2.5.4	<i>Key Ecodesign Approaches and supporting Methods</i>	42
2.5.5	<i>Summary: Ecodesign Methods in context to ECD 2.0</i>	47
<b>3</b>	<b>CURRENT STATE-OF-THE-ART OF ECODESIGN IN INDUSTRIAL AUTOMATION AND DRIVE TECHNOLOGIES</b>	<b>49</b>
3.1	GENERAL	49
3.2	ENVIRONMENTALLY CONSCIOUS DESIGN	52
3.3	ENERGY-EFFICIENCY OF DRIVES	56
3.4	IMPLEMENTATION STATUS IN INDUSTRY	58..

<b>4</b>	<b>CHALLENGES, RESEARCH QUESTIONS AND CHOSEN APPROACH TO LEVERING ECODESIGN IN INDUSTRY</b>	<b>61</b>
4.1	PROBLEM STATEMENT & RESEARCH CHALLENGES	61
4.2	STUDY APPROACH & RESEARCH DESIGN	62
4.2.1	<i>Target</i>	62
4.2.2	<i>Research Design</i>	62
<b>5</b>	<b>METHODS APPLIED IN CONTEXT TO ECODESIGN 2.0</b>	<b>69</b>
5.1	LIFE CYCLE ASSESSMENT	69
5.2	LIFE CYCLE COSTING	70
5.3	ECO-CARE-MATRIX	71
<b>6</b>	<b>DEFINITION OF REFERENCE APPLICATIONS – INCLUDING THEIR SYSTEM DESIGNS</b>	<b>75</b>
6.1	GENERAL: APPLICATION / OPERATION CLASS MATRIX	75
6.2	DISCREET MANUFACTURING: IS-MACHINES	79
6.3	VERTICAL MILLS	84
6.4	DRIVE-SYSTEM COMPONENTS	90
<b>7</b>	<b>“CLASSIC” ECO-DESIGN IN CONTEXT TO THE REFERENCE APPLICATIONS</b>	<b>95</b>
7.1	GENERAL	95
7.2	INDIVIDUAL SECTION MACHINES	95
7.2.1	<i>Goal, Scope &amp; Life Cycle Inventory</i>	95
7.2.2	<i>Results</i>	99
7.2.3	<i>Discussion &amp; Conclusion</i>	108
7.3	VERTICAL MILLS	111
7.3.1	<i>Goal, Scope &amp; Life Cycle Inventory</i>	111
7.3.2	<i>Results</i>	115
7.3.3	<i>Discussion &amp; Conclusions</i>	131
7.4	LIFE CYCLE ASSESSMENT OF MOTORS	136
7.4.1	<i>Goal, Scope &amp; Life Cycle Inventory</i>	136
7.4.2	<i>Results: Life Cycle Impact Assessment</i>	148
7.4.3	<i>Interpretation &amp; Discussion</i>	152
7.4.4	<i>Conclusions</i>	161

<b>8</b>	<b>“ECO-DESIGN 2.0” (APPLICATION-ORIENTED) STUDIES IN CONTEXT TO REFERENCE APPLICATIONS</b>	<b>165</b>
8.1	GENERAL	165
8.2	EXTENDED PRODUCT APPROACH	168
8.2.1	<i>General</i>	168
8.2.2	<i>Workflow and requirements for the semi-analytical model (SAM)</i>	169
8.2.3	<i>SAM main characteristics</i>	172
8.2.4	<i>Application of the extended product approach (EPA)</i>	176
8.2.5	<i>Classification of frequency converters and power drive systems</i>	178
8.2.6	<i>The definition of an eco-design process, including product category rules for life cycle assessments and the content of environmental product declarations</i>	182
8.2.7	<i>Discussion &amp; Conclusions</i>	185
8.3	DRIVE SYSTEM FOR PUMP APPLICATION	188
8.3.1	<i>Goal, scope &amp; Life Cycle Inventory</i>	188
8.3.2	<i>Results</i>	194
8.3.3	<i>Interpretation &amp; Discussion</i>	200
8.3.4	<i>Conclusions</i>	207
<b>9</b>	<b>SUMMARY &amp; DISCUSSION</b>	<b>209</b>
<b>10</b>	<b>CONCLUSIONS &amp; PERSPECTIVES</b>	<b>215</b>
10.1	ECO-DESIGN 2.0 IN A NUTSHELL: THE REVIEW OF ITS CORE REQUIREMENTS IN CONTEXT TO ITS APPLICATION	215
10.2	DIGITALIZATION AND ECO-DESIGN: INTEGRATION OF LCI IN PLM TOOLS	220
10.3	ECO-CARE-MATRIX IN SALES CONTEXT: ECO-VIEW	224
	<b>REFERENCES</b>	<b>229</b>
	<b>ANNEX A: MASTER THESIS ABSTRACTS</b>	<b>251</b>
	<b>ANNEX B: COURSE REPORTS</b>	<b>261</b>
	CAPSTONE PROJECT REPORT: ANALYSIS OF THE EFFICIENCY OF THE ECODESIGN DIRECTIVE IN REGARD TO THE POLITICAL GOAL ON CLIMATE CHANGE	262

PROJECT REPORT: LIFE CYCLE MANAGEMENT AT SIEMENS PROCESS INDUSTRIES AND DRIVES	294
<b>ANNEX C: PUBLICATIONS</b>	<b>315</b>
JP-I: COMBINED LIFE CYCLE ASSESSMENT AND LIFE CYCLE COSTING IN THE ECO-CARE-MATRIX – A CASE STUDY ON THE PERFORMANCE OF A MODERNIZED MANUFACTURING SYSTEM FOR GLASS CONTAINERS	316
<i>Journal of Cleaner Production 141 (2017) 99-109</i>	
JP-II: COMPARATIVE LIFE CYCLE ASSESSMENT OF ELECTRIC MOTORS WITH DIFFERENT EFFICIENCY CLASSES: A DEEP DIVE INTO THE TRADE-OFFS BETWEEN THE LIFE CYCLE STAGES IN ECODESIGN CONTEXT	328
<i>Manuscript submitted for publication in The International Journal of LCA</i>	
JP-III: A NEW, INNOVATIVE SET OF STANDARDS FOR DRIVE SYSTEMS: INTRODUCING AND TESTING THE EXTENDED PRODUCT APPROACH FOR TACKLING THE ECODESIGN OF SYSTEMS IN APPLICATION CONTEXT	378
<i>Manuscript submitted for publication in Journal of Manufacturing Systems</i>	
C-I: COMPARISON OF TWO DIFFERENT APPROACHES FOR A SIMPLIFIED LIFE CYCLE ASSESSMENT OF ELECTRONICS	438
<i>lecture 3.1.2., CARE Innovation 2014 Conference, Vienna</i>	
C-II: NEW STANDARD ON ECODESIGN FOR POWER DRIVE SYSTEMS, MOTOR STARTERS, POWER ELECTRONICS & THEIR DRIVEN APPLICATIONS – INTRODUCING THE EXTENDED PRODUCT APPROACH AND PRODUCT CATEGORY RULES FOR MOTOR SYSTEMS	449
<i>lecture 2.14.1., CARE Innovation 2014 Conference, Vienna</i>	

# Abbreviation List

ACC	Automation Controls & Communication
ACEA	Advisory Committee on Environmental Aspects (IEC)
ADP	Abiotic Resource Depletion Potential
AP	Acidification Potential
BoM	Bill of Material
BU	Business Unit
CAPEX	Capital Expenditure
CBS	Cost Breakdown Structure
CDM	Complete Drive Module
CEMEP	European Committee of Manufacturers of Electrical Machines and Power Electronics
CEP	Circular Economy Package
CLC	CENELEC: European Committee for Electrotechnical Standardization
DBB	Division by Baseline
DfX	Design for X; X = Environment; Recycling; Disassembly;...
DIN	Deutsches Institut für Normung
DTU	Technical University of Denmark
EC	European Commission
ECD	Environmentally Conscious Design / Ecodesign
ECD2.0	Ecodesign 2.0
ECM	Eco-Care-Matrix
EEE	Electrical and Electronic Equipment
EEl	Energy Efficiency Index
EHS	Environment, Health & Safety
EMS	Environmental Management System

EoL	End-of-Life
EP	Eutrophication Potential
EPA	Extended Product Approach
EQV	Equivalents
EU	European Union
EuP; ErP	Energy using Products; Energy related Products
FAETP	Freshwater Ecotoxicity
FU	Functional Unit
GWP	Global Warming Potential
HTP; HT	Human Toxicity Potential; Human Toxicity
IDS	Integrated Drive Systems
IE	International Efficiency (class); Energy efficiency classification
IEC	International Electrotechnical Commission
IES	International Efficiency (class for Motor) System; Energy efficiency classification
ILCD	International Life Cycle Database
IPAT	Impact = Population * Affluence * Technological
IPSS	Integrated Product Service System
IRP	Ionising Radiation Potential
IS	International Standard
IS machine	Individual Section machine
ISO	International Organization for Standardisation
JRC	European Commission's Joint Research Center
KMPP	Flender bevel planetary gear units; product name
LCA	Life Cycle Assessment
LCC	Life Cycle Costing
LCI	Life Cycle Inventory



LCIA	Life Cycle Impact Assessment
MC	Motion Controls
MD	Flender Multiple Drive gear unit
METP	Marine Ecotoxicity Potential
NC	National Committee
NEMA	National Electrical Manufactures Association
NF	Normalisation Factor
ODP	Ozone Depletion Potential
OEM	Original Equipment Manufacturer
OP	Operating Point
OPEX	Operational Expenditure
PA	Process Automation; Siemens PD Business Unit
PCOP	Photochemical Oxidation Potential
PCR	Product Category Rules
PD	Process Industries and Drives; Siemens AG Business Division
PDCA	plan-do-check-act
PDS	Power Drive System
PE	Person Equivalent
PEF	Product Environmental Footprint
PLC	Programmable Logic Controller
PLM	Product Life Cycle Management
PrEP	Product-related Environmental Protection
PSR	Product-specific Rules
QMS	Quality Management System
QSA	Quantitative Sustainability Assessment; DTU Division at Management Engineering Department

R&D	Research & Development
RD	Resource Depletion; fossil/mineral/...
RoHS	Restriction of Hazardous Substances
S&CG	Switch & Control Gear
SAGE	Strategic Action Group on the Environment (ISO)
SAM	Semi-Analytical Model
SC	Standardisation Committee
SFS	Siemens Financial Services
SMB	Standardisation Management Board (IEC)
TC	Technical Committee
TETP	Terrestrial Ecotoxicity Potential
TTP	Table Thrust Bearing
UNEP	United Nations Environment Program
VDMA	Verband Deutscher Maschinen- und Anlagenbau
VM	Vertical Mills
VSD	Variable Speed Drive
WEEE	Waste of Electronic and Electrical Equipment
ZVEI	Zentralverband Elektrotechnik- und Elektronikindustrie



# 1 INTRODUCTION

## 1.1 MOTIVATION AND BACKGROUND OF THE PHD THESIS

The project is motivated out of the context that industry on the one hand is facing a number of concrete challenges regarding documented environmental performance improvement of products and systems (i.e. demand of documented eco-designed solutions) and that, on the other hand, existing eco-design methods lack dedicated consideration of system contexts, which often may lead to unintended sub-optimisations of the overall technical solution/application – all this despite the large existing number of eco-design approaches and despite the fact that some of them might encompass Life Cycle Assessment (LCA), supporting decision-making and results documentation [Bey et al., 2013; Jayal et al., 2010; Duflou et al., 2012].

A specific tool which even considers (economic) customer benefits along with environmental ones and which displays results in an easy-to-understand 2x2 matrix is the Siemens Eco Care Matrix (ECM) [Siemens 2011]. However, this tool needs robust and efficient background methods to deal with the systemic context of several products used together in a given application.

Above-mentioned industry challenges include:

- Lack of methodological support to create insight regarding system-context-depending eco-performance; i.e. lack of generic understanding of environmental performance of the stand-alone product vs. the

environmental performance of the entire solution/application which the product is part of

- During design, lack of guidance towards a structured balancing or combination of early-stage qualitative approaches (e.g. for idea/concept evaluation) and later-stage quantitative approaches (e.g. for product documentation)

- Lack of methodological approaches to design the above in a comprehensive and yet feasible way, applicable in industrial settings – and with regard to special conditions opposed by long application life times and high customer investments that may be involved

In the following the background of the PhD project will be addressed in relation to the underlying main fields, which are

- i) Industrial, automation & drive systems and their components and
- ii) the currently available eco-design approaches.

**Figure 1** below visualizes the basic concept and approach of the thesis in context to the two research fields as cited above.

Based on this the structure of the thesis is as follows: Chapter 1 provides a brief introduction to the topic and the motivation of the project. The research background is outlined in chapter 2 and chapter 3 then describes the currently implemented state-of-art of ecodesign and energy efficiency in industrial environment.

This analysis lead to a detailed formulation of contemporary challenges, the corresponding research questions and the

problem statement, along with the research design that is described in chapter 4. The methods applied when elaborating on the research questions are then described in chapter 5.

In chapter 6 then, the evaluated reference applications are described and in chapter 7 and 8, the results of the dedicated case studies are laid out, summarising from the associated scientific publications.

Finally, chapter 9 summarises and discusses the results of the case studies regarding the Ecodesign 2.0 approach and chapter 10 closes the thesis with conclusions and an outlook of implementation concepts for elements of Ecodesign 2.0 in industrial context.

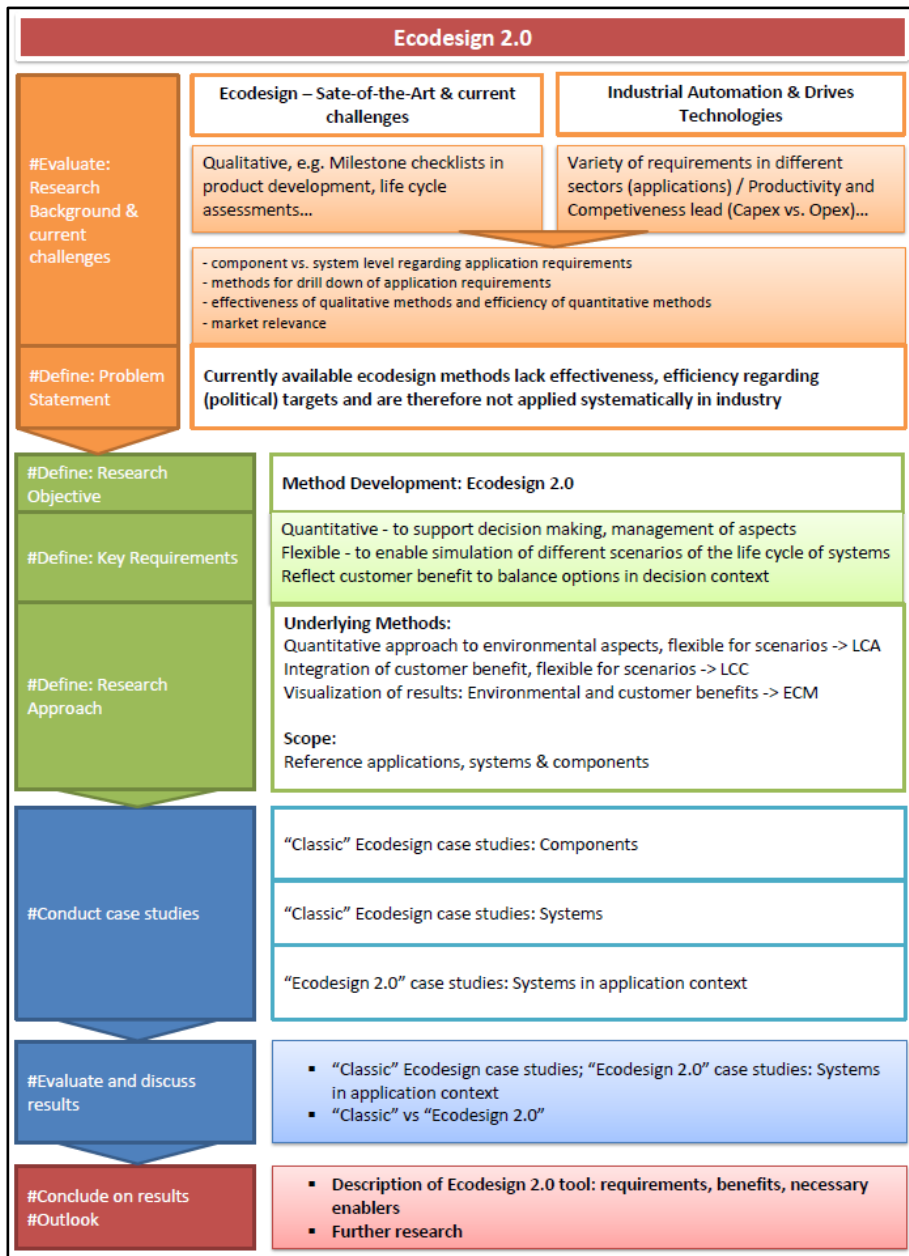

Figure 1: Diagram of the thesis concept.

## 1.2 GENERAL RESEARCH BACKGROUND: SUSTAINABILITY CHALLENGES & SYSTEMS THINKING

This following section summarizes the general research background to this PhD thesis, based on literature reviews and a corresponding course jointly held by DTU, Copenhagen Business School and the University of Copenhagen. It provides the foundation to the motivation of improving the effectiveness of ecodesign from a political, as well as business perspective. It can be stated, that coping with current and future sustainability challenges requires multi- to interdisciplinary systems thinking [COSI 2015], because:

- Business, government and civil society are facing complex sustainability challenges that they cannot solve alone;
- These challenges have technological, engineering, scientific, financial, managerial, political, social and environmental components;
- Tackling them often requires a holistic perspective, partnerships between the private and public sectors as multi-stakeholder initiatives;
- There's the need to develop a common language and understanding with specialists in other fields bridging the gaps between science, technology and business solutions to sustainability.

**Figure 2** was derived to visualize the necessary interaction of involved disciplines and their circular relationship. Natural or



social sciences provide the scientific background for governance institutions like initiatives or policy makers to develop a certain framework. Like for instance the currently developed planetary boundaries, relating environmental impacts to earth’s carrying capacity [Steffen et al., 2015]. Businesses respond to the set framework with the engineering of new solutions or development of technology as well as new business models.

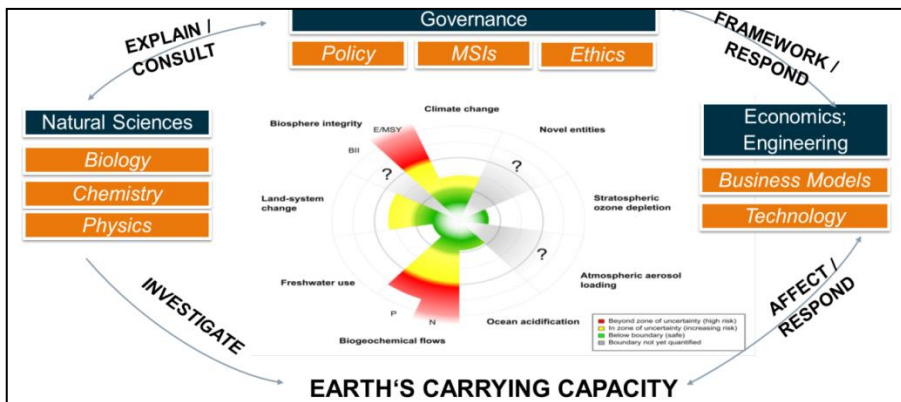

Figure 2: Graphical display of the idea behind “sustainability challenges and systems thinking” [COSI 2015].

Humanity’s influence on the system earth is undeniable; climate change by global warming through certain emissions for instance has finally been accepted as being caused by industrial activities [Roach 2004], whereas debates on that fact have been going for ages, starting from the 70s until – in a political context – today [Oerskes 2004].

**Figure 3** shows the global land-ocean temperature index from 1880 to present and **Figure 4** the fossil fuel related carbon dioxide emissions [GISTEMP 2015].

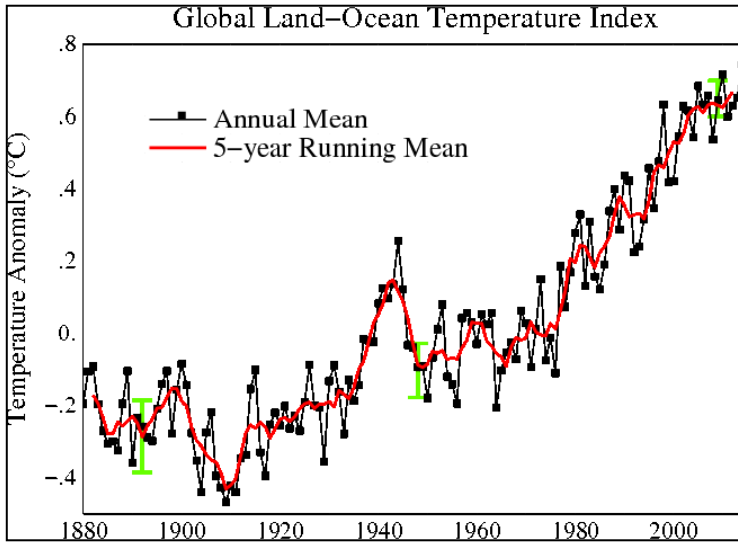

Figure 3: Line plot of global mean land-ocean temperature index, 1880 to present, with the base period 1951-1980. The dotted black line is the annual mean and the solid red line is the five-year mean. The green bars show uncertainty estimates. (This is an update of Fig. 9a in [Hansen 2010]) [GISTEMP 2015].

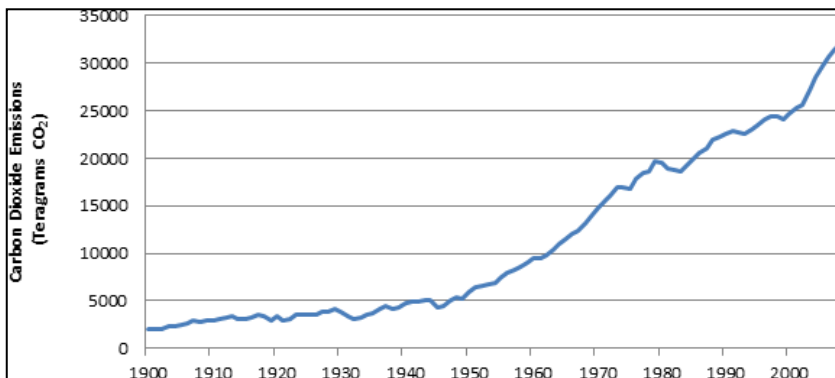



Figure 4: Fossil fuel related carbon dioxide (CO<sub>2</sub>) emissions over the 20th century. Image source: EPA.

Finally, in 2015 at the Paris climate conference (COP21) in December 2015, 195 countries adopted the first-ever universal, legally binding global climate deal. The agreement sets out a

global action plan to put the world on track to avoid dangerous climate change by limiting global warming to well below 2°C. The agreement is due to enter into force in 2020 [COP21].

The Ehrlich equation or simply IPAT equation can be used to quantify the impact of humanity on the environment. The IPAT equation as defined by [Ehrlich 1971] as: Impact = Population \* Affluence \* Technological efficiency, is shown according to further development by Graedel and Allenby [Clini et al. 2010] in **Figure 5**.



**The IPAT equation**

$$I = P \cdot A \cdot T = Pop \cdot \frac{GDP}{person} \cdot \frac{I}{GDP}$$

*(Graedel and Allenby, 1995)*

- *I* is the **environmental Impact**
- *Pop* is the **global Population**
- $\frac{GDP}{person}$  is the **Affluence**, the material standard of living ("needs")
- $\frac{I}{GDP}$  is the **Technology factor** - the inverse of the "eco-efficiency" (being: "created value per impact")

Figure 5: The IPAT equation in (environmental) sustainability context [COSI 2015].

Thinking this through, technology, or rather the technology factor has to play a major role for solving current and future sustainability challenges. Population is steadily on the rise and Affluence assumed to do so likewise or at least to stay on the current level, therefore the only factor enabling humans to keep or better reduce their impact on the environment is technology.

As laid down technology innovations play a major role in providing solutions to sustainability challenges. Business is

framed by governance through policies or initiatives, driven by a political will through governments or non-governmental organizations. For these issues, culture and education of people on sustainability aspects is an important factor. For business, challenges as well as opportunities arise in that context, as indicated, a.o., in [Hall et al. 2003].

A (globally) harmonized and – more or less – predictable business framework is important for sustainable success, whereas for that, and additionally for target achievement, the orchestration of different governance instruments is a core requirement as shown for two sectors by [Lister et al. 2015] and [Henriksen, Ponte 2015]. The orchestration of different governance instruments, means the effective interaction of direct (e.g. energy efficiency levels, substance restrictions) and indirect (taxation, emission trading and levels) regulations, as well as standards or certification schemes, self-regulation (associations) or corporate ethics (corporate social responsibility).

Business response can cope with new, enhanced regulations or initiatives by innovations in technology or new business models (e.g. servizing like car sharing, leasing models or performance contracting). Technology innovations are countless, like for instance in automation (e.g. energy management capabilities) and drive technologies (e.g. energy efficiency, motion control), power generation and distribution and mobility (e.g. emission levels, electric drives) and a major opportunity in regards to dealing with sustainability challenges and the correlation of emission per capita over time as visualized by the Environmental Kuznets Curve [Dinda 2004] in **Figure 6**, is the so-called

technology leapfrog development, like for instance explained for the energy sector by [Goldemberg 1998].

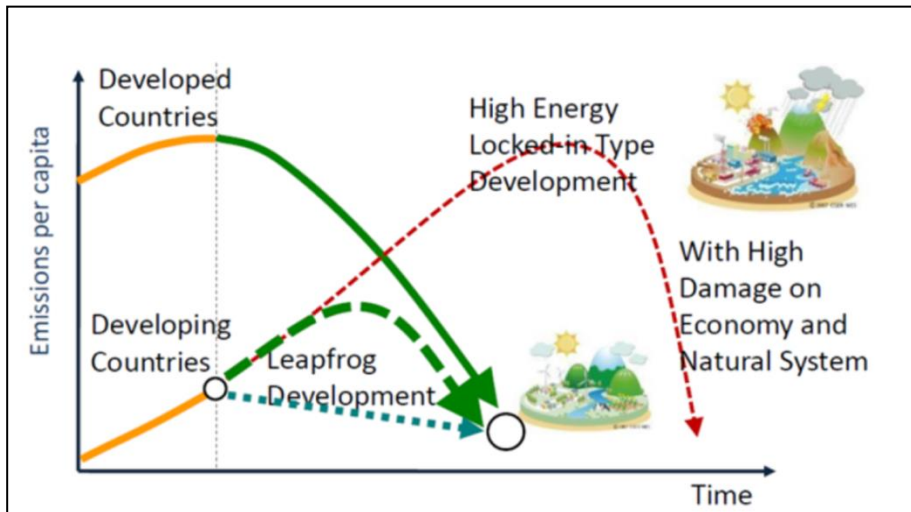

Figure 6: Visualization of "leapfrog development" countering the Environmental Kuznets Curve (EKC) [COSI 2015].

Hence at this point it can be concluded that the important role of technological innovations – driven by an appropriate ecodesign approach – is a key aspect for companies for their business development and for society for mitigating the risks associated with sustainability challenges [McDonough & Braungart 2002].

## 2 BACKGROUND OF RESEARCH

### 2.1 SIEMENS AG

#### 2.1.1 GENERAL

Siemens comprises Siemens AG, a stock corporation under the Federal laws of Germany, as the parent company and its subsidiaries. The Company is incorporated in Germany, with the corporate headquarters situated in Munich. Siemens is a global technology powerhouse that has stood for engineering excellence, innovation, quality, reliability and internationality for more than 165 years. The company is active in more than 200 countries, focusing on the areas of electrification, automation and digitalization. One of the world's largest producers of energy-efficient, resource-saving technologies, Siemens is No. 1 in offshore wind turbine construction, a leading supplier of gas and steam turbines for power generation, a major provider of power transmission solutions and a pioneer in infrastructure solutions as well as automation, drive and software solutions for industry. The company is also a leading provider of medical imaging equipment – such as computed tomography and magnetic resonance imaging systems – and a leader in laboratory diagnostics as well as clinical IT. In fiscal 2016, which ended on September 30, 2016, Siemens generated revenue of €79.6 billion and net income of €6.65 billion. At the end of September 2016, the company had around 351,000 employees worldwide [Siemens 2017a].

Siemens has the following reportable segments: the Divisions Power and Gas; Wind Power and Renewables; Energy Management; Building Technologies; Mobility; Digital Factory;

and Process Industries and Drives as well as the separately managed business Healthineers (formerly called Healthcare), which together form our Industrial Business. The Division Financial Services (SFS) supports the activities of our Industrial Business and also conducts its own business with external customers. As “global entrepreneurs”, Divisions and Healthineers carry business responsibility worldwide, including with regard to their operating results. The Divisions are displayed in **Figure 7**; focus in the context of this PhD study is the Process Industries & Drives (PD) Division.

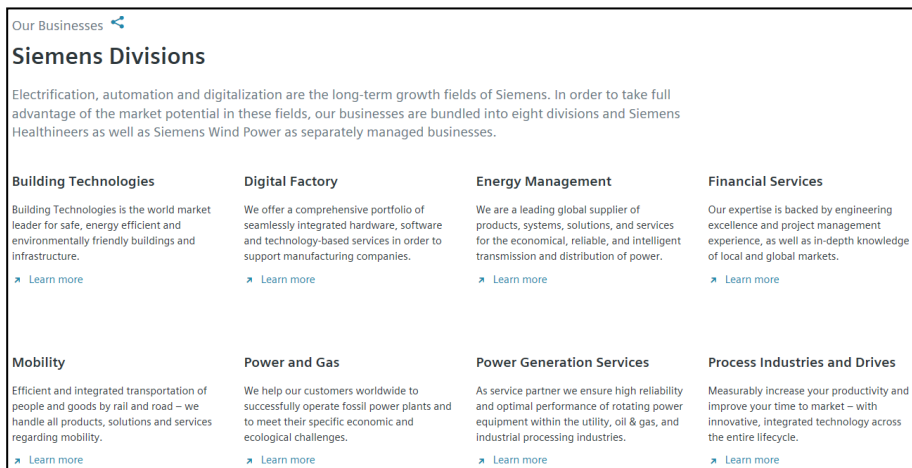

Figure 7: Siemens Divisions as clusters of the operations; Healthineers and Wind Power are not displayed as they are managed separately. Image source: Siemens Intranet.

## 2.1.2 PROCESS INDUSTRIES & DRIVES (PD) DIVISIONS' BUSINESSES

The Process Industries and Drives Division offers a comprehensive product, software, solution and service portfolio for moving, measuring, controlling and optimizing all kinds of mass flows. With its know-how in vertical industries including oil and gas, shipbuilding, mining, cement, fiber, chemicals, food

and beverage, and pharmaceuticals, the Division increases productivity, reliability and flexibility of machinery and installations along their entire life cycle jointly with its customers. Based on data models and analysis methods, Process Industries and Drives paves the way together with its customers to create a “Digital Enterprise”, from process simulation via plant design and documentation through to asset and performance management. The Division’s offerings include an integrated portfolio with products, components and systems such as couplings, gears, motors and converters, process instrumentation systems, process analytics devices, wired and wireless communication, industrial identification and power supplies up to systems level with decentralized control systems, industrial software as well as customized, application-specific systems and solutions. It also sells gears, couplings and drive solutions to other Siemens Divisions, which use them in rail transport and wind turbines. Demand within the industries served by the Division generally shows a delayed response to changes in the overall economic environment. Even so, the Division is strongly dependent on investment cycles in its key industries. In commodity-based process industries such as oil and gas or mining, these cycles are driven mainly by commodity price fluctuations rather than changes in produced volumes [Siemens 2017b].

Siemens PD’s Business Units (BU) are Large Drives (LD), Process Automation (PA), Mechanical Drives (MD) and the Process Solutions (SLN) with products and solutions ranging from high voltage electrical motors, measuring and control equipment to gears and couplings. PD was founded after the last reorganization within Siemens in 2014, to emphasis on the



(indiscrete) process industries like chemicals, pharma or mining [Siemens 2016a].

Core offerings are future-proof automation, drive technologies, industrial software, and services based on platforms like Totally Integrated Automation (TIA) or Integrated Drive Systems (IDS) to develop sustainable solutions across the entire lifecycle – from design and engineering to modernization. Offerings include standardized components, wherever possible, complemented with industry-specific (application-specific) solutions to meet customers’ specific needs in all industry segments. This enables an increased availability of the systems and solutions over the long term, with a strong focus on resource efficiency [Siemens 2015b].

The process industry is one of the core businesses of Siemens. Countless applications, installed throughout a wide variety of industries, demonstrate the expertise. Current developments focus on application specific solutions (e.g. IDS), the integration of digitalization aspects, like for instance remote maintenance and associated services which is displayed in **Figure 8**.

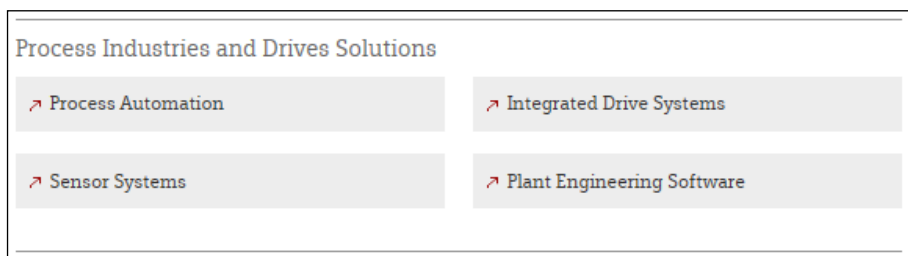

Figure 8: Current key points in the development of the Process Industries and Drives (PD) Division. Image source: Siemens Intranet.

The sales and offerings approach to the main verticals is allocated within the Divisions to certain BU, managing the

14

corresponding activities across all Siemens Units. For PD, as hosting this PhD project, the main verticals, relevant for the definition of reference applications, are: Fiber Industry, Pulp & Paper; Oil & Gas; Marine; Pharmaceutical; Chemicals; Mining, Cement; Glass.

For all these Verticals, it can be stated that on major driver for environmental impacts as well as cost aspects, are the necessary drive systems. This leads to the IDS as a key offering of PD's business to customers, as introduced above, as well as to a first anchor point for the research conducted within this PhD project.

## 2.2 SUSTAINABILITY @ SIEMENS AG: PD DIVISION

Siemens is, as introduced in the previous chapter, a much-diversified business on a global scale. All sustainability aspects do have or can have – more or less – impact on the company and its operations, from the supply chain management to the product life cycle management processes [McKinsey 2011]. Siemens strategy is strongly correlating with sustainability topics through the using the 5 so-called megatrends – Digitalization, Urbanization, Demographic Change, Globalization and Climate Change – for orientation concerning the company's development, e.g. the organizational set-up and the portfolio [Siemens 2016c]. The Megatrends are visualized in **Figure 9**.

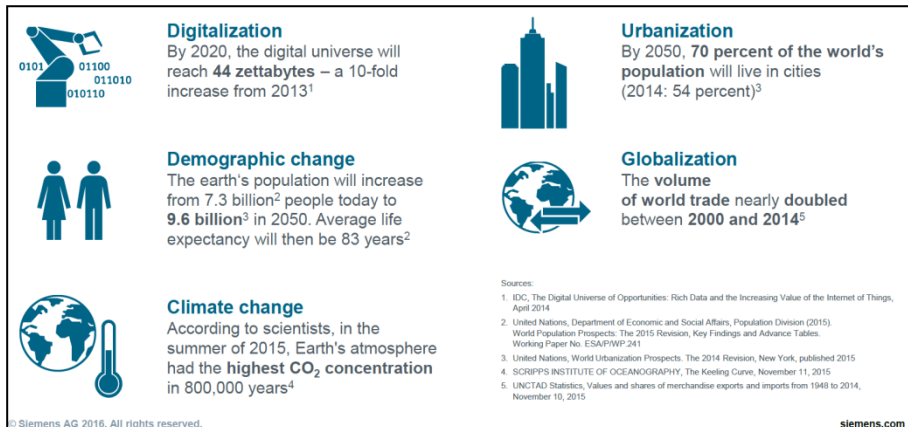

Figure 9: The 5 Megatrends – basis for Siemens strategic orientation. Image source: Siemens Intranet.

**Table 2** now shows the main sustainability aspects of these Megatrends, which should be addressed by Siemens products, services and solutions or have to be coped with in its own operations.

Detailed information concerning Siemens' sustainability approach and related facts and figures can be obtained via the annually provided sustainability information, like for instance in 2015 [Siemens 2016d]. Summarizing these aspects it can be concluded that the main sustainability challenge Siemens has to have on the agenda is climate change and further impacts associated with resource consumption, like ozone depletion and particulate matter. Concerning the economic pillar, as well as the social aspects of sustainability, the globalization provides additional challenges as an increasingly complex supply chain and regulative framework.

Table 2: Identification of the main sustainability aspects associated with the Megatrends.

<i>Megatrend</i>	<i>Remark</i>	<i>Main sustainability aspects</i>
<i>Digitalization</i>	Growth of data processing centres versus reduced resource utilization for prototypes or planning	Resource consumption and associated impacts (Global warming, resource depletion / scarcity)
<i>Demographic change</i>	Population growth and increase of the living standards will affect resource consumption	Resource consumption (Global warming, resource depletion / scarcity)
<i>Climate Change</i>	Effects of climate change have to be minimized and are strongly connected to the consumption of fossil fuels	Global warming; Biodiversity
<i>Urbanization</i>	Growth of megacities which will require an improved management of emissions (connected to resource consumption) to keep / improve living standards	Particulate matter; Land occupation; Acidification and Global warming; water use; waste management
<i>Globalization</i>	Increase of shipments as well as generally travel	Global warming; Biodiversity; Water use

**Figure 10** now visually links the mega trends with the sustainability challenges, which are linked to the planetary boundaries and lead to political responses, e.g. in terms of legislative acts and initiatives, like for instance on Energy-efficiency [2012/27/EU].

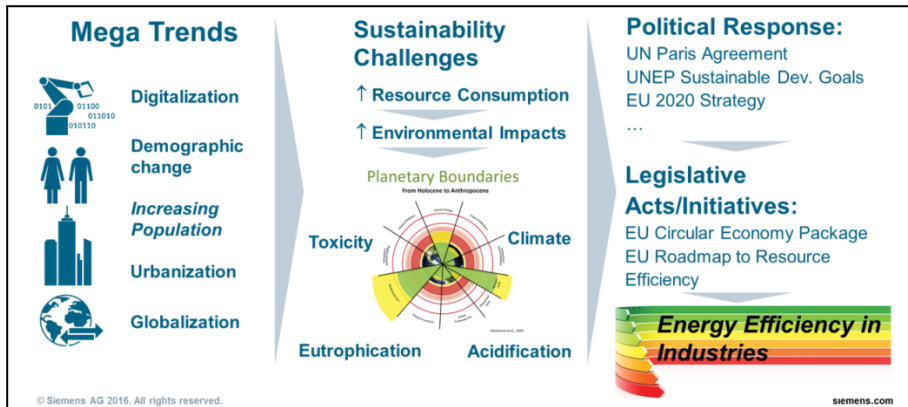

Figure 10: Graphical display of the connection between Mega Trends, sustainability challenges, the political responses in terms legislative acts and initiatives [Auer 2016c].

This basically illustrates that in the context of Siemens' business, there's a link between the strategic orientation of the company and the sustainability challenges. Hence, for Siemens PD, as hosting division to the PhD project, this can be translated into energy or resource efficiency as a key aspect, meaning that ecodesign can be an added value in business development. This will now be described further in the next chapter.

## 2.3 SUSTAINABILITY ASPECTS IN CONTEXT TO SIEMENS PD OPERATIONS

### 2.3.1 ORGANIZATIONAL BACKGROUND

As mentioned above the accountability for sustainability related topics, are in regard to EHS delegated by the EHS principles to the Division CEO [Siemens 2016e]. The Division CEO again delegates his responsibilities topic specific along the chain of command to the third management level, the Business Unit CEO and the factory managers. The remaining duties for organization and controlling are picked up by the respective functional

department: PD EHS. The corresponding reporting obligations – a.o. environmental and occupational safety reporting, environmental risk management – are picked up by these departments respectively. Other functional departments are also affected, but not to that extent, like for instance supply chain management or financial reporting, where the corporate standards, derived from the sustainability principles, like the Code of Conduct etc., have to be implemented.

### 2.3.2 PD APPROACH

Taking off from chapter 2.2, it can be concluded that the *process industries*<sup>1</sup> will be challenged by sustainability challenges, which in the context of automation & drive technologies can be translated into business opportunities along efficiency and productivity of the processes, which also a main aspect of eco-design. Focus in regards to sustainable innovations in the PD Division is the customer productivity, either through providing solution for reducing resource consumption and/or by increasing availability of the production system. One key initiative in this context is the already mentioned Integrated Drive System (IDS), providing integrated products for application specific solutions of complex drive tasks. The concept is described further in section 2.4.3. Another key activity associated is called Energy Efficiency @ Industry (EE@I), synchronizing BU activities in regard to energy efficiency. Both initiatives are set up on divisional level to provide the necessary cross-BU framework. Both initiatives cover aspects of product and service development, as well as sales and marketing, therefore the whole life cycle is taken into account.

---

<sup>1</sup> Process industries in this context means the verticals as mentioned in 2.2; e.g. cement & mining, pharmaceutical, oil & gas.

Additionally an Integrated Management System for Environmental, Health and Safety (EHS) is in place for facilitating the continuous improvement of related processes and performance, including the product life cycle management (PLM) as described in the next chapter.

### 2.3.3 ENVIRONMENTALLY CONSCIOUS DESIGN APPROACH

Basis of the life cycle management at Siemens PD is the Corporate EHS standard for environmentally conscious design, which is based on the IEC 62430 standard. Core principle of the standard, corresponding to the EP standard is the identification of relevant environmental aspects of business offerings within the phase “plan”, to tackle them according within the phase “define” and check the implementation before “commercialisation”. The approach is basically a qualitative checklist approach, defining relevant questions to certain project milestones questions. A quantitative eco design approach is addressed and motivated additionally through (i) having life cycle assessment listed as an optional tool and (ii) by providing an extensive framework for conducting these in terms so called product category rules [Siemens 2016h].

Generally speaking the main challenge of a diversified, global business, like the Division PDs is, is dealing with legal and sector specific requirements for products, therefore the primary target of this approach is to cope with this and assure compliance towards applicable global substances, waste or energy efficiency regulations. A strategic, 10 year time horizon, approach is ensured by a division specific environmental, health and safety program issued by the Division CEO which includes further development of the life cycle management approach by systematically applying the life cycle assessment methodology to

evaluate environmental aspects of products and solutions life cycle. Applying the LCA methodology according to ISO 14040/44 and the ILCD handbook [ILCD 2011] enables companies to assess the main environmental impacts of each of the products life cycle stages and their main drivers. These therefore can be considered in the further development of technological innovations or business cases accordingly.



## 2.4 INDUSTRIAL AUTOMATION AND DRIVE SYSTEMS

### 2.4.1 GENERAL

Industrial Drives and Automation Systems are composed from huge variation of components, facilitating the production in discrete and indiscrete industries, as for instance automotive, chemical, mining and pulp & paper. These systems are engineered to fit the needs in the respective field of production, depending on the application.

In Siemens industry sectors are grouped and referred to as verticals, some exemplarily shown in **Figure 11**. This gives an impression about the potential variety of requirements and their dynamic development and related innovation and investment cycles.

These Verticals now can be further divided into discreet and indiscreet industries or – in other words – parts manufacturing and process manufacturing. Their characteristics will be described further in the next chapter.

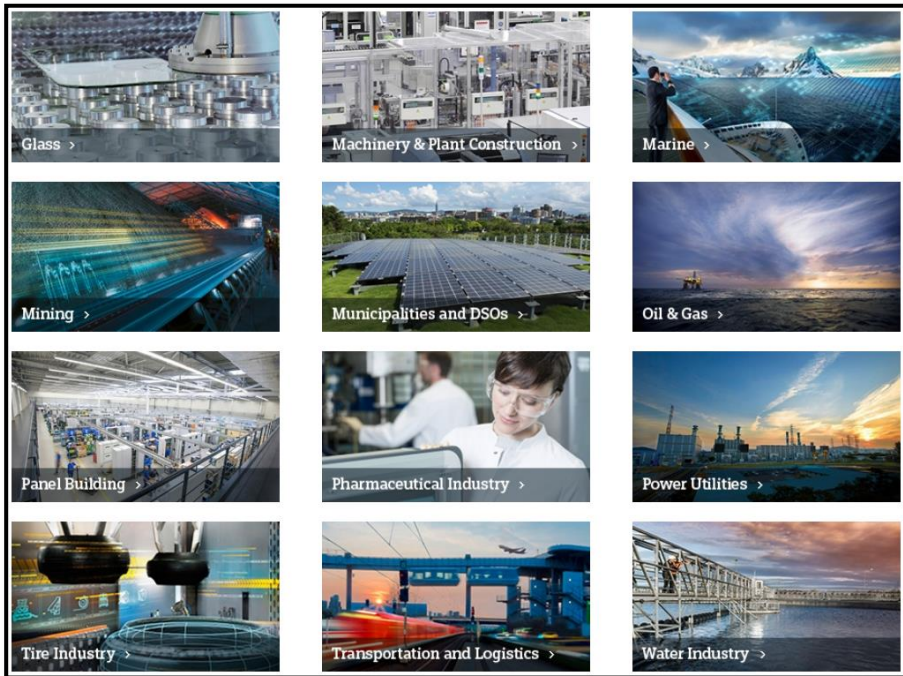

Figure 11: Example of industry sectors relevant for Siemens operations, also referred to as verticals in the context of this thesis. Image source: Siemens Intranet

## 2.4.2 DISCRETE VERSUS PROCESS INDUSTRIES

This chapter is based on [Goetsch 1991], [Plenert 1994], [Groover 2010], [Groover 2012] and [Marsh 2012]. Further, for differentiating and describing the characteristics of discrete and process industries, Siemens internal materials and discussions with experts were used.

Discrete manufacturing is the production of distinct items: Cars, TVs, screws. It is often characterized by individual or separate unit production. Units are produced in a continuous range from low volume with high complexity or high volumes of low

complexity, which either requires flexible manufacturing system or rather standardized tool sets that quickly pay off.

Most discrete manufacturing companies make physical products that go directly to businesses and consumers. A discrete manufacturer uses (multi-level) Bills of Materials (BOMs) and assembles along a routing, therefore discrete manufacturers – including make-to-stock, make-to-order, and assemble to order production facilities – require sophisticated planning, scheduling and tracking capabilities to improve operations and profitability. The products are typically manufactured in individually defined lots, the sequence of work centres through production varying for each one of these. Thus in discrete manufacturing, the product is made by sequential steps made in the same process or by the same craftsman, identified through e.g. serial numbers. Discrete manufacturing's is utilizing after-the-fact statistical analysis to get continuous improvement, as for instance the first pass yield and non-conformance costs, adapting based on order income and stock turnaround times. The processes deployed in discrete manufacturing are not continuous in nature; each process can be individually started or stopped and can be run at varying production rates.

Indiscreet or process manufacturing is rather associated with substances/materials and formulations/manufacturing recipes, than bill of materials and the assembly of components. Process manufacturing is common in the food & beverage, chemical, pharmaceutical and mining industries. The relevant factors are ingredients (not parts), formulations (not bills of materials) and bulk materials (rather than individual units). Although there are various crossovers between the two branches of manufacturing, the major contents of the finished product and the majority of the

resource intensity of the production process generally allow manufacturing systems to be classified as one or the other. For example, a bottle of juice is a discrete item, but juice is process manufactured. The plastic used in injection moulding is process manufactured, but the components it is shaped into are generally discrete, and subject to further assembly.

The formulation in process manufacturing specifies the ingredients and the amounts (e.g., pounds, gallons, litres) needed to make the product, including how to blend (process) the batch. This also indicates another characteristic of process industries, the scalability, which in discrete manufacturing is rather limited. It allows the scaling of processes, as well as to some extent the corresponding manufacturing system, according to the underlying formulation to different batch sizes. In process manufacturing you can make as much of a finished product as is specified in the formula for the smallest quantity in stock of one of the ingredients. But there will be an optimum regarding resource efficiency and productivity. Additionally, the finished product is usually produced in bulk, but is rarely delivered in bulk form to the customer. For example, the beverage manufacturer makes soda in batches of thousands of gallons. However, a consumer purchases soda in 330 millilitres aluminium cans, or in one litre plastic bottles. This introduces the concept of a packaging recipe, defining how the bulk or batch product is processed further to the customer. These, formulation and packaging recipe, change in different cycles and therefore their segregation is essential for an efficient and effective process manufacturing. This batch or continuous operations rely on sophisticated tracking and scheduling mechanisms to keep operations running at peak efficiency.

Making a product that requires a set of processes to be finished, yet each process requires certain needs, therefore, it is better to separate each process from the other while planning and setting the manufacturing requirements thus the processes are better controlled and maintained if they are dealt with separately. The approach in the process industry is direct, real-time control and the obligatory requisite is lot potency and shelf life. Hence, manufacturing in process industries is distinguished by a production approach that has minimal interruptions in the actual processing in any one production run, or between production runs of similar products.

In the end, process manufacturers build something that cannot be taken apart, whereas products from discrete industries in most cases can technically be disassembled again.

Advancing globalization and stronger competition, demand businesses in both discrete and process manufacturing industry to have seamless process control, greater flexibility and cost efficiency. But for both industries the resulting requirements for the underlying manufacturing system will differ according to the needs of continuous versus discrete industries. Corresponding to these requirements, the manufacturing system provider's portfolio character and the specific market and sales approach will differ. In the context of automation and drive technologies this generic statement can be exemplarily translated into the success factor of a portfolio designed corresponding to the requirements on system level, e.g. efficient product-system-service-solutions, related to the amount of time the drives operate at specific operating points, defined by the load and speed of the machine. This profile will be significantly different

from a drive for a large mill processing stones to clinker or a drive for a machining tool, shaping steel parts.

### 2.4.3 INTEGRATED DRIVE SYSTEM (IDS)

Based on conducted research projects and case studies [R-II] [R-III] [R-IV] and [Li 2012], it can be stated that in both types of industries, the underlying drive system(s) usually is the environmentally and economically most influential part. So for the further case studies conducted within this PhD project it was decided to – more or less – focus on the drive system and its components, picking on the Siemens PD Division’s Integrated Drive System (IDS) approach, explained in this section, to deal with the current issues in the manufacturing, either in discreet or process industry set-up. The basic concept behind IDS, the holistic integration of the drive system in three dimensions, is shown in **Figure 12**.

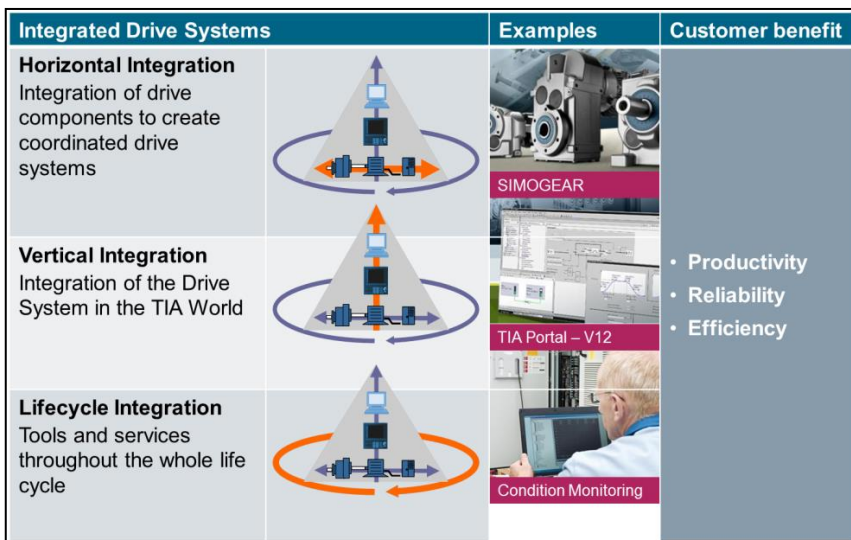

Figure 12: The concept of the Integrated Drive System (IDS) - The Integration of 3 dimensions provides customer benefit in terms of productivity, reliability and efficiency [Siemens 2015b].

IDS can be classified as an integrated product service system (IPSS) [Meier et al. 2010]. With IPSS, resources can be used more efficiently [Lindahl et al., 2014], especially when these aspects are considered in the system's components development [Bey & McAloone, 2006], as for instance machine availability and productivity may be increased by horizontally integrating the drives, vertically integrating the whole automation environment and integrating smart services across [Siemens 2015b]. It basically already picks up the Ecodesign 2.0 idea, because the system or rather the individual components are engineered to suit in an integrated system.

In general, in business-to-business environment of this industrial manufacturing systems, it can be stated that in the current economic, market set-up, for the engineering of such systems (and the underlying components), the functional, technical and economy requirements lead regarding value proposition and not the environmental (or more general sustainability) performance, which currently can be more seen as a second layer or hygiene factor, which means that certain aspects have to be fulfilled as requisites and there's no differentiation factor. A lot in this regard depends on the general and specific economic set-up and/or market environment of the "manufacturer", who is driven either from corresponding customer, regulative requirements and/or his competitive environment. Higher sophisticated process regarding system integration corresponding to increases productivity and efficiency (lower OPEX), are usually associated with higher investment cost (higher CAPEX). Accepting higher investment cost then depends a lot on the acceptance of longer amortization times within a good market environment, whereas price decreases on the end- product will affect this to the

opposite. In any way, because this a customer benefit, for instance assess by the economics performance needs to be addressed in product design and system engineering.

Concerning the environmental performance of a manufacturing system, it can be stated that there is a certain complexity for the assessment due to scale and interaction of components. Further, the systems are usually engineered to the specific circumstances and environment of the project or factory, like for instance the existing production infrastructure, which makes generic assessment approaches rather uncertain. The case study conducted for motors for machine tools [R-III] already indicated the high relevance of the application to the systems design. So, one major issue in this context are interfaces linking or transferring the requirements of the application to the system and its components.

## 2.5 LITERATURE REVIEW: ECO-DESIGN APPROACHES

### 2.5.1 METHODOLOGY

In order to analyse ‘Ecodesign’ as a field of research further in context to this PhD project, a basic, systematic literature review, taking into account [Borrego et al., 2014] and [Greenhalgh 1997], and utilizing the literature databases connected to the library of the Technical University of Denmark (DTU), using the ‘Find it’ search engine [DTU 2017]<sup>2</sup>, has been carried out. The

---

<sup>2</sup> DTU’s ‘Find It’ utilizes, among its library collection, the abstracting and indexing databases: Biosis Previews (1969-), Compendex (1884-), Inspec (1898-), Pubmed (1947-), Scopus (1996-), Web of Science (1899-). Details: [http://api.libguides.com/api\\_box.php?iid=3935&bid=13937966](http://api.libguides.com/api_box.php?iid=3935&bid=13937966)



primary goal was to trace the historical development and to further detail the research questions corresponding to the problem statement. **Table 3** shows the steps taken in terms of the systematic literature review and provides a corresponding description.

Table 3: Basic description of the steps taken in the systematic literature review

<i>Step</i>	<i>Title</i>	<i>Remark / Description</i>
1	Goal & Scope	<p>Goal of the systematic review is to elaborate an accurate picture of past and contemporary available approaches in terms of research and methods.</p> <p>Additionally the picture should include the historic development of ecodesign as a field of research and current implementation challenges.</p> <p>The review should facilitate the elaboration of the challenges of the implementation of ecodesign and corresponding research questions in context of the study.</p> <p>In the scope are peer-reviewed journal and conference publications</p>
2	Inclusion Criteria	<p>Primary data sources that:</p> <ul style="list-style-type: none"> <li>- contain the keywords: “Ecodesign” OR “Environmentally conscious design” OR “Sustainable design” in combination with (AND) “Evolution of” OR “Beginning of” OR “History of” OR “Development of”;</li> <li>- are peer-reviewed (Journal; Conference Proceedings)</li> <li>- available in the literature databases connected with “DTU’s FindIt”</li> </ul>
3	Search database	Records retrieved from database by search function with the keywords
4	Screening	Records screened by abstract to exclude records not matching the inclusion criteria
5	Appraise	Remaining records are appraised by reading the full text in context to the set goal and scope of the review or exclude
6	Synthesis	Remaining records are then included in the qualitative synthesis of the review

By extracting the essence of the publications it is possible to give a historical overview and a description of the development of this topic during the last decades. The results are now summarized in the following sections in terms of an overview of its development and current state of the art in research. For this, the different stages of the development of ecodesign are elaborated by presenting the main content of relevant (journal) publications, along with their temporal and regional distribution.

### 2.5.2 GENERAL OVERVIEW

As laid out in the introduction, the growing consumption of products to satisfy the growing demand of the consumers for affluence and quality of life is a key challenge for society in this century, due to associated negative effects as environmental pollution or resource depletion [McDonough & Braungart, 2002].

During the entire life cycle - from the extraction of raw material to its disposal of waste – a “product”, which in this context is covering offerings as tangible products and services, can cause a lot of environmental impacts. Ecodesign in this thesis’ context should be understood, according to the definition in [ISO TR 14062:2002], as an approach that aims at taking environmental aspects of the product’s life cycle into account during its design and development stage, with the goal of reducing its implications. Today various synonyms found for this approach, are for instance ‘Environmentally Conscious Design’ [IEC 62430:2009], ‘Design for the Environment’ [Stevens 2001] and ‘Ecological Design’ [Shu-Yang et al., 2004], or – according to [Wikipedia 2017a/b] – even as ‘Green Design’ or ‘Sustainable Design’. **Table 4** provides a non-exhaustive overview of

synonyms. Implementation examples would be the reduction of the demand of resources, the increase of a device’s efficiency, minimizing emissions in production and the reduction of potentially harmful and polluting substances.

Table 4: Overview (non-exhaustive) of “Ecodesign” synonyms.

<i>Terminology</i> <i>Ecodesign/Eco Design/Eco-Design</i>
Cleaner Production
Design for Sustainability (DfS)
Design for the Environment (DfE)
Eco Efficiency
Eco Innovation
Environmental Design / Environmentally Conscious Design
Green Design
Green Product Development
Integrated Product Policy (IPP)
Life Cycle Assessment
Life Cycle Design (LCD)
Sustainable Manufacturing
Sustainable (Product) Design / Sustainable Product Development

In the last decades, several quantitative and qualitative approaches have been developed to affect and minimize these impacts, such as LCA [Bhander et al., 2003], which could be used to identify environmental hot spots by a systematic, quantitative evaluation. Nowadays the concept of ecodesign is an integral element of the existing product development process of many companies using different methods as for instance

guidelines and corresponding checklists or quantitative assessments [Pigosso et al., 2015]. The internal and external drivers depend on economic, social or political factors and therefore will differ a lot between companies, including for instance the level of detail relevant in ecodesign. Characteristics of an applied ecodesign method which are important for its success could be e. g. easy adopting and implementing, simplified fulfilment of specific requirements by designers, reducing the risk that important elements are forgotten at development stage or reducing of the time-to-market by standardisation [Betrand et al., 2017]. Starting as a technical topic [Roy 1994], it now can be seen as a holistic approach concerning all business processes of a company as along the whole value chain as laid out for instance by Renee Wever and Joost Vogtländer in [van den Hoven et al., 2015]. Over the years the rather limited scope, e.g. environmental compliance, changed to a complex approach including, e.g. stakeholder and innovation management, as well as fulfilling necessary reporting requirements. Today, whole books as e.g. [Vezzoli & Manzini, 2008] and [Kauffman & Lee, 2013] are available to support the smart implementation of ecodesign aspects into business process landscape of a company, which can be a key factor for a successful business development.

### 2.5.3 HISTORICAL DEVELOPMENT OF ECODESIGN

According to the obtained and appraised records of the literature review, five records were specially dealing with the (historical) development of ecodesign, e.g. [Roy 1994], [Stevens 2001] and [Li et al., 2015]. Especially [Pigosso et al., 2015] and [Jugend et al., 2016] just recently conducted explorative, extensive research based on systematic literature review and bibliometric analysis,

reflecting the evolution of ecodesign in the past 20 years. Hence, only a brief summary will be given in this section. **Figure 13** illustrates the historical development in terms of the growing relevance by the number of records retrieved from the databases connected to DTU's 'Find it'.

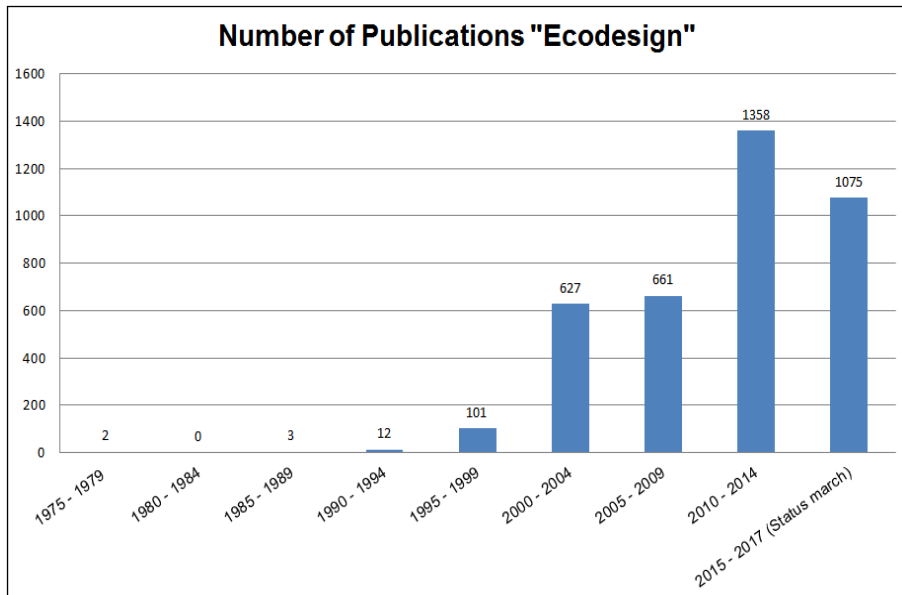

Figure 13: Number of publications using the keyword "Ecodesign" as retrieved via DTU's 'Find it'.

According to these publications, the first steps towards ecodesign have been taken in the seventies, along with ambition to reduce environmental impacts associated with the production. The idea of protecting the environment began during this phase, since resource crisis, pollution or political subjects regarding ecological aspects came up, as an effect of the "industrial revolution" and the increased affluence of certain societies. As a result, there has been an increase of national and regional environmental regulations regarding environmental aspects,

especially concerning industrial processes but also touching upon products [Shu-Yang et al., 2004; Mathieux et al., 2007]. Then in the eighties, even the customers required more and more environmentally friendly products, also leading to manufacturers considering less harmful processes and materials for the design and manufacturing of their offerings [Stevens 2001; Li et al., 2015]. The companies then also recognized that cost savings could be realized through more energy efficiency and less waste volumes, so that in the late eighties the “end-of-pipe” approach and the focus on a “cleaner production” process began to change towards the development of the product, the design stage, as already stated by [Roy 1994]. Since environmental problems, such as climate change, acid rain, waste disposal etc., still increased, or were understood better, the significance of ecodesign and green products rose to a new high in the early 90s. From the 90s onwards the approach then was extended to consider the whole life cycle of a product during the design process, not only the obviously important selection of base materials and manufacturing processes. At this stage, slowly another factor evolved, the strategic dimension of ecodesign, e.g. the risk of losing a competitive position when not addressing environmental aspects already at the design stage [Brissaud et al., 2007].

Hence, in the late eighties, the first structured steps towards ecodesign have been taken in Europe and the USA, based on the awareness created from the [Brundtland 1987] report. For instance in the early nineties, starting as a “project approach” with focus on selected environmental aspects, the PROMISE manual was developed, by among others the University of Delft and the TNO institute for industrial technology, and published in

the Netherlands in 1994. This approach, rated as too academic for application by non-specialists, was more an ‘eco-redesign’ approach, which means that the designs of products were analysed according to the manual to improve with the next redesign [Stevens 2001]. Nevertheless the PROMISE approach helped to establish the Ecodesign concept further and hence was significant for the further development of Ecodesign, in terms of a second version which was published two years later in 1996 in assignment of the United Nations Environment Program (UNEP) as “Promise, a promising approach to sustainable production and consumption” [Brezet & van Hemel, 1997]. This then led to the so-called “manual” approach, by developing environmental design guideline to be incorporated in a company’s research and development or rather design processes. Goal was to ensure that not only “isolated” green projects were carried out but eco-design aspects are systematically addressed in each product development process. According to [Pigosso et al., 2015] it was in this period when eco-design started to really become a matter of research, especially around the topic of integration into business processes as well as supportive tools, like for instance LCA, to support decision-making.

One descriptive example of this eco-design development stage is the “green circle concept”, as shown in **Figure 14**, which also considered aspects like customer requirements, legislation, costs and quality and gave the concept more importance, due to a higher buy in from involved, necessary functions [Stevens 2001]. In the beginning, it was a quite easy but effective approach, by simply addressing three main areas for improvements at the conceptual / design stage: 1. Reduce Energy & Fuel

consumption, 2. Reduce material complexity and 3. Manage end-of-life aspects, until first target conflicts arose.

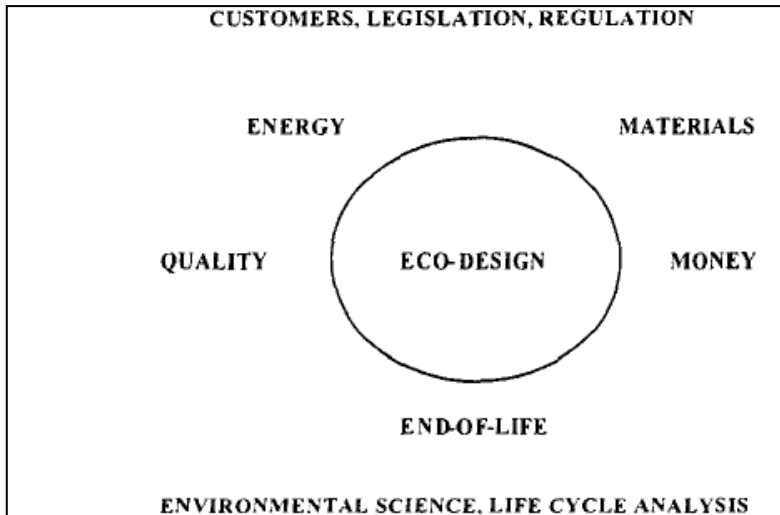

Figure 14: The green circle of Ecodesign activities [Stevens 2001].

Blending in at this development stage was the increasing demand for quantitative approaches. A demand which seemed to be met by the Life Cycle Assessment methodology, which was already established in some industries. This then led to an increase in publications of LCA case studies, as a response to the growing demand for base data (e.g., energy / resource consumption, material efficiency of processes; end-of-life data), as well as environmental indicators and their characterization models. The availability and establishment of LCA software tools and generic datasets were a major success factor for increasing interest in the quantification within ecodesign. Then in the next period, according to the research of [Jugend et al., 2016], from around 2001 to 2010, the fields of research were consolidated around: i) exploring concepts and processes [Bertolucci et al., 2013] and ii) quantitative decision making support, leading to concepts for



LCA integration [Nielsen & Wenzel, 2002] and the evaluation of ecodesign process maturity, like that from [Pigosso et al. 2013].

Looking at the activities of authorities, this is in line with an increase of legislative acts concerning aspects of ecodesign, as for instance for the electronic and electrical industry in Europe the “Restriction of Hazardous Substances” (RoHS) Directive [2002/95/EC], the “Waste of Electronic and Electrical Equipment” (WEEE) Directive [2002/96/EC] and the “Energy using Products” (EuP) framework Directive [2005/32/EC] (further outlined in chapter 3), which also indicates a better understanding of ecodesign approach by the policy makers. This was accompanied by an increase of standardisation projects (also further outlined in chapter 3) related to the subject of ecodesign methods as [IEC 62430:2009], or “labelling” [ISO 14024:1999] and “footprinting” [ISO/TS 14067:2013] standards, or even the concept of “eco-efficiency” [ISO 14045:2012], linking the idea of quantitative environmental data and business process integration. An early example of eco-efficiency [Ehrenfeld 2005] was embedded as an “Ecodesign Matrix” in the “Green Idea Creation” approach [Stevens 2001], shown in **Figure 15**, rating “green ideas” regarding environmental, business, customer benefit along with technical feasibility. Rating and ranking in this regard, again emphasised the topic of quantitative assessments, further extending research around ecodesign, decision making and LCA.

Green Options	Environ- mental Benefit	Business Benefit	Customer Benefit	Societal Benefit	Feasibility Technical/ Financial
First option					
Second option					
Third option					
.					
.					
.					
Nth option					

Figure 15: The EcoDesign Matrix [Stevens 2001].

To summarize and conclude on the historical development of ecodesign, [Li et al., 2015] elaborated a schematic display shown in **Figure 16**, as well as **Figure 17**, also reflecting the results of the literature review.

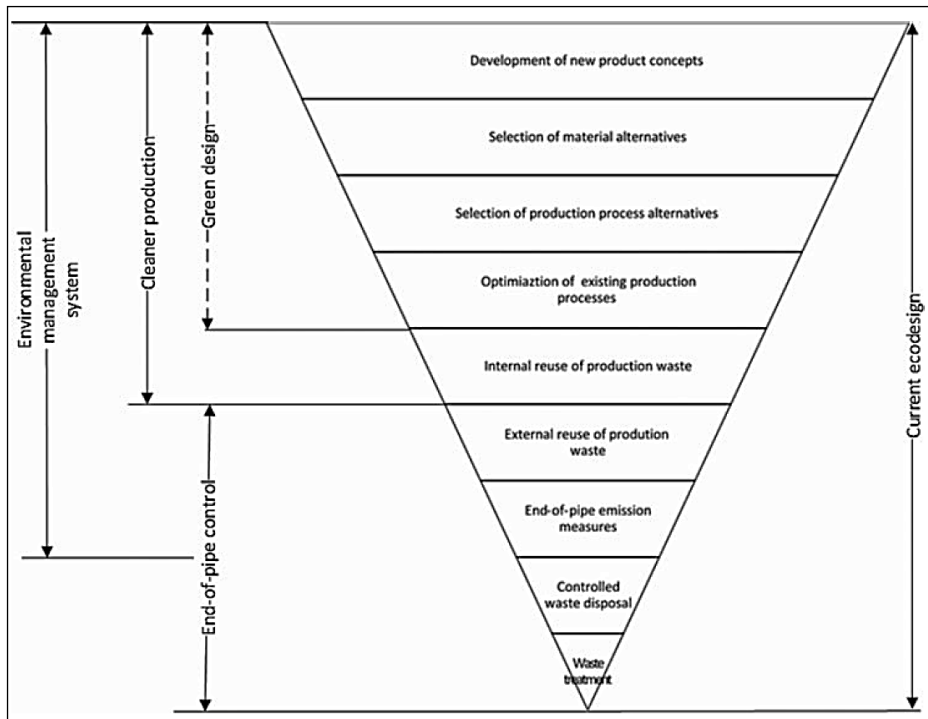

Figure 16: Scopes of green design, cleaner production, environmental management system, end-of-pipe control and Ecodesign [Li et al., 2015].

This **Figure 16** shows the different scopes of the developed ecodesign approaches, as well as their overlaps. It shows that current ecodesign, based on the life cycle thinking mind-set, aims at tackling all aspects, even though the often very relevant use stage is missing a bit in this graphic.

Main message drawn from **Figure 17** is the lagging behind of the application (implementation) of ecodesign approaches, compared to their development in theoretic research. It also shows that in the last decade, in both streams of ecodesign research (theoretical, applied) the routes are on one hand going into details of certain aspects, like end-of-life, and on the other

hand, incremental improvements of existing approaches or methods, as well as their contextualization regarding the companies individual settings.

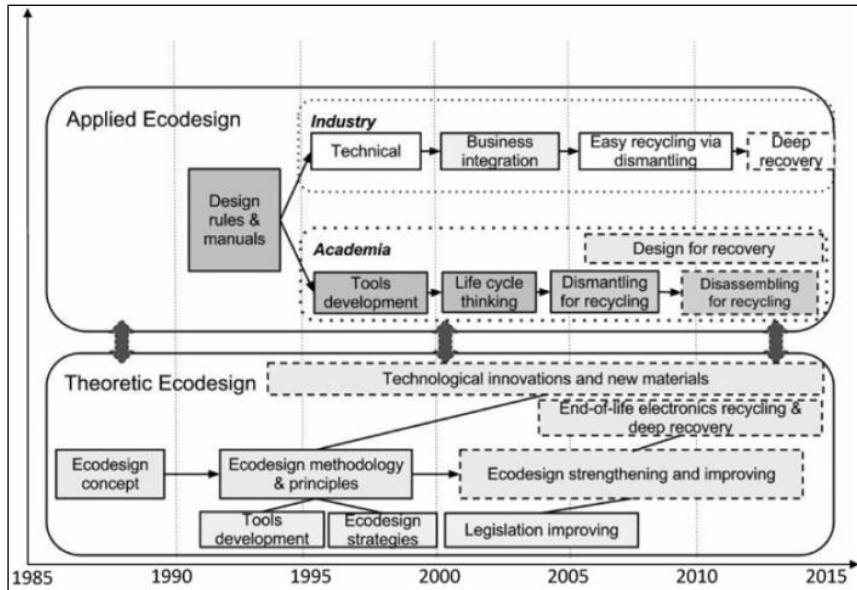

Figure 17: The development of theoretical and applied Ecodesign from the year of 1985 [Li et al., 2015].

[Li et al. 2015] classify the period of ecodesign now as “Maturation and interaction with other management fields”, and it tackles, among others, the research topics:

- Design of product-service systems, e.g. [ElMaraghy 2015; Marilungo et al., 2016; Bertoni et al., 2016]
- Environmental aspects in (project) portfolio management, e.g. [Cluzel et al. 2015; Yousnadj et al., 2014; Brook & Pagnanelli, 2014]

Now, after performing another dedicated research in DTU's literature database, using the combined keywords: "ecodesign" AND "product service systems" AND "portfolio management", it can be concluded that the two research topics mentioned above are still relevant in research and remain open in context to the hypothesis introduced in the beginning of the thesis. This then leads to the next question as described in the goal & scope of the literature review: Analysis of qualitative and quantitative ecodesign methods in context to the requirements of the suggested 'Ecodesign 2.0' approach, is now laid out in the next section.

#### 2.5.4 KEY ECODESIGN APPROACHES AND SUPPORTING METHODS

The development of ecodesign in industry has been dominated by two major drivers: legislation and customer requirements. For instance, traditional sectors like the automotive or electronics sector were concerned earlier and heavier with environmental regulations regarding product design than most other sectors, with some even more-or-less not addressed or affected at all. In Europe, and as well in other regions, Automation and Drive Technologies are a particular target of substance restrictions, waste legislation, energy and material efficiency requirements, either through directly or indirectly applicable directives and regulations, as for instance the already mentioned EuP (or, since 2011, the ErP) Directive, which is analysed in more detail in chapter 3.

Reflecting both of these driver (legislation, customer requirements) in regard to company strategy, business

development and (product) portfolio, and their success factors, this leads quickly to the statement of a necessary business-specific (and therefore company-specific) approach. There is no “One-size-fits-all” approach, but a collection of “best practices”, to be smartly adapted to the needs of a company and their relevant sectors and markets [Mathieux et al., 2007; Bertrand et al., 2017; Telenko et al., 2016]. Which approach is the most suitable for a company depends also on different factors like size of the company, and its particular sector, resources, products, applicable legislation and/or standards. A huge range of ideas, methods, tools and procedures has been developed during the last decades to support the ecodesign concept. As already mentioned, one example for a quantitative tool is LCA, struggling with complexity of the “real world”, as well as an inevitable level of uncertainty [Wenzel et al., 1997; Bhandar et al., 2003; Fleischer & Schmidt, 1997].

The following **Table 5** shows more or less established Ecodesign approaches separated into mainly qualitative or quantitative approaches, as found in the records of the literature review:

Table 5: Different ecodesign approaches, categorized as mainly either quantitative or qualitative.

<i>Approach</i>	<i>Qualitative</i>	<i>Quantitative</i>
Life Cycle Assessment (LCA)		x
CO <sub>2</sub> -Footprint; Footprinting		x
Input/Output-Analysis		x
Environmental Effect Analysis (EEA)		x
Energy & Toxicity matrix (MET)	x	(x)
Environmental Benchmarking	x	(x)
Quality Function Deployment of Environment (QFDE)/ Environmental QFD	x	
Theory of Inventive Problem Solving (TIPS)	x	
Environmentally Conscious Design (ECD)	x	
Design for Environment (DfE)	x	
Checklist-based Assessment	x	
Guidelines / Manuals / “Ten Golden Rules”	x	
Cradle-to-xxx... approaches	x	
Eco Ideas Map	x	
Life Cycle Development Strategy (LIDS)	x	

Now, looking deeper into the content of the records retrieved, it can be stated that there is quite some knowledge on ecodesign available, including supporting methods and approaches for successful implementation. However, it can also be said, that the currently available, applied ecodesign approaches based on quantitative methods as LCA are either

- too lavish and time-consuming, especially when balancing ecodesign decision support with necessary resources and competencies in a competitive market environment;
- or struggle with the availability of respective data and/or the uncertainties of the obtained results.

Quantitative approaches as LCA usually also require specialist expertise and therefore somehow a translation of the results to make them tangible for (product) designers and managers.



On the other hand, when ecodesign is only based on qualitative methods, it is perceived as incapable of supplying the decision support needed to be an effective differentiator in industries built on global, complex supply chains, especially in the current state of potential target conflicts between energy and material efficiency. An additional challenge for qualitative ecodesign is to model scenarios to manage environmental aspects on a larger and prospective scale.

All in all it can be concluded that most ecodesign methods are a kind of mixed (quantitative, qualitative) approaches:

- For quantitative approaches, in most cases assumptions and estimations based on qualitative parameters are necessary in order to keep related necessary efforts on a manageable level, balanced with accuracy of the results.
- For the qualitative approaches, a certain quantitative base is necessary for a proper decision-making [Verghese & Hes, 2007; Allione et al., 2011].

A key is, to find the right balance between quantitative data and its accuracy utilization in, for instance qualitative indicators. Thus to balance, what should be evaluated by quantitative or qualitative methods.

In general, it can be stated that current ecodesign approaches indeed lack an “application view”, especially when intended to be applied in systems engineering for different application scenarios, and further need to be contextualized to the specifics of the implementing company.

### 2.5.5 SUMMARY: ECODESIGN METHODS IN CONTEXT TO ECD 2.0

To summarize the key findings in literature concerning ecodesign, especially drawing from [Bovea & Pérez-Belis, 2012] and just recently shown by [Betrand et al., 2017], it can be stated that there's no approach available up to now that is already considering the specific applications of products/systems appropriately.

For choosing an ecodesign approach in context to this PhD study, the following key aspects have been identified for consideration:

- At first identified key for a successful application (implementation) of ecodesign is the individualization of the existing approaches to a company's specific settings, which is shown in published articles [Allione et al., 2011], as well as in systematic literature reviews by [Jugend et al., 2016; Li et al. 2015]. In this regard, life cycle costing and its application in terms of eco-efficiency can provide the basis of market success or rather the success of the ecodesign process [Widiyanto et al., 2002; Heijungs et al., 2013; Hoogmartens et al., 2014].
- Secondly, a certain degree of quantification of the environmental impacts in ecodesign seems to be necessary, also as a derivative from management philosophy [Drucker 2004] for "If you can't measure it, you can't manage it".
- Then, another key aspect drawn out of this review is the necessary balance between efforts needed for

quantification and the robustness of the results for decision-making, indicated by various approaches for the simplification of LCA [Guinée et al., 2001; Recchioni et al., 2007; Kellenberger & Althaus, 2009].

- At last, the underlying method for quantification should be adaptable to recent scientific or policy developments, like for instance the Planetary Boundaries [Rockström et al., 2009] concept and related concepts such as absolute environmental sustainability [Bjørn & Hauschild, 2015; Ryberg et al., 2016], as well as substance restrictions and energy efficiency regulations.

For the further course of the project, an analysis of the current state-of-the-art of ecodesign implementation in the sector of industrial manufacturing systems (esp. automation & drive technologies) as research background, has been conducted and is outlined in the following chapter 3.

# 3 CURRENT STATE-OF-THE-ART OF ECODESIGN IN INDUSTRIAL AUTOMATION AND DRIVE TECHNOLOGIES

## 3.1 GENERAL

This chapter is meant to provide further background to the research project on ecodesign of industrial manufacturing systems by analysing the current state of implementation. As already stated in the previous chapter, main drivers in this context are legislation and customer requirements, which are in most cases also driven by legislation or similar policies and (end-)customer requirements. For both cases standardisation is a common facilitator, reflecting the current state of art concerning operative implementation. Because of that, the process and its challenges will be described here.

Standardisation is the process of developing technical standards in mutual agreement of various stakeholders, in detail defined in the work modes of the standardisation bodies. Standardisation enhances compatibility, interoperability, safety and quality and it can also facilitate commoditization of formerly custom processes. Therefore the implementation of standards in industry and commerce became highly important with the onset of the Industrial Revolution and the need for high-precision machine tools and interchangeable parts [IEC 2010; ISO 2015; ISO 2016]. International Standards (IS) now provide a common language for the technical world, supporting global trade as a means of preventing technical barriers to trade due to national

standards. Based on the historic development of standardisation bodies on national levels, today there are mainly two well recognized international organizations, the ISO, the International Organization for Standardisation, dealing with general standards like e.g. paper sizes and management systems, and the IEC, the International Electrotechnical Committee, which provides IS for all electrical, electronic and related technologies. Further complexity in a global context aroused through the installation of another level for standards development on regional level.

The European SBs, the so-called European Standards Organizations (ESOs) – CEN, CENELEC and ETSI – were installed by the European Commission in 1973 to foster the harmonization of standards in the European Economic Area (EEA). The regional SBs are also part of the international SBs and the Vienna Agreement [ISO/CEN 1991] provides the foundation of cooperation between ISO and CEN, as the Frankfurt Agreement for IEC and CLC [IEC/CLC 2016]. National Committees (NC) then represent the national interests within the IEC and the ISO, as well as in Europe in the CEN and CENELEC committees by delegating experts to the international or regional standardisation projects and by mirroring these projects on national level. Today, roughly 85 % of all national standards projects are European or international in origin [DIN 2016], whereas most standardisation projects on European level are closely related to European legislation or initiatives. For the further it also has to be considered that there are horizontal standards, defining common rules and requirements applicable to all products, systems or organizations under the scope of the SB, and product specific standards, defining standards for specific products or applications. For that the SBs have set-up horizontal

Technical Committees (TCs) and vertical, product specific, TCs. This is visualised in **Figure 18**.

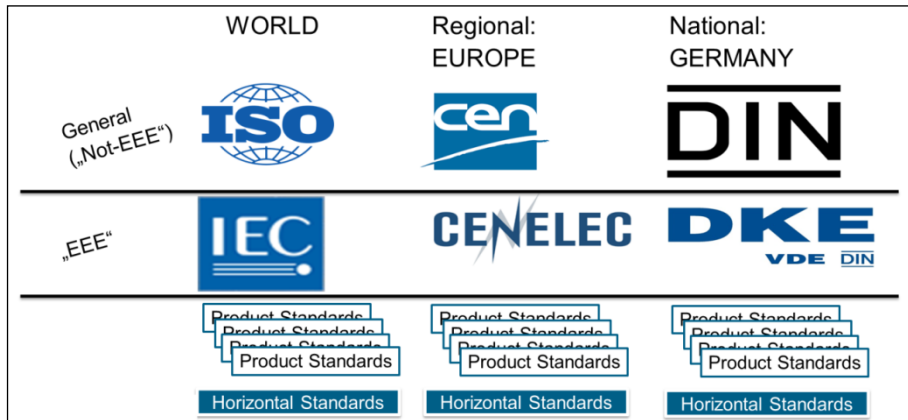

Figure 18: Overview of the three levels of standardisation – international, regional and national – and the corresponding standardisation bodies by the example of Europe and Germany. Vertical TCs produce product standards, horizontal TCs horizontal standards, applicable by or adaptable to the vertical TCs [JP-III].

To summarise, one has to keep in mind that there are three levels of standardisation – global, regional and national – and primarily two organizations or product scopes, the world of electrical and electronic equipment (EEE) and the general world of “non-EEE”. From economic perspective it is favourable to have standards issued on the highest possible level of harmonisation (to avoid trade barriers), but on the other hand often regional or national initiatives initiate corresponding projects on their level. Then, especially when standards are associated with legal requirements (in Europe called harmonised standards), a global harmonization after the standard can get tricky. Additional complexity comes in since EEE is often utilized in non-EEE

products and IEC and ISO requirement should be harmonized or at least be consistent in principle too.

The topic of ecodesign standardisation is now laid out in section 3.2, the policy approach in terms of energy-efficiency for drive systems in section 3.3.

## 3.2 ENVIRONMENTALLY CONSCIOUS DESIGN

As already laid out in the previous section (2.5), did the notion of protecting the environment start with the discovery of significant air, water and soil pollution associated with human activity in the 1960s. This led to environmental protection laws in the 1970s and 1980s, forcing companies to hire environmental specialist to react to this circumstances. The worldwide recognition led to the first International Conference on the Environment in Rio in 1992 and to various voluntary initiatives, standards and guidelines all over the world. Consciousness on the environmental issues of products raised significantly throughout the 1990s, as disruptive technology innovations, especially in electronics, were happening in shorter cycles – effecting business models, products life cycles, as well as consumption patterns – leading to increases in waste and associated environmental impacts. This caused the authorities to tackle this issue by regulations or incentives, as well as through extending the producers responsibility over the whole life cycle.

The different national or regional approaches to this topic led to the demand of standardizing the environmentally conscious design process on global scale. Here the world of standardisation provides a proper foundation and ISO stepped in and assembled a Strategic Action Group on the Environment (SAGE), which concluded after an analysis that standards related to the

management of environmental aspects would help to generally improve the situation, through increase of the environmental performance of the companies and reduce or remove trade barriers, and hence the ISO 14000 standards series was born. In 1992 the ISO/TC207 was founded to develop and maintain the standard series, issuing the first edition of 14001 setting the requirements of an environmental management system (EMS), based on the plan-do-check-act (PDCA) principle, adopted from the Quality Management System (QMS) standard (ISO 9001), in 1996 [Rondinelli & Vastag 2000; Forsyth 1996]. Today a third party certified EMS is worldwide recognized and pretty much expected of international companies. Noteworthy within the ISO 14000 standards, is the technical report (TR) [ISO TR 14062:2002], issued in 2002 dealing with environmental aspects of product design, and is [ISO 14006:2011], providing guidelines for incorporating eco-design aspects into the EMS. Further, there is an [ISO Guide 64:2008], initially from 1997, which guides experts in standardisation how to address environmental issues in the corresponding product standards. Additionally in the current context of quantitative approaches and declarations, the ISO standards ISO 14040/44 defining the Life Cycle Assessment methodology and the [ISO 14020:2000] series [ISO 2012], dealing with environmental labels and declarations, have to be mentioned, since they are correlating to evaluating and expressing environmental impacts of product systems, which is part of the environmentally conscious design process.

On the other hand, IEC picked up that topic too, by installing a dedicated advisory group – the Advisory Committee on Environmental Aspects (ACEA) – which reports to the



Standardisation Management Board (SMB), which considers all aspects of the protection of the natural environment against detrimental impacts from a product, group of products or a system using electrical technology, including electronics and telecommunications, and in 1995 issued a guide on how to include environmental aspects in electrotechnical product standards [IEC Guide 109:2012]. Additionally a dedicated TC, the TC111, was installed and in 2005 the IEC Guide 114 on environmentally conscious design and the integration of environmental aspects was issued by them. This guide then became the already mentioned [IEC 62430:2009], an IS on environmentally conscious design in 2008. In principle comparable to the ISO documents mentioned above. Additionally noteworthy, concerning environmental aspects in the world of IEC standards today, are standards and reports related to materials and substances, like [IEC 62474:2012] on material declaration and the [IEC 62321:2008] series on determination of levels of certain restricted substances (lead, mercury, cadmium,...) from the EU RoHS directive, which expanded its influence to various other regions).

To summarize, ISO 14001 links management of an organization's processes with environmental affects, but does not include design management processes. ISO 9001 covers the design management process, but does not explicitly cover environmental impacts. ISO/TR 14062 and IEC 62430 assist incorporation of the evaluation of environmental aspects and impacts into the design and development process, but as such, they do not fully explain the activities involved within an environmental and business management framework, such as those described in ISO 14001. The connection of these illustrates

the relationship between the aforementioned International Standards, their scope of knowledge and their relationship with this International Standard, which links all three areas and related documents, is illustrated in **Figure 19**.

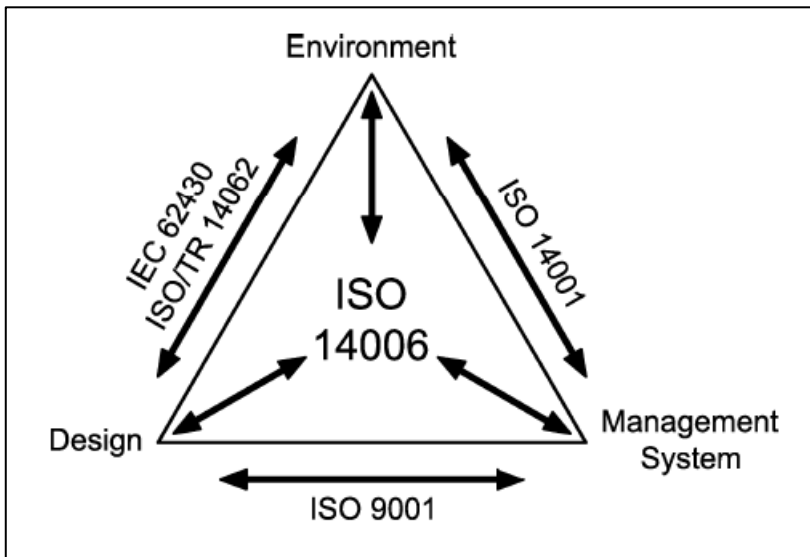

Figure 19: Illustration of the relationship between the aforementioned International Standards, their scope of knowledge and their relationship with this International Standard, which links all three areas and related documents [ISO 14006:2011].

As laid down in the previous sections, the provision of a harmonized, holistic system standard taking its potential applications into account, can get challenging, depending on the product and the associated standardisation world (ISO and/or IEC), as well as the level of the initial demand for the standard (national, regional, world). On the other hand it can be seen as a success factor for supporting ecodesign on a bigger scale by linking the requirements of applications to the underlying systems and their components.

### 3.3 ENERGY-EFFICIENCY OF DRIVES

The aspect of energy-efficiency of drives and especially the motors, as rotating machinery the base of the drive system for converting electric into mechanical energy, has quite some history. Associated standards on performance testing were introduced on national level as early as 1964 (US: IEEE 112), leading then to the IS IEC 60034-2 in 1996. Currently IEC 60034-1:2010 is the state-of-the-art in performance testing of electric motors, and 60034-2-1:2014 for losses determination and efficiency testing. IEC 60034-30-1 then defines the International Efficiency (IE) classes for AC line-fed motors, superseding or complementing the classes defined in the US by the National Electrical Manufacturers Association (NEMA) – standard efficiency, high efficiency and premium efficiency) – and in the EU by the European Committee of Manufacturers of Electrical Machines and Power Electronics (CEMEP) – low (EFF3), medium (EFF2), high efficiency (EFF1). North America (USA, Canada and Mexico) was the leading region for promotion higher efficiency motors through voluntary agreements and legislative acts. In the US in 1992 the Energy Policy Act [EPA 1992] as a governmental act passed by Congress and became effective 1997. Its purpose was to reduce US dependence on imported petroleum and improve air quality by addressing all aspects of energy supply and demand, including renewable energy, alternative fuels, and energy efficiency. EPA 1992 required 1-200 horsepower general-purpose motors manufactured or imported for sale in the United States to meet federal minimum efficiency levels. Continuous development in regard to broadening the scope and increasing the minimum efficiency levels, led to the currently applicable energy conservation

standards for certain commercial and industrial electric motors issued by the U.S. Department of Energy (DOE). Motors covered by the rule include open and enclosed design, 600 volts and below, 1-500 horsepower; 2, 4, and 6 and 8 poles; NEMA Designs A and B. For NEMA Design C, the tabulated efficiencies are the same, but for 1-200 horsepower, 4-6-8 poles only. The effective date of the rule is May 29, 2014 and compliance with the standards will be required for motors produced or imported by June 1, 2016 [Boteler & Malinowski, 2015].

In 1998 a voluntary agreement supported by CEMEP and the European Commission (EC) was established and signed by 36 motor manufacturers, representing 80% of the European production of standard motors. This agreement defined a target to promote more efficient AC 3-phase induction motors, based on the classification scheme (EFF1-EFF3) mentioned above. Based on the classification scheme there was a voluntary undertaking by motor manufacturers to reduce the sale of motors with the current standard efficiency (EFF3). The CEMEP/EU agreement was a very important first step to promote motor efficiency classification and labelling, together with a very effective market transformation. Low efficiency motors (EFF3) have essentially been removed from the EU induction motor market which is a positive development. Still in 2009 Regulation (EC) 640/2009 in context with the EcoDesign directive was issued by the European Commission to set minimum efficiency standards for motors on a regulative basis, applying the IE classes from the IS mentioned above. A shortcoming of the regulation that was claimed then, was the issue of system design

[CAPIEL 2016], the efficiency of the system in context of the application. As explained in the introduction this lead to the standardisation request by the EC to CLC to develop a standard coping with efficiency of drive related systems [CEMEP 2015].

### 3.4 IMPLEMENTATION STATUS IN INDUSTRY

As a closing summary on the implementation status on ecodesign in the automation and drives technologies for manufacturing systems, this section is now drawing conclusions from the ecodesign literature review (section 2.5) and the deep dive into applicable standards and policies (sections 3.2 and 3.3). Further, the industrial host of this project will be the explanatory company example, drawing content from section 2.2.

A basic illustration of the different steps or levels in ecodesign implemented at Siemens PD Division is displayed in **Figure 20**. Therefore, the base is set by the company's code of conduct or business conduct guidelines covering among others legal compliance and aspects of social responsibility (no child labour). For environmental aspects, as well as occupational health & safety, the (certified) ISO Management systems provide the systematic approach for a continuous improvement of associated, relevant processes. Then the next step is taken by integrating ecodesign principles into the product life cycle management (PLM) based on the [IEC 62430:2009] standard. Various manuals and corresponding checklists were developed to suit the different segments of Siemens PD's business. The majority of them are relying on a qualitative approach; quantitative aspects, besides regulated aspects as energy efficiency, are currently an optional topic, only relevant in certain cases where quantitative data is necessary. For instance for supporting the sales approach

or addressing a value proposition by the means of an environmental benefit.

The next level to be achieved in this context, reading the signs of the times for the upcoming, growing demand for quantitative data [PE 2014], the systematic use of LCA is currently under development by the means of a business unit overarching project [Siemens PD 2015] to support its use with generic models and simplification approaches. In the past, before the last restructuring of the company, the facilitation of ecodesign by an eco-efficiency method, the Eco-Care-Matrix, was also a topic in the industrial solution business [Wegner et al., 2009; Wegner et al., 2011] set on top of the “simple” use of LCA by the combination with LCC.

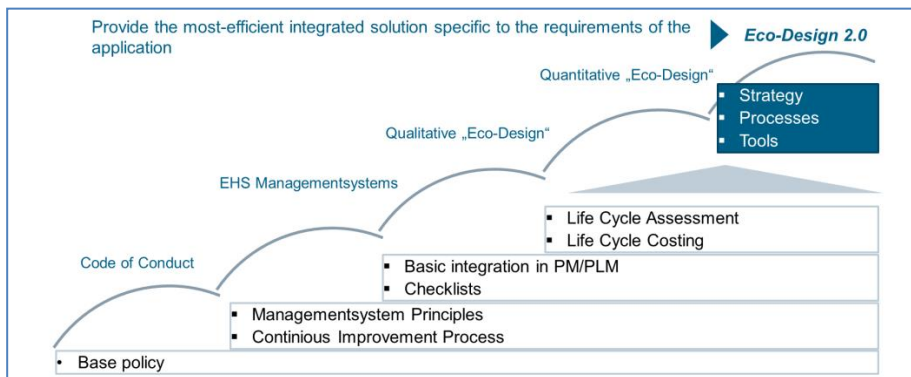

Figure 20: Visual display of the ecodesign levels as defined in Siemens PD. The “aimed at” / “to be developed” Ecodesign 2.0 approach is indicated as the highest level.

Now seizing this foundation in total, an ‘Ecodesign 2.0’ approach can be set on top by further developing the Eco-Care-Matrix and (or rather) the underlying, supporting methods (LCA

/ LCC), to be able to support ecodesign in view of specific applications within the industrial sectors, the verticals.

# 4 CHALLENGES, RESEARCH QUESTIONS AND CHOSEN APPROACH TO LEVERING ECODESIGN IN INDUSTRY

## 4.1 PROBLEM STATEMENT & RESEARCH CHALLENGES

Following the content of the previous chapters (e.g. 2.5 and 3), and taking into account the key aspects identified for the ECD2.0 approach (chapter 2.5.5), the following research challenges were defined:

- There's a lack of methodological support to create insight regarding system-context-dependent eco-performance; i.e. the lack of generic understanding of environmental performance of the stand-alone product vs. the environmental performance of the entire solution regarding the application which the product is part of;
- During design, there's a lack of guidance towards a structured balancing or combination of early-stage (e.g. for idea/concept evaluation) and later-stage approaches (e.g. for product documentation and marketing);
- Finally, there is a lack of methodological approaches to design the above in a comprehensive and yet feasible way, applicable in industrial settings – and with regard to special conditions



posed by long service life times and investment cost that may be involved.

This lead to the following working hypothesis: Instead of dealing with single products, ecodesign of industrial automation and drive technologies has to address the key issue of the solution's usage stage in terms of system design corresponding to the application context, where several products work in conjunction with each other.

## 4.2 STUDY APPROACH & RESEARCH DESIGN

### 4.2.1 TARGET

The primary target of the project was to prove the hypothesis mentioned above (section 4.1) by investigating implemented full-scale reference applications considering environmental and economic facts evaluated over the whole life cycle.

Furthermore, in response to the above challenges and the set target, the overall objective of the PhD project was to create supportive means (tools, methods, models, etc.) in Siemens PD, which stimulate eco-design of solutions through focussing on improving automation and drive technologies in an application system-wide context.

This leads to the research design described in the next section.

### 4.2.2 RESEARCH DESIGN

This backbone of the research includes:

1. Definition/identification of a number of reference applications for drive systems in the process and discrete industries – including their system designs by analysing the respective requirements.

2. Conduction of “classic” eco-design studies (single-product-oriented) of reference applications by exchanging standard components with IDS components (incl. collection of the necessary information throughout the entire life cycle such as resource consumption, wastes etc.).
3. Conduction of “Eco-design 2.0” studies (application-oriented) of reference applications and same component alternatives as in 2.
4. Validation of the two alternative eco-design approaches by comparing outcomes/recommendations by means of Life Cycle Assessment methodology and life cycle costing (customer benefit and environmental benefit then displayed in the Eco-Care-Matrix).
5. Evaluation of eco-design performance achieved/achievable with the two approaches as well as identification of improvement potentials of the developed approach.

Correspondingly **Figure 21** was developed for the ecodesign 2.0 project, based on **Figure 1**, to display key findings from evaluation of the research background (ecodesign; industrial manufacturing systems) shown in blue, analysed requirements for supporting methods shown in green, the collection of conducted case studies (results will be summarized in chapter 6, 7, 8) shown in light grey and finally the results corresponding to the ecodesign 2.0 approach and potential fields for implementation in red.

To respond to these research questions outlined in context to the research background at Siemens PD and in ecodesign generally, it was decided to use an eco-efficiency approach, the Siemens Eco-Care-Matrix (ECM), as facilitator of Ecodesign 2.0 approach. The combination of a sustainability benefit, by the means of an assessed environmental benefit, and a customer benefit is seen as the right approach for the development of systems (and therefore its components), in context with the application, because a customer benefit is very relevant for a value proposition on the market and the provision of answers to environmental aspect can be an additional key differentiator.

For the supporting methods, necessary for the provision of robust values for the Eco-Care-Matrix, it was concluded (section 2.5.5) that they need to be flexible enough to evaluate different scenarios to suit the different settings of the application, in terms of technical features and operating profiles, as well as markets and future scenarios (e.g. local energy mix and electricity costs; development of electricity generation; pricing and depreciation practices). Therefore LCA was chosen as the supporting quantitative method for evaluating sustainability aspects, primarily in terms of environmental impacts, and LCC was

Challenges, Research Questions and Chosen Approach to leveraging  
Ecodesign in Industry

chosen for evaluating the customer benefit, primarily in terms of cost savings, displayed in the ECM.

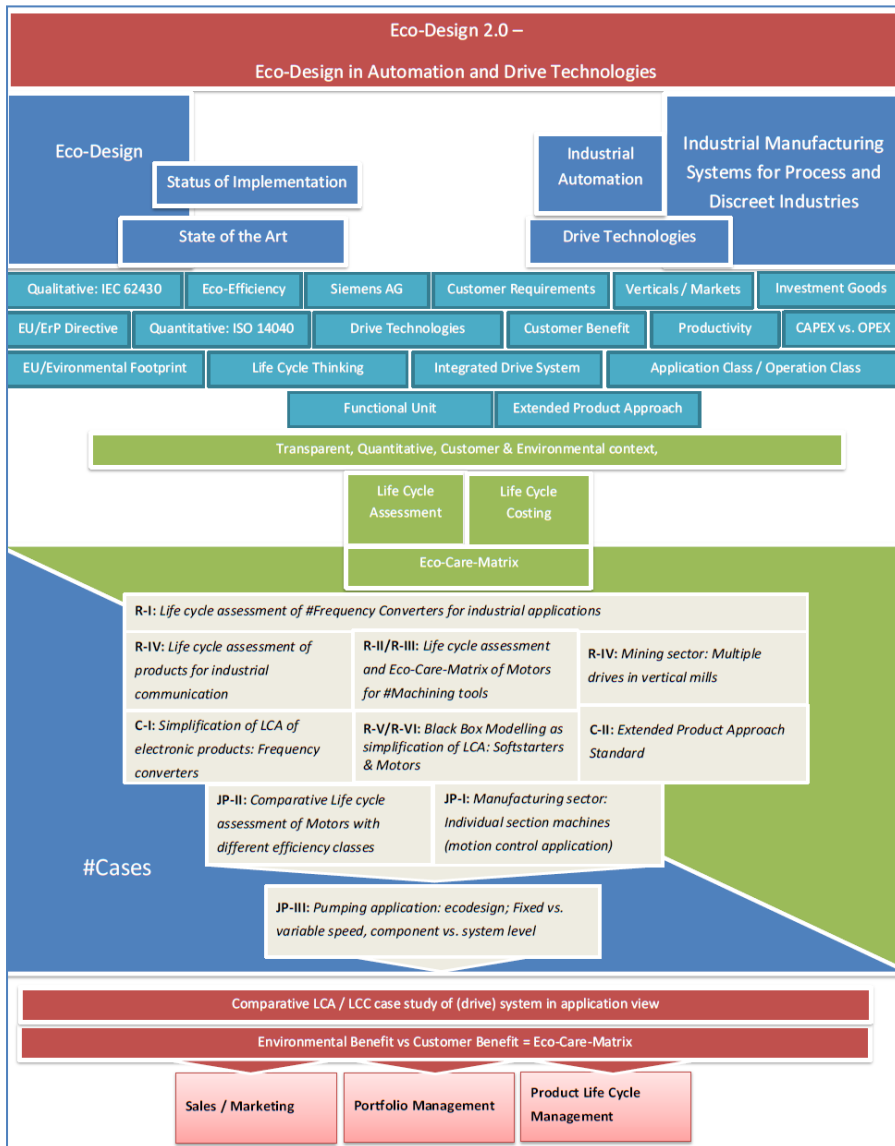

Figure 21: Display of the thesis content (research design), adapted from Figure 1. Key findings from evaluation of the research is shown in blue, the analysed requirements for supporting methods is shown in green, the collection of conducted case studies is shown in light grey and the results corresponding to the ECD2.0 approach and potential fields for implementation are shown in red.

It was then decided to choose one application example from discreet manufacturing and another one from process industries, whereas from the effectiveness point of view the evaluation in context to process industries has a higher priority due their generally more resource intense processes. Anyhow, as already stated there's a certain complexity for the assessment due to scale and interaction of components and one major issue in this context is linking or transferring the requirements of the application to the system and its components.

“Classic” ecodesign in context of this thesis is understood as e.g. environmental hot spot evaluation based on LCA, with a very generic use stage scenario. Preferably the generated results would already be combined with LCC in the Eco-Care-Matrix.

“ECD2.0” ecodesign will look at the situation, taking into account application specific parameters at use stage.

In the next chapter, the supporting methods chosen for conducting the case studies will be briefly described.



## 5 METHODS APPLIED IN CONTEXT TO ECODESIGN 2.0

### 5.1 LIFE CYCLE ASSESSMENT

LCA is a method to quantify the potential environmental impact of products, systems and services over the entire life cycle in order to support sustainable development in organizations [Hauschild et al., 2005], as for instance in glass production [Pulselli et al., 2009]. The LCA was conducted according to the principles laid down in the international standards [ISO 14040:2006; ISO 14044:2006], as well as the ILCD handbook [EC 2010]. **Figure 22** displays the LCA framework by the 5 phases: Goal definition, Scope definition, life cycle inventory, life cycle impact assessment and interpretation <sup>3</sup>. The interpretation includes identification of significant issues (related to the assumptions made, key parameters etc.) and evaluation of these issues through assessment of their sensitivity and influence on the results (sensitivity check), as well as, through the consistency check and uncertainty analysis. Conclusions, limitations and recommendations of the study are then derived.

The arrows indicate the iterative approach of the LCA, according to The ILCD handbook: “The work on an LCA is a systematic process, which involves iterations: Some issues cannot be addressed initially, or only touched on. However, they will be addressed, improved, or revised in the typically 2 to 3 iterations of almost any Life Cycle Inventory (LCI) or LCA study”. This can be operationalized to the fact that the practitioner revises and improves decisions and assumptions taken or estimations made

---

<sup>3</sup> You can also often find Goal & Scope Definition treated as one phase.



in the following phase, e.g. through sensitivity checks and scenario analysis.

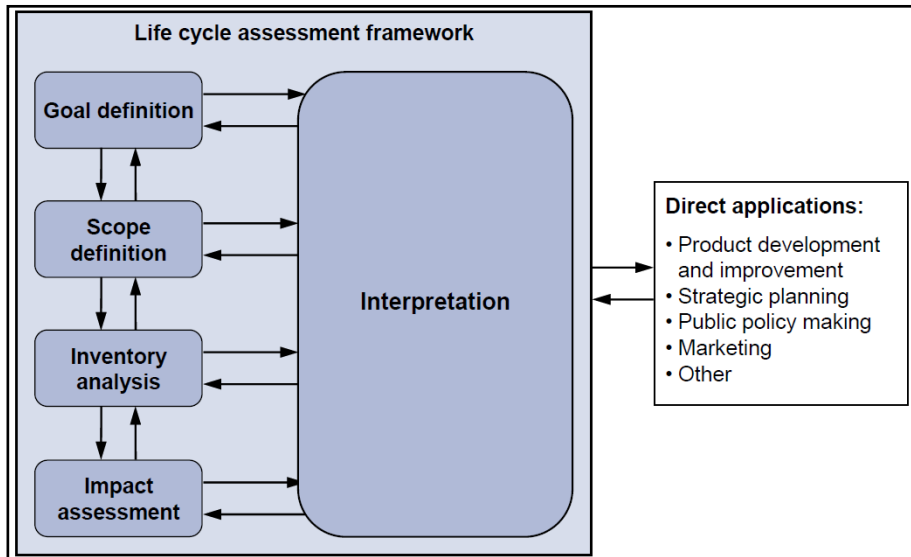

Figure 22: Framework for life cycle assessment (from ISO 14040:2006; modified) [EC 2010].

Further there are, for some products, so-called product category rules available, which are derived from the requirements of [ISO 14025:2006] for environmental declarations, aiming at increasing comparability of the results. For motor systems, as a product category in this project, they are standardised in [EN50598-3:2015]. The software GABI6 and the GABI life cycle inventory databases [Thinkstep 2015] were used for the modelling, if not indicated otherwise. Further details of the LCA approach will be described directly in context to the case studies in chapter 7 and 8.

## 5.2 LIFE CYCLE COSTING

An LCC is a comprehensive decision-making tool for calculating the total costs that are generated over the entire lifetime of

70

products and services [Kádárová et al., 2015]. The execution of an LCC enables the identification of potential cost drivers and cost savings of a product or service over its entire life cycle. By comparing different alternatives, the most cost-effective option can be identified. A variety of methods and approaches has been developed under the umbrella of LCC, due to the heterogeneity and application scenarios of the businesses being analysed. The common aim of the various LCC approaches is to determine the most cost-effective and thus most competitive solution of a product or service [Woodward 1997] and the corresponding steps are shown in **Figure 23**.

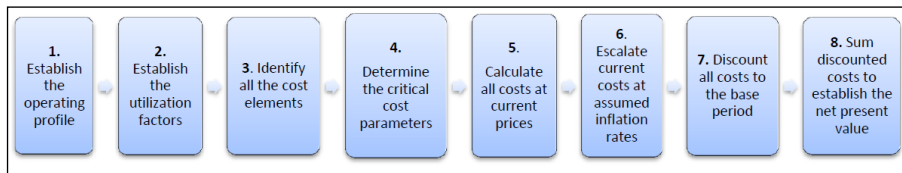

Figure 23: Flow diagram of 8- step approach for LCC [Woodward 1997].

In this case, the LCC, consisting of CAPEX and OPEX (i.e. capital and operational expenditures, respectively), were derived by using a cost breakdown structure (CBS), taking into consideration the principles laid down by [Hui and Mohammed, 2015], in order to analyse the cost-benefit ratio in terms of the pay-off period. To estimate the total energy costs in the case studies, a price of € 0.12 for one kWh of electric energy as an average value within the EU was used according to (Eurostat: EU-28; 2nd half of 2014) [EU 2015].

### 5.3 ECO-CARE-MATRIX

The Eco-Care-Matrix (ECM) is used as a decision-making support tool in portfolio management as well as product lifecycle

management, including engineering. It plots the ecological impact/benefits over economic performance of a product or system compared against a reference, which may for instance be an outdated or an alternative technology. The application of ECM supports the development of products and services that are improved from environmental and cost efficiency perspectives. The ECM can therefore be seen as an eco-efficiency tool, including the challenges associated with the concept of Eco-efficiency, described by [Ehrenfeld, 2005] and further introduced with applications by [Huppes and Ishikawa, 2007].

The results from LCA and LCC are used as basis to assess the environmental benefits over the economic benefits. While the x-axis represents customer benefit as a change in system costs, the y-axis expresses environmental compatibility of a considered application to the reference point. Environmental benefit can be derived by the reduction of an environmental impact. An example for an Eco-Care-Matrix is shown in **Figure 24**.

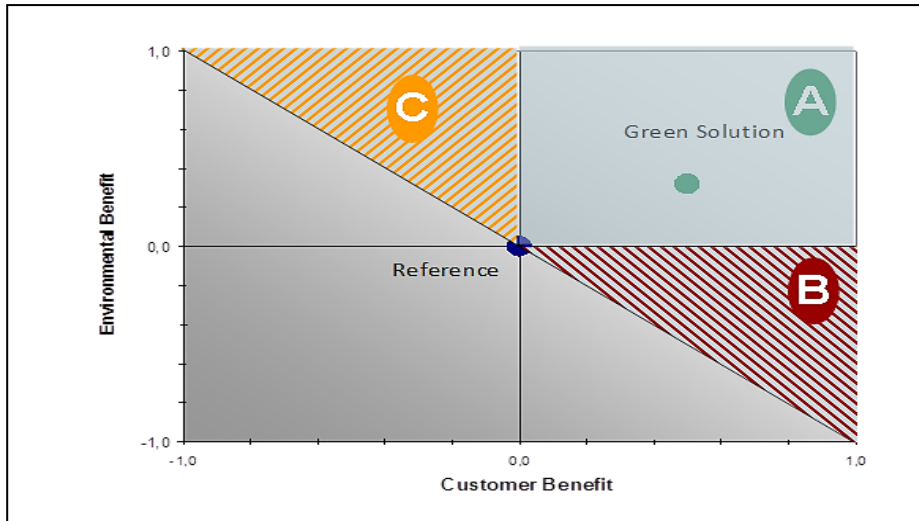

Figure 24: Example of the Siemens Eco-Care-Matrix [Siemens 2010].

The reference point (e.g. traditional technology) is located at the centre of the matrix. While technology/scenario C has higher customer benefits than technologies/scenarios A and B, environmental benefits of technologies/scenarios A and B are higher compared to technology/scenario C. A technology/scenario then can be defined as “green solution”; if the environmental performance is better than the reference at same level of customer satisfaction [Wegener et al., 2011].

In order to achieve a meaningful application – and therefore robust interpretation of the results of the ECM – it is crucial that the whole framework of the underlying LCA and LCC study is consistent, i.e. uses the same system delimitations, data sources/types, background assumptions, etc.



## 6 DEFINITION OF REFERENCE APPLICATIONS – INCLUDING THEIR SYSTEM DESIGNS

### 6.1 GENERAL: APPLICATION / OPERATION CLASS MATRIX

Based on Siemens PD internal material concerning the IDS (Siemens Integrated Drive System), the ‘Application vs. Operation Class Matrix’ shown in **Figure 25** was developed in context to this project. It shows three application and operation classes relevant for the automation and drive technologies in industrial manufacturing system and process industries. Behind the classification are properties of the drive system needed to reply to the requirements of the applications, schematically shown in **Figure 26**. E.g. different speed vs. power/torque profiles, derived from various applications in different verticals, applicable to the drive system [Siemens 2013d; Siemens 2013e].

		Operations class				
		“Fixed-Speed” line fed operation	“Variable Speed”		“Motion Control”	
Application class			Basic	High	Basic	High
	Pumps; Fans	Centrifugal	Centrifugal	Eccentric	Hydraulic	
	Moving;	Belt conveyor	Belt conveyor	Elevator	Accelerating conveyor	
Processing; Machining	Mills (main drives)	Mills (mains)	Extruder	Milling	Drilling	

Figure 25: Application vs. Operation class matrix.

Building this matrix was necessary for the definition of reference applications, that in the further will be evaluated in terms of the ecodesign 2.0 approach. It has to be considered that, along with

the huge variety of requirements of automation and drives systems in industries as described in section 2.4, comes a huge variety of potential parameters for “describing” the application from a functional point of view. It is therefore necessary to first find the key parameters for the function and then, secondly, to build a manageable amount of clusters by grouping certain applications having a good overlap of these key parameters.

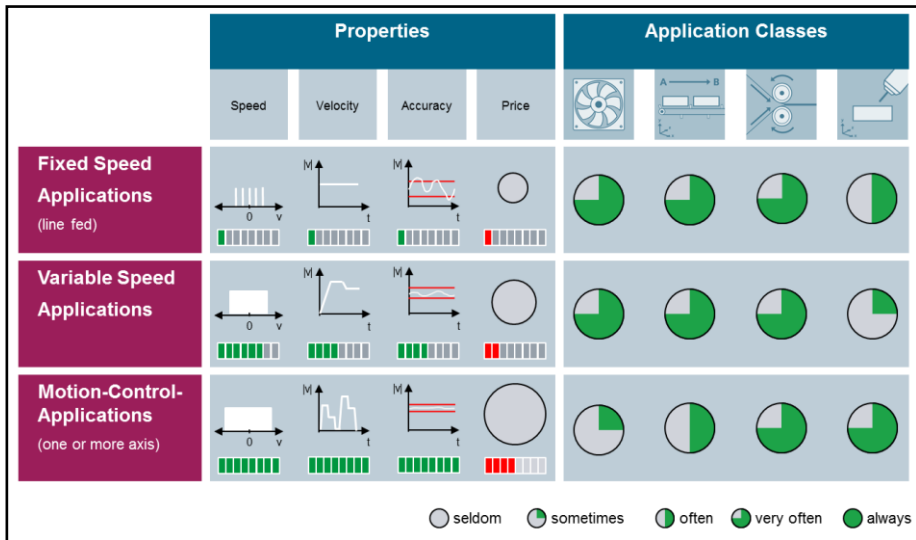

Figure 26: Classification background for application vs. operation class matrix in Figure 25 [Siemens 2013d].

In the case of this PhD project this step was initially essential to find and pick concrete reference applications for the ecodeign case studies, which would already provide a good coverage of the properties spectrum. From the research background, it was derived that the most prominent examples for ecodeign in discreet manufacturing, as well as process industries, are the necessary drive systems, due to the impacts associated with power consumption, electricity respectively. Therefore, the classification approach for the Siemens IDS was used for

Definition of reference applications – including their system designs

defining application / operation class clusters. The IDS itself can already be characterised as an ecodesign approach, since it matches the criteria for the already mentioned IPSS which is established as an ecodesign approach, even reflecting to some extent the application. It has been decided to pick at least a reference application from the field of discreet manufacturing and from the process industries. Then, taking into account the above mentioned matrix, the reference applications should reflect motion control, fixed speed and variable speed. **Figure 27** now shows the ‘Application vs. Operation Class Matrix’ with the chosen reference applications corresponding to the conducted case studies in terms of their reference.

		Operations class					
		“Fixed-Speed” line fed operation		“Variable Speed”		“Motion Control”	
			Basic	High	Basic	High	
Application class	Pumps; Fans	Centrifugal JP-II / JP-III	Centrifugal	Eccentric	Hydraulic		
	Moving;	Belt conveyor	Belt conveyor	Elevator	Accelerating conveyor JP-I		
	Processing; Machining	Mills (main drives) R-IV	Mills (mains)	Extruder	Milling R-II / R-III	Drilling	

Figure 27: Application vs. Operation class matrix indicating the conducted case studies corresponding to reference applications.

Further, by picking the case studies from externally communicated IDS implementation examples, the risk of not accurate, not available data and/or pure theoretical examples is limited, hence the validity of the results and their generalisation increased.

In general, building this matrix can be seen as the first step of an ecodesign 2.0 approach. It is necessary to find a common ground in terms of functionality / properties for the managed product



portfolio's features. This is basically about defining a proper interface between the application and the system and its components.

Corresponding reference application selected for conducting ecodesign case studies were:

- “classic” ecodesign: A ‘processing/machining’ application from operation class ‘motion control’ (discreet manufacturing) – Machine Tools [R-II; R-III];
- “classic” ecodesign: A ‘moving’ application from the operations class ‘motion control’ (discreet manufacturing) – Individual Section (IS) machines [JP-I];
- “classic” ecodesign: A ‘processing/machining’ application from the operation class ‘fixed / variable speed’ (process industries) – Vertical Mills (VM) [R-IV];
- “ECD2.0”: A ‘pumps/fans’ application from the operation class ‘fixed / variable speed’ (process industries) – Centrifugal pump [JP-III];

The chosen reference applications, IS machine and VM, will now be further described in the sections 6.2 and 6.3. Additionally it has been decided to further analyse the components of drive systems regarding ecodesign and the respective correlations between component and system level. The drive system components will be described by the introduced IDS portfolio (section 2.5) in section 6.4.

## 6.2 DISCREET MANUFACTURING: IS-MACHINES

The reference application picked for discreet industries, is a manufacturing system based on individual section machines (IS machines), as used in the container glass industry [Diehm 2007] and were originally invented as the automated bottle-making machine by M. Owens in 1903 [Paquette 2011; ASME 2015]. Such machines enable a simultaneous and automatic production of container glass from a constant feed in terms of a glass smelt.

The basic concept of the solution is visualised in **Figure 28**, as used in container glass manufacturing [Trifonova & Ishun’kina, 2007]. In the end, it’s more of a hybrid system between discreet and continuous, process manufacturing than a classic discreet manufacturing system, like the assembly of a mobile phone. Still it is seen as an appropriate example for discreet industries regarding ecodesign, since the processes side of the application are not in scope, but the discreet side of controlling (synchronization) the shaping and moving of the glass containers is quite demanding and intensive due to the integration of up to 12 individual sections fed by one feed of glass smelt and cooled down in one Lehr.

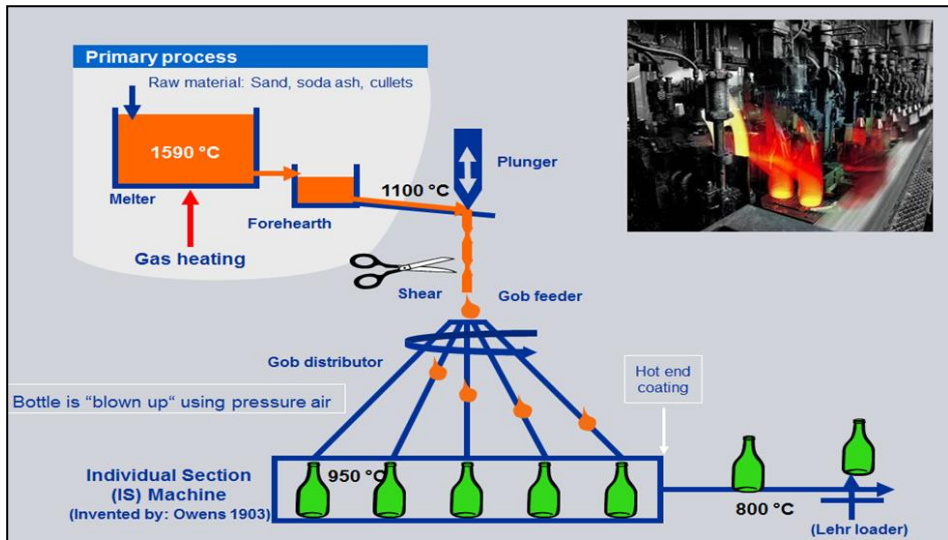

Figure 28: Concept of current Individual Section (IS) Machines as applied in glass container manufacturing [JP-I].

In this specific set up, the previously used hydraulic and pneumatic technologies have been modernized by employing electronic servo drive technology and a motion control concept [Sklostroj 2015], which is part of the Siemens integrated drive system philosophy (IDS). IDS supported as for instance machine availability and productivity have been increased by horizontally integrating the drives, then vertically integrating them into the whole automation environment and finally adding serviceability [Siemens 2015a; Siemens 2014a]. **Figure 29** provides a schematic overview of the solution with servo drive components, and **Figure 30** shows how the new innovated solution has been designed. The predecessor solution, mostly involving pneumatic and hydraulic systems, will in the further be referred to as “System A” and the successor system, using mostly electric servo drives, will be referred to as “System B”.

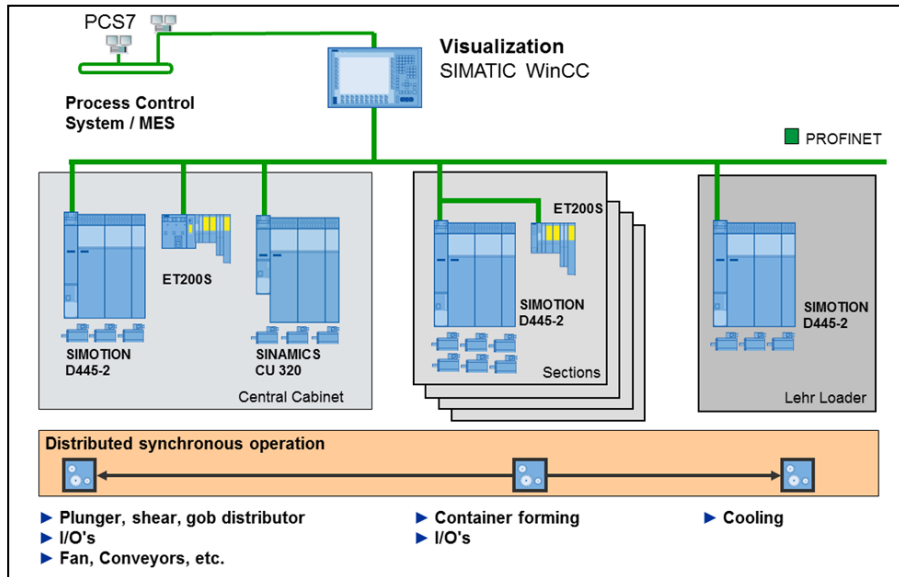

Figure 29: Integrated Drive System applied to the IS Machines [JP-I].

The most critical part of the manufacturing process is the shaping of the glass containers. By using servo drive solutions, the requirements relating to the shaping process, e.g. availability, throughput and robustness, can be met and increased compared to pneumatic or hydraulic solutions. The use of the control system enables several benefits to be obtained for the IS machine, e.g. generation of even and consistent gobbs (i.e. liquid glass pieces) by the plunger as well as accurate and dynamic cutting using the shears. This ensures a reliable distribution to all sections of the machine and thermal stability of the whole system, therefore increasing the quality of the end-product and the yield, which in turn improves the productivity of the overall system.

There's one central cabinet for automation and control of the plunger, shear, etc., then decentralized cabinets for each

individual section (as many as there are operated sections, i.e. 8 in this setting, whereas 12 are currently under development) and the controlled cooling of the formed containers. The complete system is then connected to a Process Control System (PCS) or Manufacturing Execution System (MES) by Profibus communication.

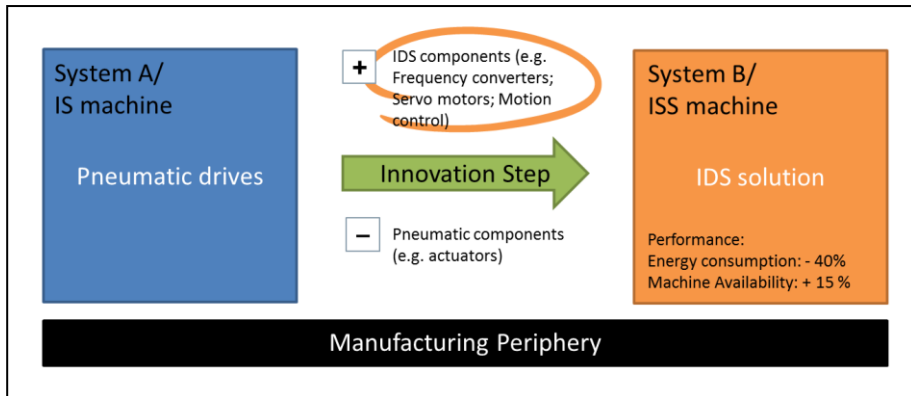

Figure 30: Graphical display of the innovation step through the integration of IDS components (servo drives, motion control system) [JP-I].

Further, the use of smart automation and motion control components, supported by sensors and communication interfaces, allows individual sections or parts of the system to be maintained without putting the whole production on hold.

This fully automated production system leads to an output of about one glass container per second. In the predecessor system, actuators and controls were driven by compressed air, whereas in the innovated version, these are driven by highly efficient electric servomotors. Results achieved through the machine and process redesign, are a reduction of energy consumption of about 40 % and an increased availability of the system of about 15 % [Siemens 2015a].

Definition of reference applications – including their system designs

**Table 6** gives an overview of the servo drive components used to modernize the production system, and the allocation of the components to certain functions. These components are the basis for the comparative LCA to evaluate the additional burden in the manufacturing stage by enhancing the system with electric servo drives and motion control. The total weight of the components used to modernize the system was about 2.2 tons.

Table 6: Overview of the servo drive components and their function group, needed to modernize the IS machine.

<b>Associated function group: Description</b>	<b>Amount [no. of pieces]</b>	<b>Mass [kg] per function group</b>	<b>Percentage by mass of the whole system</b>
<b>Automation Controls &amp; Communication (ACC);</b> needed to control/automate the whole manufacturing system	292	49.38	2.26
<b>Motion Controls (MC);</b> needed for the control including synchronization of the movement of the drive systems	18	56.25	2.57
<b>Variable Speed Drives (VSD);</b> allow exact control of the torque and speed of the motors	145	672.50	30.77
<b>Motors;</b> transfer electrical energy to mechanical power in order to move parts	103	1,385.64	63.39
<b>Switch &amp; Control Gear (S&amp;CG);</b> needed to start, monitor and break operations	74	22.05	1.01
<b>Total</b>	632	2,185.82	100

Further details on the system can be found, along with results, in the corresponding section 7.1.

## 6.3 VERTICAL MILLS

The reference application picked for process industries, are vertical mills (VM), where Siemens provides the corresponding motor systems, engineered further to fit the individual mill application.

VM are used for grinding mineral raw materials such as limestone, clinker, slag, lime, gypsum and ores for the building industry and coal for coal preparation. Commuting of coal is mainly used for heat production in cement industries and power plants. VM reduce material from a thickness of 30 mm to a very fine-grained material [Siemens 2014b]. These machines, have a weight of more than thousand tonnes, and are expected to operate almost 24/7 for 20 years, having a high impact on energy consumption. Therefore, vertical mills and especially their drives, contribute to a number of environmental impacts, such as Global Warming Potential among others.

The working principle of VM is as follows: the raw material is fed from the feed chute and directed to the centre of the rotating grinding table of the mill (**Figure 31**). Under the effect of centrifugal force, the material is transported to the edge of the grinding table where it is crushed by the stationary grinding rollers. When the material falls out the edge, it is directed to the separator by the use of hot gas stream. At the separator, the coarse material is rejected and transported back to the grinding table for re-ground. The pulverized material is transported from the separator and is conveyed from the mill with the use of gas stream [Siemens 2014b].

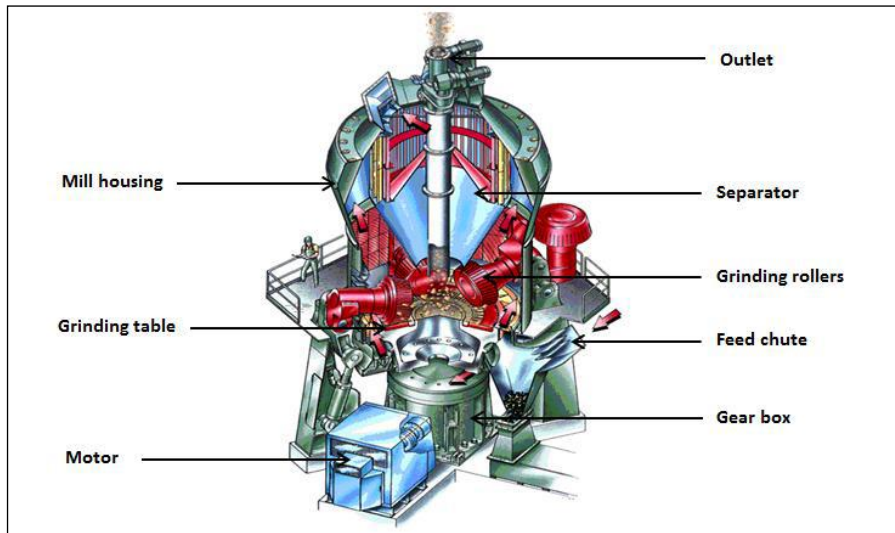

Figure 31: Vertical Mill (source: Siemens internal presentation (labels added)) [R-IV].

The VM is driven by an integrated drive system, which is connected through the gear unit; it functions as the electric motor and absorbs the roller forces due to the thrust bearings. The drive consists of gearbox together with the motor and auxiliaries, which are installed under the vertical mill.

In order for VM to provide its main function, i.e. grinding, the VM use input flows such as electric energy, lubrication oils, water and compressed air, all of which are considered to be cheap sources that can be excessively employed to ensure high quality production. However, efficient use of these resources has been growing due to increasing environmental awareness. In fact, it has become important for organizations to quantify the entire life cycle of the milling machines to identify areas for improvement in design, processing, and resource use [Diaz et al., 2010].



High power ratings are required for VM operation, which are provided by the drive unit. The gear unit transmits the power, adjusts the motor speed to the required one by the mill, and supports the grinding table. The high axial forces generated by the grinding process are transmitted to the foundation via a thrust bearing and the gear housing. The drive system is therefore, a very important element of the VM [Siemens 2014b]. There are five different types of VM drives in Siemens product portfolio which differ depending on the target product: KMP, KMPS, KMPP, EMPP and Multiple Drive. The VM drives have a capacity range that varies from 2,000 kW to 16,000 kW. The low to medium capacity range drivers are KMP and KMPS which are used for pre-grinding and coal production respectively. While for large scale production, the medium to high capacity range drivers are primarily used for clinker and slag grinding, such as FLENDER KMPP, FLENDER EMPP and FLENDER Multiple Drive. FLENDER KMPP, is a commonly applied solution, and FLENDER Multiple Drive®, is the latest developed technology [Siemens 2013; Siemens 2014c], shown in **Figure 32**.

The FLENDER KMPP drive is the most often used in the medium to high capacity range (from 3,000 to 8,000 kW) for clinker and slag grinding. It consists of the following components: Gearbox; Coupling; Oil supply system; Piping; Motor.

The main components of the gear unit are housing, bevel gear set, sliding bearings and sealing. The housing is made mainly of cast iron or steel, and its main function is to keep low the stress and strains from the grinding process. The bevel gear set is made of quenched and tempered steel, designed as a high power gear. It consists of two planetary gear stages that are supported by

Definition of reference applications – including their system designs

sliding bearings and axial pad thrust bearings, which take in the dynamic loads. Temperature is monitored by temperature sensors. The lubrication and cooling is provided by the oil supply system, which continuously recirculates oil to different components (e.g. the axial pad thrust bearings of the gear unit) to absorb the axial forces that result from the grinding process and the mill [Siemens 2013a]. The motor (H-compact®) is squirrel-cage rotor type with a housing made mainly of cast iron. [Siemens 2013b].

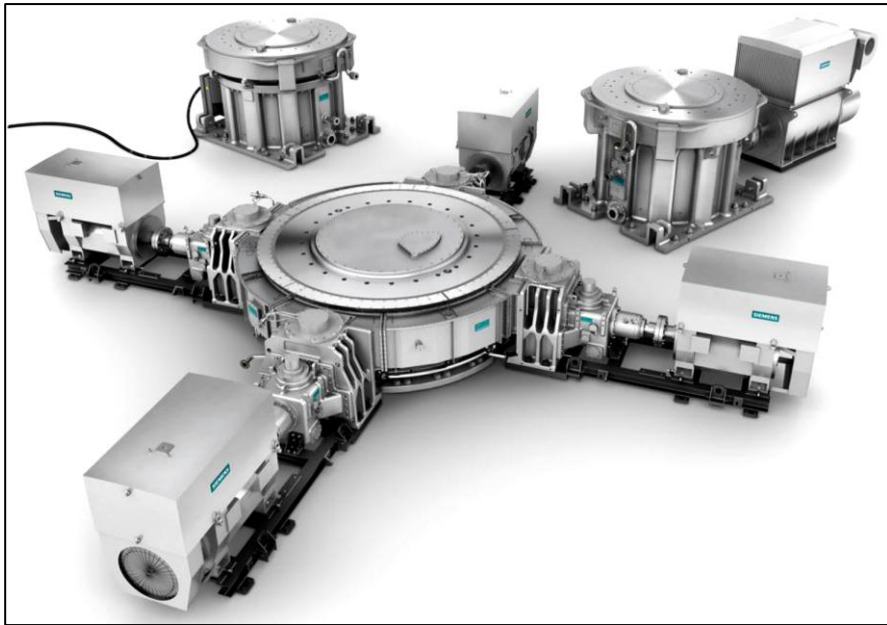

Figure 32: Vertical mill Siemens drives. MultipleDrive in front, KMPP right upper corner, EMPP left upper corner [R-IV].

FLENDER MultipleDrive® is a multi-stage drive. Its components are the following: Gearbox (2 – 6 units); Table thrust bearing; Base frame; Coupling; Oil supply system (for table thrust bearing and gearbox); Piping; Motor; Converter.

The Multiple Drive is commonly driven by two, three, four, five or six autonomous drive units synchronized by a frequency converter. Depending on the equipment, it has a capacity range up to 16.5 MW, with (more or less) no limits to power input. One Multiple Drive unit can be disengaged if service has to be applied, while the other units continue to function and drive the girth gear. This prevents a complete production stoppage and related losses. MultipleDrive has also a lower overall height in comparison with the other drives [Siemens 2013a].

The frequency converter (SINAMICS®) consists of isolation transformer, power electronics, control and cooling systems. It adjusts the speed to suit various product qualities, which optimize the grinding results and achieve energy efficiency. The motor is a squirrel-cage rotor type with a housing made mainly of cast iron [Siemens 2013b; Siemens 2013c].

The general characteristics of the two drive systems can be seen in **Table 7**:

Definition of reference applications – including their system designs

Table 7: General characteristics of KMPP drive and MultipleDrive systems

Drive systems	KMPP	MultipleDrive
<b>Capacity</b>	3 to 8 MW	4 to 16.5 MW
<b>Components</b>	Gearbox Motor Coupling Oil supply system Piping	Gearbox Motors Coupling Converter Oil supply systems Piping
<b>Design</b>	Gear unit (bevel gear stage), 2 planetary stages	Squirrel cage motor, gear unit (bevel gear stage/helical gear stage), grinding plate bearing (girth gear)
<b>Torque</b>	1,300,000 to 3,500,000 Nm	1,200,000 to 8,000,000 Nm
<b>Advantages</b>	Tried and tested (200 references) High power density Standardised components Wear-free	High capacity Variable speed Low overall height Not sensitive to static radial forces Standardised components

The products under study for process industries, application class mining and the operation class fixed / variable speed, are vertical mills, large grinding machines used mainly in cement and building Industry.

The case study (results will be described in section 7.2) should take into account the three alternative products, which are the VM operating with conventional technology, and vertical mill operating with two newly developed technologies, which are named as follows:

- KMPP – Base option: VM operating with KMPP drive
- MD 6 – Alternative 1: VM operating with MultipleDrive 6 MW
- MD 12 –Alternative 2: VM operating with MultipleDrive 12 MW

**Figure 33** shows schematic illustration of three options as VM part and the drive placed under it, consisting of gearbox connected to motors.

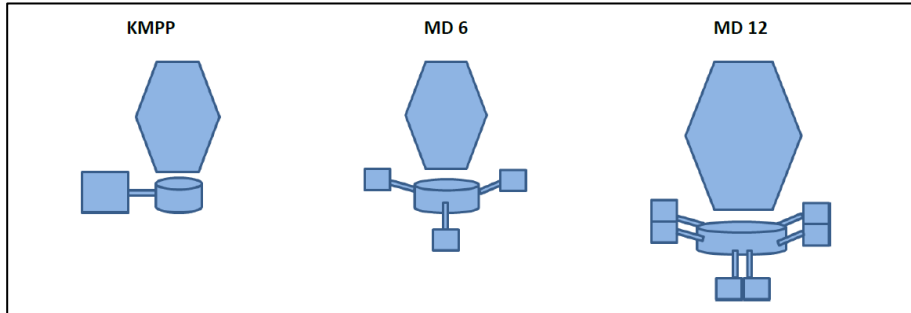

Figure 33: Schematic illustrations of the base option (KMPP) and the two alternative products (MD 6 and MD 12) under study [R-IV].

However, MultipleDrive has not been yet fully tested on field. For this drive Siemens is currently the only provider. So it is of high interest for the company to compare this new technology to the conventional solution in terms of their environmental and economic profiles. This knowledge can be used to help maximize environmental and customer benefits: by informing the end user on which product is environmentally preferable for certain application.

## 6.4 DRIVE-SYSTEM COMPONENTS

As stated in the Introduction, research background, the scope of this project are Drive and Automation Technologies primarily in context to industrial manufacturing as in discreet and process industries. The drives and their use stage were evaluated as a main driver in context to environmental impacts, as well as being economically very relevant, especially in context to the European Ecodesign directive itself [2005/32/EC], [2009/125/EC] respectively, by [COM 2008], [SWD 2012; 90

Definition of reference applications – including their system designs

SWD 2014], [EC 2015a]. Additionally by own case studies: [R-I; R-II; R-III; R-IV] & [JP-I]. [SEC 2011]

**Figure 34** and **Figure 35** schematically show configured drive systems in application context (conveyor belt), one with a motor starter, and the other with a converter. The drive train is connected to a power supply through a circuit breaker, protecting the installation from power overload, followed by a starter or a converter, for start / stop operations and in case of the converter controlling the speed of the motor. The motor is then transferring the electrical energy into mechanical power. This may be followed up by a gear and / or coupling to again vary speed and / or torque or change the direction of the force.

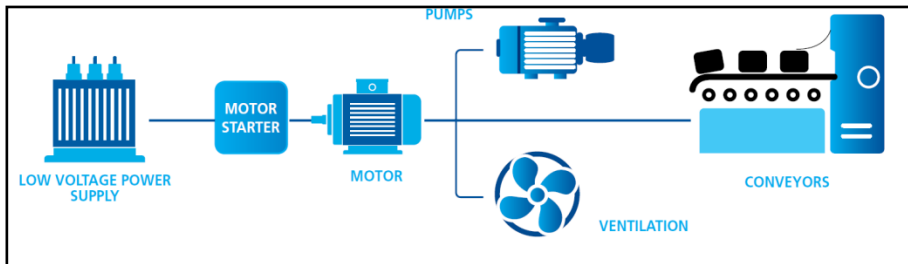

Figure 34: Basic picture of a motor system with a motor starter [CAPIEL 2015]

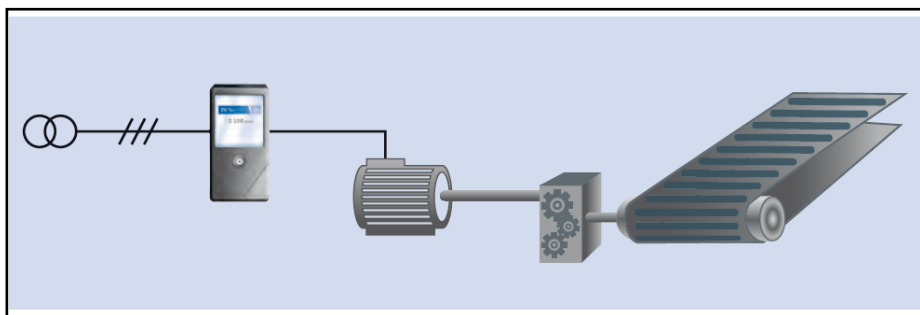

Figure 35: Basic picture of a motor system with variable speed drive [CEMEP 2015]

Further the scope was limited to the IDS portfolio. An overview of the IDS portfolio is shown in **Figure 36** [Siemens 2013e]. The main categories are:

- Motion Control level: PLCs specialised for drive systems in context to motion control;
- Devices for starting / stopping or controlling a motor: Starters (circuit breaker and contactor), softstarters and converters
- Motors: Various devices for the conversion of electrical energy into mechanical power, like for e.g. Alternating Current (AC), Direct Current (DC), low, medium or high voltage (LV, MV, HV),
- Gears and coupling for alternating speed, torque and/or directing of the mechanical source.

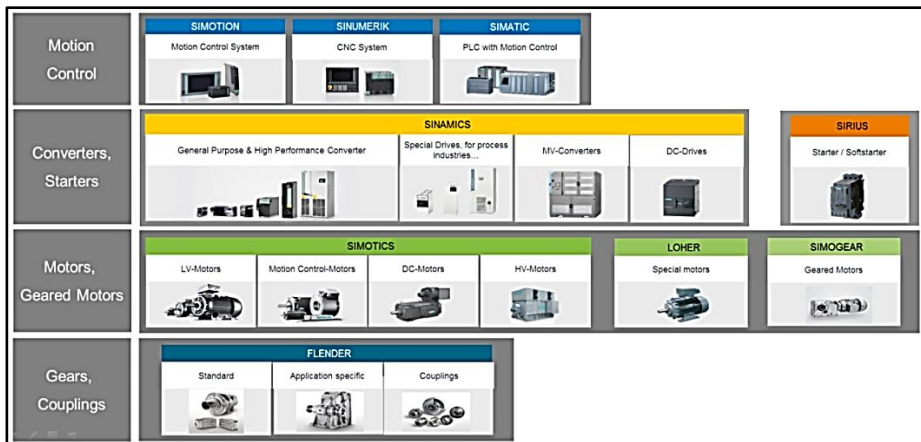

Figure 36: The IDS portfolio, primarily in scope of this research project in context to industrial applications such as conveyor belts, machine tools or pump systems.

These products are relevant because they can all be connected to optimize the performance of the drive system. The main products in context to this study are shown in **Figure 37**. As already mentioned, [CEMEP 2015; CAPIEL 2015], as well as [Volz 2010; EC 2014a; EU 2014; EC 2015a], for instance provided indication concerning the high relevance of the design of the drive system: Where the soft starter only affects the motors consumption when it is started and stopped, a frequency converter can control the motors speed by changing the frequency. This does however influence the motor with a constant power loss from 5% and downwards for 30% load on the frequency converter. Hence, a frequency converter is able to deliver the same functions as a soft starter and further adjust the motor's speed to the exact required power level, but at the cost of a constant energy loss. Thus, it can be important for an entire system's environmental impact to choose the right additional piece of electronic equipment to the motor. This electronic equipment should be selected in accordance with the use phase requirements, and should be either no additional equipment, a soft starter or a frequency converter. This context has been addressed in detail in the case study underlying JP-III. Whereas the highest relevance (environmentally, economically) can be associated with the motors, due to Ecodesign legislation as mentioned above and the internal case studies [R-III; JP-I]. Therefore, it was decided to conduct a detailed LCA case study on component level, exemplarily for motors.



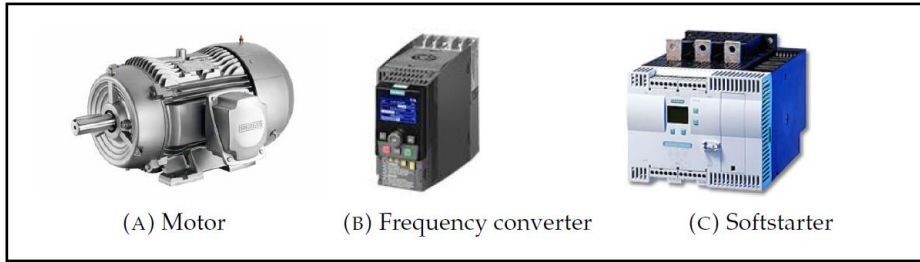

Figure 37: Siemens main products relevant for drive technologies [Siemens 2016b]: Motor, frequency converter and softstarter.

## 7 “CLASSIC” ECO-DESIGN IN CONTEXT TO THE REFERENCE APPLICATIONS

### 7.1 GENERAL

“Classic” ecodesign case studies in this context means, evaluating environmental hotspots on component or system level. However, in context to this research project, the ones picked on system level were set up already in a comparative view, comparing different systems (e.g. ancestor and predecessor systems, or alternative solutions), in combination with LCC, and took account of applications. Further details will be described in the corresponding sections.

### 7.2 INDIVIDUAL SECTION MACHINES

#### 7.2.1 GOAL, SCOPE & LIFE CYCLE INVENTORY

This summary is based on [JP-I]. The goal of the case study was basically to identify a) the most relevant life cycle stage of the system relating to the environment and the economics and b) the components and environmental impact categories with the highest contributions to the entire system. Additionally, the results were then to be c) broken down to one glass container produced on “System A” and on “System B”, respectively. By comparing the previous solution with the innovated one, the expected benefits of the servo drive solution were to be quantitatively evaluated based on the results of the LCA. To achieve this, the perspective of a system refurbishment was taken, which means that the servo drive components were considered as addition to an identical background system (i.e. the

manufacturing peripherals), which was identical for the two systems. Since the detailed LCA accounted the modernized IDS components and electric drives in addition to the background system, i.e. as extra burden, vs. the potential benefits resulting from their use, the described comparison can be considered as a worst-case scenario. In real life, the basis for the comparison would be two different systems – the individual section machine, based mainly on pneumatic drive technology and the individual servo section machine, utilizing electric servo drive technology, offered by the original equipment manufacturer (OEM). In the case that the increased performance offsets the additional economic and ecological impact, then it could make sense to upgrade existing machines with servo drive components. This is summarized in **Table 8**.

The functional unit for the study was defined as manufacturing a defined number of glass containers in a certain period on a combined system. The number of glass containers manufactured over the system lifetime is 2.88 billion (2.88E+09), based on a throughput of 400 bottles per minute for the servo drive system, by operating 6,000 hours per annum for 20 years.

The system boundaries for the servo drive components were set according to [EN50598-3:2015], corresponding to a cradle-to-grave approach, including the extraction of resources, the manufacturing of the components, their assembly, the use stage (being the production of glass containers) and the final end-of-life stage incl. recycling and disposal.

“Classic” eco-design in context to the reference applications

Table 8: Overview of the components. Cells with a grey background are included in the scope of the LCA, whereas the disregarded background system is similar in systems A and B.

<b>Scope of LCA</b>	<b>System A</b>	<b>System B</b>
<b>Manufacturing/construction stage</b>	Not considered; no data available	Servo drive components: PLC; frequency converters; servomotors
<b>Use stage</b>	Measurements: Performance data from OEM	Measurements: Performance data from OEM
<b>End-of-life stage</b>	Not considered; no data available	Approximated, based on detailed assessment of key components

The life cycle inventory is the basis for the life cycle impact assessment (LCIA) [ISO 14044:2006]. The servo drive components were modelled based on existing Siemens data and aggregated GABI data sets, e.g. for assembly energy, metals and other commodities/materials. The various components from the five function groups, as shown in Table 6, were clustered into two the clusters electronic devices (VSDs, MC, ACC) and electromechanical devices (motors, S&CG) and handled as laid out in [Herrmann et al., 2012]. The material composition within the two clusters is more or less the same. The electromechanical components predominantly comprise high-grade metals and plastics, and the electronic devices comprise electronic parts that are soldered on printed circuit boards and accommodated in a plastic housing. As already mentioned above, the basis for the assessment of the use stage was data provided by the OEM supplying the modernized IS machine (System B, IS machine

with servo drive components), which state a 40 % increase in energy efficiency and a 15 % increase in machine availability [Siemens 2015a]. To assess the energy consumption of the drive trains in the use stage, the SIZER engineering tool [SIZER 2015] was used to model the corresponding profile in operation. The efficiency of the servomotors was conservatively set to 90 %. The energy consumption of System A was then determined to be 140 % of the calculated consumption of System B. The potential environmental impact of the two systems was then calculated using EU27 power mix.

In the impact assessment, the following impact categories from the CML2001 characterization model of April 2013 as implemented in GABI, were evaluated in detail:

- Eutrophication potential (EP),
- Photochemical ozone creation potential (POCP),
- Global warming potential (GWP) and
- Acidification potential (AP).

The characterization model was chosen due to the fact that data for some of the servo drive components had already been assessed based on this CML model, and in order to aggregate the scores meaningfully, the characterization models have to match. The categories were chosen since they are strongly related to electricity production, since power consumption is known to be a major driver when it comes to the environmental impact of the type of equipment under consideration.

## 7.2.2 RESULTS

### 7.2.2.1 LIFE CYCLE IMPACT ASSESSMENT

The life cycle impact assessment (LCIA) was performed for each key component corresponding to the LCA approach described in the previous chapter.

**Table 9** summarizes the results of the LCIA of the materials and manufacturing stage – quantifying eutrophication potential (EP), photochemical oxidation potential (PCOP), acidification potential (AP) and global warming potential (GWP) – for each function group cluster, while

Table 10 lists the function groups’ potential impacts related to their amount in the system, using the components’ weight (within the function group) to build the relation.

Table 9: LCIA scores in the chosen impact categories for the manufacturing stage aggregated for each function group.

<i>Impact category</i>	<i>Motors</i>	<i>VSDs</i>	<i>MC</i>	<i>ACC</i>	<i>S&amp;CG</i>	<i>Total</i>
EP [kg PO4- Eqv.]	6.19E+01	4.10E+00	1.55E+00	7.70E-01	4.00E-01	6.87E+01
PCOP [kg C2H4- Eqv.]	8.24E+01	5.81E+00	1.35E+00	7.50E-01	3.90E-01	9.07E+01
AP [kg SO2- Eqv.]	8.18E+02	7.91E+01	2.07E+01	1.29E+01	6.75E+00	9.38E+02
GWP [kg CO <sub>2</sub> - eqv.]	1.92E+05	1.21E+04	3.15E+03	1.56E+03	8.17E+02	2.09E+05

Table 10: Normalized LCIA scores for the manufacturing stage using the component weight per function group as normalisation factor.

<i>Impact category</i>	<i>Motors</i>	<i>VSDs</i>	<i>MC</i>	<i>ACC</i>	<i>S&amp;CG</i>	<i>Total</i>
<i>Weight [kg]</i>	1,385	672	56	49	22	2,184
EP [kg PO4-Eqv. / kg mass]	4.47E-02	6.10E-03	2.77E-02	1.57E-02	1.82E-02	3.15E-02
PCOP [kg C2H4-Eqv. / kg mass]	5.95E-02	8.65E-03	2.41E-02	1.53E-02	1.77E-02	4.15E-02
AP [kg SO <sub>2</sub> -Eqv./ kg mass]	5.91E-01	1.18E-01	3.70E-01	2.64E-01	3.07E-01	4.29E-01
GWP [kg CO <sub>2</sub> -Eqv. / kg mass]	1.38E+02	1.80E+01	5.62E+01	3.19E+01	3.71E+01	9.58E+01

The contribution of the function groups to each impact category is more or less comparable, but it also shows that the motion control functionality has relatively high LCIA scores related to its weight.

With reference to the GWP, motors made up the largest part of all components with 1.92E+05 kg CO<sub>2</sub>-eqv., which represents 92 % for the manufacturing stage (2.09E+05 kg CO<sub>2</sub>-eqv. in total). Frequency converters with 1.21E+04 kg CO<sub>2</sub>-eqv. represented the second highest contribution to the GWP. Evaluating the impacts broken down according to the weight of

“Classic” eco-design in context to the reference applications

the components verifies the significance of the motors (or the drive system) in the system context.

To put the result into a broader perspective and to allow a comparison across impact categories, external normalisation factors for the EU (25+3) from [Sleeswijk et al., 2007] were applied. The results are shown in **Figure 38**.

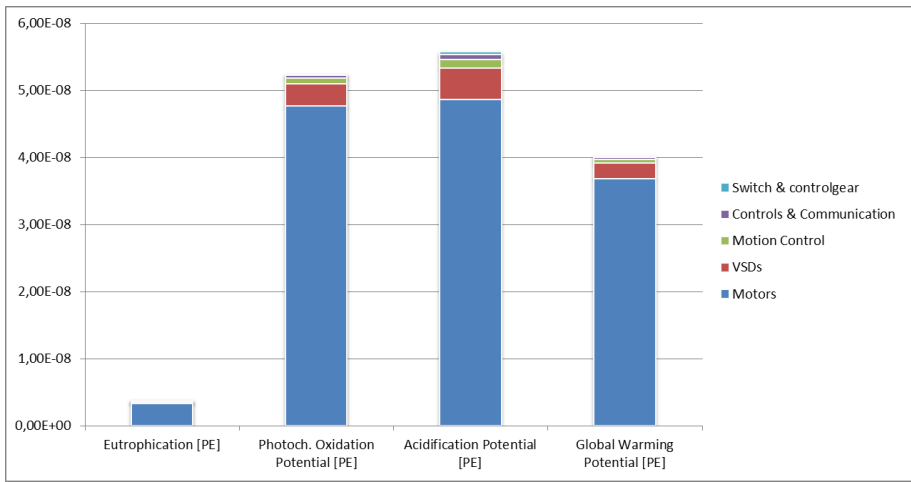

Figure 38: Normalised LCIA Scores of the components of the drive system for IS machines.

Looking at the evaluated impact categories, AP, POCP and GWP are the most relevant impact categories with a similar order of magnitude because they have the highest share of the overall contribution. For a better overview and due to interdependencies between the four impact categories (e.g. all energy-related), results are shown and described in the following in terms of the GWP as leading indicator and are representative for the discussion on the environmental aspects of the combined system. The results of the remaining environmental impact categories



supported the statement that motors – respectively the drive system – have the highest environmental impact of the overall system.

For the assessment of the use stage, the power consumption of all components was screened (i.e. calculated, and not measured) and put in context with the application scenario. The power consumption of 256 components out of 632 was analysed. Cables and memory cards were excluded along with the power consumption of the drive system, which was separately analysed in detail. The analysis indicated a mean power consumption of 6 Watts per hour for each component, estimated based on the data obtained from data sheets. This then leads to total power consumption of 10,000 kWh/y for controls, communication and the other automation components. SIZER was now used to model the application and the corresponding power consumption (including losses) for the drive systems in total, based on the parameters mentioned above. A power consumption of about 534,600 kWh/y was obtained. The values were added leading to the total system power consumption of 544,600 kWh/y, while the drive systems account for about 98 % of the power consumption. By using the EU27 power mix dataset (GABI data), this power consumption corresponds to a GWP of 5.17E+06 kg CO<sub>2</sub>-eqv. over the 20 years of service life. Additionally, in terms of maintenance, it is assumed that at least the motors would have to be replaced once within the service life of the system, which leads to a total of 5.37E+06 kg CO<sub>2</sub>-eqv. for the use stage.

The end-of-life stage was assessed in detail for all relevant components, but not considered in the system context because of low significance in the selected impact categories and very few

“Classic” eco-design in context to the reference applications

options for the component manufacturer to influence it. Expectable benefits from end-of-life have not been considered, due to their relatively low size.

Based on the LCAs of various components used to modernize a glass container manufacturing system, it can be seen that the use stage is by far the most significant life cycle stage in terms of the potential environmental impact. This is due to the drive systems and their energy consumption during use. In terms of absolute GWP numbers, the optimization of the manufacturing system through improved automation, motion control and servo drives, accounts for about  $2.09\text{E}+05$  kg CO<sub>2</sub>-eqv., leading to a reduction of  $1.86\text{E}+06$  kg CO<sub>2</sub>-eqv., which represents a reduction of about 26 %. In total, neglecting the potential benefit as a result of the end-of-life treatment of -0.3 %, it can be stated that the manufacturing stage of the servo drive components accounts for about 4 % and usage for about 96 % of the total GWP.

From a different perspective, the higher energy efficiency and the productivity (performance) that were achieved by modernizing the system, result in the GWP of the final glass container being reduced by approximately 40 %. The ecological payoff period was calculated to be two years, as about 100 tons of CO<sub>2</sub>-eqv. are saved per year as a result of the modernization, accounting for 200 tons of CO<sub>2</sub>-eqv. in manufacturing.

#### 7.2.2.2 LIFE CYCLE COSTING

For the LCC, costs were derived using a cost breakdown structure, the results of which are summarized in **Table 11**. It has to be mentioned in this context that in terms of the LCC of the case study, the view taken was that of modernizing an existing system, not directly comparing two alternative options involving

“greenfield” plants. The objective was to evaluate the economic benefits in terms of a refurbishment. In the context of “greenfield”, solutions including servo drives are expected to be favourable even with regard to environmental and financial aspects. In addition to the energy costs as well as the investment costs for servo drive components, which were needed for modernization, all other costs were estimated based on experience. The peripherals were omitted from the calculation, assuming that they would be kept in the case of a system modernization or refurbishment. End-of-life treatment was not considered either since component manufacturers could hardly influence the situation in this stage – and therefore no robust data is available. Further, it is assumed that there is no significant difference between the systems, and usually the disassembly and end-of-life treatment has a positive financial impact due to the high quality of materials used in such a system.

“Classic” eco-design in context to the reference applications

Table 11: Summarized cost allocation derived from a cost breakdown structure for life cycle costing

Cost allocation	System A: <i>IS with pneumatic / hydraulic actuators</i>		System B: <i>IS with IDS components</i>	
	Parameter [k€]	Remark	Parameter [k€]	Remark
Machines	100	Exchange of pneumatic / hydraulic actuators	300	Exchange of pneumatic / hydraulic actuators with servo motors
Installation	10	once per service life, 10 % of Investment	30	once per service life, 10 % of investment
Maintenance	40	20 k€ / a	20	10 k€ / a
Spare parts	50	Exchange of pneumatic cylinders	100	Exchange of motors
Energy (electric power, kWh)	1,800	1.50E+07 kWh * 0.12 €/kWh	1,284	1.07E+07 kWh * 0.12 €/kWh
Total	2,360		1,910	

The basic principle for estimating the life cycle costs was that the costs for pneumatic components are about one third of those for the electronic components, but maintenance is usually higher in a manufacturing system dominated by pneumatic and hydraulic actuators. In the study, maintenance costs for System A were assumed to be double of those for System B. In order to make a proper comparison with the servo drive system, regarding the installation, it was assumed for the pneumatically driven system that at least the actuators would have to be replaced by servo drive components when modernizing. For an operating time of 20 years, it was assumed that at least some components, e.g. the motors and the pneumatic actuators, would

have to be exchanged after 10 years of operation. The ZVEI LCC analysis tool [ZVEI 2011] was populated based on the CBS and depreciation for the investment (10 % of the investment for 10 years) was taken into account.

Based on this LCC, the modernized System B performs about 19 % better than the previous system, resulting in savings of about 450,000 € over 20 years of lifetime. Taking the cash value of the energy costs into account, System B outperformed system A by 29 %. The payback time for the modernization was calculated to be around 5.34 years.

#### 7.2.2.3 ECO-CARE-MATRIX

The ECM for the two systems in **Figure 39** shows the environmental and economic improvements of the system when using servo drive components. The reference, System A, located at the centre of the matrix, is responsible for energy costs of more than 1.5 million € and the discharge of more than 7,243 tons CO<sub>2</sub>-eqv. over the operating time of 20 years. The benefit of the enhanced system with servo drive components (System B), is represented by scenario 1. Concerning environmental benefits in terms of GWP, the introduction of motion control and servo drives lead to an “improvement” of about 26 % (a reduction of about 1.9 million kg CO<sub>2</sub>-eqv. in absolute terms), while the customer benefit increases by 19 % (just taking into account the cost savings).

“Classic” eco-design in context to the reference applications



Figure 39: ECM of the comparative assessment of the two drive systems for IS machines.

Linking these results to the output of the manufacturing system, the carbon footprint of the container glass bottles produced on System B is reduced by about 40 % compared to System A.

### 7.2.3 DISCUSSION & CONCLUSION

It first has to be repeated that this comparative part of the case study was carried out in an application-specific context (i.e. a specific technology) and in a European setting. The results will be different depending on the particular region and application – and will especially depend on the power grid mix and the associated environmental impact. On the application side, in a less dynamic production flow, i.e. one with longer holding intervals, the differences between pneumatic and servo solutions can be expected to be less, as [Hirzel et al., 2014] pointed out when comparing pneumatic to electric actuators.

In terms of the financial benefits of the investment regarding modernization, it has to be emphasized that some parameters in the study were estimated based on the assumption that the manufacturing peripherals were identical. For instance, instead of modernizing a manufacturing system (one of the scenarios in this case study), if a completely new manufacturing system without compressed air is built, all of the auxiliary equipment required to provide compressed air can be reduced. This results in even higher savings. On the other hand, if there is a very effective compressed air system in place and different process settings, savings might be lower and the payback time for the investment will be longer. Additionally, the economic framework of the company will significantly influence the payback time of the investment, for instance individual interest rates, depreciation practices and discounts negotiated for the investment, etc. Finally, the current and future market situation will also have an impact here, especially how electricity prices and inflation rates will develop. Hence, it can be said that the LCC approach was too generalized to obtain an impression about

investing in a refurbishment, because in reality, the specific financial pay-off will depend on the very individual situation of the particular company.

The results of the environmental performance evaluation based on life cycle assessment clearly showed the high significance of the use stage. Therefore, the chosen power mix and levers for increasing energy efficiency have a high influence on the potential environmental impact. In the current European average power mix, coal, oil, and natural gas still play a big role as primary energy sources and contribute to global warming, acidification and eutrophication being the most relevant impact categories. This will change due to an increasing share of renewables providing electric power and consequently declining climate relevant emissions from the power mix. Hence, other indicators/impact categories might be more relevant in the future, as well as other aspects of ecodesign (besides energy efficiency) tackling these impacts. Therefore, more impact categories than the energy-related ones used in this study should be taken into account in further studies, like for instance resource depletion and toxicity. In that context it has to be mentioned too that the results should then also be validated by applying different characterization models in order to take latest scientific developments into account, e.g. within toxicity-related impact categories.

The performance evaluation, as key parameter for the above-mentioned results, has been carried out by the system provider and was based on measurements in a defined application set-up, coming to an average in energy savings of 40 % when comparing the two systems. There was no detailed data available



concerning the individual process steps and the associated operations. Therefore, the results shouldn't be transferred to any other, principally comparable manufacturing system or generally on the discussion of efficiency of pneumatic vs electric drives. In this context it has to be assumed that the relevant parameters, e.g. cycle time and power demand, may have been favourable for electric drives, but again these aspects were not in the scope of this case study.

The analysis of the complete modernized manufacturing system for container glass bottle production showed that the largest contribution to the environmental impact and to the economic costs is related to the energy requirements during the use stage. As a consequence, the highest opportunities for reducing potential environmental impact and costs, can be realized by upgrading the system to include motion control and servo drives. The underlying LCA of the manufacturing system itself was a rather extensive case study, taking into account more than 600 components, enabling to allocate the environmental impacts, as well as the benefits to certain functionalities of the system. It can be concluded that any intelligence (controls, communication) which may be added into a comparable manufacturing system, that improves (energy) efficiency and throughput, will pay off in terms of cost savings and the reduction of (potential) environmental impact. In terms of the cost-benefit evaluation, it can be concluded that even a refurbishment of an existing system can be a viable option for improving performance.

For companies using LCA to support ecodesign and to support sustainability messages, the key recommendation from this case study is to (i) adapt the methodology to the system perspective and to (ii) to map the applications in this context. For instance,

“Classic” eco-design in context to the reference applications

the enhancement of system engineering tools with relevant environmental indicators would be an option to promote ecodesign on a larger scale than just providing data for up to 30 different environmental impact categories, as is the case in some environmental product declarations.

## 7.3 VERTICAL MILLS

### 7.3.1 GOAL, SCOPE & LIFE CYCLE INVENTORY

The following summary is drawn from [R-IV], so further details to the case study can be found in the annex. The goal of this study was to compare environmental performance of the conventional technology, vertical mill with KMPP drive at 6MW, with two alternative solutions: vertical mill with MultipleDrive of 6 MW capacity and vertical mill with MultipleDrive of 12 MW capacity, as introduced in section 6.3.

First, through performance of LCA on three products, environmental hotspots had to be identified and the environmental performance of two alternatives compared with the base option for the same functional unit. Moreover, economic aspects are also considered from a customers’ point of view (customer benefit). Thus, LCC will be applied to products under study at the same functional unit, as defined in LCA. The results from LCA and LCC were combined and visualised through the Eco Care Matrix tool. So finally, based on the analysis of the study results, recommendations to the company were generated.

The functional unit (FU), which is a reference unit for products quantified performance, is defined here as a total production of KMPP, a conventional drive technology, during its life time

(20 years), on normal operating conditions with 6 MW power – “Grinding of 25185000 tonnes of clinker from thickness of 30 mm to very fine under normal operating conditions”. Since the operation time of KMPP and MD differs, taking into account the fact that MD has no downtime, time is a key parameter. The normal operating conditions for each alternative are given in **Table 12**.

Table 12: Operating conditions of the systems under study corresponding to the functional unit.

	KMPP	MD 6	MD 12
Daily operation [hr]	23	24	24
Power [MW]	6	6	12
Production rate [tn/hr]	150	150	300
Life time [yr]	20	20	20
Production in lifetime [tonnes]	25185000	26280000	52560000
Scaling factor to FU	1	0.95	0.48

The system boundaries of the LCA were defined to include all the direct inputs and outputs from the extraction of resources to disposal and recycling in the so-called “Cradle to Grave” perspective. **Figure 40** shows the approach by the means of a flow diagram. All the activities, such as building of the plant, infrastructure, production equipment etc., which do not relate directly to the product, are not considered. Indirect inputs such as transportation to manufacturing factories, customer and recycling facilities are included.

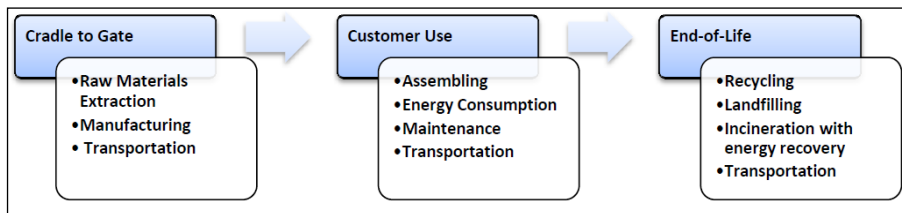

Figure 40: Flow diagram of life cycle stages of the model [R-IV].

The results were obtained using GaBi software and ReCiPe 1.08 Methodology are presented here, using characterized and normalized midpoint impact scores for the selected impact categories. The normalized impact scores are defined as an average European citizen. The impact scores are also presented as the three Areas of Protection: Human Health, Ecosystems and Resources, which are aggregated normalized endpoint results. Finally, results using a Single score are shown, where the three Areas of Protection are aggregated using average weighting factors, recommended by ReCiPe.

It is important to note that during the assessment, a weighting factor of one is applied for normalized midpoint scores, in order to compare results across impact categories. This means, that during this assessment all the categories are considered equally important.

The production stage covers all the processes connected to raw materials and energy acquisition and transformation into a product, from cradle to gate. The manufacturing stage was build up in GaBi, using DfX feature, as a GaBi product model. This BoM included all the materials, weights and manufacturing processes for all the parts of the product. Most of the data for the BoM is internal data provided by Siemens. In addition, logical assumptions were made and generic data or data from similar products was used. Materials and processes in the BoM are then assigned to materials and processes from GaBi database. For each part a GaBi data set of semi-finished product (e.g. steel billet or steel sheet) is taken, instead of raw material, which aggregates all the environmental impacts of manufacturing until this stage. Afterwards, additional manufacturing processes are

added (e.g. steel turning or steel grinding) based on part type, size and material. Average German data was used for modelling.

The use stage plan included the energy consumption of the product during its operation at the customer, maintenance, transportation to the customer's site and assembly of the product. The energy demand was calculated based on the generated motor power multiplied with average operation time needed to fulfil the functional unit. Electrical losses of 1 % were assumed. The EU-27 power mix GaBi process was used for the electricity. For maintenance, manufacturing 1 % of medium and small parts and electricity needed for production is added. Spare parts were also considered.

The EoL stage is also modelled as separate GaBi plan and linked to the product model. The plan is based on product's material composition defined in the product model. All the materials were classified for the EoL following the [VDA 231-106:1997] classification as available in GaBi. The plan defines different recycling and disposal options for each material group after the disassembling process. The default treatment options are defined as follows:

- Ferrous metals (steel): Recycling
- Non-ferrous metals (aluminium, copper): Recycling
- Fraction with high heating value (paper, plastics): Thermal treatment with energy recovery
- Other (or not recycled/recovered fraction): Landfill

For electronic scrap material separation and recycling a default scenario was set. Average European data is used for modelling.

Transportation was considered in each stage: transportation of the raw materials and semi-finished parts to manufacturing factories, transportation of the final product (not assembled) to the customer and finally transportation of separated materials to the landfill and recycling/energy recovering facilities. When the transportation was not aggregated in the GaBi process, transportation with truck and container ship at average distances, logically assumed, were added to the model.

### 7.3.2 RESULTS

#### 7.3.2.1 LIFE CYCLE IMPACT ASSESSMENT

First, a hotspot analysis of the three product drives production stage is presented, to indicate product improvement potentials. For this analysis, only drives are considered, without including the mill. After that, a hotspot analysis (including the mill) of the whole life cycle was made; followed by a comparative analysis of the base option and the two alternatives.

The results were calculated by software for mentioned environmental impact categories by multiplying the individual inventory data with specific characterization factors from ReCiPe. The results are presented at characterised and normalised midpoint and endpoint. A midpoint indicator is a parameter in a cause-effect chain (of environmental mechanism) for a particular impact category that is between the inventory data and the category endpoints [Bare et al., 2000]. The results of individual characterised midpoint impact category are expressed as equivalent values (e.g. kg CO<sub>2</sub>-eqv. for GWP) and of endpoint impact categories as damage values (e.g. species per year for Climate change ecosystems). The normalised impact scores were expressed as person equivalent (PE), which represent an average

European citizen. The endpoint indicators are argued to have higher relevance but lower certainty compared to midpoint. On the other hand, midpoint indicators are considered to have lower uncertainty, but are generally believed to be more difficult to communicate to decision makers [Bare et al., 2000]. Therefore, both midpoint and endpoint results were evaluated. To make the results comparable across different impact categories, the impact categories are normalized to the same units and a weighting factor of one is applied. The endpoint results are aggregated into three areas of protection: Human Health, Ecosystems and Resources and average weighting recommended by ReCiPe is applied.

Initially, the production stage of the KMPP drive system and the impacts of each of the components is shown in **Figure 41**.

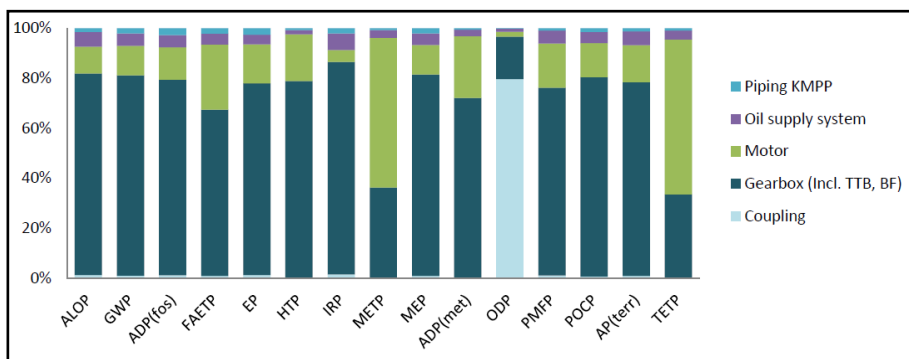

Figure 41: Midpoint impact scores scaled to 100% for each component of the KMPP drive system, including only production stage [R-IV].

It shows, that the gearbox has the highest share of most impact categories (except for ODP, METP and TETP). This is due to the fact that the gearbox has the highest weight, almost 20 times higher than e.g. the oil supply system. In marine and terrestrial ecotoxicity (METP and TETP), the motor appears to have the

worst environmental performance, which can be explained by the big amount of copper. Coupling has the highest impact score in ODP, which can be explained by the material composition of the elastic ring (polytetrafluoroethylene); the environmental impacts in the rest of the categories are rather small. Piping and oil supply system have a better environmental performance in all categories, due to smaller size while similar material composition compared to other parts.

Now **Figure 42** shows the results for the MultipleDrive6 drive system from the production stage of the different components. It is observed from the results that TTB has the highest impact scores in most categories (except for METP, TETP and ODP), since it is the largest component of the drive, followed by motor and converter. The motor and coupling components present similar results as for KMPP. The base frame, piping and oil supply systems have lower contribution to the environmental impacts in most categories.

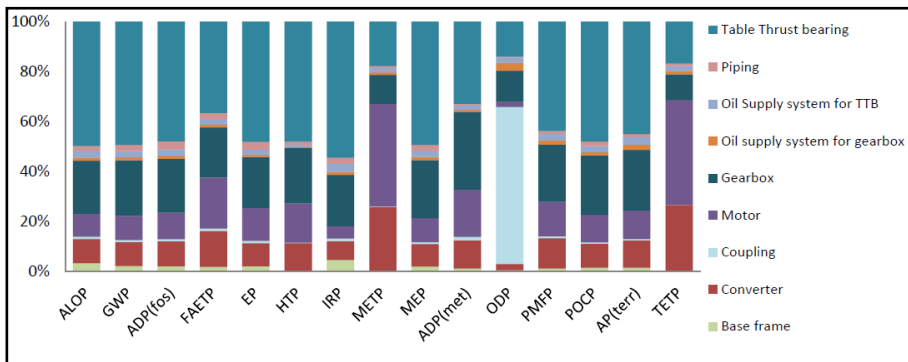

Figure 42: Midpoint impact scores scaled to 100% for each component of MultipleDrive 6, including only production stage [R-IV].



The converter appears to have similar impacts to motor in most categories except for FAETP, METP, TETP, and ADP(met), where motor has a higher share.

By **Figure 43**, showing the total LCIA score over all life cycle stage exemplarily for the KMPP, results similar for the MultipleDrive, in the respective impact category, it can be determined that the use stage is dominant for more than 90% in all impact categories, except for ADP(met), where production stage has the highest share. This is explained by the high electricity consumption that takes place during use stage. For the production stage, high impact in metal depletion occurs due to raw material extraction, where the production of the mill has a higher share than the production of the drive.

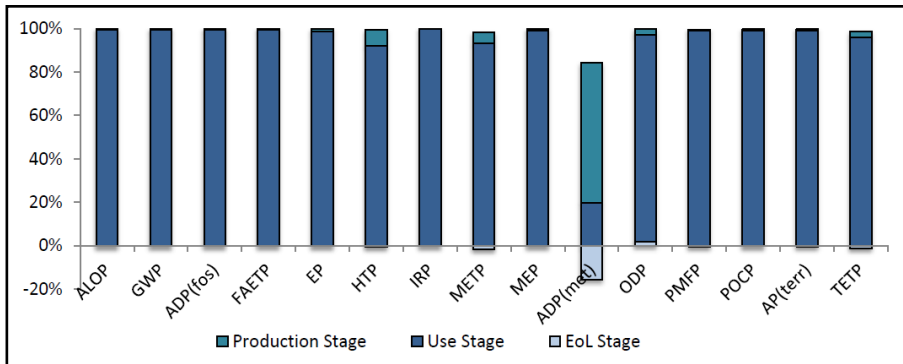

Figure 43: Midpoint impact scores scaled to 100% for KMPP, including all life cycle stages [R-IV].

The results from the comparative analysis of the base option to the two alternatives are presented in **Table 13**, where characterized midpoint impact scores and calculated relative change of the alternatives to the base option are shown.

“Classic” eco-design in context to the reference applications

Table 13: Characterized midpoint impact scores including all life cycle stages of the three products and the relative change of the alternatives to the base option.

Impact Category	Abbr.	Units	KMPP	MD 6	MD 12	(RC%) MD 6 to KMPP	(RC%) MD 12 to KMPP
Agricultural land occupation	ALOP	[m2a]	4.21E+06	4.03E+06	4.02E+06	-4.4%	-4.4%
Climate change	GWP	[kg CO <sub>2</sub> -Equiv.]	4.79E+08	4.58E+08	4.58E+08	-4.4%	-4.5%
Fossil depletion	ADP(fos)	[kg oil eq]	1.29E+08	1.23E+08	1.23E+08	-4.4%	-4.5%
Freshwater ecotoxicity	FAETP	[kg 1,4-DB eq]	1.86E+05	1.78E+05	1.77E+05	-4.4%	-4.5%
Freshwater eutrophication	EP	[kg P eq]	3.12E+02	2.98E+02	2.97E+02	-4.4%	-4.6%
Human toxicity	HTP	[kg 1,4-DB eq]	1.29E+07	1.24E+07	1.21E+07	-4.3%	-6.1%
Ionising radiation	IRP	[kg U235 eq]	1.16E+09	1.11E+09	1.11E+09	-4.4%	-4.4%
Marine ecotoxicity	METP	[kg 1,4-DB eq]	9.75E+04	9.34E+04	9.25E+04	-4.2%	-5.1%
Marine eutrophication	MEP	[kg N-Equiv.]	5.28E+04	5.05E+04	5.04E+04	-4.4%	-4.5%
Metal depletion	ADP(met)	[kg Fe eq]	7.91E+06	7.82E+06	6.35E+06	-1.2%	-19.6%
Ozone depletion	ODP	[kg CFC-11 eq]	3.43E-01	3.29E-01	3.24E-01	-4.3%	-5.5%
Particulate matter formation	PMFP	[kg PM10 eq]	5.40E+05	5.16E+05	5.15E+05	-4.4%	-4.5%
Photochemical oxidant formation	POCP	[kg NMVOC]	9.58E+05	9.16E+05	9.14E+05	-4.4%	-4.5%
Terrestrial acidification	AP(terr)	[kg SO <sub>2</sub> eq]	1.92E+06	1.83E+06	1.83E+06	-4.4%	-4.5%
Terrestrial ecotoxicity	TETP	[kg 1,4-DB eq]	8.67E+03	8.30E+03	8.26E+03	-4.3%	-4.7%

It can be seen from the results that KMPP performs worse in all the categories, both compared to MD 6 and to MD 12. It is also noticeable that in all of the categories, except for Metal depletion, the difference is around 4.5%. That can be explained by the fact that use stage is dominant stage in most of the categories and MD 6 and MD 12 consume 5 % less energy due to variable speed drive efficiency.

For a better understanding of the 4.5% difference between KMPP and the two alternatives (MD 6 and MD 12), the amount of kg CO<sub>2</sub>-eqv. saved (from the category Climate Change) is calculated. The results are shown in Table 4, and it is seen that the amount saved in MD 6 and MD 12 is approx. 10 times higher than the kg CO<sub>2</sub>-eqv. emitted during production stage (i.e. 20,163,670 kg of CO<sub>2</sub>-eqv. saved compared to 2,646,060 kg of CO<sub>2</sub>-eqv. from production stage in MD 6 alternative).

In Metal depletion category, the difference of MD 6 and KMPP is relatively small, while for KMPP and MD 12 is almost 20 %. That is due to the fact that even though MD 12 is bigger than KMPP, for the same FU different scaling factors are applied. To produce the same amount of clinker the comparison of KMPP to MD 12 is almost 2 to 1, due to higher production rate of MD 12.

Characterised results have different units per impact category, thus cannot be directly compared either identified as more relevant. Therefore, normalised results are used, derived via normalisation factors provided by the ReCiPe impact assessment method referring to the year 2000 and the territorial unit EU25+3 [Wegener Sleeswijk et al., 2008]. In **Figure 44**, the normalised results are shown, and it can be seen that for most categories the difference between base option and both alternatives is rather small, where KMPP has the highest scores. Consequently, KMPP has worse environmental performance. The impact category that has the highest score is IRP, followed by ADP(fos), as they are the most affected by electricity consumption which is high during use stage.

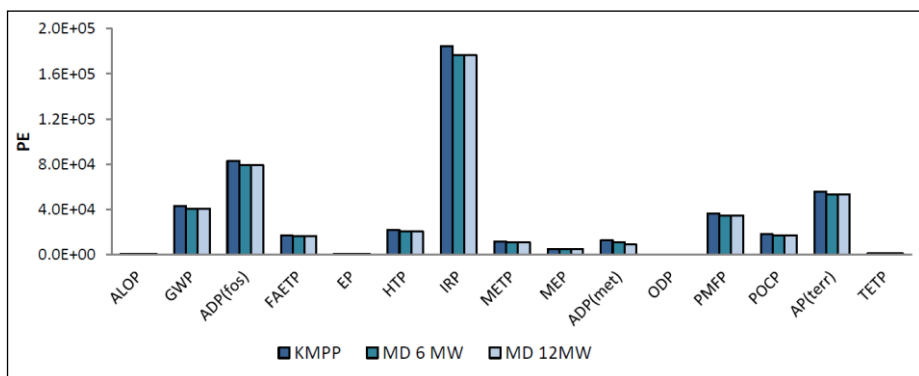

Figure 44: Normalized midpoint impact scores of the three products for the whole life cycle [R-IV].

“Classic” eco-design in context to the reference applications

Now the results are shown in characterized Areas of Protection, where the production, use and EoL stage are shown for each of the options (**Figure 45 A, B & C**). Next, the impact scores are normalised and average weighting is applied. The impact scores are then aggregated to a single score (**Figure 45 D**).

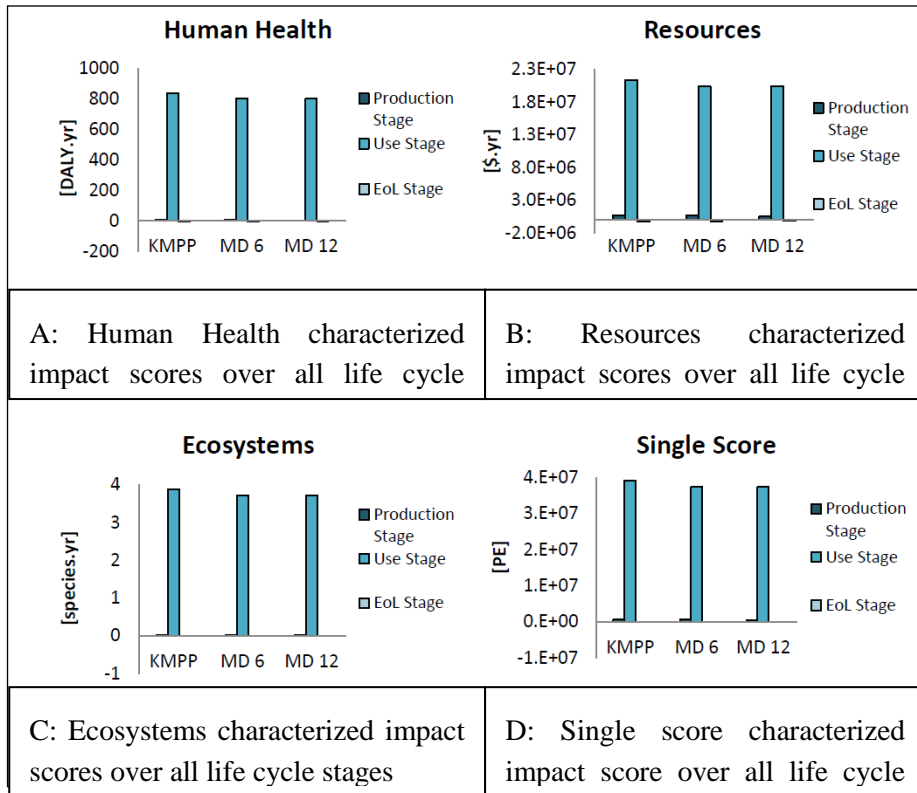

Figure 45: Impact scores characterized in Areas of Protection (A, B, C) and Single Score (D) [R-IV]

In general, KMPP appears to have the worst environmental performance. Although the difference is rather small, it is comparable to the total impact from the production stage. Therefore, it is considered significant.

### 7.3.2.2 LIFE CYCLE COSTING

The results of the LCC on three products under study are given here at present value costs. First, distribution of the costs in time is analysed. After that, the choice of inflation and interest rates is explained. Then, costs are given for each cost element, followed by comparison of total costs.

It is important to consider when in time the costs are expected to occur. The first year is the year when the product is acquired by the customer and includes the product's price and installation cost. The same year the use of the product starts, meaning that the operation and maintenance costs occur until the end of the operating time. The operation profile of each product is estimated as the time needed for the product to fulfil the FU (production of 25185000 tonnes of grinded clinker). As mentioned before the operation profiles are different for three options. The cost of purchasing a spare motor is assumed to take place after 10 years, when a need for the motor replacement is estimated. After the end of operation, the EoL costs are approximated as a rest value of the product (in case the operation time is less than life time of the product) or as a credit generated from the recycling. All the costs are assumed to take place in the end of the year. The choice of interest and inflation rates is critical for the results of the analysis. A high inflation rate makes costs that occur in the distant future more expensive, benefitting the option with lower future costs. On the other hand, a high interest rate favours the option with the lowest investment cost [Woodward 1997].

The inflation rate was chosen based on official average EU rate of 2 % [MEErP 2011]. For large investments it is common that money is borrowed from the bank. The interest rate is thus taken

“Classic” eco-design in context to the reference applications

as the rate at which European banks lend money to each other. Based on average (from 2000 to 2013) Euribor (Euro Interbank Offered) 12 months rate, an interest rate of 3 % is used in this analysis [Euribor 2013].

To obtain more accurate results, for electricity costs calculation, rate based on historical data is used instead of aggregated inflation rate. In the period between 2008 and 2012, industrial electricity prices have gone up by about 3.5 % per year in nearly every EU Member State [EC 2014b]. Assuming that the same trend of increasing electricity price will continue in following years, rate of 3.5 % raise per year is used.

Initial costs are considered here to be the product price at which the customer can purchase the product and the installation cost. Product prices for the drives and installation costs used in the analysis are the approximate prices provided by the company. The actual prices can differ taken into consideration different clients, deals and negotiations. The price of the Mill (including the installation) is estimated as 4 times the price of the drive for KMPP. For MD 6 and MD 12 previously estimated price is allocated to weight of respective Mills. Acquisition and installation of products take place at the base year 2014 and are not discounted. Installation costs include the transportation of the product to the customer’s site. **Table 14** summarizes initial costs for mill and drive (separately and together as a product price), installation costs and total costs for each option. It is obvious that the cost of MD 12 is almost double the KMPP, which is of major consideration when the market is capital expenditures oriented.

Table 14: Initial costs, including installation costs and product price for the three products

	KMPP	MD 6	MD 12
Mill Price [€]	6,200,000	6,200,000	9,300,000
Drive Price [€]	1,550,000	2,750,000	4300000
Product Price [€]	7,750,000	8,950,000	13,600,000
Installation Costs [€]	150,000	170,000	210,000
Total Initial Costs [€]	7,900,000	9,120,000	13,810,000

Operation costs during the use stage are assumed here to be only the electricity consumption costs. Water consumption during the operation (e.g. in the cooling system) is neglected as it is reused. Other operational costs (e.g. salaries) are not considered in the present analysis.

Electricity cost is depended on operating time, power generated and electricity price. For MD 6 and MD 12 energy efficiency of 5% is assumed. The operational profile and electricity consumption of each product are given in the **Table 15** below.

Table 15: Operational profile and electricity consumption for the three products

	KMPP	MD 6	MD 12
Daily operation [hr/d]	23	24	24
Production rate [tn/hr]	150	150	300
Power [kW]	6,000	6,000	12,000
Electricity consumption [kWh/yr] (5% efficiency for MD6&12)	50,370,000	49,932,000	99,864,000
Time to fulfil the FU [years]	20	19.2	9.6

For the electricity price European average for industrial consumers is assumed. The electricity price used is 0.094 EUR/kWh [Eurostat 2014], which is, according to European Commission statistics, the average price for electricity in EU (28 countries) for 2013 (excluding VAT and other recoverable taxes).

Here the geographical scope for the use phase is defined as Europe, meaning that the operation for clinker production takes place in Europe and the price of electricity consumption corresponds to European power generation market. However, it is important to mention that electricity pricing varies widely between countries and can differ significantly even within the same region. The market of electricity or power generation is driven by a number of factors, such as, type and price of the fuel used, government subsidies and regulations, and even weather driven patterns. On average across the Europe in 2012 medium-size industrial consumers in the EU paid about 20% more than companies based in China, about 65% more than companies in India. Within Europe, dispersion of electricity prices for industry was 3.85 (Max/Min) for 2012 [EC 2014b].

**Table 16** shows total operation costs per FU of each product calculated at present value. It can be seen that MD 12 has the lowest costs. That is due to the fact that MD 12 has double production rate compared to KMPP and thus needs less time to fulfil the FU, which is important when increasing electricity price trend is assumed.

Table 16: Total operational costs at present value per functional unit for each product

	KMPP	MD6	MD12
Electricity price [€/kWh]	0.094	0.094	0.094
Electricity cost [€/year]	4,734,780	4,693,608	9,387,216
<b>Total Operation Cost PV [€]</b>	<b>100,734,369</b>	<b>95,673,619</b>	<b>93,446,320</b>

Since no detailed information on maintenance costs is available, maintenance cost is assumed based on average annual maintenance cost of steel “Tun island ferry” (for maintaining the



machinery, the superstructure and the hull) [Lindqvist 2012]. In general, maintenance cost is expected to increase with age; however, here an average value is used (based on ferries of different ages). Hence, no changes in annual maintenance cost are considered within the lifetime.

For MD 6 and MD 12 annual maintenance cost is assumed to increase compared to KMPP proportionally with the total weight. Additionally, change of motor after 10 years of operation is assumed, since motors have smaller technical life time (in this case assumed as 10 years). This additional cost is only relevant for KMPP and MD 6, as MD 12 needs only 9.6 years to fulfil the FU. Price of the motor (6 MW or 3x2 MW) is estimated to be 350 thousands EUR at current prices. Motor price calculated at future cost is therefore added after 10 years to the maintenance costs of KMPP and MD 6.

The EoL costs or credits are considered when the product is taken out of service. Thus, here the EoL of each alternative takes place when the FU is fulfilled and customer no longer need the product. The value at the end of life can be estimated as the rest value of the product or by using the disposal/recycling costs. The rest value of the product is considered when the years that the product had in operation are less than its technical life time. The life time of the vertical mills is assumed to be 20 years, while, for instance, the time MD 12 needs to fulfil the FU is 9.2 years, meaning that the rest value is applied. On the other hand, for KMPP the service life ends at the same time as the technical lifetime, meaning that only the value from recycling the materials can be taken into account together with disposal costs.

The rest value of MD 12 is assumed to be 30 % of the product price. MD 12 operates for almost half of its lifetime and can be operated for 10 more years; however the rest value is taken to be less than 50 % of its product price due to the age. For MD 6 the rest life is less than 1 year, therefore disposal and recycling are considered, instead of the rest value.

All the materials are considered to be recycled at the rates given in EoL scenario of LCA. Credit from recycled materials is then calculated based on current market prices of secondary materials [Europe Scrap Prices 2014]. The non-recycled fraction that goes to landfill is assumed to have a disposal cost of 70 EUR/tn. Recycling process is approximate to have cost of 60 EUR/ton for all the materials. These costs are assumed based on data for recycling and landfill of steel (as steel is the main material fraction) found in literature [Ruffino & Zanetti, 2008]. From incineration of waste no cost or credit is assumed.

**Table 17** now summarizes all estimated total costs per cost element for base option (KMPP) and two alternatives, as well as, their total life cycle cost calculated per FU. All costs are expressed at present value. Additionally, relative change (RC) in total cost of alternatives compared to the base option is calculated.

Table 17: Costs per cost element and in total given at present value for the three products, together with relative change in total costs of the alternatives to the base option. All costs are calculated per functional unit.

	KMPP	MD6	MD12
Initial costs [€]	7,900,000	9,120,000	13,810,000
Electricity costs [€]	100,734,369	95,673,619	93,446,320
Maintenance cost [€]	1,583,152	1,598,408	707,664
Disposal/Rest value [€]	-241,282	-256,776	-4,143,000
<b>TOTAL [€]</b>	<b>109,976,239</b>	<b>106,135,250</b>	<b>103,820,985</b>
<b>RC to KMPP</b>		<b>-3.5 %</b>	<b>-5.6 %</b>

It can be seen that there is 3.5 % and 5.6 % reduction in costs of MD 6 and MD 12 respectively compared to KMPP. That difference comes mainly from the electricity costs. It is obvious that operation has the largest contribution. MD6&12 have smaller electricity cost, compared to KMPP, which is due to 5 % energy efficiency and due to the fact that less time is needed to produce the same amount. The share of each costing element is shown in **Figure 46** and given in percentage of total cost in the **Table 17**. Electricity costs are responsible for more than 90 % of total life cycle costs.

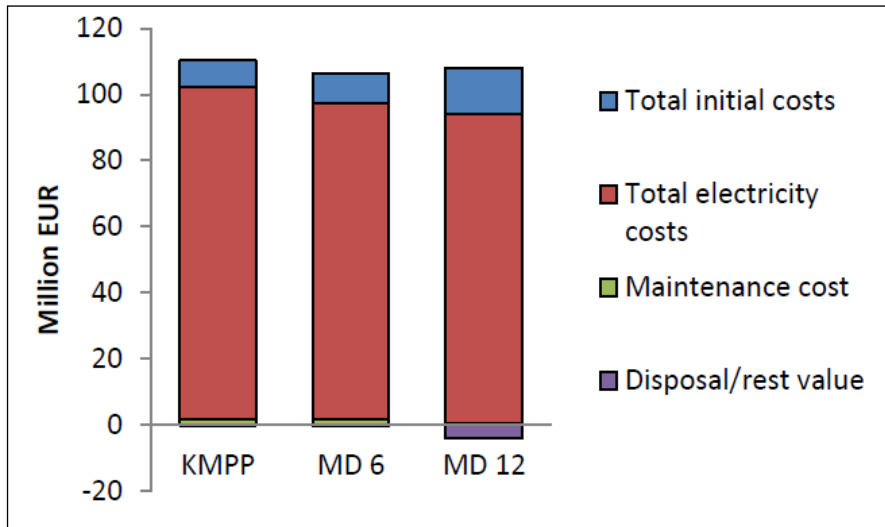

Figure 46: Share of cost elements in the total life cycle costs of each alternative [R-IV].

In terms of sensitivity analysis of the parameters ‘Price of electricity’, ‘Electricity price raise rate’, ‘Inflation rate’, ‘Interest rate’, were checked and the following conclusions drawn:

- Choice of interest and electricity rates is critical for the results of the comparative costing analysis as the results appear to be highly dependent on these parameters;
- High uncertainty of the results is thus expected due to impossibility to predict exactly the electricity price change and to specify the interest rate;
- It must be highlighted that opposite conclusions can be drawn based on the choice of these parameters;

- The sensitivity of the total cost to electricity price is significant; however, it has no implication on the conclusion when comparing the alternatives to the base option;
- The choice of inflation rate is not of high importance to the analysis, as the sensitivity to this parameter is very low and the conclusion from the comparison is unchanged when different inflation rates are examined.

### 7.3.2.3 ECO-CARE-MATRIX

In context to ECM, generally it should be analysed which, for displaying the environmental benefit, impact categories should be displayed. In this case the analysis conducted, lead to the results that it must be drawn for ADP(met), HTP, GWP.

For the customer benefit analysis the results of LCC are used. Customer benefit is defined as relative change in total life cycle costs of the two alternatives to the reference option (KMPP) calculated per same FU as LCA and expressed at net present value.

When considering GWP (**Figure 47**, exemplary shown), it can be seen that both alternatives have higher Environmental Benefit of approximately 5 %. For Customer Benefit, also both MD 6 and MD 12 appear to have higher benefit of 3% and 6%, respectively. Therefore, both MD 6 and MD 12 are considered a ‘green solution’. When ADP(met) is taken as the Environmental Benefit, the environmental benefit of the two alternatives is higher than the base option. MD 6 has a benefit of 15%, while MD 12 has the highest benefit of 31 %. Thus, MD 6 and MD 12 are a green solution. When the environmental benefit

“Classic” eco-design in context to the reference applications

is represented by HTP, both alternatives have an Environmental Benefit of 5 % and 7 % respectively.

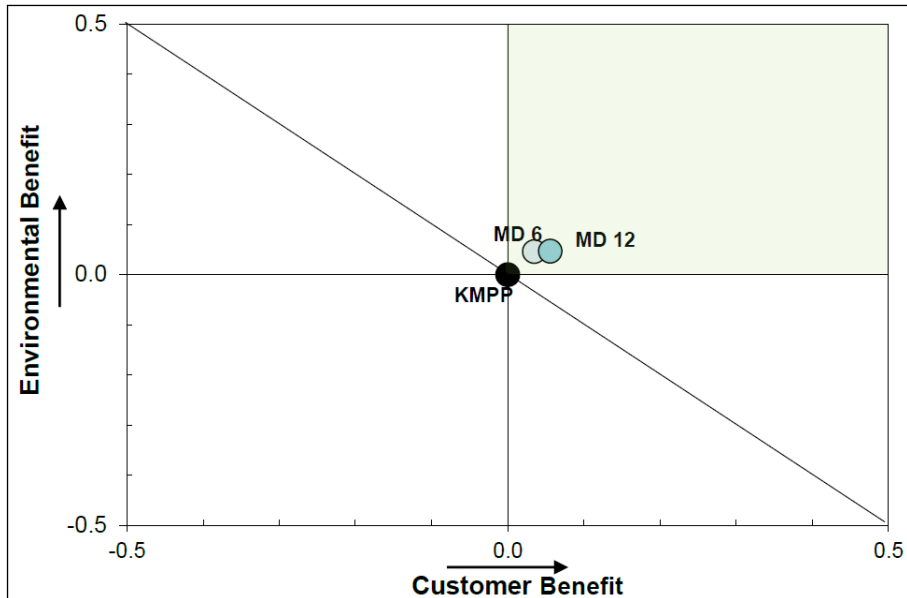

Figure 47: Eco-Care-Matrix for the three products considering GWP as environmental benefit, where the “green solution” is in the upper right [R-IV].

Overall, it can be concluded that MD 6 and MD 12 have higher Customer and Environmental Benefit for the three impact categories considered, thus MD 6 and MD 12 are the green solution.

### 7.3.3 DISCUSSION & CONCLUSIONS

The LCA performed on the three products showed that the use stage was dominant, accounting for more than 90 % of the total impacts, except for metal depletion. This is because of significant impact on energy consumption, generated due to the high operating profile of the products, which is the case for products classified as energy-related. Similar result of dominated

use stage in most of the impact categories was also showed by other LCA case studies of ErPs performed [Junnila, 2008].

The only category where the impact from the production stage of the drive components was dominant was Metal depletion. This category is affected by raw material extraction and manufacturing of parts and products. The highest contribution to metal depletion came from the mechanical parts, e.g. the gearboxes.

Overall from the LCA performed, it was concluded that the most affected categories for the three products, based on midpoint results were ionising radiation, followed by fossil resource depletion, as these categories are highly affected by the large amount of energy consumption.

The comparative study between base option, KMPP, and the two alternatives (MD 6 and MD 12) showed that both alternatives have a better environmental performance in all the categories. For Metal depletion, the difference between KMPP and MD 6 was only of 1.2 %, because the scaling factor of MD 6 (to fulfil the FU) is 0.95, meaning the comparison is approximately one to one; while for KMPP and MD 12, the difference was of 19.6 %, due to the scaling factor of 0.48, which means the comparison is almost two to one. It should also be noted that the mill was modelled the same for KMPP and MD 6, whereas for MD 12, the mill is 1.5 times larger, based on assumptions. As the manufacturing of the mill has a high impact on the production stage, hence Metal depletion, a change on this assumption is expected to have a high impact on the result of this impact category.

For the rest of the categories, the difference between KMPP and MD 6 and 12 was approximately 4.5 %. As the three products have the same energy consumption (the amount of clinker produced is fixed), this difference is due to the 5 % energy saving assumed during the use stage. This 4.5 % difference is considered as significant, since this amount corresponds to more than 20 million kg of CO<sub>2</sub>-eqv. saved, which is 10 times the kg of CO<sub>2</sub>-eqv. emitted during the production stage.

The LCC comparative study between KMPP and MD 6 and 12, showed a reduction in the total life cycle costs of 3.5 % and 5.6 % respectively, which is mainly due to the electricity costs. Since the time to fulfil the FU differs (19.2 years for MD 6 and 9.6 years for MD 12), and an increase of electricity price is assumed, there is a higher electricity cost for KMPP. Moreover, the 5 % energy saving was considered for MD 6 and 12.

The use stage (i.e. electricity costs) had the largest contribution to the total costs, contributing to 90 % of the total life cycle costs. For end of life costs, MD 12 presented a higher number (4 %) due to the fact that after 9.6 years it is sold as rest value, which was assumed to be 30 % of the total product price, whereas KMPP and MD 6 are sold as recycling credits, a much lower cost.

Overall, MD 6 and 12 are the economically preferable option based on the defined scenario and assumptions. However, it must be reminded that due to the number of assumptions and parameters considered, especially those affecting directly the operation cost (such as energy saving percentage, interest rate, increased electricity price rate) a degree of uncertainty is expected on the study.



The ECM applied on the selected impact categories, which were found to be relevant, showed that MD 6 and 12 are the “green solution”. The highest difference between the alternatives was seen when the Metal depletion impact category was considered as the environmental benefit, where MD 12 had the highest benefit.

Sensitivity analysis showed that change of parameters connected to the use stage was estimated to have high implication on the results, both in LCA and LCC.

It should be highlighted that the study results are limited to Europe region and do not reflect the performance of the product in other place of the world. The results are also limited by data availability and assumptions made through the study and for the definition of the analysed scenario. Additionally, interpretation of the results was made using specific methodology (ReCiPe), thus is limited to selected method and impact categories covered.

From the performance of LCA the following was concluded:

- Use stage is dominant in all of the categories, except Metal depletion
- MD 12 and MD 6 have better environmental performance in all of the categories
- In most of the categories the difference in environmental performance is around 4.5 %
- Environmental benefit of MD comes mainly from 5 % energy saving

“Classic” eco-design in context to the reference applications

- The 4.5 % environmental benefit is considered significant, when translated in the amount of CO<sub>2</sub>-eqv. saved
- Change of parameters connected to the use stage is estimated to have high implication on the results

The LCC analysis resulted in the below main conclusions:

- Use stage has largest share (90 %)
- MD 12 is economically preferable option, followed by MD 6
- Economic benefit comes mainly from different operation profiles
- The comparative results are highly dependent on choice of electricity price rate and interest rate
- High uncertainty of the results due to impossibility to predict electricity price change and interest rate

Based on combined LCC and LCA results, the ECM drawn for Climate Change, Metal depletion and Human toxicity categories (identified as relevant) showed that MD 12 is the “green solution”, followed by MD 6. However, it was specified that the results are limited to the defined scenario.

From the performed study, recommendations to the company were derived for utilization in the product environmental management:

- Data collection from the customers site: exact operation profile, mill production data

- Use the current project as a template to perform a similar analysis for the customer's specific scenario, with complementary data provided by customer
- Change of variable speed drive to fixed speed to reduce initial costs of MultipleDrive should not be considered, as most environmental benefit comes from the energy saving provided by the variable speed
- Focus more on developing energy saving solutions for use stage
- For LCA of similar products, where the impact from overall life cycle is to be estimated, it is enough to consider only the use stage, with no need for detailed production and EoL modelling

## 7.4 LIFE CYCLE ASSESSMENT OF MOTORS

### 7.4.1 GOAL, SCOPE & LIFE CYCLE INVENTORY

The study aims to compare the potential environmental impacts of motors of one product family (same technology, same product type, same power rating) with different efficiency classes over the whole life cycle in the current European context of the 'EcoDesign Directive' and the 'Circular Economy Package'. The goal is to evaluate the trade-off between the materials & manufacturing stage (more copper, higher grade electrical steel etc.) and usage (less power consumption through higher efficiency) in detail and to additionally conduct a hot spot analysis, which results may be used internal in product design.

As stated in section 6.4, the main purpose of an electrical motor is to convert electrical power into mechanical power for various

“Classic” eco-design in context to the reference applications applications, e.g. conveyor belts, pumps, fans. The products under study are Siemens motors of type Simotics SD basic, cast iron series, 4-poles, 50 Hz, self-ventilated with the international efficiency (IE) classes IE2, IE3, IE4, whereas the efficiency classes are defined in [IEC 60034-30-1].

The functional unit (FU) was defined as the provision of mechanical power in an applied usage scenario (operation profile, load-time profile) by electrical motors with 110 kW nominal power at 365 days a year in 20 years of service life. For the two applied usage scenarios, the reference FU, used in the comparative assessment and derived from the corresponding output (mechanical power) of the motor with efficiency class IE2, was defined as:

- (1) Scenario A): High duty - Provision of 15,658,500 kW nominal power;
- (2) Scenario B): Low duty - Provision of 8,431,500 kW nominal power.

The reference flow was determined as [kg] of electrical motor (baseline IE2-motor: 707 kg, range up to 744 kg for IE4-motor).

The assessment includes all life cycle stages from cradle to grave. The system boundaries were defined according to [EN50598-3:2015], also taking into account the defined parameters, like for end-of-life. The manufacturing stage includes all processes associated with producing the motor, from the upstream processes such as mining of metal ores and extraction of crude oil, to the final assembly of the motor, including forming processes for the semi-finished goods, like stamping, bending, die-casting and impregnation / insulation.

**Figure 48** schematically displays the set system boundaries including the background and foreground data.

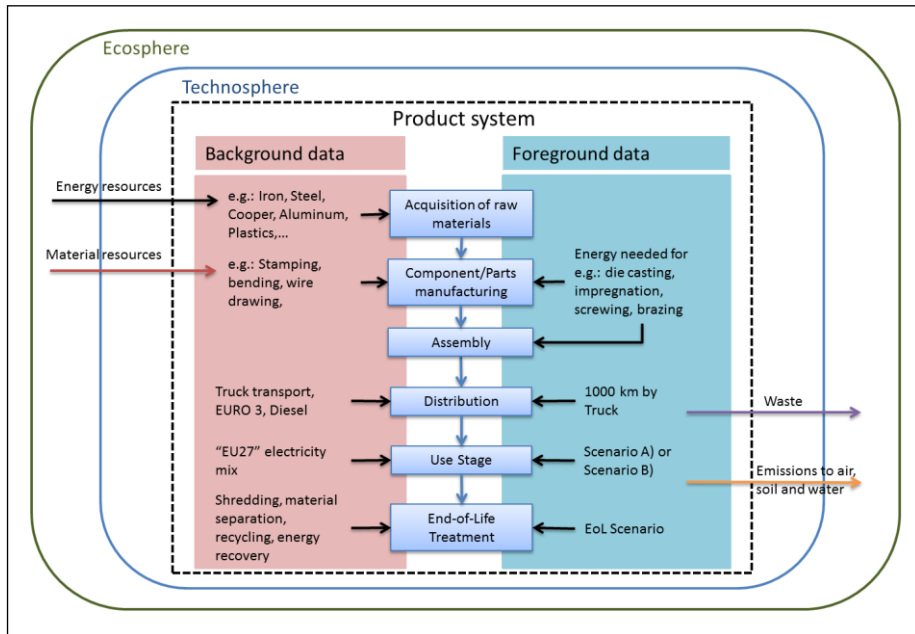

Figure 48: Graphical display of the system boundaries of the LCA case study to evaluate the environmental performance and potential trade-offs between motors with different efficiency classes in two different usage scenarios [JP-II].

For final assembly (e.g. screwing), die-casting and impregnation, the energy consumption has been allocated to the motor based on the factory's reported data from 2011. For the other processes generic data (e.g. punching, bending, wire drawing, coating...), as available in the corresponding tool and database, were used. Distribution has been considered as 1000 km truck transport within Europe. Not considered were the transport of materials to production site, initial sample tests, all activities concerning the superstructure (building of and maintenance of the production

“Classic” eco-design in context to the reference applications facilities, tools and machines), and resources for R&D, planning and sales. No further cut-off criteria were applied.

The modelling framework of this study is set to the attributional principle, depicting the existing value chain, i.e. use the current state of the art data of the modelled system. For instance the German electricity grid mix is used for the motor production, since it's build in Germany, the EU27 electricity was used for the assessment of the use stage, as well as end of life processing because the location of the application is assumed to be “somewhere in Europe”. Multifunctionality of processes is solved using allocation based on physical properties (weight) and economic data (working hours). In this context, it shall be considered that the systems do not have secondary functions to providing mechanical power and any occurring problems of multifunctionality of the product systems in manufacturing and end-of-life are handled in the same way.

For the life cycle impact assessment (LCIA) the midpoint characterization methods recommended by the European Commission's Joint Research Center (JRC), Institute for Environment and Sustainability, published as part of the ILCD handbook are used [ILCD 2011]. These are also used in the context of the Product Environmental Footprint (PEF) initiative by the European Commission and therefore currently very relevant to industry, due to a potential application in policies. Internal and external normalisation was applied to support the interpretation of the LCIA results, by relating the LCIA scores to defined bases. Consequentially for external normalisation the Normalisation Factors (NF) per Person (PE = Person Equivalent) as defined in the PEF guide for the products are

used, which relate the LCIA results to the European domestic inventory in 2010. Per person normalisation factors (Person Equivalents) have been calculated using Eurostat data on EU 27 population in 2010. Characterization methods and NF are listed in **Table 18** below [EC 2016]. Further following the PEF guide, weighting currently is applied using the weighting factor 1 for all impact categories. It should be noted that, corresponding to the reference [ILCD 2011], certain characterization methods – even though being recommended – still are rated with Level III for data quality and should therefore be considered with caution in interpretation. The same caution should also be taken when drawing conclusions from normalized LCIA scores. Normalisation is needed to enable the comparison across impact categories, but external normalisation is questionable as potential normalisation bases still lack political and scientific consensus concerning the so-called areas of protection (environment, resources, toxicity) [Bjørn and Hauschild, 2015].

Key aspect to potential environmental and toxicity impacts of electrical motors, being electromechanical products, is the material composition. Processes for extracting ore out of earth and making “usable”, raw material out of it, are the drivers of environmental effects like acidification or global warming, as well as related effects like resource depletion [Herrmann et al., 2012].

“Classic” eco-design in context to the reference applications

Table 18: Characterization methods applied in the study, as recommended by ILCD for life cycle assessments in European policy context. The normalisation factors (NF) as Person Equivalents (PE) are taken from the PEF guide for pilot studies [PEF 2016].

<i>Abbreviation</i>	<i>Characterization methods and models</i>	<i>Unit</i>	<i>Normalisation Factor (NF)</i>
TE	Terrestrial eutrophication, Accumulated Exceedance model	molc N eqv.	1.76E+02
FE	Freshwater eutrophication, EUTREND Modell, ReCiPe	kg P eqv.	1.48E+00
ME	Marine eutrophication, EUTREND Modell, ReCiPe	kg N eqv.	1.69E+01
PM	Particulate matter, RiskPoll	kg PM2.5 eqv.	3.80E+00
PCOF	Photochemical ozone formation, LOTOS-EUROS Modell, ReCiPe	kg NMVOC eqv.	3.17E+01
RD, w	Total freshwater consumption / Resource Depletion – water, UBP 2006	UBP	8.14E+01
HT, c	Human toxicity, cancer effects, USEtox	CTUh	3.69E-05
HT, nc	Human toxicity, non-cancer effects, USEtox	CTUh	5.33E-04
IR	Ionizing Radiation – human health effects, ReCiPe	kg U235 eqv.	1.13E+03
GWP	IPCC global warming, w biogenetic CO <sub>2</sub>	kg CO <sub>2</sub> eqv.	9.22E+03
ET, f	Ecotoxicity – aquatic, freshwater, USEtox	CTUe	8.74E+03
OD	Ozone depletion, WMO Modell, ReCiPe	kg CFC-11 eqv.	2.16E-02
RD, f+m	Resource depletion - fossil and mineral, CML 2002	kg Sb eqv.	1.01E-01
A	Acidification, Accumulated Exceedance model	mol H+ eqv.	4.73E+01

For this case study the material composition of the parts of an electrical motor were summarized to certain material groups, resulting in the material composition of the motors of different international efficiency (IE) classes as displayed in **Table 19**



below. The table also includes assigned generic processes from the Gabi database.

Table 19: Material composition of the motors with different IE classes. The IE2-motor is the reference for the percentages displaying the increase for certain material groups when the efficiency is increased.

<i>Material group (assigned generic treatment processes)</i>	<i>IE2</i>	<i>IE3</i>	<i>IE4</i>
Electric sheets (stamping)	271 kg	10%	10%
Cast Iron (die casting)	271 kg	0%	0%
Copper (wire drawing)	69 kg	4%	10%
Other Steel (stamping and bending)	64 kg	0%	0%
Packaging Material (wooden pallet production)	24 kg	0%	0%
Aluminum (extruding)	19 kg	5%	5%
Impregnation Resin	5 kg	20%	20%
Others: Other materials with mass below 5 kg and no difference between the IE classes: Plastics (injection molding), Insulation, Paint (painting), Rubber, Brass (stamping and bending), Solder (brazing) & Grease	9,8 kg	0%	0%

**Figure 49** displays the material fractions that have been increased in quantity to reach the higher efficiency levels accordingly. These material groups then have been matched to a corresponding, most representative LCI processes in GABI, reflecting the inputs, like crude oil or copper ore, and outputs, like CO<sub>2</sub>-emissions or metal scrap, of this manufacturing step.

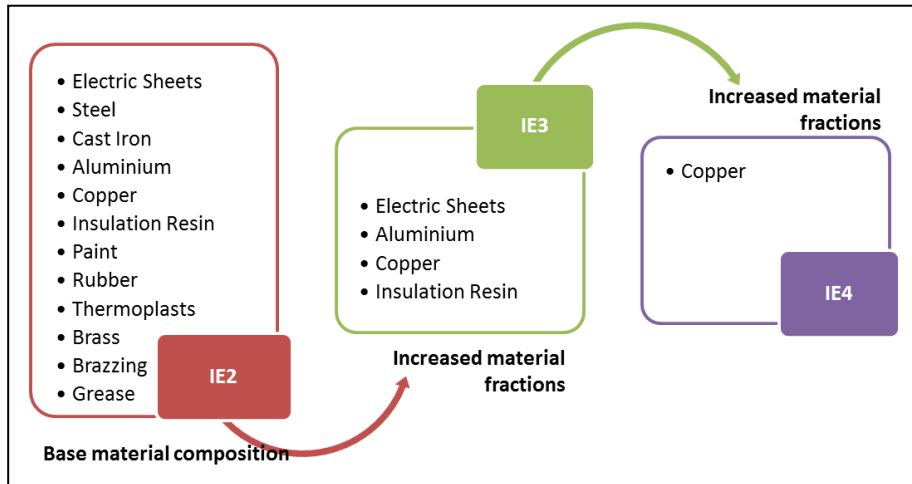

Figure 49: Display of material fractions increased, from the base material composition of an international efficiency class 2 (IE2, high efficiency) motor, to achieve higher efficiency levels: International efficiency class 3 (premium efficiency) and 4 (super premium efficiency) as defined in IEC 60034-1-30. No material fractions decrease in this regard [JP-II].

After this, the most representative machining or treatment process, like wire drawing or die-casting (see also **Table 19**), is added to the material group to reflect the aspects of the finishing processes, including energy consumption and typical material losses as available in the generic data sets. To finally finish the model of motor manufacturing, the last step added is the final assembly. The energy consumption for assembly, including varnishing/impregnation was approximated based on an allocation of the 2011 annual energy consumption by working hours. Parts or material transport is only included as far as reflected in the generic data. Distribution of the final product to the usage location is considered by transportation by truck (consuming diesel) and a distance of 1000 km.

The use stage is known in drives for being the (by far) most relevant, because of the purpose of the functionality of transferring electrical energy into mechanical power. Use stage in drives, including motors, is characterized by an operating profile, defined by the time fraction the component is operating at specific operating points [EN 50598-1:2015; EN50598-2:2015]. These operating points of motors are characterised by the motor's load at a certain speed in percent of their nominal values. Further, the motor's efficiency (or rather the losses) depends on these values (load, speed) and is therefore specific for the operating points. The operating or load-time profile itself puts them then into context to a defined amount of time, e.g. the time fraction the motor runs at the specific operating point in the applied use scenario [Auer & Weis, 2014]. Operating profiles, in principle displayed in Figure 3 can roughly be distinguished into two types:

- (1) Fixed speed operation – Applications with a constant load and speed, e.g. simple conveyor belts;
- (2) Variable speed operation – Applications with variable load and speed, e.g. centrifugal pumps with variable flow.

For this case study, two application scenarios were defined by the means of operating profiles and a reference service life, to evaluate the use stage and the potential environmental improvements through higher efficiency levels. The two scenarios, displayed in **Figure 50**, were chosen to take into account a high duty, Scenario A), and a low duty operation, Scenario B), and to reflect the results then in this context. Both

“Classic” eco-design in context to the reference applications scenarios are basically variable speed operations, which are more common for motors with power ratings corresponding to the ones of this case study [Almeida et al., 2014].

The relevant parameters (speed, load and time fraction, corresponding efficiencies) of the two scenarios are displayed in

Table 20. For the reference of the comparative assessment, the IE2-motor, this then corresponds to the respectively defined functional unit laid down in the goal and scope.

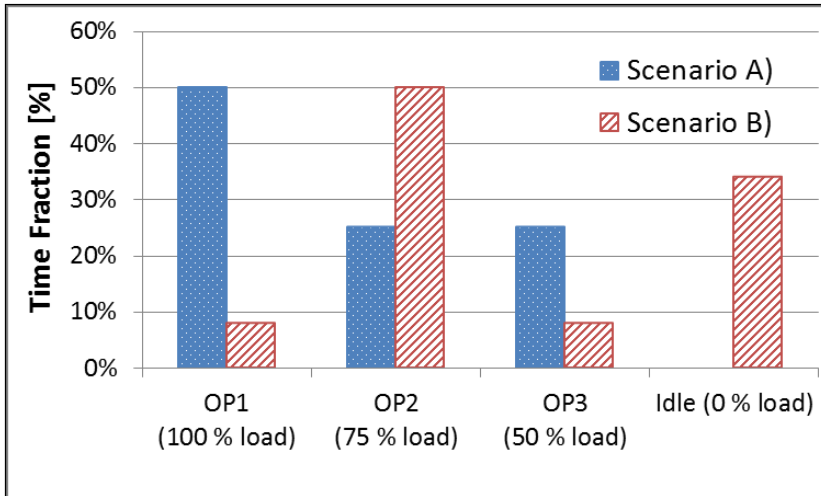

Figure 50: Graphical display of the two operating profiles corresponding to Scenario A) and Scenario B) applied in the case study [JP-II].

Table 20: Relevant parameters of two use stage scenarios applied in the LCA of the motors with different efficiency (IE) classes. The scenarios are characterised by an operating profile, i.e. the amount of time (percent of 24 h) the motor works at specific operating points (OP). The OP is characterised by the speed and load of the motor in terms of percentage of their nominal values.

<i>Usage: Scenario A) / calculation scheme</i>				
<i>load</i>	<i>speed [%]</i>	<i>load [%]</i>	<i>time [%]</i>	<i>time [h]</i>
operating point 1 (OP1)	100	100	50	12
operating point 2 (OP2)	100	75	25	6
operating point 3 (OP3)	100	50	25	6
Idle	0	0	0	0

“Classic” eco-design in context to the reference applications

<i>Usage Scenario B) / calculation scheme</i>				
<i>load</i>	<i>speed [%]</i>	<i>load [%]</i>	<i>time [%]</i>	<i>time [h]</i>
operating point 1 (OP1)	100	100	~8	2
operating point 2 (OP2)	100	75	50	12
operating point 3 (OP3)	100	50	~8	2
Idle	0	0	34	8
<i>Product, Efficiency [%] at OPs</i>		<i>OP1</i>	<i>OP2</i>	<i>OP3</i>
Motor 1 (IE2)		94	94,6	94,5
Motor 2 (IE3)		95,5	95,8	95,4
Motor 3 (IE4)		96,4	96,6	96,3

The input flow of electrical energy was fed by “EU27 power mix”, as the currently available European average in the GABI database.

For end-of-life stage, current available technologies and (pre-)treatment steps are combined to a most likely, representative scenario based on [Kasper et al., 2015] and [IEC/TR62635:2012], an internal research project [Süß, 2007], and discussions in an European work group for motors, currently developing PCR for LCA of motors [CLC TC2 WG2], aligned EN50598-3. For the case study the scenario was defined as follows: The whole motor is disassembled into the main parts (housing, stator, rotor, windings), which are then shredded. This is then followed by material separation by physical properties, e.g. eddy-current and density, routing the different fractions to material recycling (metals, wood), energy recovery (insulation/impregnation, plastics) and landfill (ceramics, recovery/recycling process losses). 5 % of losses were assumed for recovery and separation processes, whereas generic datasets were used for recycling, recovery and landfilling processes,

including material specific recycling quotes and further necessary inputs. Crosschecking with [Almeida 2008], [Almeida 2014] and [Karlsson and Järred, 2000], this approach and the corresponding, high recycling quotes (~ 95 %) were assumed to be realistic. Potential credits, through the avoidance of virgin metals production and/or energy recovery through polymer materials, are then displayed as in the LCIA results for end-of-life stage; this means that there was no direct crediting to other life cycle stages within the model.

#### 7.4.2 RESULTS: LIFE CYCLE IMPACT ASSESSMENT

The results of the life cycle impact assessment with applied external normalisation and weighting, using the normalisation and weighting factors of the PEF guide for pilot studies (Version 1.6), for each of the motor types and life cycle stages for both usage scenarios are displayed in **Figure 51**.

“Classic” eco-design in context to the reference applications

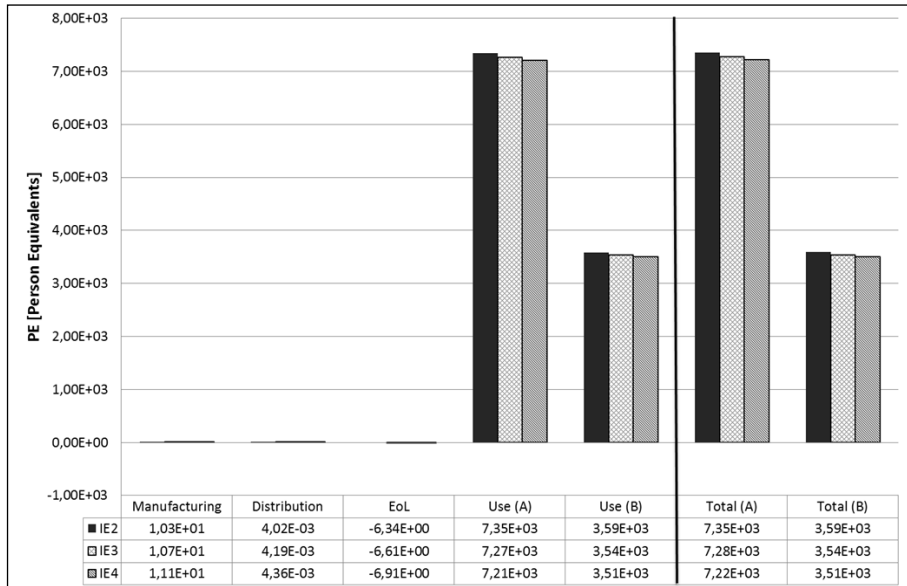

Figure 51: Externally normalized, weighted and aggregated LCIA scores in terms of Person Equivalents (PE) for the 3 electric motor types (IE2, IE3 and IE4) [JP-II].

Looking at the impact scores displayed, at first it can be stated, that the use stage is by far the most relevant life cycle stage, as the other life cycle stages are not even visible in this scale. Secondly it can be seen that for both scenarios the increase in the motors’ efficiency reduces the environmental impacts expressed in PE. Based on this, it can be determined that the most relevant impact categories for electric motors are ionizing radiation (IR), water depletion (RD, w), and global warming potential (GWP), and all these are predominantly driven by the amount of electricity that is converted in the use stage of the motors.

Taking a deep dive into the manufacturing stage, it can be seen that the distribution of the contribution of the analysed impact categories to the total score in PE is more-or-less comparable between the different motors. The small differences that are



observed can be assigned to the change in the material composition between the motors. Secondly, it could be evaluated, that the EoL stage corresponds to the manufacturing stage, which means on the one hand that due to the motors composition of mainly metals, the high recycling quotes theoretically compensate more than half of the impacts from manufacturing and material stage and therefore the increase in impacts with the higher energy efficiency are also partly compensated by a higher benefit from recycling.

Then it was concluded that that the distribution stage is indeed insignificant and at last, that fossil and mineral resource depletion, human toxicity and particulate matter are the most relevant impact categories at the manufacturing and end-of-life stages. In the further it the analysis showed that the main materials (copper, iron, steel) of the motors are also the main drivers, accounting for about 90 %, of these potential environmental impacts, besides acidification and global warming where the assembly process is also a main contributor due to its use of electricity. The materials in focus for further interpretation are the electrical sheets, steel and die-cast iron, as well as copper.

To see if there are issues across the motor types, e.g. significant changes concerning the relevance of impact categories, an internal normalisation in terms of “Division by Baseline” (DBB) was applied [Laurent and Hauschild, 2015], where the results of the IE2-motor provides the baseline. The results with an applied usage Scenario A) (see Table 1) are displayed in **Figure 52**. Here it can be seen that in that usage scenario, all potential environmental impacts are reduced, and the reduction of the potential environmental impacts correlates with the increase of the efficiency classes. On average, electricity-related efficiency

“Classic” eco-design in context to the reference applications

in the use stage is increased by about 1.2 % per efficiency class, and most of the potential impacts are then roughly reduced about 1 %. This is, however, not applicable for Human Toxicity (HT, cancer effects) where the reduction of these potential environmental impacts is lower.

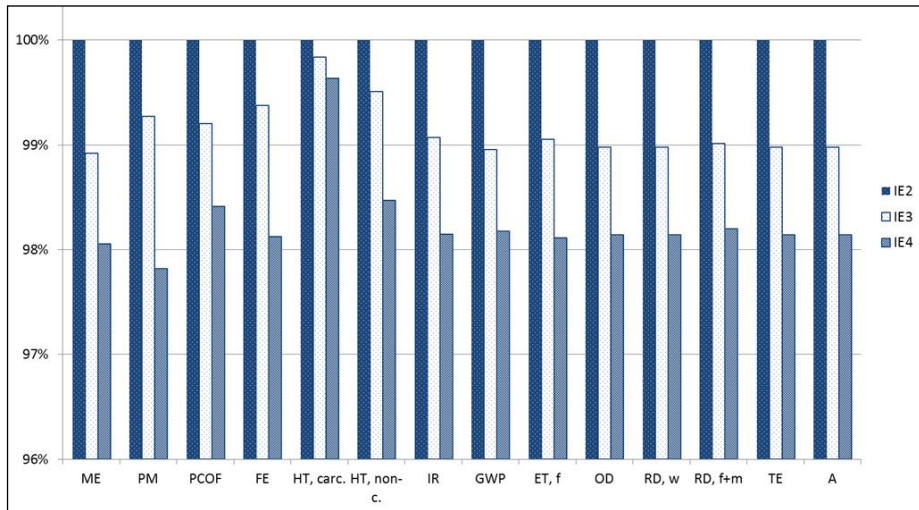

Figure 52: LCIA scores in DBB view with applied usage Scenario A) [JP-II].

The results of the life cycle impact assessment with the applied usage Scenario B) were evaluated accordingly, with applied internal normalisation (DBB), and gave a comparable impression, besides human toxicity (cancer effects) which in this scenario even increases from IE3 to IE4. As the second difference, it was recognized that the improvement of the environmental performance is even higher in all impact categories but Human Toxicity (cancer effects) in comparison to Scenario A).

### 7.4.3 INTERPRETATION & DISCUSSION

According to the impact assessment, it can be summarised that the increase in the motors' efficiency reduces all environmental impacts over the complete life cycle in both usage scenarios, besides human toxicity (cancer effects).

The increase of materials, like copper or steel in this case, in the motor's composition results in higher impacts in manufacturing, which on the other hand, in theory are compensated to some extent by material recycling and/or energy recovery at the end-of-life stage. This relation is valid for all motor types (IE2 to IE4). Allocating the potential benefit of the end-of-life stage through recycling to the manufacturing (closed loop approach) stage, the environmental impact of manufacturing is compensated by 62 % in PEs, by 52 % in GWP and by 3 % in Human Toxicity (non-cancer effects). The end-of-life stage itself was not analysed further within the case study, since these details (e.g. different recycling scenarios) were not in the scope of the study, but it should be considered that the potential credits through recycling are quite high, but assumed to be realistic for motors of this size and weight, due to their low material complexity and high amount of valuable metals with associated, established separation and recycling processes. Crucial for high recycling rates is to separate copper from iron, because copper negatively influences the recyclability of iron/steel [Alatalo et al., 2011]. This is taken into account by the disassembly of the main parts before shredding. Other end-of-life treatment scenarios, because theoretical recovery and recycling may not be always met in practice, will affect the relation between manufacturing and end-of-life stage. In other words, better recycling will compensate impacts associated with utilizing of

“Classic” eco-design in context to the reference applications

more material more, lower recycling and/or recovery will compensate less.

Looking at the normalized results of the LCIA of the manufacturing stage, the most relevant potential impacts are fossil and mineral resource depletion, human toxicity, ionizing radiation, global warming and particulate matter. The main, top three, contributors to these impact categories were evaluated, accounting to about 90 % of impact within the respective category. The results are summarised in **Table 21** for further interpretation.

Table 21: Summarized results of the life cycle impact assessment displaying the main impact categories with their main drivers for motors manufacturing

<i>Main Impact category</i>	<i>Main drivers</i>
Resource Depletion, fossil + mineral	Copper, Brazing
Human toxicity, cancer effects	Electrical sheets, Iron (die-cast), Steel
Human toxicity, non-cancer effects	Electrical sheets, Steel, Copper
Acidification	Electrical sheets, Cooper, Steel
Global warming potential	Electrical sheets, Assembly process, Copper
Particulate matter	Iron (die-cast), Copper, Electrical sheets

In that context, results showed that the material selection in regard to improving the efficiency of motors is important concerning associated environmental impacts. Main contributors to the overall losses of the motor during use are losses in the functional materials copper and iron (electrical sheets), as well as in the air gaps [Volz, 2010]. So, besides optimizing the motor construction (e.g. reduction of air gap losses) within the established motor technologies, increasing the efficiency basically requires more or higher quality material which reduces

these losses – even though it has to be mentioned that this is a very simplified approach, because the motor concept would have to be adapted too – and in that context copper and electrical steel are the most important material fractions [Lemmens and Deprez, 2012].

Now from an environmental point of view, the electrical sheets basically increase impacts in the ionizing radiation category, global warming potential and particulate matter categories, whereas copper dominates the impacts of resource depletion and human toxicity (cancer effects) categories. Thus, hot spots in the motors' material composition are the material fractions copper and the electrical sheets. The electrical sheets primarily because of the mass used in the motor, the copper because of the associated processes to produce the material, especially from primary sources which are needed for copper wires [Cowley and McGowan-Jackson, 2004; EU CI, 2015].

In terms of environmentally conscious design, a practitioner now would have to value the corresponding impact categories to justify his choice in regard to either reducing copper losses or the losses in the electrical sheets for improving a motor's efficiency. In that context it also has to be considered that – besides the problem of valuating – in the underlying characterization methods for resource depletion as well as toxicity still are under development and bear a higher level of uncertainty compared to e.g. the impacts related to energy consumption [Huijbregts, 2001] [ILCD 2011]. For resource depletion, current discussions are dominated by the search for the definition of the “right” allocation base [Schneider et al., 2015].

Whereas for toxicity assessments, three major sources of uncertainty can be named: i) Available aggregated datasets still lack certain elementary flows for a robust characterization [Huijbregts et al., 2000], then ii) fate and exposure factors do have strong correlation to the environment, like the geographical scenarios [Huijbregts et al., 2003] and then iii) the characterization itself (e.g. USEtox), is still rather young and thus under continuous development [Rosenbaum et al., 2008]. This has to be considered in any decision support context [e.g. Pennington 1999].

The comparative life cycle assessment clearly indicated that any increase in efficiency is environmentally preferable with the applied usage scenarios (assumed 20 years of operational life) and current technological set-up for electricity generation. After external normalisation and weighting of results, the study clearly indicated the benefits of an improved efficiency in terms of reduced impacts, even when applying a lower duty operating profile (Scenario B)). The extra effort when building a more efficient motor in manufacturing stage, due to the use of more material, as well as distribution, because of the higher weight, is compensated by higher credit at the end-of-life stage, as well as the savings when using the product. In this regard, the pay-off between higher impacts in manufacturing and to the lower impacts in usage for the increased efficiency was calculated to about a month in terms of PE, and only to 8 days in GWP as a representative for the assessed impact categories, related to electricity consumption. The exchange of an IE2 motor with an IE4 motor reduces CO<sub>2</sub> emissions by about 80.000 kg CO<sub>2</sub>-eqv. (4160 kg CO<sub>2</sub>-eqv. per year) in Scenario B) and by 145.000 kg CO<sub>2</sub>-eqv. (7240 kg CO<sub>2</sub>-eqv. per year) in Scenario A). The data

for the comparison of the IE2 with IE4 motor, i.e. the days of operation after which additional efforts in materials, manufacturing and distribution are compensated by savings in the use stage, as well as potential credits from end-of-life, is summarized for PE, GWP, HTc and RD in **Figure 53**.

In this context an additional scenario was added, to check how a different, worse in terms of recycling/recovery rates, approach would influence the break-even in environmental impacts. Therefore, only 50 % of the potential credits from the end-of-life stage were accounted to the motor system.

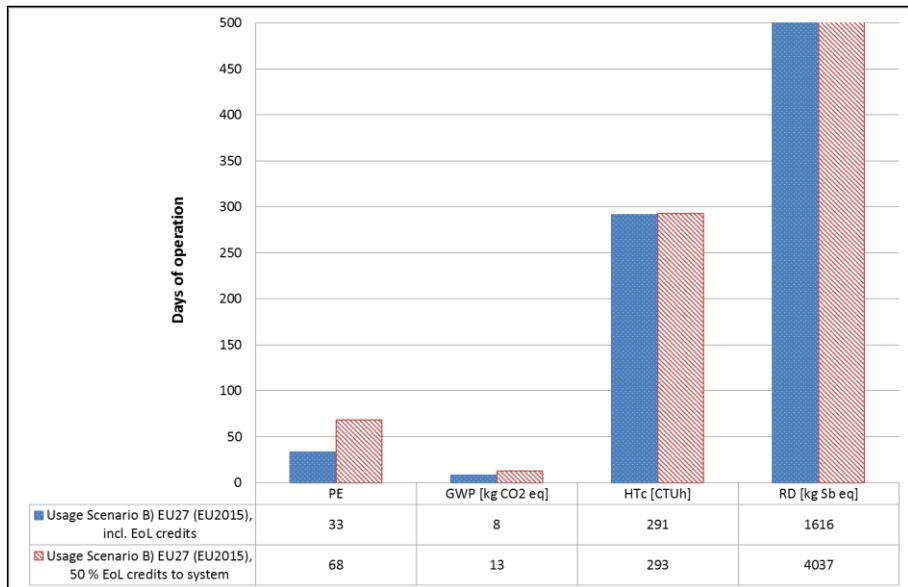

Figure 53: Graphic display of the break-even calculation for the exchange of an IE2-motor with an IE4-Motor in days of operation. It shows after how many days of operation the additional effort in material, manufacturing and distribution is compensated by savings in usage and credits for EoL [JP-II].

Based on this data it can be seen that the additional effort for increasing the motors' efficiency corresponds in terms of GWP

to an additional impact of 204 kg CO<sub>2</sub>-eqv., credits from end-of-life account for 116 kg, leaving net 88 kg CO<sub>2</sub>-eqv. to be compensated at the use stage. Comparing this to the figures mentioned above, it is clear that this compensated quickly. With lower recovery and recycling rates, the time needed for break-even is extended, especially regarding the resource depletion (fossil, metals) indicator.

By applying an internal normalisation by the means of DBB the impact categories’ performance could be assessed individually in between the motors with different efficiency classes. An increase of (Scenario B)) or a lower reduction of potential environmental impacts (Scenario A)) with increase of efficiency could be observed for human toxicity (cancer effects). This is caused by the higher utilization of copper material with the increase of the efficiency class. Since there are not enough savings in that category in the use stage, the total score over the whole life cycle increases with the applied use stage Scenario B). Looking deeper into this issue, the break even for this impact category would be reached, when exchanging a IE2 motor with a IE4 motor, after about 15 years in Scenario A) and after about 27 years in Scenario B). This should be considered in ecodesign decision support context with caution due to the issue of uncertainty of this impact category, as discussed previously. More generally this fact can be seen as an indication that there could be cases were this wouldn’t be true (e.g. other usage scenarios with different load-time profile and/or shorter reference life time) or that when further increasing efficiency it can lead to higher impacts in certain impact categories, as toxicity impacts in this case. Now to further check the robustness of the obtained results,



these points were addressed in the sensitivity analysis in the following section.

Data relevant for modelling (losses of the motors at the corresponding operating points) was taken from SinaSave [SinaSave 2016] and is based on the products technical documentations. Underlying test and calculation methods are standardized and applied in policy context. Therefore it can be rated as of very good quality. The applied use stage scenarios can be rated as representative, but it has to be considered that the application range of asynchronous motors is quite diverse and results in different scenarios might vary. Especially in context it shall be mentioned that besides the operating profile, the operational life and the operating hours per year have a strong influence on the impacts related to the use of the motor. Both parameters correlated to the nominal power of the motors [Almeida et al., 2008]. Additionally to that it should be considered that the impacts from electricity generation are decreasing through the increased contribution from renewable sources, especially wind power, as it is documented for instance for the European Union [Agora 2016]. This potential future energy scenario could affect the interpretation of the comparative assessment and hence should be addressed in a sensitivity check.

To check the obtained results, which predominantly are influenced by the impacts related to electricity generation, two additional scenarios were derived based on a publication of the German VDMA's group for power systems. Background of the scenarios is the increase of renewable energy sources, like wind and solar, for electricity generation. Therefore, the available EU27 power mix by thinkstep was modified according to the figures in **Table 22**.

“Classic” eco-design in context to the reference applications

The EU2030 scenario was derived based on the figures of the above-mentioned report, whereas the EU2050 is an own assumption of a potential further development of the electricity generation.

Table 22: Parameters of EU2030/50 power mixes in percentage of the total contribution per energy source.

	EU2030 (Source: VDMA power systems [VDMA, 2010])	EU2050 (own projection)
<i>Energy Source</i>	<i>Contribution [%]</i>	<i>Contribution [%]</i>
Biogas	4	8
Biomass solid	4	4
Coal gases	0	0
Hard coal	6.5	2.5
HFO (Oil)	2.5	2.5
Hydro	12	14
Lignite	7	3
Natural gas	16	12
Nuclear	19	15
Photovoltaics	5	8
Wind	23	30
WtE	1	1
<i>Additional parameters</i>		
Grid losses	4.35	4.35
Own consumption	1.39	1.39

**Figure 54** now displays the results of the life cycle impact assessment of Usage Scenario B) applying a EU27 grid mix (EU2015) adapted with the parameters of Table 6.

The results show that there is a significant reduction of the impacts associated with the electricity consumption through the increased contribution of renewable energy sources, but – even

for the EU2050 projection – the impacts associated with the manufacturing stage, as well as distribution and EoL stages, are still several orders of magnitude lower than those associated with the use stage. Hence, even up to 2050 improving efficiency will be an important point in the EU to reduce environmental impacts driven by electricity consumption.

For the further analysis, the environmental break-even for the exchange of an IE2 with an IE4 motor was calculated for the most relevant impacts by dividing the additional impacts of the motor with the higher efficiency at the materials, manufacturing, distribution and end-of-life stage through the savings in the use stage for the study’s base case. This is shown in **Figure 55**, in PE and GWP the time for the break-even increases when more of the electricity is generated from renewable sources.

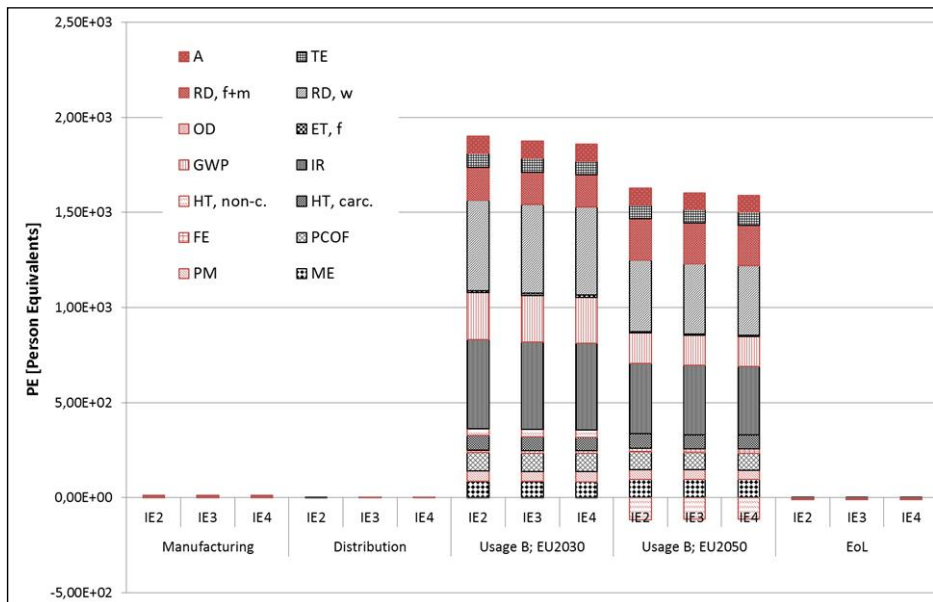

Figure 54: Normalized LCIA scores of motors with different efficiency classes in different electricity generation scenarios using the usage

“Classic” eco-design in context to the reference applications

Scenario B). Details to the scenarios are provided in Table 22 [JP-II].

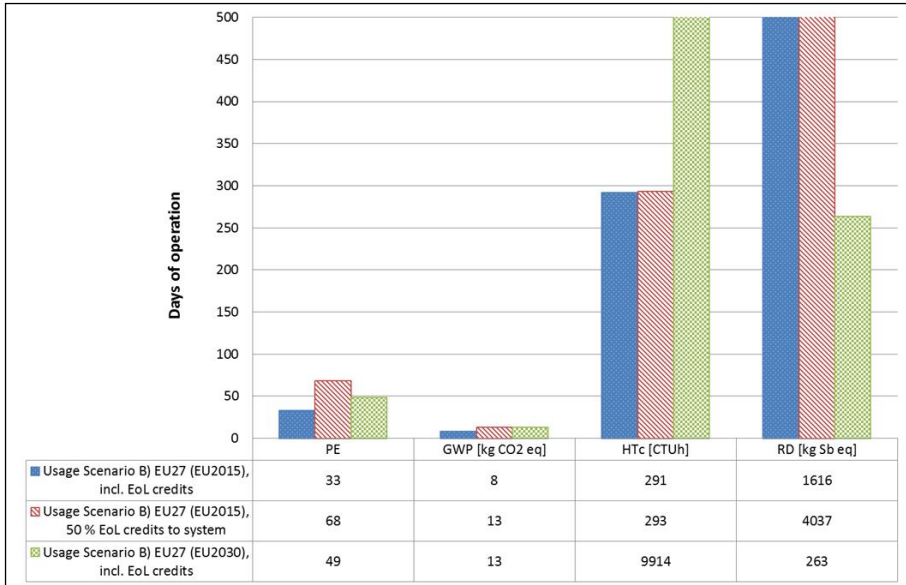

Figure 55: Environmental break-even calculation in days of operation, in normalized (PE) scores and in absolute figures in three different impact categories [JP-II].

#### 7.4.4 CONCLUSIONS

The normalized and weighted results of the comparative life cycle assessment case study on electric motors with different efficiency classes led to the conclusion that in the current technological set-up, especially concerning electricity generation and potential scenarios with higher contribution from renewable resources, any improvement in efficiency in the motor’s operation is environmentally beneficial, at least within the range of the usage scenarios applied in this study. This means that the trade-off between the life cycle stages is beneficial over the whole life cycle. Drilling this further down to the individual impact categories, a special behaviour was observed for human

toxicity (cancer effects), where the break-even between the additional effort for improving efficiency and the savings at use could only be reached after the assumed service life of the motor when more electricity is provided by renewable resources. Therefore managing this aspect will require special attention, especially considering the uncertainties and discussions underlying the available impact assessment methods, and decisions in ecodesign context should be taken carefully.

Currently it may lead decision makers in the wrong direction, especially when both: energy related impacts as well as the resource depletion of minerals and metals need to be managed. End-of-life treatment scenarios also have a high influence on this characterized impact through the crediting of the system under study with the benefits. This indicates that political initiatives as well as legislative acts tackling these issues have to bear that in mind or rather should improve the assessment methods before deciding and starting these initiatives to avoid burden shifting or a general dilemma. The study also showed the relevance of the load-time profile, indicated by the comparison between the two usage scenarios, and the motor's service life. Generally, the motors' efficiency is higher in a partial-load condition around 75 % of nominal power compared to the efficiency at 100 % load.

Another point in that context is generalization of the results of the study to other motor sizes (nominal power). Efficiency gains of motors with smaller nominal power, e.g. 11 kW, will be lower in absolute numbers, as well as the assumed service life be shorter (10-15 years), this could then lead to different results concerning the trade-offs or rather the environmental break-even of these impacts.

“Classic” eco-design in context to the reference applications

So when finally concluding on the deep dive into the trade-offs between life cycle stages in ecodesign context, it can be stated that these two aspects could be in the scope of further work to complete the picture of a relevant product category in an energy and material efficiency context.



## 8 “ECO-DESIGN 2.0” (APPLICATION-ORIENTED) STUDIES IN CONTEXT TO REFERENCE APPLICATIONS

### 8.1 GENERAL

The Energy related Products (ErP) Directive of the European Union [EU 2009] addresses products with a significant contribution (active or passive) to energy consumption in Europe. These products are assessed with a defined methodology in certain lots to evaluate potential improvements in terms of efficiency and to define the necessary measures. These are then regulated via so-called implementing measures in the form of EU regulations. One aspect of these implementing measures is the energy efficiency classes for electric motors introduced on the market from January 2015 [EC 2014a; EU 2014]. Associated with the implementing measures are harmonized European standards describing necessary procedures to ensure compliance with the regulation, for instance in terms of the measurement methods for energy efficiency determination [CLC 2014].

As laid out in the previous chapters (1 – 3) and stated in the section 4.1, as well as evaluated to some extent in section 7.4 (life cycle assessment of motors with different efficiency classes), one point often not considered and/or not addressed in terms of energy efficiency is the aspect of application within a system, whereas previous case studies and other research work showed the importance of system design regarding environmental and economic performance. For instance do electric motors placed on the EU market have to comply with



energy efficiency class IE3 or IE2 when operated with a variable speed drive (VSD), but operating a fixed-speed application with a VSD just generates additional losses compared to directly networked operation with starters and contactors, whereas for variable speed applications, for instance in certain pumps and ventilation systems, the VSD can really improve efficiency [Thomas 2012].

In order to guide and support practitioners, the European standardisation organization CENELEC was commissioned by the European Commission to set out harmonized standards for the eco design and efficiency determination of drive systems (M/470, M/476) [CLC 2014]. Within CENELEC, the technical committee TC22X for power drive systems, working in close collaboration with other technical committees involved with the directive, regulations and the associated, harmonized standards (such as TC17B, TC2 and CEN TC197) has elaborated a new family of standards, the EN50598 “Ecodesign for power drive systems, motor starters, power electronics & their driven equipment”, which was issued in January 2015. The standard applies to drive systems in the power range from 0.12 kW up to 1000 kW and consists of three parts:

- [EN50598-1:2015] describes the extended product approach (EPA) to derive energy efficiency indicators (EEI) using semi analytical models (SAM) and the requirements which must be met to apply this approach to drive applications;
- [EN50598-2:2015] standardizes the efficiency determination of frequency converters and their driven applications;

“Eco-design 2.0” (application-oriented) studies in context to reference applications

- [EN50598-3:2015] describes the application of a qualitative and quantitative eco-design process, including product category rules for life cycle assessments and the content of environmental declarations.

Now in the further, the concept of the EPA can be pretty much seen as a key for approaching the interface of applications to systems (solutions) and the SAM as a key for the interface of a given system to its components. This issue, i.e. proper definitions of the interfaces between the elements “application”, “system” and “components”, often also is an issue in LCA case studies and corresponding environmental declaration schemes, for decision support. Therefore, the EPA and SAM can be seen as a key for approaching the concept of the functional unit (FU) originating from LCA. As a test of this idea, this case study was set up to evaluate potential environmental and economic benefits by means of LCA and LCC, combined in the Siemens Eco-Care-Matrix. In this case study, two drive systems were evaluated in context of two pump application scenarios, differentiated by their operating profiles, comparing both economic and environmental performance. Main purpose of this chapter is to (i) to explain the EPA approach and (ii) to test it in an eco-efficiency approach.

Subsequently, the main aspects of the EN50598 standard are described, including the bridge from the concept of the EPA to the FU in LCA. After this, the results of the corresponding eco-efficiency case study we conducted in order to test the concept are presented.

## 8.2 EXTENDED PRODUCT APPROACH

### 8.2.1 GENERAL

As stated above, the EN50598-1 specifies a methodology to determine the energy efficiency index (EEI) of an application, based on the concept of semi-analytical models (SAM). The methodology is called the extended product approach, EPA. It enables product committees for driven equipment (i.e. the extended product – EP) with included motor systems, to work with the relative power losses of the included motor system in order to calculate the overall system energy efficiency aspects for the extended product. The extended product and its components are illustrated in **Figure 56**.

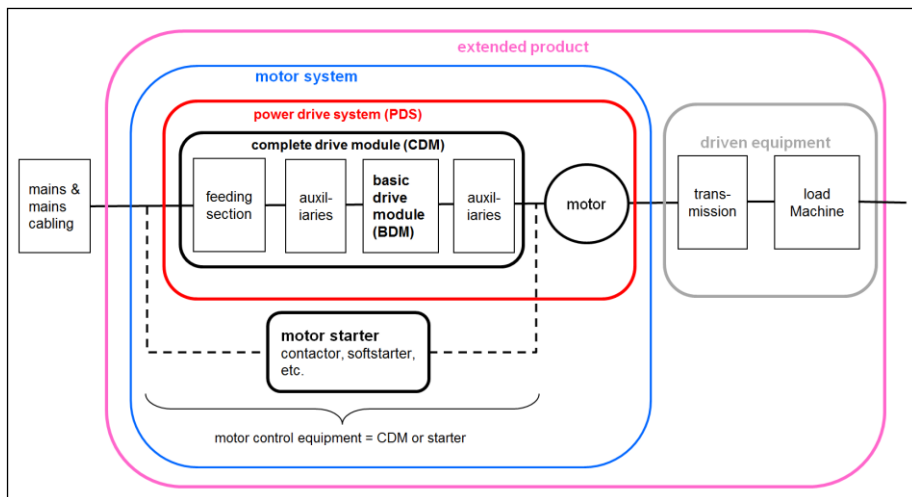

Figure 56: The extended product (EP) is defined as the motor system and the driven application. The motor system is defined as a power drive system (PDS – complete drive module and motor) or motor starter and motor [C-II].

A key necessity articulated and operationalised in EN 50598, which was not addressed in former standards, is that the system energy efficiency calculation has to be based on specific calculation models for speed/load profiles, load-time profiles and the relative power losses of appropriate torque versus speed operating points. The standard also specifies the tasks and responsibilities of the different stakeholders in creating or using these extended product standards.

### 8.2.2 WORKFLOW AND REQUIREMENTS FOR THE SEMI-ANALYTICAL MODEL (SAM)

The determination model for the losses or the energy efficiency index of an extended product is called the SAM, which includes physical and mathematical parameters and calculation algorithms of the subparts of an EP.

**Figure 57** illustrates the application of the EPA including the tasks to be performed by affected stakeholders. It also visualizes the complexity and need for collaboration of the involved stakeholders and the need for a harmonized approach (e.g. consistency between the standards produced by different technical committees) through standardisation.

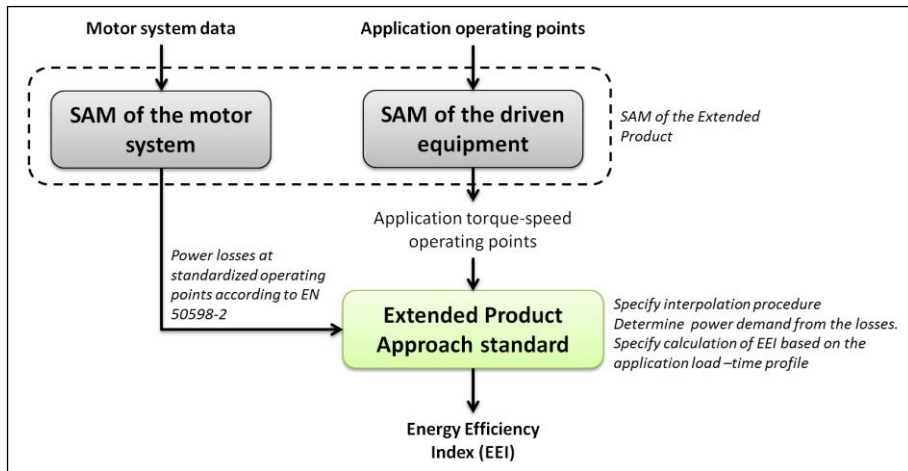

Figure 57: Illustration of the workflow for application of the EPA based on SAM [C-II].

**Figure 57** also shows how the SAM of the motor system (left-hand side) is linked to the SAM of the driven equipment (right hand side). The links in-between both semi analytical models are the load loss points of the motor system (e.g. PDS) and their permissible tolerances. The actually required operating points have to be defined by the semi analytical model of the driven equipment.

The motor system data (including the specific SAM) containing the losses (e.g. PDS, PDS losses) is defined in EN50598-2, whereas the semi analytical energy consumption models of the PDS-driven application (right-hand side of Figure 2) have to be drafted by their responsible product committees using the same approach. **Figure 58** shows how the different data sources have to be combined.

“Eco-design 2.0” (application-oriented) studies in context to reference applications

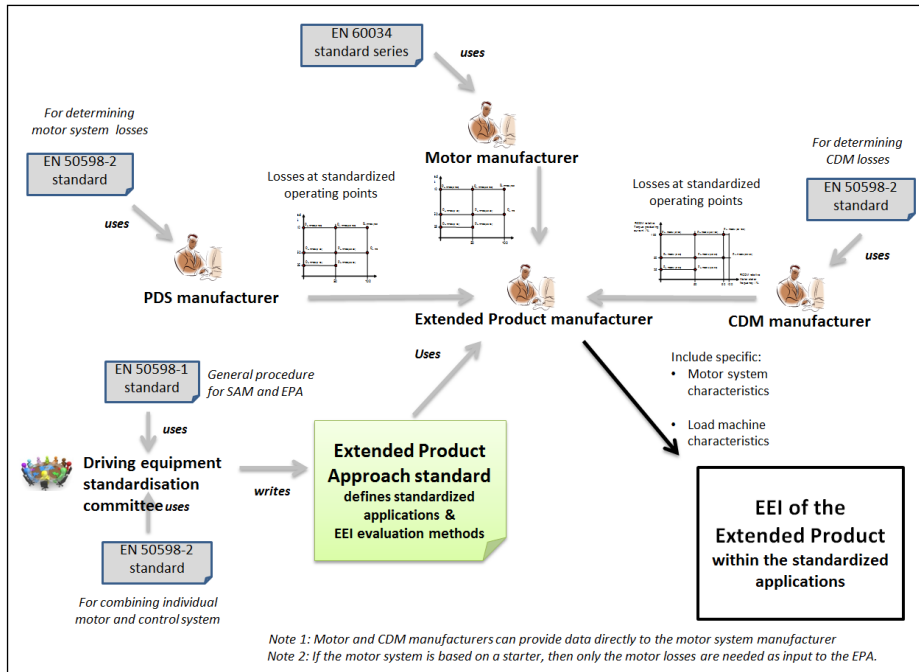

Figure 58: Illustration of the different stakeholders affected by standardized determination of the energy efficiency index for extended products, such as driven applications, by combining data from different sources [C-II].

It is the responsibility of the technical committees for specific applications to standardize publicly available SAMs for their applications.

The SAMs for the subparts of the extended product are necessary in order to determine the overall power losses of the extended product. The outcome of the SAM, considering the most relevant energy efficiency aspects of all components of the system, can be used to calculate the energy efficiency index (EEI). This index then allows a quantitative distinction to be made between

efficient and inefficient solutions for an application for which the extended product can be used. This EEI value therefore has to be provided by the manufacturer in a metric scheme, for instance in the user's documentation or the catalogue.

### 8.2.3 SAM MAIN CHARACTERISTICS

The energy savings that can be achieved, or in other words the design of the most efficient system for a certain application, often depends on the operating point (OP) at which the extended product is operated. Two application-related characteristics, the torque or power versus speed profile and load-time profile, are particularly useful for describing the extended product and the way it is operated. These two characteristics can be used as input data to derive the right motor control equipment of the extended product in terms of energy efficiency performance.

#### 8.2.3.1 THE TORQUE OR POWER VERSUS SPEED PROFILE

This profile describes how the torque required by the driven equipment depends on its speed. It essentially depends on the type of driven equipment. The torque or power versus speed profile describes how the torque  $T$  or power  $P$  required by the driven load varies with its speed  $n$ . The power is also the product of torque and speed.

Most existing driven equipment can be categorised into one of the basic torque and power vs speed profiles shown in **Figure 59**.

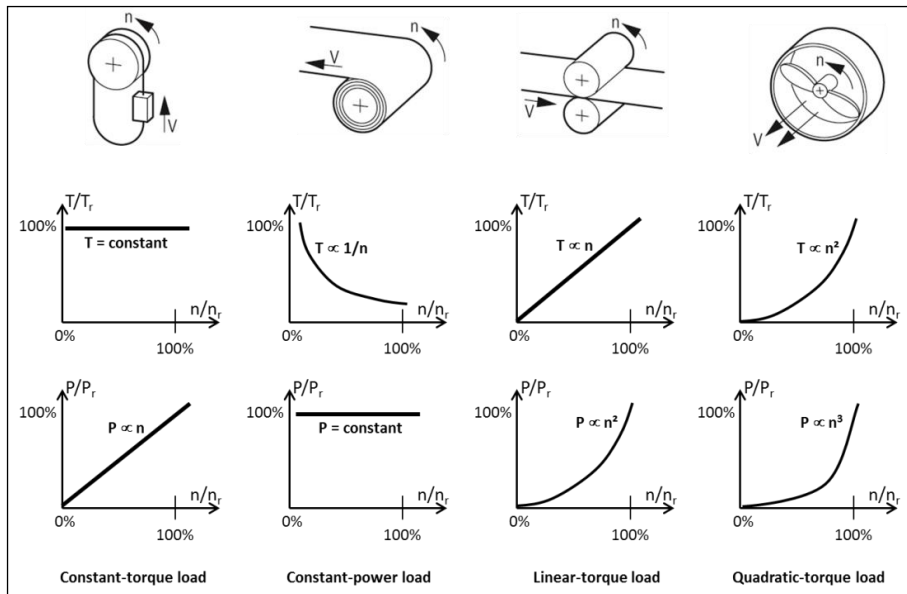

Figure 59: Typical torque/power vs. speed profiles for different extended products [C-II].

### 8.2.3.2 THE LOAD-TIME PROFILE

This profile describes the various power levels required by the driven equipment, including standby, and the fraction of time during which the equipment is operated at these levels. The load-time profile essentially influences the sizing of the motor system and how the extended product is operated in practice.

The desired behaviour of the extended product, as well as the characteristics of the motor, is defined by one or more operating points at which the motor will have to be operated. Depending on the process demands, the motor may not be running at rated output power all the time. Part load is a situation where the application requires reduced torque and/or speed compared to the rated values.



The efficiency of an extended product heavily depends on the load level. Furthermore, stand-by (SB) losses of soft starters and CDMs have to be considered. They are present in periods where the power section is disabled but the control is still supplied. Standby losses are losses generated, for example, by the power supply of the control section. To estimate the efficiency of an extended product and compare several potential control solutions, it is therefore essential to know which levels of mechanical and electrical power are needed by the extended product and in which time fraction.

To calculate the electrical energy needed, the individual required electrical power supplies have to be multiplied by their time span. Time fractions in percentage terms have to be based on the whole operating time over one productive year of the installation. An example of operating points over time is shown in **Figure 60**.

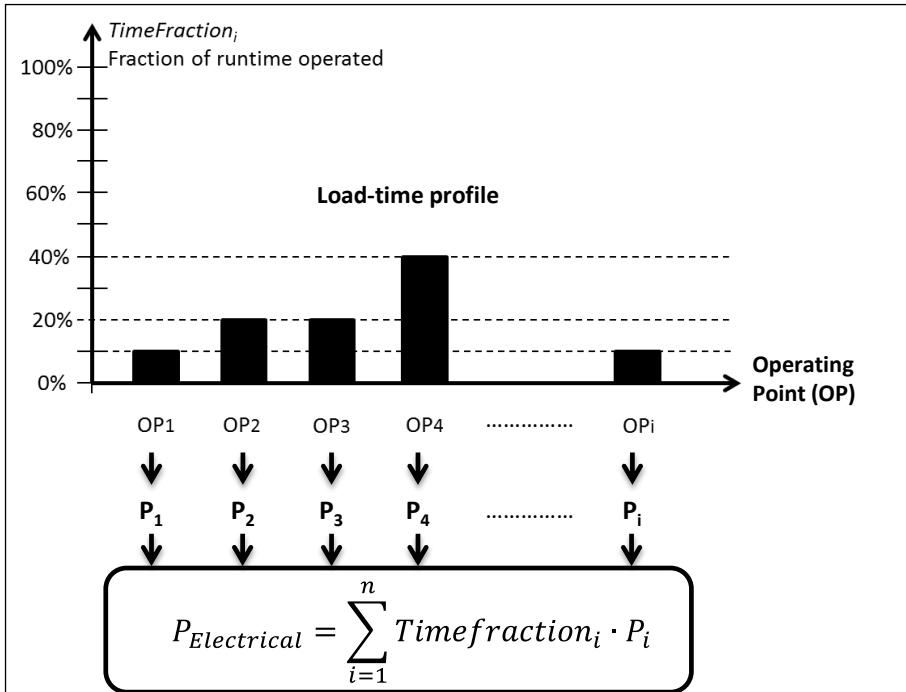

Figure 60: Typical power required by application over time fraction = load-time profile required to calculate the electrical energy needed [C-II].

The duty profile describes the requirements of the extended product in terms of mechanical power. For each Operating Point  $OP_i$ , the electrical power  $P_i$  that must be supplied by the mains depends on the mechanical power and the overall extended product losses (or equivalently its efficiency) at this level.

The weighted average electrical power  $P_{electrical}$  required to run the extended product as desired is:

$$P_{Electrical} = \sum_{i=1}^n (Timefraction_i \cdot P_i) \tag{1}$$

The weighted average electrical power is directly relative to the electrical energy consumption (in e.g. kWh) required by the extended product during a certain runtime period:

$$E_{\text{Electrical}} = P_{\text{Electrical}} \cdot \text{Runtime} \quad (2)$$

The weighted average electrical power (or equivalently electrical energy) can be calculated for several potential control strategies suitable for the extended product (e.g. switchgear and CDM) and this information used to choose the most efficient one.

#### 8.2.4 APPLICATION OF THE EXTENDED PRODUCT APPROACH (EPA)

As stated above, application of the EPA including the (individual) SAMs to determine the EEI of an extended product relies heavily on the collaboration of the involved stakeholders. The EPA itself is basically the combination of the SAMs of the involved (required) system components as regards the application.

The basic steps that consequently have to be taken by the extended product (driven system, application) technical committees are the following:

- specification and standardisation of one (or more) torque versus speed and load-time profiles, considering typical loads and service conditions
- definition of an SAM for the extended product based on the eight operating points (torque versus speed) specified in EN50598-2,

“Eco-design 2.0” (application-oriented) studies in context to reference applications

- if necessary, definition of an appropriate method to determine losses at intermediate operating points,
- Specification of a method to derive an EEI (including tolerances) for the extended product.

These steps are summarized in **Table 23** including the relevant inputs and outputs.

Table 23: Basic steps from a SAM to an EEI via EPA.

	<i>Input</i>	<i>Output</i>
SAM Motor System (MS)	Motor system characteristics (physical components, rated power...)	Losses of MS at standardized operating points
SAM Extended Product (EP)	Output of SAM MS + characteristics of EP	Losses of EP at standardized operating points
Extended Product Approach	Output of SAM EP + requirements relating to the application (load-time profiles, operating time...)	Energy efficiency index of EP for the application

The EPA is consequently a merger of two (or more) SAMs based upon a set of relative losses at a determined torque/power versus speed operating points and a load profile of the driven equipment.

This links directly to the concept of the functional unit in life cycle assessment, as it provides a standardized approach to the description of the interface between the application to the underlying (motor) system and its included components. Hence, it can be seen as a key enabler to performance evaluations like eco-efficiency tools, e.g. Eco-Care-Matrix, utilizing results from LCA and LCC. **Figure 61** visualizes this idea.

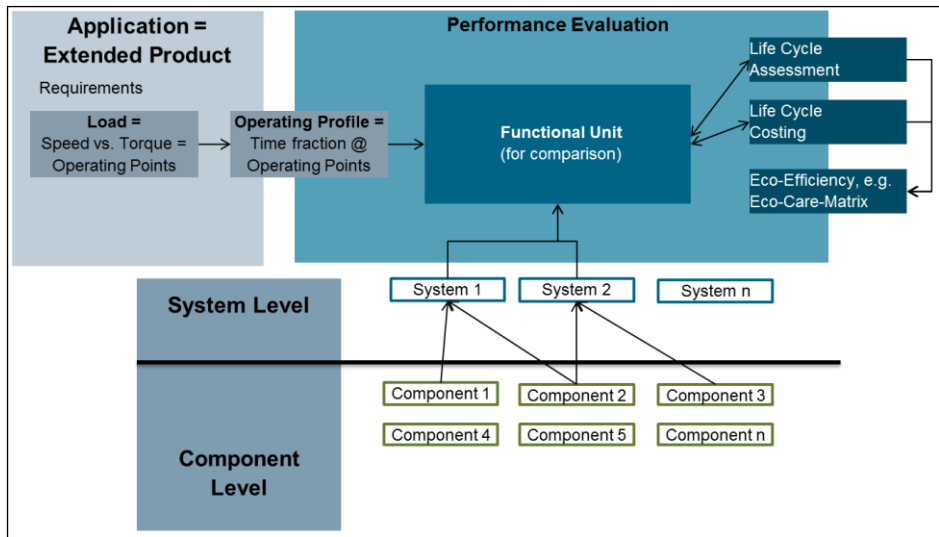

Figure 61: Graphical display on how the EPA can be seen as a key enabler to performance evaluations like Life Cycle Assessment, Life Cycle Costing and Eco-Efficiency assessments, like the Eco-Care-Matrix [JP-III].

### 8.2.5 CLASSIFICATION OF FREQUENCY CONVERTERS AND POWER DRIVE SYSTEMS

This part of the standards family, the EN 50598-2, basically applies the EPA to drive systems and standardizes the EEI (IE- and IES classes). It also standardizes the calculation and test procedure for losses, including losses of reference components (such as reference PDS, CDM and loads/motor) and the mathematical model for their calculation.

The losses of a PDS (complete drive module and motor) depend largely on operating points (as well as ultimately the load profile – see section 8.2.3). To minimize the effort required, eight operating points were defined at which losses have to be determined by the respective manufacturer. These are displayed in **Figure 62**.

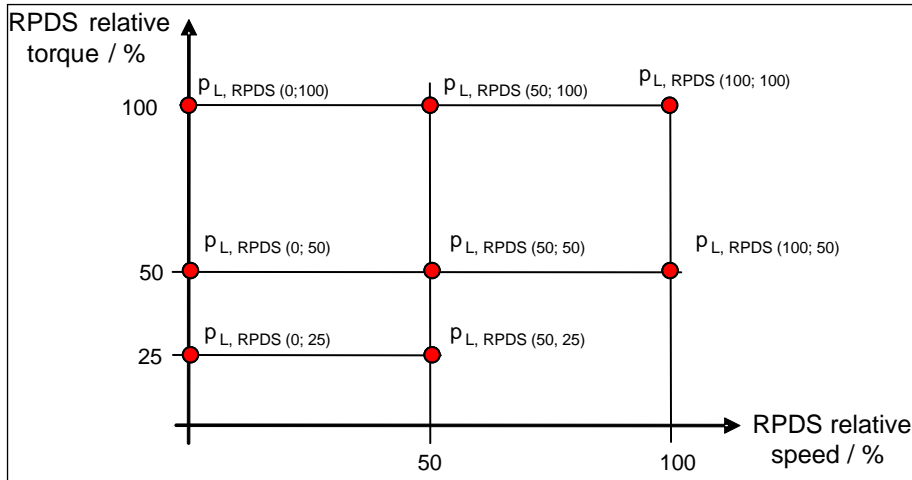

Figure 62: Operating points for loss determination of power drive systems [C-II].

Since a frequency converter has no speed or torque, the relative output frequency (modulation) and the relative current corresponding to the operating point are used for loss determination in this case. These are displayed in **Figure 63**.

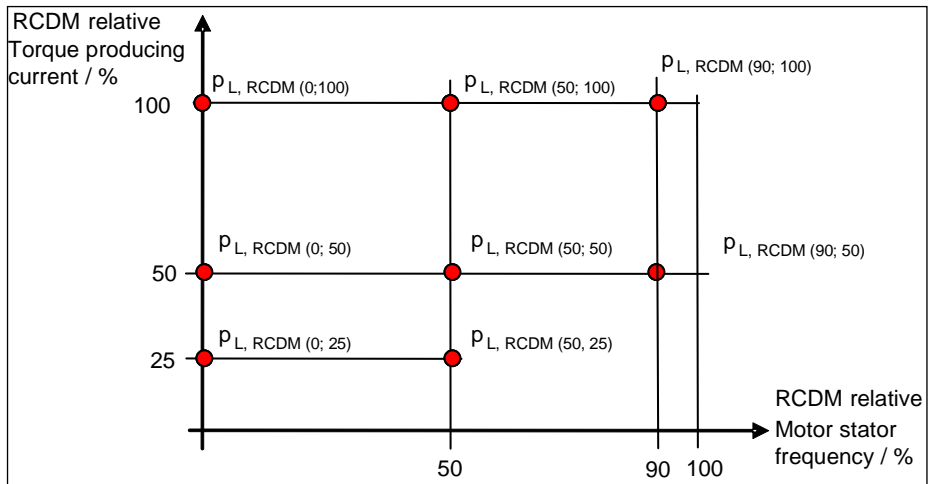

Figure 63: Operating points for loss determination of frequency converters (complete drive module) [C-II].

As well as the nominal operating points, seven further part load points are defined in the standard, allowing a determination of losses by linear interpolation or extrapolation within the first quarter of the diagram.

To determine losses at the rated operating point, a control factor of 90 % is set to avoid over-modulation. Otherwise, the control factors of the frequency converters correspond to the operating points of the drive system. Some of these operating points are at very low speeds with output power at almost zero, as well as efficiency, independently of high or low losses. Losses are consequently the leading indicator of drive system performance in these cases.

The losses of frequency converter and power drive systems determined in this way enable users, e.g. in pump applications, to determine the most efficient solution for their system via the EPA, as explained in section 8.2.4, using a SAM.

“Eco-design 2.0” (application-oriented) studies in context to reference applications

Additionally, these losses form the basis for the comparable classification of frequency converters as well as drive systems according to IE classes (International Efficiency). For motors (low voltage standard motors), these have already been defined in [IEC 60034-30-1]. For frequency converters, classification is carried out through comparison to a reference device, which is defined in the standard as a “state of the art” 3-phase voltage source inverter with 2-level technology and a nominal voltage of 400V. To evaluate the IE class of the frequency converter, losses are determined at 90 % control factor (corresponding to 100 % torque building current) and compared to the losses of the reference device. If losses are approximately the same ( $\pm 25\%$ ), the converter is rated IE1. If losses are lower, it is rated IE2 and in the case that losses are higher, it has to be rated as IE0, in either case more than the standardized tolerance of 25 %.

For drive systems, determination of the IES-class (International Efficiency for Systems) works basically the same way. IES1 covers the range of  $\pm 20\%$  of losses in a reference drive system. This is illustrated in **Figure 64**.



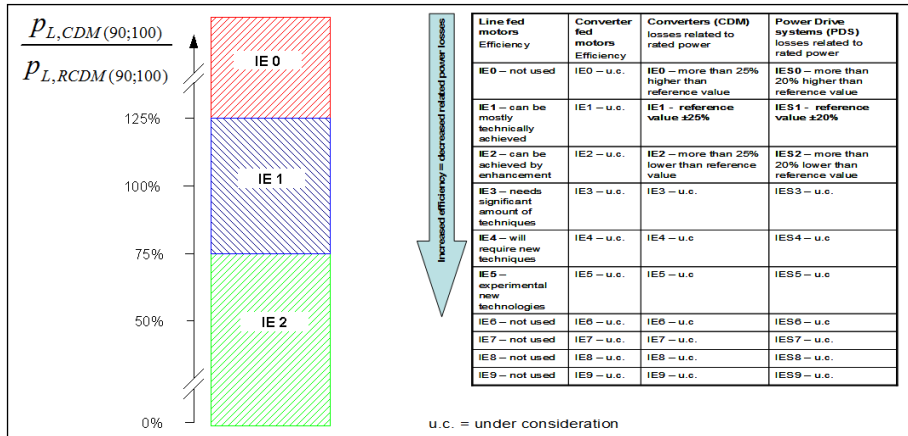

Figure 64: Illustration of IE class evaluation of frequency converters and drive systems [C-II].

## 8.2.6 THE DEFINITION OF AN ECO-DESIGN PROCESS, INCLUDING PRODUCT CATEGORY RULES FOR LIFE CYCLE ASSESSMENTS AND THE CONTENT OF ENVIRONMENTAL PRODUCT DECLARATIONS

This third part of EN 50598 specifies the process and requirements for implementing environmentally conscious product design principles (ECD), for evaluating ecodesign performance and for communicating potential environmental impacts of power electronics (e.g. complete drive modules, CDM), power drive systems and motor starters, all used for motor-driven equipment in the power range of 0.12 kW up to 1000 kW and low voltage (up to 1000 V) applications over their whole life cycle.

It defines the content for two different environmental declarations based on EN ISO 14021:

- **The basic version**, which will be referred to in this context as environmental declaration type II, with basic data and qualitative statements on eco-design;

“Eco-design 2.0” (application-oriented) studies in context to reference applications

- **The full version**, which will be referred to in this context as environmental declaration type II+, based on a life cycle assessment and including quantitatively evaluated potential environmental impacts. Here, the general principles of EN ISO 14025 are taken into account and product category rules [PCR] for motor system components are included to ensure a harmonized approach. For fully complying with ISO 14025 a third party environmental program, including the necessary verification process, has to be joined.

An environmentally conscious design process culminates in a declaration of the potential environmental impacts or environmental claims of the components of a motor system in an environmental declaration or footprint.

ECD requires the identification, measurement and reporting of particular impacts. IEC 62430 describes the principles of ECD with the goal of reducing the potential environmental impacts of products and is referred to in the EN50598-3 standard.

As mentioned before, the standard leaves the manufacturer two choices (basic: qualitative; full: quantitative) on how to approach and implement ECD. The process itself has to be described in the manufacturer’s (design) process instructions and if possible should be integrated into the management system (e.g. ISO 14001 or 9001) of the company. If the ECD is an integral part of a certified management system, third party verification through the certification audits is assured. If the manufacturer has no certified management system, the assurance of verification must be provided by internal audits.

This is the basic qualitative approach. It requires manufacturers to identify the main environmental issues of their products and to define appropriate improvement strategies in the context of factors such as energy efficiency, material usage (e.g. legislative requirements) and recyclability. This can be done, for instance, by adding these topics and strategies to the product requirement and feature specifications and by involving relevant functions such as environmental specialists in the design process. Benefits for manufacturers include a systematic approach to all relevant environmental and compliance issues, e.g. substance legislation such as RoHS, or other directives such as WEEE. The outcome can also be used for qualitative environmental statements on the product level, in context of this standard as a basic environmental declaration referring to ISO 14021 type II environmental declarations.

In addition to the principles of the basic approach, a life cycle assessment provides the possibility to quantify the ECD. By quantification, manufacturers can be sure of really focusing on the most relevant environmental issues and of quantifying improvements in terms of a reduction of, for instance, CO<sub>2</sub> emissions. Since an LCA requires a large amount of work, a smart approach is the key to ensure efficient implementation. For instance, manufacturers can define product families and assess these using selected key products. If these product families are homogeneous in terms of the manufacturing technologies and material composition used, potential environmental impacts can then even be approximated using linear regression. In case of a full ECD approach using an LCA, the data can also be used for full environmental declarations as defined by the standard,

“Eco-design 2.0” (application-oriented) studies in context to reference applications

provided the standardized product category rules (PCR) are applied.

For LCA-based environmental declarations, the standard defines PCRs (according to ISO 14025) for motor systems and their components. The standard is divided into basic PCRs (core PCRs), common and basic rules for all components of the drive system and further product-specific rules (PSR), e.g. for converters, starters etc. The PSRs are designed to allow further product-specific simplification of the LCA, e.g. through differentiation between main components, involving mandatory consideration, and auxiliary components, where consideration is voluntary due to low significance. These rules have to be applied in the LCA if the results are meant for external communication. They define certain parameters for all manufacturers to enhance the comparability and usability (in a system context) of declarations.

## 8.2.7 DISCUSSION & CONCLUSIONS

This section explains with the 2015-released European standard EN 50598 on energy-efficiency of drive systems. It defines an innovative approach to energy efficiency determination for converters and especially for drive systems in an application context through semi analytical models and the extended product approach. Manufacturers of power drive systems now have to evaluate losses at eight defined operating points and use the corresponding energy efficiency index. This information then has to be provided with the product documentation. System designers are then able to define the most efficient drive solution to the need of the application based on the operating points and the associated losses.

Hence, this standard particularly addresses the very important but in previous standardisation not covered aspect, that energy-efficiency should be assessed in application context and of complete drive systems, under an Extended Product Approach (EPA), and not “just” based on energy-efficiency of single components of the drive system, e.g. single motors, since system efficiency in applications cannot be deducted from efficiencies of single components, no matter how well such “classic” single-component approaches and related efficiencies may be described and standardized. For actually applying the EPA, key support elements provided by the standard are the concepts of load-time profiles and of operating points, at which the drive systems work in operation.

Completing this with the research background of ecodesign and the current state-of-the-art of implementation it can be underlined that the matter of ecodesign and standardisation is very multifaceted. Thus, it yields several aspects potentially worth-while a discussion related to the EPA, for instance harmonization of horizontal (generic, cross-category) standards and vertical (specific, single-category) ones, or how to address electronic products (following their own standardisation paradigm), which are part of non-electronic products (following a different standardisation).

The EPA as such adds complexity to the task as it advocates (i) taking an extended scope of what is to be analysed and (ii) judging upon this in various application situations. Compared to earlier practice, this means more efforts for the practitioner, e.g. due to more data collection covering all elements of the larger system. Putting this into the various application situations requires additional extra time. However, the guidance given in

186

“Eco-design 2.0” (application-oriented) studies in context to reference applications

the standard seems to be clear and comprehensive enough to work with, and component manufacturers in Europe are obliged to provide the necessary data in their manuals, hence the additional effort should decrease after a certain run-in phase at the practitioner's side. Most importantly, the overall somewhat higher effort from taking the EPA is fully justified by its very purpose as it enables decision-making in the appropriate larger context and thus eliminates common issues such as sub-optimisations (i.e. improvements of sub-parts of the system, which may be insignificant or even counterproductive in the larger system context). And providing such a larger context will, per se, always require more data and related efforts.

The standard also defines requirements for qualitative and quantitative environmentally conscious design processes and environmental product declarations. Furthermore, the standard introduces an LCA-based environmental self-declaration type, based on ISO 14021 and taking into account the basic requirements of ISO 14025, and defines product category rules for this. This holistic approach, from the initial ECD to the EPD, utilizing and further detailing applicable horizontal standards from both the IEC and the ISO worlds of standards is also quite new in product standardisation of electronic and electrotechnical products and systems. The formulation of PCR, especially in the contemporary discussions and developments on environmental footprints of products (e.g. the European PEF initiative), can be a robust foundation to the harmonization of these rules, because different EPD program operators (as required by the ISO 14025 for full type III environmental declarations) or other institutions can rely on them, and manufacturers therefore would be able to

participate in these without having to adapt their underlying LCA models and accompanying reports. Manufacturers can choose their approach, or rather, can detail the corresponding processes according to their needs and strategy.

A corresponding eco-efficiency case study of drive systems in application context was conducted, utilising the EPA and is described in the next chapter.

## 8.3 DRIVE SYSTEM FOR PUMP APPLICATION

### 8.3.1 GOAL, SCOPE & LIFE CYCLE INVENTORY

Examining the environmental and economic performance of two drive systems in two application scenarios (in terms of an operating profile) is the goal of this case study.

Drive system 1 is a fixed-speed drive system and drive system 2 is a variable-speed drive system. Both drive systems consist of products within the Siemens product catalogue. Based on the lifetime of the frequency converter, the assumed lifetime of both drive systems is 15 years; both drive systems are manufactured and used within Germany.

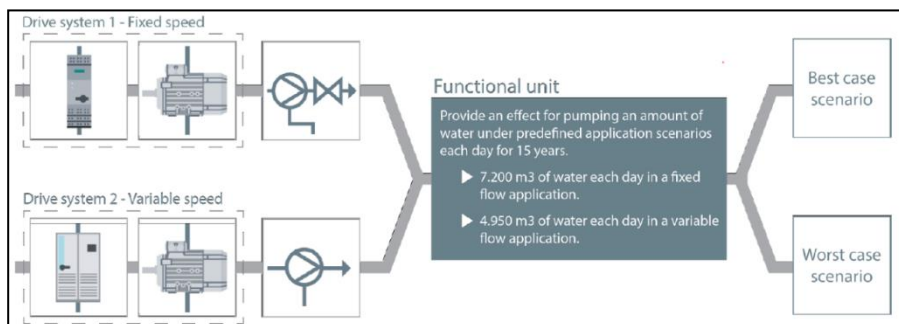

Figure 65: Graphical display of the case study concept including the defined functional units [JP-III]

“Eco-design 2.0” (application-oriented) studies in context to reference applications

One application scenario is tested for a constant flow of 100%, while the other application scenario represents a variable flow of a pump. Drive system 1 with the fixed speed has an additional throttle to be able to control the flow from the pump. This is not necessary for drive system 2, since it already has a variable flow. As the pump, the throttle is also placed outside of the system boundary. The settings of the pump application with the medium water were a pump head of 100 m (1 stage) and a flow rate of 300 m<sup>3</sup>/h, hence a nominal power of 132 kW has to be provided by the drive system.

For both scenarios, the reference profile is assumed as 365 days and 24 hours of operation per day. The details in terms of operating hours at a specific flowrate are shown in **Table 24**, the set-up/concept including the functional unit in **Figure 65**.

Table 24: Two operation scenarios for pump applications in terms of operating hours per flowrate. This reference scenarios are basis for the case study. For both the reference service life is 15 years, operating at 365 days per year and 24 hours per day.

	<i>Flowrate [%]</i>	10	20	30	40	50	60	70	80	90	100
1) Fixed Speed	Operating hours	0	0	0	0	0	0	0	0	0	24
2) Variable Speed	Operating hours	0	0	1	2	3	5	5	4	3	1

The corresponding functional unit chosen is:

- 7.200 m<sup>3</sup> of water each day in a fixed flow application
- 4.950 m<sup>3</sup> of water each day in a variable flow application



In this case study SimaPro was used for the modelling of the material, manufacturing and disposal stage, if materials were differently defined or did not exist in the library, estimates were applied. The scope was determined from the extraction of raw materials to the disposal stage. **Figure 66** exemplarily shows the modelling approach taken, and **Figure 67** shows the associated system boundaries for the drive systems by the model for drive system 1. The model will be similar for drive system 2, only substituting the soft starter with the frequency converter.

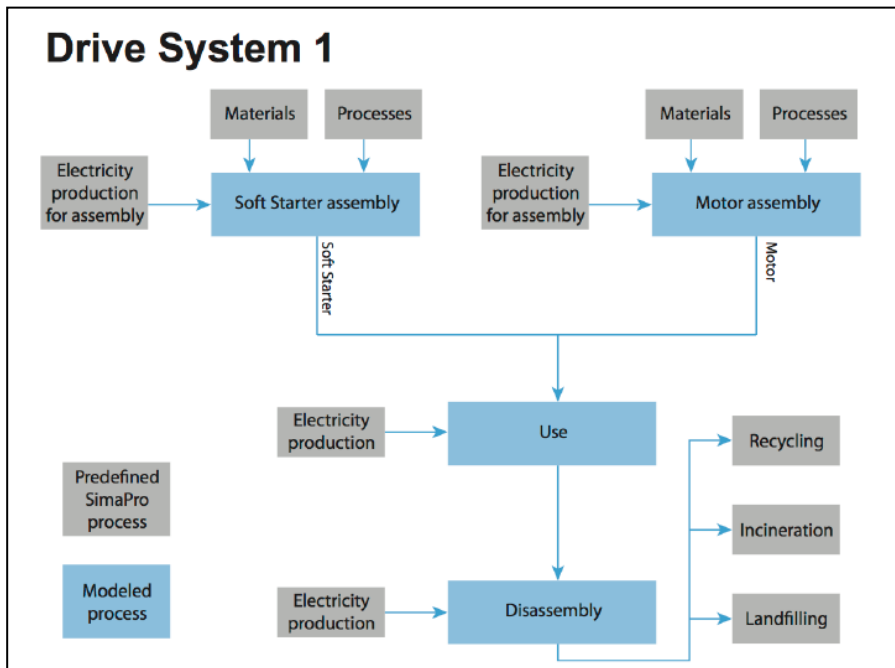

Figure 66: Modelling network exemplarily shown for drive system 1 [JP-III].

The processes are divided into foreground processes (foreground system) and upstream- and downstream processes (background system). Regarding transport, all other transportation processes in the LCA have been neglected, except the ones already

“Eco-design 2.0” (application-oriented) studies in context to reference applications

included in the generic data sets of the selected materials and processes in the background system.

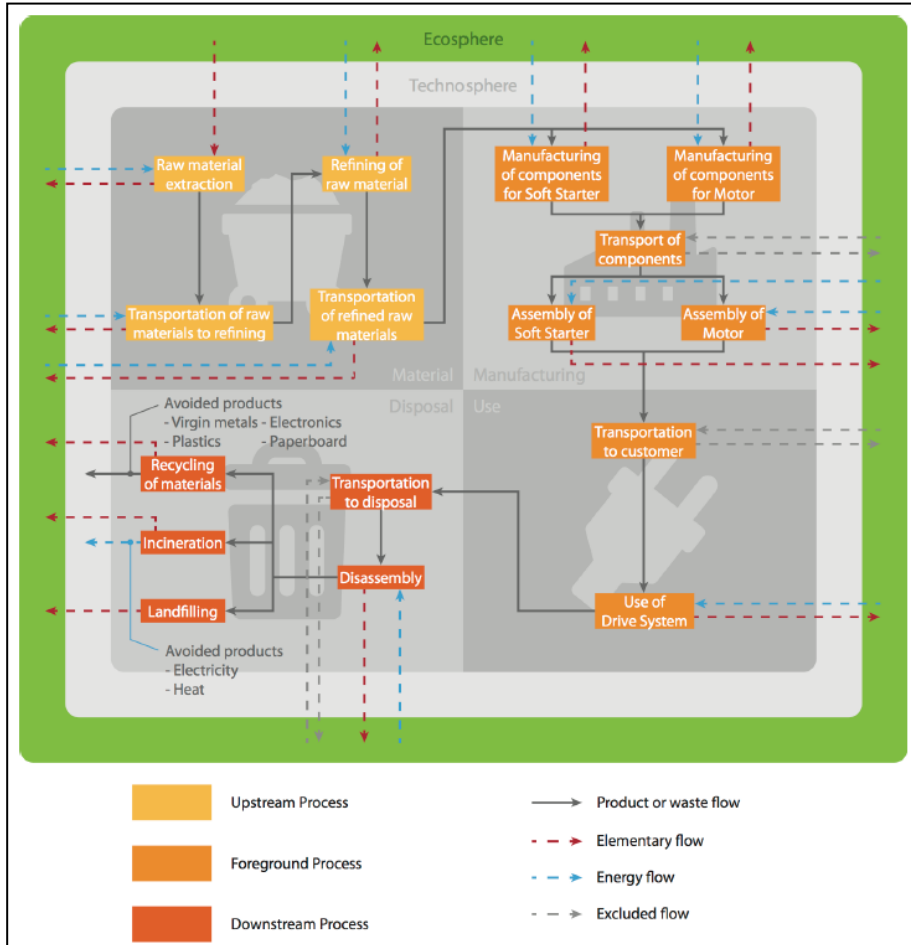

Figure 67: Model showing the system boundaries [JP-III].

To simplify the modelling of the drive system components, a 1 % weight based cut-off was applied. A bill of material (BoM) which includes weight and material was provided by Siemens. In the SimaPro model the processes of material and manufacturing are predefined in the Ecoinvent database. The energy

consumption for assembly is assumed to be the same as for the frequency converter (scaled according to weight).

Also based on a 1% weight cut-off, five out of 14 materials are considered to be significant for the *motor*. The manufacturing processes are assumed, based on the most conventional process for each material. The received data is valid for a 110 kW motor, and then scaled up to a 132 kW motor. For the frequency converter there has been no modelling because the received data is already processed and provided as impact scores with the ILCD 2011 Midpoint+ method.

The processes for end of life treatment have been chosen on the basis of common practices in Europe as reflected in the database of SimaPro.

The modelling in SimaPro, makes use of the Ecoinvent consequential system and unit version 3.0.1 library and the ILCD 2011 Midpoint + version 1.06. The impact categories that are included in this method, as well as the normalisation factors are presented in **Table 25**.

“Eco-design 2.0” (application-oriented) studies in context to reference applications

Table 25: Impact categories of ILCD 2011 Midpoint + version 1.06 with units and Normalisation factors.

Impact Category	Units	Normalisation Factors
Climate Change	kgCO2-eq	1.1E-04
Ozone Depletion	kgFC-11	4.63E+01
Human Toxicity (cancer)	CTUh	2.71E+04
Human Toxicity (non-cancer)	CTUh	1.88E+03
Ionizing radiation HH	kg PM2.5-eq	8.85E-04
Ionizing radiation E	kgBq U235-eq	0
Photochemical Ozone Formation	kg NMVOC-eq	3.15E-02
Acidification	molc H+eq	2.11E-02
Terrestrial eutrophication	molc N-eq	5.68E-03
Freshwater eutrophication	kg P-eq	6.76E-01
Marine eutrophication	kg N-eq	5.92E-02
Freshwater ecotoxicity	CTU-e	1.14E-04
Land use	kg C deficit	1.34E-05
Water resource depletion	m3 water eq	1.23E-02
Mineral, fossil & renewable resource depletion	kg Sb eq	9.9E00

As tool for calculating the power demand of the two drive systems in the two application scenarios SinaSave is utilized. In order to compare the two drive systems the required specifications have to be entered to demonstrate energy savings and CO<sub>2</sub> emission savings. The calculated power demand is used as input in SimaPro and corresponds to the electricity consumed in the use stage. For the LCC, SinaSave was used too, reflecting current market prices for the systems set-ups. The integrated drive systems' components prices are current list prices (March 2017), energy cost is set to 0.12 €/kWh. Investment costs were assumed to be dominated by the cost for the components (e.g. motors) and therefore installation costs, as well as cost for

maintenance, are expected to be comparable (no major difference between the systems) and are therefore not included.

## 8.3.2 RESULTS

### 8.3.2.1 LIFE CYCLE IMPACT ASSESSMENT

**Table 26** shows the calculated power demand of the two drive systems in the two defined application scenarios and gives already an impression of the performance in terms of comparison of their power demands. This is the foundation for assessing the use stage in the LCA, as well as the operating cost (OPEX) in the LCC.

“Eco-design 2.0” (application-oriented) studies in context to reference applications

Table 26: Energy Consumption of the two drive systems in the applied usage scenarios (fixed speed, variable speed) per year and for the assumed service life of 15 years. Drive system 1, as basis for calculating the energy savings, is equipped with a soft starter and a throttle, drive system 2 with a variable speed drive.

		<i>Drive System 1: Fixed Speed Drive with IE3-Motor (FSD-IE3)</i>	<i>Drive-System 2: Variable Speed Drive with IE3-Motor (VSD-IE3)</i>
<i>Application Scenario 1: Constant flow, fixed speed</i>	Power Demand per year [kWh/a]	925,959	945,999
	Power Demand for 15 years [MWh]	13,889	14,190
	Difference in 15 years (DS1 – DS2) [MWh]	<b>- 300</b> → DS1 performs better in this scenario	
<i>Application Scenario 2: Variable flow, variable speed</i>	Power Demand per year [kWh/a]	672,863	358,461
	Power Demand for 15 years [MWh]	10,092.9	5,376.9
	Difference in 15 years (DS1 – DS2) [MWh]	<b>+ 4,716</b> → DS2 performs better in this scenario	

**Figure 68** now displays the external normalized scores in Person Equivalents (PE). The impact assessment shows that the impact categories with the highest impact scores are human toxicity (non-cancer effects), climate change and freshwater eutrophication. Comparing the two application scenarios by an assessment of the impacts, the preferable system is drive system 1 in application scenario 1 and drive system 2 for scenario 2.

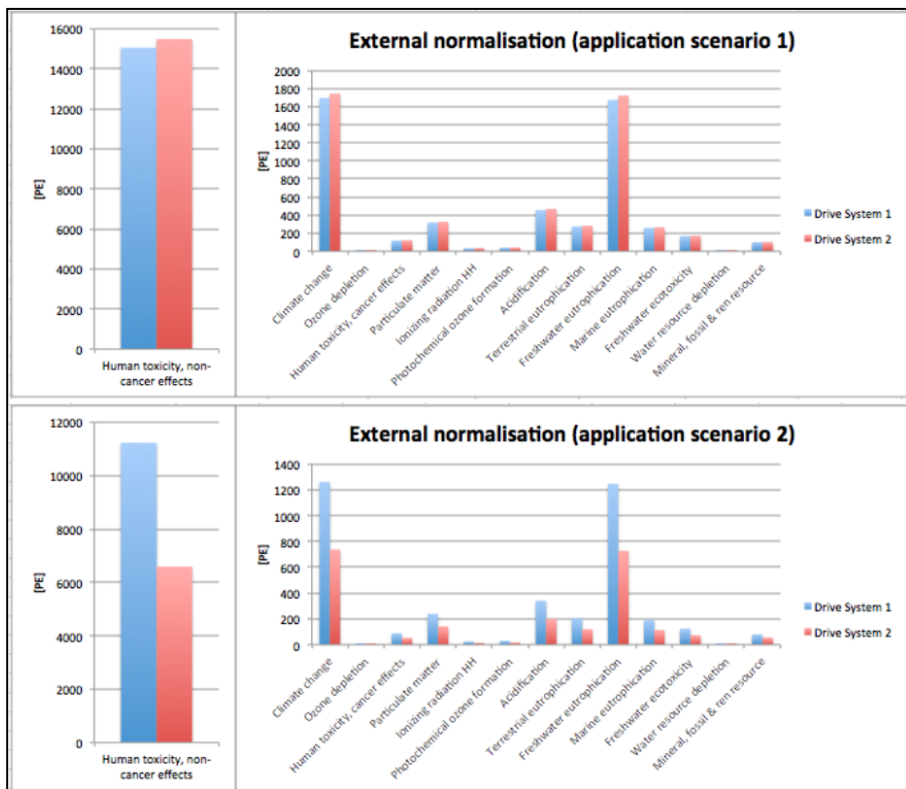

Figure 68: Normalized LCIA scores the two drive system in the two usage scenarios. Human Toxicity is shown separately due to the scale [JP-III].

The LCA evaluation corresponds to the use stage performance, as shown in **Table 26**, which shows that the other life cycle stage can basically be neglected because they are not significant.

### 8.3.2.2 LIFE CYCLE COSTING

**Table 27** summarizes the results of the LCC and it shows that in total the operational cost dominate the costing in both application scenarios. It also shows that in scenario 1, the Drive System 1 performs economically better, about 3 % over the 15 years of assumed service life. In scenario 2 the Drive System 2 performs economically better, by about 45 % over the 15 years of service life.

Table 27: Summary of the LCC of the two drive systems in the two application scenarios.

		<i>Drive System 1: Fixed Speed Drive with IE3-Motor (FSD-IE3)</i>	<i>Drive-System 2: Variable Speed Drive with IE3-Motor (VSD-IE3)</i>
<i>Investment Cost</i>	Motor	25,400 €	28,193 €
	Soft Starter	1,450 €	
	Frequency Converter		10,120 €
	Total	26,850.00 €	38,313 €
<i>Operational Cost - Scenario 1 (FS)</i>	Energy cost per year	111,115 €	113,519 €
	Energy Cost per 15 years	1,666,726 €	1,702,798 €
<i>Operational Cost - Scenario 2 (VS)</i>	Energy Cost [€/a]	80,743 €	43,015 €
	Energy Cost per 15 years	1,211,153 €	645,229 €

### 8.3.2.3 ECO-CARE-MATRIX

As explained in the methods section the ECM visualises the results from a LCA and a LCC in an eco-efficiency matrix to support decision-making. For both applied use stage scenarios,



the results will be displayed setting the Drive System 1 (FSD-IE3 = Fixed Speed Drive with IE3-Motor; throttle control) as reference for the comparison with Drive System 2 (VSD-IE3 = Variable Speed Drive with IE3-Motor, Frequency Converter control).

*Application Scenario 1: Constant Flow – Fixed Speed*

**Figure 69** now displays the ECM for the constant flow application with fixed speed, as the results explain in the previous section already indicated, the difference in percentages are marginal (2 – 3 %). In absolute values DS2 is about 50,000 € more expensive (39,000 in use stage over the 15 years, 11,000 in investment) and emits about 0.19 Mt more in CO<sub>2</sub>-eqv. (German electricity mix).

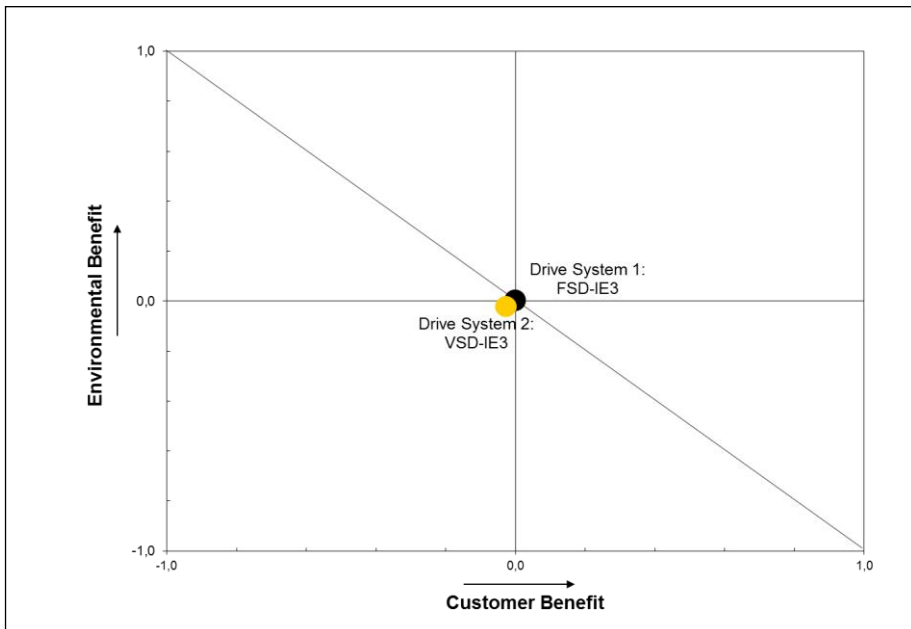

Figure 69: Eco-Care-Matrix of the two drive systems in the constant flow (continuous operation, fixed speed) application scenario [JP-III].

“Eco-design 2.0” (application-oriented) studies in context to reference applications

*Application Scenario 2: Variable Flow – Variable Speed*

Here another drive system was added in this context. It is also a fixed speed drive system as DS1 but utilizing an IE4-motor instead of the IE3-motor as in the base case, and therefore will be referred to as DS1.1. [R-II] already looked into comparing the environmental performance of motors with different efficiency classes, whereas in this case the goal was to quantify the potential performance increase on system level compared to the component level. Background data for the ECM is summarised in **Table 28**.

Table 28: Configuration and background data for Drive System 1.1; A fixed speed drive with IE4-Motor (FSD-IE4) instead of the IE3-motor as in the base case.

		<i>Environmental data:</i>	<i>Economic data:</i>
<i>Materials &amp; Manufacturing stage; Investment cost</i>	Motor	3773 kg CO <sub>2</sub> -eqv.	28,600 €
	Softstarter	180 kg CO <sub>2</sub> -eqv.	1,450 €
	Total	3953 kg CO <sub>2</sub> -eqv.	30,050 €
<i>Scenario 2: Variable Speed Application</i>			
<i>Use Stage / operational costs</i>	Energy Consumption [kWh/a]	667,286	
	Per year	421,725 kg CO <sub>2</sub> -eqv.	80,074 €
	in total over 15 years	6,325,871 tons CO <sub>2</sub> -eqv.	1,201,114 €

**Figure 70** now displays the ECM for the variable flow application with fixed speed, as the results explained in the previous section already indicated; a significant improvement in economic and environmental performance can be achieved by the system design (adding the frequency converter).

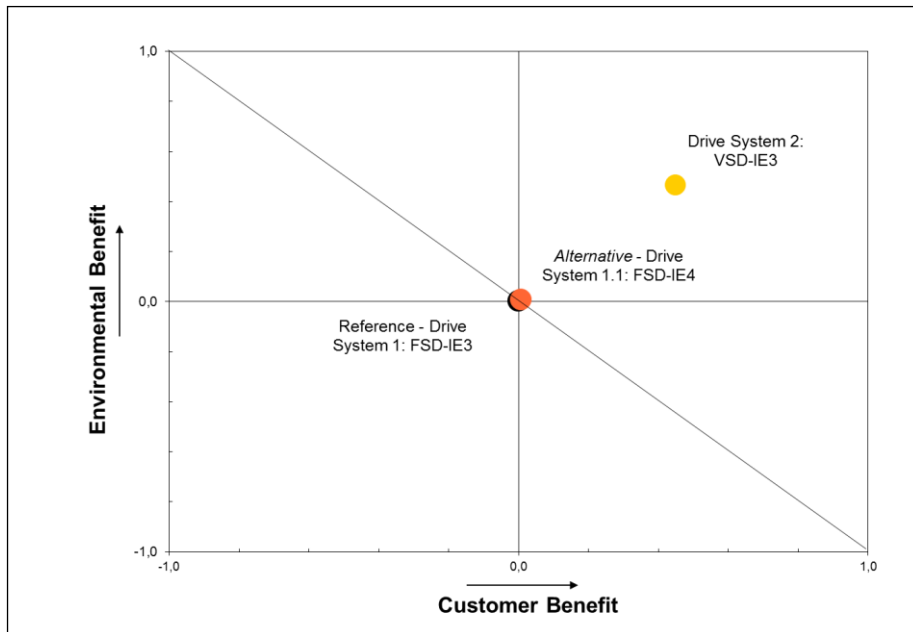

Figure 70: Eco-Care-Matrix of the two drive systems in the variable flow (variable speed) application scenario [JP-III].

In percentages, the increase is about 45 % in both dimensions from DS1 to DS2. This corresponds to savings of about 550,000 € and 3 Mt of CO<sub>2</sub>-eqv. (German electricity mix). The higher investment is easily compensated by the savings in the use stage; break-even of the investment was calculated to 3.6 months in this application scenario in SinaSave. In comparison, the DS1.1 increases performance, environmentally and economically, only about 1 % compared to the reference set-up (DS1).

### 8.3.3 INTERPRETATION & DISCUSSION

In the material stage the copper is responsible for most of the impacts followed by low-alloyed steel and cast iron, which are all components of the motor. The highest impact categories in this context are human toxicity, freshwater eutrophication and particulate matter, shown in **Figure 71**.

“Eco-design 2.0” (application-oriented) studies in context to reference applications

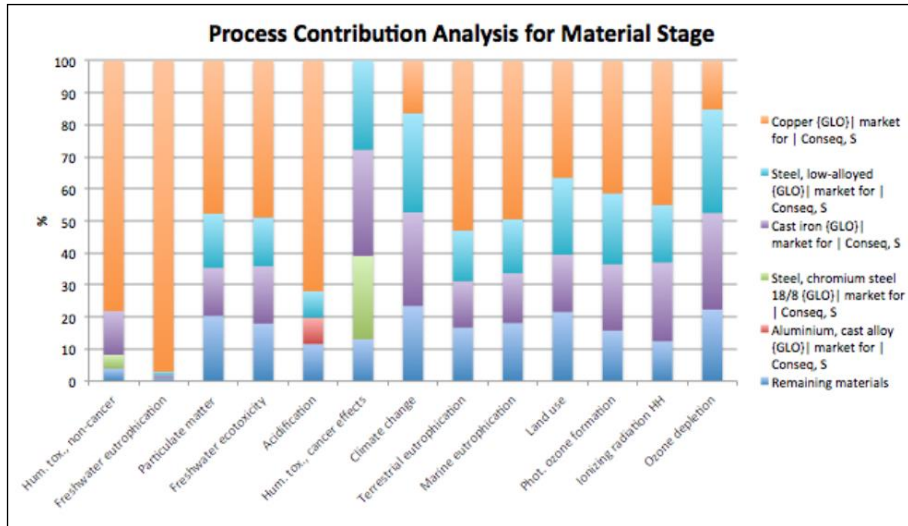

Figure 71: Process contribution analysis for material stage in percent [JP-III].

At the manufacturing stage, the impact category human toxicity has a very high score, followed by mineral, fossil and renewable resource depletion and particulate matter. It can be seen in the process contribution analysis (**Figure 72**), that the casting of steel causes about 80-90 % of the impacts in each category.

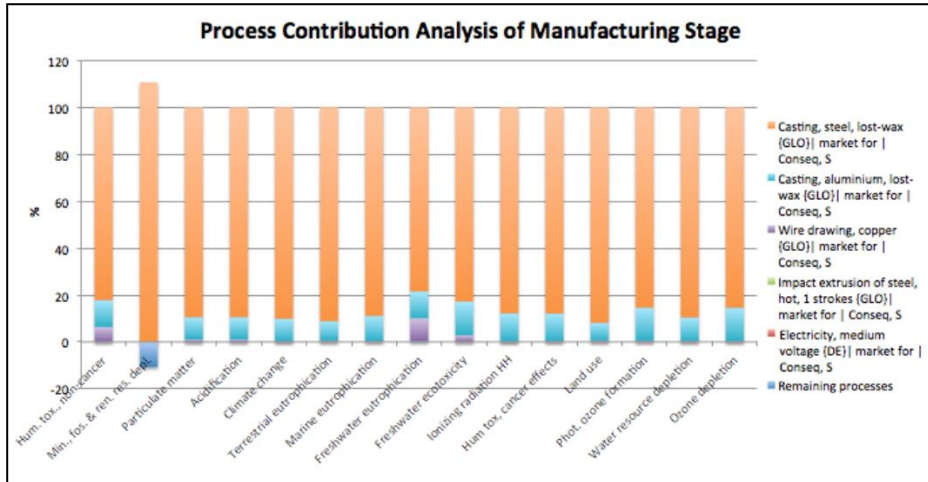

Figure 72: Process contribution analysis of manufacturing stage [JP-III].

In the use stage, the energy consumption (low voltage electricity, German grid mix) which runs the drive system and the connected pump is responsible for the vast majority of all impacts during the whole life cycle. Except mineral, fossil & renewable resource depletion, the use stage accounts for 97.1-99.9 % of the impact in all categories.

At the end-of-life stage, the process of copper scrap is the main driver (93 %) behind the highest impact score of mineral, fossil and renewable resource depletion. The remaining impact categories have impact scores that are either negative or close to zero. The electricity consumption related to the disassembly of the products is the highest contributor in the majority of the remaining categories.

The energy consumption during the use stage is the major contributor to all impact categories, while the process of steel casting is the main contributor to the impact scores in all categories at the manufacturing stage. The emission of carbon dioxide is the dominating elementary flow in climate change. Copper can be seen as the dominating factor regarding materials originated from the motor. The main contributing impact categories are climate change followed by freshwater eutrophication.

Because of the high use stage dominance, a scenario check has been carried out to investigate the parameters that might have a high influence on this stage. In this context the electricity grid mix as well as the efficiency of the motor has been examined. It is assumed that a decrease of motor efficiency leads to an increase in the overall impact of the use stage. In comparison

with the German electricity grid mix the Danish grid mix has better results in the three highest impact scores human toxicity (↓40 %), climate change (↓25 %) and freshwater eutrophication (↓70 %).

LCC was approached in a very simplified manner, compared to [R-I; R-II] only taking into account today's components prices and the cost for energy consumed, not aspects as installation and maintenance costs or the development of the price for electricity and depreciation. The results of the LCC correlate to the LCA, in terms of PE and the impacts driven by electricity consumption.

It can be concluded that Drive System 2 has the best overall environmental performance and is the preferred choice, when taking both application scenarios into account. In the application specific view Drive System 1 performs marginally better in application scenario 1, and Drive System 2 performs significantly better in application scenario 2. Human toxicity (non-cancer effects), climate change and freshwater eutrophication are the categories causing the highest impact scores. For most impact categories, about 97.1-99.9 % of the impact comes from the electricity consumption in the use stage. The extraction of copper during the material stage is the most contributing process, while the steel casting process is dominating the manufacturing stage. Therefore is the reduction of the power demand, because of higher energy efficiency, of the drive system a major lever for the reduction of environmental impacts.

In the end, the results showed the significance of a system design optimized to the application needs concerning both the environmental as well as the economic performance. The

conducted case study in this set-up showed, that EPA as a facilitator (or interface) between electro-technical performance evaluation of the use stage of drive systems corresponding to the application and the eco-efficiency evaluation based on LCA and LCC works quite well. The EPA basically links or translated the application requirements to drive systems parameters and can therefore be used to describe the underlying functional unit of both assessment methodologies (LCA, LCC). The ECM in the end displays the performance very boldly in this regard and will support decision making even for non-experts.

The outcomes of applying the EPA were shown in this case study and proved that the approach can reveal decisive insights, not obtained when looking at system parts alone. A concrete example being that a drive system with a motor from a lower efficiency class (IE3) turned out to be some 45 % better performing in the environmental dimension (and in the economic dimension, too) than a comparable drive system using a higher efficiency class (IE4). This was shown in Figure 70 in context of the application scenarios analysed by means of the Eco-Care-Matrix (ECM). Apart from the concrete results, running scenarios with the ECM also showed that the ECM itself can be a powerful means to communicate results obtained through applying the EPA. Such an integration of the EPA in the ECM may be relevant in ecodesign projects to visually express quantitative comparisons of alternatives.



A potentially huge influence of the EPA is seen in relation to its application within scope definition of LCAs. Practitioners or entire organisations may voluntarily choose to use the EPA as inspiration or internal standard procedure. However, if the LCA ISO standards 14040 & 14044 would be amended by a clear recommendation or even a requirement to adopt the EPA during the scoping phase of the LCA, a large shift in results and subsequent decisions can be expected (as seen in the scenarios presented here), both in industrial decision-making and in public policy-making. An obligatory adoption would require preceding standardisation efforts, e.g. the development of guidance for other industries and applications than electric drive systems, wherever meaningful. The EPA is especially relevant when designing systems and selecting components, e.g. motors electric in drive systems, and systems where potential power losses are key. Thus, with regard to existing systems and installations, a revisiting (and potential recalculation) of related LCAs is not seen necessary, even if EPA integration would become obligatory. However, when considering to exchange components, the EPA would show its influence on the decision (which may well be to keep the component).

As stated, use of the EPA on even wider and or larger systems can be done is judged meaningful. An exploration of such meaningful applications could start with larger electric systems, e.g. entire washing machines, to entire heating/cooling systems, and then to systems indirectly affecting energy consumption such as windows (following the EU term “energy-related products”, see section 3.3). It could also be applied to design decision-making only on well-defined levels of very large systems, e.g. production equipment (as indicated in [Rödger et

“Eco-design 2.0” (application-oriented) studies in context to reference applications

al., 2016]). Regarding entire products, it may though show more meaningful to use the instrument of Ecolabelling, with generic criteria, rather than requiring individual specific assessments.

### 8.3.4 CONCLUSIONS

With the new standard series EN50598 for drive systems, issued in 2015, the first comprehensive and holistic ecodesign standard for drive systems has been developed in the context of standardisation mandates issued by the European Commission relating to the ErP directive (see chapter 8.2).

This corresponding eco-efficiency case study, using the ECM with underlying LCA and LCC, applying the EN50598 standards series in a pump application context, showed the benefits of the extended product approach in terms of environmental impact scores and the economic performance. The EPA can be seen as the interface of the application aspects to the parameters of supporting (drive) system, facilitating the definition of a proper, specific functional unit for the underlying methods of the ECM.

The case study also showed that in this set-up the levers on system level regarding application specific design are higher than what is achievable on component level.

The basic concept of this approach, based on the EPA and the underlying SAM, may be a concept also applicable in other (complex) product systems dealing with energy and/or resource efficiency in application context. Key success factor is an extensive collaboration of affected product systems and their applications, to define the relevant operating points and corresponding usage scenarios. Here the processes and work

platform of standardisation provides a proper set-up for facilitating these technical rules.

## 9 SUMMARY & DISCUSSION

This section will provide a summary of the results elaborated by the evaluation of the research background and the corresponding case studies. These results will then be discussed in context to the Ecodesign 2.0 approach, since the individual results of the case studies already were discussed in detail in the chapters 7 and 8, based on [JP-I; JP-II; JP-III; C-II].

The evaluation of the research background, ecodesign of automation and drive technologies for larger scale industrial manufacturing systems in discreet and process industries, provided the foundation of defining reference applications and corresponding case studies. The currently, widely implemented state-of-the-art of ecodesign was seen as either being dominated by primarily qualitative approaches applied mostly on product (component) level. The current period (of ecodesign) was classified as “maturation of ecodesign” for general research as well as industry implementation approaches, where there are not too many disruptive changes in play, but rather a lot of research is dealing with specific details of the basic concept of an holistic environmentally conscious design (dealing with all business processes), as for instance the underlying methods for quantification, the process maturity or the development of product service systems.

Scientific publications, as well as most current standardisation activities prove this point [IEC 2014] of ecodesign process steadily extending its reach into all other business processes, often already taking a system perspective, as evaluated in section 2.5 and chapter 3. On the other hand, Driven by legislation and “soft indication” [2009/125/EC; EC 2013a] certain aspects of

ecodesign still put more focus on single products, which are often utilized in larger systems, potentially leading to a suboptimal system design [CEMEP 2015; CAPIEL 2016]. No references were found for explicitly promoting an application view in a broader sense in an eco-efficiency approach, and few for promoting at least a dedicated usage scenario as for instance in the [EN 15804:2012] approach. A gap has been identified in research concerning projects on how to tackle the issue of a proper interface description between the application(s) and supporting systems including its components, especially from policy side.

This point has been fulfilled within the scope of this PhD project, for the identified reference applications, which can be accessed in drive technologies (e.g. for IPSS as the IDS) via the defined ‘application vs. operation class matrix’ (Figure 25). The relevance of an application view has been displayed prominently, besides the indications in case studies on drives for machine tools [R-II, R-III], especially the case study on the drive system for a centrifugal pump application as laid out in the corresponding section 8.3 of this thesis [JP-III].

In the end, a smart approach concerning the interfaces between the application, the system and its components can be seen as crucial. Only the [EN50598:2015] can be named as a “lighthouse” in this context, utilized in the above-mentioned case study (also disseminated via [C-II]) for definition of an application-specific functional unit, based on international standards and data provided in manufacturers’ product datasheets and therefore easily transferrable to other applications. Here, on the other hand, one could claim the distinctiveness or clarity of the centrifugal pump case and the

210

supportive settings [JP-III], and the therefore foreseeable result. As well as, that is was basically the only real ecodesign 2.0 case. At this point it should then also be mentioned that the other key cases on the machine tools, the vertical mills and individual sections machines [R-II; R-III; R-IV; JP-I], already – to some extent – took an application view, supporting the approach, whereas they also gave an impression about the variety of potential parameters that can be relevant. Still, in most cases the potential usage scenarios of products will be somehow limited by an economic sense (CAPEX vs. OPEX, short vs. long life cycles), a fact that is indeed providing the jump-off platform for the ECD2.0 idea in general.

Further summarizing the results for the evaluation of the research background, the settings of the markets influencing this “economic sense” have been identified as key factor concerning a successful, effective implementation of ecodesign and therefore the Ecodesign 2.0 approach. This was not surprisingly, but frankly approved along the research with dialogs, in the course of the case studies, with product managers, engineers and sales functions. This then leads to the relevance of “systems thinking” in general (ecological, economical, as well as manufacturing or drive systems) and multi- to interdisciplinary approaches for developing solutions for current sustainability challenges [COSI 2015].

Another point elaborated was the relevance of the efficient modelling approaches for quantitatively assessing the relevant environmental (or sustainability) parameters, since extending the scope further will definitely increase necessary efforts. In the best case, this is supported by a better global, top-down framework (e.g. policies) concerning the relevance of the environmental impacts, which would enable the development and utilisation of sound and robust simplification approaches. Moreover, in case of a proper integration of these topics into framework policies and associated, harmonized standards, the relevant data should be available – at an appropriate level of detail – for instance in product documentation. This then also, when LCA is applied, requires further target-oriented research on characterization models, normalisation factors and weighting to increase the robustness of the obtained results. The point is very relevant concerning the potential conflict of interests between energy and material efficiency, let alone toxicity. Hence this could lead to a “show stopper” concerning a success of ECD2.0, since the necessary global agreement underlying this prerequisite can be seen as too idealistic to be achieved in reality. But, if in essence crucial, these points of increasing robustness of characterisation and the balance between accuracy and necessary efforts, apply to all ecodesign approaches regarding their effectiveness concerning global sustainability challenges, as well as for manufacturers concerning their business success.

Therefore, it can be stated that the conducted case studies showed, that using an eco-efficiency methodology, as outlined in chapter 5, underlying the ‘Ecodesign 2.0’ approach makes sense. In all evaluated cases, the levers on systems level targeting the specific requirements of the application have higher influence on

the environmental performance, than individual measures on component level. Applying a “classic”, i.e. single-product focused, optimisation approach can lead to significant, unintended sub-optimisations or even worsen the performance of the mentioned systems, whereas small changes on the system level, e.g. for different or new components, can have huge impacts on the sustainability profile of the entire application. Although decisions regarding the top level of the manufacturing system, i.e. the level regarding the entire facility, are potentially most influential for the sustainability profile, the suggested system- and application-oriented scoping and modelling is also relevant and applicable at the lower levels of the manufacturing system, e.g. on production line level or on production cell level [Dijkman et al., 2015].

Further, comparisons of absolute data on environmental impacts on product level are not very robust when considering uncertainties, whereas comparative assessments with the identical goal & scope definition and modelling approach (tools, secondary data) enable the practitioner to manage the robustness of the results and therefore improve usability in decision-making context. Still, the scoping (incl. system delimitations and functional unit definition) in the assessment procedure of complex manufacturing systems requires much more careful consideration than in LCAs (as well as in LCC) for “classic” products which leads back to the necessity of a proper foundation through, ideally, global policies, standards and the like.

The consideration of a customer benefit dimension, e.g. cost savings, supports a successful market penetration of the “eco-



designed” products and therefore is a necessary parameter to consider from the manufacturer perspective as well as for other stakeholders. Most recent developments in Germany concerning the national climate protection approach, also stress this issue [BDI 2017].

Here it can be discussed that in drives, as the specific scope of this research, the key parameter for both dimensions (environmental, when energy-related impacts considered, and customer benefit) in the ECM is the same. This is a very favourable setting that may not be the case for all potential applications.

All in all, no substantial drawbacks are seen for the further promotion of the proposed Ecodesign 2.0 approach, let alone any dedicated obstacles.

## 10 CONCLUSIONS & PERSPECTIVES

This section now provides the conclusions drawn from the evaluation of the research background and the corresponding case studies, in context to an outlook of potential aspects of its application. These conclusions will then be discussed in context to the Ecodesign 2.0 approach, since the individual conclusions of the case studies already were summarized in the respective chapters 7 and 8, based on [JP-I; JP-II; JP-III; C-II].

### 10.1 ECO-DESIGN 2.0 IN A NUTSHELL: THE REVIEW OF ITS CORE REQUIREMENTS IN CONTEXT TO ITS APPLICATION

The basic concept of the Ecodesign 2.0 approach, utilizing the Eco-Care-Matrix as an eco-efficiency tool, with the underlying methods Life Cycle Assessment and Life Cycle Costing to quantitatively determine environmental and customer benefit has been proven as beneficial and useful by this project. The analysis of the complete modernized manufacturing system for container glass bottle production and the case study on centrifugal pumps showed that the largest contribution to the environmental impact and to the economic costs is related to the energy requirements during the use stage. As a consequence, the highest opportunities for reducing potential environmental impact and costs, can be realized by upgrading the system by e.g. including motion control, servo drives and/or converters.

The case study of the comparative assessment of the motors with different efficiency classes, also showed the relevance of the load-time profile, indicated by the comparison between the two usage scenarios, and the motor's service life. Hence, it is crucial

to evaluate the environmental performance of a motor or rather a drive system optimized in context to the specific characteristics of the application scenario. Another point in that context is generalization of the results of the study to other motor sizes (nominal power). Efficiency gains of motors with smaller nominal power, will be lower in absolute numbers, as well as the assumed service life be shorter (10-15 years), this could then lead to different results concerning the trade-offs or rather the environmental break-even of these impacts.

The LCA case study on electric motors with different efficiency classes and the case study on the vertical mills, led to the conclusion that the management of aspects not related to climate change (or driven by energy consumption) will require special attention, especially considering the uncertainties and discussions underlying the available impact assessment methods for toxicity and resource depletion. Thinking this through it can be concluded that decision-making supported by LCA is still difficult because of the uncertainties through immature impact assessment and characterization models, generic secondary data and the lack of proper external normalisation factors, reflecting the carrying capacity of the ecosystems and political consensus on the weighting of the individual impact categories. Therefore, decisions in ecodesign context should be taken carefully and the robustness of the characterization models for toxicity and resource depletion indicator should be increased to avoid burden shifting or a more general dilemma.

Still, LCA and LCC are both rather mature concepts and capable to reflect for instance scientific developments [Bjørn & Hauschild, 2015; Ryberg et al., 2016], as well as the development of market mechanism [EC 2015b]. Even more important is their flexibility to model scenarios and therefore seem to be appropriate methods to support the ECD2.0 approach. An overview of the current implementation of ECD2.0 in Siemens PD is shown in **Figure 73** and could be, in principle, transferred by contextualisation to other companies and manufacturers.

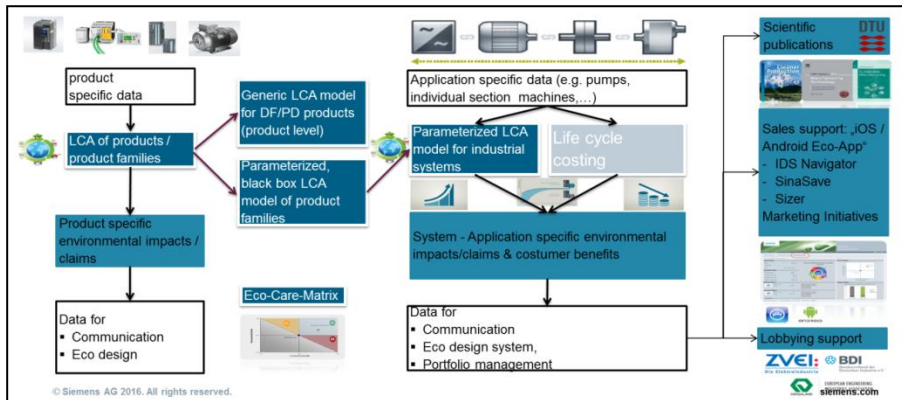

Figure 73: Overview of the Ecodesign 2.0 implementation in Siemens PD. In the current approach, LCA of products are utilised to generate parameterized models that can then be used to model systems in application specific views, providing results for publications, sales and lobbying.

The figure shows, that there are different stages necessary for a full-scale implementation. First a base of quantitative environmental data for the products, which are components to systems, is necessary. In the best-case for product families, based on harmonised rules (e.g. like internal product category rules), already derived by a systems perspective to properly balance accuracy and necessary efforts, and an efficient modelling approach, like a preconfigured model. These assessments can then be used to build parameterized LCA-models for the product families that can then be utilised in a (automation/drive) system model. This enables the practitioner to build and assess the systems environmental performance in application context, by setting the relevant parameters of the underlying components. Efforts are significantly reduced compared to a modelling of each system from scratch. Contemplating the results of the LCA with the results of a corresponding LCC, the ECM can be drawn and interpreted (i.e. is a design to cost necessary? Are further

optimisations for the environmental performance necessary), and further on, the results can be used in communication (e.g. marketing, sales) and product portfolio management.

Concerning the future work, the applied eco-efficiency analysis tool, the ECM, is meant to be further developed for optimizing the IPSS of Siemens, the Integrated Drive System, in regard to the included product and service portfolio. The further development of the method should aim at combining technical, economic and environmental aspects in regard to the targeted application and thus to further optimize the offering, for instance by identifying and evaluating additional portfolio elements or further integration needs. Based on the needs of an application, a solution can be derived from the existing system components. By applying LCC and LCA (as underlying methods of ECM) drivers for cost and environmental impacts can be identified (e.g. in investment or operating costs, energy consumption related emissions or resource consumption). Based on this analysis e.g. an additional portfolio element could then be identified and the improvement evaluated again by LCC and LCA using approximations and/or reference data. The ECM could then be used to display the options in a comparative view with the initial solution as reference point. This would even be more interesting if more than two options should be compared. Here research could address the combination of the ECM with multi-attribute decision analysis. In any case, this requires switching from a retrospective, as in these case studies, to a foresight application of the eco-efficiency tool. **Figure 74** visualises the concept, currently under development at Siemens PD [Auer et al., 2017].

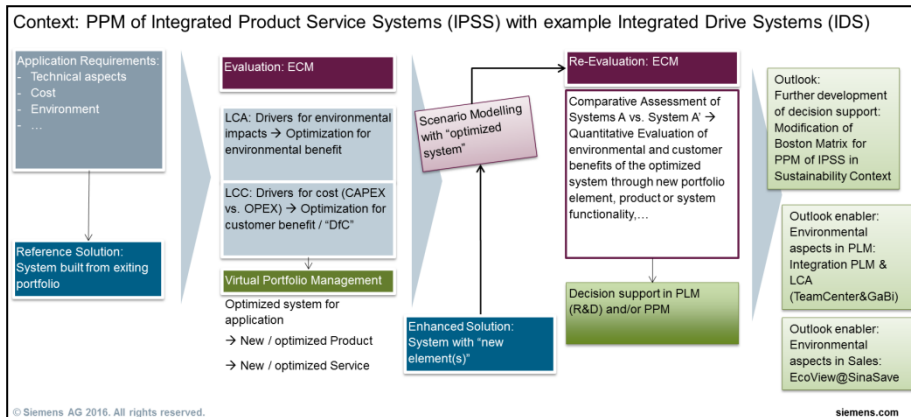

Figure 74: Graphical visualisation of the application of ECD2.0 approach in product portfolio management [Auer 2016b].

However, especially for the LCA – or more generally, for the evaluation of the environmental aspects – simplifications or rather smart approaches are necessary, balancing efficiency with accuracy, to be able to build a consistent and flexible model of the IPSS. This will be set forth in the next section.

## 10.2 DIGITALIZATION AND ECO-DESIGN: INTEGRATION OF LCI IN PLM TOOLS

Conducting LCA studies of large scale manufacturing systems is a rather labour-intensive and lavish task. For instance, in [JP-I] more than 600 components had to be taken into account, to allocate the environmental impacts (as well as the benefits) to certain functionalities of the system. To quantify it corresponding to the assessment: Out of the 632 components and devices used to modernize the system, approximately 300 would have to be assessed in detail (full scale LCA); Using 52 h as an average mean time for conducting the LCA based on [C-I] this leads to 15,600 working hours for LCA experts to carry out the various studies; using 60 € as hourly wages, this leads to costs of

220

936,000 € for carrying out the LCA for the manufacturing system. Surely this is “overkill” for the methodology in this context, whereas in the end, in terms of environmental aspects, manufacturing, as well as distribution and end-of-life stages can almost be neglected in an industrial context with service lives from 10 to 20 (or even 30) years and the corresponding high quality requirements, realized through high quality materials, service and reparability. Similar conclusions were drawn in other case studies in different application contexts, e.g. pumps [Smith 2011; CAPIEL 2015; CEMEP 2015] and compressors [Siemens 2014a], and today even reflected in a corresponding standard for drive systems [EN50598-1:2015]. So at this point the importance of the message – “carefully consider the application setup and scenario” – has to be stressed (again) to avoid counterproductive sub-optimizations at the component level in the system context or micro optimization.

Therefore, it can be concluded further that when using LCA as a method for ecodesign at the system level or in the context of the product environmental footprint [EC 2013b], valid simplifications are necessary for the assessment of these life cycle stages.

Applying LCA to support ecodesign, the key recommendation is to (i) adapt the methodology to the system perspective and to (ii) be able to map the applications in this context. For instance, the enhancement of system engineering tools with relevant environmental indicators would be an option to promote ecodesign on a larger scale than just providing data for up to 30 different environmental impact categories as is the case in some



environmental product declarations in building context [EN 15804:2012].

Concerning the evaluation of the environmental performance of the solution, also further work has to be done on defining normalisation and weighting schemes to enable a robust decision support based on different, and maybe contradictory, impact indicators. Additionally, another core activity will be the integration of the ECM tool, or at least certain aspects of it, into product life cycle management (PLM) tools, as well as into system engineering tools and marketing concepts in order to consider and show the benefits of the IPSS application specifically.

Two approaches in this context are currently under development by Siemens in collaboration with thinkstep [Auer & Betz, 2017].

The first option makes use of a module of the Siemens PLM software TeamCenter (TC), which enables to store and manage material or parts data (as properties, curves, tables) and link it directly to a Bill of Materials (BoM). In addition, a roll up of data along the BoM structure and the generation of reports is then supported out of the box: By assigning a material to a part in a CAD system or in the PLM system, all material information, including environmental life cycle impacts, and can be aggregated from part to product level. If this is the case, automatically, whenever the material or part is assigned to the product structure, the environmental impact information is also available, and can be rolled up by the solution. Roll up means here, that the specific impact value of one data object (e.g. material) is multiplied by the mass (or number of parts in case of a part) and added up with the corresponding values of all other

objects along the BoM structure and available for reporting. The Role of GaBi software is to calculate the environmental impacts of the needed raw materials and parts to fill the materials database held by the PLM system. Limitation of this approach is the considerations of manufacturing processes or auxiliary materials which are not maintained in the BoM. Hence results may be misleading in case of a high relevance of these aspects. On the other hand this approach means ecodesign “on-the-fly” directly by the designers and developers, as well as other functions involved in product development.

Another approach is combining a special XML export of the product’s bill of material (BoM) from the Siemens TeamCenter product life cycle management tool with the BOM-Import functionality of thinkstep’s GABI DfX. Here the DfX module of GaBi software can directly import the extended bill of materials information, map it to the corresponding data objects in GaBi and set up automatically a virtual product model in the LCA software. This approach offers all flexibility for LCA modelling, but on the other hand is again detached from the product design process and would also require more LCA expertise.

These two approaches are – more or less – meant for initially conducting LCA on product (as components to system) level. To support the modelling of systems in application view, the development of parameterized, so-called “Black-Box-Models”, were evaluated as beneficial by [R-I; C-I; R-V; R-VI]. Referring to section 10.1, **Figure 73**, these can facilitate the environmental assessment of the corresponding system. Backbone of these models are systematic assessments of key components of a product family, resulting in the evaluation of correlations in

terms of mathematical functions (i.e. linear, stages, on/off) of the products (material) composition to specific parameters [R-V; R-VI].

### 10.3 ECO-CARE-MATRIX IN SALES CONTEXT: ECO-VIEW

Another outlook of the implementation of an aspect of the Ecodesign 2.0 approach in business is the application in Sales & Marketing. In 2015 a preparatory study was conducted in Siemens PD to check the development of an additional view in the SinaSave tool, the EcoView. As explained in the case studies, as it was used as basis for the calculation of the power demand of drive systems, SinaSave is a web tool provided by Siemens to compare the electrical (energy demand) and economic performance of drive systems and motors in applications context (load-time profile, pumps, ventilation). **Figure 75** shows the screen of SinaSave where certain parameters of a pump application and two different drive systems can be configured.

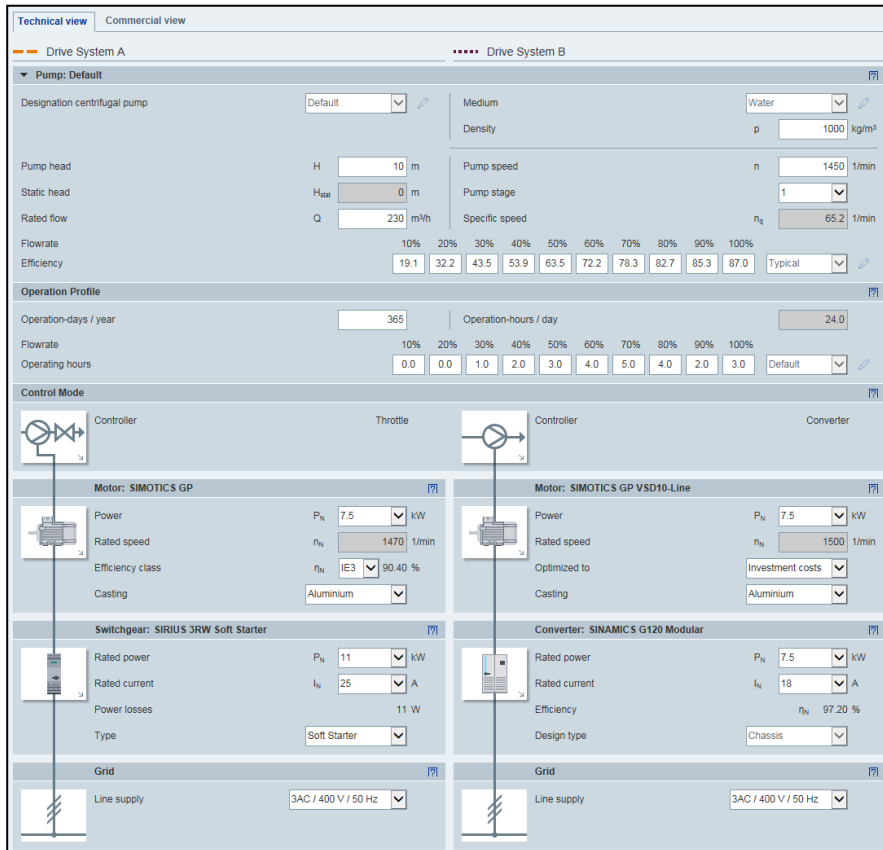

Figure 75: Screenshot of SinaSave for configuring the parameters of a pump application [Auer 2016c].

**Figure 76** then shows the results of the comparison of the electrical performance by the means of kWh saved, **Figure 77** the results of the economic performance by the means of cost savings.

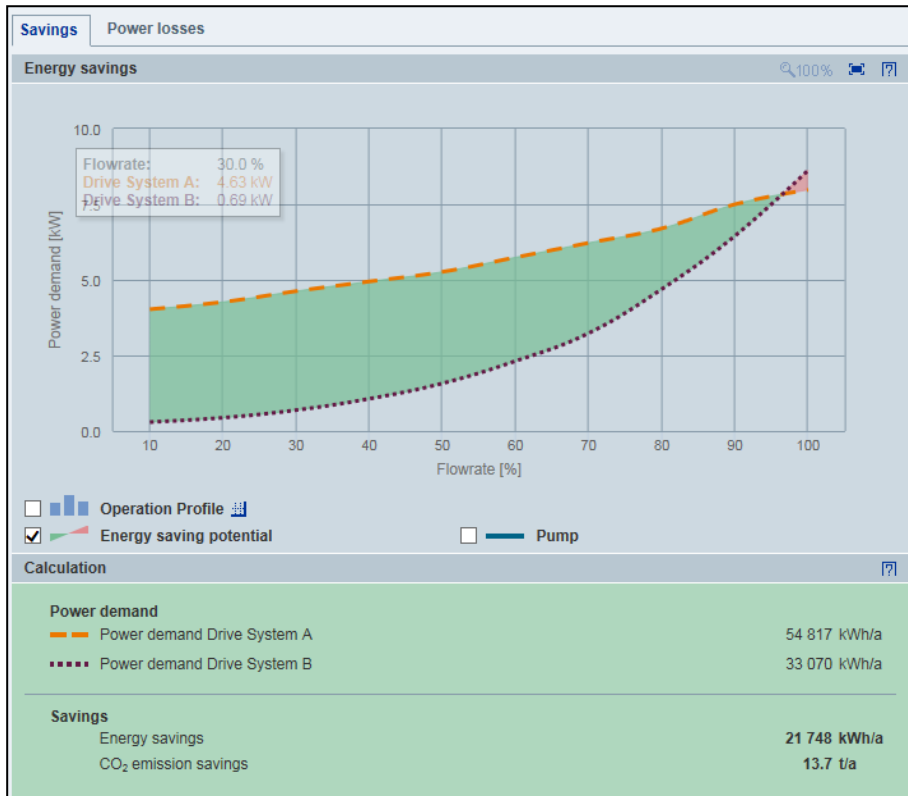

Figure 76: SinaSave calculation of electrical performance of the two drive systems, visualization of the comparative performance assessment in terms of potential energy savings [Auer 2016c].

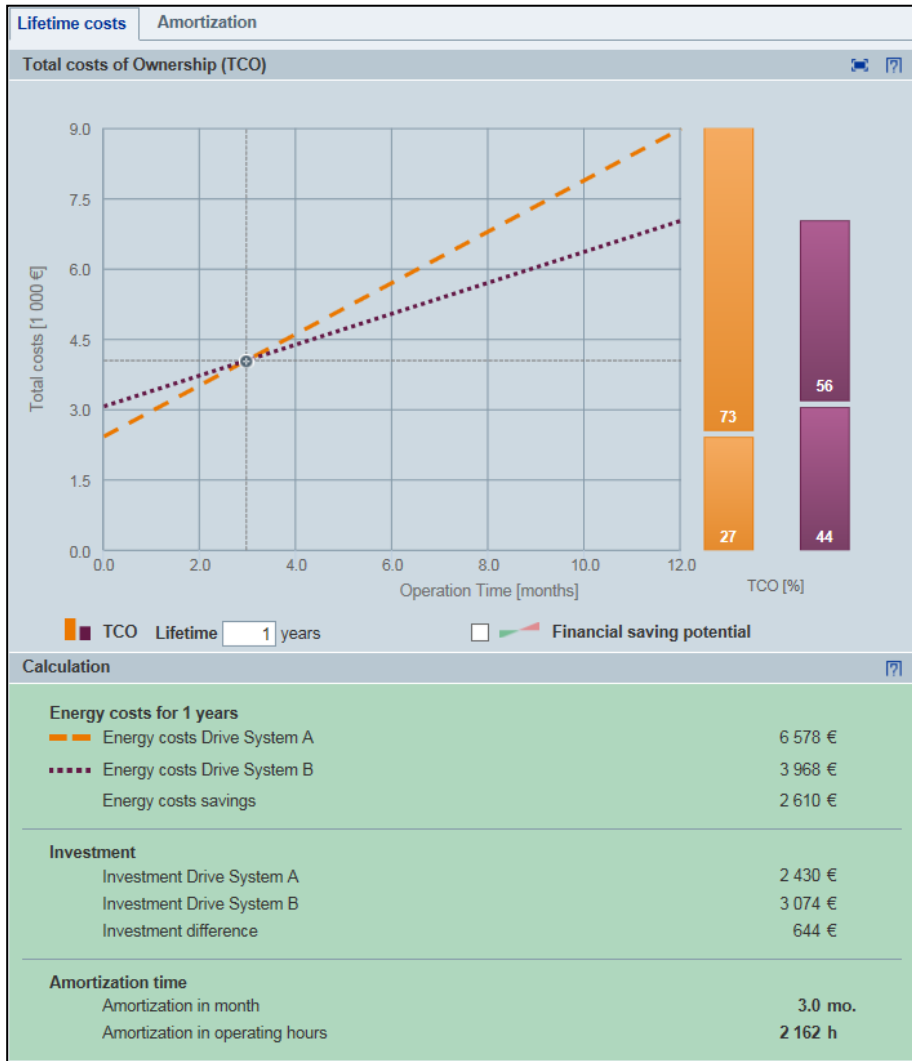

Figure 77: Display of comparison of economic performance in terms of TCO, monetary amortisation time and energy cost savings [Auer 2016c].

The idea of the EcoView is then shown in **Figure 78**, where an additional tab (ecological view, beside the technical and the commercial view) would display environmental key performance indicators by the means of environmental impacts, derived by

LCA, in the ECM, as well as in columns. The user can then easily see the results of a comparative assessment of different indicators, as for instance the global warming potential, particulate matter or resource depletion, depending on their interest of needs. This could further support a holistic ecodesign on system level.

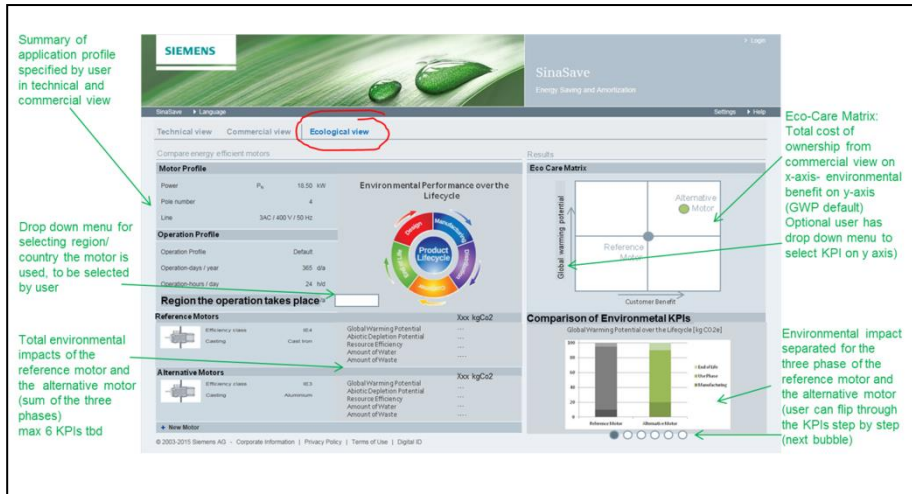

Figure 78: The concept of the EcoView enhancement of SinaSave, by the integration of a third tab (Ecological View) to display the comparison of the environmental performance by environmental impact indicators in the Eco-Care-Matrix [Auer 2016c].

# REFERENCES

- [2002/95/EC] DIRECTIVE 2002/95/EC OF THE EUROPEAN PARLIAMENT AND OF THE COUNCIL of 27 January 2003 on the restriction of the use of certain hazardous substances in electrical and electronic equipment.
- [2002/96/EC] Directive 2002/96/EC of the European Parliament and of the Council of 27 January 2003 on waste electrical and electronic equipment (WEEE).
- [2005/32/EC] Directive 2005/32/EC of the European Parliament and of the Council of 6 July 2005 establishing a framework for the setting of ecodesign requirements for energy-using products and amending Council Directive 92/42/EEC and Directives 96/57/EC and 2000/55/EC of the European Parliament and of the Council.
- [2009/125/EC] Directive 2009/125/EC OF THE EUROPEAN PARLIAMENT AND OF THE COUNCIL of 21 October 2009 for establishing a framework for the setting of ecodesign requirements for energy-related products (recast). <http://eur-lex.europa.eu/legal-content/EN/ALL/?uri=CELEX%3A32009L0125>.
- [2012/27/EU] Directive 2012/27/EU of the European Parliament and of the Council of 25 October 2012 on energy efficiency, amending Directives 2009/125/EC and 2010/30/EU and repealing Directives 2004/8/EC and 2006/32/EC Text with EEA relevance; <http://eur-lex.europa.eu/legal-content/EN/TXT/?qid=1399375464230&uri=CELEX%3A32012L0027>
- [Agora 2016] Agora Energiewende: Energy Transition in the Power Sector in Europe: State of Affairs in 2015. Review of the Developments and Outlook for 2016, 097/02-A-2016/EN. (2016)
- [Alatalo et al., 2011] Alatalo, Tidblad Lundmark, Arfa Grunditz: Electric Machine Design for Traction Applications Considering Recycling Aspects -Review and New Solution, Proceedings of the Annual Conference of the Ieee Industrial Electronics Society — 2011, pp. 1836-1841
- [Allione et al., 2011] Allione C., Tamborrini P., Elia M.: Eco-efficiency into the lighting design: From an environmental quantitative analysis of the available light bulbs to qualitative guidelines for designing innovative and sustainable lighting system. Design Principles and Practices. 2011;5(6):509-525.



- [Almeida et al., 2008] Almeida, Ferreira, Fong, Fonseca: EUP Lot 11 Motors Final Report February 2008, ISR-University of Coimbra. (2008)
- [Almeida et al., 2014] De Almeida A., Falkner H., Fong J.: EuP Lot 30: Electric Motors – Task 4: Technical analysis existing products, final, ENER/C3/413-2010. (2014)
- [ASME 2015] American Society of Mechanical Engineers (ASME): Owen’s AR Bottle Machine 1903. ASME Landmarks program #86. <https://www.asme.org/getmedia/a9e54878-05b1-4a91-a027-fe3b7e08699e/86-Owens-AR-Bottle-Machine.aspx>. Accessed 14.12.2015
- [Auer & Betz, 2017] Auer & Betz: The Integration of Life Cycle Assessment and Product Life Cycle Management – the next step in sustainable product design? Manuscript draft. (2017)
- [Auer & Weis, 2014] [C-II] Auer & Weis: New standard on ecodesign for power drive systems, motor starters, power electronics & their driven applications: Introducing the Extended Product Approach and product category rules for motor systems, Session 2.14.: Impacts from legislation, lecture 2.14.1. In: CARE Innovation 2014 Conference, Vienna.
- [Auer 2016a] Auer J.: Product Eco Excellence – Ecodesign 2.0. Internal presentation. (2016)
- [Auer 2016c] Auer J.: EcoView@SinaSave. Presentation to the “Siemens AG Innovationsfond”. (2016)
- [Auer 2017] Auer J.: Product Eco Excellence – Ecodesign 2.0, v2. Update 2017. Internal presentation. (2017)
- [Auer et al., 2014] [C-I] Auer, Zintl, Berninger, Bey: Comparison of two different approaches for a simplified life cycle assessment of electronics, Session 3.1.: Sustainability and Environmental Assessment, lecture 3.1.2., CARE Innovation 2014 Conference, Vienna.
- [Auer et al., 2017] Auer J., Wagner E.M., Zwanziger P., Walachowicz F.: Project description for “Support for Circular Economy Package and Product Environmental Footprint in Process Industries & Drives”. Internal project to evaluate options on how to consider environmental aspects as product environmental footprint and circular economy package in portfolio management. (2017)
- [Bare et al., 2000] Bare J. C., Hofstetter P., Pennington D. W., & Udo de Haes H. A.: Midpoints versus Endpoints: The Sacrifices and

- Benefits. State-of-the-Art: LCIA. Life Cycle Impact Assessment Workshop. 2000;319-326.
- [BDI 2017] Bund der Deutschen Industrie (BDI): Klimapfade der Deutschen Industrie. Project commissioned by BDI, facilitated by Boston Consulting Group and PROGNOS, to evaluate options lever, as well as the required framework to reduce climate relevant emissions of the German industries by 80 % / 95 % until 2050 (compared to 1990). (2017)
- [Bertoluci et al., 2013] Bertoluci, G., Eynard, B., Mahut, S. G., Millet, D., Tyl, B., Vallet, F. 2013. Using eco-design tools: An overview of experts`practices. *Design Studies*. 2013;34:345-377.
- [Bertoni et al., 2016] Bertoni A., Bertoni M., Panarotto M., Johansson C., Larsson T.: Value-driven product service systems development: Methods and industrial applications. *CIRP Journal of Manufacturing Science and Technology*. 2016;15(11):42–55.
- [Betrand et al., 2017] Bernard P., Bonnin M., Flourey L., Gremy-Gros C., Henriel-Ricordel C., Rousseaux P., Staigre G., Vincent P.: “Eco-tool-seeker”: A new and unique business guide for choosing ecodesign tools. *Journal of Cleaner Production*. 2017;150: 546-577.
- [Bey and McAloone 2006] Bey, McAloone: From LCA to PSS – Making leaps towards sustainability by applying product/service-system thinking in product development. *Proceedings of LCE 2006, 13th CIRP International Conference on Life Cycle Engineering*. 2006;571–576.
- [Bey et al., 2013] Bey N, Hauschild MZ, McAloone T: Drivers and barriers for implementation of environmental strategies in manufacturing companies. *CIRP Annals - Manufacturing Technology*. 2013;62:43-46.
- [Bhander et al., 2003] Bhander G.S., Hauschild M., McAloone T.: Implementing Life Cycle Assessment in Product Development. *Environmental Progress*. 2003;22(4):255–267.
- [Bjørn & Hauschild, 2015] Bjørn A., & Hauschild M. Z.: Introducing carrying capacity-based normalisation in LCA: framework and development of references at midpoint level. *International Journal of Life Cycle Assessment*. 2015;20(7):1005-1018. DOI: 10.1007/s11367-015-0899-2
- [Bjørn & Hauschild, 2015] Bjørn, A. & Hauschild, M.Z.: Introducing carrying capacity-based normalisation in LCA: framework and

development of references at midpoint level, *Int J Life Cycle Assess.* 2015;20:1005.

- [Borrego et al., 2014] Borrego M., Foster M.J., Froyd J.E.: Systematic Literature Reviews in Engineering Education and Other Developing Interdisciplinary Fields, *Journal of Engineering Education.* 2014;103(1):45–76.
- [Boteler & Malinowski, 2015] Boteler R., & Malinowski J.: The Impact of the Integral Horsepower Amended Rule (1 – 500 HP Motor). Presentation at EASA 2015: U.S. Motor Efficiency Regulation Update. (2015)
- [Bovea & Pérez-Belis, 2012] Bovea M.D., Pérez-Belis V.: A taxonomy of ecodesign tools for integrating environmental requirements into the product design process. *Journal of Cleaner Production.* 2012;20:61-71.
- [Brezet & van Hemel, 1997] Brezet J.C., van Hemel C.G.: Promise, a promising approach to sustainable production and consumption. ISBN 92-807-1631-X. UNEP, Paris, France. (1997)
- [Brondi & Carpanzano, 2011] Brondi, Carpanzano: A Modular Framework for LCA-Based Simulation of Production Systems, *CIRP Journal of Manufacturing Science and Technology.* 2011;4(3):305–312.
- [Brundtland 1987] The Brundtland Commission: "Our Common Future". Report of the world commission on Environment and Development. Oxford University Press, Oxford, UK. (1987)
- [CAPIEL 2016] European Coordinating Committee of Manufactures of electrical Switchgear and Controlgear (CAPIEL): Ecodesign Requirements for Electric Motors – Towards a System-Approach (Brochure). (2016)
- [CEMEP 2015] European Committee of Manufacturers of Electrical Machines and Power Electronics (CEMEP): Energy-Efficiency with Electric Drive Systems. CEMEP (Brochure). Brussels, Belgium. (2015)
- [Chomkhamsri & Pelletier, 2011] Chomkhamsri, Pelletier: Analysis of existing environmental footprint methodologies for products and organizations: Recommendations, rationale and alignment, Institute for Environment and Sustainability. European Commission Joint Research Center. (2011)
- [CLC 2014] CENELEC: European Mandates, <http://www.cenelec.eu/aboutcenelec/whatwestandfor/supportlegislation/europeanmandates.html>. Accessed on 27.06.2016

- [CLC TC2 WG2] CLC TC2 WG2 – environmental aspects of electric motors, EN50XXX, 2nd working group draft, tpb (2015)
- [Clini et al., 2010] Ed. Clini C., Musu I., Gullino M.L.: Sustainable Development and Environmental Management: Experiences and Case Studies. Springer Science & Business Media. (2010)
- [Cluzel et al. 2015] Cluzel F., Yannou B., Millet D., Leroy Y.: Eco-ideation and eco-selection of R&D projects portfolio in complex systems industries. *Journal of Cleaner Production*. 2016;112:4329-4343.
- [COM 2008] Communication from the Commission to the Council and the European Parliament - Establishment of the working plan for 2009-2011 under the Ecodesign Directive, /\* COM/2008/0660 final \*/
- [COP21] United Nations Framework Convention on Climate Change, Taking the Paris Agreement forward, Reflections note by the President of the twenty-first session of the Conference of the Parties and the incoming President of the twenty-second session of the Conference of the Parties, 6 May 2016, [http://unfccc.int/paris\\_agreement/items/9485.php](http://unfccc.int/paris_agreement/items/9485.php). Accessed 12.06.2016
- [COSI 2015] Auer J.: Capstone Project Report: Analysis of the efficiency of the Ecodesign directive in regards to the political goal on climate change. CBS/KU/DTU course – Sustainability Challenges & Systems Thinking II: Specific Systems and capstone project. (2015)
- [Cowley and McGowan-Jackson 2015] Cowley, McGowan-Jackson: Kennecott Copper Environmental Profile, Life Cycle Assessment, Kennecott Utah Copper Corporation (2004)
- [Diaz et al., 2010] Diaz N., Helu M., Jayanathan S., Chen Y., Horvath A., & Dornfeld D.: Environmental Analysis of Milling Machine Tool Use in Various Manufacturing Environments. Conference: 2010 IEEE International Symposium on Sustainable Systems and Technology (ISSST). DOI: 10.1109/ISSST.2010.5507763
- [Diehm 2007] Diehm: IS machines: 80 years of continuous improvement. *Glass International*. 2007;30(6):23–6
- [Dijkman et al., 2015] Dijkman T.J., Rödger, J.-M., Bey, N.: How to assess sustainability in automated manufacturing. Proceedings of the 2015 Ieee International Conference on Automation Science and Engineering (case) — 2015;1351-1356. DOI 10.1109/CoASE.2015.7294286

- [DIN 2016] Deutsches Institut für Normung: DIN in Europa.  
<http://www.din.de/de/din-und-seine-partner/din-in-europa>. Accessed 06.11.16
- [Dinda 2004] Dinda S.: Environmental Kuznets Curve Hypothesis: A Survey. *Ecological Economics*. 2004;49:431–455
- [Dobranskyte-Niskota et al., 2007] Dobranskyte-Niskota, Perujo, Pregl: Indicators to assess sustainability of transport activities. European Commission. Joint Research Center, Institute for Environment and Sustainability, Ispra, Italy. (2007)
- [Drucker 2004] Drucker P.: Management, Taylor and Francis, St. Louis. 2004. Available from: ProQuest Ebook Central. Accessed 14.05.17
- [DTU 2017] Technical University of Denmark (DTU) Literature Database: <https://findit.dtu.dk/>. Listing of Databases: [http://api.libguides.com/api\\_box.php?iid=3935&bid=13937966](http://api.libguides.com/api_box.php?iid=3935&bid=13937966).
- [Duflou et al., 2012] Duflou JR, Sutherland JW, Dornfeld D, Herrmann C, Jeswiet J, Kara S, Hauschild M, Kellens K (2012) Towards Energy and Resource Efficient Manufacturing: A Processes and Systems Approach. *CIRP Annals - Manufacturing Technology* 61(2):587-609.
- [EC 2010] European Commission - Joint Research Centre - Institute for Environment and Sustainability: International Reference Life Cycle Data System (ILCD) Handbook - General guide for Life Cycle Assessment - Detailed guidance. First edition March 2010. EUR 24708 EN. Luxembourg. Publications Office of the European Union. (2010)
- [EC 2011] European Commission: A resource-efficient Europe – Flagship initiative under the Europe 2020 strategy, Communication from the Commission to the European Parliament, the Council, the European Economic and Social Committee and the Committee of Regions. (2011)
- [EC 2013a] European Commission: Building the Single Market for Green Products Facilitating better information on the environmental performance of products and organisations. Communication/\* COM/2013/0196 final \*/ (2013)
- [EC 2013b] 2013/179/EU: Commission Recommendation of 9 April 2013 on the use of common methods to measure and communicate the life cycle environmental performance of products and organisations. <http://data.europa.eu/eli/reco/2013/179/oj>. Accessed 13.03.2017

- [EC 2014a] European Commission, DG Energy, energy efficient products, electric motors, <https://ec.europa.eu/energy/en/topics/energy-efficiency/energy-efficient-products/electric-motors>, accessed on 27.06.2016 (2016)
- [EC 2014b] European Commission. Energy prices and costs in Europe. European Commission, Brussels, Belgium. (2014).
- [EC 2015a] European Commission, DG Energy: Energy-efficient products, electric motors. <https://ec.europa.eu/energy/en/topics/energy-efficient-products/electric-motors>. Accessed on 14.12.15
- [EC 2015b] European Commission/Press release"/Closing the loop: Commission adopts ambitious new Circular Economy Package to boost competitiveness, create jobs and generate sustainable growth", IP-15-6203, 02.12.2015, [http://europa.eu/rapid/press-release\\_IP-15-6203\\_en.htm](http://europa.eu/rapid/press-release_IP-15-6203_en.htm), accessed on 15.06.2016. (2015)
- [EC 2016] European Commission: Environmental Footprint Pilot Guidance document - Guidance for the implementation of the EU Product Environmental Footprint (PEF) during the Environmental Footprint (EF) pilot phase, version 5.2, February 2016 (2016)
- [Ehrenfeld, 2005] Ehrenfeld: Eco-efficiency – Philosophy, Theory, and Tools. *Journal of Industrial Ecology*. 2005;9(4):6–9.
- [Ehrenfeld, 2005] Ehrenfeld: Eco-efficiency – Philosophy, Theory, and Tools, *Journal of Industrial Ecology*, Vol. 9 (4), pp. 6 – 9. (2005)
- (Farla et al., 1997) Farla, Blok, Schipper: Energy efficiency developments in the pulp and paper industry – A cross-country comparison using physical production data, *Energy Policy*, Vol. 25, Nos. 7 – 9, pp. 745 – 758. (1997)
- [Ehrlich 1971] Ehrlich P., Holdren J.: Impact of Population Growth. *Science* (American Association for the Advancement of Science). 1971;171(3977):1212–1217
- [ElMaraghy 2015] ElMaraghy H.: Product Services Systems and Value Creation. *Proceedings of the 6th CIRP Conference on Industrial Product-Service Systems*. *Procedia CIRP*. 2014;16 [https://doi.org/10.1016/S2212-8271\(14\)00570-8](https://doi.org/10.1016/S2212-8271(14)00570-8)
- [EN 15804:2012] EN 15804:2012+A1:2013: Sustainability of construction works - Environmental product declarations - Core rules for the product category of construction products. (2012)
- [EN 50598-1] EN50598-1:2015, Ecodesign for power drive systems, motor starters, power electronics & their driven applications - Part 1: General requirements for setting energy efficiency standards for

power driven equipment using the extended product approach (EPA), and semi analytic model (SAM). (2015)

[EN 50598-2] EN50598-2:2015, Ecodesign for power drive systems, motor starters, power electronics & their driven applications - Part 2: Energy efficiency indicators for power drive systems and motor starters. (2015)

[EN 50598-3:2010] EN50598-3: Ecodesign for power drive systems, motor starters, power electronics and their driven applications - Part 3: Quantitative eco design approach through life cycle assessment including product category rules and the content of environmental declarations. (2015)

[EPAct 1992] Senate and House of Representatives of the United States of America in Congress assembled:Energy Policy Act 1992. Public Law 102-486-OCT. 24, 1992.

[EU 2014] Commission Regulation (EU) No 4/2014 of 6 January 2014 amending Regulation (EC) No 640/2009 implementing Directive 2005/32/EC of the European Parliament and of the Council with regard to ecodesign requirements for electric motors, OJ L 2, 7.1.2014, p. 1–2. (2014)

[EU 2015] [http://ec.europa.eu/eurostat/statistics-explained/index.php/Energy\\_price\\_statistics](http://ec.europa.eu/eurostat/statistics-explained/index.php/Energy_price_statistics); Accessed 08.10.2015.

[EU CI 2015] European Copper Institute: The environmental profile of copper products – A cradle to gate life-cycle-assessment for copper tube, sheet and wire produced in Europe, [www.copper-life-cycle.org](http://www.copper-life-cycle.org). Accessed 22.10.2015.

[Euribor 2014] Euribor: Euribor Interest rates. Retrieved May 2014, from [Euribor-rates.eu: www.euribor-rates.eu](http://www.euribor-rates.eu). Accessed 15.04.2014.

[Europe Scrap Prices 2014] Europe Scrap Prices. From Scrap Monster: <http://www.scrapmonster.com/european-scrap-prices>. Accessed 15.04.2014.

[Eurostat 2014] Eurostat: Electricity prices for industrial consumers. [http://ec.europa.eu/geninfo/legal\\_notices\\_en.htm](http://ec.europa.eu/geninfo/legal_notices_en.htm). Accessed 08.05.2014

[Forsyth 1996] Forsyth A.: ISO 14001: What does it mean for IEs? IIE Solutions. Jan. 1996;14-18.

[GaBi 2016] Thinkstep: GaBi Databases, <https://www.thinkstep.com/software/gabi-lca/gabi-databases>. Accessed 23.03.2016.

- [Gama & Herrmann, 2013] Gama M., Herrmann C.: Study Report – Relevance and Trends of Quantitative Environmental Product Information and EPDs. Commission by Siemens AG, Sector Industry to PE International AG. Leinfelden-Echterdingen, Germany.
- [GISTEMP 2015] GISTEMP Team, 2015: GISS Surface Temperature Analysis (GISTEMP). NASA Goddard Institute for Space Studies. <http://data.giss.nasa.gov/gistemp/>. Accessed 01.07.2016
- [Goetsch 1991] Goetsch David L.: Modern Manufacturing Processes (Book), Delmar Publishing Co ,U.S., ISBN: 0827-329288. (1991)
- [Goldemberg 1998] Goldemberg J.: Leapfrogging Energy Technologies. Energy Policy. 1998;26(10):729–741.
- [Greenhalgh 1997] Greenhalgh T.: How to read a paper: Papers that summarise other papers (systematic reviews and meta-analyses). BMJ. 1997;315:672.
- [Groover 2010] Groover, M.P.: Fundamentals of modern manufacturing: Materials, processes and systems, 4th ed. (Book). John Wiley & Sons Inc., U.S., ISBN: 978-0470-467002. (2010)
- [Groover 2012] Groover M.P.: Introduction to manufacturing processes (Book), John Wiley & Sons Inc., U.S., ISBN: 978-0470-632284. (2012)
- [Guinée et al., 2001] Guinée J.B., Huppes G., Heijungs R.: Developing an LCA guide for decision support. Environmental Management and Health. 2001;12 (3):301-311. doi: 10.1108/09566160110392416
- [Hall et al., 2003] Hall J., and Vredenburg H.: The Challenges of Innovating for Sustainable Development. MIT SLOAN Management Review Fall 2003
- [Hansen 2010] Hansen J., Ruedy R., Sato M., and Lo K.: Global surface temperature change. Rev. Geophys. 2010;48(4), RG4004. doi:10.1029/2010RG000345.
- [Hauschild et al., 2005] Hauschild, Jeswiet, Alting: From Life Cycle Assessment to Sustainable Production: Status and Perspectives. CIRP Annals – Manufacturing Tech-nology. 2005;54(2):1–21
- [Heijungs et al., 2013] Heijungs R., Settanni E., Guinee J.: Toward a computational structure for life cycle sustainability analysis: unifying LCA and LCC. International Journal of Life Cycle Assessment. 2013;18(9):1722-1733



- [Henriksen, Ponte 2015] Henriksen L.F., Ponte S.: Form Farm to Flight: Orchestration, Social Networks and the Transnational Environmental Governance of Aviation. Proceedings of Regulatory Intermediates: Bringing together Domestic and Transnational Regulation, SASE, London 2-4 July 2015. Tbp.
- [Herrmann et al., 2012] Herrmann, Gama, Helman: Calculating the carbon footprint of electronic products with life cycle assessment. PE International white paper. Stuttgart, Germany. (2012)
- [Hirzel et al., 2014] Hirzel, Hettesheimer, Schroeter: Electric or pneumatic? Comparing electric and pneumatic linear drives with regard to energy efficiency and costs. Proceedings of the ecee 2014 Industrial Summer Study on energy efficiency. Arnhem, Netherlands. 2014;1:475 – 485
- [Hoogmartens et al., 2014] Hoogmartens R., Van Passel S., Van Acker K., Dubois M.: Bridging the gap between LCA, LCC and CBA as sustainability assessment tools. Environmental Impact Assessment Review. 2014;48:27-33
- [Hui and Mohammed, 2015] Hui, Mohammed: The Role of Cost Breakdown Structure in Life Cycle Cost Model. Jurnal Teknologi. 2015; 74(2):117–121
- [Huijbregts 2001] Huijbregts: Uncertainty and variability in environmental life cycle assessment, PhD thesis, Institute for Biodiversity and Ecosystem Dynamics, University of Amsterdam. (2001)
- [Huijbregts et al. 2000] Huijbregts, Thissen, Jager, van de Meent, Ragas: Priority assessment of toxic substances in life cycle assessment. Part II: assessing parameter uncertainty and human variability in the calculation of toxicity potentials, Chemosphere. 2000;41:575-588.
- [Huijbregts et al. 2003] Huijbregts, Lundi, McKone, van de Meent: Geographical scenario uncertainty in generic fate and exposure factors of toxic pollutants for life-cycle impact assessment, Chemosphere. 2003;51:501-508.
- [Hülsemeyer et al., 2015] Denkena, Helmecke, Hülsemeyer: Energy efficient machining of Ti-6Al-4V, CIRP Annals – Manufacturing Technology. 2015;64:61–64.
- [Huppel & Ishikawa, 2007] Huppel, Ishikawa: An introduction to quantified eco-efficiency analysis, Eco-efficiency in industry and science, Vol. 22, Quantified Eco-Efficiency – An Introduction with Applications, Chapter 1, pp. 1 – 38, Springer Netherlands. (2007)

- [IEC 2010] International Electrotechnical Commission: Welcome to IEC (brochure). Geneva, Switzerland.  
[http://www.iec.ch/about/brochures/pdf/about\\_iec/iec\\_welcome\\_en\\_2010\\_lr.pdf](http://www.iec.ch/about/brochures/pdf/about_iec/iec_welcome_en_2010_lr.pdf). Accessed 05.11.16
- [IEC 2014] IEC/ISO 62959 ED1: Environmental Conscious Design (ECD) - Principles, requirements and guidance. 1<sup>st</sup> Committee Draft 2016. Development of ISO/IEC double logo standard.  
[http://www.iec.ch/dyn/www/f?p=103:38:5710052205795:::FSP\\_ORG\\_ID,FSP\\_APEX\\_PAGE,FSP\\_PROJECT\\_ID:1314,23,21932](http://www.iec.ch/dyn/www/f?p=103:38:5710052205795:::FSP_ORG_ID,FSP_APEX_PAGE,FSP_PROJECT_ID:1314,23,21932). Accessed 03.05.2017.
- [IEC 60034-30-1] IEC 60034-30-1:2014, Rotating electrical machines – Part 30-1: Efficiency classes of line operated AC motors (IE code). (2014)
- [IEC 62321:2008] IEC 62321: Electrotechnical products - Determination of levels of six regulated substances (lead, mercury, cadmium, hexavalent chromium, polybrominated biphenyls, polybrominated diphenyl ethers). (2008)
- [IEC 62430:2009] IEC 62430: Environmentally conscious design for electrical and electronic products. IEC/TC111. (2009)
- [IEC 62474:2012] IEC 62474: Material declaration for products of and for the electrotechnical industry. (2012)
- [IEC Guide 109:2012] IEC GUIDE 109: Environmental aspects – Inclusion in electrotechnical product standards. (2012)
- [IEC/CLC 2016] International Electrotechnical Commission (IEC), European Committee for Electrotechnical Standardisation (CENELEC): IEC-CENELEC Frankfurt Agreement. (2016)
- [IEC/TR62635:2012] IEC/TR 62635: Guidelines for End of Life information provision from manufacturers and recyclers, and for recyclability rate calculation of Electrical and Electronic Equipment (2012)
- [ILCD 2011] ILCD Handbook: Recommendations for Life Cycle Impact Assessment in the European context, EUR 24571 EN – 2011, <http://eplca.jrc.ec.europa.eu/uploads/ILCD-Recommendation-of-methods-for-LCIA-def.pdf>, accessed on 05.11.2015 (2011)
- [ISO 14006:2011] Environmental management systems – Guidelines for incorporating ecodesign. 2011
- [ISO 14020:2000] ISO 14020: Environmental labels and declarations - General principles. (2000)

- [ISO 14024:1999] ISO 14024: Environmental labels and declarations - Type I environmental labelling - Principles and procedures. (1999)
- [ISO 14025:2006] ISO 14025: Environmental labels and declarations - Type III environmental declarations - Principles and procedures. (2006)
- [ISO 14040:2006] ISO 14040:2006, Environmental management - Life cycle assessment - Principles and framework. (2006)
- [ISO 14044:2006] ISO 14044: 2006, Environmental management - Life cycle assessment - Requirements and guidelines. (2006)
- [ISO 14045:2012] ISO 14045: Environmental management - Eco-efficiency assessment of product systems - Principles, requirements and guidelines. (2012)
- [ISO 14067:2013] ISO/TS 14067: Greenhouse gases - Carbon footprint of products - Requirements and guidelines for quantification and communication. (2013)
- [ISO 2012] International Standardisation Organisation (ISO): Environmental labelling and declarations – How ISO standards help (Borchure). Geneva, Switzerland. ISBN 978-92-67-10586-4. (2012)
- [ISO 2015] International Organization for Standardisation: ISO in brief (brochure). Geneva, Switzerland. ISBN 978-92-67-10637-3. (2015)
- [ISO 2016] International Organization for Standardisation: ISO Strategy 2016-2020 (brochure). Geneva, Switzerland. ISBN 978-92-67-10638-0. (2016)
- [ISO Guide 64:2008] Guide for addressing environmental issues in product standards. 2008
- [ISO TR 14062:2002] ISO/TR 14062: Environmental management - Integrating environmental aspects into product design and development. ISO/TC207. (2002)
- [ISO/CEN 1991] International Organization for Standardisation (ISO), European Committee for Standardisation (CEN): Agreement on technical co-operation between ISO and CEN (Vienna Agreement). (1991)
- [Jayal et al., 2010] Jayal AD, Badurdeen F, Dillon Jr OW, Jawahir IS (2010) Sustainable Manufacturing: Modeling and Optimization Challenges at the Product, Process and System Levels. CIRP Journal of Manufacturing Science and Technology 2: 144–152.
- [Jugend et al., 2016] Chiappeta Jabbour Ch. J., de Souza F. B., Jugend D., Luiz O. R, Rojas Luiz J. V.: Ecodesign field of research throughout

- the world: mapping the territory by using an evolutionary lens. *Scientometrics*. 2016;109:241-259.
- [Junnila 2008] Junnila S.: Life cycle management of energy-consuming products in companies using IO-LCA. *International Journal of Life Cycle Assessment*. 2008;13:432-439.
- [Kádárová et al., 2015] Kádárová, Koblunický, Teplicka: Product Life Cycle Costing. *Applied Mechanics and Materials*. 2015;81(6):547-554
- [Karlsson and Järrehed, 2000] Karlsson, Järrehed: Recycling of electrical motors by automatic disassembly, *Meas. Sci. Technol.* 2000;11:350-357
- [Kasper et al., 2015] Kasper, A.C., Gabriel, A.P., de Oliveira, E.L.B., de Freitas Juchneski, N.C., Veit, H.M.: Electronic Waste Recycling, H.M. Veit and A. Moura Bernardes (eds.), *Electronic Waste, Topics in Mining, Metallurgy and Materials Engineering*, DOI 10.1007/978-3-319-15714-6\_9. (2015)
- [Kauffman & Lee, 2013] Kauffman J., & Lee K.-M. (eds.): *Handbook of Sustainable Engineering*. ISBN 978-1-4020-8938-1. DOI 10.1007/978-1-4020-8939-8. Springer Science+Business Media. Dordrecht, Netherlands. (2013)
- [Kellenberger & Althaus, 2009] Kellenberger D., & Althaus H.-J.: Relevance of simplifications in LCA of building components. *Building and Environment*. 2009;44:818-825
- [Laurent and Hauschild, 2015] Laurent, Hauschild: Normalisation, Chapter 14 of M.Z. Hauschild, M.A.J. Huijbregts (eds.), *Life Cycle Impact Assessment, LCA Compendium – The Complete World of Life Cycle Assessment*, DOI 10.1007/978-94-017-9744-3\_14. (2015)
- [Lemmens and Deprez 2012] Sumper, Baggini: *Electrical Energy Efficiency: Technologies and Applications*, First Edition, Chapter 7 – Joris Lemmens and Wim Deprez: *Electric Motors*. (2012)
- [Li 2012] Li, W.: Energy and eco-efficiency of manufacturing processes. PhD thesis. Mechanical & Manufacturing Engineering, Faculty of Engineering, UNSW. University of South-Wales, Australia. <http://handle.unsw.edu.au/1959.4/52333>. (2012)
- [Li et al., 2015] Li J., Stevels A., Zeng X.: Ecodesign in Consumer Electronics: Past, Present and Future. *Critical Reviews in Environmental Science and Technology*. 2015;45:840-860.
- [Lindahl et al., 2014] Lindahl, Sundin, Sakao: Environmental and Economic Benefits of Integrated Product-Service Offerings Quantified with

- Real Business Cases. *Journal of Cleaner Production*. 2014;64:288–296.
- [Lindqvist 2012] Lindqvist, Å: Life Cycle Cost Analysis - Eco-Island ferry. Sweden: SP Technical Research Institute. (2012)
- [Lister et al., 2015] Lister J., Toudal Poulsen R., Ponte S.: Orchestrating transnational environmental governance in maritime shipping. *Global Environmental Change*. 2015;34(9):185-195
- [Mao et al., 2013] Mao, Zeng, Hu, Zhou, Xing, Liu: Co-control of local air pollutants and CO<sub>2</sub> in the Chinese iron and steel industry, *Environ. Science Technology*. 2013;47(21): 12002–12020.
- [Marilungo et al., 2016] Marilungo E., Coscia E., Quaglia A., Peruzzini M., Germani M.: Open Innovation for ideating and designing new Product Service Systems. *Procedia CIRP*. 2016;47:305-310.
- [Marsh, 2012] Marsh P.: *The New Industrial Revolution – consumers, globalization and the end of mass production*. Yale University Press, New Haven and London. ISBN 978-0-300-11777-6. (2012)
- [Mathieux et al., 2007] Brissaud D., Mathieux F., Zwolinski P.: Product ecodesign and materials: current status and future prospect, Paper presented at the 1st International seminar on Society & Materials, Seville. (2007)
- [McAloone & Bey, 2009] McAloone T, Bey N: Environmental improvement through product development – A guide. Danish Environmental Protection Agency. (2009)
- [McDonough & Braungart 2002] McDonough W., & Braungart M.: *Cradle to cradle —Remaking the way we make things*. North Point Press. New York, NY, USA. (2002)
- [McKinsey 2011] McKinsey: *The Business of Sustainability 2011*. <http://www.mckinsey.com/business-functions/sustainability-and-resource-productivity/our-insights/the-business-of-sustainability-mckinsey-global-survey-results>. Accessed 04.05.16
- [MEErP 2011] VHK for European Commission. Methodolgy Report 2011, Final. Methodology for Ecodesign of Energy-related Products (MEErP). Brussels/ Delft: René Kemna.
- [Meier et al., 2010] Meier, Roy, Seliger: Industrial Product-Service Systems – IDS<sup>2</sup>. *Annals of CIRP*. 2010;59(2):607–627.
- [Meincke 2012] Meincke A.: *Produktumwelterklärung nach EN ISO 14025 für den Antriebsstrang der U-Bahn München (C2)*. Diplomarbeit.

- Hochschule Zittau-Görlitz, Fachbereich Energie- und Umwelttechnik. (2013)
- [Moah and Kanaroglou, 2009] Moah, Kanaroglou: A Tool for Evaluating Urban Sustainability via Integrated Transportation and Land Use Simulation Models. *Urban Environment*. 2009;3:28–46.
- [Nambiar, 2010] Nambiar: Challenges in Sustainable Manufacturing, Proceedings of the 2010 International Conference on Industrial Engineering and Operations Management, lecture 266, Dhaka, Bangladesh. (2010)
- [Nielsen & Wenzel, 2002] Nielsen PH, Wenzel H.: Integration of environmental aspects in product development: a stepwise procedure based on quantitative life cycle assessment, *Journal of Cleaner Production*. 2002;10(3):247-257.
- [Oerskes 2004] Oreskes N.: Behind the Ivory Tower: The Scientific Consensus on Climate Change. *Science*. 2004;306(5702).
- [Paquette 2011] Paquette J.K.: *The Glassmakers, Revisited: A History of Owens-Illinois, Inc.* (Book). Revised edition 2011. Xlibris Corporation, Bloomington, US. ISBN 978-1-4500-7544-2. (2011)
- [Pennington 1999] Pennington: Letters to the Editor, Comment and Reply, Comment: Uncertainty in LCIA of Toxic Releases, *Int. J. LCA*. 1999;4(2):62-64.
- [Pigosso et al., 2013] Pigosso D.C.A., Rozenfeld H., McAloone T.C.: Ecodesign maturity model: A management framework to support ecodesign implementation into manufacturing companies. *Journal of Cleaner Production*. 2013;59(15):160-173.
- [Pigosso et al., 2015] McAloone T. C., Pigosso D. C. A., Rozenfeld H.: Characterization of the State-of-the-art and Identification of Main Trends for Ecodesign Tools and Methods: Classifying Three Decades of Research and Implementation. *Indian Institute of Science*. 2015;94:405-427.
- [Plenert 1994] Plenert G.: The generalized process manufacturing systems package. *Production Planning and Control*. 1994;5(5):494-498
- [Pulselli et al., 2009] Pulselli, Ridolfi, Rugani, Tiezzi: Application of life cycle assessment to the production of man-made crystal glass. *International Journal of Life Cycle Assessment*. 2009;14:490–501.
- [Recchioni et al., 2007] Recchioni M., Mandorli F., Germani M., Faraldi P., Polverini D.: Life-Cycle Assessment simplification for modular products. In: Takata S., Umeda Y. (eds) *Advances in Life Cycle*

Engineering for Sustainable Manufacturing Businesses. Springer, London. (2007)

- [Roach 2004] Roach J.: 2004: The year global warming got respect. National Geographic News: Reporting Your World Daily, December 29, 2004.  
[http://news.nationalgeographic.com/news/2004/12/1229\\_041229\\_climate\\_change\\_consensus.html](http://news.nationalgeographic.com/news/2004/12/1229_041229_climate_change_consensus.html); Accessed on 07.01.2016
- [Rockström et al., 2009] Rockström J., Steffen W., Noone K., Persson Å., Chapin III F. S., Lambin E., Lenton T. M., Scheffer M., Folke C., Schellnhuber H., Nykvist B., De Wit C. A., Hughes T., van der Leeuw S., Rodhe H., Sörlin S., Snyder P. K., Costanza R., Svedin U., Falkenmark M., Karlberg L., Corell R. W., Fabry V. J., Hansen J., Walker B., Liverman D., Richardson K., Crutzen P., Foley J.: Planetary boundaries: exploring the safe operating space for humanity. *Ecology and Society*. 2009;14(2):32.
- [Rödger et al., 2016] Rödger, J.-M., Bey, N., Alting, L.: The Sustainability Cone – A holistic framework to integrate sustainability thinking into manufacturing. *CIRP Annals - Manufacturing Technology*. 2016;65(1):1-4.
- [Rondinelli & Vastag 2000] Rondinelli D., & Vastag G.: Panacea, Common Sense, or Just a Label? The Value of ISO 14001 Environmental Management Systems. *European Management Journal*. 2000;18(5):499–510
- [Rosenbaum et al. 2008] Rosenbaum, Bachmann, Swirsky Gold, Huijbregts, Jolliet, Juraske, Koehler, Larsen, MacLeod, Margni, McKone, Payet, Schuhmacher, van de Meent, Hauschild: UESTox – the UNEP-SETC toxicity model: recommended characterisation factors for human toxicity and freshwater ecotoxicity in life cycle impact assessment, *Int J Life Cycle Assess*. 2008;13:532-546
- [Röttjes 2012] Röttjes S.: Parameterized LCA model of motors with GabiDfx. Bachelorthesis. University of Applied Science Darmstadt, Fachbereich Elektrotechnik und Informationstechnik & Siemens AG. (2012)
- [Roy 1994] Roy R.: The evolution of eco-design. *Technovation*. 1994;14:363-380.
- [Ruffino & Zanetti, 2008] Ruffino B. & Zanetti M.C.: Recycling of steel from grinding scraps: Reclamation plant design. *Resources, Conservation and Recycling*. 2008;52:1315–1321.

- [Ryberg et al., 2016] Ryberg M., Owsianiak M., Richardson K., & Hauschild M.Z.: Challenges in implementing a Planetary Boundaries based Life-Cycle Impact Assessment methodology. *Journal of Cleaner Production*. 2016;139:450-459. DOI: 10.1016/j.jclepro.2016.08.074
- [Sarapulov et al., 2015] Linkov, Olizarenko, Radionov, Sarapulov: Energy-efficient power supply systems for mines, *International Conference on Industrial Engineering*. *Procedia Engineering*. 2015;129:63–68.
- [Schneider et al., 2015] Schneider, Berger, Finkbeiner: Abiotic resource depletion in LCA – background and update of the anthropogenic stock extended abiotic depletion potential (AADP) model, *Int J Life Cycle Assess*. 2015;20:709-721.
- [SEC 2011] COMMISSION STAFF WORKING DOCUMENT IMPACT ASSESSMENT, Accompanying document to the COMMUNICATION FROM THE COMMISSION TO THE EUROPEAN PARLIAMENT, THE COUNCIL, THE EUROPEAN ECONOMIC AND SOCIAL COMMITTEE AND THE COMMITTEE OF THE REGIONS COMMISSION STAFF WORKING DOCUMENT, Energy Efficiency Plan 2011, SEC(2011) 277 final
- [Shu-Yang et al., 2004] Shu-Yang F., Freedman B., Cote R.: Principles and practice of ecological design. *Environ. Rev*. 2004;12:97–112.
- [Siemens 2010] Siemens AG, CHR EHS & CT T DE HW5: Eco-Care-Matrix – Short Description. Siemens internal guideline. 2010
- [Siemens 2011] Siemens AG: Pictures of the Future, Fall 2011: Eco-Care Matrix.  
[http://www.siemens.com/innovation/apps/pof\\_microsite/pof-fall-2011/html/en/environmental-analyses.html](http://www.siemens.com/innovation/apps/pof_microsite/pof-fall-2011/html/en/environmental-analyses.html). Siemens AG, Munich, Germany. Accessed 14.04.2014.
- [Siemens 2013a] Siemens AG: 5,000,000 kilowatts of installed expertise. Innovative FLENDER vertical mill drives for grinding coal, raw meal, slag and clinker (Brochure). Bocholt, Germany. 2013. Order-Nr.: E20001-A370-P900-X-7600. [siemens.com/verticalmilldrives](http://siemens.com/verticalmilldrives). Accessed 16.05.2014
- [Siemens 2013b] Siemens AG: Compact, flexible, highest reliability - SIMOTICS HV and SIMOTICS TN series H-compact PLUS (Brochure). Nurnberg, Germany. 2013. Article No: E20001-A280-P530-V1-7600. [siemens.com/simotics](http://siemens.com/simotics). Accessed 16.05.2014
- [Siemens 2013c] Siemens AG: SINAMICS Perfect Harmony - The Air-Cooled Medium Voltage Drive of Choice (Brochure). Nurnberg,



- Germany. 2013. Article No.: E20001-A30-P590-V2-7600.  
 siemens.com/sinamics-perfect-harmony. Accessed 17.05.2014
- [Siemens 2013d] Siemens AG, DT: Integrated Drive Systems – Was steckt dahinter/What’s behind it. IDS\_Internal\_2013.ppt. Siemens, internal presentation. 2013
- [Siemens 2013e] Siemens AG, DT: Integrated Drive Systems: Shift your perspective – there’s more to it! 5416\_IDS\_External.ppt. Siemens, external presentation. 2013
- [Siemens 2014a] Reuss, Georg: Energy-saving glass pressing. Siemens Advance. 2014;3:16–17.  
[www.industry.siemens.com/topics/global/en/magazines/advance/advance-archive/Documents/advance-2014-3-en.pdf](http://www.industry.siemens.com/topics/global/en/magazines/advance/advance-archive/Documents/advance-2014-3-en.pdf). Accessed 18.05.2015
- [Siemens 2014b] Siemens AG: FLENDER Gear Units for Vertical Mills. Siemens Industry Inc. Global Website:  
<http://www.industry.usa.siemens.com/drives/us/en/gear-motors-couplings/gear-units/application-specific-gear-reducers/content-gear-reducers/Pages/Vertical-Mills.aspx>. Accessed 05.07.2014
- [Siemens 2014c] Siemens AG: Flender Multiple Drive.  
<http://w3.siemens.com/drives/global/en/gear-units/application-specific-gear-units/vertical-mills/flender-multiple-drive/Pages/Default.aspx>. Accessed 16.05.2014
- [Siemens 2015a] Siemens: 40 % energy savings with integrated drive systems. blogs.siemens.com/competitive-industries/stories/830-40-percent-energy-savings-with-integrated-drive-systems. Accessed on 14.12.2015
- [Siemens 2015b] Integrated Drive System:  
<http://www.industry.siemens.com/topics/global/en/integrated-drive-systems/Pages/default.aspx>; Accessed 04.05.16
- [Siemens 2016a] Siemens PD:  
<http://www.siemens.com/about/en/businesses/process-industries-and-drives.htm>; Accessed 04.05.16
- [Siemens 2016c] Siemens Sustainability & Citizenship:  
<http://www.siemens.com/about/sustainability/en/index.php>
- [Siemens 2016d] Siemens Sustainability Information 2015:  
[http://www.siemens.com/about/sustainability/pool/en/current-reporting/siemens\\_sustainability\\_information2015.pdf](http://www.siemens.com/about/sustainability/pool/en/current-reporting/siemens_sustainability_information2015.pdf); Accessed 04.05.16

- [Siemens 2016e] Siemens Circular No. 171 “Principles of Environmental Protection, Health Management and Safety”; Intranet: [https://circulars.siemens.com/documents/circulardownload.aspx?id=sc\\_171.pdf](https://circulars.siemens.com/documents/circulardownload.aspx?id=sc_171.pdf); Accessed 04.05.16
- [Siemens 2016f] Siemens AG: Siemens receives top marks in world’s largest climate-protection ranking; <https://www.siemens.com/press/PR2015110069COEN>; Accessed 04.05.16
- [Siemens 2016g] Siemens AG: Siemens to be climate neutral by 2030; [http://www.siemens.com/press/en/feature/2015/corporate/2015-09-co2-neutral.php?content\[\]=Corp](http://www.siemens.com/press/en/feature/2015/corporate/2015-09-co2-neutral.php?content[]=Corp); Accessed 04.05.16
- [Siemens 2016h]Siemens AG: DFPD63: Environmentally-conscious product design, environmental aspects and material declaration; Intranet: [https://circulars.siemens.com/documents/circulardownload.aspx?id=dfpd63\\_en.pdf](https://circulars.siemens.com/documents/circulardownload.aspx?id=dfpd63_en.pdf); Accessed 04.05.16
- [Siemens 2017a] Siemens AG: <http://www.siemens.com/about/en/>; Accessed 01.05.17
- [Siemens 2017b] Siemens AG: Annual Report 2016, <https://www.siemens.com/content/dam/internet/siemens-com/global/company/about/downloads/siemens-ar2016.pdf>; Accessed 01.05.17
- [Siemens PD 2015] Siemens PD: Global EHS Program (FY15-FY20) – Product Eco Excellence. Internal Announcement.
- [SIZER 2015] Siemens: SIZER for Siemens drives, [w3.siemens.com/mcms/mc-solutions/en/engineering-software/drive-design-tool-sizer/Pages/drive-design-tool-sizer.aspx](http://w3.siemens.com/mcms/mc-solutions/en/engineering-software/drive-design-tool-sizer/Pages/drive-design-tool-sizer.aspx). Accessed 16.12.2015
- [Sklostroj 2015] Sklostroj: IS Machines. [www.sklostroj.cz/userfiles/file/AL/IS%20Machines.pdf](http://www.sklostroj.cz/userfiles/file/AL/IS%20Machines.pdf). Accessed on 14.12.2015
- [Sleeswijk et al., 2007] Sleeswijk, van Oers, Guinée, Struijs, Huijbergts: Normalisation in product life cycle assessment: An LCA of the global and European economic systems in the year 2000. *Science of the Total Environment*. 2008;390
- [Smith 2011] Smith, Cecil: Things to Watch Out for with Variable-Speed Pumps. [www.sustainableplant.com/2011/04/things-to-watch-out-for-with-variable-speed-pumps/Tab/Article](http://www.sustainableplant.com/2011/04/things-to-watch-out-for-with-variable-speed-pumps/Tab/Article). Accessed 15.12.2015

- [Steffen et al., 2015] Steffen W., Richardson K., Rockstrom J., Cornell S.E., Fetzer I., Bennett EM et al: Planetary boundaries: guiding human development on a changing planet. *Science*. 2015;347:736.
- [Stevens 2001] Stevens A: Application of EcoDesign - Ten years of dynamic development. Second International Symposium on Environmentally Conscious Design and Inverse Manufacturing. 2001;905-915.
- [Süß 2007] Süß: Hauptumweltkriterium im Lebenszyklus eines Schützes (German), Masterthesis, HAW Amberg-Weiden. (2007)
- [SWD 2012] Establishment of the Working Plan 2012-2014 under the Ecodesign Directive. {SWD(2012) 434 final}.
- [SWD 2014] COMMUNICATION FROM THE COMMISSION TO THE EUROPEAN PARLIAMENT AND THE COUNCIL: Energy Efficiency and its contribution to energy security and the 2030 Framework for climate and energy policy. {SWD(2014) 255 final}, {SWD(2014) 256 final}.
- [Telenko et al., 2016] O'Rourke J. M., Seepersad C. C., Telenko C., Webber, M.E.: A Compilation of Design for Environment Guidelines. *Journal of Mechanical Design*. 2016;138: 031-102.
- [Thinkstep 2015] Thinkstep: GaBi Software, [www.gabi-software.com/international/index/](http://www.gabi-software.com/international/index/). Accessed on 12.12.2015.
- [Thomas 2012] Thomas A.: Fixed Speed Drives – Energy Efficiency. Special print from etz special edition S4/2011, Siemens AG, Fürth, Germany. Order No. E20001-A250-P301-X-7600. (2012)
- [Trifonova & Ishun’kina 2007] Trifonova, & Ishun’kina: Eco-compatibility assessment of container glass production, *Ecological Issues. Glass and Ceramics*. 2007;64(5–6): 214–217
- [van den Hoven et al., 2015] van den Hoven J., et al. (eds.): *Handbook of Ethics, Values, and Technological Design*. Springer Science+Business Media. Dordrecht, Netherlands. (2015)
- [VDA 231-106:1997] Verband der Automobilindustrie e.V.: VDA 231-106: Material Classification In Motor Vehicle Construction - Structure And Nomenclature. (1997)
- [Vergheese & Hes 2007] Vergheese K., Hes D.: Note from the field – Qualitative and quantitative tool development to support environmentally responsible decisions. *Journal of Cleaner Production*. 2007;15:814-818.

- [Vezzoli & Manzini, 2008] Vezzoli C. & Manzini E. (eds.): Design for Environmental Sustainability. Springer-Verlag London Limited. ISBN 978-1-84800-162-6. DOI 10.1007/978-1-84800-163-3. (2008)
- [Volz 2010] Volz: Ratgeber Elektrische Motoren in Industrie und Gewerbe: Energieeffizienz und Ökodesign-Richtlinie. Deutsche Energie-Agentur GmbH (dena). (2010)
- [Wegener et al., 2009] Wegener, Finkbeiner, Geiger, Olsen, Walachowicz: Comprehensive Approach to Energy and Environment in the Eco Care Program for Design, Engineering and Operation of Siemens Industry Solutions. RISO International Energy Conference. 2009:45-52
- [Wegener et al., 2011] Wegener D., Finkbeiner M., Holst J-C., Olsen S. I., & Walachowicz F.: Improving Energy Efficiency in Industrial Solutions – Walk the Talk. In Energy Systems and Technologies for the Coming Century: Proceedings. Risø International Energy Conference. 2011;187-196. (Denmark. Forskningscenter Risoe. Risoe-R; No. 1776(EN)).
- [Wegener Sleeswijk et al., 2008] Wegener Sleeswijk A., van Oers L.F.C.M., Guinée J.B., Struijs J., Huijbregts M.A.J.: Normalisation in product life cycle assessment: An LCA of the global and European economic systems in the year 2000. Science of The Total Environment. 2008;390(1):227-40
- [Wenzel et al., 1997] Wenzel H., Hauschild M.Z., Alting L.: Environmental Assessment of Products, Volume 1: Methodology, tools and case studies in product development. Springer US. ISBN: 978-0-7923-7859-4. (1997)
- [Widiyanto et al., 2002] Widiyanto A., Kato S., Maruyama N.A.: LCA/LCC optimized selection of power plant system with additional facilities options. Journal of Energy Resources Technology-transactions of the Asme. 2002;124(4):290-299
- [Wikipedia 2017a] Wikipedia, the free online encyclopedia, entry on ‘Eco Design’. <https://en.wikipedia.org/wiki/Ecodesign>. Accessed 08.05.2017.
- [Wikipedia 2017b] Wikipedia, the free online encyclopedia, entry on ‘Sustainable Design’. [https://en.wikipedia.org/wiki/Sustainable\\_design](https://en.wikipedia.org/wiki/Sustainable_design). Accessed 08.05.2017.

- [Wimmer et al., 2014] Wimmer et al.: “Ecodesign PILOT”, 2002-2014. <http://www.ecodesign.at/pilot/ONLINE/ENGLISH/>. TU Vienna, Austria. (2014)
- [Woodward 1997] Woodward: Life cycle costing – theory, information acquisition and application. *International Journal of Project Management*. 1997;15(6):335-344
- [Yousnadj et al., 2014] Yousnadj D., Jouanne G., Maranzana N., Segonds F., Bouchard C., Aoussat A.: Integration of Environmental Assessment in a PLM Context: A Case Study in Luxury Industry. In: Fukuda S., Bernard A., Gurumoorthy B., Bouras A. (eds): *Product Lifecycle Management for a Global Market*. PLM 2014. IFIP Advances in Information and Communication Technology. Springer, Berlin, Heidelberg. (2014)
- [ZVEI 2011] ZVEI LCE tool:  
[www.zvei.org/en/association/publications/Pages/Energy-Efficiency-Pays-Off.aspx](http://www.zvei.org/en/association/publications/Pages/Energy-Efficiency-Pays-Off.aspx); Accessed on 11.11.2015

# ANNEX A: MASTER THESIS ABSTRACTS

<b>Ref.: R-I</b>	<b>Title</b>	Parameterized LCA modelling of Converters with GABI DfX		
<b>Author</b>	Stefanie Kotulla	Claudia	<b>Date</b>	September 2011
<b>Abstract</b>				
<p>The goal of this study was to obtain knowledge about the environmental impacts of converters manufactured by Siemens AG in Erlangen by carrying out a Life Cycle Assessment (LCA) according to ISO 14040. Several representative types of Sinamics S 120 motor modules were analysed in order to develop a parameterized model. As a result of this assessment, a number of approaches to ecodesign were identified and several waste scenarios were compared.</p> <p>The usage phase was identified as the dominant life cycle phase and included the most significant potential to reduce environmental impact. Further approaches to ecodesign are considered in the investigation and development of the heat sink and electronics. The recyclability was already considered in the design of the device and requires no further approaches to change. Thus, high rates of recycling are possible which reduces the environmental impacts.</p>				
<b>Institution</b>	University of applied science (FH) Amberg-Weiden; Faculty of Mechanical Engineering and Environmental Engineering			
<b>Supervisor(s)</b>	Prof. Dr. Burkhard Berninger; Prof. Dr. Markus Brautsch  Dipl.-Ing. (Univ.) Johannes Auer			

<b>Ref.: R-II</b>	<b>Title</b>	Elaboration of a parameterized LCA model of the 1FK7 servo motor product family according to ISO 14040 with the software GaBi 4 DfX	
<b>Author</b>	Steffen Lömmer	<b>Date</b>	October 2012
<b>Abstract</b>			
<p>Background: The goal of this life cycle assessment of representative servo drives of the 1FK7 product line from the Motion Control Systems portfolio (Manufacturing Site: Bad Neustadt/Saale) by means of the GaBi software in accordance to ISO 14040 is to identify the origin of environmental impacts during the product's life cycle. Based on the results of the impact assessment eco-design proposals are developed: In addition, a parameterised model based on few motor specifications for deriving environmental impact information is developed.</p> <p>Results: The usage phase was identified as dominant life cycle stage, hence the highest potential in reducing environmental impacts. The design and best motor selection according to the individual application is one promising field of interest. The manufacturing phase can realise eco-design potentials in applying materials with high recycling rates and further enhancement in electronic components. Based on parameters such as torque and motor weight, a linearized model for the manufacturing and end of life phase was developed to de-rive environmental impact information for other 1FK7 motors. This model was validated in an additional LCA.</p>			
<b>Institution</b>	University of applied science (FH) Würzburg-Schweinfurt; Faculty of Mechanical Engineering;		
<b>Supervisor(s)</b>	Prof. Dr. Thomas Blotevogel; Prof. Dr. Johannes Paulus  Dipl.-Ing. (Univ.) Johannes Auer		

<b>Ref.: R-III</b>	<b>Title</b>	Elaboration of a parameterized life cycle assessment of electric motors of the product family 1PH8 with evaluation of end-of-life scenarios	
<b>Author</b>	Philipp Knauf	<b>Date</b>	February 2014
<b>Abstract</b>			
<p>This master thesis contains the life cycle assessment of 1PH8 electric motors and a rating of end of life scenarios.</p> <p>The life cycle assessment (LCA) for representative engines from the product portfolio 1PH8 from the business unit Motion Control Systems which is located in Bad Neustadt was made in accordance to ISO 14040 with the software GaBi DfX. The usage phase is recognized as the dominant phase in the life cycle and thus represents the phase with the highest potential for reducing environmental impacts. In addition the impacts of different engines during this phase were simulated at an application with the program SIZER and afterwards compared in an Eco Care Matrix. For the end of life phase different possibilities for returning the examined motors are evaluated. A special evaluation is done for the synchronous motors, because the magnets consist to 30 % of the rare earth metal neodymium.</p>			
<b>Institution</b>	University of applied science (FH) Ansbach; Faculty of economic and general science; Department for energy management and energy technologies		
<b>Supervisor(s)</b>	M.Sc. Stefan Weiherer;  Dipl.-Ing. (Univ.) Johannes Auer		



<b>Ref.: R-IV</b>	<b>Title</b>	Life Cycle Assessment of Vertical Mills for Siemens Environmental Product Management		
<b>Author</b>	Paulina Casas Muñoz; Larisa Xanthopoulou	<b>Date</b>	July 2014	
<b>Abstract</b>				
<p>Sustainable development has been growing among companies, as they become more aware of the environmental and economic benefits it brings. This means that new innovative ways have to be generated for their production processes and product design, to create more value and be profitable. Tools such as Life Cycle Assessment (LCA) and Life Cycle Costing (LCC) can support the integration of environmental improvements and economic benefits. Siemens has implemented environmental performance assessment of products, as part of their strategy. They have, in corporation with Technical University of Denmark (DTU), developed a decision-support tool, the Eco-Care Matrix (ECM), which is tool for identification of both environmentally and economically beneficial solutions. Among Siemens product portfolio, they are supplier of drive systems for vertical mills, used mainly in the cement industry. Vertical mills are stones grinding machines with a weight of more than thousand tonnes and they are operated almost 24/7 for up to 20 years. During their use they consume a large amount of energy, contributing to a number of environmental impacts.</p> <p>This project represents an LCA study performed on a vertical mills operating with three alternative drives produced by Siemens: KMPP drive of 6 MW, MultipleDrive of 6 MW and MultipleDrive of 12 MW. KMPP drive is conventional technology that is compared with newly developed MultipleDrive, which can provide 5 % of energy saving due to the variable speed drive. Additionally, LCC analysis has been applied for the same functional unit as LCA, to find the sustainable solution. The functional unit, which is a reference unit for products quantified performance, is defined in this study as a total production of KMPP operating vertical mill during its life time of 20 years – “Grinding of 25185000 tonnes of clinker from thickness of 30mm to very fine under normal operating conditions”. The results of LCC and LCA have been combined and presented though the ECM tool, where the sustainable - “Green solution” has been identified. Recommendations to the company have been generated.</p> <p>It is seen that the use stage is dominant for about 90% of the total impacts in LCA and the total costs in LCC. The MD 6 and 12 have a better environmental performance in all impact categories, where the environmental benefit comes</p>				

mainly from the 5% energy saving. The difference between the three options was approximately 4.5% for most of the LCA impact categories. Even though, it is relatively small difference, it is considered significant as it corresponds to more than 20 million kg of CO<sub>2</sub> saved over a life time. From the economic perspective, MD 12 is the preferable option, where benefits comes mainly from the different operation profiles and the 5% energy saving. The LCC comparative study between KMPP and MD 6 and 12, showed a reduction in the total life cycle costs of 3.5% and 5.6% respectively. Both MD 6 and 12 have been identified as “Green solutions” for the three ECM drawn, which are Global warming, Metal depletion and Human toxicity - categories defined as relevant. Sensitivity analysis showed that change of parameters connected to the use stage has high implication on the results, both in LCA and LCC. The study results are considered limited to the defined scenario and assumptions. It is suggested to improve the model with more precise data from the company and from the customer’s site for more robust results. The present work can be used by the company as template for performance of similar analysis on the customer’s specific cases, in cooperation with the client, using the complementary data provided by the customer.

<b>Institution</b>	Danske Technical University; Department of Management Engineering - Qualitative and Sustainability Assessment (QSA);
<b>Supervisor(s)</b>	Prof. Niki Bey;  Dipl.-Ing. (Univ.) Johannes Auer

<b>Ref.: R-V</b>	<b>Title</b>	Life cycle assessment of products for industrial communication	
<b>Author</b>	Jeanette Ullmann	<b>Date</b>	August 2014
<b>Abstract</b>			
<p>Goal of this case study was to quantify the potential environmental impacts of a CP 1542-5 communication module and evaluate their drivers. Results showed that the main drivers of environmental impacts in the manufacturing stage are the printed circuit boards and the integrated circuits, with low possibilities to influence positively, since these components are functionally essential. Especially the ICs, as application specific ICs (AISCs), are only integrated to the extended necessary, due to their price. Further the case study indicated the low relevance of the communication modules in automation system context, due to the low power consumption compared to e.g. drives.</p>			
<b>Institution</b>	Wilhelm Büchner University of applied science (FH), Darmstadt, Faculty of engineering		
<b>Supervisor(s)</b>	Prof. Dr.-Ing. Peter Wack;  Dipl.-Ing. (Univ.) Johannes Auer		

<b>Ref.: R-VI</b>	<b>Title</b>	Partial automation of Life Cycle Assessments in GaBi6	
<b>Author</b>	Günther Pröls	<b>Date</b>	February 2015
<b>Abstract</b>			
<p>Since life cycle assessment is a complex and resource intensive process, this project commissioned by Siemens AG aimed at developing and testing two approaches for simplification, especially concerning manufacturing and the end-of-life stages. Background is the broad product portfolio of the Siemens Industry sector, usually utilized in systems as drive and automation systems for discrete process industries and the high relevance of the use stage.</p> <p>The first approach is referred to as Black-Box-Model, and aims at developing a product family specific, parameterized model. Here the input of one (or more) device specific parameter, e.g. for asynchronous motors the product mass (related to the nominal power), will configure further settings in the model (life cycle inventory) to conduct the life cycle impact assessment. To define an appropriate parameter and to develop the corresponding model, a detailed analysis of the bill of material was conducted to evaluate correlation between the parameter and the products composition. After these correlations then were utilized by the means of mathematical functions related to the defined parameter in the LCA model in GABI. For the composition of the asynchronous motors product family, the product mass was found to be a good parameter for derived linear functions for the individual, relevant material groups (copper, steel, aluminium, etc.), indicated by a coefficient of determination <math>R^2 &gt; 0.98</math>. Associated manufacturing processes were also allocated then to the material groups by mass.</p> <p>The approach was then validated by comparing the results derived by the simplified models to results obtained from previously conducted detailed LCA case studies of the products. For instance the mean deviation in the category Global Warming Potential (GWP) of the manufacturing stage of 4 asynchronous motors was 5.07 %. This seems to be acceptable, especially when putting the manufacturing stage in context to the use stage, which dominates environmental impact to a large extent. Further resource savings were calculated to about 58 working hours compared to conducting individual case studies for 4 products. Resource savings will grow with the amount of products covered, so for instance a model for 8 motors results in saving of about 118 working hours.</p> <p>The second approach developed and tested was aiming in reducing efforts for</p>			

individual life cycle assessment throughout the Siemens Industry sector, by providing a harmonized approach with supporting templates. The approach was realized by providing a common file share (Microsoft SharePoint) a standardized Input-Output document (LCA report) to derive the life cycle inventory through specific matching tables. The matching tables include a translation of the material and component descriptions in the BoM, as exported from the Siemens PLM tool, to the corresponding GABI datasets. Foundation for the efficiency of this approach is the matching itself, which means that of a high degree of already matched components and material will save a lot of time, whereas in case of a low coverage savings are neglect able. But anyhow using all conducted cases as basis for a common matching will steadily improve the situation and a harmonized matching is also assured.

<b>Institution</b>	University of applied science (FH) Amberg-Weiden; Faculty of Mechanical Engineering and Environmental Engineering
<b>Supervisor(s)</b>	Prof. Dr. Burkhard Berninger; Dipl.-Ing. (Univ.) Johannes Auer

<b>Ref.: R-VII</b>	<b>Title</b>	Simplification of Life Cycle Assessment through Black Box Modelling		
<b>Author</b>	Cecilie Overgaard Fjordmand	<b>Date</b>	August 2016	
<b>Abstract</b>				
<p>The goal of this study was to see if Black Box Modelling can become a supplement to Life Cycle Assessment because it is a very complicated process, which Black Box Modelling could simplify. This was done by calculating 5 Life Cycle Assessment on Siemens soft starters. The material flows are created in excel and later included into GaBi which result in the 5 Life Cycle Assessments. From this comes 4 precise and 1 reasonable precise Life Cycle Assessments, which the Black Box Models are built upon. There is made several models, where the best one is verified with a deviation of only 3,9% in average. This leads to the conclusion that Black Box Modelling probably is precise enough to be used as a simplification method for Life Cycle Assessment. It is however advised that there is included at least 2 more soft starters to increase the precision of the model, and some more soft starters to verify the results. Another result of the study is that it is more precise to use the total normalised impact than building the Black Box Model upon the categorised impacts.</p>				
<b>Institution</b>	Danske Technical University; Department of Management Engineering - Qualitative and Sustainability Assessment (QSA);			
<b>Supervisor(s)</b>	Prof. Niki Bey; Dipl.-Ing. (Univ.) Johannes Auer			



# ANNEX B: COURSE REPORTS



CAPSTONE PROJECT REPORT: ANALYSIS  
OF THE EFFICIENCY OF THE ECODESIGN  
DIRECTIVE IN REGARD TO THE POLITICAL  
GOAL ON CLIMATE CHANGE

# **Capstone Project Report: Analysis of the efficiency of the Ecodesign directive in regards to the political goal on climate change**

CBS/KU/DTU course –

„Sustainability Challenges & Systems Thinking II: Specific Systems and capstone project“

Fall 2015

**Johannes Auer**

DTU MAN QSA

closed 19. November 2015

**Siemens AG**

PD EHS, Gleiwitzer Str. 555, 90475 Nürnberg, Germany

# Content

<b>Content</b> .....	<b>2</b>
<b>Figures</b> .....	<b>3</b>
<b>List of tables</b> .....	<b>3</b>
<b>Introduction</b> .....	<b>4</b>
1.1 Sustainability Challenges & Systems Thinking .....	4
1.1.1 Earth system & planetary boundaries.....	5
1.1.2 Business Interaction Systems: Governance, Innovation and Business Models ....	8
1.2 Capstone project background: Sustainability challenge in energy context .....	9
1.2.1 Motivation .....	9
1.2.2 Goal & Scope .....	10
<b>2 Theoretical background on the efficiency of policy measurements in regards to the political goals on sustainability</b> .....	<b>11</b>
2.1 Political target and policy background.....	11
2.1.1 EU 2020 climate and energy package .....	11
2.1.2 Ecodesign directive .....	12
2.2 Theoretical background on the efficiency of policy measurements in contemporary literature .....	14
2.2.1 Aspects of the efficiency of policy measurements in regards to the political goals on sustainability .....	14
2.2.2 Methodology approaches for accounting for the and supporting the target achievement.....	18
<b>3 Results, discussion and conclusions</b> .....	<b>21</b>
3.1 Results and discussion.....	21
3.1.1 Energy efficiency progress in EU 2020 target on climate and energy .....	21
3.1.2 ErP in context to research background on the efficiency of governance instruments .....	22
3.2 Conclusions and Recommendations.....	25
3.2.1 Governance instruments .....	25
3.2.2 Industry.....	26
<b>4 References</b> .....	<b>28</b>

## Figures

Figure 1: Graphical display of the idea behind and the teaching content of the CBS/KU/DTU course on “sustainability challenges and systems thinking” .....	5
Figure 2: Line plot of global mean land-ocean temperature index, 1880 to present, with the base period 1951-1980. The dotted black line is the annual mean and the solid red line is the five-year mean. The green bars show uncertainty estimates. (This is an update of Fig. 9a in [Hansen 2010]) [GISTEMP 2015].....	6
Figure 3: Fossil fuel related carbon dioxide (CO <sub>2</sub> ) emissions over the 20th century. Image source: EPA.....	7
Figure 4: The IPAT equation in sustainability (environmental) context. ....	7
Figure 5: Visualization of "leapfrog development" countering the Environmental Kuznets Curve (EKC). ....	9
Figure 6: Overview of the process structure of the implementation of the ecodesign directive [EUP 2015c].....	13
Figure 7: The three pillars of sustainability [Zaman, Goschin 2010].....	15

## List of tables

Table 1: The six aspects of the “Deliberative System” as framed by [Dryzek, Stevenson 2011].....	17
--	----

# Introduction

## 1.1 Sustainability Challenges & Systems Thinking

The motivation to offer a multi- to inter disciplinary course on sustainability challenges and systems thinking, the Copenhagen Business School (CBS), the Copenhagen University (KU) and the Danish Technical University (DTU) were:

- Business, government and civil society are facing complex sustainability challenges that they cannot solve alone.
- These challenges have technological, engineering, scientific, financial, managerial, political, social and environmental components.
- Tackling them often requires a holistic perspective, partnerships between the private and public sectors as multi-stakeholder initiatives.
- Need to develop a common language and understanding with specialists in other fields bridging the gaps between science, technology and business solutions to sustainability

Based on the key learnings of the teaching Figure 1 was derived to visualize the necessary interaction of involved disciplines and their circular relationship. Natural or social sciences provide the scientific background for governance institutions like initiatives or policy makers to develop a certain framework. Businesses respond to the set framework with the engineering of new solutions or development of technology as well as new business models.

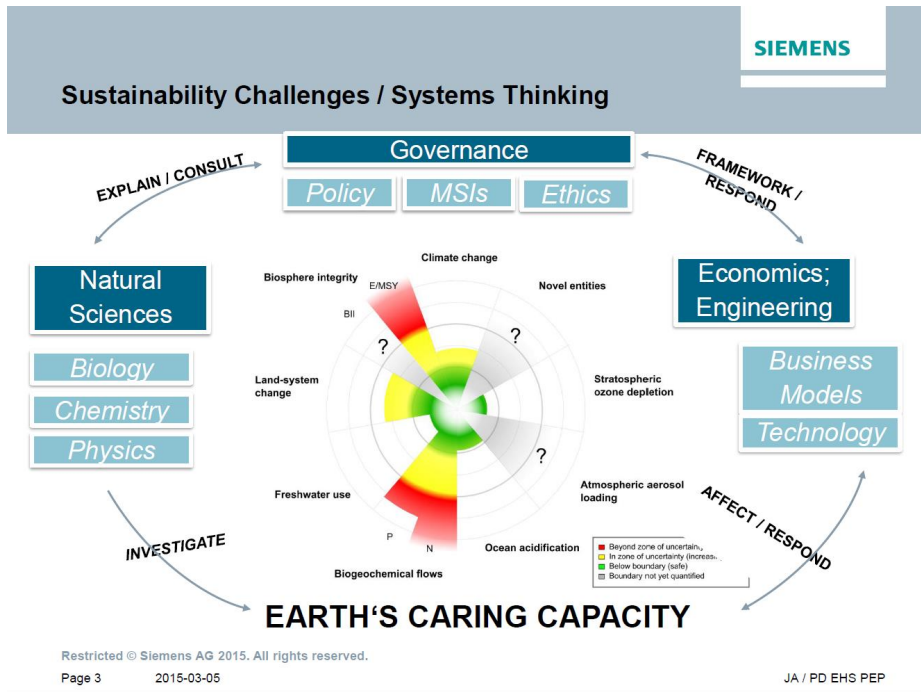

Figure 1: Graphical display of the idea behind and the teaching content of the CBS/KU/DTU course on “sustainability challenges and systems thinking”.

Teaching was subdivided into 3 pillars:

- Earth System & Planetary Boundaries,
- Business Interaction Systems,
- Production Systems & Systems Thinking,

Which key points in context to the study are briefly summarized in the following sub-chapters.

### 1.1.1 Earth system & planetary boundaries

Mankind’s influence on the system earth is undeniable; climate change by global warming through certain emissions for instance has finally been accepted as being caused by industrial activities [Roach 2004], whereas debates on that fact have been going for ages, starting from the 70s until – in a political context – today. [Oreskes 2004].

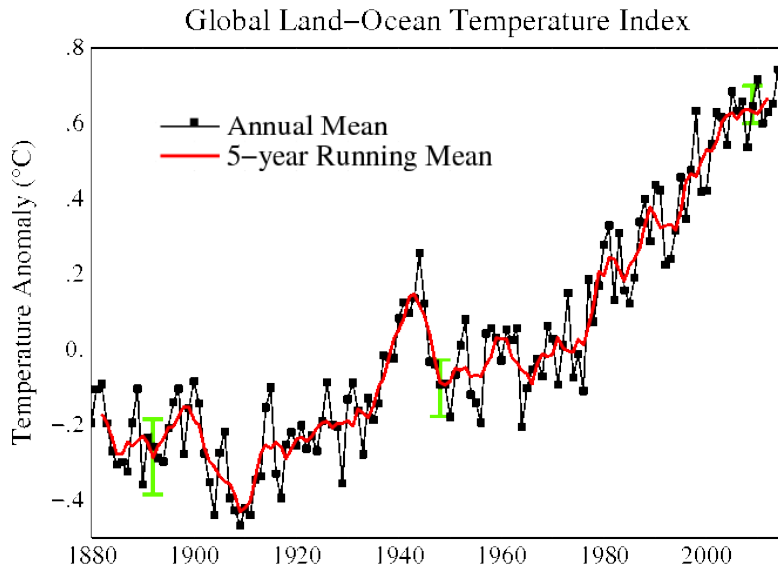

Figure 2 shows the global land-ocean temperature index from 1880 to present and Figure 3 the fossil fuel related carbon dioxide emissions. [GISTEMP 2015].

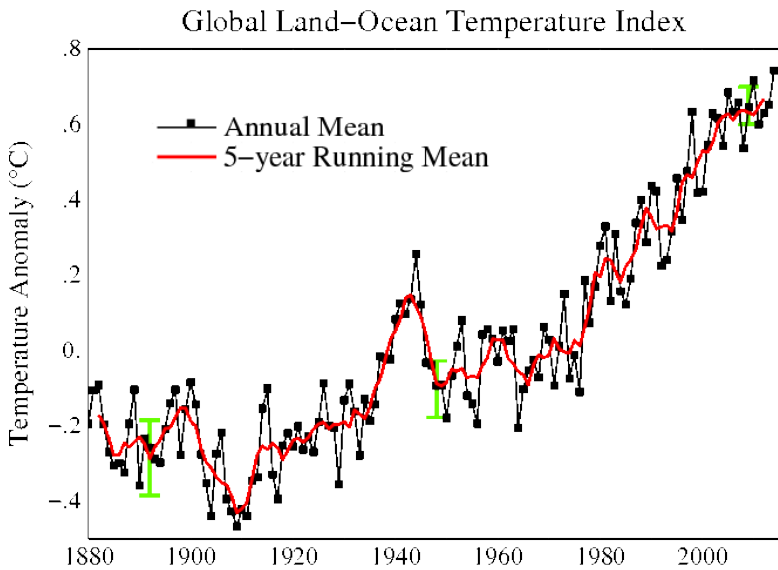

Figure 2: Line plot of global mean land-ocean temperature index, 1880 to present, with the base period 1951-1980. The dotted black line is the annual mean and the solid red line is the five-year mean. The green bars show uncertainty estimates. (This is an update of Fig. 9a in [Hansen 2010]) [GISTEMP 2015].

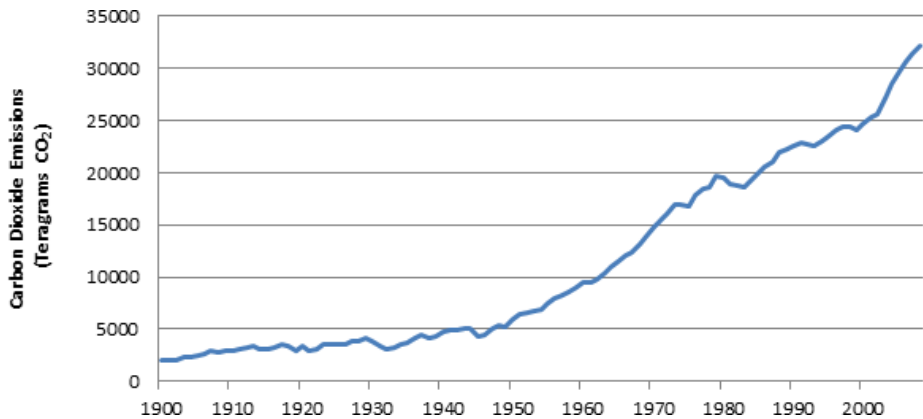

Figure 3: Fossil fuel related carbon dioxide (CO<sub>2</sub>) emissions over the 20th century. Image source: EPA.

Finally in 2015 at the Paris climate conference (COP21) in December 2015, 195 countries adopted the first-ever universal, legally binding global climate deal. The agreement sets out a global action plan to put the world on track to avoid dangerous climate change by limiting global warming to well below 2°C. The agreement is due to enter into force in 2020.

The Ehrlich equation or simply IPAT equation can be used to quantify the impact of humanity on the environment. The IPAT equation as defined by [Ehrlich 1971] as: Impact = Population \* Affluence \* Technological efficiency, is shown according to further development by Graedel and Allenby [Clini et al 2010] in Figure 4.

### The IPAT equation



$$I = P \cdot A \cdot T = Pop \cdot \frac{GDP}{person} \cdot \frac{I}{GDP}$$

(Graedel and Allenby, 1995)

- $I$  is the **environmental Impact**
- $Pop$  is the **global Population**
- $\frac{GDP}{person}$  is the **Affluence**, the material standard of living ("needs")
- $\frac{I}{GDP}$  is the **Technology factor** - the inverse of the "eco-efficiency" (being: "created value per impact")

Figure 4: The IPAT equation in sustainability (environmental) context.



Thinking this through, technology or the technology factors has to play a major role for solving current and future sustainability challenges. Population is steadily on the rise and Affluence assumed to do so likewise or at least to stay on the current level, therefore the only factor enabling humans to keep or better reduce their impact on the environment is technology.

### **1.1.2 Business Interaction Systems: Governance, Innovation and Business Models**

As laid down in the previous chapter the technosphere plays a major role in providing solution to sustainability challenges. Business is framed by governance through policies or initiatives, driven by a political will through governments or non-governmental organizations. For these issues, culture and education of people on sustainability aspects is an important factor. For business challenges as well as opportunities arise in that context, as indicated, a.o., in [Hall et al 2003]. A (globally) harmonized and – more or less – predictable business framework is important for sustainable success, whereas for that, and additionally for target achievement, the orchestration of different governance instruments is a core requirement as shown for two sectors by [Lister et al 2015] and [Henriksen, Ponte 2015]. The orchestration of different governance instruments, means the effective interaction of direct (e.g. energy efficiency levels, substance restrictions) and indirect (taxation, emission trading and levels) regulations, as well as standards or certification schemes, self-regulation (associations) or corporate ethics (corporate social responsibility).

Business response can cope with new, enhanced regulations or initiatives by innovations in technology or new business models. Technology innovations are countless, like for instance in automation (e.g. energy management capabilities) and drive technologies (e.g. energy efficiency, motion control), power generation and distribution and mobility (e.g. emission levels, electric drives) and a major opportunity in regards to dealing with sustainability challenges and the correlation of emission per capita over time as visualized by the Environmental Kuznets Curve [Dinda 2004] in Figure 5, is the so-called technology leapfrog development, like for instance explained for the energy sector by [Goldemberg 1998].

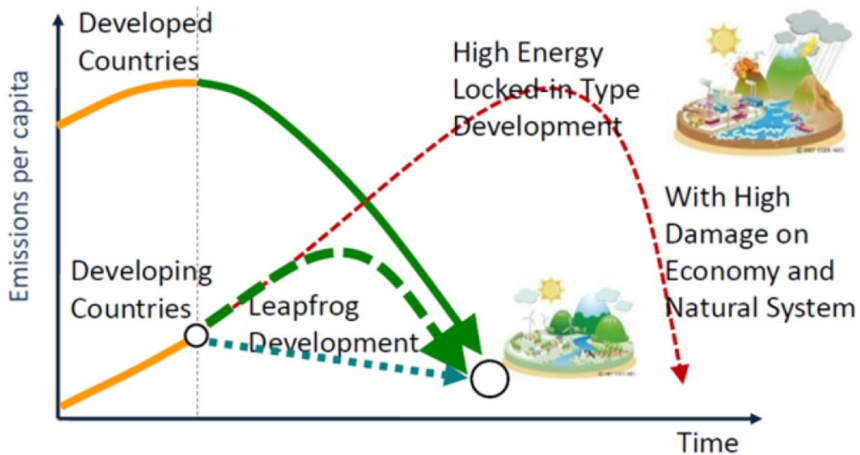

Figure 5: Visualization of "leapfrog development" countering the Environmental Kuznets Curve (EKC).

Concerning business models as most prominent examples in sustainability context, the following can be mentioned:

- Car-sharing as example of “servizing”;
- Leasing concepts on production systems in the chemical sector;
- Contracting in financing energy efficiency measures.

## 1.2 Capstone project background: Sustainability challenge in energy context

### 1.2.1 Motivation

One major sustainability challenge for the 21<sup>st</sup> century are the climate relevant emissions associated with energy consumption, especially through the power generation through fossil energy carriers like oil and its related distillates, coal and natural gas. The contribution of these emissions like Carbondioxid, Methan and Sulphurhexaflourid to the increase of earth’s middle temperature and the relevance of that issue to the eco systems is scientifically agreed [IPCC 2007] and recent political developments aim at mitigating related risks for future mankind [COP21].

The political European Union since years has been a front runner in approaching this challenge by different political instruments and their combination. One key instrument in the orchestra is the so called Ecodesign directive, the “Energy related Products” (ErP)

directive [2009/125/EC], valid since 2009, in succession to the “Energy using Products” (EuP) directive [2005/32/EC] from 2006.

Since the orchestration of governance instruments is a key issue to the efficiency of political targets, the case study shall analyse the EU 2020 target for climate and energy and the Ecodesign directive corresponding to the key aspects derived from the context to relevant literature provided in the syllabus of the course, providing some insight to an appropriate set up for industry on how to deal with policies in European context.

The idea behind this case study was to gain further insight on the appropriate setup or strategy for industry in context to accepted political targets and corresponding governance instruments. The ErP is a framework directive relevant for industry in a broad spectrum of sectors and was therefore chosen a good suitable governmental instrument for the evaluation of improvement potentials on the consideration of sustainability aspects in the innovation management process of these companies.

### **1.2.2 Goal & Scope**

Target of the study is to analyse one of the lead framework directives of the European Union in regards to its effectiveness in tackling the sustainability challenge of energy consumption related, climate relevant emissions.

The analysis should be considering the efficiency of the directive and EU targets for climate and energy in regards to the research background on the efficiency of policy measurements. Conclusions on the research topic shall further include recommendations for policy makers and industry concerning an appropriate approach.

## **2 Theoretical background on the efficiency of policy measurements in regards to the political goals on sustainability**

### **2.1 Political target and policy background**

#### **2.1.1 EU 2020 climate and energy package**

##### **2.1.1.1 Introduction**

Global warming has to be limited to below 2°C compared to the average temperature in pre-industrial times to prevent the most severe impacts of climate change and possibly catastrophic changes in the global environment. This was agreed by almost all countries worldwide in 1992 under the United Nations Framework Convention on Climate Change (UNFCCC) and just recently tightened through [COP21].

To achieve this, the world must stop the growth in greenhouse gas emissions by 2020 and reduce them by 60% by 2050 compared with 2010. [COM 2010]

##### **2.1.1.2 Quantitative targets**

The following targets were set for the European Union within the EU 2020 strategy:

- 20% cut in greenhouse gas emissions compared with 1990
- 20% of total energy consumption from renewable energy
- 20% increase in energy efficiency.

The 2020 climate and energy package is a set of binding legislation to ensure the EU meets its climate and energy targets for the year 2020.

The targets were set by EU leaders in 2007 and enacted in legislation in 2009. They are also headline targets of the Europe 2020 strategy for smart, sustainable and inclusive growth [COM 2010] [EC 2020].

##### **2.1.1.3 Measures and policies to improve energy efficiency**

The EU has adopted a number of measures to improve energy efficiency in Europe. They include:

- an annual reduction of 1.5% in national energy sales
- EU countries making energy efficient renovations to at least 3% of buildings owned and occupied by central governments per year

- mandatory energy efficiency certificates accompanying the sale and rental of buildings
- minimum energy efficiency standards and labelling for a variety of products such as boilers, household appliances, lighting and televisions (EcoDesign)
- the preparation of National Energy Efficiency Action Plans every three years by EU countries
- large companies conducting energy audits at least every four years

Accompanying these measures as set targets the following legislative acts were issued:

- Energy Efficiency Directive (2012/27/EU)
- Energy Performance of Buildings Directive (2010/31/EU)
- Energy Labelling Directive (2010/30/ EU)
- Ecodesign Directive (2009/125/EC)

## **2.1.2 Ecodesign directive**

### **2.1.2.1 Policy background**

To achieve the set targets accompanying legislative acts, like for instance the “ecodesign directive”, or more specifically the "Directive 2009/125/EC of the European Parliament and of the Council of 21 October 2009 establishing a framework for the setting of ecodesign requirements for energy-related products”, were issued. The ecodesign directive aims at improving the environmental characteristics of energy-related products by establishing generic and specific ecodesign requirements. The directive entered into force on 20 November 2009 and replaces the previous Ecodesign Directive 2005/32/EC.

The amendment of Directive in 2009 concerns its scope, which has been extended from "energy-using" (EuP) to so-called "energy-related" products (ErP).

The directive is an important instrument of environmental product policy. As a major share of the environmental impacts of products are predetermined during the design and construction phase, it is important to consider their impacts over the entire life cycle already in the production [EUP 2015a].

### **2.1.2.2 Implementation process**

To substantiate the requirements for the environmental performance of selected products and product groups, the directive allows for two fundamentally different regulatory alternatives: a regulation (implementing measures) by the European Commission (EC) or self-regulation initiatives by the relevant industries e.g. through their trade associations.

Based on Article 16 of the directive, the EC, after seeking the opinion of the Consultation Forum and in coordination with the Regulatory Committee, determines every three years the product groups to be dealt with in a working plan based on supporting studies. The first Working Plan was defined for the period from 2009 to 2011 [COM 2008]. The second Working Plan applies for the period from 2012 to 2014 [SWD 2012]. From January 2014 a twelve month project was conducted to support the European Commission to develop the next work plan [BIO 2014]. Within this working plan products or product groups are collected in so-called lots. These product lots are then analysed with a predefined methodology, the MEEuP or MEErP developed by a consultant (VHK), to evaluate the most relevant environmental impacts of the products [MEERP 2015]. Based on this preparatory studies requirements for the environmental performance of the selected product groups are defined.

The participation of stakeholders (industry and its associations, SMEs, trade unions, retailers, importers, organisations for consumer and environmental protection) in the implementation process is ensured through the so-called Consultation Forum. It serves as forum to discuss drafts of implementing measures and impact assessments proposed by the Commission. The whole process is visualized in Figure 6.

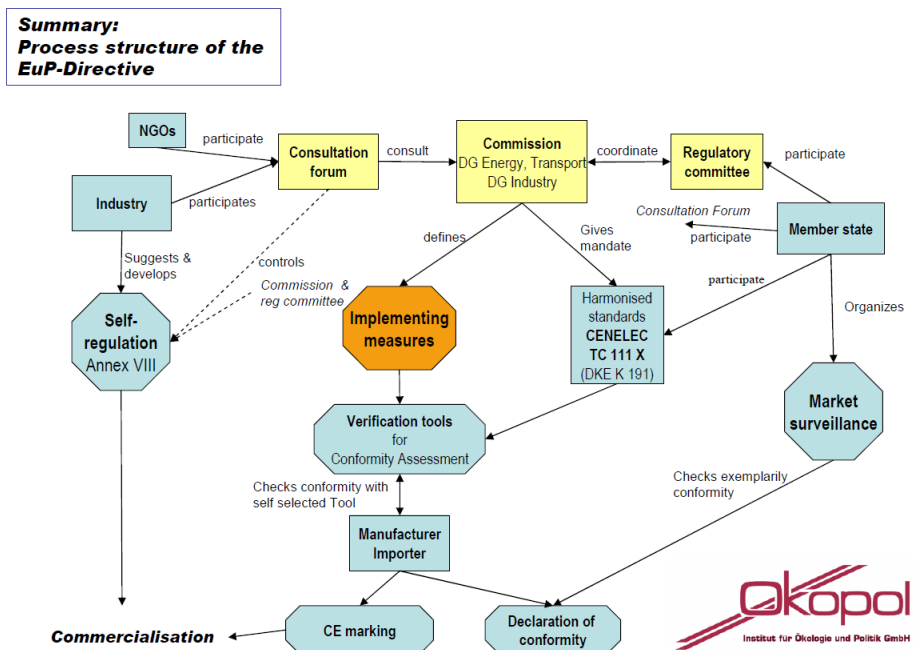

Figure 6: Overview of the process structure of the implementation of the ecodesign directive [EUP 2015c]

Following the consultation phase an impact assessment is completed for each implementing measure and the Commission discusses the measure internally (Interservice Consultation, ISC) and notifies it to the WTO. Finally, the draft regulation is presented for vote to an assembly of EU Member States representatives, known as the Regulatory Committee. The European Parliament then has the opportunity to intervene before an implementing measure enters into force.

The manufacturer or importer, respectively, is responsible to ensure the conformity of a product with the requirements. The national market surveillance authorities of the member states check the compliance of the products through random tests.

### 2.1.2.3 Product example: Motors

Within the first work plan, motors were addressed as lot 11 and resulting from the conducted preparatory study was a so called implementing measure, initially issued in 2009, regulating the efficiency levels of motors and since 2014 in context (power) drive systems to be put on the market of EEA [EU 2014].

Electric motors use almost 50% of the electricity in Europe. They are in machines such as elevators, cranes and cooling systems. With a more efficient motor, an average of €700 can be saved over the lifetime of the product. More efficient motors could save Europe around 135 TWh of electricity by 2020 – equivalent to the annual electricity consumption of Sweden. This means over 60 million tonnes of CO<sub>2</sub> emissions will be avoided. Some motors designed for specific conditions, for example those that operate immersed in a liquid such as in a sewage system, are excluded from these requirements [EC 2015a].

The product group electrical motors are chosen as a practical example for evaluating the efficiency of the directive within this capstone project.

## **2.2 Theoretical background on the efficiency of policy measurements in contemporary literature**

### **2.2.1 Aspects of the efficiency of policy measurements in regards to the political goals on sustainability**

Research background on the efficiency of policy measures in regards to sustainability goal by governmental institutions as provided through literature references in the course compendium is summarized in the following key issues.

#### 2.2.1.1 Key Issue: Terminology and the influence of uncertainty

Taking in account the three pillars of sustainability as displayed in Figure 7 from [Zaman, Goschin 2010], [Dovers, Handmer 1992] states that:

*The problem with sustainable development has been often enough stated. As currently defined, it is so broad and generically applicable that its inherent vagueness renders it inoperative, and open to conflicting interpretations. Indeed, the notion has become a vector for ideology.*

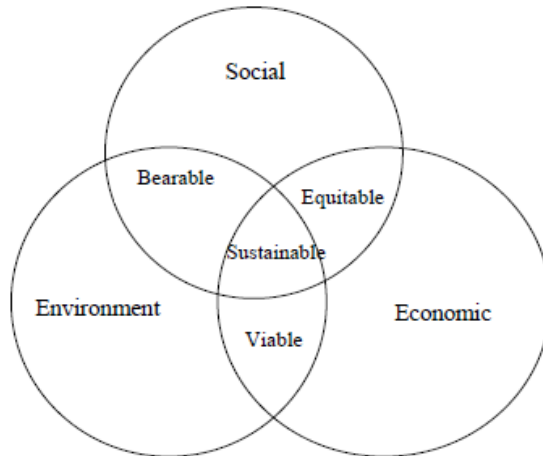

**Figure 1.** Scheme of sustainable development at the confluence of the constituent parts

**Source:** UCN 2006, *The Future of Sustainability. Rethinking Environment and Development in the Twenty-First Century*, Report of the IUCN Renowned Thinkers Meeting, 29-31 January 2006, [http://cmsdata.iucn.org/downloads/iucn\\_future\\_of\\_sustainability.pdf](http://cmsdata.iucn.org/downloads/iucn_future_of_sustainability.pdf)

Figure 7: The three pillars of sustainability [Zaman, Goschin 2010]

Based on the lack of an agreement throughout the involved parties and stakeholders, as well as the issue that contributors to phenomena subsumed under the term sustainability are numerous, complex and steadily moving, the understanding of sustainability highly differs, which in the end leads to a high level of uncertainty. These uncertainties then hinder the efficient definition of solutions. Finally the authors come to the conclusion that that the challenge of establishing a sustainable pattern of development can be characterized as a problem of managing change in complex, poorly understood systems. Solutions need to be elaborated at least multi-, better inter- or even transdisciplinary, each approach with its own challenges, summarized in a *sustainability science* [Zaman, Goschin 2010].

### 2.2.1.2 Key Issue: Systems Thinking

[Dovers, Handmer 1992] addresses the key point of systems thinking on basis of systems theory. There's a strong interconnection between systems, like for instance biological and physical systems, as well as the ecosystem and human systems. They are framing sustainability in a global context: not exporting problems, challenges into other



countries, but tend to them in a systems perspective and the fact that *sectorial or single issue approaches are clearly inadequate*. Besides *hard systems*, like for instance bio-physical systems, also *soft systems*, like cultural aspects or ethics, have to be taken into account. Additionally (backed up by [Zaman, Goschin 2010]) high importance has to be paid to multi-, inter- and transdisciplinary and crossfunctional approach to risk management in terms of the resilience of systems to certain effects. Resilience in systems theory is basically the sustainability of the systems. One key issue in this context is the consideration of rebound effects (Jevons's paradox, 1865) and the avoidance of sub-optimizations, like for instance of parts of the system, that then might affect the whole system negatively.

### 2.2.1.3 Key Issue: Climate Justice and Governance

[Bulkeley et al 2012] stated:

*Ever since climate change came to be a matter of political concern, questions of justice have been at the forefront of academic and policy debates in the international arena. Curiously, as attention has shifted to other sites and scales of climate change politics matters of justice have tended to be neglected.*

In that context, considering terminology and systems thinking issues, another key challenge in coping with sustainability issues is the a.m. debate. Generally as pointed out already earlier, negatively rated effects on the eco systems emerging from human activity have grown to such complexity that they have to be dealt with globally in a systems context.

The debate on climate justice is associated with markets or countries, as well as industries causing today's effects on the climate, now trying to mitigate them and urging the so called emerging markets, no fully developed countries to do alike. But these emerging markets do claim their share on environmental resources, like for instance cheap energy, for the further development for their industries and their prosperity. In other words there are different priorities in nation's agendas that hinder agreements needed for the mitigation.

Another aspect on the efficiency on policy measures or more generally governance then is to consider the relationship between the form of government and political processes and environmental or sustainability performance. [Dryzek, Stevenson 2011] have learned from the investigation of environmental performance of different states (sponsored by the World Economic Forum) that the top performers are consensual democracies. Corporatism, as a subform of consensus democracy, is a key issue here, which requires joint policy making by representatives of business and labour associations and the government executives. In the end – through e.g. balancing the ecological, societal

and economical values – this leads to a higher acceptance and understanding on the targets associated with the policy and – through openly debating on the policy – it also tackles cultural aspects, thus enabling better performance.

On a global scale or at least a higher level regional conglomerate, not a single state like for instance the EU or the USA, the following four principles are the most important aspects to efficiency or performance:

- 1) Integration of multiple perspectives on complex issues.
- 2) Prioritisation of public goods and generalizable interests over sectional interests.
- 3) Facilitation of positive sum discourses such as ecological modernization.
- 4) Co-existence of moments of consensus and contestation.

Based on this, [Dryzek, Stevenson 2011] framed “The Deliberative System” based on the initial introduction by [Mansbridge 1999] in the sustainability context, which core aspects are summarized in Table 1.

Table 1: The six aspects of the “Deliberative System” as framed by [Dryzek, Stevenson 2011].

No.	System Aspect	Explanation
1	Public space	In public space a diversity of viewpoints and discourses can interact, ideally without legal restriction. Discourses might be engaged by activists, social movements, journalists, bloggers, or ordinary citizens.  Spaces might exist or be created in connection with, for example, physical places (classrooms, bars, and cafés), virtual locations (internet forums), the media, social movements, public hearings, and designed citizen forums.
2	Empowered Space	Empowered space is where authoritative collective decisions get produced, and can feature, for example, legislatures, constitutional courts, corporatist councils, empowered stakeholder dialogues, international negotiations, governance networks, or international organizations.
3	Transmission	Public space can influence empowered space through for example political campaigns, the argument and rhetoric of political activists, and cultural change initiated by social movements that eventually changes the

		outlooks of those in empowered space.
4	Accountability	Democratic legitimacy requires that empowered space be held accountable to public space. The most common means within democratic states is through elections, though these are not necessarily very deliberative affairs. But accountability means, quite literally, having to give an account; it does not have to involve the possibility of sanction through, for example, removal from office.
5	Meta-Deliberation	Meta-deliberation is the reflexive capacity of those in the deliberative system to contemplate the way that system is itself organised, and if necessary change its structure. As Thompson (2008: 15) puts it, not all practises and arrangements need to be deliberative all the time, but they do need to be justifiable in deliberative terms.
6	Decisiveness	The deliberative system should be consequential when it comes to the content of collective outcomes. That is, deliberation should not be a sideshow that obscures where key decisions actually get made. Democratic deliberation should be consequential as well as authentic and inclusive.

## 2.2.2 Methodology approaches for accounting for the and supporting the target achievement

[Bjørn, Hauschild 2012] well described the 2 major, opposed philosophies, one with a relative approach and the other with an absolute approach which are summarized in the following:

### 2.2.2.1 Eco-efficiency; Relative Sustainability

The concept of eco-efficiency focuses the sustainable development on the reduction of negative impacts in relation to the fulfilment of a certain, defined function. The life cycle assessment (LCA) methodology used to quantify environmental impacts of products, services and systems, as standardized in the ISO 14040ff series, and its spin-offs like social life cycle assessment, carbon or water footprinting provides the framework to measure and then compare various options and scenarios, e.g. displayed through eco-labels. The ILCD handbook [ILCD 2010] gives a good picture of the methodology, its

constraints and complexity due to the possibilities of application. The basic principle of LCA is to summarize and balance all inputs (materials, energy) and outputs (emissions waste) used within the life cycle of the object under study. Associated elementary flows are then grouped and link to potential environmental impacts in certain categories. In the end these potential impacts are expressed in terms of a quantitative indicator for these categories, like for instance kg CO<sub>2</sub>-equivalents.

Today LCA or eco-efficiency is – more or less – established in this context, also due to the fact that striving for the efficiency is well established on economic and engineering agendas. Key challenge currently is the smart application of the methodology (eco design or footprints; accuracy vs simplification and focus on key aspects; cost vs benefit) and the uncertainties in the underlying data landscape as well as the prediction of the effects of certain potential impacts, especially in the long term. Another issue is that the currently scientifically established midpoint categories and scores resulting from case studies are not very meaningful. For a reasonable interpretation normalization and weighting is needed, but necessary normalization references are still under development. In terms of tackling sustainability challenges it has been shown that the eco-efficiency approach failed to improve in absolute numbers [set, for instance

#### 2.2.2.2 Cradle-2-Cradle(C2C); Absolute Sustainability

*C2C's approach to sustainability is to “*

*maximise the benefit to ecological systems” rather than the approach of eco-efficiency of reducing the damage.*

According to [McDonough, Braungart 2002], the concept is based on three key principles:

- Waste equals food: The first key principle calls for the elimination of the very concept of waste and encourages inspiration by nature's seemingly perfect nutrient cycles. The focus is to design systems with emissions that other processes can take up as nutrients instead of trying to reduce the amount of waste as advocated by eco-efficiency.
- Use current solar income: dictates that the energy required to fuel a continuous-loop C2C society must all originate from “current solar income,” defined as photovoltaic, geothermal, wind, hydro, and biomass.
- Celebrate diversity: Avoiding one-size-fits-all solutions is the main point of this last key principle. Instead, products and systems should be designed with respect for local cultures, economies, and environments

Generally it can be stated that the C2C is visionary, not very well established in industry and governmental institutions and therefore still needs further research. One drawback evaluated by [Bjørn, Hauschild 2012] today's technology (like for in-

stance recycling options or waste logistics; energy supply) and current applicable regulations don't fully suit or support the approach.

### 2.2.2.3 Absolute vs. Relative Sustainability

Both approaches do have their relevance and justification, according to [Bjørn, Hauschild 2012] both could be enhanced supplementary by the integration of certain aspects from one to another. One possible route could be the elaboration of normalization references based on absolute value, like the ecosystems carrying capacity, that can be applied in LCA. Benefit would be to overcome the drawback of eco-efficiency by putting its results into a broader, absolute context, making them more accessible to the public and more useable in terms of governance aspects, like policy making or accounting for target achievement.

## 3 Results, discussion and conclusions

### 3.1 Results and discussion

#### 3.1.1 Energy efficiency progress in EU 2020 target on climate and energy

According to the conducted impact assessment on the EAP in 2010, communicated to the public in [SEC 2011]:

*...the EU is not on track to fully realize this cost-effective energy savings. Whilst, the latest business-as-usual scenario shows a break in the trend towards ever increasing energy demand, the reduction in the consumption will be only about 9% in 2020. Therefore, if the EU does not double the efforts, it will not reach its 20% target and will not realize all the associated benefits for the economy, society and environment.*

At that point the Commission responded by developing a new and comprehensive Energy Efficiency Plan in 2011 (EEP). The Energy Efficiency Directive (2012/27/EU) entered into force in December 2012. Under it, the Member States are required to establish indicative national energy efficiency targets for 2020, based on either primary or final energy consumption.

Then According to the Energy Efficiency Communication of July 2014, the EU is now expected to achieve energy savings of 18%-19% by 2020 – missing the 20% target by only 1%-2%. However, if EU countries implement all of the existing legislation on energy efficiency, the 20% target can be reached without additional measures [SWD 2014].

In regards to that evaluation of the target achievement and the corresponding impact assessment reports, the following key issues for coping with the sustainability challenges of energy consumption were identified:

- **Market failures:**
  - Energy market prices prices do not do not reflect all costs to society in terms of pollution, greenhouse gas emission, resources' depletion, and geopolitical dependency. Therefore investments in energy efficiency have long payback times and decision maker in that context may be partially detached from the price signals (user, seller, assembler, manufacturer,...);
  - Initial costs are a considerable barrier as judgements on the profitability of investment are done on short pay-back times and improvements that

fail these criteria are not made even if they would bring benefits to the consumers but also society in the longer term. Proper financing instruments that take fully into account all financial benefits from energy efficiency gains are not developed or supported (accompanying policies, research projects or financing programs). Additionally current Investment practices don't support these investments because companies assets will increase.

- **Legislative failures:**

- The lack of a comprehensive policy framework including regulatory and support instruments, and a poor enforcement is clearly a major problem in some countries and therefore on European level. Correlations between the individual directives aren't considered appropriately, as well as there's no direct link to the targets. Too frequent changes in the legal framework or the political agenda make the investment climate risky and business becomes more reactive. Even though debate is a cornerstone to effective governance, The European set-up currently is at risk of too much of a debate.

- **Other barriers:**

- The rebound effect is another major challenge to energy savings. It implies that in spite of certain improvements of the efficiency of the individual products (e.g. appliances, cars and buildings), overall energy consumption linked to their use increases due to their increased volume, number or usage. The rebound effect itself is difficult to address at EU level because it relates to increased living standards, freedom of choice and consumer behaviour, for some member states a major reason to join, which they now see in threat.

### **3.1.2 ErP in context to research background on the efficiency of governance instruments**

In this chapter the Ecodesign directive as a policy will be analysed according to the identified key issues of the efficiency of governance instruments, based on the background as described in Chapter 2.

Looking at the Ecodesign or ErP directive and the underlying implementation process, the following statements in terms of key elements can be made in context to the theoretical background (clause 2.2) on governance instruments:

- 1) **It's a framework directive:** Framework directive in that context means that the directive itself just regulates the general approach, the basic principles of the policy (for all products in the scope), whereas concrete measurements are defined individually (on product group level). This avoids possible trade-offs due

to the complexity of “one-size-fits-all” solutions and therefore enables the policy makers to define effective requirements corresponding to the specialities of the product groups. On the downside of that, it can be stated that the system (thinking) aspect or rather the application context still isn’t reflected in the process or the policy itself appropriately. For instance when providing Computers, one has to deal with various individual implementing measures, like for instance concerning the efficiency of the power supply, integrated fans and standby-losses. Analogically this discussion came up when the implementing measure for electric motors was issued, but didn’t reflect the requirements of an application specific system design.

- 2) **The research based approach:** Through using private consultants as well a public institutions for the continuous development of the directive, the associated regulations and the underlying, assures an up-to-date approach based on most recent research results and established common sense. The reports available then provide insights to the motivational background of the policy as governance instrument to all stakeholders, which influence the acceptance of instrument positively.
- 3) **Stakeholder engagement:** Stakeholder engagement is assured within the implementation process of the directive, at least through the consultation forum and the regulatory committee as shown in Figure 6. Further stakeholders can comment and influence on the working plans, as well as the MEErP methodology, and they are involved in the preparatory studies. Therefore a broad debate is assure with, again, positive influence on the acceptance of final requirements.
- 4) **Implementing Measures vs. Self-regulation; Standardization:** On a positive note, the ErP leaves industry the option of a self-regulation in regards to energy efficiency. In terms of relying on various governance instruments, the ErP actively makes use the established standardization process for defining the technical background of the regulated aspect. This enables industry or the involved parties to seek global harmonization of these aspects. For instance in the electric motors industry, the determination of the motors’ efficiency, the efficiency classes and measurement tolerance is defined in an global applicable IEC standard, whereas the implementing measure in the EU only reflects the minimum efficiency needed for conformity when being put on the market. On the second hand this then stimulates a global debate on this issues via the standardization organizations and therefore again improves acceptance and drives understanding of this measurements, as well as knowledge dissemination.

These 4 key elements of the directive are now mirrored against the evaluated key issues in regards of efficiency of governance instruments:



- **Terminology and uncertainty:** Looking at the ErP as framework directive, it can easily be stated that not all pillars of sustainability are covered, but energy or rather resources are addressed appropriately which the target of increasing efficiency of utilization. This is effecting the environment as well as economy positively through reduced environmental impacts, e.g. GHG emissions, and cost reduction over the lifetime. Social aspects don't play a major role in context to the target of the directive, which is embedded in the overarching EU 2020 strategy (which includes social aspects) and the corresponding EEAP of the European Commission. Terminology also isn't an issue in the European context, also through the integration in the European strategy. Terminology can be stressed globally because Ecodesign often is related to "more" than "just" energy-efficiency. The recast in 2010 and the further work on the underlying methodology (MEEuP to MEErP) for the preparatory studies for the elaboration of implementing measures for product group in the scope, took that into account, stressing the issue of resource utilization further. From the current perspective Uncertainties seem to be manageable and addressed properly through the continuous, regular review process on all parts of the directive and the accompanying reports, like the impact assessment report 2011. In regards to involved disciplines, rating is rather good, since the work on the individual elements of the directive requires always at least engineering, economics and environmental experts for fulfilling the tasks described, like for instance for the preparatory studies for elaborating implementing measures.
- **Systems Thinking:** In terms of systems thinking, the results are to be rated differently. Whereas for the elaborating of the working plans, a pragmatic approach to addressing the most relevant energy consuming sectors and product groups is used. The methodology, elaborated for the underlying the preparatory studies, has its weaknesses. First up, even though being quantitative it's not very consistent with the ILCD recommendations for LCA and even MEErP claims neither ISO 14040/44 conformity nor ILCD compliance, it's elaborated for purposes LCA was developed for. Therefore known constraints of a similar methodology used on a similar purpose should be kept in mind during interpretation of results of analysis with MEErP. Additionally planetary boundaries or the topic of absolute sustainability (here in context to the set targets of the overarching EU 2020 strategy) is not considered. Another weakness in regards to systems thinking, overregulation in certain product groups, was already mentioned in the previously describe key elements of the directive. Additionally another example in that context can be drawn from the implementing measure for electric motors. Based on the regulation, since 2014 only motors with an efficiency rating of IE3 or IE2 when used with a frequency converter for variable speed operation are allowed on the European market. Now thinking this through, it can easily be con-

cluded that the regulation could legally favour a “not-efficient” solution, as for IE2 motors that are operated in continuous (not variable) speed operation and now, for legal compliance, get “enhanced” by a frequency converter for additional losses. Generally the already mentioned rebound effect is an issue that will increase in importance if the system aspect is not considered in an appropriate manner.

- The topic of the embedment of the directive into the total framework can be mentioned in favour of the current approach. Also the mentioned debate along the implementation process can be cited positively in regards to the coverage of “hard” and “soft” system aspects.

## **3.2 Conclusions and Recommendations**

### **3.2.1 Governance instruments**

Concluding from the results of the analysis, the following recommendation to the governing institutions can be given:

- It is essential that a coherent policy mix is developed at EU and Member State level with clear, simple and measurable objectives for all involved players. Measures at EU level could provide Member States with the needed framework and supporting acts, as financing budget for research or tools. Further Attention should be paid to policy predictability, including effects on investment strategies, as well as to the orchestration, of applied governance instruments in regards to political targets. It could support that the possible synergies between the various policies are explored. For instance taxation strategies can support policies through influences consumption (energy, resources), and their underlying political goal.
- Even though the industry has experienced the most significant energy efficiency improvements, still some potential remains. The barriers in the sector are mainly a lack of strong price signals, lack of awareness and training (especially for SMEs), and also lack of long-term policy planning which increases the perception of risk and deters companies from realizing investments. Concerning the legal framework, more implementing measures under Ecodesign Directive could be proposed that would cover commonly used products in industrial process (such as large pumps or furnaces). Custom-made equipment (such as machine tools) and systems could be addressed with generic energy-efficiency requirements, which would then be operationalised by the European Standardisation Organisations. In addition, this would enhance the systems thinking aspect. Im-

portant mobilization of projects in the industry sector could come from energy savings obligations, if imposed on energy companies.

- Measures on awareness raising and increased voluntary engagement of private entities would be also beneficial and knowledge gained from the studies conducted within the directives implementation process (preparatory studies, preparation of work plans, impact assessment) could be used for the preparation of training material.

### **3.2.2 Industry**

Concluding from the results of the analysis, the following recommendation to industry can be given:

- For companies operating in the EEA, a (long term) sustainability strategy is necessary. This strategy should include a defined approach on these issues resulting from the legal framework. Clearly there's no one size fits all approach, depending on the business itself, companies should define their main areas of interest, check their competencies and resources against the required (and if necessary enhance their resources or knowledge) and then strategically engage in the rule setting, from stakeholder consultation to standardization. For SMEs a reactive approach seems to be more reasonable and they might here rely on external resources and competencies (consultants, research institutes) and might make use of associations to stay flexible and to limit utilization of own employees. For big companies more options exist, basically again depending of the nature of business activity, a more proactive approach in this context might make sense to utilizes (new) business opportunities, like for instance through innovations. It should be kept in mind, that sustainability challenges affect everybody; therefore businesses' role in rule setting should be in a supportive way with the target of:
  - Pragmatic, lean processes concerning conformity assessments or the stipulations of regulations itself in regard to the set political goal;
  - (Globally) harmonized business framework, to limit the administrative burden to the benefit of all stakeholders.
- As cost-efficiency or socio-economic aspects today are fundamental in context to regulations in the European Economy Area, there are options for reasonable influencing the legal framework. Besides a company's image in the sustainability context, taking part in the associated discussions and debates with appropriate competencies and reasonable arguments will in the long run improve the perception of the proposals of company's representative. For instance data gained from quantitative methods applied for environmental conscious design can be used here (e.g. to underfeed arguments), maybe even taking planetary boundaries or absolute sustainability into account. Hence the company's activi-

ties will gain in efficiency, as well as there will be a positive effect on the image then.

- For big companies it should be essential to take the complexity of the rule setting in the EU into account. Activities should be triggered on member state as well as European level.

## 4 References

- [Roach 2004] Roach J: 2004: The year global warming got respect. National Geographic News: Reporting Your World Daily, December 29, 2004. [http://news.nationalgeographic.com/news/2004/12/1229\\_041229\\_climate\\_change\\_consensus.html](http://news.nationalgeographic.com/news/2004/12/1229_041229_climate_change_consensus.html); Accessed on 07.01.2016
- [Oerskes 2004] Oreskes N: Behind the Ivory Tower: The Scientific Consensus on Climate Change. *Science* 306, No. 5702 (December 2004). 2004
- [GISTEMP 2015] GISTEMP Team, 2015: GISS Surface Temperature Analysis (GISTEMP). NASA Goddard Institute for Space Studies. Dataset accessed 2016-01-07 at <http://data.giss.nasa.gov/gistemp/>.
- [Hansen 2010] Hansen, J., R. Ruedy, M. Sato, and K. Lo, 2010: Global surface temperature change, *Rev. Geophys.*, 48, RG4004, doi:10.1029/2010RG000345.
- [GUARD 2015] <http://www.theguardian.com/environment/radical-conservation/2015/oct/20/the-four-horsemen-of-the-sixth-mass-extinction>
- [Williams et al 2015] Williams M, Zalasiewicz J, Haff PK, Schwäger C, Barnosky A, Ellis E: The Anthropocene biosphere. *The Anthropocene Review* December 2015 vol. 2 no. 3 196-219. 2015
- [Ehrlich 1971] Ehrlich P, Holdren J: Impact of Population Growth. *Science (American Association for the Advancement of Science)* 171 (3977): 1212–1217. 1971
- [Clini et al 2010] Ed. Clini C, Musu I, Gullino ML: *Sustainable Development and Environmental Management: Experiences and Case Studies*. Springer Science & Business Media. 2010
- [Hall et al 2003] Hall J and Vredenburg H: The Challenges of Innovating for Sustainable Development. *MIT SLOAN Management Review* Fall 2003.
- [Lister et al 2015] Lister J, Poulsen RT, Ponte S: Orchestrating transnational environmental governance in maritime shipping. *Global Environmental Change*. 2015
- [Henriksen, Ponte 2015] Henriksen LF, Ponte S: Form Farm to Flight: Orchestration, Social Networks and the Transnational Environmental Governance of Aviation. *Proceedings of Regulatory Intermediates: Bringing together Domestic and Transnational Regulation*, SASE, London 2-4 July 2015. Tbp.
- [Dinda 2004] Dinda S: Environmental Kuznets Curve Hypothesis: A Survey. *Ecological Economics*. Nr. 49, 2004, S. 431–455. 2004.

[Goldemberg 1998] Goldemberg, J: Leapfrogging Energy Technologies. Energy Policy 2 (10): 729–741. 1998

[IPCC 2007] Intergovernmental Panel on Climate Change: Summary for Policy Makers. Climate Change, the Physical Science Basis, Contribution of Working Group 1 to the Fourth Assessment Report of the Intergovernmental Panel on Climate Change. Cambridge University Press. 2007

[EEA 2015] European Environment Agency: Final energy consumption by sector and fuel. CSI 027 ENER 016. Available on <http://www.eea.europa.eu/data-and-maps/indicators/final-energy-consumption-by-sector-9/assessment>. 2015. Accessed 10.01.16

[COM 2010] Communication from the Commission: EUROPE 2020, a strategy for smart, sustainable and inclusive growth. COM(2010) 2020 final. 2010. [http://ec.europa.eu/europe2020/europe-2020-in-a-nutshell/targets/index\\_en.htm](http://ec.europa.eu/europe2020/europe-2020-in-a-nutshell/targets/index_en.htm). Accessed on 12.12.15

[EC 2020] [http://ec.europa.eu/clima/policies/strategies/2020/index\\_en.htm](http://ec.europa.eu/clima/policies/strategies/2020/index_en.htm). Accessed on 12.12.15

[SEC 2011] COMMISSION STAFF WORKING DOCUMENT IMPACT ASSESSMENT, Accompanying document to the COMMUNICATION FROM THE COMMISSION TO THE EUROPEAN PARLIAMENT, THE COUNCIL, THE EUROPEAN ECONOMIC AND SOCIAL COMMITTEE AND THE COMMITTEE OF THE REGIONS COMMISSION STAFF WORKING DOCUMENT, Energy Efficiency Plan 2011, SEC(2011) 277 final

[SWD 2014] COMMUNICATION FROM THE COMMISSION TO THE EUROPEAN PARLIAMENT AND THE COUNCIL: Energy Efficiency and its contribution to energy security and the 2030 Framework for climate and energy policy, {SWD(2014) 255 final}, {SWD(2014) 256 final}

[2012/27/EU] Directive 2012/27/EU of the European Parliament and of the Council of 25 October 2012 on energy efficiency, amending Directives 2009/125/EC and 2010/30/EU and repealing Directives 2004/8/EC and 2006/32/EC Text with EEA relevance; <http://eur-lex.europa.eu/legal-content/EN/TXT/?qid=1399375464230&uri=CELEX%3A32012L0027>

[2009/125/EC] [Directive 2009/125/EC](#) OF THE EUROPEAN PARLIAMENT AND OF THE COUNCIL of 21 October 2009 for establishing a framework for the setting of ecodesign requirements for energy-related products (recast). <http://eur-lex.europa.eu/legal-content/EN/ALL/?uri=CELEX%3A32009L0125>. 2009

[2005/32/EC] Directive 2005/32/EC OF THE EUROPEAN PARLIAMENT AND OF THE COUNCIL of 21 October 2009 for establishing a framework for the setting of ecodesign requirements for energy-using products. 2005

[EUP 2015a] EUP Network, Background: <http://www.eup-network.de/background/ecodesign-directive/>. Accessed on 15.12.2015.

[EUP 2015b] EUP Network, Overview product groups: <http://www.eup-network.de/product-groups/overview-ecodesign/>. Accessed on 15.12.2015.

[EUP 2015c] EUP Network, EuP scheme: [http://www.eup-network.de/fileadmin/user\\_upload/Hintergrund/EuP-Dokumente/EuP\\_scheme.pdf](http://www.eup-network.de/fileadmin/user_upload/Hintergrund/EuP-Dokumente/EuP_scheme.pdf) . Accessed on 15.12.2015.

[COM 2008] Communication from the Commission to the Council and the European Parliament - Establishment of the working plan for 2009-2011 under the Ecodesign Directive, /\* COM/2008/0660 final \*/

[SWD 2012] Establishment of the Working Plan 2012-2014 under the Ecodesign Directive, SWD(2012) 434 final

[BIO 2014] BIO by Deloitte, Oeko-Institut and ERA Technology; Preparatory Study to establish the Ecodesign Working Plan 2015-2017 implementing Directive 2009/125/EC. Draft Final Report prepared for the European Commission (DG ENTR). 2014

[MEERP 2015] Methodology for the Ecodesign of Energy-related Products. <http://www.meerp.eu/>. Accessed on 15.12.2015

[EU 2014] COMMISSION REGULATION (EU) No 4/2014 of 6 January 2014 amending Regulation (EC) No 640/2009 implementing Directive 2005/32/EC of the European Parliament and of the Council with regard to ecodesign requirements for electric motors. 2014

[EC 2015a] European Commission, DG Energy: Energy-efficient products, electric motors. <https://ec.europa.eu/energy/en/topics/energy-efficient-products/electric-motors>. Accessed on 16.12.15.

[Dovers, Handmer 1992] Stephen R. Dovers, John W. Handmer: Uncertainty, sustainability and change. Global Environmental Change. 1992

[Zaman, Goschin 2010] Zaman, G. and Goschin, Z.: Multidisciplinary, Interdisciplinarity and Transdisciplinarity: Theoretical Approaches and Implications for the Strategy of Post-Crisis Sustainable Development. Theoretical and Applied Economics Volume XVII (2010), No. 12(553), pp. 5-20. 2010

[Bulkeley et al 2012] Harriet Bulkeley, JoAnn Carmin, Vanesa Casta'n Broto, Gareth A.S. Edwards, Sara Fuller: Climate justice and global cities: Mapping the emerging discourses; Global Environmental Change. 2012

- [Dryzek, Stevenson 2011] John S. Dryzek, Hayley Stevenson: Global democracy and earth system governance. *Ecological Economics*. 2011
- [Mansbridge 1999] Mansbridge, J: Everyday talk in the deliberative system. *Deliberative Politics*. Oxford University Press, Oxford, pp. 211–239. 1999
- [Bjørn, Hauschild 2012] Bjørn, A Hauschild M: Absolute versus Relative Environmental Sustainability. *Research and Analysis*; Volume 17, Number 2. 2012
- [ILCD 2010] European Commission - Joint Research Centre - Institute for Environment and Sustainability: International Reference Life Cycle Data System (ILCD) Handbook - General guide for Life Cycle Assessment - Detailed guidance. First edition March 2010. EUR 24708 EN. Luxembourg. Publications Office of the European Union; 2010
- [Steffen et al 2004] Steffen, W et al: Global change and the earth system, A planet under pressure. The IGBP series, Springer. 2004
- [Steffen et al 2015] Steffen W, Richardson K, Rockstrom J, Cornell SE, Fetzer I, Bennett EM et al: Planetary boundaries: guiding human development on a changing planet. *Science* 347:736. 2015
- [McDonough, Braungart 2002] McDonough, W and M. Braungart: *Cradle to cradle — Remaking the way we make things*. New York, NY, USA: North Point Press. 2002
- [Bjørn, Hauschild 2015] Bjørn A and Hauschild M: Introducing carrying capacity-based normalisation in LCA: framework and development of references at midpoint level. *Int J Life Cycle Assess* (2015) 20:1005–1018. 2015
- [EC 2015b] European Commission, Climate Action Webpage, News from 18.11.2015: EU meets Kyoto targets under first commitment period (2008-2012). [http://ec.europa.eu/clima/policies/strategies/progress/kyoto\\_1/index\\_en.htm](http://ec.europa.eu/clima/policies/strategies/progress/kyoto_1/index_en.htm). Accessed on 09.01.2016



PROJECT REPORT: LIFE CYCLE MANAGEMENT AT  
SIEMENS PROCESS INDUSTRIES AND DRIVES (PD  
DIVISION)

# **Project Report: Life cycle management at Siemens Process Industries and Drives (PD Division)**

DTU course –

42377 „Life Cycle Management in Industry“

Spring 2016

**Johannes Auer**

DTU MAN QSA

closed 04. May 2016

**Siemens AG**

PD EHS, Gleiwitzer Str. 555, 90475 Nürnberg, Germany

# Content

<b>Content</b> .....	<b>2</b>
<b>Figures</b> .....	<b>3</b>
<b>List of tables</b> .....	<b>3</b>
<b>Introduction</b> .....	<b>4</b>
1.1 Siemens AG.....	4
1.2 Siemens Division Process Industries & Drives .....	5
<b>2 Sustainability matters of Siemens AG</b> .....	<b>6</b>
<b>3 Sustainability approach of Siemens AG and the Division PD</b> .....	<b>8</b>
3.1 Sustainability in Corporate Context .....	8
3.1.1 Organizational background .....	8
3.1.2 Corporate Approach .....	9
3.1.3 Sustainability reporting / KPIs .....	10
3.1.4 Life cycle thinking (LCT) .....	14
3.2 Sustainability aspects in context to Siemens PD operations .....	15
3.2.1 Organizational background .....	15
3.2.2 PD approach .....	15
3.2.3 Reporting / KPIs .....	16
3.2.4 Environmental conscious design approach .....	17
<b>4 Analysis</b> .....	<b>18</b>
4.1 Sustainability in corporate context: Siemens AG approach .....	18
4.2 Sustainability in business context: PD's Approach.....	18
<b>5 References</b> .....	<b>20</b>

## Figures

Figure 1: Siemens Divisions as clusters of the operations.....	4
Figure 2: Current key points in the development of the Process Industries and Drives (PD) Division. ....	5
Figure 3: The 5 Megatrends – basis for Siemens strategic orientation.....	6
Figure 4: Principles of Siemens sustainability approach.....	9
Figure 5: Siemens core topics concerning sustainability.....	10
Figure 6: Siemens main sustainability goal is the cut the CO2 emissions of its operations in 2030 by 100%.....	13
Figure 7: Screenshot of the EP Standard on "Environmentally compatible product and system design" showing the activities to be incorporated by oprative organizational units in their product life cycle management processes.....	14
Figure 8: The conepect of the Integrated Drive System (IDS) - The Integration of 3 dimensions provides customer benefit in terms of productivity, reliability and efficiency.....	16

## List of tables

Table 1: Identification of the main sustainability aspects associated with the Megatrends.....	6
Table 2: Sustainability action fields displayed with associated, reported KPIs. The selected KPIs to the action field are not all but just examples.....	12

# Introduction

## 1.1 Siemens AG

Siemens AG (Berlin and Munich) is a global technology powerhouse that has stood for engineering excellence, innovation, quality, reliability and internationality for more than 165 years. The company is active in more than 200 countries, focusing on the areas of electrification, automation and digitalization. One of the world's largest producers of energy-efficient, resource-saving technologies, Siemens is No. 1 in offshore wind turbine construction, a leading supplier of gas and steam turbines for power generation, a major provider of power transmission solutions and a pioneer in infrastructure solutions as well as automation, drive and software solutions for industry. The company is also a leading provider of medical imaging equipment – such as computed tomography and magnetic resonance imaging systems – and a leader in laboratory diagnostics as well as clinical IT. In fiscal 2015, which ended on September 30, 2015, Siemens generated revenue of €75.6 billion and net income of €7.4 billion. At the end of September 2015, the company had around 348,000 employees worldwide. [1]

Siemens clusters its core operations into 10 Divisions, as displayed in Figure 1, whereas focus in the context of the study is the Process Industries & Drives (PD) Division.



Figure 1: Siemens Divisions as clusters of the operations

## 1.2 Siemens Division Process Industries & Drives

*Measurably increase your productivity and improve your time to market – with innovative, integrated technology across the entire lifecycle.*

Siemens PD aims support customers in continuously improving the reliability, safety, and efficiency of products, processes and plants. PD’s Business Units (BU) are Large Drives (LD), Process Automation (PA) and Mechanical Drives (MD) with products and solutions ranging from high voltage electrical motors, measuring and control equipment to gears and couplings. PD was founded after the last reorganization within Siemens in 2014, to emphasis on the (indiscrete) process industries like chemicals, pharma or mining. [2]

Core offerings are future-proof automation, drive technologies, industrial software, and services based on platforms like Totally Integrated Automation (TIA) or Integrated Drive Systems (IDS) to develop sustainable solutions across the entire lifecycle – from design and engineering to modernization. Offerings include standardized components, wherever possible, complemented with industry-specific (application-specific) solutions to meet customers’ specific needs in all industry segments. This enables an increased availability of the systems and solutions over the long term, with a strong focus on resource efficiency. [3]

The process industry is one of the core businesses of Siemens. Countless applications, installed throughout a wide variety of industries, demonstrate the expertise. Current developments focus on application specific solutions (e.g. IDS), the integration of “Industry 4.0” aspects, like for instance remote maintenance and associated services and are displayed in Figure 2.



Figure 2: Current key points in the development of the Process Industries and Drives (PD) Division.

## 2 Sustainability matters of Siemens AG

Siemens is, as introduced in the previous chapter, a much diversified business on a global scale. All sustainability aspects do have or can have – more or less – impact on the company and its operations, from the supply chain management to the product life cycle management processes. Siemens strategy is strongly correlating with sustainability topics through the using the 5 so-called megatrends – Digitalization, Urbanization, Demographic Change, Globalization and Climate Change – for orientation concerning the company’s development, e.g. the organizational set-up and the portfolio. The Megatrends are visualized in Figure 3 [4].

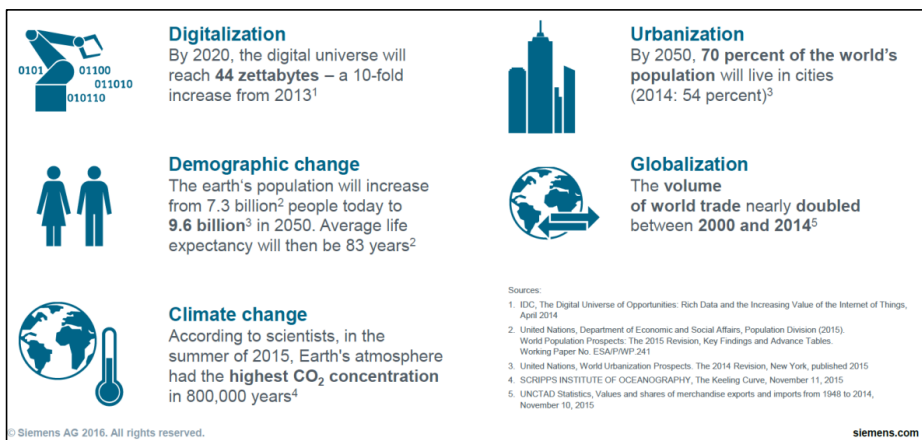

Figure 3: The 5 Megatrends – basis for Siemens strategic orientation.

Table 1 now shows the main sustainability aspects of these Megatrends, which should be addressed by Siemens products, services and solutions or have to be coped with in its own operations.

Table 1: Identification of the main sustainability aspects associated with the Megatrends.

Megatrend	Remark	Main sustainability aspects
Digitalization	Growth of data processing centers versus reduced resource utilization for prototypes or planning	Resource consumption and associated impacts (Global warming, resource depletion / scarcity)
Demographic change	Population growth and increase of the living	Resource consumption (Global warming, resource

	standards will affect resource consumption	depletion / scarcity)
Climate Change	Effects of climate change have to be minimized and are strongly connected to the consumption of fossil fuels	Global warming; Biodiversity
Urbanization	Growth of megacities which will require an improved management of emissions (connected to resource consumption) to keep / improve living standards	Particulate matter; Land occupation; Acidification and Global warming; water use; waste management
Globalization	Increase of shipments as well as generally travel	Global warming; Biodiversity; Water use

Summarizing the aspects pointed out above it can be concluded that the main sustainability challenge Siemens has to have on the agenda is climate change and further impacts associated with resource consumption, like ozone depletion and particulate matter. Concerning the economic pillar, as well as the social aspects of sustainability, the globalization provides additional challenges as an increasingly complex supply chain and regulative framework.



## 3 Sustainability approach of Siemens AG and the Division PD

### 3.1 Sustainability in Corporate Context

#### 3.1.1 Organizational background

In 2010 Siemens reacted to the up and coming awareness on sustainability topics by installing a corporate (core) unit for Sustainability, the Sustainability Office, which is currently allocated to Corporate Development, Strategy, headed by the Sustainability Director. Mr Roland Busch, Member of the Managing Board, is Chief Sustainability Officer (CSO). The CSO steers all sustainability related activities through chairing the Siemens Sustainability Board (SSB), which consist out of mandated representatives from countries, divisions and corporate functions, deciding about sustainability related activities and initiatives. The Sustainability Office is headed by the Sustainability Director and in charge of driving and supporting these activities. [5]

Especially an often cited McKinsey study [6], stating companies having sustainability included to their strategic orientation to be more successful in the long run, seemed to be a driver for companies to emphasis their sustainability engagement in external communication. Today Siemens claims the following sustainability slogan:

*Our understanding of sustainability is fully based on our company values – responsible, excellent, innovative. We define sustainable development as the means to achieve profitable and long-term growth. At Siemens we have a clear commitment to think and act in the interest of future generations, balancing People, Planet and Profit. [4]*

Governance owner of most of the sustainability related process, like environmental protection, occupational health and safety, as well as health management is the corporate core unit “Environment, Health and Safety” (EHS), currently allocated to Human Resources (HR): HR EHS. Under German jurisdiction, German shareholder companies have to nominate one member of the managing board as governance owner in regards to the fulfilment of legal requirements, being accountable for the company. Siemens as a company works with a three level organization structure concerning the delegation of responsibilities and accountability. Through the EHS principles [5], the member of the managing board who’s in charge of EHS, delegates his responsibility to the Divisions CEOs, who then can delegate their responsibility to another, the third, level, like for instance the Business Unit (BU) CEO or site managers (factory managers, project man-

agers). The delegation of responsibilities alternates the respective duties to organizational and controlling tasks. Currently Mrs Janina Kugel (MBM, Head of HR) is in that position.

### 3.1.2 Corporate Approach

In the process of framing the sustainability approach for the company, the principles shown in Figure 4 were defined, addressing all 3 pillars of sustainability.

<p><b>PROFIT</b></p> <ul style="list-style-type: none"><li>&gt; We contribute to our customers' competitiveness with our products, solutions and services.</li><li>&gt; We partner with our customers to identify and develop sustainability-related business opportunities.</li><li>&gt; We operate an efficient and resilient supply chain through a supplier code of conduct, risk management and capacity building.</li><li>&gt; We proactively engage with our stakeholders to manage project and reputational risks and identify business-relevant trends.</li><li>&gt; We adhere to the highest compliance and anticorruption standards and promote integrity via the Siemens Integrity Initiative.</li></ul> <p><b>PLANET</b></p> <ul style="list-style-type: none"><li>&gt; We enable our customers to increase energy efficiency, save resources and reduce carbon emissions.</li><li>&gt; We develop our products, solutions and services based on a life-cycle perspective and sound eco-design standards.</li><li>&gt; We minimize the environmental impacts of our own operations by applying environmental management programs.</li></ul> <p><b>PEOPLE</b></p> <ul style="list-style-type: none"><li>&gt; We contribute to the sustainable development of societies with our portfolio, local operations and thought leadership.</li><li>&gt; We foster long-term relationships with local societies through Corporate Citizenship projects jointly carried out with partners.</li><li>&gt; We live a zero-harm culture and promote the health of our employees.</li><li>&gt; We live a culture of leadership based on common values, an innovation mindset, a people orientation and diversity.</li></ul>
---

Figure 4: Principles of Siemens sustainability approach

Looking at the principles addressing aspects of “the planet”, Siemens explicitly states to take the life cycle perspective into account, including eco design standards.

In that context the current core topics of Siemens sustainability approach are shown in Figure 5.

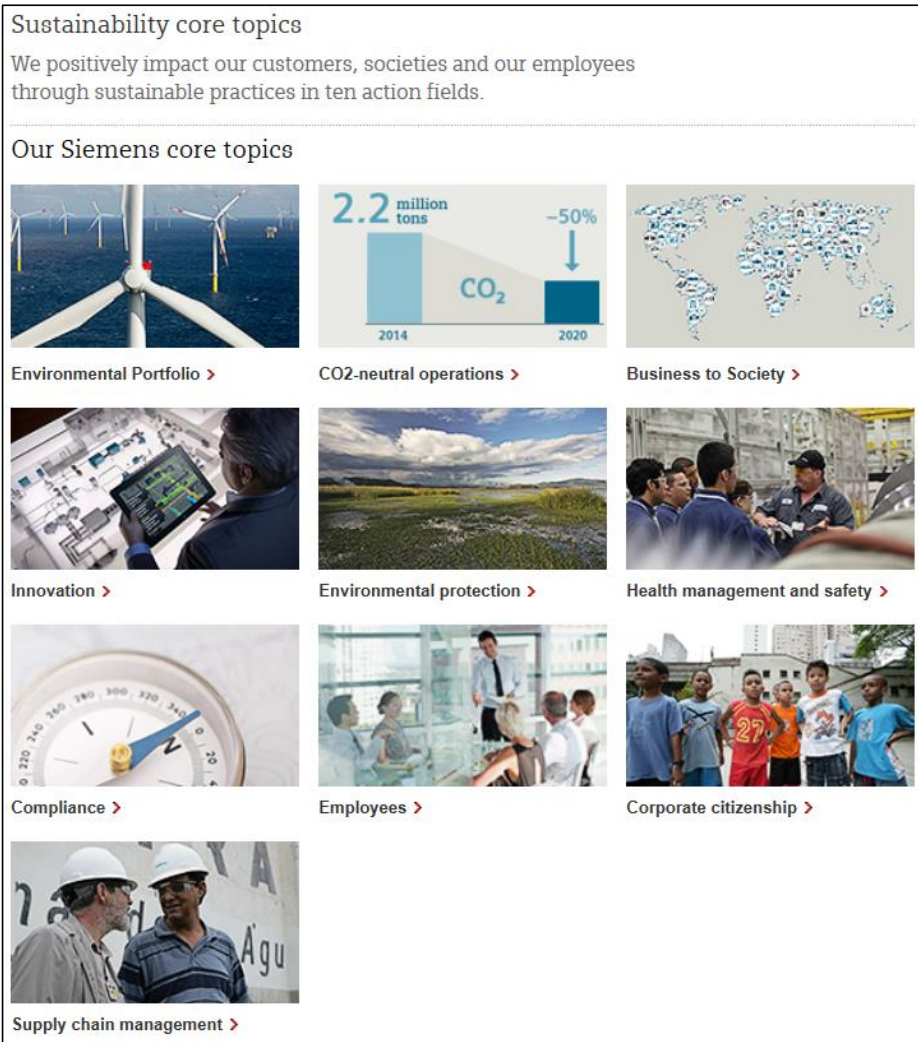

Figure 5: Siemens core topics concerning sustainability

Out of these 10 action fields, three are picked for further analysis in regards to life cycle management in the context to Siemens PD's operations:

- Environmental Portfolio
- Environmental Protection
- Innovations

### 3.1.3 Sustainability reporting / KPIs

In Siemens' commitment to sustainability has received public recognition: The Company achieved the highest possible score in the Carbon Disclosure Project (CDP), the

world's largest climate-protection survey. For the transparency of its reporting on the opportunities and risks associated with climate change, Siemens received 100 (2014: 99) out of 100 possible points. In addition, Siemens' efforts to achieve energy efficiency and cut CO2 emissions enabled the company to reach Band A, the highest performance range. As a result, Siemens is also included in the Carbon Performance Leadership Index. In the most recent Dow Jones Sustainability Index (DJSI) ranking (2015), Siemens ranks among the leaders by taking second place in the Industrial Conglomerates area, which comprises 43 companies, including General Electric, 3M, Philips and Toshiba. Siemens received a very positive overall assessment by scoring 90 out of a maximum of 100 points. The company has been represented in the DJSI every year since 1999, when the index was first published. The DJSI takes into account environmental and social factors as well as economic criteria. This year, Siemens received top marks in nine of the 20 DJSI categories, including customer and environmental management as well as corporate citizenship. [8]

Underlying these rankings is the Siemens Sustainability Information (SI), issued every year along with the Siemens Annual Report (AR). The report primarily sums up actions taken and the performance in regard to the 10 principles of sustainability within the respective fiscal year. It's guided by the G4 Sustainability Reporting Guidelines of the Global Reporting Initiative (GRI) and the recommendations of the Global Compact and Transparency International regarding anticorruption reporting. The content and especially the related facts and figures are checked by an assurance review by an independent body, for instance in 2015 by Ernst & Young Wirtschaftsprüfungsgesellschaft GmbH, for "limited assurance".

The main KPIs associated with the three action fields picked above are:

Table 2: Sustainability action fields displayed with associated, reported KPIs. The selected KPIs to the action field are not all but just examples.

Action field	Associated KPIs (among others)															
Environmental Portfolio	<p>  <b>Key performance indicators</b></p> <table border="1"> <thead> <tr> <th></th> <th colspan="2">Fiscal year</th> </tr> <tr> <th></th> <th>2015</th> <th>2014<sup>1</sup></th> </tr> </thead> <tbody> <tr> <td>Revenue generated by the Siemens Environmental Portfolio (continuing operations, in billions of €)</td> <td>32.7</td> <td>31.5</td> </tr> <tr> <td>Annual customer reductions of carbon dioxide emissions generated by elements from the Siemens Environmental Portfolio newly installed in the reporting year (continuing operations, in millions of metric tons)</td> <td>58</td> <td>57</td> </tr> <tr> <td>Accumulated annual customer reductions of carbon dioxide emissions generated by elements from the Siemens Environmental Portfolio within the reporting year (continuing operations, in millions of metric tons)</td> <td>487</td> <td>428</td> </tr> </tbody> </table>		Fiscal year			2015	2014 <sup>1</sup>	Revenue generated by the Siemens Environmental Portfolio (continuing operations, in billions of €)	32.7	31.5	Annual customer reductions of carbon dioxide emissions generated by elements from the Siemens Environmental Portfolio newly installed in the reporting year (continuing operations, in millions of metric tons)	58	57	Accumulated annual customer reductions of carbon dioxide emissions generated by elements from the Siemens Environmental Portfolio within the reporting year (continuing operations, in millions of metric tons)	487	428
		Fiscal year														
		2015	2014 <sup>1</sup>													
	Revenue generated by the Siemens Environmental Portfolio (continuing operations, in billions of €)	32.7	31.5													
	Annual customer reductions of carbon dioxide emissions generated by elements from the Siemens Environmental Portfolio newly installed in the reporting year (continuing operations, in millions of metric tons)	58	57													
Accumulated annual customer reductions of carbon dioxide emissions generated by elements from the Siemens Environmental Portfolio within the reporting year (continuing operations, in millions of metric tons)	487	428														
<p>  <sup>1</sup> Prior year numbers were adjusted to reflect the deletion of the environmental technologies selection criteria in order to ensure year-on-year comparability.</p>																
Environmental Protection	<p>  <b>Indicators (in %)</b></p> <table border="1"> <thead> <tr> <th></th> <th>Fiscal year 2015</th> </tr> </thead> <tbody> <tr> <td>Energy efficiency improvement compared with baseline in fiscal 2014<sup>1,2</sup></td> <td>-1.0</td> </tr> <tr> <td>Waste efficiency improvement compared with baseline in fiscal 2014<sup>1</sup></td> <td>-2.0</td> </tr> <tr> <td>Waste for disposal reduction compared with baseline in fiscal 2014</td> <td>6.1</td> </tr> <tr> <td>Carbon dioxide emission efficiency improvement compared with baseline in fiscal 2014<sup>1</sup></td> <td>1.1</td> </tr> </tbody> </table>		Fiscal year 2015	Energy efficiency improvement compared with baseline in fiscal 2014 <sup>1,2</sup>	-1.0	Waste efficiency improvement compared with baseline in fiscal 2014 <sup>1</sup>	-2.0	Waste for disposal reduction compared with baseline in fiscal 2014	6.1	Carbon dioxide emission efficiency improvement compared with baseline in fiscal 2014 <sup>1</sup>	1.1					
		Fiscal year 2015														
	Energy efficiency improvement compared with baseline in fiscal 2014 <sup>1,2</sup>	-1.0														
	Waste efficiency improvement compared with baseline in fiscal 2014 <sup>1</sup>	-2.0														
	Waste for disposal reduction compared with baseline in fiscal 2014	6.1														
Carbon dioxide emission efficiency improvement compared with baseline in fiscal 2014 <sup>1</sup>	1.1															
<p>  <sup>1</sup> Adjusted for currency translations and portfolio effects.</p>																
<p>  <sup>2</sup> Indicator incorporates weighted calculations related to the primary fuels consumed in generating the energy used at our sites and the amount of energy used to extract, convert and distribute the fuels consumed.</p>																

<b>Life-cycle assessments and environmental product declarations</b> (percentage of revenue covered) <sup>1</sup>			
		Fiscal year	
		2015	2014
Full-scale LCAs		69	69
Screening LCAs		50	52
EPD		70	70
<p><sup>1</sup> We consider the revenue of a Business Unit in relation to Siemens revenue once we have carried out at least one "Full-scale LCA," "Screening LCA," or "EPD" for their products or systems. No product-related coverage is calculated.</p>			
Innovation	n/a; Primarily just qualitative statements of R&D focus topics connected with sustainability; R&D budget per business volume is reported and could be seen as a KPI.		

Most aspects of the sustainability principles and especially the action field are driven by corporate programs, setting specific targets for the operative units in regard to energy efficiency, waste management, substance management etc. The latest target Siemens published externally in that context was its statement to be carbon neutral by 2030, displayed in Figure 6, followed up by corresponding actions [9].

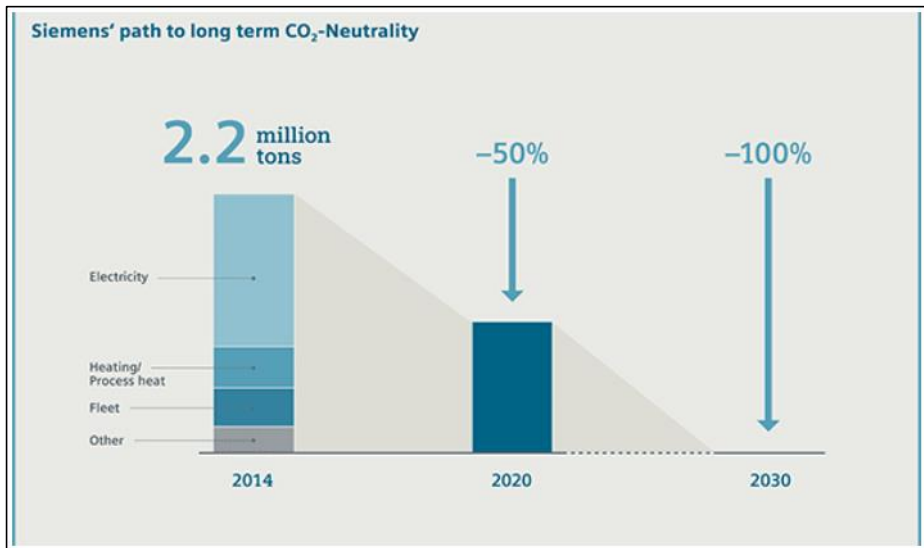

Figure 6: Siemens main sustainability goal is the cut the CO<sub>2</sub> emissions of its operations in 2030 by 100%

### 3.1.4 Life cycle thinking (LCT)

In that context, one whole chapter of the Siemens Sustainability Information addresses the topic of applied life cycle thinking, emphasizing the compulsory EHS standard for “Environmental conscious design”, implementing the IEC 62430 Standard, for consideration of the whole product life cycle. Key points are:

- Consideration of environmental aspects of the products life cycle during development
- Management of critical substances (harmful and/or scarce)
- Promotion of the use of life cycle assessment methodology according to ISO 14040/44
- Internal environmental declaration program according to ISO 14025

The principle of LCT is laid out in a corresponding Environmental Protection (EP) standard (internal instruction, implemented via the EHS principles). This Corporate standard has to be implemented by operative organizational units in their product life cycle management (PLM) processes. It addresses certain questions to be asked within the development of offerings (products, services, systems). Figure 7 indicatively displays activities to be incorporated at the corresponding life cycle stages.

<b>4.1.1 Activities on environmentally compatible product design</b>	
<i>Planning and development aspects</i>	
1	Identifying, documenting and implementing regulatory and normative requirements as well as requirements of customers and other stakeholders.
2	Determining, evaluating and documenting the relevant environmental aspects throughout the entire product life cycle, bearing potential competitive advantages in mind.
3	Assessing and if necessary developing a documented concept for the end of life treatment of the product (reuse, recycling, disposal), with estimated costs.
4	Deriving environment-related design objectives based on the previous steps 1 to 3, establishing these design objectives in the design specification and tracking the achievement of these objectives.
<i>Procurement and manufacturing aspects</i>	
5	Minimizing product weight, variety of materials as well as number and variety of product parts (components). Using recyclable materials as far as possible.
6	Minimizing use of hazardous materials, energy consumption and production waste in the manufacturing of products by means of optimized product design and manufacturing processes.
7	Taking account of environmental and dangerous goods aspects in the selection and procurement of materials, semi-finished products, components and external products, such as: <ul style="list-style-type: none"> <li>• Legal requirements</li> <li>• Avoidance and declaration requirements<sup>1</sup></li> <li>• Requirements regarding battery-containing products<sup>2</sup></li> <li>• Dangerous goods aspects<sup>3</sup></li> </ul> Requesting information from suppliers in this regard.

Figure 7: Screenshot of the EP Standard on "Environmentally compatible product and system design" showing the activities to be incorporated by operative organizational units in their product life cycle management processes.

## **3.2 Sustainability aspects in context to Siemens PD operations**

### **3.2.1 Organizational background**

As mentioned above the accountability for sustainability related topics in regards to EHS delegated by the EHS principles to the Division CEO. The Division CEO again delegates his responsibilities topic specific along the chain of command to the third management level, the Business Unit CEO and the factory managers. The remaining duties for organization and controlling are picked up by the respective functional department: PD EHS. The Division CEO also mandates a representative to the SSB, currently from the Technology and Innovation department. The corresponding reporting obligations – a.o. environmental and occupational safety reporting, environmental portfolio – are picked up by these departments respectively. Other functional departments are also affected, but not to that extent, like for instance supply chain management or financial reporting, where the corporate standards, derived from the sustainability principles, like the Code of Conduct etc., have to be implemented.

### **3.2.2 PD approach**

Focus in regards to sustainable innovations in the PD Division is the customer productivity, either through providing solution for reducing resource consumption and/or by increasing availability. One key initiative in this context is the Integrated Drive System (IDS), providing integrated products for application specific solutions of complex drive tasks [3]. The concept is shown in Figure 8. Another key activity associated is called Energy Efficiency @ Industry (EE@I), synchronizing BUs' activities in regard to energy efficiency. Both initiatives are set up on divisional level to provide the necessary cross-BU framework. Both initiatives cover aspects of product and service development, as well as sales and marketing, therefore the whole life cycle is taken into account.









Integrated Drive Systems		Examples	Customer benefit
<b>Horizontal Integration</b> Integration of drive components to create coordinated drive systems		 SIMOGEAR	<ul style="list-style-type: none"> <li>• Productivity</li> <li>• Reliability</li> <li>• Efficiency</li> </ul>
<b>Vertical Integration</b> Integration of the Drive System in the TIA World		 TIA Portal – V12	
<b>Lifecycle Integration</b> Tools and services throughout the whole life cycle		 Condition Monitoring	

Figure 8: The concept of the Integrated Drive System (IDS) - The Integration of 3 dimensions provides customer benefit in terms of productivity, reliability and efficiency.

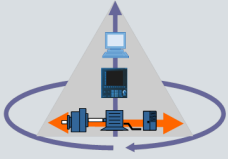
Additionally for EHS an Integrated Management System is in place for facilitating the continuous improvement of EHS related processes and performance. Based on defined criteria (e.g. energy consumption, waste amount, substances) locations have to have a certified management system, according to ISO 14001 and OSHAS 18001, in place. Currently the implementation of main aspects of the Energy Management System according to ISO 16001 is ongoing. Corresponding and further duties in that context are realized by conduction assessments of the EHS performance of the BUs and locations in certain time periods. Key aspects are then discussed with the management in the annually EHS Management Review.

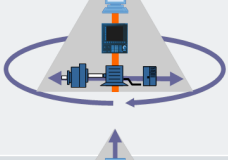
### 3.2.3 Reporting / KPIs

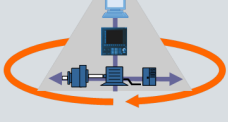
The reporting on divisional level facilitates the Corporate reporting, therefore there's no additional external report on sustainability aspects of the Divisions. The facts and figures for the KPIs are monitored and controlled by the respective functional departments. Concerning the core activities, especially related to EHS, mentioned above, PD has implemented an EHS program; picking up the corporate activities mirrored against PD's operations and evaluated stakeholder needs. Within the program targets are set for the BUs and factories for instance in regards to energy efficiency and waste management, as well as the application of life cycle assessments. The program's progress is monitored annually corresponding to the collection of the data for the sustainability infor-

mation report. One KPI corresponding to sustainability, the Loss Time Incident Frequency Rate (LTIFR) is also part of the monthly performance report of the factories.

#### **3.2.4 Environmental conscious design approach**

Basis of the life cycle management at Siemens PD is the Corporate EHS standard for environmental conscious design, which is based on the IEC 62430 standard. PD EHS in the name of the Division CEO issued a corresponding process instruction, PI63, translating the general requirements from the corporate approach into a business perspective. The requirements then have to be integrated by the business units into their PLM process. The implementation then is controlled biannually via assessments. Core principle of the standard, corresponding to the EP standard is the identification of relevant environmental aspects of business offerings within the phase “plan”, to tackle them according within the phase “define” and check the implementation before “commercialization”. The approach is basically a qualitative checklist approach, defining relevant questions to certain project milestones questions. A quantitative eco design approach is addressed and motivated additionally through (i) having life cycle assessment (LCA) listed as an optional tool and (ii) by providing an extensive framework for conducting these in terms so called product category rules [10].

Generally speaking the main challenge of a diversified, global business, like the Division PDs is, is dealing with legal and sector specific requirements for products, therefore the primary target of this approach is to cope with this and assure compliance towards applicable global substances, waste or energy efficiency regulations. A strategic, 10 year time horizon, approach is ensured by a division specific environmental, health and safety program issued by the Division CEO which includes further development of the life cycle management approach by systematically applying the life cycle assessment methodology to evaluate environmental aspects of products and solutions life cycle. Applying the LCA methodology according to ISO 14040/44 and the ILCD handbook enables companies to assess the main environmental impacts of each of the products life cycle stages and their main drivers. These therefore can be considered in the further development of technological innovations or business cases accordingly.

## 4 Analysis

### 4.1 Sustainability in corporate context: Siemens AG approach

Overall: Looking at the corporate sustainability approach by analysing the available information and the internal implementation, it seems to be a rather exhaustive approach, yet underpinned by defined tasks to business functions in regards to the sustainability aspects of the company's operations. The third party verified annual sustainability report as annex to the annual report, provides extensive information on the performance in 10 defined action fields, representing "sustainability", via KPIs. Sustainability reporting related ratings and rankings testify a good to very good performance, continuously improved in the last years. Finally it can be concluded that there's a good match of the company's actions and the KPIs defined for the performance measurement.

Room for improvement: One key aspect of efficiently integrating eco design aspects to the life cycle management processes of a company's operations, especially from corporate perspective, is to balance between effort and resources needed for leveraging gains by potential synergy effects through defining the business framework on corporate level. To assure this internal "debates" between the company's core units and operative businesses should be basis for developing the company's approach in terms of defining organizational and processual set-up within a strategic perspective. This assures continuous improvement by adapting organization and processes according to the business development and needs, as well as a mutual understanding of the corporate requirements, driven from investors and shareholders, as well as the business requirements, driven by customers and their branches by all organizational level.

### 4.2 Sustainability in business context: PD's Approach

Overall: Looking at the company's sustainability approach in context to a Divisions business it can be stated that the approach still is extensive, with life cycle management including eco design aspects as the backbone. The company's general approach is translated to the Division's business, by further outlining and defining details of the life cycle management. Still there's enough room for the respective Business Units with product responsibility to fine-tune these aspects depending on the business. Today the main eco design aspect in the process industries and drives product life cycle management is energy efficiency; concerning sustainability aspects of its operations, the focus points are the energy and resource efficiency of the factories, as well as the Lost Time Incident Frequency Rate.

Room for Improvement: Based on internal studies [11], the key aspect for the further development of the life cycle management approach could be to switch the “eco design” perspective from individual products (or product families) towards the targeted applications and system design by quantitative measures. This would provide a holistic perspective and would also tackle the portfolio, innovation management but requires further development concerning the LCA modelling framework and its implementation in the respective process steps.

## 5 References

- [1] Siemens AG: <http://www.siemens.com/about/en/>; Accessed 04.05.16
- [2] Siemens PD: <http://www.siemens.com/about/en/businesses/process-industries-and-drives.htm>; Accessed 04.05.16
- [3] Integrated Drive System:  
<http://www.industry.siemens.com/topics/global/en/integrated-drive-systems/Pages/default.aspx>; Accessed 04.05.16
- [4] Siemens Sustainability & Citizenship:  
<http://www.siemens.com/about/sustainability/en/index.php>
- [5] Siemens Sustainability Information 2015:  
[http://www.siemens.com/about/sustainability/pool/en/current-reporting/siemens\\_sustainability\\_information2015.pdf](http://www.siemens.com/about/sustainability/pool/en/current-reporting/siemens_sustainability_information2015.pdf); Accessed 04.05.16
- [6] McKinsey: The Business of Sustainability (2011);  
<http://www.mckinsey.com/business-functions/sustainability-and-resource-productivity/our-insights/the-business-of-sustainability-mckinsey-global-survey-results>;  
Accessed 04.05.16
- [7] Siemens Circular No. 171 “Principles of Environmental Protection, Health Management and Safety”; Intranet:  
[https://circulars.siemens.com/documents/circulardownload.aspx?id=sc\\_171.pdf](https://circulars.siemens.com/documents/circulardownload.aspx?id=sc_171.pdf); Accessed 04.05.16
- [8] Siemens AG: Siemens receives top marks in world’s largest climate-protection ranking; <https://www.siemens.com/press/PR2015110069COEN>; Accessed 04.05.16
- [9] Siemens AG: Siemens to be climate neutral by 2030;  
[http://www.siemens.com/press/en/feature/2015/corporate/2015-09-co2-neutral.php?content\[\]=Corp](http://www.siemens.com/press/en/feature/2015/corporate/2015-09-co2-neutral.php?content[]=Corp); Accessed 04.05.16
- [10] Siemens AG: DFPD63: Environmentally-conscious product design, environmental aspects and material declaration; Intranet:  
[https://circulars.siemens.com/documents/circulardownload.aspx?id=dfpd63\\_en.pdf](https://circulars.siemens.com/documents/circulardownload.aspx?id=dfpd63_en.pdf);  
Accessed 04.05.16
- [11] J. Auer, J.-M. Schäfer, N. Bey: Comparative assessment of economic and environmental performance of an modernized manufacturing system for glass containers – are electrical drives really preferable? Draft – To be published 2016

## ANNEX C: PUBLICATIONS

**JP-I: COMBINED LIFE CYCLE ASSESSMENT AND LIFE  
CYCLE COSTING IN THE ECO-CARE-MATRIX – A  
CASE STUDY ON THE PERFORMANCE OF A  
MODERNIZED MANUFACTURING SYSTEM FOR GLASS  
CONTAINERS**

**JOURNAL OF CLEANER PRODUCTION 141 (2017) 99-109**

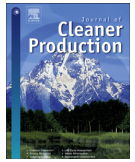

# Combined Life Cycle Assessment and Life Cycle Costing in the Eco-Care-Matrix: A case study on the performance of a modernized manufacturing system for glass containers



Johannes Auer <sup>a, b, \*</sup>, Niki Bey <sup>b</sup>, Johannes-Marius Schäfer <sup>c</sup>

<sup>a</sup> Department for Environment, Health & Safety, Process Industries & Drives Division, Siemens AG, 90475 Nuremberg, Germany

<sup>b</sup> Department of Management Engineering, Division for Quantitative Sustainability Assessment, Technical University of Denmark, 2800 Kgs. Lyngby, Denmark

<sup>c</sup> Faculty for Environmental Science, TU Dresden, 01062 Dresden, Germany

## ARTICLE INFO

### Article history:

Received 18 May 2016

Received in revised form

25 July 2016

Accepted 20 August 2016

Available online 1 September 2016

### Keywords:

Life Cycle Assessment (LCA)

Life Cycle Costing (LCC)

Manufacturing system

Individual section machine (IS machine)

Eco-Care-Matrix (ECM)

## ABSTRACT

The objects of Life Cycle Assessment (LCA) case studies are often individual components or individual products. Studies focusing on larger industrial manufacturing systems are relatively rare. The purpose of this case study was to assess environmental and cost-related performance of an updated complex manufacturing system for glass containers (i.e. jars, glass bottles, etc.) compared to the predecessor manufacturing system. The objective was also to identify the most relevant drivers for the environmental and the cost profile of the system solution in application context by the means of Life Cycle Assessment, as well as Life Cycle Costing (LCC). The results were then to be displayed in an Eco-Care-Matrix (ECM) in order to quantitatively visualize the improvements when comparing the updated manufacturing system to the previous one and they were to be discussed in terms of (i) ecodesign levers, (ii) efficiency of the LCA process and (iii) their relevance for the speed and cost of the decision-making process. The LCA results of the production stage of the optimized components showed that the largest contributors to the potential environmental impact of the manufacturing system are the motors due to their material composition, number and mass. The use stage was subsequently recognized as the dominant life cycle stage with Global Warming Potential (GWP) as the leading indicator, due to the long service life (20 years) and the corresponding energy consumption. The analysis of a produced glass bottle's GWP showed that it was reduced by about 40% through optimizing the production system. The LCC showed that the modernization pays off after about five years of service life and that the decision for making an investment should not only be based on the required capital expenditure (CAPEX). Rather, operation expenditure (OPEX) should also be considered in order to reflect the savings gained from lower operating costs, which compensate relatively quickly any higher initial expenditure or initial investment. In order to apply Life Cycle Assessment on larger-scale industrial systems, smart and pragmatic LCA modeling approaches have to be developed and adopted, balancing accuracy of results against efficiency in achieving them. An adequate ecological-and-economic assessment tool would reduce the time and effort when making decisions in this context.

© 2016 Elsevier Ltd. All rights reserved.

## 1. Introduction

Today's global challenges involve factors such as population growth and the accompanying increase in consumption of

resources and air pollution, including climate change (UN, 2013). As a result, the awareness for environmental issues is steadily increasing, and customers as well as authorities are becoming more interested in the environmental footprint of products, services and technologies (Chomkhamrri and Pelletier, 2011). Due to customer demands, sector-specific initiatives and legal requirements, the current challenges of the production industry are intensifying, while new challenges are also evolving. Various approaches have been developed in the different sectors; for instance in

\*Corresponding author. Siemens AG, PD EHS, Gleiwitzerstr. 555, 90475 Nuremberg, Germany.

E-mail addresses: [johau@dtu.dk](mailto:johau@dtu.dk), [Johannes.auer@siemens.com](mailto:Johannes.auer@siemens.com) (J. Auer).



transportation (Dobranykyte-Niskota et al., 2007), the automotive industry (Moah and Kanaroglou, 2009) is in need of sustainable electrical cars concepts (Hawkins et al., 2012). In the power generation sector, the increase of renewable power generation technologies calls for improvements in regard to resource utilization (Stoppato, 2006), while sustainability in the manufacturing sector is challenged (Nambiar, 2010) especially by energy consumption as a major cause of environmental impacts and contributions to climate change, and thus is sought to be reduced, as for instance in the pulp and paper industry (Farla et al., 1997), the steel and iron industry (Mao et al., 2013), mining (Linkov et al., 2015) or machining and processing of materials (Denkena et al., 2015).

An example instrument to lower energy consumption are the European Union's Ecodesign Directive (2009/125/EC) and the corresponding measures to establish mandatory ecodesign requirements for energy-related and energy-using products sold inside the European Union. Their objective is to reduce the energy consumption of products, but also to enhance the environmental performance through improved material use and the ability to recycle these products (EC, 2011). Furthermore, environmental footprinting has recently become more popular, as laid down for instance in the EU PEF initiative (Product Environmental Footprints) (EC, 2013). These current approaches focus more or less on the single product and its environmental impact and resource consumption. However, they do not appropriately take into account the performance of the system, which the product is intended to be used in, i.e. they only insufficiently regard the context of target applications. Requirements to and performance of for instance an electric motor may, however, differ widely depending on whether the motor is part of a system, where it is used occasionally vs. a system where it runs constantly.

This leads to a demand for products that are sustainability-optimized in the system design perspective, and consequently, to a demand for practical methods for i) evaluating the environmental footprint in application context, ii) considering at least the most relevant aspects of this in engineering and iii) evaluate if a refurbishing of existing system would make sense. Addressing this background, the aim of the research presented here was to apply the Eco-Care-Matrix (ECM) in a case study of a manufacturing system for glass containers (i.e. bottles, jars, etc.). With the Eco-Care-Matrix, two (product) systems can be compared in terms of their economic and environmental performance (Wegener et al., 2009). The two key elements in the ECM are Life Cycle Assessment (LCA) based on ISO 14040/14044 and a Life Cycle Costing (LCC) approach based on a cost breakdown structure (Hui and Mohammed, 2015). The intention was to derive the most relevant environmental impact issues and their drivers in order to facilitate ecodesign at the system level in the application context. By linking LCA and LCC results in the ECM, different design options can be compared in terms of environmental and economic performance.

The manufacturing system under study is based on individual section machines (IS machines), as used in the container glass industry (Diehm, 2007). Such machines enable a simultaneous and automatic production of container glass. In this case the previously used hydraulic and pneumatic system has been modernized by employing innovative electronic servo drive technology and a motion control concept (Sklostroj, 2015), which is part of the Siemens integrated drive system philosophy (IDS). IDS can be classified as an integrated product service system (IPSS) (Meier et al., 2010). With IPSS, resources can be used more efficiently (Lindahl et al., 2014), especially when these aspects are considered in the system's components development (Bey and McAloone, 2006), as for instance machine availability and productivity may be increased by horizontally integrating the drives, vertically

integrating the whole automation environment and integrating smart services across (Siemens, 2015).

The paper is organized as follows: In Section 2, case study design and applied methods are described and explained. Section 3 then presents the results obtained by applying the methods and Section 4 discusses these in regard to potential generalization, uncertainties and sensitivity. Finally, Section 5 concludes on the results and gives an outlook on future work.

## 2. Methodology

### 2.1. Study design

The aim of this case study was to quantitatively assess the benefits of the modernized manufacturing system when comparing it to the predecessor system in terms of ecological and economic parameters by employing the Eco-Care-Matrix (ECM), based on LCA and LCC. The greatest challenge was expected to be the complexity of the system due to the sheer amount of components involved. Now, starting from a detailed LCA of the servo drive solution, the study was designed to evaluate the most relevant life cycle stage – and in turn, it's most relevant potential impact, as well as the corresponding drivers. Data was then to be captured for comparing the performance of the servo drive solution with the predecessor system in the identified most relevant life cycle stage, both in the environmental as well as in the economic domains, and visualized in the ECM. The study was conducted in 2014/2015 with data captured between 2010 and 2015. Based on foreseeable changes in the technological environment, especially in terms of power generation and the increased contribution of renewable sources, it is assumed that the results will remain valid until 2020 at the latest.

The key methods chosen to address the research topic are LCA (ISO 14040, 2006) and LCC (Woodward, 1997). The environmental and economic benefits of the previous and the updated systems are identified and demonstrated using the ECM. Additionally, the level of resources required for these types of studies are to be discussed and mirrored against the results that have been obtained.

### 2.2. Manufacturing system

Fig. 1 shows the concept of IS machines as used in container glass manufacturing (Trifonova and Ishun'kina, 2007), while Fig. 2 provides a schematic overview of the solution with servo drive components, and Fig. 3 shows the new innovated solution. The predecessor solution, mostly involving pneumatic and hydraulic systems, will be referred to as "System A" and the successor system, using mostly electric servo drives, will be referred to as "System B".

The most critical part of the manufacturing process is the shaping of the glass containers. By using servo drive solutions, the requirements relating to the shaping process, e.g. availability, throughput and robustness, can be met and increased compared to pneumatic or hydraulic solutions. The use of the control system enables several benefits to be obtained for the IS machine, e.g. generation of even and consistent gobs (i.e. liquid glass pieces) by the plunger as well as accurate and dynamic cutting using the shears. This ensures a reliable distribution to all sections of the machine and thermal stability of the whole system, therefore increasing the quality of the end product and the yield, which in turn improves the productivity of the overall system.

Further, the use of smart automation and motion control components, supported by sensors and communication interfaces, allows individual sections or parts of the system to be maintained without putting the whole production on hold (Siemens, 2015).

The fully automated production system consists of a central cabinet module for feeding the material into eight individual

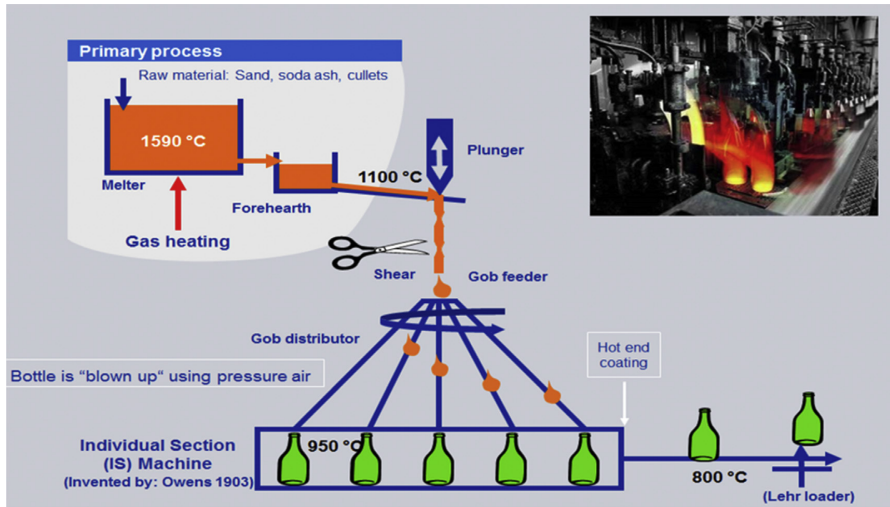

Fig. 1. Concept of individual section (IS) machines used in glass container manufacturing. This basic principle remains the same even after the modernization. Glass smelt gobs are distributed into forms, and compressed air or mechanical components are used to shape the container (hollow). After shaping, the containers are transported by a conveyor belt to cool down in an annealing Lehr (controlled cool down).

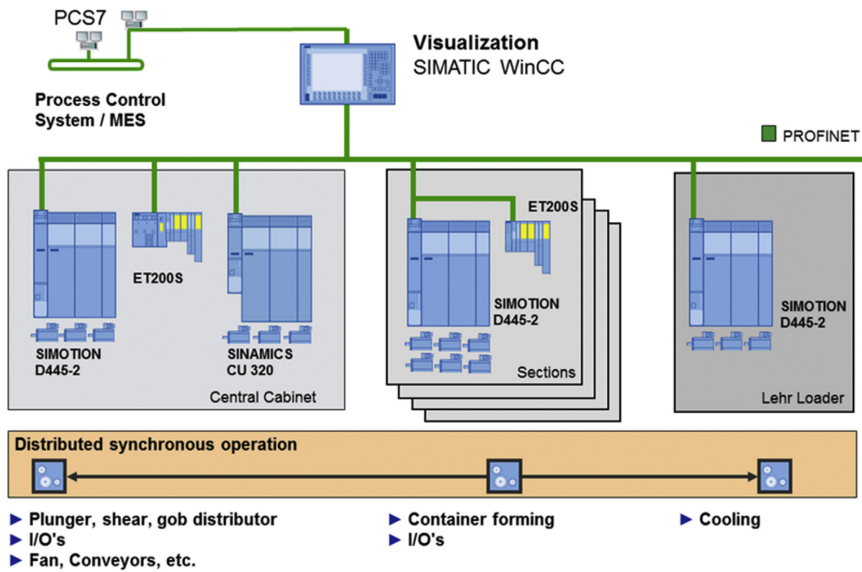

Fig. 2. Overview of the key components of the modernized manufacturing system for glass containers, including process control, visualization, communications, and servo drive systems.

sections for forming, which leads to an output of about one glass container per second. In the predecessor system, actuators and controls were driven by compressed air, whereas in the innovated version, these are driven by highly efficient electric servomotors.

### 2.3. Life Cycle Assessment (LCA)

LCA is a method to quantify the environmental impact of

products, systems and services over the entire life cycle in order to support sustainable development in organizations (Hauschild et al., 2005), as for instance in glass production (Pulselli et al., 2009). The LCA was conducted according to the principles laid down in the international standards ISO 14040 and 14044 (ISO 14040, 2006), as well as the ILCD handbook (EC, 2010) and the recently published product category rules for motor systems, standardized in EN 50598-3 (EN50598-3, 2015). The software GABI6 and the GABI life

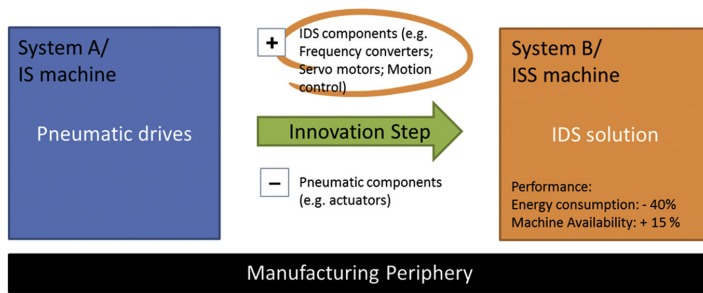

Fig. 3. Visualization of how the system was innovated: Pneumatic components were replaced by servo drive components. The manufacturing periphery stays unchanged.

cycle inventory databases were used for the modeling (Thinkstep, 2015).

### 2.3.1. Goal and scope

The goal of the case study was basically to identify a) the most relevant life cycle stage of the system relating to the environment and the economics and b) the components and environmental impact categories with the highest contributions to the entire system. Additionally, the results were then to be c) broken down to one glass container produced on "System A" and on "System B", respectively. By comparing the previous solution with the innovated one, the expected benefits of the servo drive solution were to be quantitatively evaluated based on the results of the LCA. To achieve this, the perspective of a system refurbishment was taken, which means that the servo drive components were considered as addition to an identical background system (i.e. the manufacturing peripherals), which was identical for the two systems. Since the detailed LCA accounted the modernized IDS components and electric drives in addition to the background system, i.e. as extra burden, vs. the potential benefits resulting from their use, the described comparison can be considered as a worst-case scenario. In real life, the basis for the comparison would be two different systems – the individual section machine, based mainly on pneumatic drive technology and the individual servo section machine, utilizing electric servo drive technology, offered by the OEM. In the case that the increased performance offsets the additional economic and ecological impact, then it could make sense to upgrade existing machines with servo drive components. This is summarized in Table 1.

The functional unit for the study was defined as manufacturing a defined number of glass containers in a certain time frame on a combined system. The number of glass containers manufactured over the system lifetime is 2.88 billion (2.88E+09), based on a throughput of 400 bottles per minute for the servo drive system, by operating 6000 h per annum for 20 years.

The system boundaries for the servo drive components were set according to EN50598-3, corresponding to a cradle-to-grave approach, including the extraction of resources, the manufacturing of the equipment, the use stage (being the production of glass containers) and the final end-of-life stage including recycling and disposal.

### 2.3.2. Life cycle inventory

The life cycle inventory is the basis for the life cycle impact assessment (LCIA) (ISO 14040, 2006). Table 1 gives an overview of the servo drive components used to modernize the production system, and the allocation of the components to certain functions. These components are the basis for the comparative LCA to evaluate the additional burden in the manufacturing stage by enhancing the system with electric servo drives and motion control. The total weight of the components used to modernize the system was about 2.2 tons.

The servo drive components were modelled based on existing Siemens data and aggregated GABI data sets, e.g. for assembly energy, metals and other commodities/materials. As already mentioned above, the basis for the assessment of the use stage was data provided by the OEM supplying the modernized IS machine (System B, IS machine with servo drive components), which state a 40% increase in energy efficiency and a 15% increase in machine availability (Siemens, 2015). To assess the energy consumption of the drive trains in the use stage, the SIZER engineering tool (SIZER, 2015) was used to model the corresponding profile in operation. The efficiency of the servomotors was conservatively set to 90%. The energy consumption of System A was then determined to be 140% of the calculated consumption of System B. The potential environmental impact of the two systems was then calculated using EU27 power mix.

### 2.3.3. Life cycle impact assessment

In the impact assessment, the following impact categories from the CML2001 characterization model of April 2013 as implemented in GABI, were evaluated in detail:

- Eutrophication potential (EP),
- Photochemical ozone creation potential (POCP),
- Global warming potential (GWP) and
- Acidification potential (AP).

The characterization model was chosen due to the fact that data for some of the servo drive components had already been assessed based on this CML model, and in order to aggregate the scores meaningfully, the characterization models have to match. The categories were chosen since they are strongly related to electricity production, since power consumption is known to be a major driver

Table 1  
Overview of the components. Cells with a grey background are included in the scope of the LCA, whereas the disregarded background system is similar in systems A and B.

Scope of LCA	System A	System B
Manufacturing/construction stage	Not considered; no data available	Servo drive components: PLC; frequency converters; servomotors
Use stage	Measurements: Performance data from OEM	Measurements: Performance data from OEM
End-of-life stage	Not considered; no data available	Approximated, based on detailed assessment of key components

when it comes to the environmental impact of the type of equipment under consideration.

#### 2.4. Life Cycle Costing (LCC)

An LCC is a comprehensive decision-making tool for calculating the total costs which are generated over the entire lifetime of products and services (Kádárová et al., 2015). The execution of an LCC enables the potential cost drivers and cost savings of a product or service to be identified over its entire life cycle. By comparing different alternatives, the most cost-effective option can be identified. A variety of methods and approaches has been developed under the umbrella of LCC, due to the heterogeneity and application scenarios of the businesses being analyzed. The common aim of the various LCC approaches is to determine the most cost-effective and thus most competitive solution of a product or service (Woodward, 1997). In this case, the LCC, consisting of CAPEX and OPEX (i.e. capital and operational expenditures, respectively), were derived by using a cost breakdown structure (CBS), taking into consideration the principles laid down by Hui and Mohammed (2015), in order to analyze the cost-benefit ratio in terms of the pay-off period. To estimate the total energy costs of the combined system, a price of € 0.12 for one kWh of electric energy as an average value within the EU was used as basis (Eurostat: EU-28; 2nd half of 2014) based on (EU, 2015).

#### 2.5. Eco-Care-Matrix

The Eco-Care-Matrix (ECM) is used as a decision-making support tool in portfolio management as well as product lifecycle management, including engineering. It plots the ecological impact/benefits over economic performance of a product or system compared against a reference, for instance an outdated or an alternative technology. The application of ECM supports the development of products and services that have been improved from environmental and cost efficiency perspectives. The ECM can therefore be seen as an Eco-efficiency tool, including the challenges associated with the concept of Eco-efficiency, described by Ehrenfeld (2005) and further introduced with applications by (Hupples and Ishikawa, 2007).

The results from LCA and LCC are used as basis to assess the environmental benefits over the economic benefits. While the x-axis represents customer benefit as a change in system costs, the y-axis expresses environmental compatibility of a considered application to the reference point. Environmental benefit can include a combination of any environmental impact. An example for an Eco-Care-Matrix is shown in Fig. 4.

The reference point (e.g. traditional technology) is located at the center of the matrix. While technology/scenario C has higher customer benefits than technologies/scenarios A and B, environmental benefits of technologies/scenarios A and B are higher compared to technology/scenario C. A technology/scenario then can be defined as “green solution”, if it's environmental performance is better than the reference at same level of customer satisfaction (Wegener et al., 2011).

In order to achieve a meaningful application – and therefore robust interpretation of the results of the ECM – it is crucial that the whole framework of the underlying LCA and LCC study is consistent, i.e. uses the same system delimitations, data sources/types, background assumptions, etc.

### 3. Results

#### 3.1. Life Cycle Assessment

##### 3.1.1. Manufacturing

The life cycle impact assessment (LCIA) was performed for each

key component corresponding to the LCA approach described in the previous chapter.

The various components from the five function groups, as shown in Table 2, were clustered into two the clusters electronic devices (VSDs, MC, ACC) and electromechanical devices (motors, S&CG) and handled as laid out in (Hermann et al., 2012). The material composition within the two clusters is more or less the same. The electromechanical components predominantly comprise high grade metals and plastics, and the electronic devices comprise electronic parts that are soldered on printed circuit boards and accommodated in a plastic housing. Table 3 summarizes the results of the LCIA of the manufacturing stage – quantifying eutrophication potential (EP), photochemical oxidation potential (PCOP), acidification potential (AP) and global warming potential (GWP) – for each function group cluster, while Table 4 lists the function groups' potential impacts related to their amount in the system, using the components' weight (within the function group) to build the relation.

Fig. 5 shows the contribution per function group as a percentage for the various impact categories, using the LCIA scores related to the weight of the functionality from Table 4. The contribution of the function groups to each impact category is more or less comparable, but it also shows that the motion control functionality has relatively high LCIA scores related to its weight.

With reference to the GWP, motors made up the largest part of all components with 1.92E+05 kg CO<sub>2</sub>-eqv., which represents 92% for the manufacturing stage (2.09E+05 kg CO<sub>2</sub>-eqv. in total). Frequency converters with 1.21E+04 kg CO<sub>2</sub>-eqv. represented the second highest contribution to the GWP. Evaluating the impacts broken down according to the weight of the components verifies the significance of the motors (or the drive system) in the system context.

To put the result into a broader perspective and to allow a comparison across impact categories, external normalization factors for the EU (25+3) from (Sleeswijk et al., 2008) were applied. The results are shown in Fig. 6.

Looking at the evaluated impact categories, AP, PCOP and GWP are the most relevant impact categories with a similar order of magnitude because they have the highest share to the overall contribution. For a better overview and due to interdependencies between the four impact categories (e.g. all energy-related), results are shown and described in the following in terms of the GWP as leading indicator and are representative for the discussion on the environmental aspects of the combined system. The results of the remaining environmental impact categories supported the statement that motors – respectively the drive system – have the highest environmental impact of the overall system.

##### 3.1.2. Usage

For the assessment of the use stage, the power consumption of all components was screened (i.e. calculated, and not measured) and put in context with the application scenario. The power consumption of 256 components out of 632 was analyzed. Cables and memory cards were excluded along with the power consumption of the drive system, which was separately analyzed in detail. The analysis indicated a mean power consumption of 6 Watts per hour for each component, estimated based on the data obtained from data sheets. This then leads to total power consumption of 10,000 kWh/y for controls, communication and the other automation components. SIZER was now used to model the application and the corresponding power consumption (including losses) for the drive systems in total, based on the parameters mentioned above. A power consumption of about 534,600 kWh/y was obtained. The values were added leading to the total system power

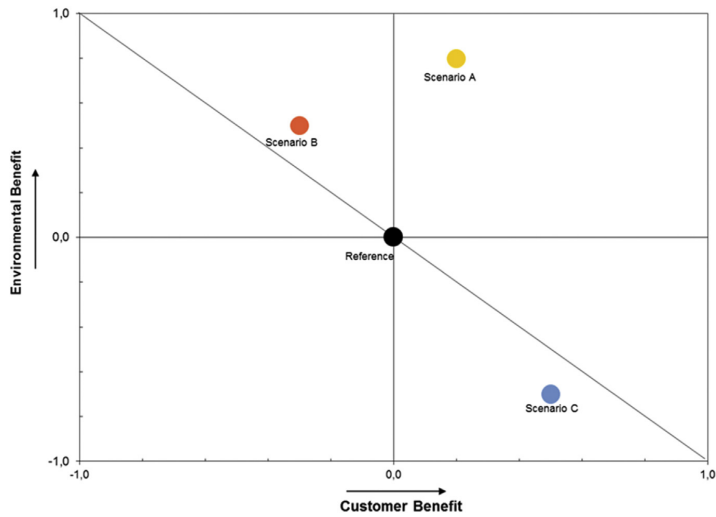

Fig. 4. Example of the Eco-Care-Matrix. Systems are compared to a reference in terms of their economic and environmental performance, displayed as environmental and customer benefit. Basis for the performance comparison is the evaluation of the potential environmental impact based on LCA and economic performance via LCC.

Table 2

Overview of the servo drive components and their function group, needed to modernize the IS machine.

Associated function group: Description	Amount [no. of pieces]	Mass [kg] per function group	Percentage by mass of the whole system
<b>Automation Controls &amp; Communication (ACC);</b> needed to control/automate the whole manufacturing system	292	49.38	2.26
<b>Motion Controls (MC);</b> needed for the control including synchronization of the movement of the drive systems	18	56.25	2.57
<b>Variable Speed Drives (VSD);</b> allow exact control of the torque and speed of the motors	145	672.50	30.77
<b>Motors;</b> transfer electrical energy to mechanical power in order to move parts	103	1385.64	63.39
<b>Switch &amp; Control Gear (S&amp;CG);</b> needed to start, monitor and break operations	74	22.05	1.01
<b>Total</b>	<b>632</b>	<b>2185.82</b>	<b>100</b>

Table 3

LCIA scores in the chosen impact categories aggregated for each function group.

Impact category	Motors	VSDs	MC	ACC	S&CG	Total
EP [kg PO <sub>4</sub> -Eqv.]	6.19E+01	4.10E+00	1.55E+00	7.70E-01	4.00E-01	6.87E+01
PCOP [kg C <sub>2</sub> H <sub>4</sub> -Eqv./kg Mass]	8.24E+01	5.81E+00	1.35E+00	7.50E-01	3.90E-01	9.07E+01
AP [kg SO <sub>2</sub> -Eqv.]	8.18E+02	7.91E+01	2.07E+01	1.29E+01	6.75E+00	9.38E+02
GWP [kg CO <sub>2</sub> -Eqv.]	1.92E+05	1.21E+04	3.15E+03	1.56E+03	8.17E+02	2.09E+05

Table 4

Normalized LCIA scores using the component weight per function group as normalization factor.

Impact category	Motors	VSDs	MC	ACC	S&CG	Total
Weight [kg]	1385	672	56	49	22	2184
EP [kg PO <sub>4</sub> -Eqv./kg Mass]	4.47E-02	6.10E-03	2.77E-02	1.57E-02	1.82E-02	3.15E-02
PCOP [kg C <sub>2</sub> H <sub>4</sub> -Eqv./kg Mass]	5.95E-02	8.65E-03	2.41E-02	1.53E-02	1.77E-02	4.15E-02
GWP [kg CO <sub>2</sub> -Eqv./kg Mass]	5.91E-01	1.18E-01	3.70E-01	2.64E-01	3.07E-01	4.29E-01
AP [kg SO <sub>2</sub> -Eqv./kg Mass]	1.38E+02	1.80E+01	5.62E+01	3.19E+01	3.71E+01	9.58E+01

consumption of 544,600 kWh/y, while the drive systems account for about 98% of the power consumption. By using the EU27 power mix dataset (GABI data), this power consumption corresponds to a GWP of 5.17E+06 kg CO<sub>2</sub>-eqv. over the 20 years of service life.

Additionally, in terms of maintenance, it is assumed that at least the motors would have to be replaced once within the service life of the system, which leads to a total of 5.37E+06 kg CO<sub>2</sub>-eqv. for the use stage.

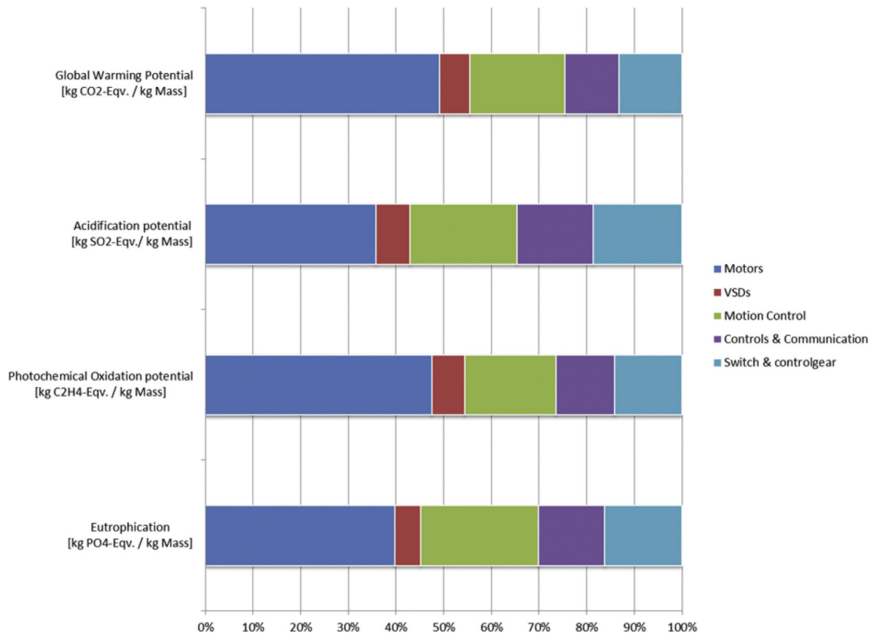

Fig. 5. Graphic showing the contribution per function group to the impact categories as a percentage based on the normalized LCIA scores (weight as normalization factor) from Table 4.

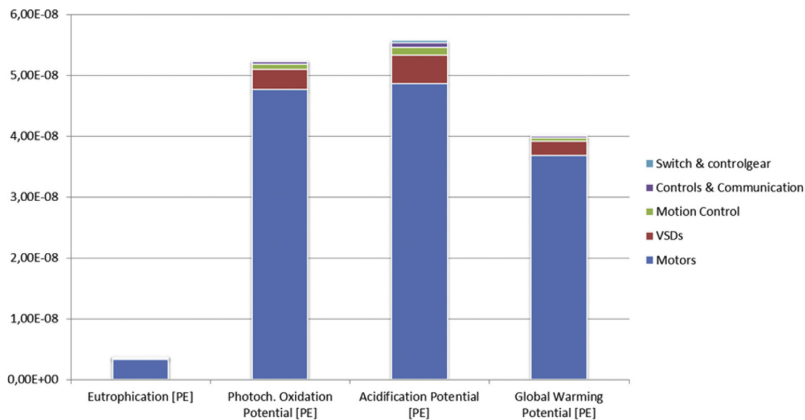

Fig. 6. Graphic showing externally normalized LCIA scores of the manufacturing stage.

### 3.1.3. End of life

The end-of-life stage was assessed in detail for all relevant components, but not considered in this system context because of low significance in the selected impact categories and very few options for the component manufacturer to influence it. For instance, in terms of GWP for motors, the manufacturing of a typical motor accounts for about 0.4% of life time contributions, usage for about 99% and end-of-life for about -0.3% (i.e. a benefit from the end-of-life stage due to recycling etc.). Such expectable benefits from end-of-life have not been considered, due to their low size.

### 3.1.4. Summary of the LCA part

Based on the LCAs of various components used to modernize a glass container manufacturing system, it can be seen that the use stage is by far the most significant life cycle stage in terms of the potential environmental impact. This is due to the drive systems and their energy consumption during use. In terms of absolute GWP numbers, the optimization of the manufacturing system through improved automation, motion control and servo drives, accounts for about 2.09E+05 kg CO<sub>2</sub>-eqv., leading to a reduction of 1.86E+06 kg CO<sub>2</sub>-eqv., which represents a reduction of about 26%. In total, neglecting the potential benefit as a result of the end-of-life

treatment of  $-0.3\%$ , it can be stated that the manufacturing stage of the servo drive components accounts for about 4% and usage for about 96% of the total GWP.

From a different perspective, the higher energy efficiency and the productivity (performance) that were achieved by modernizing the system result in the GWP of the final glass container being reduced by approximately 40%. The ecological payoff period was calculated to be two years, as about 100 tons of CO<sub>2</sub>-eqv. are saved per year as a result of the modernization, accounting for 200 tons of CO<sub>2</sub>-eqv. in manufacturing.

### 3.2. Life cycle costing

For the LCC, costs were derived using a cost breakdown structure, the results of which are summarized in Table 5. It has to be mentioned in this context that in terms of the LCC of the case study, the view taken was that of modernizing an existing system, not directly comparing two alternative options involving “greenfield” plants. The objective was to evaluate the economic benefits in terms of a refurbishment. In the context of “greenfield”, solutions including servo drives are expected to be favorable even with regard to environmental and financial aspects. In addition to the energy costs as well as the investment costs for servo drive components, which were needed for modernization, all other costs were estimated based on experience. The peripherals were omitted from the calculation, assuming that they would be kept in the case of a system modernization or refurbishment. End-of-life treatment was not considered either since component manufacturers can hardly influence the situation in this stage – and therefore no robust data is available. Further, it is assumed that there's no significant difference between the systems, and usually the disassembly and end-of-life treatment has a positive financial impact due to the high quality of materials used in such a system.

The basic principle for estimating the life cycle costs was that

the costs for pneumatic components are about one third of those for the electronic components, but maintenance is usually higher in a manufacturing system dominated by pneumatic and hydraulic actuators. In the study, maintenance costs for System A were assumed to be double those for System B. In order to make a proper comparison with the servo drive system, regarding the installation, it was assumed for the pneumatically driven system that at least the actuators would have to be replaced by servo drive components when modernizing. For an operating time of 20 years, it was assumed that at least some components, e.g. the motors and the pneumatic actuators, would have to be exchanged after 10 years of operation. The ZVEI LCC analysis tool (ZVEI, 2015) was populated based on the CBS and depreciation for the investment (10% of the investment for 10 years) was taken into account. A comparison of the LCC of the two systems over the life cycle stages is shown in Fig. 7 and the corresponding cash value, based on 20 years of service life is shown in Fig. 8.

Based on this LCC, the modernized System B performs about 19% better than the previous system, resulting in savings of about 450,000 € over 20 years of lifetime. Taking the cash value of the energy costs into account, System B outperformed system A by 29%. The payback time for the modernization was calculated to be around 5.34 years.

### 3.3. Eco-Care-Matrix

The ECM for the two systems in Fig. 9 shows the environmental and economic improvements of the system when using servo drive components. The reference, System A, located at the center of the matrix, is responsible for energy costs of more than 1.5 million € and the discharge of more than 7243 tons CO<sub>2</sub>-eqv. over the operating time of 20 years. The benefit of the enhanced system with servo drive components (System B), is represented by scenario 1. Concerning environmental benefits in terms of GWP, the

**Table 5**  
Summarized cost allocation derived from a cost breakdown structure for life cycle costing.

Cost allocation	System A: IS with pneumatic/hydraulic actuators		System B: IS with IDS components	
	Parameter [k€]	Remark	Parameter [k€]	Remark
Machines	100	Exchange of pneumatic/hydraulic actuators	300	Exchange of pneumatic/hydraulic actuators with servo motors
Installation	10	Once per service life, 10% of Investment	30	Once per service life, 10% of investment
Maintenance	40	20 k€/a	20	10 k€/a
Spare parts	50	Exchange of pneumatic cylinders	100	Exchange of motors
Energy (electric power, kWh)	1800	$1.50E+07 \text{ kWh} * 0.12 \text{ €/kWh}$	1284	$1.07E+07 \text{ kWh} * 0.12 \text{ €/kWh}$
Total	2360		1910	

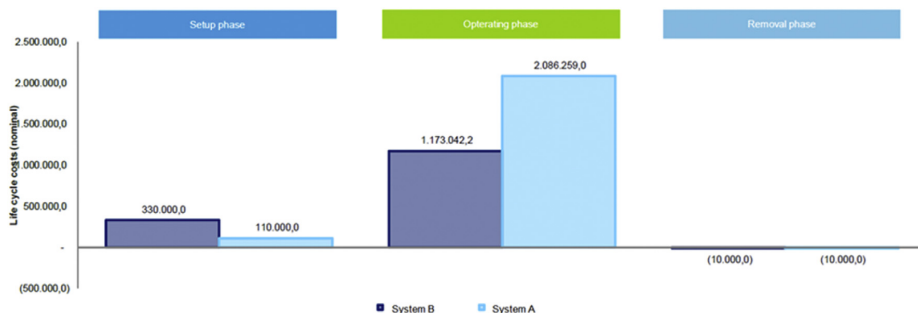

Fig. 7. Comparison of life cycle costs over the individual stages at harmonized project duration.

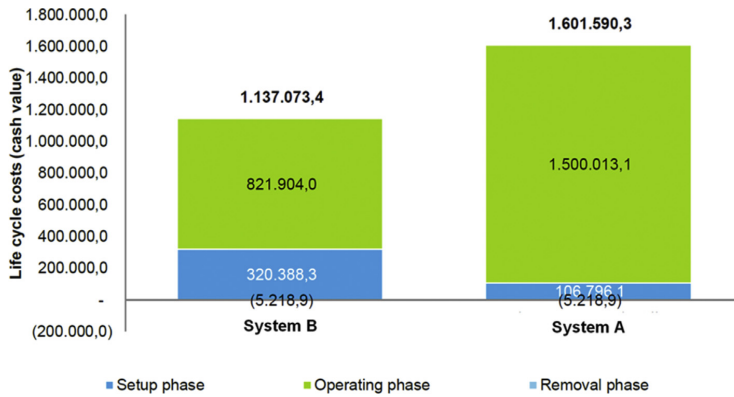

Fig. 8. Cash value of life cycle costs at harmonized project duration.

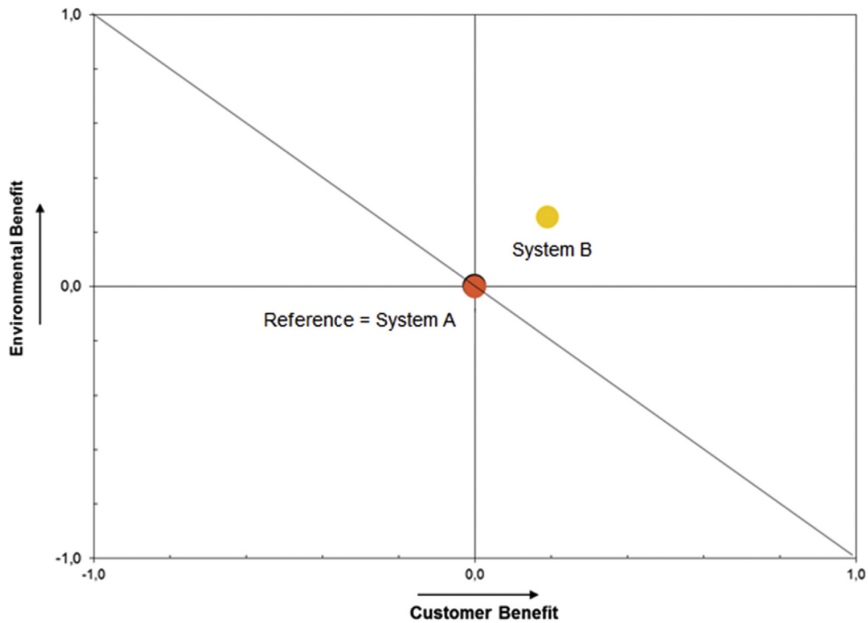

Fig. 9. Eco-Care-Matrix comparison of the two systems. System A is the reference, system B, enhanced with servo drive components, provides economic and environmental benefit.

introduction of motion control and servo drives lead to an “improvement” of about 26% (a reduction of about 1.9 million kg CO<sub>2</sub>-eqv. in absolute terms), while the customer benefit increases by 19% (just taking into account the cost savings).

Linking these results to the output of the manufacturing system, the carbon footprint of the container glass bottles produced on System B is reduced by about 40% compared to System A.

**4. Discussion**

It first has to be stated that this case study was carried out in an application-specific context (i.e. a specific technology) and in a European setting. The results will be different depending on the

particular region and application – and will especially depend on the power grid mix and the associated environmental impact. On the application side, in a less dynamic production flow, i.e. one with longer holding intervals, the differences between pneumatic and servo solutions can be expected to be less, as (Hirzel et al., 2014) pointed out when comparing pneumatic to electric actuators.

In terms of the financial benefits of the investment regarding modernization, it has to be emphasized that some parameters in the study were estimated based on the assumption that the manufacturing peripherals were identical. For instance, instead of modernizing a manufacturing system (one of the scenarios in this case study), if a completely new manufacturing system without compressed air is built, all of the auxiliary equipment required to



provide compressed air can be reduced. This results in even higher savings. On the other hand, if there is a very effective compressed air system in place and different process settings, savings might be lower and the payback time for the investment will be longer. Additionally, the economic framework of the company will significantly influence the payback time of the investment, for instance individual interest rates, depreciation practices and discounts negotiated for the investment, etc. Finally, the current and future market situation will also have an impact here, especially how electricity prices and inflation rates will develop. Hence, it can be said that the LCC approach was too generalized to obtain an impression about investing in a refurbishment, because in reality, the specific financial pay-off will depend on the very individual situation of the particular company.

The results of the environmental performance evaluation based on life cycle assessment clearly showed the high significance of the use stage. Therefore, the chosen power mix and levers for increasing energy efficiency have a high influence on the potential environmental impact. In the current European average power mix, coal, oil, and natural gas still play a big role as primary energy sources and contribute to global warming, acidification and eutrophication being the most relevant impact categories. This will change due to an increasing share of renewables providing electric power and consequently declining climate relevant emissions from the power mix. Hence, other indicators/impact categories might be more relevant in the future, as well as other aspects of ecodesign (besides energy efficiency) tackling these impacts. Therefore, more impact categories than the energy-related ones used in this study should be taken into account in further studies, like for instance resource depletion and toxicity. In that context it has to be mentioned too that the results should then also be validated by applying different characterization models in order to take latest scientific developments into account, e.g. within toxicity-related impact categories.

The performance evaluation, as key parameter for the above-mentioned results, has been carried out by the system provider and was based on measurements in a defined application set-up, coming to an average in energy savings of 40% when comparing the two systems. There was no detailed data available concerning the individual process steps and the associated operations. Therefore, the results shouldn't be transferred to any other, principally comparable manufacturing system or generally on the discussion of efficiency of pneumatic vs electric drives. In this context it has to be assumed that the relevant parameters, e.g. cycle time and power demand, may have been favorable for electric drives, but again these aspects were not in the scope of this case study.

## 5. Conclusions and further work

The analysis of the complete modernized manufacturing system for container glass bottle production showed that the largest contribution to the environmental impact and to the economic costs is related to the energy requirements during the use stage. As a consequence, the highest opportunities for reducing potential environmental impact and costs, can be realized by upgrading the system to include motion control and servo drives. The underlying LCA of the manufacturing system itself was a rather extensive case study, taking into account more than 600 components, enabling to allocate the environmental impacts, as well as the benefits to certain functionalities of the system. It can be concluded that any intelligence (controls, communication) which may be added into a comparable manufacturing system, that improves (energy) efficiency and throughput, will pay off in terms of cost savings and the reduction of (potential) environmental impact. In terms of the cost-benefit evaluation it can be concluded that even a refurbishment of

an existing system can be a viable option for improving performance. In terms of environmental aspects, manufacturing, as well as the end-of-life stage can almost be neglected in an industrial context with service lives from 10 to 20 (or even 30) years and the corresponding high quality requirements, realized through high quality materials, service and repairability. Similar conclusions were drawn in other case studies in different application contexts, e.g. pumps (Smith, 2011) and compressors (Siemens, 2014), and today even reflected in a corresponding standard for drive systems (EN50598-1, 2015) so at this point the importance of the message – “carefully consider the application setup and scenario” – has to be stressed to avoid counterproductive sub-optimizations at the component level in the system context or micro optimization.

Therefore, it can be concluded that when using LCA as a method for ecodesign at the system level or in the context of the product environmental footprint (EC, 2013), valid simplifications are necessary for the assessment of these life cycle stages. To quantify it: Out of the 632 components and devices used to modernize the system, approximately 300 would have to be assessed in detail (full scale LCA); Using 52 h as an average mean time for conducting the LCA based on (Auer et al., 2014) this leads to 15,600 working hours for LCA experts to carry out the various studies; using 60 € as hourly wages, this leads to costs of 936,000 € for carrying out the LCA for the manufacturing system. Surely this is “overkill” for the methodology in this context and considerable thought has to be given regarding its application.

For companies using LCA to support ecodesign and to support sustainability messages, the key recommendation by the authors is to (i) adapt the methodology to the system perspective and to (ii) be able to map the applications in this context. For instance, the enhancement of system engineering tools with relevant environmental indicators would be an option to promote ecodesign on a larger scale than just providing data for up to 30 different environmental impact categories as is the case in some environmental product declarations.

Concerning the future work, the applied eco-efficiency analysis tool, the ECM, is meant to be further developed for optimizing the IPSS of Siemens, the Integrated Drive System, in regard to the included product and service portfolio. The further development of the method should aim at combining technical, economic and environmental aspects in regard to the targeted application and thus to further optimize the offering, for instance by identifying and evaluating additional portfolio elements or further integration needs. Based on the needs of an application, a solution can be derived from the existing system components. By applying LCC and LCA (as underlying methods of ECM) drivers for cost and environmental impacts (e.g. in investment or operating costs, energy consumption related emissions or resource consumption) can be identified. Based on this analysis e.g. an additional portfolio element could then be identified and the improvement evaluated again by LCC and LCA using approximations and/or reference data. The ECM could then be used to display the options in a comparative view with the initial solution as reference point. This would even be more interesting if more than two options should be compared. Here research could address the combination of the ECM with multi-attribute decision analysis. In any case this requires switching from a retrospective, as in this case study, to a foresight application of the eco-efficiency tool. Both methodologies underlying the ECM, LCA and LCC, are capable of handling scenarios, which is a core requirement in that context. However, especially for the LCA – or more generally, for the evaluation of the environmental aspects – simplifications or rather smart approaches are necessary, balancing efficiency with accuracy, to be able to build a consistent and flexible model of the IPSS.

In regard to the evaluation of the environmental performance of



**JP-II: COMPARATIVE LIFE CYCLE ASSESSMENT OF  
ELECTRIC MOTORS WITH DIFFERENT EFFICIENCY  
CLASSES: A DEEP DIVE INTO THE TRADE-OFFS  
BETWEEN THE LIFE CYCLE STAGES IN ECODESIGN  
CONTEXT**

MANUSCRIPT SUBMITTED FOR PUBLICATION IN THE INTERNATIONAL  
JOURNAL OF LCA

# Comparative Life Cycle Assessment of electric motors with different efficiency classes: A deep dive into the trade-offs between the life cycle stages in Ecodesign context

Johannes Auer,<sup>a,b,\*</sup> Anna Meincke,<sup>c</sup>

<sup>a</sup> Department for Environment, Health & Safety, Process Industries & Drives Division, Siemens AG, 90475 Nuremberg, Germany

<sup>b</sup> Department of Management Engineering, Division for Quantitative Sustainability Assessment, Technical University of Denmark, 2800 Kgs. Lyngby, Denmark

<sup>c</sup> Department of Environmental and Climate Affairs, Sustainability, thyssenkrupp Steel Europe AG, 47166 Duisburg, Germany

## Abstract

*Purpose:* Current ecodesign instruments usually focus on improving single life cycle stages, like the energy efficiency classes for motors put on the European market, which focus on the use stage. Resulting trade-offs between the life cycle stages are however often not integrated properly, like for instance trade-offs between manufacturing stage and use stage. Goal of this study was to evaluate the trade-offs between the additional efforts of producing energy-efficient motors (achieved e.g. via different materials for certain components) and the advantages gained from the improved efficiency in operation.

*Methods:* For this case study, Life Cycle Assessment methodology according to ISO 14040/44 was applied for the whole life cycle (cradle to grave) of three electric motors, each from a different efficiency class, and one serving as baseline. The motors under study have the following specifications in common: Asynchronous technology, 110 kW nominal power, cast iron series, 4-poles. To evaluate the use stage, two different operational profiles were studied for 20 years service life.

*Results and discussion:* The results clearly indicated the dominance of the use stage in the motors' life cycles and that an increase in efficiency pays off environmentally within the first month of operation in the applied load-time profiles. The dominating environmental impact categories, like ionizing radiation and global warming potential, relate to the consumption of electricity. The study results indicated also that the increase of the analyzed motors' efficiency encompasses trade-offs between the stages materials, manufacturing and end-of-life versus the use stage in regard to toxicity and (metal) resource depletion aspects; i.e. a burden-shifting between energy-related impacts and the toxicity- and resource depletion-related impacts.

*Conclusions:* In the analyzed study set-ups, including the modeled energy generation scenarios for Europe in 2050, an environmental break-even is achieved in less than a month in all impact categories except for human toxicity. Thus, the further improvement of energy efficiency of drive systems is and will stay a central ecodesign lever. However, toxicity and resource depletion trade-offs should be considered carefully within decision support and decision-making, and further research on related characterization models is necessary. Further, it is concluded that the load-time profile as well as the motors' service life have a high influence, and therefore designing drive systems in context with the application seems to be an important approach to facilitate ecodesign.

**Keywords:** Life Cycle Assessment, electric motors, ecodesign, energy efficiency.

## 1 Introduction

Global warming has to be limited to well below 2°C compared to the average temperature in pre-industrial times to prevent the most severe impacts of climate change and possibly catastrophic

changes in the global environment. This was agreed by almost all countries worldwide in 1992 under the United Nations Framework Convention on Climate Change (UNFCCC) and just recently tightened through the agreement in Paris at the end of 2015 [COP21]. To achieve this, the world must stop the increase in greenhouse gas emissions by 2020 and reduce them by 60% by 2050 compared with 2010 [COM 2010]. The 2020 climate and energy package is a set of binding legislation to ensure the EU meets its climate and energy targets for the year 2020. The targets were set by EU leaders in 2007 and enacted in legislation in 2009. They are also headline targets of the Europe 2020 strategy for smart, sustainable and inclusive growth [EC 2020].

As an accompanying legislative act, the “Energy using products directive” as well as its successor the “Energy-related products directive”, referred to as Ecodesign Directive, were issued [EU 2009]. Resulting from this, a first study concerning the energy usage of branches and associated technologies was conducted and work plans [COM 2008; SWD 2012], prioritizing products under the scope of the directive, were issued. Electric motors use almost 50% of the electricity in Europe in applications like elevators, cranes and cooling systems. More efficient motors could save Europe then around 135 TWh of electricity by 2020 – equivalent to the annual electricity consumption of Sweden – and correspondingly 60 million tons of CO<sub>2</sub> emissions [EC 2014]. Therefore electric motors were addressed within the first work plan and resulting from the conducted preparatory study was a product specific regulation, regulating the efficiency levels of motors to be put on the market of EEA [EU, 2014]. Then in 2015 the European Commission issued the Circular Economy Package (CEP) [EC 2015], following the European Resource Efficiency Roadmap [EC, 2011a; EC, 2011b], which adds another dimension to the subject by aiming at improving resource and material utilization by various measures, including among others a standardization request for material efficiency standards [EC 2015b]. A consequence

might be a dilemma of balancing energy efficiency for the sake of mitigating climate change and associated risks versus material (or resource) efficiency mitigating resource depletion and economic risks resulting from scarcities. Since up to now there are, besides the preparatory studies associated with ErP directive (e.g. [Almeida 2008], [Almeida 2014]) applying the so-called MEEuP [VHK 2005] and MEErP [MEERP 2015] Methodology for evaluating ecodesign levers, there are no detailed assessments of electric motors available, the present study aims at assessing the trade-offs between the additional efforts at the materials and manufacturing stages needed to achieve the higher efficiency levels in the use stage by the means of the Life Cycle Assessment (LCA) methodology and to then evaluate and discuss environmental hotspots. For that, 3 motors of a defined type – 4 poles, cast iron series – but with different efficiency levels (IE2, IE3 and IE4) will be assessed.

The paper is structured as follows: Chapter 2, the methods section, describes the applied method LCA and its framework; Chapter 3, describes the Life Cycle Inventory (LCI) and the results of Life Cycle Impact Assessment (LCIA) per life cycle stage, as well as summarized them in a comparative view; Chapter 4 then interprets and discusses the results of the LCIA and follows up the findings in terms of sensitivity checks; Chapter 5 finally concludes on the results of the case study.

## **2 Method: Life Cycle Assessment**

The underlying methodology is the life cycle assessment (LCA) methodology as laid out in [ISO 14040, ISO 14044], following the principles described in the “ILCD handbook” [ILCD 2010], using the impact indicators and characterization models as recommended by the EC JRC for usage in EU policy context [ILCD 2011]. Additionally the so called product category rules (PCR) for motor systems were taken into account, as described in [EN50598-3]. For the

modelling GABI6 and the GABI life cycle inventory database supplied by thinkstep AG were used.

### *2.1 Goal & Scope*

The study aims to compare the potential environmental impacts of motors of one product family (same technology, same product type, same power rating) with different efficiency classes over the whole life cycle in the current European context of the EcoDesign Directive and the Circular Economy Package. The goal is to evaluate the trade-off between the materials & manufacturing stage (more copper, higher grade electrical steel etc.) and usage (less power consumption through higher efficiency) in detail and to additionally conduct a hot spot analysis, which results may be used internal in product design.

### *2.2 Assumptions & Limitations*

Important part of a LCA case study report is to state taken assumptions and identified limitations that have to be considered when interpreting and conclusion on the results. In the context of this case study the following should be taken into account:

- (1) Bill of Materials were only available for the complete motors and not for their components (part level), therefore certain limitations apply concerning manufacturing steps for these components. On the other hand it has to be considered that for most of the materials typical, appropriate manufacturing steps (semi-finished goods) can be assigned. In this context, the assignment of the generic (background) datasets to the materials should also be recognized as of high importance to robust results. Anyhow these limitations will apply to all assessed products in the same way. Transportation of the materials to the factory were not considered in detail due to a lack of robust, precise data and a rather complex supply chain from the ore to the semi-finished goods and components needed for assembly. It was assumed to be not significant, based on internal ecodesign and LCA case studies and anyhow a lot of transport related data is already included in

the applied background datasets. The distribution stage of the final product was considered to exclude it from having significant contribution to environmental impacts.

- (2) Energy usage for the assembly had to be allocated based on working hours, which means that we allocated a mean energy consumption per production working hour, based on the metering of primary and secondary energy meters of the factory for one year, along the production working hours needed for a motor of this type. Based on comparison of certain production steps with literature and generic data sets, it is known to have a high level of uncertainty due to a rather complex facility infrastructure with a lot of consumers not directly linked to the production of the products. The working hours for assembly were assumed to be independent of the efficiency class of the motor (not major change of technology), whereas higher efforts, e.g. energy, needed for the utilization of more material (or higher grade material) were included in the secondary data, the datasets of the materials and parts assigned. This assumptions and limitations again will affect all motors in the same manner and hence not affect the comparative assessment. The applied generic usage scenarios were representative but not application specific; therefore the results may vary in other scenarios including different load-time profiles as well as different regional specifics like the electricity mix. The chosen scenarios are intended to give an idea about the variability of the use stage and its influence on the associated environmental impacts.
- (3) For the end-of-life stage, which was assumed to take place in Europe due to usage in Europe, a generic end-of-life-scenario was derived based on [Kasper et al., 2015] and [IEC/TR 62635]. It is assumed that the main parts of the motor will be disassembled, then shredded, followed by material separation by respective technologies using physical properties (magnetic, density) routing metals into recycling processes and plastics to energy recovery process. Others were assumed to be finally be landfilled. Respective recycling and recovery quotes were drawn from the generic datasets for end-of-life treatment.

This has to be considered when concluding on the results. The case study will only display results according to this specific set-up and can't be generalized to all applications on global scale, especially concerning the impacts associated with electricity generation and the contemporary grid mixes in the various regions in the world.



### *2.3 Function, functional unit and reference flow*

Main purpose of an electrical motor is to convert electrical power into mechanical power for various applications, e.g. conveyor belts, pumps, fans. The energy conversion can be realized by different types of technology, for instance asynchronous or synchronous to the net frequency and corresponding product designs. Usually each of these technologies does have its advantages and disadvantages in context to the application. One key point in any case is the efficiency of this energy conversion. The products under study are Siemens motors of type Simotics SD basic, cast iron series, 4-poles, 50 Hz, self-ventilated with the international efficiency (IE) classes IE2, IE3, IE4, whereas the efficiency classes are defined in [IEC 60034-30-1].

The functional unit (FU) was defined as the provision of mechanical power in an applied usage scenario (operation profile, load-time profile) by electrical motors with 110 kW nominal power at 365 days a year in 20 years of service life. For the two applied usage scenarios, which are described in detail in chapter 3.2, the reference FU, used in the comparative assessment and derived from the corresponding output (mechanical power) of the motor with efficiency class IE2, was defined as:

- (1) Scenario A): High duty - Provision of 15,658,500 kW nominal power;
- (2) Scenario B): Low duty - Provision of 8,431,500 kW nominal power.

The reference flow was determined as [kg] of electrical motor (baseline IE2-motor: 707 kg, range up to 744 kg for IE4-motor).

### *2.4 System boundaries and cut-off criteria*

The assessment includes all life cycle stages from cradle to grave. The system boundaries were defined according to EN50598-3, also taking into account the defined parameters, like for end-

of-life. The manufacturing stage includes all processes associated with producing the motor, from the upstream processes such as mining of metal ores and extraction of crude oil, to the final assembly of the motor, including forming processes for the semi-finished goods, like stamping, bending, die casting and impregnation / insulation. Figure 1 schematically displays the set system boundaries including the background and foreground data.

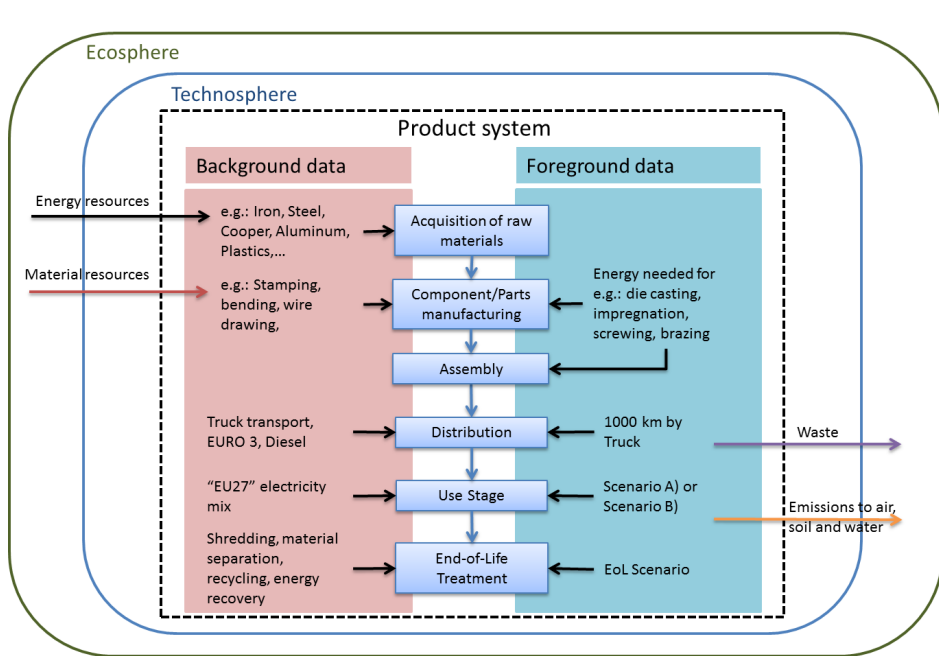

Figure 1: Graphically display of the system boundaries of the LCA case study to evaluate the environmental performance and potential trade-offs between motors with different efficiency classes in two different usage scenarios.

For final assembly (e.g. screwing), die casting and impregnation, the energy consumption has been allocated to the motor based on the factory's reported data from 2011, see subchapter 2.2. For the other processes generic data (e.g. punching, bending, wire drawing, coating...), as available in the corresponding tool and database, were used. Distribution has been considered as

1000 km truck transport within Europe. Not considered were the transport of materials to production site, initial sample tests, all activities concerning the superstructure (building of and maintenance of the production facilities, tools and machines), and resources for R&D, planning and sales. No further cut-off criteria were applied.

### *2.5 LCI modelling framework*

Based on the defined decision context, the modelling framework of this study is set to the attributional principle, depicting the existing value chain, i.e. use the current state of the art data of the modelled system. For instance the German electricity grid mix is used for the motor production, since it's build in Germany, the EU27 electricity was used for the assessment of the use stage, as well as end of life processing because the location of the application is assumed to be "somewhere in Europe" (see also subchapter 2.1). Multifunctionality of processes is solved using allocation based on physical properties (weight) and economic data (working hours). In this context it shall be considered that the systems basically do not have secondary functions to providing mechanical power and any occurring problems of multifunctionality of the product systems in manufacturing and end-of-life are handled in the same way.

### *2.6 Data quality requirements*

Generic data was checked to fulfil the "ILCD requirements" on data quality (or in other words "ILCD compliance"). In regards to managing uncertainty, no specific limit of the variance of the inventory data was set. In this context it has to be considered that the major goal is a non-assertive comparative analysis of electrical motors with different IE-classes, hence in terms of data quality, the data differentiating the systems (Material composition and energy consumption at the use stage) is mainly important and was therefore directly drawn out of technical data

systems and product documentation. Other uncertainties, choices and assumptions will apply to all systems under study in a similar way and can therefore be neglected.

#### *2.6.1 Technological representativeness*

The technology of the electrical motors, the material composition of the product respectively, and their production processes is based on Siemens technology. It's supposed to be quite similar to the technologies used by other motor manufactures in Europe and therefore representative of the current state of the art.

#### *2.6.2 Geographical representativeness*

As explained in the introduction, the goal of the study was to reflect the European situation; hence the use stage should represent the European average (e.g. electricity mix). Data for manufacturing (assembly, parts manufacturing) should reflect the German situation since the motors under study, corresponding to the applied product standards are intended for applications in the European Economy Area (EEA), are produced in Germany. Concerning the materials stage, global data sets should be applied since the associated supply chain is not defined in regard to geographic origin.

#### *2.6.3 Temporal representativeness*

This kind of electrical motors with 110 kW is usually utilized, depending to some extent on the influence of application environment (e.g. dust, corrosive atmosphere, mechanical stress), for about 20 years and rated as investment goods. The innovation cycle is around 7 – 10 years, whereas the development of the next generation will take approximately about 4 years, depending a lot on the needed certifications, tests and approbations for the usage. In the last years (last product redesigns) there has been no major change in the manufacturing processes or

product technologies, therefore data from 2010 to 2015 can be seen as being temporal representative for the case study. Given the current development of the underlying data, the case study can be seen as valid for up to 5 years. After that period the results have to be reviewed in context to technological changes, especially concerning the environmental impacts associated with the electricity generation and distribution, which – due to the shift to renewable energy sources – will likely change to lower scores.

### *2.7 Life cycle impact assessment methods*

For the life cycle impact assessment (LCIA) the midpoint characterization methods recommended by the European Commission's Joint Research Center (JRC), Institute for Environment and Sustainability, published as part of the ILCD handbook are used [ILCD 2011]. These are also used in the context of the Product Environmental Footprint (PEF) initiative by the European Commission and therefore currently very relevant to industry, due to a potential application in policies. Internal and external normalization was applied to support the interpretation of the LCIA results, by relating the LCIA scores to defined bases. Consequentially for external normalization the Normalization Factors (NF) per Person (PE = Person Equivalents) as defined in the PEF guide for the products are used, which relate the LCIA results to the European domestic inventory in 2010. Per person normalization factors (Person Equivalents) have been calculated using Eurostat data on EU 27 population in 2010. Characterization methods and NF are listed in Table 1 below [EC 2016]. Further following the PEF guide, weighting currently is applied using the weighting factor 1 for all impact categories.

Table 1: Characterization methods applied in the study, as recommended by ILCD for life cycle assessments in European policy context. The normalization factors (NF) as Person Equivalents (PE) are taken from the PEF guide for pilot studies [PEF 2016].

Abbreviation	Characterization methods and models	Unit	Normalisation Factor (NF)
TE	Terrestrial eutrophication, Accumulated Exceedance model	molc N eq	1.76E+02
FE	Freshwater eutrophication, EUTREND Modell, ReCiPe	kg P eq	1.48E+00
ME	Marine eutrophication, EUTREND Modell, ReCiPe	kg N eq	1.69E+01
PM	Particulate matter, RiskPoll	kg PM2.5 eq	3.80E+00
PCOF	Photochemical ozone formation, LOTOS-EUROS Modell, ReCiPe	kg NMVOC eq	3.17E+01
RD, w	Total freshwater consumption / Resource Depletion – water, UBP 2006	UBP	8.14E+01
HT, c	Human toxicity, cancer effects, USEtox	CTUh	3.69E-05
HT, nc	Human toxicity, non-cancer effects, USEtox	CTUh	5.33E-04
IR	Ionizing Radiation – human health effects, ReCiPe	kg U235 eq	1.13E+03
GWP	IPCC global warming, w biogenetic CO <sub>2</sub>	kg CO <sub>2</sub> eq.	9.22E+03
ET, f	Ecotoxicity – aquatic, freshwater, USEtox	CTUe	8.74E+03
OD	Ozone depletion, WMO Modell, ReCiPe	kg CFC-11 eq	2.16E-02
RD, f+m	Resource depletion - fossil and mineral, CML 2002	kg Sb eq.	1.01E-01
A	Acidification, Accumulated Exceedance model	mol H+ eq	4.73E+01

It should be noted that, corresponding to the reference [ILCD 2011], certain characterization methods – even though being recommended – still are rated with Level III for data quality and should therefore be considered with caution in interpretation. The same caution should also be taken when drawing conclusions from normalized LCIA scores. Normalization is needed to enable the comparison across impact categories, but external normalization is questionable as

potential normalization bases still lack political and scientific consensus concerning the so-called areas of protection (environment, resources, toxicity) [Bjørn and Hauschild, 2015].

### **3 Life Cycle Inventory**

The following chapter describes the key aspects of each life cycle stage in the life cycle inventory phase of the LCA.

#### *3.1 Materials and manufacturing stage*

Key aspect to potential environmental and toxicity impacts of electrical motors, being electromechanical products, is the material composition. Processes for extracting ore out of earth and making “usable”, raw material out of it, are the drivers of environmental effects like acidification or global warming, as well as related effects like resource depletion [Hermann et al., 2012]. For this case study the material composition of the parts of an electrical motor were summarized to certain material groups, resulting in the material composition of the motors of different international efficiency (IE) classes as displayed in Table 2 below. The IE classes are defined in IEC 60034-30-1:2014, from IE2 (high efficiency) to IE4 (super premium efficiency). The table also includes assigned generic processes from the Gabi database.

Table 2: Material composition of the motors with different IE classes. The IE2-motor is the reference for the percentages displaying the increase for certain material groups when the efficiency is increased.

Material group (assigned generic treatment processes)	IE2	IE3	IE4
Electric sheets (stamping)	271 kg	10%	10%
Cast Iron (die casting)	271 kg	0%	0%
Copper (wire drawing)	69 kg	4%	10%
Other Steel (stamping and bending)	64 kg	0%	0%
Packaging Material (wooden pallet production)	24 kg	0%	0%
Aluminum (extruding)	19 kg	5%	5%
Impregnation Resin	5 kg	20%	20%
Others: Other materials with mass below 5 kg and no difference between the IE classes:  Plastics (injection molding), Insulation, Paint (painting), Rubber, Brass (stamping and bending), Solder (brazing) & Grease	9,8 kg	0%	0%

Figure 2 displays the material fractions that have been increased in quantity to reach the higher efficiency levels accordingly. These material groups then have been matched to a corresponding, most representative LCI processes in GABI, reflecting the inputs, like crude oil or copper ore, and outputs, like CO<sub>2</sub>-emissions or metal scrap, of this manufacturing step.



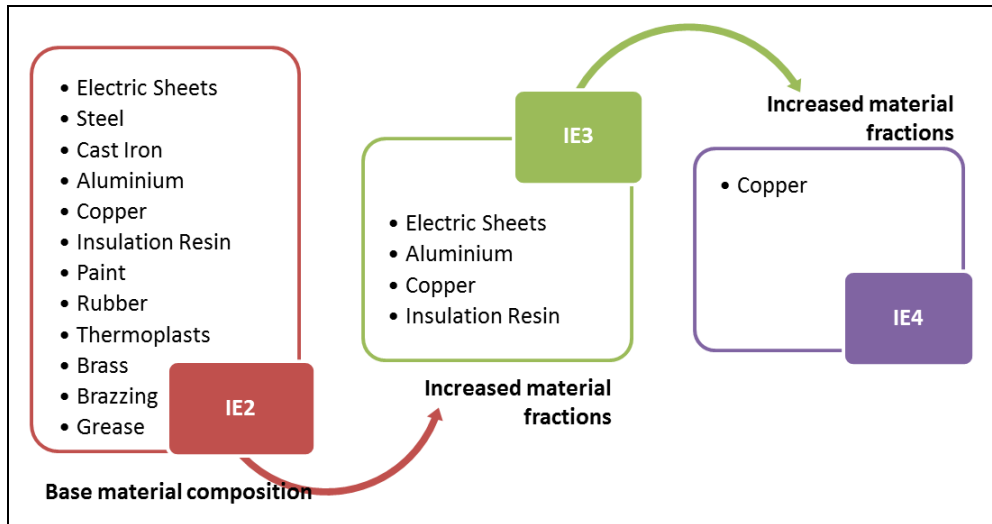

Figure 2: Display of material fractions increased, from the base material composition of an international efficiency class 2 (IE2, high efficiency) motor, to achieve higher efficiency levels: International efficiency class 3 (premium efficiency) and 4 (super premium efficiency) as defined in IEC 60034-1-30. No material fractions decrease in this regard.

After this, the most representative machining or treatment process, like wire drawing or die casting (see also Table 2), is added to the material group to reflect the aspects of the finishing processes, including energy consumption and typical material losses as available in the generic data sets. To finally finish the model of motor manufacturing, the last step added is the final assembly. The energy consumption for assembly, including varnishing/impregnation was approximated based on an allocation of the 2011 annual energy consumption by working hours. Parts or material transport is only included as far as reflected in the generic data.

Distribution of the final product to the usage location is considered by transportation by truck (consuming diesel) and a distance of 1000 km.

### 3.2 *Use stage*

The use stage is known in drives for being the (by far) most relevant, because of the purpose of the functionality of transferring electrical energy into mechanical power. Use stage in drives, including motors, is characterized by an operating profile, defined by the time fraction the component is operating at specific operating points [EN 50598-1, EN50598-2]. These operating points of motors are characterized by the motor's load at a certain speed in percent of their nominal values. Further the motor's efficiency (or rather the losses) depends on these values (load, speed) and is therefore specific for the operating points. The operating or load-time profile itself puts them then into context to a defined amount of time, e.g. the time fraction the motor runs at the specific operating point in the applied use scenario [Auer and Weis, 2014]. Operating profiles, in principle displayed in Figure 3 can roughly be distinguished into two types:

- Fixed speed operation – Applications with a constant load and speed, e.g. simple conveyor belts;
- Variable speed operation – Applications with variable load and speed, e.g. centrifugal pumps with variable flow.

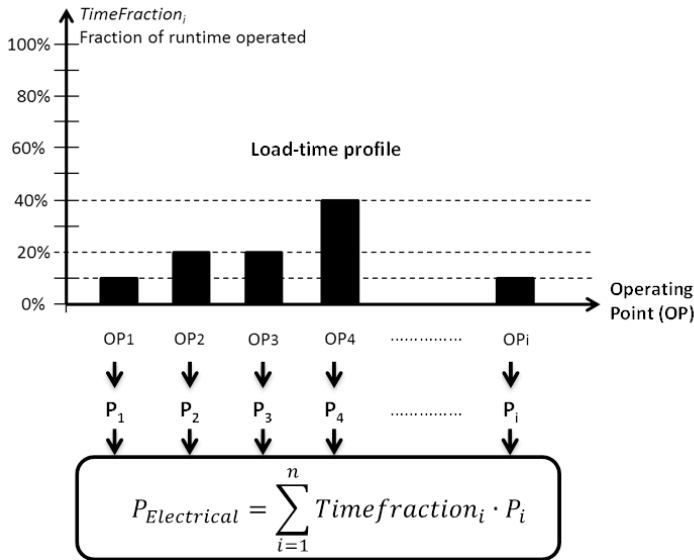

Figure 3: Typical power required by application over time fraction = load-time profile required to calculate the electrical energy needed.

For this case study, two application scenarios were defined by the means of operating profiles and a reference service life, to evaluate the use stage and the potential environmental improvements through higher efficiency levels. The two scenarios, displayed in Figure 4, were chosen to take into account a high duty, Scenario A), and a low duty operation, Scenario B), and to reflect the results then in this context. Both scenarios are basically variable speed operations, which are more common for motors with power ratings corresponding to the ones of this case study [Almeida 2014].

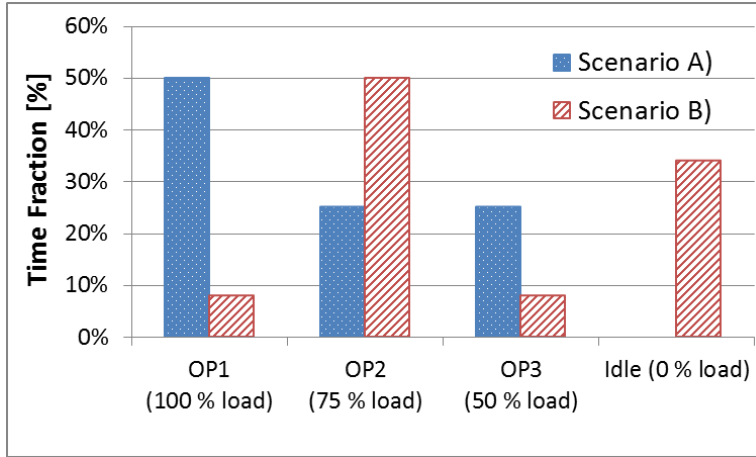

Figure 4: Graphical display of the two operating profiles corresponding to Scenario A) and Scenario B) applied in the case study.

The relevant parameters (speed, load and time fraction) of the two scenarios are displayed in Table 3; Table 4 lists the corresponding efficiencies of the motors of the different IE-classes, at the respective operating points.. For the reference of the comparative assessment, the IE2-motor, this then corresponds to the respectively defined functional unit laid down in the goal and scope (subchapter 2.3).

Table 3: Relevant parameters of two use stage scenarios applied in the LCA of the motors with different efficiency (IE) classes. The scenarios are characterized by an operating profile, i.e. the amount of time (percent of 24 h) the motor works at specific operating points (OP). The OP is characterized by the speed and load of the motor in terms of percentage of their nominal values.

Usage: Scenario A) / calculation scheme				
load	speed [%]	load [%]	time [%]	time [h]
operating point 1 (OP1)	100	100	50	12
operating point 2 (OP2)	100	75	25	6
operating point 3 (OP3)	100	50	25	6
Idle	0	0	0	0

Usage Scenario B) / calculation scheme				
load	speed [%]	load [%]	time [%]	time [h]
operating point 1 (OP1)	100	100	~8	2
operating point 2 (OP2)	100	75	50	12
operating point 3 (OP3)	100	50	~8	2
Idle	0	0	34	8

Table 4: Efficiencies of motors with different IE-classes at the operating points (OP) corresponding to Table 3.

Product, Efficiency [%] at OPs	OP1	OP2	OP3
Motor 1 (IE2)	94	94,6	94,5
Motor 2 (IE3)	95,5	95,8	95,4
Motor 3 (IE4)	96,4	96,6	96,3

The input flow of electrical energy was fed by “EU27 power mix”, as the currently available European average in the GABI database.

### 3.3 End-of-life stage

For end-of-life stage, current available technologies and (pre-)treatment steps are combined to a most likely, representative scenario based on [Kasper et al., 2015] and [IEC/TR 62635], an internal research project [Süß, 2007], and discussions in an European work group for motors, currently developing PCR for LCA of motors [CLC TC2 WG2], aligned EN50598-3. For the case study the scenario was defined as follows: The whole motor is disassembled into the main parts (housing, stator, rotor, windings), which are then shredded. This is then followed by material separation by physical properties, e.g. eddy-current and density, routing the different fractions to material recycling (metals, wood), energy recovery (insulation/impregnation,

plastics) and landfill (ceramics, recovery/recycling process losses). 5 % of losses were assumed for recovery and separation processes, whereas generic datasets were used for recycling, recovery and landfilling processes, including material specific recycling quotes and further necessary inputs.. Crosschecking with [Almeida 2008], [Almeida 2014] and [Karlsson and Järhed, 2000], this approach and the corresponding, high recycling quotes (~ 95 %) were assumed to be realistic. Potential credits, through the avoidance of virgin metals production and/or energy recovery through polymer materials, are then displayed as in the LCIA results for end-of-life stage; this means that there was no direct crediting to other life cycle stages within the model.

#### **4 Life Cycle Impact Assessment**

The following chapter now describes the results of the life cycle impact assessment, whereas their interpretation and discussion will follow in chapter 5.

##### *4.1 Life cycle impacts*

The results of the life cycle impact assessment with applied external normalization and weighting, using the normalization and weighting factors of the PEF guide for pilot studies (Version 1.6), for each of the motor types and life cycle stages for both usage scenarios are displayed in Figure 5.

Looking at the impact scores displayed, at first it can be stated, that the use stage is by far the most relevant life cycle stage, as the other life cycle stages are not visible in this scale. Secondly it can be seen that for both scenarios the increase in the motors' efficiency reduces the environmental impacts expressed in PE.

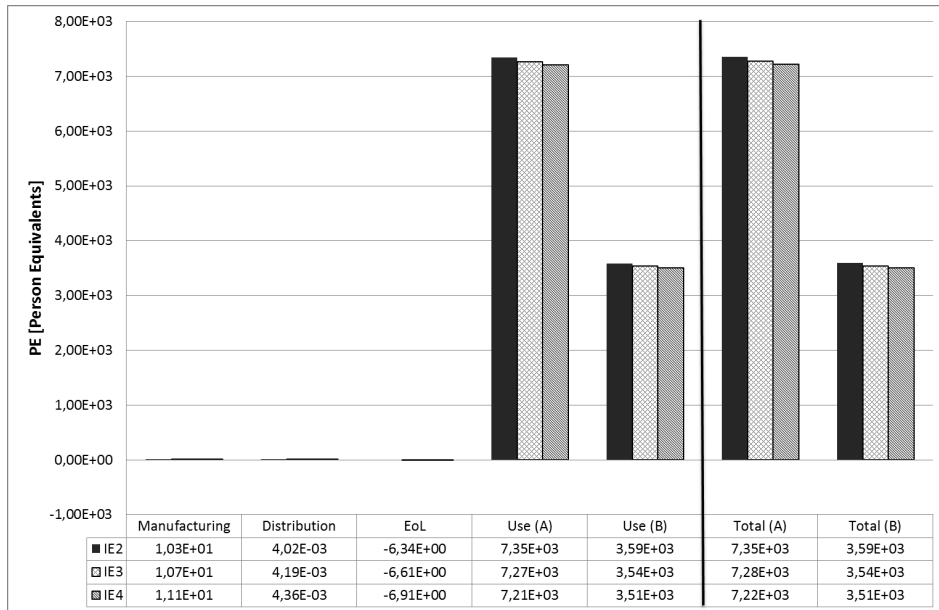

Figure 5: Externally normalized, weighted and aggregated LCIA scores in terms of Person Equivalents (PE) for the 3 electric motor types (IE2, IE3 and IE4).

Figure 6 now displays the data in PE per impact category. Based on this, it can be determined that the most relevant impact categories for electric motors are ionizing radiation (IR), water depletion (RD, w), and global warming potential (GWP), and all these are predominantly driven by the amount of electricity that is converted in the use stage of the motors.

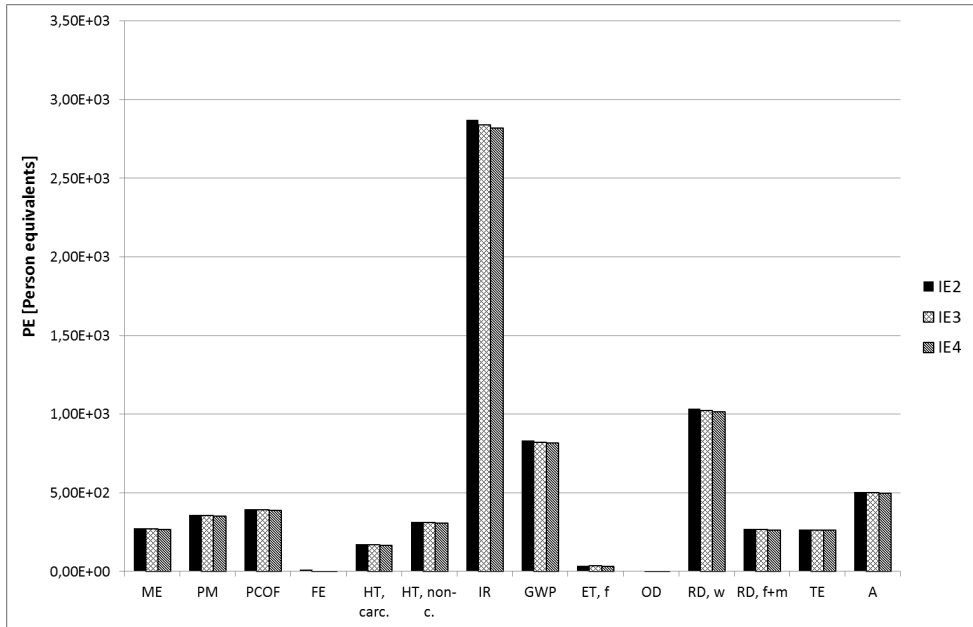

Figure 6: LCIA scores of the motors, summarized over the whole life cycle. (impact categories on x-axis according to Table 3).

To have a better view on the results of the manufacturing stage (comprising also the materials production, cf. section 2.4), the LCIA scores are displayed in Figure 7 without the dominating use stage, i.e. only for manufacturing, distribution and end-of-life.



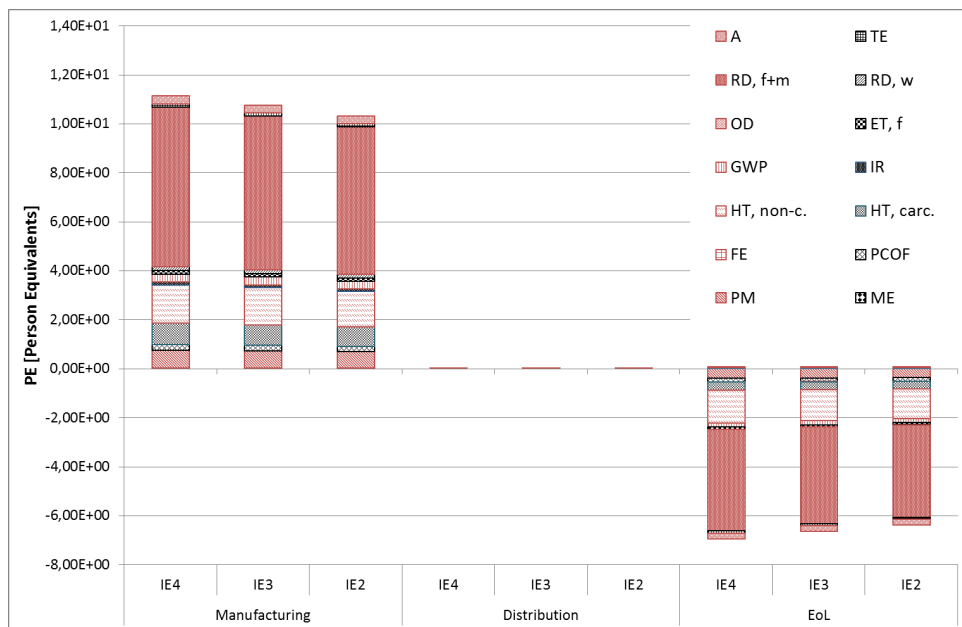

Figure 7: LCIA scores of manufacturing, distribution and end-of-life of the motors in PE.

Looking at this figure, it can be seen that the distribution of the contribution of the analyzed impact categories to the total score in PE is more-or-less comparable between the different motors. The small differences that are observed can be assigned to the change in the material composition between the motors. Secondly it can be seen, that the EoL stage corresponds to the manufacturing stage, which means on the one hand that due to the motors composition of mainly metals, the high recycling quotes theoretically compensate more than half of the impacts from manufacturing and material stage and therefore the increase in impacts with the higher energy efficiency are also partly compensated by a higher benefit from recycling. Thirdly, the figure shows that the distribution stage is indeed insignificant. Lastly, the figure also shows that fossil and mineral resource depletion, human toxicity and particulate matter are the most relevant impact categories at the manufacturing and end-of-life stages.

To evaluate the respective drivers at manufacturing stage, Figure 8 now shows these main impact categories, as well as the global warming and acidification potentials, and their respective contributors at the manufacturing stage of the IE4-motor in 100%-view

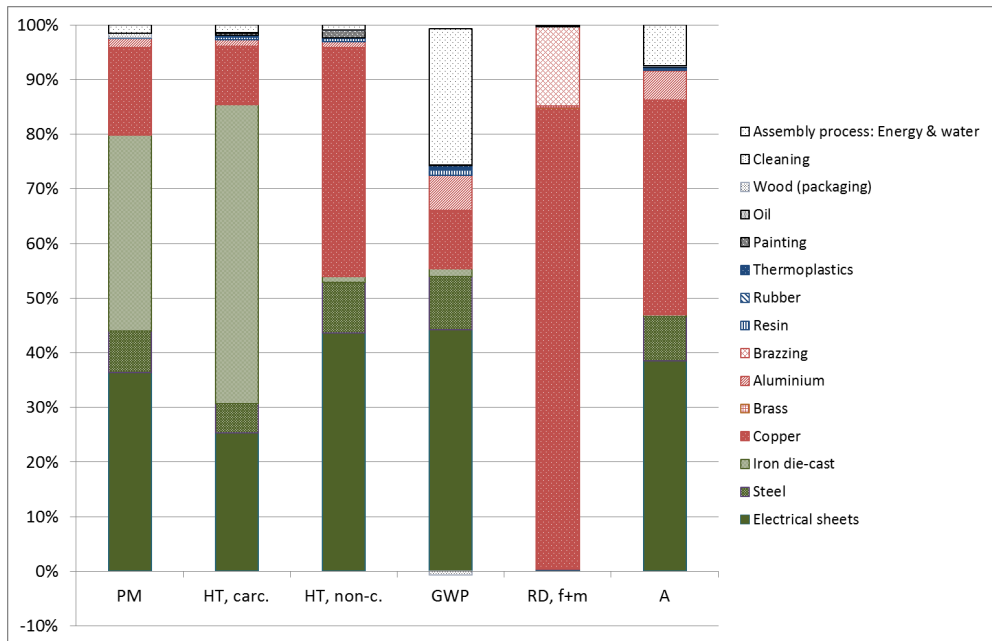

Figure 8: 100%-view of the LCIA scores of the main impact categories in PE of the IE4-motor at manufacturing stage broken down to the corresponding drivers.

Looking at this figure it can be seen that the main materials (copper, iron, steel) of the motors are also the main drivers, accounting for about 90 %, of these potential environmental impacts, besides acidification and global warming where the assembly process is also a main contributor due to its use of electricity. The materials in focus for further interpretation are the electrical sheets, steel and die-cast iron, as well as copper.

#### *4.2 Comparative analysis of the electric motor types*

Based on the results concerning the relevant impact categories and the dominance of life cycle stages, the comparative assessment of the electrical motors with different efficiency classes can be facilitated further.

To see if there are issues across the motor types, e.g. significant changes concerning the relevance of impact categories, an internal normalization in terms of “Division by Baseline” (DBB) was applied [Laurent and Hauschild, 2015], where the results of the IE2-motor provides the baseline. The results with an applied usage Scenario A) (see Table 1) are displayed in Figure 9. Here it can be seen that in that usage scenario all potential environmental impacts are reduced, and the reduction of the potential environmental impacts correlates with the increase of the efficiency classes. On average, electricity-related efficiency in the use stage is increased by about 1.2 % per efficiency class, and most of the potential impacts are then roughly reduced about 1 %. This is, however, not applicable for Human Toxicity (HT, cancer effects) where the reduction of these potential environmental impacts is lower.

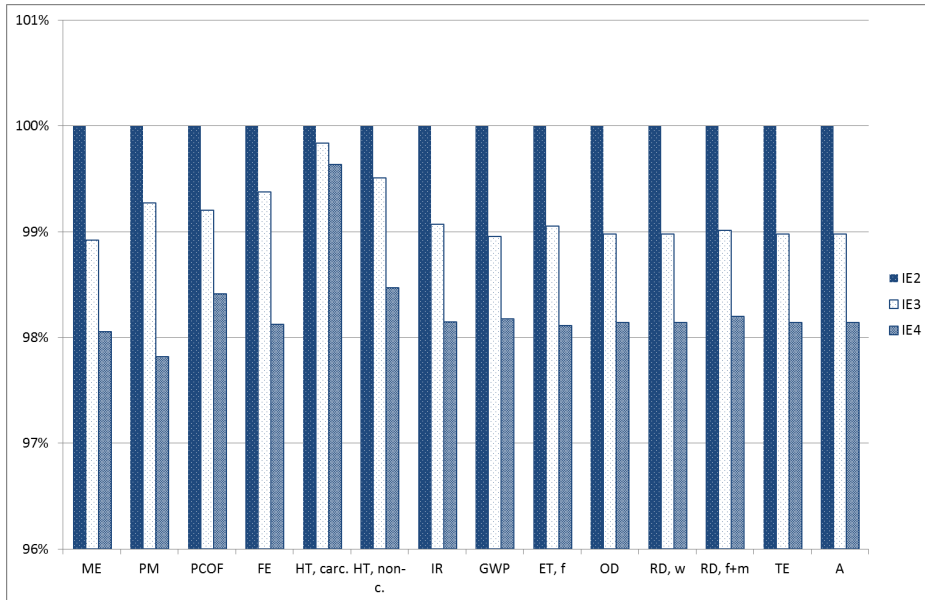

Figure 9: LCIA scores in DBB view with applied usage Scenario A).

The results of the life cycle impact assessment with the applied usage Scenario B) were evaluated accordingly, with applied internal normalization (DBB), and gave a comparable impression, besides human toxicity (cancer effects) which in this scenario even increases from IE3 to IE4. As the second difference it was recognized that the improvement of the environmental performance is even higher in all impact categories but Human Toxicity (cancer effects) in comparison to Scenario A).

According to the impact assessment, it can be summarized that the increase in the motors' efficiency reduces all environmental impacts over the complete life cycle in both usage scenarios, besides human toxicity (cancer effects).

## **5. Interpretation and discussion**

Based on the LCIA results of the previous chapter, the LCA can now be interpreted further. For all motor types, the dominance of the use stage is obvious, even at a lower duty operation profile (Scenario B)). Based on the normalized impact scores over the whole life cycle, the most relevant impact categories are ionizing radiation, water depletion and global warming potential. These categories are related to the electricity consumption during the motors' utilization and depend therefore strongly on the specific electricity mix of the region where the motors are operated. In the further, the interpretation is performed per life cycle stage:

### *5.1 Manufacturing and End-of-Life*

Manufacturing and end-of-life stages are described together, because they strongly correlated due to the fact that the material composition of the motors is a main driver for potential impacts and benefits occurring within these life cycle stages. The increase of materials, like copper or steel in this case, in the motor's composition results in higher impacts in manufacturing, which on the other hand, in theory are compensated to some extent by material recycling and/or energy recovery at the end-of-life stage. This relation is valid for all motor types (IE2 to IE4). Allocating the potential benefit of the end-of-life stage through recycling to the manufacturing (closed loop approach) stage, the environmental impact of manufacturing is compensated by 62 % in PEs, by 52 % in GWP and by 3 % in Human Toxicity (non-cancer effects). The end-of-life stage itself was not analyzed further within the case study, since these details (e.g. different recycling scenarios) were not in the scope of the study, but it should be considered that the potential credits through recycling are quite high, but assumed to be realistic for motors of this size and weight, due to their low material complexity and high amount of valuable metals with associated,

established separation and recycling processes (see also subchapter 3.3). Crucial for high recycling rates is to separate copper from iron, because copper negatively influences the recyclability of iron/steel [Alatalo et al., 2011]. This is taken into account by the disassembly of the main parts before shredding. Other end-of-life treatment scenarios, because theoretical recovery and recycling may not be always met in practice, will affect the relation between manufacturing and end-of-life stage. In other words, better recycling will compensate impacts associated with utilizing of more material more, lower recycling and/or recovery will compensate less. Looking at the normalized results of the LCIA of the manufacturing stage, the most relevant potential impacts are fossil and mineral resource depletion, human toxicity, ionizing radiation, global warming and particulate matter. The main, top 3, contributors to these impact categories were evaluated, accounting to about 90 % of impact within the respective category. The results are summarized in Table 5 for further interpretation.

Table 5: Summarized results of the life cycle impact assessment displaying the main impact categories with their main drivers for motors manufacturing.

<b>Main Impact category</b>	<b>Main drivers</b>
Resource Depletion, fossil + mineral	Copper, Brazing
Human toxicity, cancer effects	Electrical sheets, Iron (die-cast), Steel
Human toxicity, non-cancer effects	Electrical sheets, Steel, Copper
Acidification	Electrical sheets, Cooper, Steel
Global warming potential	Electrical sheets, Assembly process, Copper
Particulate matter	Iron (die-cast), Copper, Electrical sheets

In that context, results showed that the material selection in regard to improving the efficiency of motors is important concerning associated environmental impacts. Main contributors to the overall losses of the motor during use are losses in the functional materials copper and iron

(electrical sheets), as well as in the air gaps [Volz, 2010]. So, besides optimizing the motor construction (e.g. reduction of air gap losses) within the established motor technologies, increasing the efficiency basically requires more or higher quality material which reduces these losses – even though it has to be mentioned that this is a very simplified approach, because the motor concept would have to be adapted too – and in that context copper and electrical steel are the most important material fractions [Lemmens and Deprez, 2012]. Now from an environmental point of view, the electrical sheets basically increase impacts in the ionizing radiation category, global warming potential and particulate matter categories, whereas copper dominates the impacts of resource depletion and human toxicity (cancer effects) categories. Thus, hot spots in the motors' material composition are the material fractions copper and the electrical sheets. The electrical sheets primarily because of the mass used in the motor, the copper because of the associated processes to produce the material, especially from primary sources which are needed for copper wires [Cowley and McGowan-Jackson, 2004] [EU CI, 2015]. In terms of environmentally conscious design, a practitioner now would have to value the corresponding impact categories to justify his choice in regard to either reducing copper losses or the losses in the electrical sheets for improving a motor's efficiency. In that context it also has to be considered that – besides the problem of valuating – in the underlying characterization methods for resource depletion as well as toxicity still are under development and bear a higher level of uncertainty compared to e.g. the impacts related to energy consumption [Huijbregts, 2001] [ILCD 2011]. For resource depletion current discussions are dominated by the search for the definition of the “right” allocation base [Schneider et al., 2015]. Whereas for toxicity assessments, three major sources of uncertainty can be named: i) Available aggregated datasets still lack certain elementary flows for a robust characterization [Huijbregts et al., 2000], then ii)

fate and exposure factors do have strong correlation to the environment, like the geographical scenarios [Huijbregts et al., 2003] and then iii) the characterization itself (e.g. USEtox), is still rather young and thus under continuous development [Rosenbaum et al., 2008]. This has to be considered in any decision support context [e.g. Pennington 1999].

## 5.2 Use Stage

The entire use stage is a hot spot in itself, compared to the impacts associated with the other life cycle stages, where electricity consumption is the main driver for environmental impacts which are associated with the electricity generation from primary sources. Hence, the increase in efficiency of converting electric to mechanical power by the rotating electric machinery is the key to the reduction of these impacts. It has to be considered though, that the relation between the increase of efficiency and the reduction of potential environmental impact strongly depends on the applied power mix. So in case of a “green” power mix, dominated by electricity generation through renewable resources, efficiency gains in the motor will result in smaller reductions of environmental impacts, compared to power mixes relying primarily on fossil sources.

Looking at the efficiency of the motors (Table 4) it can be seen too, that the efficiency at the OP2 is higher than in OP1, which is currently regulated by the implementing measure on motors within the framework of the ErP directive. Therefore it can be argued – depending on the operating profile – whether the increase of the efficiency classes is the key to the “right” choice of the motor. Rather, it might make sense to utilize a more powerful, i.e. oversized, motor, which then runs at OP2 most of the time, instead using a higher efficient less powerful, i.e. right-sized, motor which correspondingly runs at OP1 for most of the time. This is also the explanation to the higher increase of environmental performance with the increased efficiency in usage Scenario



B), since there the motors run with a high share at OP2 (see Table 3). In this context it has to be mentioned that this does not apply to all motor technologies, as for instance synchronous motors do not have this behavior since their efficiency is more or less the same for all operating points.

### *5.3 Comparative Assessment*

The comparative life cycle assessment clearly indicated that any increase in efficiency is environmentally preferable with the applied usage scenarios (assumed 20 years of operational life) and current technological set-up for electricity generation. After external normalization and weighting of results, the study clearly indicated the benefits of an improved efficiency in terms of reduced impacts, even when applying a lower duty operating profile (Scenario B)). The extra effort when building a more efficient motor in manufacturing stage, due to the use of more material, as well as distribution, because of the higher weight, is compensated by higher credit at the end-of-life stage, as well as the savings when using the product. In this regard the pay-off between higher impacts in manufacturing and to the lower impacts in usage for the increased efficiency was calculated to about a month in terms of PE, and only to 8 days in GWP as a representative for the assessed impact categories, related to electricity consumption. The exchange of an IE2 motor with an IE4 motor reduces CO<sub>2</sub>-emissions by about 80.000 kg CO<sub>2</sub> eq. (4160 kg CO<sub>2</sub> eq. per year) in Scenario B) and by 145.000 kg CO<sub>2</sub> eq. (7240 kg CO<sub>2</sub> eq. per year) in Scenario A). The data for the comparison of the IE2 with IE4 motor, i.e. the days of operation after which additional efforts in materials, manufacturing and distribution are compensated by savings in the use stage, as well as potential credits from end-of-life, is summarized for PE, GWP, HTc and RD in Figure 11. In this context an additional scenario was added, to check how a different, worse in terms of recycling/recovery rates, approach would

influence the break-even in environmental impacts. Therefore only 50 % of the potential credits from the end-of-life stage were accounted to the motor system.

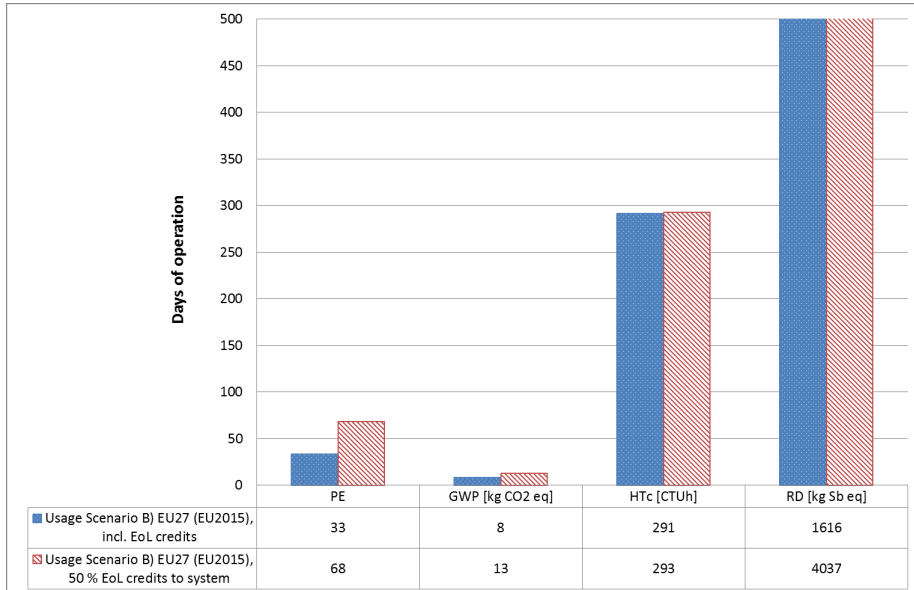

Figure 10: Graphic display of the break-even calculation for the exchange of an IE2-motor with an IE4-Motor in days of operation. It shows after how many days of operation the additional effort in material, manufacturing and distribution is compensated by savings in usage and credits for EoL.

Based on this data it can be seen that the additional effort for increasing the motors' efficiency corresponds in terms of GWP to an additional impact of 204 kg CO<sub>2</sub> eq, credits from end-of-life account for 116 kg, leaving net 88 kg CO<sub>2</sub> eq to be compensated at the use stage. Comparing this to the figures mentioned above, it's clear that this is compensated quickly. With lower recovery and recycling rates, the time period needed for break-even is extended, especially regarding the resource depletion (fossil, metals) indicator.

By applying an internal normalization by the means of DBB the impact categories' performance could be assessed individually in between the motors with different efficiency

classes. An increase of (Scenario B)) or a lower reduction of potential environmental impacts (Scenario A)) with increase of efficiency could be observed for human toxicity (cancer effects). This is caused by the higher utilization of copper material with the increase of the efficiency class. Since there are not enough savings in that category in the use stage, the total score over the whole life cycle increases with the applied use stage Scenario B). Looking deeper into this issue, the break even for this impact category would be reached, when exchanging a IE2 motor with a IE4 motor, after about 15 years in Scenario A) and after about 27 years in Scenario B). This should be considered in ecodesign decision support context with caution due to the issue of uncertainty of this impact category, as discussed previously. More generally this fact can be seen as an indication that there could be cases were this wouldn't be true (e.g. other usage scenarios with different load-time profile and/or shorter reference life time) or that when further increasing efficiency it can lead to higher impacts in certain impact categories, as toxicity impacts in this case. Now to further check the robustness of the obtained results, these points were addressed in the sensitivity analysis in the following section.

## **6 Data quality and sensitivity analysis**

To validate the LCIA results as discussed in the previous section, uncertainties and data quality in terms of representativeness and appropriateness have to be depicted as basis for the further sensitivity analysis and scenarios, which then lead to the final conclusions in chapter 7.

### *6.1 Representativeness and appropriateness of LCI data*

The representativeness and appropriateness of the LCI data is now discussed per life cycle stage.

### *Manufacturing stage*

Relevant data for modelling the manufacturing stage of the motors for that study are the supplied bill of material and energy consumption in the assembly process. The bill of material and weights were taken directly out of the engineering tool and can be rated of very good quality. Treatment of the materials and manufacturing steps of the parts are reflected by the aggregated generic data sets of materials or processes, supplied by thinkstep, and can be rated of good quality. The assembly process energy allocated by working hours is known to include a high level of uncertainty, as already mentioned in the goal & scope, but due to the dominance of the impacts associated with the materials themselves the importance can be rated rather low and the current approach can be rated as worst case scenario. As laid out above copper and the electrical sheets do have the highest influence, therefore these should be addressed by a sensitivity analysis to evaluate the limits of the discussed results in context to the decision support.

### *Use stage*

Data relevant for modelling (losses of the motors at the corresponding operating points) was taken from SinaSave [SinaSave 2016] and is based on the products technical documentations. Underlying test and calculation methods are standardized and applied in policy context. Therefore it can be rated as of very good quality. The applied use stage scenarios can be rated as representative, but it has to be considered that the application range of asynchronous motors is quite divers and results in different scenarios might vary. Especially in context it shall be mentioned that besides the operating profile, the operational life and the operating hours per years have a strong influence on the impacts related to the use of the motor. Both parameters correlated to the nominal power of the motors [Almeida et al., 2008]. Additionally to that it should be considered that the impacts from electricity generation are decreasing through the

increased contribution from renewable sources, especially wind power, as it is documented for instance for the European Union [Agora 2016]. This potential future energy scenario could affect the interpretation of the comparative assessment and hence should be addressed in a sensitivity check.

#### *End-of-life stage*

The end-of-life treatment process itself can be described as representative for the current state of the art of motor recycling in industrialized regions like Europe. Additional scenarios could be applied considering lower recycling and recovery rates, that would be applicable in other regions; or to analyze for instance the effect of the reuse of certain parts of the motor, reflecting current initiatives in Europe, as the circular economy package [EC 2015a] and standardization activities regarding material efficiency [EC 2015b]. For this case study, this context is rated as of minor significance, since the evaluation of environmental break-even in subchapter 5.3 showed that even when not crediting manufacturing with the benefits from the end-of-life stage, the additional impacts in manufacturing in terms of PE are compensated in use stage, low duty Scenario B), in less than 4 months.

#### *6.2 Sensitivity analysis*

As outlined in the previous section, copper and electrical sheets play a major role concerning the environmental impacts of the motors, especially in the comparative assessment when assessing the trade-offs between the life cycle stages when the efficiency of the motors is increased. Thus in the first part of the sensitivity check different datasets for copper as well as the electrical sheets were used. Additionally concerning the relevance as well as ongoing discussion around the limits of the assessment of the resource depletion impact category, the results were checked

by applying a different characterization model. Then the third check was performed by applying a potential EU2030, as well as EU2050, power generation scenario reflecting the developments in the EU concerning electricity provision.

*Robustness of the result against different materials background data*

In the study copper and the electrical sheets were identified as one of the drivers of the environmental impacts, especially in the manufacturing stage (and correlating in the end-of-life-stage), therefore a sensitivity check using different background data sets for these materials was performed concerning the robustness of the results and interpretation. Copper in the motor is used in the form of wires and has some influence on the efficiency of the motor as a reduction of the electrical losses in copper is one lever for increasing the motor's efficiency. For these wires only primary copper from electrolysis can be used. In the initial assessment a dataset for copper (electrolysis, 99,9999...%) in global context was used, since the complete supply chain is – in a general context – unknown or not further specified. Additionally available in the database was a corresponding dataset for copper wires in a European context supplied by the Copper Institute from 2012, which also seems to be applicable in the study. This dataset was then picked in terms of checking the results of the study. Figure 11 shows the externally normalized LCIA score of the IE4 motor's manufacturing stage with the two applied LCI datasets Cu(GLO) by thinkstep and the Cu(EU15) by the Copper Institute in comparison to visualize the differences.

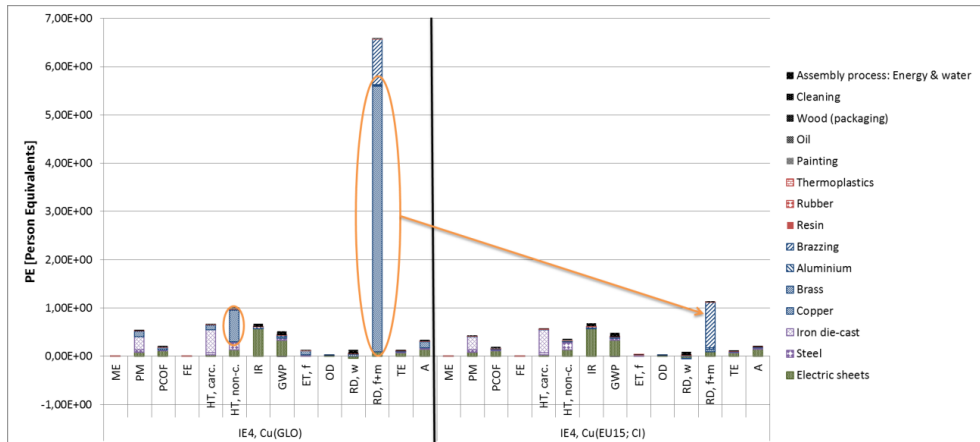

Figure 11: Normalized LCIA scores in PE of the manufacturing stage of the IE4 motor with the two different LCI datasets Cu(GLO) by Thinkstep and Cu(EU15) by the European Copper Institute.

The figure shows clearly the issue of the LCI dataset choice in regard to the interpretation of the LCIA results. So when picking the European Copper Institutes Cu(EU15) dataset, copper isn't a driver in regards to resource depletion and Human Toxicity (cancer effects) anymore and both impact categories' importance is reduced in that context. To put that into the context of the comparative assessment, again internal normalization by DBB was applied to the LCIA results over the whole life cycle, but there were only minor changes of the results, in the respective categories human toxicity and resource depletion, hence the overall interpretation stays valid.

Explanation to that lower rating could be outdated LCI data and/or missing elementary flows for proper characterization; or on the other hand more accurate data compared to worst case approximations due to lacks of detailed data. Looking at their issuing dates, option one seems more reasonable, since the European Copper Institute's free, association data set is from 2010, whereas thinkstep continuously maintains their purchasable background datasets [GaBi, 2016]. This has been verified by directly comparing the two datasets elementary flows and the EU15 copper dataset basically shouldn't be applied anymore.

The electric sheets were modelled with an aggregated dataset for the cold rolled steel coil by thinkstep, based on the fact that iron is the main component to both, assuming a standard cold-rolled non grain oriented electrical steel with 1-3 % of Silicon added used in the motors in the initial set-up of the assessment. In terms of a sensitivity check we used a dataset provided by a supplier of this electrical sheet material, thyssenkrupp Steel, assuming a better fit to reality and a higher degree of accuracy. Figure 12 displays the results for the IE4 motor respectively for all motor types in comparison to the initial assessment of the manufacturing stage.

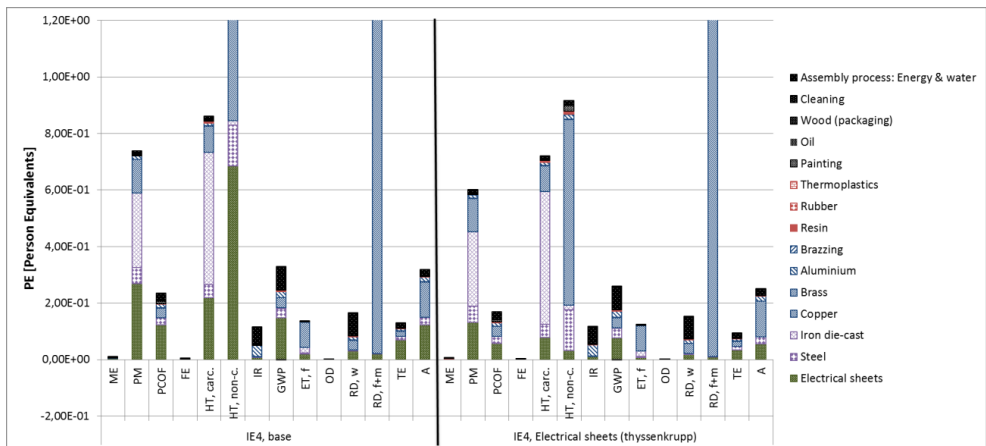

Figure 12: Normalized LCIA scores in PE of the manufacturing stage of the IE4 motor with the two different LCI datasets for steel by thinkstep and by thyssenkrupp Steel. The vertical axis is cut at 1.2 PE to have a better look at the changes of the impact categories besides resource depletion, which is dominated by copper and its course is known.

It can be seen that in all impact categories, where the electrical sheets have a significant contribution to the scores have changed, in all impact categories the electrical sheets contribution is lower with the more accurate dataset. Especially human toxicity decreases significantly, whereas for the others the reduction is more or less comparable. To put these differences into the



context of the comparative assessment of the motors with different efficiency classes, DBB was applied again to the LCIA scores of the whole life cycle.

Comparing these results with the initial assessment, again minor changes can be observed in regard to human toxicity where there's now a minor decrease instead of a minor increase as in the initial assessment. In context to toxicity impact assessment methods, this change can be regarded as insignificant, hence the interpretation as laid out in the previous chapter remains valid. Or to put it in other words, decision support should still be carried out carefully when based on these results in the toxicity category. This can generally be accounted to the fact that the use stage is dominant and significant changes in the LCIA scores of manufacturing stage become insignificant over the whole life cycle with the applied usage scenarios.

#### *EU2030/2050 scenarios for electricity production*

To check the obtained results, which predominantly are influenced by the impacts related to electricity generation, two additional scenarios were derived based on a publication of the German VDMA's group for power systems. Background of the scenarios is the increase of renewable energy sources, like wind and solar, for electricity generation. Therefore the available EU27 power mix by thinkstep was modified according to the figures in Table 6. The EU2030 scenario was derived based on the figures of the above mentioned report, whereas the EU2050 is an own assumption of a potential further development of the electricity generation.

Table 6: Parameters of EU2030/50 power mixes in percentage of the total contribution per energy source.

	EU2030 (Source: VDMA power systems [VDMA, 2010])	EU2050 (own projection)
Energy Source	Contribution [%]	Contribution [%]
Biogas	4	8
Biomass solid	4	4
Coal gases	0	0
Hard coal	6.5	2.5
HFO (Oil)	2.5	2.5
Hydro	12	14
Lignite	7	3
Natural gas	16	12
Nuclear	19	15
Photovoltaics	5	8
Wind	23	30
WtE	1	1
Additional parameters		
Grid losses	4.35	4.35
Own consumption	1.39	1.39

Figure 13 now displays the results of the life cycle impact assessment of Usage Scenario B) applying a EU27 grid mix (EU2015) adapted with the parameters of Table 6.

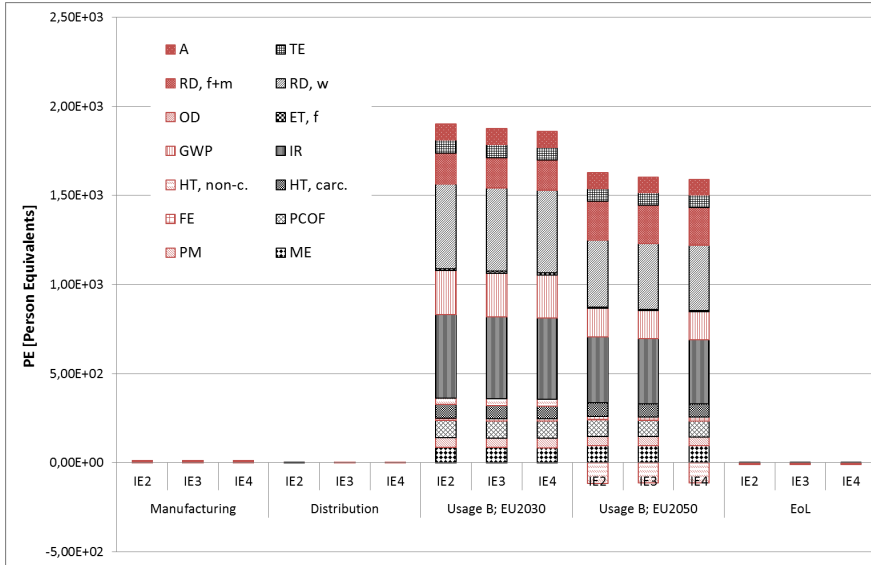

Figure 13: Normalized LCIA scores of motors with different efficiency classes in different electricity generation scenarios using the usage Scenario B). Details to the scenarios are provided in Table 6.

The results show that there's a significant reduction of the impacts associated with the electricity consumption through the increased contribution of renewable energy sources, but – even for the EU2050 projection – the impacts associated with the manufacturing stage, as well as distribution and EoL stages, are still several orders of magnitude lower than those associated with the usage stage. Hence even up to 2050 improving efficiency will be an important point in the EU to reduce environmental impacts driven by electricity consumption.

For the further analysis the environmental break-even for the exchange of an IE2 with an IE4 motor was calculated for the most relevant impacts by dividing the additional impacts of the motor with the higher efficiency at the materials, manufacturing, distribution and end-of-life stage through the savings in the use stage for the study's base case. This is shown in Figure 14 in comparison with the results from 5.3.

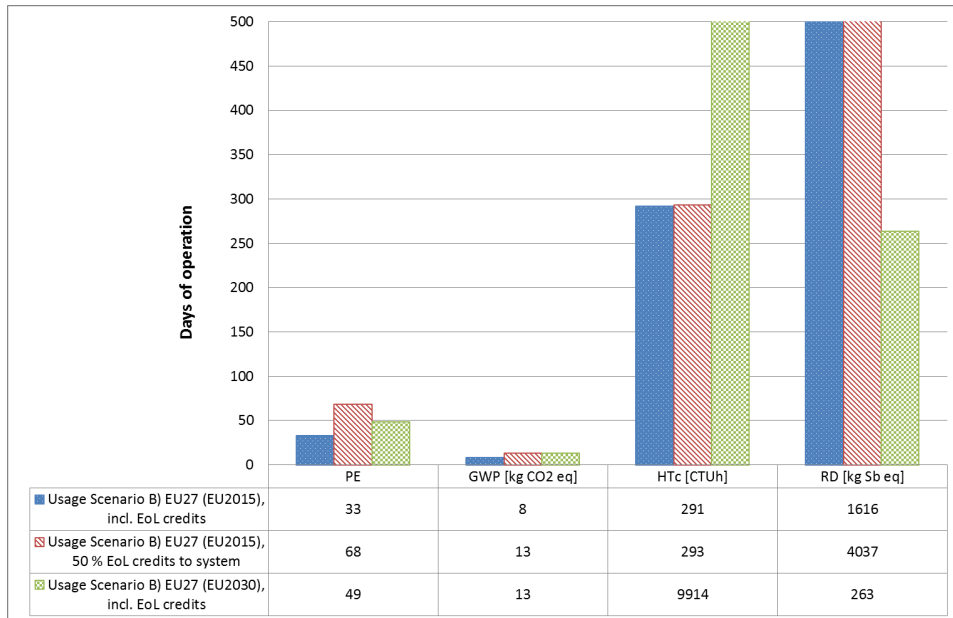

Figure 14: Environmental break-even calculation in days of operation, in normalized (PE) scores and in absolute figures in 3 different impact categories

According to this calculation it can be stated that through the increased contribution of renewable energy sources to the electricity generation, the break-even in PE, GWP and RD is achieved after a longer time period. Especially for HT (cancer effects) the increase in days of operation is high and is then exceeding the assumed service life. Interestingly there's a significant reduction of time period needed for the break-even in resource depletion, compared with the base case. This could be a topic of the characterization method and the allocation of impacts from resource consumption of electricity generation by renewable energy sources. Savings from increased energy efficiency in operation seem to be accounted for even higher than from non-renewables.

In PE and GWP the time period for the break-even increases when more of the electricity is generated from renewable sources.

## **7 Conclusions and further work**

The normalized and weighted results of the comparative life cycle assessment case study on electric motors with different efficiency classes led to the conclusion that in the current technological set-up, especially concerning electricity generation and potential scenarios with higher contribution from renewable resources, any improvement in efficiency in the motor's operation is environmentally beneficial, at least within the range of the usage scenarios applied in this study. This means that the trade-off between the life cycle stages is beneficial over the whole life cycle. Drilling this further down to the individual impact categories, a special behavior was observed for human toxicity (cancer effects), where the break-even between the additional effort for improving efficiency and the savings at use could only be reached after the assumed service life of the motor when more electricity is provided by renewable resources. Therefore managing this aspect will require special attention, especially considering the uncertainties and discussions underlying the available impact assessment methods, and decisions in ecodesign context should be taken carefully. This means that further research activities should tackle the aspect of the robustness of the characterization models for toxicity to enhance their applicability in decision support context. The same might apply for the resource depletion indicator which in the current guidance for PEF pilots is an aggregated category covering mineral, metal and fossil resources. The use of more mineral and/or metal resources therefore can be compensated by savings of fossil resources like in this case study. This may lead decision makers in the wrong direction, especially when both: energy related impacts as well as the resource depletion of minerals and metals need to be managed. End-of-life treatment scenarios also have a high

influence on this characterized impact through the crediting of the system under study with the benefits. This indicates that political initiatives as well as legislative acts tackling these issues have to bear that in mind or rather should improve the assessment methods before deciding and starting these initiatives to avoid burden shifting or a general dilemma.

For today's motor producers or rather LCA practitioners in industry, same applies when using LCA as a tool for decision support. The externally normalized results of the study indicate that future developments should still tackle the aspect of further improving efficiency, because in the current (and prospective) technological set-up for electricity generation, any reduction of consumption decreases environmental impacts. On the other hand the internally normalized results indicate a burden shifting between energy related impacts and toxicity impacts (and maybe to resource depletion if assessed individually for fossil and metal resources). Thinking this through it can be concluded that decision making supported by LCA is still very difficult because of the uncertainties through immature impact assessment and characterization models, generic secondary data and the lack of proper external normalization factors, reflecting the carrying capacity of the ecosystems and political consensus on the weighting of the individual impact categories.

The study also showed the relevance of the load-time profile, indicated by the comparison between the two usage scenarios, and the motor's service life. Generally, the motors' efficiency is higher in a partial-load condition around 75 % of nominal power compared to the efficiency at 100% load. Hence, it would be crucial to evaluate the environmental performance of a motor or rather a drive system optimized in context to the specific characteristics of the application scenario in comparison to gains achieved by the optimization of single components. Another point in that context is generalization of the results of the study to other motor sizes (nominal

power). Efficiency gains of motors with smaller nominal power, e.g. 11 kW, will be lower in absolute numbers, as well as the assumed service life be shorter (10-15 years), this could then lead to different results concerning the trade-offs or rather the environmental break-even of these impacts.

So when finally concluding on the deep dive into the trade-offs between life cycle stages in ecodesign context, it can be stated that these two aspects could be in the scope of further work to complete the picture of a relevant product category in an energy and material efficiency context.

## References

1. [COP21] United Nations Framework Convention on Climate Change, Taking the Paris Agreement forward, Reflections note by the President of the twenty-first session of the Conference of the Parties and the incoming President of the twenty-second session of the Conference of the Parties, 6 May 2016, [http://unfccc.int/paris\\_agreement/items/9485.php](http://unfccc.int/paris_agreement/items/9485.php) , accessed on 12.06.2016 (2016)
2. [COM 2010] Communication from the Commission: EUROPE 2020, a strategy for smart, sustainable and inclusive growth. COM(2010) 2020 final. [http://ec.europa.eu/europe2020/europe-2020-in-a-nutshell/targets/index\\_en.htm](http://ec.europa.eu/europe2020/europe-2020-in-a-nutshell/targets/index_en.htm). Accessed on 12.12.15 (2010)
3. [EC 2020] [http://ec.europa.eu/clima/policies/strategies/2020/index\\_en.htm](http://ec.europa.eu/clima/policies/strategies/2020/index_en.htm). Accessed on 12.12.15 (2015)
4. [EU 2009] Directive 2009/125/EC of the European Parliament and of the Council of 21 October 2009 establishing a framework for the setting of ecodesign requirements for energy-related products, OJ L 285, 31.10.2009, p. 10–35 (2009)
5. [COM 2008] Communication from the Commission to the Council and the European Parliament - Establishment of the working plan for 2009-2011 under the Ecodesign Directive, /\* COM/2008/0660 final \*/ (2008)

6. [SWD 2012] Establishment of the Working Plan 2012-2014 under the Ecodesign Directive, SWD(2012) 434 final
7. [EC 2014] European Commission, DG Energy, energy efficient products, electric motors, <https://ec.europa.eu/energy/en/topics/energy-efficiency/energy-efficient-products/electric-motors>, accessed on 27.06.2016 (2016)
8. [EU 2014] Commission Regulation (EU) No 4/2014 of 6 January 2014 amending Regulation (EC) No 640/2009 implementing Directive 2005/32/EC of the European Parliament and of the Council with regard to ecodesign requirements for electric motors, OJ L 2, 7.1.2014, p. 1–2 (2014)
9. [EC 2015a] European Commission/Press release”/Closing the loop: Commission adopts ambitious new Circular Economy Package to boost competitiveness, create jobs and generate sustainable growth”, IP-15-6203, 02.12.2015, [http://europa.eu/rapid/press-release\\_IP-15-6203\\_en.htm](http://europa.eu/rapid/press-release_IP-15-6203_en.htm), accessed on 15.06.2016. (2015)
10. [EC 2011a] European Commission: Roadmap to a Resource Efficient Europe, COM(2011) 571 final, Brussels, 20.09.2011. (2011)
11. [EC 2011b] European Commission: A resource-efficient Europe – Flagship initiative under the Europe 2020 Strategy, COM(2011) 21 Brussels, 26.01.2011. (2011)
12. [EC 2015b] M/543 COMMISSION IMPLEMENTING DECISION C(2015)9096 of 17.12.2015 on a standardisation request to the European standardisation organisations as regards ecodesign requirements on material efficiency aspects for energy-related products in support of the implementation of Directive 2009/125/EC of the European Parliament and of the Council. (2015)
13. [VHK 2005] Van Holsteijn en Kemna BV: Methodology Study Eco-design of Energy-using Products, MEEUP Methodology Report, final, 28.11.2005
14. [MEERP 2015] Methodology for the Ecodesign of Energy-related Products. <http://www.meerp.eu/>. Accessed on 15.12.2016



15. [Almeida 2008] De Almeida A.T., Ferreira, F., Fong J., Fonseca P.: EUP Lot 11 Motors Final Report, University of Coimbra, 18.02.2008
16. [Almeida 2014] De Almeida A., Falkner H., Fong J.: EuP Lot 30: Electric Motors – Task 4: Technical analysis existing products, final, ENER/C3/413-2010, (2014)
17. [ISO 14040] ISO 14040:2006, Environmental management - Life cycle assessment - Principles and framework (2006)
18. [ISO 14044] ISO 14044: 2006, Environmental management - Life cycle assessment - Requirements and guidelines (2006)
19. [ILCD 2010] ILCD Handbook: General guide for Life Cycle Assessment - Detailed guidance, EUR 24708 EN – 2010, [http://publications.jrc.ec.europa.eu/repository/bitstream/JRC48157/ilcd\\_handbook-general\\_guide\\_for\\_lca-detailed\\_guidance\\_12march2010\\_isbn\\_fin.pdf](http://publications.jrc.ec.europa.eu/repository/bitstream/JRC48157/ilcd_handbook-general_guide_for_lca-detailed_guidance_12march2010_isbn_fin.pdf), accessed on 05.11.2015 (2010)
20. [ILCD 2011] ILCD Handbook: Recommendations for Life Cycle Impact Assessment in the European context, EUR 24571 EN – 2011, <http://epica.jrc.ec.europa.eu/uploads/ILCD-Recommendation-of-methods-for-LCIA-def.pdf>, accessed on 05.11.2015 (2011)
21. [Bjørn and Hauschild, 2015] Bjørn, A. & Hauschild, M.Z.: Introducing carrying capacity-based normalisation in LCA: framework and development of references at midpoint level, Int J Life Cycle Assess 20:1005 (2015)
22. [EN 50598-3] EN50598-3:2015, Ecodesign for power drive systems, motor starters, power electronics and their driven applications - Part 3: Quantitative eco design approach through life cycle assessment including product category rules and the content of environmental declarations (2015)
23. [IEC 60034-30-1] IEC 60034-30-1:2014, Rotating electrical machines – Part 30-1: Efficiency classes of line operated AC motors (IE code) (2014)

24. [EC 2016] European Commission: Environmental Footprint Pilot Guidance document - Guidance for the implementation of the EU Product Environmental Footprint (PEF) during the Environmental Footprint (EF) pilot phase, version 5.2, February 2016 (2016)
25. [Hermann et al. 2012] Hermann, Gama, Helman: Calculating the carbon footprint of electronic products with life cycle assessment, PE International white paper (2012)
26. [EN 50598-1] EN50598-1:2015, Ecodesign for power drive systems, motor starters, power electronics & their driven applications - Part 1: General requirements for setting energy efficiency standards for power driven equipment using the extended product approach (EPA), and semi analytic model (SAM) (2015)
27. [EN 50598-2] EN50598-2:2015, Ecodesign for power drive systems, motor starters, power electronics & their driven applications - Part 2: Energy efficiency indicators for power drive systems and motor starters (2015)
28. [Auer and Weis, 2014] Auer, Weis, 2014: New standard on ecodesign for power drive systems, motor starters, power electronics & their driven applications: Introducing the Extended Product Approach and product category rules for motor systems, Session 2.14.: Impacts from legislation, lecture 2.14.1. In: CARE Innovation 2014 Conference, Vienna.
29. [SinaSave 2016] Siemens AG, SinaSave:  
<http://www.industry.siemens.com/drives/global/en/engineering-commissioning-software/sinasave/Pages/Default.aspx>, accessed on 15.05.2016 (2016)
30. [Kasper et al., 2015] Kasper, A.C., Gabriel, A.P., de Oliveira, E.L.B., de Freitas Juchneski, N.C., Veit, H.M.: Electronic Waste Recycling, H.M. Veit and A. Moura Bernardes (eds.), Electronic Waste, Topics in Mining, Metallurgy and Materials Engineering, DOI 10.1007/978-3-319-15714-6\_9
31. [CLC TC2 WG2] CLC TC2 WG2 – environmental aspects of electric motors, EN50XXX, 2nd working group draft, tbp (2015)

32. [Süß 2007] Süß: Hauptumweltkriterium im Lebenszyklus eines Schützes (German), Masterthesis, HAW Amberg-Weiden (2007)
33. [IEC/TR62635] IEC/TR 62635:2012, Guidelines for End of Life information provision from manufacturers and recyclers, and for recyclability rate calculation of Electrical and Electronic Equipment (2012)
34. [Karlsson and Järhed, 2000] Karlsson, Järhed: Recycling of electrical motors by automatic disassembly, Meas. Sci. Technol. 11, 350–357 (2000)
35. [Laurent and Hauschild, 2015] Laurent, Hauschild: Normalisation, Chapter 14 of M.Z. Hauschild, M.A.J. Huijbregts (eds.), Life Cycle Impact Assessment, LCA Compendium – The Complete World of Life Cycle Assessment, DOI 10.1007/978-94-017-9744-3\_14 (2015)
36. [Alatalo et al., 2011] Alatalo, Tidblad Lundmark, Arfa Grunditz: Electric Machine Design for Traction Applications Considering Recycling Aspects -Review and New Solution, Proceedings of the Annual Conference of the Ieee Industrial Electronics Society — 2011, pp. 1836-1841 (2011)
- [Volz 2010] Volz: Ratgeber Elektrische Motoren in Industrie und Gewerbe: Energieeffizienz und Ökodesign-Richtlinie, Deutsche Energie-Agentur GmbH (dena) (2010)
37. [Lemmens and Deprez 2012] Sumper, Baggini: Electrical Energy Efficiency: Technologies and Applications, First Edition, Chapter 7 – Joris Lemmens and Wim Deprez: Electric Motors (2012)
38. [Cowley and McGowan-Jackson 2015] Cowley, McGowan-Jackson: Kennecott Copper Environmental Profile, Life Cycle Assessment, Kennecott Utah Copper Corporation (2004)
39. [EU CI 2015] European Copper Institute: The environmental profile of copper products – A cradle to gate life-cycle-assessment for copper tube, sheet and wire produced in Europe, [www.copper-life-cycle.org](http://www.copper-life-cycle.org), accessed on 22.10.2015 (2015)
40. [Schneider et al. 2015] Schneider, Berger, Finkbeiner: Abiotic resource depletion in LCA – background and update of the anthropogenic stock extended abiotic depletion potential (AADP) model, Int J Life Cycle Assess 20:709-721 (2015)

41. [Pennington 1999] Pennington: Letter to the Editor: Comment: Uncertainty in LCIA of Toxic Releases, *Int J Life Cycle Assess* 4 (2) 62-64 (1999)
42. [Huijbregts et al. 2000] Huijbregts, Thissen, Jager, van de Meent, Ragas: Priority assessment of toxic substances in life cycle assessment. Part II: assessing parameter uncertainty and human variability in the calculation of toxicity potentials, *Chemosphere* 41 575-588 (2000)
43. [Huijbregts 2001] Huijbregts: Uncertainty and variability in environmental life cycle assessment, PhD thesis, Institute for Biodiversity and Ecosystem Dynamics, University of Amsterdam (2001)
44. [Huijbregts et al. 2003] Huijbregts, Lundi, McKone, van de Meent: Geographical scenario uncertainty in generic fate and exposure factors of toxic pollutants for life-cycle impact assessment, *Chemosphere* 51 501-508 (2003)
45. [Rosenbaum et al. 2008] Rosenbaum, Bachmann, Swirsky Gold, Huijbregts, Jolliet, Juraske, Koehler, Larsen, MacLeod, Margni, McKone, Payet, Schuhmacher, van de Meent, Hauschild: UESTox – the UNEP-SETC toxicity model: recommended characterisation factors for human toxicity and freshwater ecotoxicity in life cycle impact assessment, *Int J Life Cycle Assess* 13:532-546 (2008)
46. [Pennington 1999] Pennington: Letters to the Editor, Comment and Reply, Comment: Uncertainty in LCIA of Toxic Releases, *Int. J. LCA* 4 (2) 62 - 64 (1999)
47. [GaBi 2016] Thinkstep: GaBi Databases, <https://www.thinkstep.com/software/gabi-lca/gabi-databases>, accessed on 23.03.2016
48. [Almeida et al. 2008] Almeida, Ferreira, Fong, Fonseca: EUP Lot 11 Motors Final Report February 2008, ISR-University of Coimbra, 2008
49. [Agora 2016] Agora Energiewende (2016): Energy Transition in the Power Sector in Europe: State of Affairs in 2015. Review of the Developments and Outlook for 2016, 097/02-A-2016/EN (2016)

**JP-III: A NEW, INNOVATIVE SET OF STANDARDS FOR  
DRIVE SYSTEMS: INTRODUCING AND TESTING THE  
EXTENDED PRODUCT APPROACH FOR TACKLING THE  
ECODESIGN OF SYSTEMS IN APPLICATION CONTEXT**

**MANUSCRIPT SUBMITTED FOR PUBLICATION IN JOURNAL OF  
MANUFACTURING SYSTEMS**

A new, innovative set of standards for drive systems:  
Introducing and testing the extended product  
approach for tackling the ecodesign of systems in  
application context

*Johannes Auer<sup>1,2,\*</sup>, Niki Bey<sup>2</sup>, Benno Weis<sup>3</sup>,*

<sup>1</sup> Department for Environment, Health & Safety, Process Industries & Drives Division, Siemens AG, 90475 Nuremberg, Germany;

<sup>2</sup> Department of Management Engineering, Division for Quantitative Sustainability Assessment, Technical University of Denmark, 2800 Kgs. Lyngby, Denmark;

<sup>3</sup> Department for Research & Development, Business Unit Motion Control, Digital Factory Division, Siemens AG, Frauenaaracher Str. 80, 91056 Erlangen, Germany;

\* **Corresponding Author:** Johannes Auer, Siemens AG, PD EHS, Gleiwitzerstr. 555, 90475 Nuremberg, Germany. E-Mail: [johannes.auer@siemens.com](mailto:johannes.auer@siemens.com)

**KEYWORDS** Ecodesign; Drive Systems; Pump Application; Extended Product Approach; Energy Efficiency; Eco Efficiency.

## **Abstract**

In the context of the Energy-Related Product Directive (ErP), which addresses various products in terms of their energy efficiency, a new European standards series, EN 50598, was developed to support the ecodesign of complete drive systems with regard to their application, e.g. pumps, fans. It provides a general methodology for the energy efficiency standardization of any extended product including a motor system – a key circumstance formerly not addressed. For this, EN 50598 introduces the Extended Product Approach (EPA) and provides energy efficiency indicators (EEI) for the respective drive system, including measurement and calculation methods. The standard enables product committees for driven equipment with included motor systems to work with the relative power losses of the included motor system, e.g. power drive systems, (PDS) in order to calculate the system energy efficiency aspects for the entire extended product. The standard also covers requirements for environmental declarations and product category rules for life cycle assessments of motor systems. This paper now explains in a concise manner key aspects and constraints behind the new comprehensive standard and, furthermore, establishes links to environmental conscious design [ECD], eco-design and energy-efficiency [EE] with life cycle assessment [LCA] and the concept of functional unit [FU], all under a practical decision-maker's perspective. A corresponding LCA case study shows the potential benefits of this holistic life cycle approach to eco-design on system level in regard to their applications.

## **1 Introduction**

The Energy-Related Products (ErP) Directive of the European Union [EU 2009] addresses products with a significant contribution (active or passive) to energy consumption in Europe. These products are assessed with a defined methodology in certain lots to evaluate potential improvements in terms of efficiency and to define the necessary measures. These are then regulated via so-called implementing measures in the form of EU regulations. One aspect of these implementing measures are the energy efficiency classes for electric motors introduced on the market from January 2015 [EC 2014; EU 2014]. Associated with the implementing measures are harmonized European standards describing necessary procedures to ensure compliance with the regulation, for instance in terms of the measurement methods for energy efficiency determination [CLC 2014]. One point often not considered and/or not addressed in terms of energy efficiency is the aspect of application within a system, whereas previous case studies and other research work showed the importance of system design regarding environmental and economic performance. For instance do electric motors placed on the EU market have to comply with energy efficiency class IE3 or IE2 when operated with a variable speed drive (VSD), but operating a fixed-speed application with a VSD just generates additional losses compared to directly networked operation with starters and contactors, whereas for variable speed applications, for instance in certain pumps and ventilation systems, the VSD can really improve efficiency [Thomas 2012]. This paper analyses, how applying an extended product approach may support decision-making in such a situation.

In order to guide and support practitioners, the European standardization organization CENELEC was commissioned by the European Commission to set out harmonized standards for the eco design and efficiency determination of drive systems (M/470, M476) [CLC 2014]. Within CENELEC, the technical committee TC22X for power drive systems, working in close



collaboration with other technical committees involved with the directive, regulations and the associated, harmonized standards (such as TC17B, TC2 and CEN TC197) has elaborated a new family of standards, the EN50598 “Ecodesign for power drive systems, motor starters, power electronics & their driven equipment”, which was issued in January 2015. The standard applies to drive systems in the power range from 0.12 kW up to 1000 kW and consists of 3 parts:

- [EN50598-1:2015] describes the extended product approach (EPA) to derive energy efficiency indicators (EEI) using semi analytical models (SAM) and the requirements which must be met to apply this approach to drive applications,
- [EN50598-2:2015] standardizes the efficiency determination of frequency converters and their driven applications,
- [EN50598-3:2015] describes the application of a qualitative and quantitative eco-design process, including product category rules for life cycle assessments and the content of environmental declarations.

Now in the further, the concept of the EPA can be pretty much seen as a key for approaching the interface of applications to systems (solutions) and the SAM as a key for the interface of a given system to its components. This issue, i.e. proper definitions of the interfaces between the elements “application”, “system” and “components”, often also is an issue in LCA case studies and corresponding environmental declaration schemes, for decision support. Therefore, the EPA and SAM can be seen as a key for approaching the concept of the functional unit (FU) originating from LCA. As a test of this idea, this paper presents a case study, which was set up to evaluate potential environmental and economic benefits by means of LCA and life cycle costing [LCC], combined in the Siemens Eco-Care-Matrix. In this case study, two drive systems were evaluated in context of two pump application scenarios, differentiated by their operating profiles,

comparing both economic and environmental performance. Main purpose of this paper is to (i) describe the context of “ecodesign” and associated standardization activities, then (ii) to explain the EPA approach and (iii) to test it in an eco-efficiency approach.

This paper now provides a brief overview of the historic development of eco-design, environmentally conscious design and energy-efficiency regarding policies and standards. Subsequently, the main aspects of the EN50598 standard are described, including the bridge from the concept of the EPA to the FU in LCA. After this, we describe the results of a corresponding eco-efficiency case study we conducted in order to test the concept. Following this, we critically discuss key aspects, draw conclusions and provide an outlook.

## **2 Current state-of-the-art of energy-efficiency and environmental conscious design standards**

### **2.1 General**

This chapter is meant to provide a non-exhaustive overview or background to the standard discussed in the paper, aiming to provide an impression of the often challenging task of elaborating overarching standards based on consensus.

Standardization is the process of developing technical standards in mutual agreement of various stakeholders, in detail defined in the work modes of the standardization bodies. Standardization enhances compatibility, interoperability, safety and quality and it can also facilitate commoditization of formerly custom processes. Therefore the implementation of standards in industry and commerce became highly important with the onset of the Industrial Revolution and the need for high-precision machine tools and interchangeable parts [IEC 2010; ISO 2015; ISO 2016]. International Standards (IS) now provide a common language for the technical world, supporting global trade as a means of preventing technical barriers to trade due to national standards. Based on the historic development of standardization bodies on national levels, today there are mainly two well recognized international organizations, the ISO, the International Organization for Standardization, dealing with general standards like e.g. paper sizes and management systems, and the IEC, the International Electrotechnical Committee, which provides IS for all electrical, electronic and related technologies. Further complexity in a global context aroused through the installation of another level for standards development on regional level. The European SBs, the so-called European Standards Organizations (ESOs) – CEN, CENELEC and ETSI – were installed by the European Commission in 1973 to foster the harmonization of standards in the Euro-pean Economic Area (EEA). The regional SBs are also part of the international SBs and the Vienna Agreement [ISO/CEN 1991] provides the

foundation of cooperation between ISO and CEN, as the Frankfurt Agreement for IEC and CLC [IEC/CLC 2016]. National Committees (NC) then represent the national interests within the IEC and the ISO, as well as in Europe in the CEN and CENELEC committees by delegating experts to the international or regional standardization projects and by mirroring these projects on national level. Today, roughly 85 % of all national standards projects are European or international in origin [DIN 2016], whereas most standardization projects on European level are closely related to European legislation or initiatives. For the further it also has to be considered that there are horizontal standards, defining common rules and requirements applicable to all products, systems or organizations under the scope of the SB, and product specific standards, defining standards for specific products or applications. For that the SBs have set-up horizontal Technical Committees (TCs) and vertical, product specific, TCs. This is visualized in **Figure 1** exemplarily for Germany.

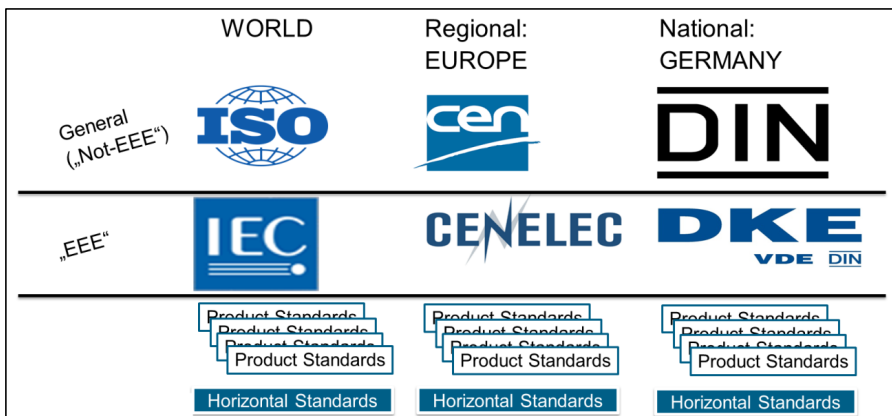

**Figure 1.** Overview of the three levels of standardization – international, regional and national – and the corresponding standardization bodies by the example of Europe and Germany. Vertical TCs produce product standards, horizontal TCs horizontal standards, applicable by or adaptable to the vertical TCs.

To summarize, one has to keep in mind that there are three levels of standardization – global, regional and national – and primarily two organizations or product scopes, the world of electrical and electronic equipment (EEE) and the general world of “non-EEE”. From economic perspective it’s favourable to have standards issued on the highest possible level of harmonization (to avoid trade barriers), but on the other hand often regional or national initiatives initiate corresponding projects on their level. Then, especially when standards are associated with legal requirements (in Europe called harmonized standards), a global harmonization after the standard can get tricky. Additional complexity comes in since EEE is often utilized in non-EEE products and IEC and ISO requirement should be harmonized or at least be consistent in principle too.

## **2.2 Energy-efficiency of drives**

The aspect of energy-efficiency of drives and especially the motors, as rotating machinery the base of the drive system for converting electric into mechanical energy, has quite some history. Associated standards on performance testing were introduced on national level as early as 1964 (US: IEEE 112), leading then to the IS IEC 60034-2 in 1996. Currently IEC 60034-1:2010 is the state-of-the-art in performance testing of electric motors, and 60034-2-1:2014 for losses determination and efficiency testing. IEC 60034-30-1 then defines the International Efficiency (IE) classes for AC line-fed motors, superseding or complementing the classes defined in the US by the National Electrical Manufacturers Association (NEMA) – standard efficiency, high efficiency and premium efficiency – and in the EU by the European Committee of Manufacturers of Electrical Machines and Power Electronics (CEMEP) – low (EFF3), medium (EFF2), high efficiency (EFF1). North America (USA, Canada and Mexico) was the leading region for promotion higher efficiency motors through voluntary agreements and legislative acts. In the US

in 1992 the Energy Policy Act [EPA 1992] as a governmental act passed by Congress and became effective 1997. Its purpose was to reduce US dependence on imported petroleum and improve air quality by addressing all aspects of energy supply and demand, including renewable energy, alternative fuels, and energy efficiency. EPA 1992 required 1-200 horsepower general-purpose motors manufactured or imported for sale in the United States to meet federal minimum efficiency levels. Continuous development in regard to broadening the scope and increasing the minimum efficiency levels, led to the currently applicable energy conservation standards for certain commercial and industrial electric motors issued by the U.S. Department of Energy (DOE). Motors covered by the rule include open and enclosed design, 600 volts and below, 1-500 horsepower; 2, 4, and 6 and 8 poles; NEMA Designs A and B. For NEMA Design C, the tabulated efficiencies are the same, but for 1-200 horsepower, 4-6-8 poles only. The effective date of the rule is May 29, 2014 and compliance with the standards will be required for motors produced or imported by June 1, 2016 [Boteler & Malinowski, 2015].

In 1998 a voluntary agreement supported by CEMEP and the EC was established and signed by 36 motor manufacturers, representing 80% of the European production of standard motors. This agreement defined a target to promote more efficient AC 3-phase induction motors, based on the classification scheme (EFF1-EFF3) mentioned above. Based on the classification scheme there was a voluntary undertaking by motor manufacturers to reduce the sale of motors with the current standard efficiency (EFF3). The CEMEP/EU agreement was a very important first step to promote motor efficiency classification and labelling, together with a very effective market transformation. Low efficiency motors (EFF3) have essentially been removed from the EU induction motor market which is a positive development. Still in 2009 Regulation (EC) 640/2009 in context with the “EcoDesign” directive was issued by the European Commission to set

minimum efficiency standards for motors on a regulative basis, applying the IE classes from the IS mentioned above. A shortcoming of the regulation that was claimed then, was the issue of system design [CAPIEL 2016], the efficiency of the system in context of the application. As explained in the introduction this led to the standardization request by the EC to CLC to develop a standard coping with efficiency of drive related systems [CEMEP 2015].

### **2.3 Environmentally conscious design**

The notion of protecting the environment started with the discovery of significant air, water and soil pollution associated with human activity in the 1960s. This led to environmental protection laws in the 1970s and 1980s, forcing companies to hire environmental specialist to react to these circumstances. The worldwide recognition led to the first International Conference on the Environment in Rio in 1992 and to various voluntary initiatives, standards and guidelines all over the world. Consciousness on the environmental issues of products raised significantly throughout the 1990s, as disruptive technology innovations, especially in electronics, were happening in shorter cycles – effecting business models, products life cycles, as well as consumption patterns – leading to increases in waste and associated environmental impacts. This caused the authorities to tackle this issue by regulations or incentives, as well as through extending the producers responsibility over the whole life cycle [Pigosso et al., 2015; Jugend et al., 2016].

The different national or regional approaches to this topic led to the demand of standardizing the environmental conscious design process on global scale. Here the world of standardization provides a proper foundation and ISO stepped in and assembled a Strategic Action Group on the Environment (SAGE), which concluded after an analysis that standards related to the management of environmental aspects would help to generally improve the situation, through

increase of the environmental performance of the companies and reduce or remove trade barriers, and hence the ISO 14000 standards series was born. In 1992 the ISO/TC207 was founded to develop and maintain the standard series, issuing the first edition of 14001 setting the requirements of an environmental management system (EMS), based on the plan-do-check-act (PDCA) principle, adopted from the Quality Management System (QMS) standard (ISO 9001), in 1996 [Rondinelli & Vastag 2000; Forsyth 1996]. Today a third party certified EMS is worldwide recognized and pretty much expected of international companies. Noteworthy within the ISO 14000 standards, is the technical report (TR) [ISO TR 14062:2002], issued in 2002 dealing with environmental aspects of product design, and is [ISO 14006:2011], providing guidelines for incorporating eco-design aspects into the EMS. Further there's an [ISO Guide 64:2008], initially from 1997, which guides experts in standardization how to address environmental issues in the corresponding product standards. Additionally in the current context of quantitative approaches and declarations, the ISO standards ISO 14040/44 defining the Life Cycle Assessment methodology and the [ISO 14020:2000] series [ISO 2012], dealing with environmental labels and declarations, have to be mentioned, since they are correlating to evaluating and expressing environmental impacts of product systems, which is part of the environmentally conscious design process.

On the other hand, IEC picked up that topic too, by installing a dedicated advisory group – the Advisory Committee on Environmental Aspects (ACEA) – which reports to the Standardization Management Board (SMB), which considers all aspects of the protection of the natural environment against detrimental impacts from a product, group of products or a system using electrical technology, including electronics and telecommunications, and in 1995 issued a guide on how to include environmental aspects in electrotechnical product standards [IEC Guide



109:2012]. Additionally a dedicated TC, the TC111, was installed and in 2005 the IEC Guide 114 on environ-mentally conscious design and the integration of environmental aspects was issued by them. This guide then became the already mentioned [IEC 62430:2009], an IS on environmentally conscious design in 2008. In principle comparable to the ISO documents mentioned above. Additionally noteworthy, concerning environmental aspects in the world of IEC standards today, are standards and reports related to materials and substances, like [IEC 62474:2012] on material declaration and the [IEC 62321:2008] series on determination of levels of certain restricted substances (lead, mercury, cadmium, etc. from the EU RoHS directive, which expanded its influence to various other regions).

To summarize, ISO 14001 links management of an organization's processes with environmental impacts, but does not include design management processes. ISO 9001 covers the design management process, but does not explicitly cover environmental impacts. ISO/TR 14062 and IEC 62430 assist incorporation of the evaluation of environ-mental aspects and impacts into the design and development process, but as such, they do not fully explain the activities involved within an environmental and business management framework, such as those described in ISO 14001. The connection of these illustrates the relationship between the aforementioned International Standards, their scope of knowledge and their relationship with this International Standard, which links all three areas and related documents, is illustrated in **Figure 2** [ISO 14006:2011].

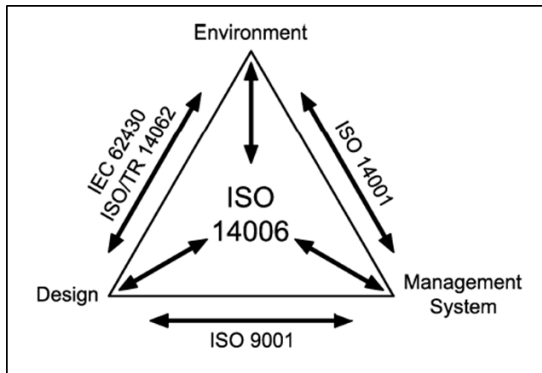

**Figure 2.** Illustration of the relationship between the aforementioned International Standards, their scope of knowledge and their relationship with the International Standard ISO 14006, which links all three areas and related documents [ISO 14006:2011].

As laid down in the previous sections, the provision of a harmonized, holistic system standard taking its potential applications into account, is a very challenging endeavor, due to its dependency on the product and the associated standardization world (ISO and/or IEC), as well as the level of the initial demand for the standard (national, regional, world). In developing the extended product approach, as explained in the introduction, at least three IEC (or CENELC)-related product TCs had to be involved in order to build the drive or rather motor system, then potential applications had to be mapped, which in this case were ISO-related. Then the standardization request or mandate came from the EC in connection with a European regulation, but both – the (drive) system, as well as the application – were to be marketable and sellable all over the world. The successful outcome of this complex but by practitioners highly looked-for endeavor is explained in the next subchapter/section.

## 2.4 Extended Product Approach

### 2.4.1 General

As stated above, the EN50598-1 specifies a methodology to determine the energy efficiency index (EEI) of an application, based on the concept of semi-analytical models (SAM). The methodology is called the extended product approach, EPA. It enables product committees for driven equipment (i.e. the extended product – EP) with included motor systems, to work with the relative power losses of the included motor system in order to calculate the overall system energy efficiency aspects for the extended product. The extended product and its components are illustrated in **Figure 3**.

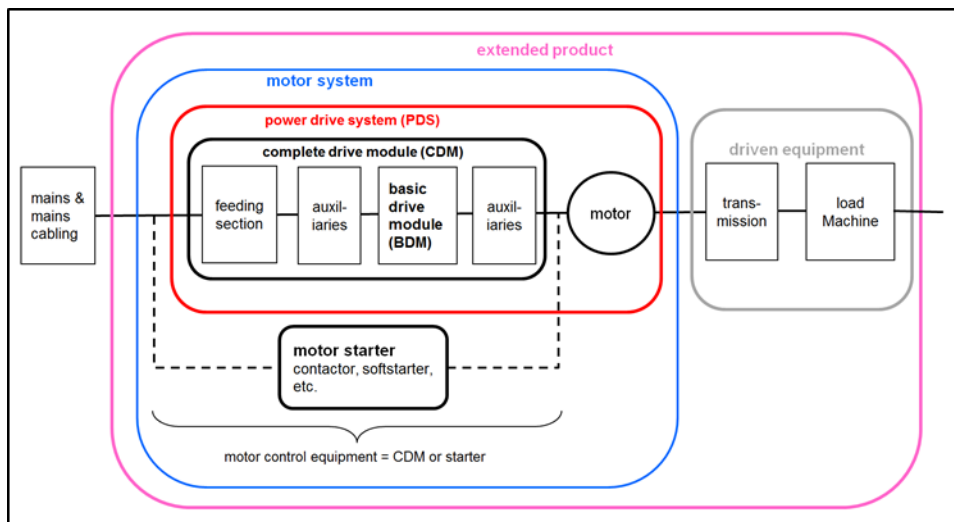

**Figure 3.** The extended product (EP) is defined as the motor system and the driven application. The motor system is defined as a power drive system (PDS – complete drive module and motor) or motor starter and motor.

A key necessity articulated and operationalized in EN 50598, which was not addressed in former standards, is that the system energy efficiency calculation has to be based on specific

calculation models for speed/load profiles, load-time profiles and the relative power losses of appropriate torque versus speed operating points. The standard also specifies the tasks and responsibilities of the different stakeholders in creating or using these extended product standards.

#### 2.4.2 Workflow and requirements for the semi-analytical model (SAM)

The determination model for the losses or the energy efficiency index of an extended product is called the "semi analytical model (SAM)", which includes physical and mathematical parameters and calculation algorithms of the subparts of an EP.

Figure 4 illustrates the application of the EPA including the tasks to be performed by affected stakeholders. It also visualizes the complexity and need for collaboration of the involved stakeholders and the need for a harmonized approach (e.g. consistency between the standards produced by different technical committees) through standardization.

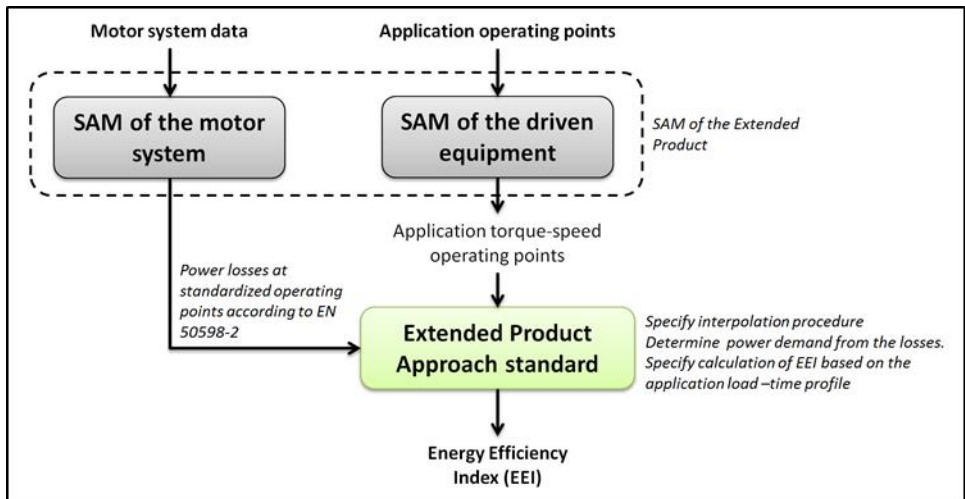
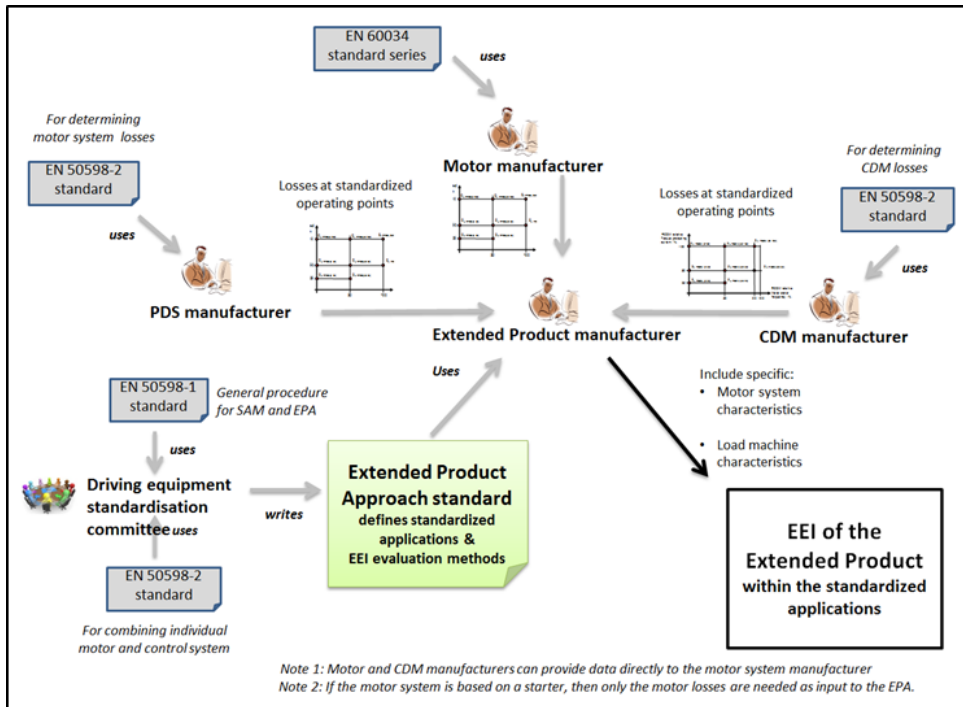

Figure 4. Illustration of the workflow for application of the EPA based on SAM

**Figure 4** also shows how the SAM of the motor system (left-hand side) is linked to the SAM of the driven equipment (right hand side). The links in-between both semi analytical models are the load loss points of the motor system (e.g. PDS) and their permissible tolerances. The actually required operating points have to be defined by the semi analytical model of the driven equipment.

The motor system data (including the specific SAM) containing the losses (e.g. PDS, PDS losses) is defined in EN50598-2, whereas the semi analytical energy consumption models of the PDS-driven application (right-hand side of Figure 2) have to be drafted by their responsible product committees using the same approach. **Figure 5** shows how the different data sources have to be combined.



**Figure 5.** Illustration of the different stakeholders affected by standardized determination of the energy efficiency index for extended products, such as driven applications, by combining data from different sources.

It is the responsibility of the technical committees for specific applications to standardize publicly available SAMs for their applications.

The SAMs for the subparts of the extended product are necessary in order to determine the overall power losses of the extended product. The outcome of the SAM, considering the most relevant energy efficiency aspects of all components of the system, can be used to calculate the energy efficiency index (EEI). This index then allows a quantitative distinction to be made between efficient and inefficient solutions for an application for which the extended product can

be used. This EEI value therefore has to be provided by the manufacturer in a metric scheme, for instance in the user's documentation or the catalogue.

### **2.4.3 SAM main characteristics**

The energy savings that can be achieved, or in other words the design of the most efficient system for a certain application, often depends on the operating point (OP) at which the extended product is operated. Two application-related characteristics, the torque or power versus speed profile and load-time profile, are particularly useful for describing the extended product and the way it is operated. These two characteristics can be used as input data to derive the right motor control equipment of the extended product in terms of energy efficiency performance.

#### ***2.4.3.1 The torque or power versus speed profile***

This profile describes how the torque required by the driven equipment depends on its speed. It essentially depends on the type of driven equipment.

The torque or power versus speed profile describes how the torque  $T$  or power  $P$  required by the driven load varies with its speed  $n$ . The power is also the product of torque and speed.

Most existing driven equipment can be categorized into one of the basic torque and power vs speed profiles shown in **Figure 6**.

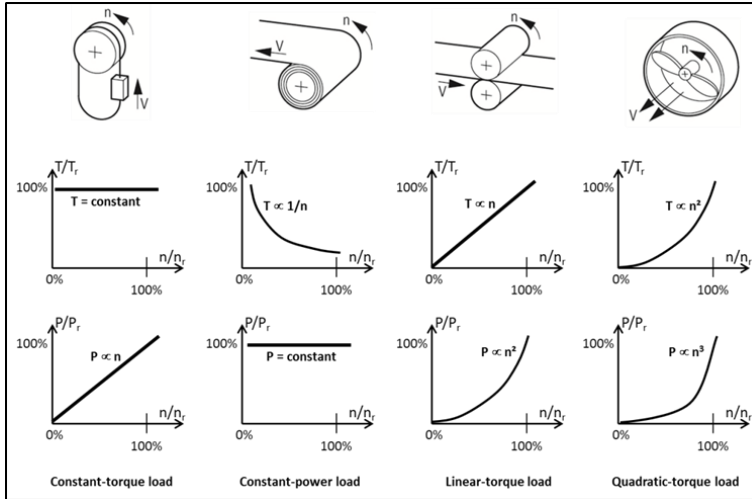

**Figure 6.** Typical torque/power vs. speed profiles for different extended products

#### 2.4.3.2 *The load-time profile*

This profile describes the various power levels required by the driven equipment, including standby, and the fraction of time during which the equipment is operated at these levels. The load-time profile essentially influences the sizing of the motor system and how the extended product is operated in practice.

The desired behavior of the extended product, as well as the characteristics of the motor, is defined by one or more operating points at which the motor will have to be operated.

Depending on the process demands, the motor may not be running at rated output power all the time. Part load is a situation where the application requires reduced torque and/or speed compared to the rated values.

The efficiency of an extended product heavily depends on the load level. Furthermore, standby (SB) losses of soft starters and CDMs have to be considered. They are present in periods



where the power section is disabled but the control is still supplied. Standby losses are losses generated, for example, by the power supply of the control section.

To estimate the efficiency of an extended product and compare several potential control solutions, it is therefore essential to know which levels of mechanical and electrical power are needed by the extended product and in which time fraction.

To calculate the electrical energy needed, the individual required electrical power supplies have to be multiplied by their time span. Time fractions in percentage terms have to be based on the whole operating time over one productive year of the installation.

An example of operating points over time is shown in **Figure 7**.

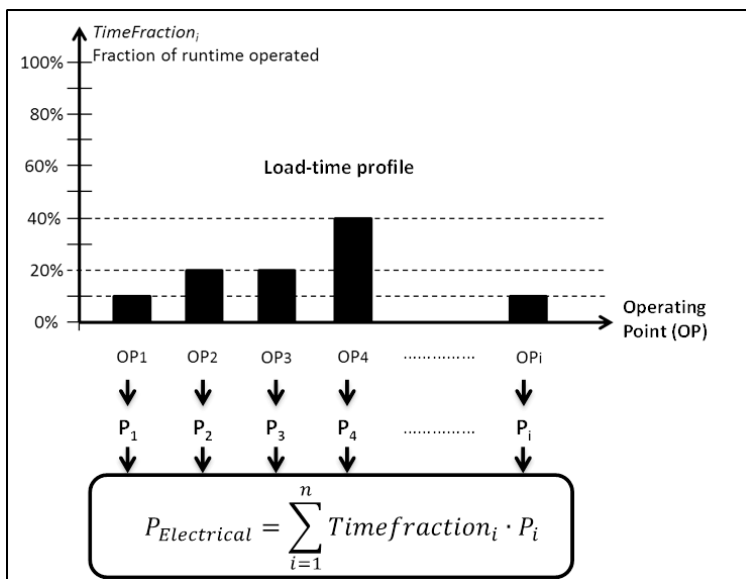

**Figure 7.** Typical power required by application over time fraction = load-time profile required to calculate the electrical energy needed.

The duty profile describes the requirements of the extended product in terms of mechanical power. For each Operating Point OP<sub>i</sub>, the electrical power P<sub>i</sub> that must be supplied by the mains

depends on the mechanical power and the overall extended product losses (or equivalently its efficiency) at this level.

The weighted average electrical power  $P_{\text{electrical}}$  required to run the extended product as desired is:

$$P_{\text{Electrical}} = \sum_{i=1}^n (\text{Timefraction}_i \cdot P_i) \quad (1)$$

The weighted average electrical power is directly relative to the electrical energy consumption (in e.g. kWh) required by the extended product during a certain runtime period:

$$E_{\text{Electrical}} = P_{\text{Electrical}} \cdot \text{Runtime} \quad (2)$$

The weighted average electrical power (or equivalently electrical energy) can be calculated for several potential control strategies suitable for the extended product (e.g. switchgear and CDM) and this information used to choose the most efficient one.

#### **2.4.4 Application of the extended product approach (EPA)**

As stated above, application of the EPA including the (individual) SAMs to determine the EEI of an extended product relies heavily on the collaboration of the involved stakeholders. The EPA itself is basically the combination of the SAMs of the involved (required) system components as regards the application.

The basic steps that consequently have to be taken by the extended product (driven system, application) technical committees are the following:

- specification and standardization of one (or more) torque versus speed and load-time profiles, considering typical loads and service conditions
- definition of an SAM for the extended product based on the eight operating points (torque versus speed) specified in EN50598-2,

- if necessary, definition of an appropriate method to determine losses at intermediate operating points,
- Specification of a method to derive an EEI (including tolerances) for the extended product.

These steps are summarized in **Table 1** including the relevant inputs and outputs.

**Table 1.** Basic steps from a SAM to an EEI via EPA

	<b>Input</b>	<b>Output</b>
<b>SAM Motor System (MS)</b>	Motor system characteristics (physical components, rated power...)	Losses of MS at standardized operating points
<b>SAM Extended Product (EP)</b>	Output of SAM MS + characteristics of EP	Losses of EP at standardized operating points
<b>Extended Product Approach</b>	Output of SAM EP + requirements relating to the application (load-time profiles, operating time...)	Energy efficiency index of EP for the application

The EPA is consequently a merger of two (or more) SAMs based upon a set of relative losses at a determined torque/power versus speed operating points and a load profile of the driven equipment [EN 50598-1:2015].

This links directly to the concept of the functional unit in life cycle assessment, as it provides a standardized approach to the description of the interface between the application to the underlying (motor) system and its included components. Hence it can be seen as a key enabler to performance evaluations like eco-efficiency tools, e.g. Eco-Care-Matrix, utilizing results from LCA and LCC. **Figure 8** visualizes this idea.

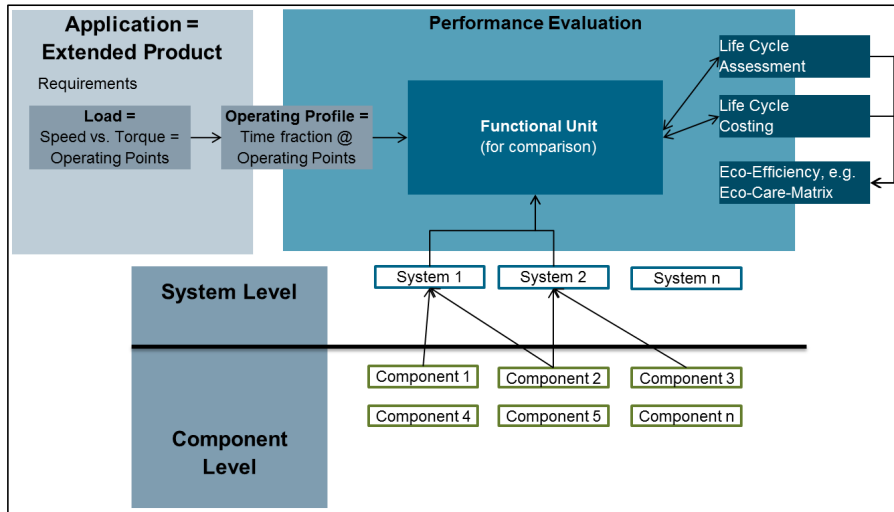
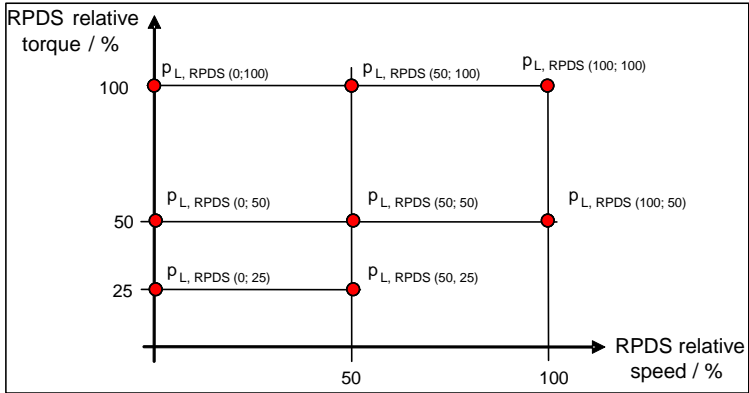

**Figure 8.** Graphical display on how the EPA can be seen as a key enabler to performance evaluations like Life Cycle Assessment, Life Cycle Costing and Eco-Efficiency assessments, like the Eco-Care-Matrix.

#### 2.4.5 Classification of frequency converters and power drive systems

This part of the standards family, the EN 50598-2, basically applies the EPA to drive systems and standardizes the EEI (IE- and IES classes). It also standardizes the calculation and test procedure for losses, including losses of reference components (such as reference PDS, CDM and loads/motor) and the mathematical model for their calculation.

The losses of a PDS (complete drive module and motor) depend largely on operating points (as well as ultimately the load profile – see section 2.4.4). To minimize the effort required, eight operating points were defined at which losses have to be determined by the respective manufacturer. These are displayed in **Figure 9**.



**Figure 9.** Operating points for loss determination of power drive systems.

Since a frequency converter has no speed or torque, the relative output frequency (modulation) and the relative current corresponding to the operating point are used for loss determination in this case. These are displayed in **Figure 10**.

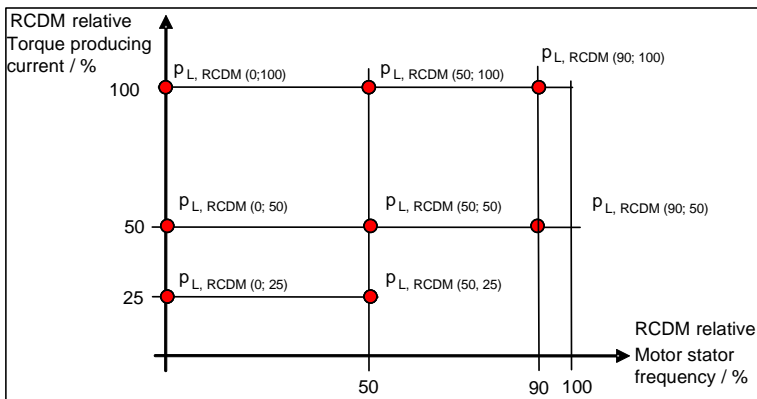

**Figure 10.** Operating points for loss determination of frequency converters (complete drive module).

As well as the nominal operating points, seven further part load points are defined in the standard, allowing a determination of losses by linear interpolation or extrapolation within the first quarter of the diagram.

To determine losses at the rated operating point, a control factor of 90 % is set to avoid over-modulation. Otherwise, the control factors of the frequency converters correspond to the operating points of the drive system. Some of these operating points are at very low speeds with output power at almost zero, as well as efficiency, independently of high or low losses. Losses are consequently the leading indicator of drive system performance in these cases.

The losses of frequency converter and power drive systems determined in this way enable users, e.g. in pump applications, to determine the most efficient solution for their system via the EPA explained in section 2.4.3 using a SAM.

Additionally, these losses form the basis for the comparable classification of frequency converters as well as drive systems according to IE classes (International Efficiency). For motors (low voltage standard motors), these have already been defined in [IEC 60034-30-1:2014]. For frequency converters, classification is carried out through comparison to a reference device, which is defined in the standard as a “state of the art” 3-phase voltage source inverter with 2-level technology and a nominal voltage of 400 V. To evaluate the IE class of the frequency converter, losses are determined at 90 % control factor (corresponding to 100 % torque building current) and compared to the losses of the reference device. If losses are approximately the same (+/- 25 %), the converter is rated IE1. If losses are lower, it is rated IE2 and in the case that losses are higher, it has to be rated as IE0, in either case more than the standardized tolerance of 25 %.

For drive systems, determination of the IES-class (International Efficiency for Systems) works basically the same way. IES1 covers the range of  $\pm 20\%$  of losses in a reference drive system. This is illustrated in

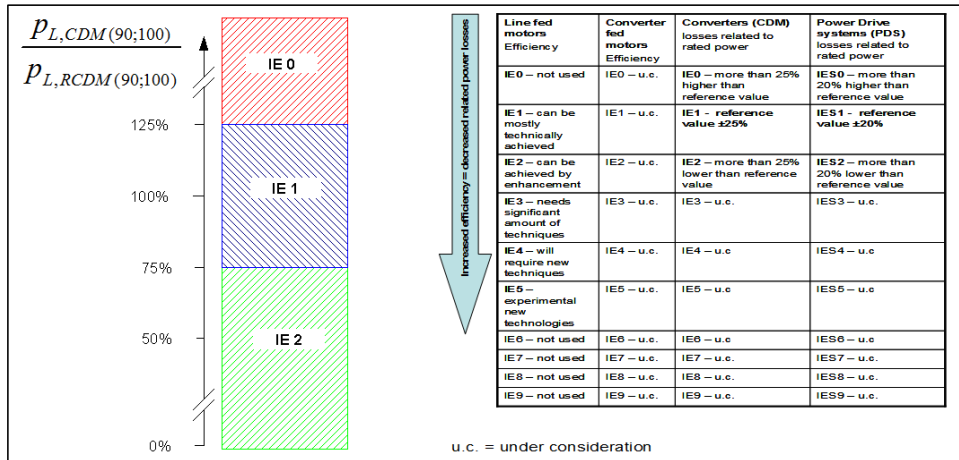

**Figure 11.** Illustration of IE class evaluation of frequency converters and drive systems.

#### 2.4.6 The definition of an ecodesign process, including product category rules for life cycle assessments and the content of environmental product declarations

This third part of EN 50598 specifies the process and requirements for implementing environmentally conscious product design principles (ECD), for evaluating ecodesign performance and for communicating potential environmental impacts of power electronics (e.g. complete drive modules, CDM), power drive systems and motor starters, all used for motor-driven equipment in the power range of 0.12 kW up to 1000 kW and low voltage (up to 1000 V) applications over their whole life cycle.

It defines the content for two different environmental declarations based on EN ISO 14021:

- The basic version, which will be referred to in this context as environmental declaration type II, with basic data and qualitative statements on ecodesign;

- The full version, which will be referred to in this context as environmental declaration type II+, based on a life cycle assessment and including quantitatively evaluated potential environmental impacts. Here, the general principles of EN ISO 14025 are taken into account and product category rules [PCR] for motor system components are included to ensure a harmonized approach. For full compliance to ISO 14025, further a declaration program would have to be joined, facilitating the requirements of a verification process.

An environmentally conscious design process culminates in a declaration of the potential environmental impacts or environmental claims of the components of a motor system in an environmental declaration or footprint.

ECD requires the identification, measurement and reporting of particular impacts. IEC 62430 describes the principles of ECD with the goal of reducing the potential environmental impacts of products and is referred to in the EN50598-3 standard.

As mentioned before, the standard leaves the manufacturer two choices (basic: qualitative; full: quantitative) on how to approach and implement ECD. The process itself has to be described in the manufacturer's (design) process instructions and if possible should be integrated into the management system (e.g. ISO 14001 or 9001) of the company. If the ECD is an integral part of a certified management system, third party verification through the certification audits is assured. If the manufacturer has no certified management system, the assurance of verification must be provided by internal audits.

This is the basic qualitative approach. It requires manufacturers to identify the main environmental issues of their products and to define appropriate improvement strategies in the context of factors such as energy efficiency, material usage (e.g. legislative requirements) and



recyclability. This can be done, for instance, by adding these topics and strategies to the product requirement and feature specifications and by involving relevant functions such as environmental specialists in the design process. Benefits for manufacturers include a systematic approach to all relevant environmental and compliance issues, e.g. substance legislation such as RoHS, or other directives such as WEEE. The outcome can also be used for qualitative environmental statements on the product level, in context of this standard as a basic environmental declaration referring to ISO 14021 type II environmental declarations.

In addition to the principles of the basic approach, a life cycle assessment [LCA] provides the possibility to quantify the ECD. By quantification, manufacturers can be sure of really focusing on the most relevant environmental issues and of quantifying improvements in terms of a reduction of, for instance, CO<sub>2</sub> emissions. Since an LCA requires a large amount of work, a smart approach is the key to ensure efficient implementation. For instance, manufacturers can define product families and assess these using selected key products. If these product families are homogeneous in terms of the manufacturing technologies and material composition used, potential environmental impacts can then even be approximated using linear regression. In case of a full ECD approach using an LCA, the data can also be used for full environmental declarations as defined by the standard, provided the standardized product category rules (PCR) are applied.

For LCA-based environmental declarations, the standard defines PCRs (according to ISO 14025) for motor systems and their components. The standard is divided into basic PCRs (core PCRs), common and basic rules for all components of the drive system and further product-specific rules (PSR), e.g. for converters, starters etc. The PSRs are designed to allow further product-specific simplification of the LCA, e.g. through differentiation between main

components, involving mandatory consideration, and auxiliary components, where consideration is voluntary due to low significance. These rules have to be applied in the LCA if the results are meant for external communication. They define certain parameters for all manufacturers to enhance the comparability and usability (in a system context) of declarations.

### **3 Application example: Centrifugal pump**

#### **3.1 Applied Methods**

##### **3.1.1 Life cycle assessment**

LCA is a method to quantify the environmental impact of products, systems and services over the entire life cycle in order to support sustainable development in organizations (a.o. [Hauschild et al., 2005; Brondi and Carpanzano, 2011; Pulselli et al., 2009]). The LCA was conducted according to the principles laid down in the international standards [ISO 14040:2006; ISO 14044:2006], as well as the ILCD handbook [ILCD 2010] and the above introduced product category rules for motor systems in [EN50598-3:2015]. The software SimaPro was used for the modelling of the material, manufacturing and disposal stage (Ecoinvent 3.0.1 library). For the use stage, the software SinaSave (version 6.0) was used, which is an online platform provided by Siemens [Siemens 2017]. SinaSave determines the energy saving potential and payback times based on particular application conditions. The tool offers a wide range of comparison options of various control modes and product combinations for drive systems for pump & fan applications. These are then graphically shown with their components as well as the most important results, for instance, the power losses according to EN50598. The results from SinaSave were then transferred into SimaPro, in order to get the overview of the whole life cycle, as well as determining the impacts.

##### **3.1.2 Life cycle costing**

An LCC is a comprehensive decision-making tool for calculating the total costs which are generated over the entire lifetime of products and services [Kádárová et al., 2015]. The execution of an LCC enables the potential cost drivers and cost savings of a product or service to be identified over its entire life cycle. By comparing different alternatives, the most cost-effective option can be identified. A variety of methods and approaches has been developed under the

umbrella of LCC, due to the heterogeneity of application scenarios of the businesses being analyzed. The common aim of the various LCC approaches is to determine the most cost-effective and thus economically most competitive solution of a product or service [Woodward 1997]. In this case, the LCC, consisting of CAPEX and OPEX (i.e. capital and operational expenditures, respectively), were derived by using a cost breakdown structure (CBS), taking into consideration the principles laid down by [Hui & Mohammed, 2015], in order to analyze the cost-benefit ratio in terms of the pay-off period. To calculate the LCC of the combined system, also SinaSave was used, with an underlying price of € 0.12 for one kWh of electric energy as an average value within the EU (Eurostat: EU-28; 2nd half of 2014) based on [EU 2015].

### **3.1.3 Eco-Care-Matrix**

The Eco-Care-Matrix (ECM) [Wegener et al., 2009; Wegener et al., 2011] is used as a decision-making support tool in portfolio management as well as product lifecycle management, including engineering. As a four-by-four matrix, it plots the ecological impact/benefits over economic performance of a product or system compared against a reference, for instance an outdated or an alternative technology. The application of ECM supports the development of products and services that have been improved from environmental and cost efficiency perspectives. The ECM can therefore be seen as an Eco-efficiency tool, including the challenges associated with the concept of Eco-efficiency, described by [Ehrenfeld 2005] and further introduced with applications by [Huppel & Ishikawa, 2007].

The results from LCA and LCC are used as basis to assess the environmental benefits over the economic benefits. While the x-axis represents customer benefit as a change in system costs, the y-axis expresses the potential environmental impacts of a considered application to the reference point. Environmental benefit can include a combination of any environmental impact.

The reference point (e.g. a traditional technology) is located at the center of the matrix. A technology/scenario then can be defined as “green solution”, if its environmental performance is better than the reference at the same (or better) level of customer satisfaction.

### 3.2 Case study

#### 3.2.1 Goal & scope

Examining the environmental and economic performance of two drive systems in two application scenarios (in terms of an operating profile) is the goal of this case study. Drive system 1 is a fixed-speed drive system and drive system 2 is a variable-speed drive system. Both drive systems consist of products within the Siemens product catalogue. Based on the lifetime of the frequency converter, the assumed lifetime of both drive systems is 15 years; both drive systems are manufactured and used within Germany. **Figure 12** shows the concept of the two drive systems and application scenarios.

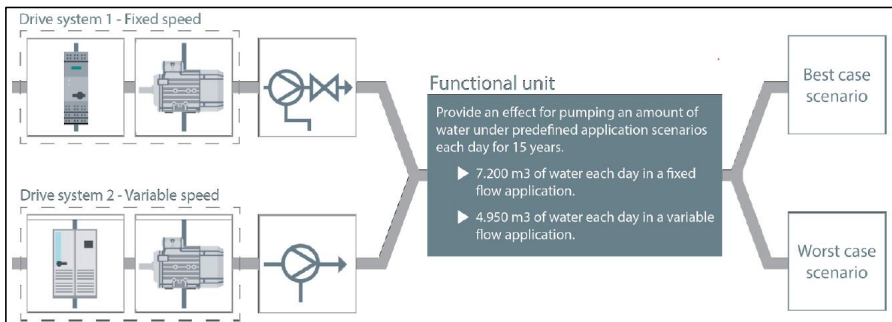

**Figure 12.** Graphical display of the case study concept including the defined functional units.

One application scenario is tested for a constant flow of 100%, while the other application scenario represents a variable flow of a pump. Drive system 1 with the fixed speed has an additional throttle to be able to control the flow from the pump. This is not necessary for drive system 2, since it already has a variable flow. As the pump, the throttle is also placed outside of

the system boundary. The settings of the pump application with the medium water were a pump head of 100 m (1 stage) and a flow rate of 300 m<sup>3</sup>/h, hence a nominal power of 132 kW has to be provided by the drive system.

For both scenarios the reference profile is assumed as 365 days and 24 hours of operation per day. The details in terms of operating hours at a specific flowrate are shown in **Table 2**.

**Table 2.** Two operation scenarios for pump applications in terms of operating hours per flowrate. These reference scenarios are basis for the case study. For both, the reference service life is 15 years, operating at 365 days per year and 24 hours per day.

	Flowrate [%]	10	20	30	40	50	60	70	80	90	100
1) Fixed Speed	Operating hours	0	0	0	0	0	0	0	0	0	24
2) Variable Speed	Operating hours	0	0	1	2	3	5	5	4	3	1

The corresponding functional unit chosen is:

- m<sup>3</sup> of water each day in a fixed flow application
- 4.950 m<sup>3</sup> of water each day in a variable flow application

As mentioned, SimaPro was used for the modelling of the material, manufacturing and disposal stage, if materials were differently defined or did not exist in the library, estimates were applied. The scope was determined from the extraction of raw materials to the disposal stage.

**Figure 13** exemplarily shows the modelling approach taken, and **Figure 14** shows the associated system boundaries for the drive systems by the model for drive system 1. The models will be similar for drive system 2, only substituting the soft starter with the frequency converter.

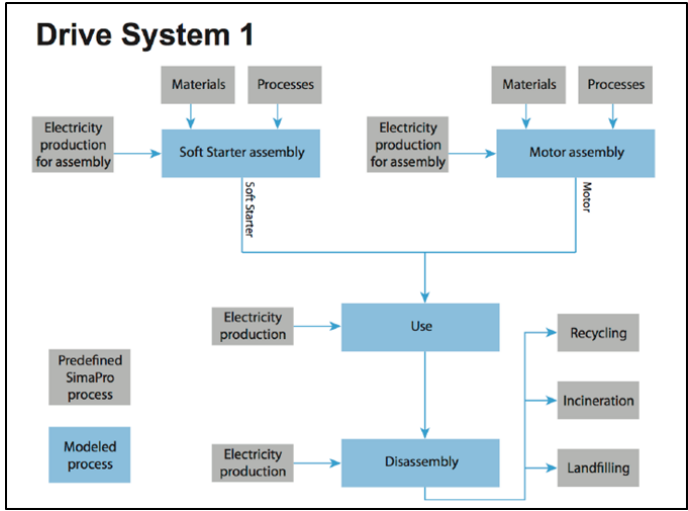

**Figure 13.** Complete modelling network of drive system 1.

The processes are divided into foreground processes (foreground system) and upstream- and downstream processes (background system). Regarding transport, all other transportation processes in the LCA have been neglected, based on the results of other comparable case studies [Auer et al., 2016; Auer et al., 2017], except the ones already included in the generic data sets of the selected materials and processes in the background system.

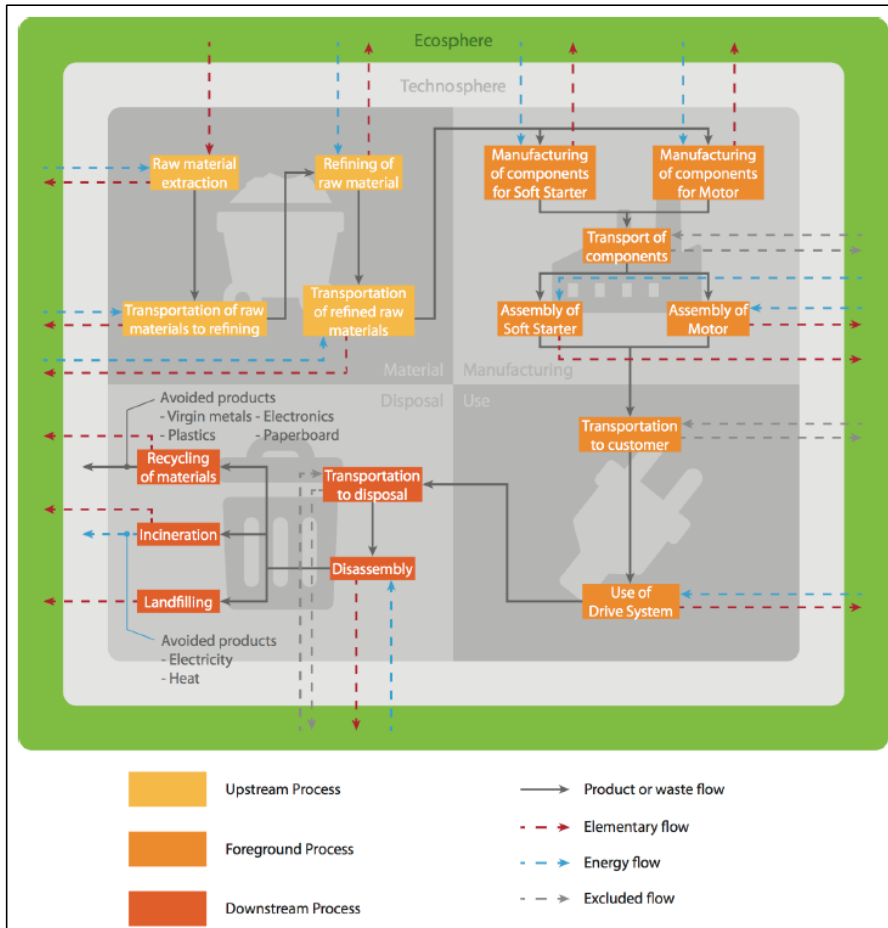

**Figure 14.** Model showing the system boundaries.

For the LCC, as mentioned SinaSave was used, reflecting current market prices for the systems set-ups. The integrated drive systems' components prices are current list prices (March 2017), energy cost are set to 0.12 €/kWh. Investment costs were assumed to be dominated by the cost for the components (e.g. motors) and therefore installation costs, as well as cost for maintenance, are expected to be comparable (no major difference between the systems) and are therefore not included.



### **3.2.2 Life Cycle Inventory**

*Material and manufacturing stage:* To simplify the modelling of the drive system components, a 1% weight based cut-off was applied. Manufacturer information, as e.g. the bill of material (BoM) including weight and material, was in the SimaPro model matched to the most typical processes available in the Ecoinvent database. The energy consumption for the assembly was allocated to the components, using working hours as allocation factor.

*Use stage:* As tool for calculating the power demand of the two drive systems in the two application scenarios SinaSave is utilized. In order to compare the two drive systems the required specifications have to be entered to demonstrate energy savings and CO<sub>2</sub> emission savings. The calculated power demand is used as input in SimaPro and corresponds to the electricity consumed in the use stage. The data is displayed in the following **Table 3**.

**Table 3.** Energy Consumption of the two drive systems in the applied usage scenarios (fixed speed, variable speed) per year and for the assumed service life of 15 years. Drive system 1, as basis for calculating the energy savings, is equipped with a soft starter and a throttle, drive system 2 with a variable speed drive.

		<b>Drive System 1: Fixed Speed Drive with IE3-Motor (FSD-IE3)</b>	<b>Drive-System 2: Variable Speed Drive with IE3-Motor (VSD-IE3)</b>
<b>Application Scenario 1: Constant flow, fixed speed</b>	Power Demand per year [kWh/a]	925,959	945,999
	Power Demand for 15 years [MWh]	13,889	14,190
	Difference in 15 years (DS1 – DS2) [MWh]	- 300.6 → DS1 performs better in this scenario	
<b>Application Scenario 2: Variable flow, variable speed</b>	Power Demand per year [kWh/a]	672,863	358,461
	Power Demand for 15 years [MWh]	10,093	5,377
	Difference in 15 years (DS1 – DS2) [MWh]	+ 4,716 → DS2 performs better in this scenario	

*Disposal:* The processes for end of life treatment have been chosen on the basis of common practices in Europe as reflected in the database of SimaPro.

### 3.2.3 Life Cycle Impact Assessment

The modelling in SimaPro, makes use of the Ecoinvent- consequential system and unit version 3.0.1 library and the ILCD 2011 Midpoint + version 1.06. The impact categories that are included in this method, as well as the normalization factors are presented in **Table 4**.

**Table 4.** Impact categories of ILCD 2011 Midpoint + version 1.06 with units and Normalization factors.

<b>Impact category</b>	<b>Abbreviation</b>	<b>Unit</b>	<b>Normalization Factor</b>
Climate Change	CC	kg CO <sub>2</sub> -eq	1.1E-04

Ozone Depletion	OD	kg FC-11	4.63E+01
Human Toxicity (cancer)	HTc	CTUh	2.71E+04
Human Toxicity (non-cancer)	HTnc	CTUh	1.88E+03
Ionizing Radiation, Human Health Effects	IR(HH)	kg PM2.5-eq	8.85E-04
Ionizing Radiation, Environment	IR(E)	kg Bq U235-eq	0
Photochemical Ozone Formation	POF	kg NMVOC-eq	3.15E-02
Acidification	A	mol H+eq	2.11E-02
Terrestrial Eutrophication	TE	mol N-eq	5.68E-02
Freshwater Eutrophication	FE	kg P-eq	6.76E-01
Marine Eutrophication	ME	kg N-eq	5.92E-02
Freshwater Ecotoxicity	FT	CTUe	1.14E-04
Land Use	LU	kg C deficit	1.34E-05
Water Resource Depletion	WD	m <sup>3</sup> water-eq	1.23E-02
Mineral, Fossil and Renewable Resource Depletion	RD	kg Sb-eq	9.9E-00

**Figure 15** now displays the external normalized scores in Person Equivalents (PE). The impact assessment shows that the impact categories with the highest impact scores are human toxicity (non-cancer effects), climate change and freshwater eutrophication. Comparing the two application scenarios by an assessment of the impacts, the preferable system is drive system 1 in application scenario 1 and drive system 2 for scenario 2.

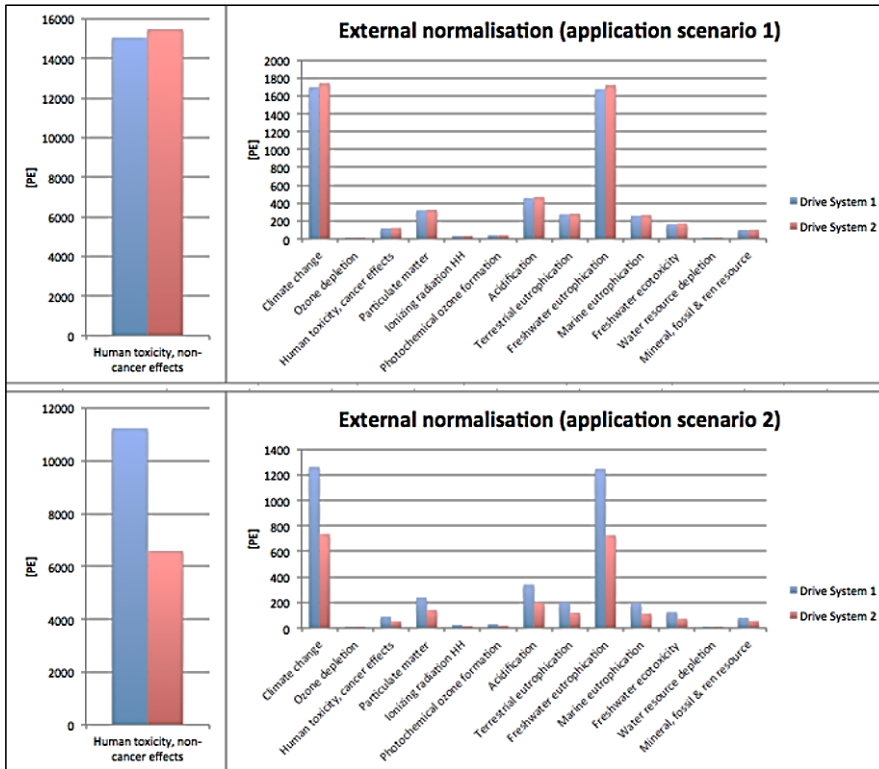

**Figure 15.** Normalized LCIA scores the two drive systems in the two usage scenarios. Human Toxicity is shown separately due to the scale.

### 3.2.4 Life Cycle Costing

**Table 5** summarizes the results of the LCC and it shows that in total the operational cost dominate the costing in both application scenarios. It also shows that in scenario 1, the drive system 1 performs economically better, about 3 % over the 15 years of assumed service life. In scenario 2 the drive system 2 performs economically better, by about 45 % over the 15 years of service life.

**Table 5.** Summary of the LCC of the two drive systems in the two application scenarios.

<b>Investment Cost</b>		<b>Drive System 1: Fixed Speed Drive with IE3-Motor (FSD-IE3)</b>	<b>Drive-System 2: Variable Speed Drive with IE3-Motor (VSD-IE3)</b>
	Motor	25,400 €	28,193 €
	Soft Starter	1,450 €	
	Frequency Converter		10,120 €
	Total	26,850 €	38,313 €
<b>Operational Cost - Scenario 1 (FS)</b>	Energy cost per year	111,115 €	113,520 €
	Energy Cost per 15 years	1,666,726 €	1,702,798 €
<b>Operational Cost - Scenario 2 (VS)</b>	Energy Cost [€/a]	80,743 €	43,015 €
	Energy Cost per 15 years	1,211,153 €	645,230 €

### 3.2.5 Interpretation & Discussion

*Material stage:* In the material stage the copper is responsible for most of the impacts followed by low-alloyed steel and cast iron, which are all components of the motor. The highest impact categories in this context are human toxicity, freshwater eutrophication and particulate matter.

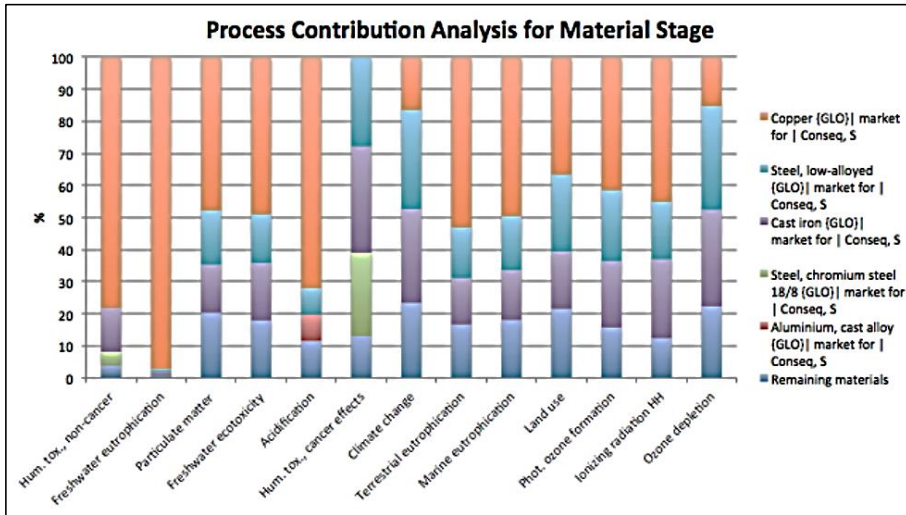

**Figure 16.** Process contribution analysis for material stage in %.

*Manufacturing stage:* The impact category human toxicity has a very high score, followed by mineral, fossil and renewable resource depletion and particulate matter. It can be seen in the process contribution analysis, that the casting of steel causes about 80-90% of the impacts in each category.

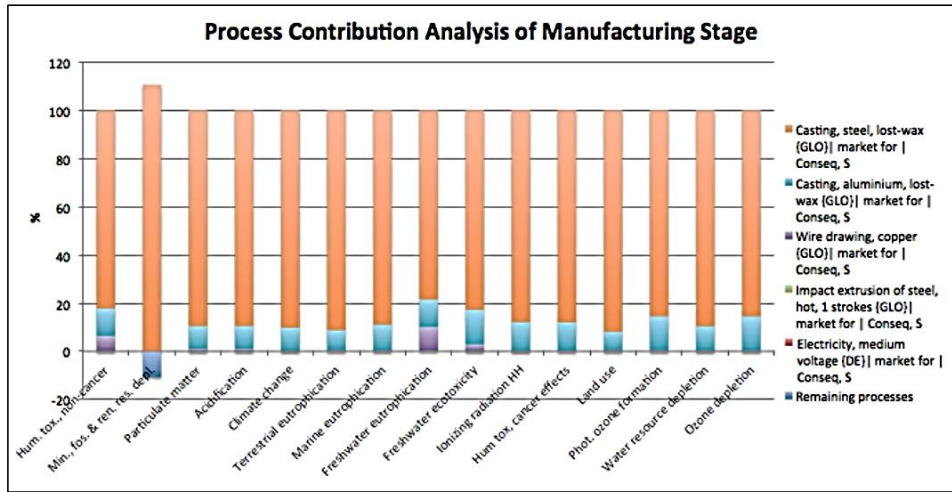

**Figure 17.** Process contribution analysis of manufacturing stage.

*Use stage:* The energy consumption (low voltage electricity, German grid mix) which runs the drive system and the connected pump is responsible for the vast majority of all impacts during the whole life cycle. Except mineral, fossil & renewable resource depletion, the use stage accounts for 97.1 99.9% of the impact in all categories.

*Disposal stage:* The process of copper scrap is the main driver (93%) behind the highest impact score of mineral, fossil and renewable resource depletion. The remaining impact categories have impact scores that are either negative or close to 0. The electricity consumption related to the disassembly of the products is the highest contributor in the majority of the remaining categories.

*Main contributors:* The energy consumption during the life cycle stage use stage is the major contributor to all impact categories, while the process of steel casting is the main contributor to the impact scores in all categories. The emission of carbon dioxide is the dominating elementary flow in climate change. Copper can be seen as the dominating factor regarding materials

originated from the motor. The main contributing impact categories are climate change followed by freshwater eutrophication.

*Life Cycle Costing*: LCC was approached in a very simplified manner, compared to [Auer et al., 2016] only taking into account today's components prices and the cost for energy consumed, not aspects as installation and maintenance costs or the development of the price for electricity and depreciation. The results of the LCC correlate to the LCA, in terms of PE and the impacts driven by electricity consumption.

It can be concluded that drive system 2 has the best overall environmental performance and is the preferred choice, when taking both application scenarios into account. In the application-specific view, drive system 1 performs marginally better in application scenario 1, and drive system 2 performs significantly better in application scenario 2. Human toxicity (non-cancer effects), climate change and freshwater eutrophication are the categories causing the highest impact scores. For most impact categories, about 97.1-99.9% of the impact comes from the electricity consumption in the use stage. The extraction of copper during the material stage is the most contributing process, while the steel casting process is dominating the manufacturing stage. Therefore, the reduction of the power demand of the drive system, resulting from a higher energy efficiency, is a major lever for the reduction of environmental impacts.

In the end, the results showed the significance of a system design optimized to the application needs concerning both the environmental as well as the economic performance.

### **3.3 Eco-Care-Matrix**

As explained in the methods section (chapter 3.1.3), the ECM visualizes the results from a LCA and a LCC in a matrix to support decision-making. For both applied use stage scenarios, the results will be displayed setting the Drive System 1 (FSD-IE3 = Fixed Speed Drive with IE3-



Motor; throttle control) as reference for the comparison with Drive System 2 (VSD-IE3 = Variable Speed Drive with IE3-Motor, Frequency Converter control).

### 3.3.1 Application Scenario 1: Constant Flow – Fixed Speed

Figure 10 now displays the ECM for the constant flow application with fixed speed, as the results explain in the previous section already indicated, the difference in percent-ages are marginal (2 – 3 %). In absolute values DS2 is about 50,000 € more expensive (39,000 in use stage over the 15 years, 11,000 in investment) and emits about 0.19 Mt more in CO<sub>2</sub>-eq (German electricity mix).

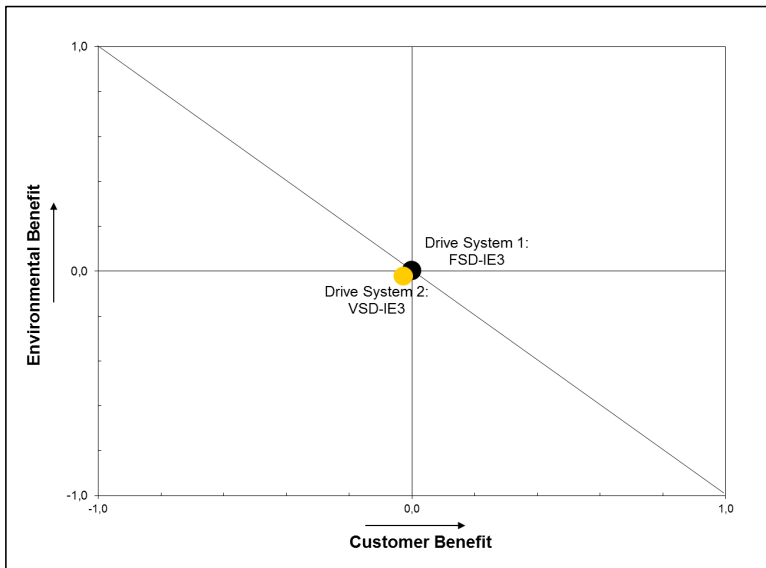

**Figure 18.** Eco-Care-Matrix of the two drive systems in the constant flow (continuous operation, fixed speed) application scenario.

### 3.3.2 Application Scenario 2: Variable Flow – Variable Speed

Based on discussion in the previous section (chapter 2.2) another drive system was added in this context. It's also a fixed speed drive system, as DS1, but utilizing an IE4-motor instead of

the IE3-motor as in the base case, and therefore will be referred to as DS1.1. Auer et al. [2017] already looked into comparing the environmental performance of motors with different efficiency classes, whereas in this case the goal was to quantify the potential performance increase on system level compared to the component level. Background data for the ECM is summarized in **Table 6**.

**Table 6.** Configuration and background data for Drive System 1.1 – A fixed speed drive with IE4-Motor (FSD-IE4) instead of the IE3-motor as in the base case.

		<b>Environmental data:</b>	<b>Economic data:</b>
<b>Materials &amp; Manufacturing stage; Investment cost</b>	Motor	3,773 kg CO2-eq	28,600 €
	Softstarter	180 kg CO2-eq	1,450 €
	Total	3,953 kg CO2-eq	30,050 €
<b>Scenario 2: Variable Speed Application</b>			
<b>Use Stage operational costs</b>	Energy Consumption [kWh/a]	667,286	
	Per year	421,724 kg CO2-eq	80,074 €
	in total over 15 years	6,325,871 tons CO2-eq	1,201,114 €

Figure 11 now displays the ECM for the variable flow application with fixed speed, as the results explained in the previous section already indicated; a significant improvement in economic and environmental performance can be achieved by the system design (i.e. by adding the frequency converter).

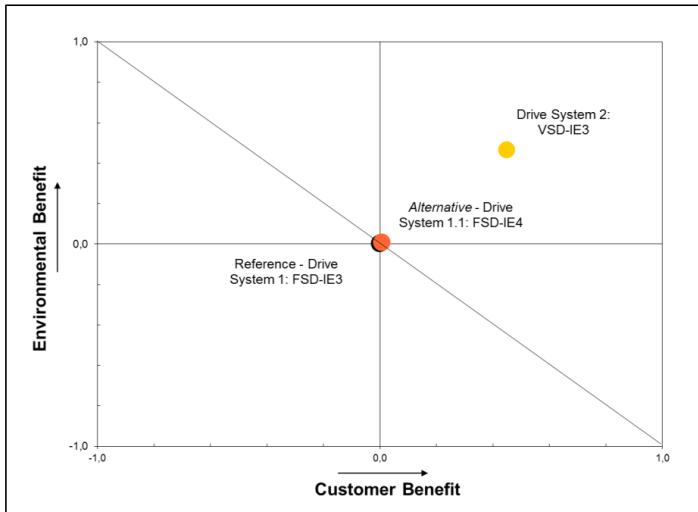

**Figure 19.** Eco-Care-Matrix of the two drive systems in the variable flow (variable speed) application scenario.

In percentages, the increase is about 45 % in both dimensions from DS1 to DS2. This corresponds to savings of about 550,000 € and 3 Mt of CO<sub>2</sub>-eq (German electricity mix). The related higher investment is easily compensated by the savings in the use stage; break-even of the investment was calculated to 3.6 months in this application scenario in SinaSave.

In comparison, the DS1.1 increases performance, environmentally and economically, only about 1 % compared to the reference set-up (DS1).

### 3.4 Summary of the application example

The previous sections show an example of applying the Extended Product Approach in a practice-close ecodesign decision situation covering cost and environmental impacts: A centrifugal pump system shall be selected based on two given operation scenarios, and options are to either use a fixed-speed drive or a variable-speed drive as core for the systems. The example demonstrates, that taking the extended system view can reveal that an option, which

may appear less preferable in a smaller system context, may well prove preferable in the extended system – both in terms of cost and environmental impact. The Eco Care Matrix proves well-suited as tool for making and visualizing two-dimensional comparisons, also for such extended systems.

Besides these positive observations, the EPA also entails a number of rather negative aspects, such as increased complexity. These are discussed critically in the following.

#### **4 Results & Discussion**

This paper deals with the 2015-released European standard EN 50598 on energy-efficiency of drive systems. This standard particularly addresses the very important but in previous standardization not covered aspect, that energy-efficiency should be assessed in application context and of complete drive systems, under an Extended Product Approach (EPA), and not “just” based on energy-efficiency of single components of the drive system, e.g. single motors, since system efficiency in applications cannot be deducted from efficiencies of single components, no matter how well such “classic” single-component approaches and related efficiencies may be described and standardized. For actually applying the EPA, key support elements provided by the standard are the concepts of load-time profiles and of operating points, at which the drive systems work in operation. This paper clearly explains this overall point and clarifies, by means of a wrap-up of historical developments and international contexts, why system efficiency in application context has not been addressed in a systematic international standard until now.

In addition, this underlines that the matter of ecodesign and standardization is very multifaceted. Thus, it yields several aspects potentially worth-while a discussion related to the EPA, for instance harmonization of horizontal (generic, cross-category) standards and vertical (specific, single-category) ones, or how to address electronic products (following their own

standardization paradigm), which are part of non-electronic products (following a different standardization). Yet, a main focus in this paper is on how to use the new standard, and in particular the EPA, in decision-making, and thus the discussion focuses on what implications the EPA may bring about that might hamper or ease decision-making.

On the one hand, the EPA as such adds complexity to the task as it advocates (i) taking an extended scope of what is to be analyzed and (ii) judging upon this in various application situations. Compared to earlier practice, this means more efforts (i.e. time and skills, as well as model/tool capacities for testing and documentation, etc.) for the practitioner, e.g. due to more data collection covering all elements of the larger system. Putting this then into the various application situations requires additional extra efforts. However, the guidance given in the standard appears clear and comprehensive enough to work with, as for instance, concrete system delimitations and operating points are provided (see fig. 3 and fig. 8 & 9) as well as the semi analytical models (SAM). After a certain run-in phase, the practitioner's extra efforts are expected to decrease substantially. On the other hand, the overall still somewhat higher efforts related to taking the EPA are considered fully justified by its very purpose as it enables decision-making in the appropriate larger context and thus eliminates common issues such as sub-optimizations, i.e. improvements of sub-parts of a system, which may be insignificant or even counterproductive in the larger system context. Both the efforts decrease and the avoided sub-optimization increase may be investigated in targeted empirical studies (based on cases as explained in this paper), which then may inform broad implementation efforts.

The outcomes of applying the EPA were shown in the example in Chapter 3 and proved that the approach can reveal decisive insights, not obtained when looking at system parts alone. A concrete example being that a drive system with a motor from a lower efficiency class (IE3)

turned out to be some 45% better performing in the environmental dimension (and in the economic dimension, too) than a comparable drive system using a higher efficiency class (IE4). This was shown in Figure 18 in context of the application scenarios analysed by means of the Eco-Care-Matrix (ECM). Apart from the concrete results, running scenarios with the ECM also showed that the ECM itself can be a powerful means to communicate results obtained through applying the EPA. Such an integration of the EPA in the ECM may be relevant in ecodesign projects to visually express quantitative comparisons of alternatives, both within project teams and to outside stakeholders.

A potentially huge influence of the EPA is seen in relation to its application within scope definition of LCAs. Practitioners or entire organizations may voluntarily choose to use the EPA as inspiration or internal standard procedure. However, if related ISO standards, e.g. ISO 14040 & 14044 on LCA, would be amended by a clear recommendation or even a requirement to adopt the EPA during the scoping phase of the LCA, a large shift in results and subsequent decisions can be expected (as shown in the scenarios presented here), both in industrial decision-making and in public policy-making. An amended recommendation or even obligatory adoption would require preceding standardization efforts, e.g. the development of guidance for other industries and applications than electric drive systems, wherever meaningful.

The EPA is particularly relevant to apply in the design stage of systems where potential power losses are key. Within the design stage, the EPA would help selecting suitable components, e.g. electric motors in drive systems. With regard to existing systems and installations, it is not considered a first priority to revisit and potentially recalculate related LCAs and other system performance values, even if EPA integration would become obligatory, since the systems are in operation. However, as soon as exchange of components in such running systems becomes

necessary, e.g. due to maintenance or failure, the EPA could show its influence on the decision (which may well be to replace with the same component as used before).

As stated earlier, application of the EPA on even larger systems than drive systems is judged meaningful. An exploration of such meaningful applications could start with larger electric systems, e.g. entire washing machines, to entire heating/cooling systems. It could also be used in design of indirectly energy-using systems such as windows (i.e. “energy-related products” as termed in [EU 2009]). It could also be applied to design decision-making only on well-defined levels of very large systems, e.g. production equipment. Regarding entire products, it may though show more meaningful to use the instrument of Ecolabelling, with generic criteria, rather than requiring individual specific assessments.

## **5 Conclusions & Outlook**

With the new standard series EN50598 for drive systems, issued in 2015, the first comprehensive and holistic ecodesign standard for drive systems has been developed and published in the context of standardization mandates issued by the European Commission relating to the ErP Directive. It defines an innovative approach to energy efficiency determination for converters and especially for drive systems in an application context through semi analytical models and the extended product approach. Manufacturers of power drive systems now have to evaluate losses at eight defined operating points and use the corresponding energy efficiency index. This information then has to be provided with the product documentation. System designers, selecting components, are then able to define the most efficient drive solution to the need of the application, based on the operating points and the associated losses. The corresponding case study applying the EN50598 standards series in a pump application context showed the benefits of the extended product approach in terms of environmental impact scores and the economic performance. The case study also showed that the

levers on system level regarding application specific design are higher than what is achievable on component level.

This is a beneficial situation for all stakeholders because the manufacturers of drive system components are able to design the products corresponding to the needs of the application, since the fundamental interface – between the components, the system and the application – is laid down. Thus, the system designer (of the extended product, i.e. the application) can easily design an efficient system, based on the available losses data and the environmental aspects of the manufacturing and end-of-life stage, and then – last, but not least – the final customer or user of the system can easily take these aspects into account when deciding on the investment.

The basic concept of this approach, based on the EPA and the underlying SAM, may be a concept also applicable in other (complex) product systems dealing with energy and/or resource efficiency in application context. Key success factor is an extensive collaboration of stakeholders of affected product systems and their applications, to define the relevant operating points and corresponding usage scenarios. Here the processes and work platform of standardization provides a proper set-up for facilitating these technical rules.

The standard also defines requirements for qualitative and quantitative environmentally-conscious design (ECD) processes and environmental product declarations. Furthermore, the standard introduces an LCA-based environmental self-declaration type, based on ISO 14021 and taking into account the basic requirements of ISO 14025, and it provides product category rules (PCR) for this. This holistic approach, from the initial ECD to the Environmental Product Declaration (EPD), utilizing and further detailing applicable horizontal standards from both the IEC and the ISO worlds of standards is also relatively new in product standardization of electronic and electrotechnical products and systems. The formulation of PCR, especially in the



contemporary discussions and developments on environmental footprints of products (e.g. the European PEF initiative), can be a robust foundation to the harmonization of these rules, because different EPD program operators (as required by the ISO 14025 for full Type III environmental declarations) or other institutions can rely on them, and manufactures, therefore, would be able to participate in these EPD programs without having to adapt their underlying LCA models and accompanying reports. On the other hand, the standardization process itself fulfils all aspects of the PCR development, e.g. consensus, stakeholder involvement, ball-out practice, as intended by the ISO 14025. Hence, when taken into account, these LCA-based self-declarations, i.e. EPDs developed according to the requirements of EN50598-3, e.g. process verification, do then fulfil most requirements of the ISO 14025 standard and therefore may be accepted by customers, without the label of a third-party EPD program. Manufacturers can choose their approach, or rather, can detail the corresponding processes according to their needs and strategy.

All in all, EN50598 displays only minor drawbacks, which are due to its very purpose, namely the systematic consideration of larger system contexts than just single components. These drawbacks are however by far outweighed by this standard's key capability to guide designers towards increased overall system performance and by its thoroughly developed three parts, which in a very concrete way support its application by practitioners and its integration into existing standardization and legislative frameworks.

## REFERENCES

[Auer et al., 2016] Auer J., Schäfer J.M., & Bey N.: Combined Life Cycle Assessment and Life Cycle Costing in the Eco-Care-Matrix: A case study on the performance of a modernized manufacturing system for glass containers. *Journal of Cleaner Production*. 2016;141:99-109. DOI: 10.1016/j.jclepro.2016.08.096

[Auer et al., 2017], Auer J., Meincke A.: Comparative Life Cycle Assessment of electric motors with different efficiency classes: A deep dive into the trade-offs between the life cycle stages in Ecodesign context. Submitted for publication.

[Boteler & Malinowski, 2015] Boteler R., & Malinowski J.: The Impact of the Integral Horsepower Amended Rule (1 – 500 HP Motor). Presentation at EASA 2015: U.S. Motor Efficiency Regulation Update. 23.04.2015

[Brondi and Carpanzano, 2011] Brondi, Carpanzano: A Modular Framework for LCA-Based Simulation of Production Systems, *CIRP Journal of Manufacturing Science and Technology*, Vol. 4 (3), pp. 305 – 312. (2011)

[CAPIEL 2016] European Coordinating Committee of Manufactures of electrical Switchgear and Controlgear (CAPIEL): Ecodesign Requirements for Electric Motors – Towards a System-Approach (Brochure).

[CEMEP 2015] European Committee of Manufacturers of Electrical Machines and Power Electronics (CEMEP): Energy-Efficiency with Electric Drive Systems. CEMEP (Brochure). Brussels, Belgium. (2015)

[CLC 2014] CENELEC: European Mandates, <http://www.cenelec.eu/aboutcenelec/whatwestandfor/supportlegislation/europeanmandates.html>.  
[Accessed on 27.06.2016](#)

[DIN 2016] Deutsches Institut für Normung: DIN in Europa. <http://www.din.de/de/din-und-seine-partner/din-in-europa>. Accessed 06.11.16

[EC 2014] European Commission, DG Energy, energy efficient products, electric motors, <https://ec.europa.eu/energy/en/topics/energy-efficiency/energy-efficient-products/electric-motors>, accessed on 27.06.2016 (2016)

[Ehrenfeld, 2005] Ehrenfeld: Eco-efficiency – Philosophy, Theory, and Tools. *Journal of Industrial Ecology*. 2005; 9(4):6–9.

[EN 50598-1:2015] EN50598-1:2015, Ecodesign for power drive systems, motor starters, power electronics & their driven applications - Part 1: General requirements for setting energy efficiency standards for power driven equipment using the extended product approach (EPA), and semi analytic model (SAM). (2015)

[EN 50598-2:2015] EN50598-2:2015, Ecodesign for power drive systems, motor starters, power electronics & their driven applications - Part 2: Energy efficiency indicators for power drive systems and motor starters. (2015)

[EN 50598-3:2015] EN50598-3: Ecodesign for power drive systems, motor starters, power electronics and their driven applications - Part 3: Quantitative eco design approach through life cycle assessment including product category rules and the content of environmental declarations. (2015)

[EPAAct 1992] Senate and House of Representatives of the United States of America in Congress assembled:Energy Policy Act 1992. Public Law 102-486-OCT. 24, 1992.

[EU 2009] Directive 2009/125/EC OF THE EUROPEAN PARLIAMENT AND OF THE COUNCIL of 21 October 2009 for establishing a framework for the setting of ecodesign requirements for energy-related products (recast). <http://eur-lex.europa.eu/legal-content/EN/ALL/?uri=CELEX%3A32009L0125>.

[EU 2014] Commission Regulation (EU) No 4/2014 of 6 January 2014 amending Regulation (EC) No 640/2009 implementing Directive 2005/32/EC of the European Parliament and of the Council with regard to ecodesign requirements for electric motors, OJ L 2, 7.1.2014, p. 1–2.

[EU 2015] [http://ec.europa.eu/eurostat/statistics-explained/index.php/Energy\\_price\\_statistics](http://ec.europa.eu/eurostat/statistics-explained/index.php/Energy_price_statistics). Accessed 08.10.2015

[Forsyth 1996] Forsyth A.: ISO 14001: What does it mean for IES? IIE Solutions. Jan. 1996;14-18.

[Hauschild et al., 2005] Hauschild, Jeswiet, Alting: From Life Cycle Assessment to Sustainable Production: Status and Perspectives. CIRP Annals – Manufacturing Technology. 2005;54(2):1–21.

[Hui & Mohammed, 2015] Hui, Mohammed: The Role of Cost Breakdown Structure in Life Cycle Cost Model. Jurnal Teknologi. 2015;74(2):117–121.

[Huppel & Ishikawa, 2007] Huppel, Ishikawa: An introduction to quantified eco-efficiency analysis, Eco-efficiency in industry and science, Vol. 22, Quantified Eco-Efficiency – An Introduction with Applications, Chapter 1, pp. 1 – 38, Springer Netherlands. (2007)

[IEC 2010] International Electrotechnical Commission: Welcome to IEC (brochure). Geneva, Switzerland. [http://www.iec.ch/about/brochures/pdf/about\\_iec/iec\\_welcome\\_en\\_2010\\_lr.pdf](http://www.iec.ch/about/brochures/pdf/about_iec/iec_welcome_en_2010_lr.pdf). Accessed 05.11.16

[IEC 60034-30-1:2014] IEC 60034-30-1: Rotating electrical machines – Part 30-1: Efficiency classes of line operated AC motors (IE code). (2014)

[IEC 62321:2008] IEC 62321: Electrotechnical products - Determination of levels of six regulated substances (lead, mercury, cadmium, hexavalent chromium, polybrominated biphenyls, polybrominated diphenyl ethers). (2008)

[IEC 62474:2012] IEC 62474: Material declaration for products of and for the electro-technical industry. (2012)

[IEC Guide 109:2012] IEC GUIDE 109: Environmental aspects – Inclusion in electro-technical product standards. (2012)

[IEC/CLC 2016] International Electrotechnical Commission (IEC), European Committee for Electrotechnical Standardization (CENELEC): IEC-CENELEC Frankfurt Agreement. (2016)

[ILCD 2010] European Commission - Joint Research Centre - Institute for Environment and Sustainability: International Reference Life Cycle Data System (ILCD) Handbook - General guide for Life Cycle Assessment - Detailed guidance. First edition March 2010. EUR 24708 EN. Luxembourg. Publications Office of the European Union.

[ISO 14006:2011] Environmental management systems – Guidelines for incorporating ecodesign. (2011)

[ISO 14020:2000] ISO 14020: Environmental labels and declarations - General principles. (2000)

[ISO 14040:2006] ISO 14040:2006, Environmental management - Life cycle assessment - Principles and framework (2006)

[ISO 14044:2006] ISO 14044: 2006, Environmental management - Life cycle assessment - Requirements and guidelines (2006)

[ISO 2012] International Standardization Organisation (ISO): Environmental labelling and declarations – How ISO standards help (Brochure). Geneva, Switzerland. ISBN 978-92-67-10586-4. (2012)

[ISO 2015] International Organization for Standardization: ISO in brief (brochure). Geneva, Switzerland. ISBN 978-92-67-10637-3. (2015)

[ISO 2016] International Organization for Standardization: ISO Strategy 2016-2020 (Brochure). Geneva, Switzerland. ISBN 978-92-67-10638-0.

[ISO Guide 64:2008] ISO Guide for addressing environmental issues in product standards. (2008)

[ISO/CEN 1991] International Organization for Standardization (ISO), European Committee for Standardization (CEN): Agreement on technical co-operation between ISO and CEN (Vienna Agreement). 1991

[Jugend et al., 2016] Chiappeta Jabbour Ch. J., de Souza F. B., Jugend D., Luiz O. R, Rojas Luiz J. V.: Ecodesign field of research throughout the world: mapping the territory by using an evolutionary lens. Scientometrics. 2016;109:241-259.

[Kádárová et al., 2015] Kádárová, Kobulnicky, Teplicka: Product Life Cycle Costing. Applied Mechanics and Materials. 2015;81(6):547–554.

[Pigosso et al., 2015] McAloone T. C., Pigosso D. C. A., Rozenfeld H.: Characterization of the State-of-the-art and Identification of Main Trends for Ecodesign Tools and Methods: Classifying Three Decades of Research and Implementation. Indian Institute of Science. 2015;94:405-427.

[Pulselli et al., 2009] Pulselli, Ridolfi, Rugani, Tiezzi: Application of life cycle assessment to the production of man-made crystal glass. International Journal of Life Cycle Assessment. 2009;14:490–501.

[Rondinelli & Vastag 2000] Rondinelli D., & Vastag G.: Panacea, Common Sense, or Just a Label? The Value of ISO 14001 Environmental Management Systems. European Management Journal. 2000;18(5):499–510.

[Siemens 2017] Siemens: SinaSave. Tool for calculating energy-savings and amortization of drives. <https://www.automation.siemens.com/sinasave#/en/home>. Accessed 13.04.2017.

[Thomas 2012] Thomas A.: Fixed Speed Drives – Energy Efficiency. Special print from etz special edition S4/2011. Siemens AG, Fürth, Germany, 2012. Order No. E20001-A250-P301-X-7600.

[Wegener et al., 2009] Wegener, Finkbeiner, Geiger, Olsen, Walachowicz: Comprehensive Approach to Energy and Environment in the Eco Care Program for Design, Engineering and Operation of Siemens Industry Solutions. RISO International Energy Conference 2009. pp. 45-

[Wegener et al., 2011] Wegener D., Finkbeiner M., Holst J-C., Olsen S. I., & Wala-chowicz F.: Improving Energy Efficiency in Industrial Solutions – Walk the Talk. In Energy Systems and Technologies for the Coming Century: Proceedings. Risø International Energy Conference. 2011:187-196. (Denmark. Forskningscenter Risoe. Risoe-R; No. 1776(EN)).

[Woodward 1997] Woodward: Life cycle costing – theory, information acquisition and application. International Journal of Project Management. 1997;15(6):335-344.



**C-I: COMPARISON OF TWO DIFFERENT APPROACHES  
FOR A SIMPLIFIED LIFE CYCLE ASSESSMENT OF  
ELECTRONICS**

LECTURE 3.1.2., CARE INNOVATION 2014 CONFERENCE, VIENNA.

# COMPARISON OF TWO DIFFERENT APPROACHES FOR A SIMPLIFIED LIFE CYCLE ASSESSMENT OF ELECTRONICS

Johannes Auer<sup>a</sup>, Anja Zintl<sup>b</sup>, Burkhard Berninger<sup>b</sup>, Niki Bey<sup>c</sup>

<sup>a</sup> *Department for Environment, Health & Safety, Industry Sector, Siemens AG, Germany*

<sup>b</sup> *Department of Mechanical/Environmental Engineering, University of Applied Sciences Amberg-Weiden, Germany*

<sup>c</sup> *Department of Management Engineering, Technical University of Denmark, Kongens Lyngby, Denmark*

↙

↙

↘

**Abstract:** In order for life cycle assessment [LCA] and environmental footprinting to become widely established in practice in the electronics industry as a quantitative eco design approach, they needed to be implemented and applied in an effective way. The goal of this study was to reduce the necessary time and expenditure when matching the components to the references in the life cycle inventory for these types of products. Based on previous life cycle assessment case studies of converters, two different approaches of simplifying the evaluation of potential environmental impact using LCA for the assembled printed circuit boards [APCB] were compared in terms of possible accuracy and the costs involved. One approach was to build an application-specific reference APCB and linearly approximate the environmental impact. The other approach was based on reducing the components to the most significant ones to reduce the expenditure required for matching within the life cycle inventory.

↙

↘

↙

↘

## 1. INTRODUCTION

“Footprinting” has become more and more popular in recent years, from declaring the environmental carbon footprint for products to Europe’s environmental footprint methodology, just recently developed by the European Commission’s Joint Research Center (JRC IES) [1]. Common basis for all is the underlying life cycle assessment (LCA) to evaluate potential environmental impacts over a product’s defined life cycle, standardized in the ISO 14040/44 standards. Although an increase in transparency on environmental issues is basically beneficial for all stakeholders, various questions in the methodologies itself, their applicability and the support of associated goals, like resource efficiency [2], still remain unsolved in a global business environment. Key issues for instance include:

- how to tackle complex global supply and manufacturing chains, and to what extent
- how good and accurate is the data quality of generic life cycle inventory databases
- and finally – how to tackle the application aspect to support ecodesign efficiently.

The main points involved here are the consistency of assessment rules, known as product category rules (PCR), in the footprinting context and acceptable simplifications in the LCA to minimize costs or to focus on the major ecodesign topics respectively [3]. Especially the assessment of the potential environmental impacts of electronics, from the components to the assembled printed circuit board (APCB), is a tedious process.

Based upon extensive life cycle assessment studies on frequency converters, this study now aims to evaluate options to reduce the costs needed to assess these for the purpose of providing environmental footprints.

## 2. LIFE CYCLE ASSESSMENT OF FREQUENCY CONVERTERS

### 2.1. General

Adjustable speed drives (ASD) or variable-speed drives (VSD) are used to control the speed of machinery. Many industrial processes such as assembly lines must operate at different speeds when producing different products. Where process

conditions require that the flow of a pump or fan must be adjusted, varying the speed of the drive may also save energy when compared with other techniques for controlling flow. Frequency converters are devices that can be used to vary the speed of machinery. Figure 1 shows some device types for different applications in sizes ranging from small ones through booksize formats to whole cabinets with weights varying from several kilos up to several tons [4].



**Figure 1: Frequency converters for variable-speed operation in different sizes for different applications**

As mentioned before, ISO 14040 standardized the life cycle assessment methodology, which is defined as the "compilation and evaluation of the inputs, outputs and the potential environmental impacts of a product system throughout its life cycle" [5]. The basic steps, performed iteratively, are illustrated in Figure 2:

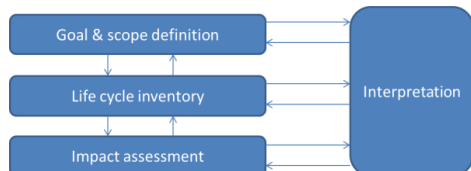

**Figure 2: Illustration of the iterative steps of LCA**

Therefore, these steps will form the structure of the rest of this chapter.

### 2.3. Goal and scope

The goal of the LCA study was basically to evaluate the most relevant life cycle stage and the associated driver, – e.g. component – and category in terms of environmental impact. In a second step, the study should provide eocdesign options and form the basis for environmental declarations.

The functional unit for the study was defined as one device providing a defined amount of power, e.g. torque-generating current. In this case study, these

are frequency converters for motor-driven applications in the booksize format with nominal currents of 3 A, 30 A and 200 A.

The system boundaries were set corresponding to a cradle to grave approach, starting from resource extraction to the final end of service life, recycling and disposal, including all of the associated follow-up processes. In the detailed manufacturing workflow this includes all processes from raw material extraction, part and component manufacturing, soldering and coaching the APcB up to the final assembly. To assess the use phase, a service life of fifteen years, 5000 operating hours per year and 100 percent load at all times, was assumed based on product-specific rules for variable-speed electric drives issued by the International EPD system [6]. Corresponding power consumption, including losses, was taken from data sheets. The assessment of the end of service life stage was based on IEC/TR 62635, including the recycling quotes for the various material classes.

The LCA did not take into consideration transportation to the site, the process of manufacturing the packing (just the material itself was included) and the manufacturing overhead, such as the building and associated energy usage.

GaBi4 software with DfX functionality and the GaBi professional and electronic extension database, provided by PE International, was used for the LCA.

### 2.4. Lifecycle inventory

Basis for the impact assessment and the corresponding impact indicators, e.g. kg CO<sub>2</sub>e, which must be included with the environmental declaration, is the life cycle inventory that is illustrated in Figure 3.

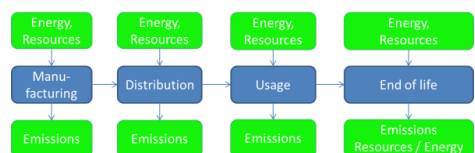

**Figure 3: Illustration of the life cycle inventory**

The corresponding parameters and data sources are summarized in Table 1. The analysis of supply chain data lead to well-founded estimates concerning transport and distribution.

**Table 1: Summary of life cycle stages, the corresponding parameters and data sources for the life cycle assessment**

	<i>Parameters</i>	<i>Sources</i>
Upstream	Transport distances & modes	Estimates based on Siemens AG suppliers' data
Manufacturing	Materials, weights, energy consumption	Product life cycle management, GaBi database, measurements
Distribution	Weight, transport distance	Estimates based on data from Siemens AG
Usage	Load profile, energy consumption,	Product datasheets
End of life	Materials, recycling and recovery processes	Generic data from GaBi database, IEC TR, discussion with recycling company

The product was not allocated, as this manufacturing workflow involving soldering and assembly generates no side products.

## 2.5. Impact assessment

In the impact assessment we considered the following impact categories, based on the CML2001 characterization model from December 2007:

- Abiotic (resource) depletion potential (ADP),
- Eutrophication potential (EP),
- Human toxicity potential (HTP),
- Photochemical ozone creation potential (POCP),
- Global warming potential (GWP) and
- Acidification potential (AP).

## 2.6. Results

By comparing the individual impact indicators using normalization, it was concluded that the most significant categories are GWP, AP and ADP. Results are listed and described in terms of the GWP as being representative for the conclusions in the

following. Based on the impact assessment it can be seen that the most relevant life cycle stage is the use stage, which is of no surprise when it comes to drive technology. This is shown in terms of the GWP (kg CO<sub>2</sub>e) in Figure 4.

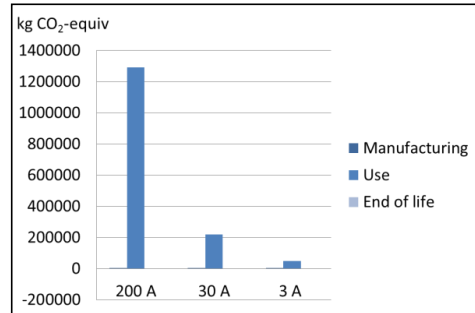

**Figure 4: Distribution of environmental impact, CO<sub>2</sub>e, over the life cycle stages. Use phase has the highest contribution to the impact. The columns of the other two phases are not visible due to the scale.**

However, it has to be taken into consideration that it makes no sense to assign the whole power consumption to the frequency converters, as the device just supports a motor in converting electrical power into mechanical power for a certain application. Therefore, Figure 5 shows the distribution when only considering the losses in the use phase, shifting the distribution in between the life cycle stages and depicting the significance, especially for the smaller devices for 30 A and 3 A applications. For these devices, the potential impact of manufacturing is very close to the impact associated with use.

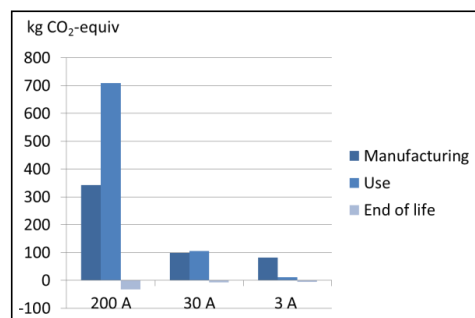

**Figure 5: Distribution of environmental impact, CO<sub>2</sub>e, over the life cycle stages. Here, the use phase just considers the losses.**

Having assessed the impact with a use case of 100 percent load the whole time, which essentially is

not the perfect operating profile to use a frequency converter [8], a more specific load-time profile (percentage of time at defined operating points), corresponding to pump applications, was analysed. This is shown in Table 2.

**Table 2: Application specific load-time profile, based on pump applications**

Operating point	Percentage of time [%]	Load [%]
1	6	100
2	15	75
3	35	50
4	44	25

The losses are then calculated as follows:

**Equation 1: Formula for calculating electrical power consumption (incl. losses) for a load-time profile based on [7]**

$$P_{\text{Electrical}} = \sum_{i=1}^n (\text{percent of time} \cdot P_i)$$

The application specific assessment of the device's use phase based on the load-time profile results in a reduction of losses of about 20 % compared to the initial scenario with 100 % load all the time. Concerning environmental impacts in terms of GWP, this leads to a "reduction" of about 17600 kg CO<sub>2e</sub> over the standardized lifetime of 15 years. This is quite considerable compared to manufacturing with a contribution of about 350 kg CO<sub>2e</sub> to the total GWP over the life cycle.

Another issue now looked at concerning use phase was "oversizing" of the device. Losses in frequency converters are primarily related to the losses in the power semiconductors (e.g. IGBT, thyristors), therefore using higher rating semiconductors means lower losses in switching and frequency modulation. The specific case looked at was using a 45 A device for a 30 A application. In the described use case, this reduces the power consumption and the related environmental impacts by about 1 % and in terms of GWP in absolute figures about 4500 kg CO<sub>2e</sub>. Still a good value compared to the necessary additional impact in manufacturing (30 A compared to a 45 A) of about 40 kg CO<sub>2e</sub>.

After having investigated the distribution of environmental impacts over the life cycle stages and a detailed look at certain aspects of usage, the manufacturing in regards to the contribution of the device's components to the environmental impacts was analyzed in detail. Figure 6 shows the distribution in terms of the GWP of the manufacturing stage.

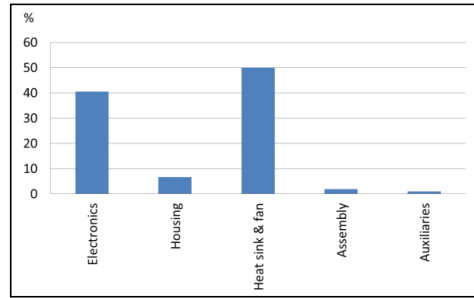

**Figure 6: Contribution of frequency converter components to the GWP of the manufacturing phase in percent.**

The figure shows that the electronic (APCBs and power electronics) and cooling components (heat sink and fan) contribute about 90 % to the GWP of manufacturing.

## 2.7. Conclusions

Based on the results of the detailed life cycle assessment of frequency converters, the following conclusions were drawn. The most relevant impact categories are acidification, (abiotic) resource depletion and the global warming potential, showing similar trends in terms of eco design measures or sensitivity analysis. Therefore, GWP can be used as a lead indicator when optimizing, whereas ADP still has to be looked at too. Concerning the distribution of environmental impact over the life cycle, the use stage has the highest impact when the total power consumption over 15 years usage is considered. Looking at it from the system perspective and only assigning the impact related to the devices' losses, shift this view to a domination of the manufacturing stage up to devices with a nominal current rating of about 30 A. Further, the study showed the necessity of considering and even focusing on the application aspects in ecodesign by comparing a "bad" system design (using a frequency converter for a fixed speed application at 100 % nominal current) to an application-specific system design (pump application with a defined load-time profile). It was also seen that in most cases, "oversizing" devices makes sense environmentally to minimize losses. In terms of manufacturing, the main contributors to the environmental impact are the electronic (APCBs and power semiconductors) and the cooling components (heat sink and fan).

### 3. SIMPLIFIED LIFE CYCLE ASSESSMENT OF ELECTRONICS

#### 3.1. General

As shown in Chapter 2, the environmentally most relevant contributors of frequency converters in manufacturing are the electronic and the cooling components. The electronic components are essential for the device functions and complex to assess in detail from an environmental perspective. Based on this conclusion, the idea came up to simplify the life cycle assessment for these components. To do this, the device components were assigned to groups and subgroups, shown in Table 3, focusing on the “electronics”.

**Table 3: Clustering frequency converter components into groups (“mechanical”, “electronics”) and subgroups (“APCB”, “PE”)**

Mechanical			
• Housing		• Cooling (heat sink and fan)	
Electronics			
Assembled Circuit Board(s) (APCB)	Printed Circuit Board (PCB)	Power Electronics (PE)	
• Printed Circuit Board (PCB)		• IGBT module	
• Components		• Shunt module	

#### 3.2. Basic framework and evaluation methodology

To quantitatively evaluate the applicability and benefit of a simplified LCA approach, it has been decided to weigh the accuracy of the simplified impact assessment (compared to a detailed approach) against the savings in working hours per model. In order to understand the following, it is necessary to describe the detailed modeling of the electronics using PE International’s Gabi DFX. This includes the electronic extension database and component mixer, which comprise the basic steps listed in Table 4.

**Table 4: Basic steps of detailed electronics modeling in Gabi with the electronic database and component mixer**

Step	Description	Remark
1	Extraction of bill of materials (BoM)	BoM from electronic data management (EDM) tool
2	Additional information gathering	For example, solder paste and process
3	Editing of BoM as preparation for next step	Formatting and editing the gathered information for further use
4	Matching and scaling	Matching the “real” components to the reference components available in the Gabi database and assignment of a scaling factor
5	BoM-Import	Transferring the related information into the life cycle inventory in the Gabi component mixer

In this workflow step 4, matching and scaling the individual components to the reference data in the database is the most resource consuming. Therefore, the main focus of simplification was to eliminate or simplify this step analogously to the “electronic” subgroup APCB.

Based on these steps a formula was developed, shown as Equation 2, to calculate the time required.

**Equation 2: Calculation of the time for LCA**

$$E = t_B + (x \cdot t_{ID}) + (y \cdot t_{ac}) + (z \cdot t_t) + t_b$$

With:

E = Effort [h];

x = Quantity of ID numbers [-];

y = Quantity of additional components [-];

z = Quantity of PCBs [-];

t<sub>B</sub> = Time to create a bill of materials for the electronics [h];

t<sub>ID</sub> = Time to assess the equivalent GaBi-processes per ID [h];

t<sub>ac</sub> = Time to assign the data per component [h];

t<sub>t</sub> = Time for data transfer to GaBi [h];

t<sub>b</sub> = Time for impact assessment [h].

For the 3 A and 200 A devices (lowest and highest complexity in the product family) the total time for creating an LCA without simplification was

calculated based on evaluated parameters. The results are shown in Table 5.

**Table 5: Time in hours for detailed life cycle assessment**

Device	Time for LCA [h]	Remark
3 A	44	$t_B = 1$ h; $t_{ID} = 0.16$ h; $t_{ac} = 0.25$ h; $t_i = 1$ h;
200 A	60	$t_b = 0.083$ h;
Average	52	Mean value of both devices

Based on this, we set the 52 h as average value for each LCA required for the following calculation of the benefit.

To evaluate the applicability of the simplification approaches, the values in terms of impact categories provided by the simplified approach to the “real” values from detailed life cycle assessments approach were compared. For this comparison the categories Global Warming Potential [GWP], Abiotic Depletion Potential [ADP], Acidification Potential [AP] were chosen as the most significant and representative.

### 3.2. Approach

Two approaches to simplify the LCA of the electronics were identified. One approach is to build up a reference group for the electronics and to analyze whether a (linear) approximation of the environmental impact through a certain device related parameter, such as the PCB area or rated output current, is possible. The other approach is based on reducing the components to the most significant ones to reduce the time it takes to match and scale all components within the life cycle inventory.

#### 3.2.1. Reference groups

In a first step, the environmental impact of the “electronic” group of 3 A, 85 A and 200 A devices were assessed and plotted against the parameters PCB area and nominal output current in a diagram. Further, a function was derived via linear approximation to describe the trend. Based on [3] we set a coefficient of determination ( $R^2$ ) to be higher than 0.97 as a minimum requirement when further considering the applicability.

The results of correlating the impact to the “electronic” group with the PCB area are shown as example for GWP in Figure 7. The summary of the coefficient of correlation of the derived functions for the individual impact categories is shown in Table 6.

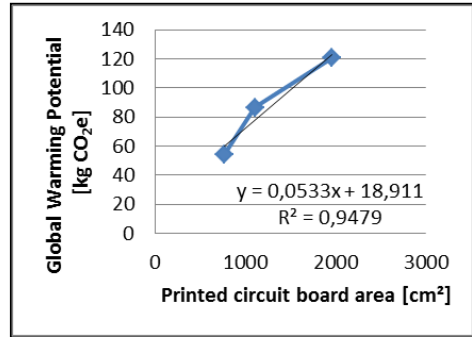

**Figure 7: GWP for the electronics of 3 A, 85 A and 200 A devices with respect to the PCB area with the derived linear approximation**

**Table 6: Summary of coefficients of determination for the linear approximation of environmental impact of “electronic” with respect to the PCB area**

Category	Coefficient of determination $R^2$
GWP	0.9479
AP	0.957
ADP	0.8497

It can be seen that in this case none of the functions’ coefficient of correlation matches the defined criteria.

In a second step, the same approach now was performed just for the subgroup APCB. The results are illustrated in Figure 8 for GWP and in Figure 9 for ADP.

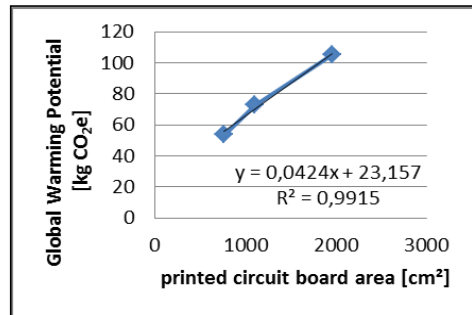

**Figure 8: GWP for APCBs of 3 A, 85 A and 200 A devices with respect to the PCB area with the derived linear approximation**

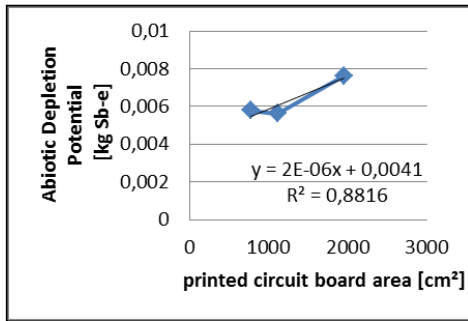

**Figure 9: ADP for APCBs of 3 A, 85 A and 200 A devices with respect to the PCB area with the derived linear approximation**

As it can be seen in the two graphs, as well as in the summary of the coefficients of determination in Table 7, this approach seems to work better than the first attempt considering the complete “electronic” group and all  $R^2$  values for the various environmental impact classes match the defined criteria yet again for ADP.

**Table 7: Summary of coefficients of determination for the linear approximation of environmental impacts with respect to the PCB area**

Category	Coefficient of determination $R^2$
GWP	0,9915
AP	0,9955
ADP	0,8816

Concerning nominal output current the group “electronics” (APCB and power electronics) was considered. The results are illustrated in Figure 10 for GWP and in Figure 11 for ADP.

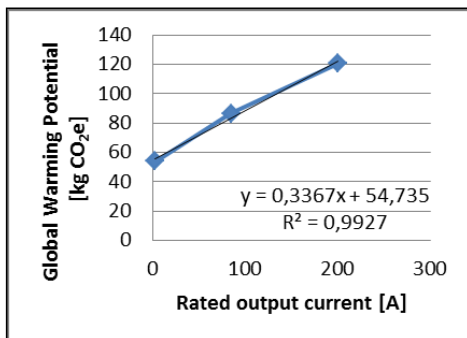

**Figure 10: GWP for APCBs of 3 A, 85 A and 200 A with respect to the nominal output current with the derived linear approximation**

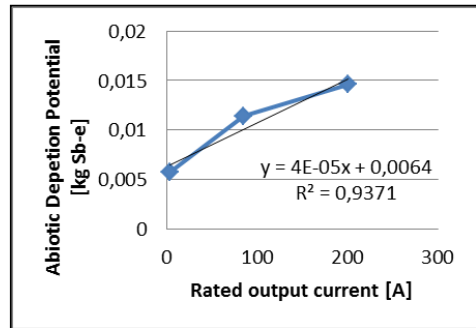

**Figure 11: ADP for APCBs of 3 A, 85 A and 200 A devices with respect to the nominal output current with the derived linear approximation**

Again, it can be seen in the two graphs, as well as in the summary of the coefficients of determination in Table 8, that this approach seems to work well for all impact categories but ADP.

**Table 8: Summary of coefficients of determination for the linear approximation of environmental impacts with respect to nominal output current**

Category	Coefficient of determination $R^2$
GWP	0,9927
AP	0,9959
ADP	0,9371

Comparing these two parameters after the first evaluation of linearity of the approximation, it appears that the nominal output current approach works better in terms of simplification than the PCB area.

Now the environmental impacts (GWP, AP and ADP) of different devices, with a nominal output current of 2x18 A (double-axis module) and 132 A were calculated using the functions that have been derived (parameter PCB area considering just subgroup APCB, nominal output current considering the “electronic” group) and compared with the “real” environmental impacts of these groups evaluated with a detailed LCA study (where components are precisely matched). Additionally, a device belonging to a different but comparable frequency converter product family, called FSC, was also considered to see if the function would also fit here. The results are summarized in Table 9.



**Table 9: Comparison of environmental impact derived using a simplified LCA approach and using a detailed assessment. A negative value indicates that the calculated value is higher than the value evaluated by a detailed assessment**

Product	Printed circuit board area [cm <sup>2</sup> ]	Relative deviation (GWP) [%]	Relative deviation (ADP) [%]
2x18 A	~ 1000	0.30	13.67
132 A	~ 2000	-6.88	1.29
FSC	~ 1000	2.18	-26.51
Product	Rated output current [A]	Relative deviation (GWP) [%]	Relative deviation (ADP) [%]
2x18 A	36	4.14	-4.16
132 A	132	15.13	19.79
FSC	32	2.47	-45.31

Looking at these figures it can be seen that the results derived by the function are more or less fitting for all impact categories (with GWP as lead) but ADP, taking into account a deviation up to 15 % with resulting values higher or lower than in a detailed assessment.

### 3.2.2. Reference components

The basic idea behind this approach was to analyse electric component categories regarding their contribution to environmental impact and then cut-off certain groups with very low values to reduce the time when matching and scaling. GWP was chosen as reference impact category to evaluate the electronic components. The groups with the highest Global Warming Potential are soldering pastes and printed circuit boards followed by integrated circuits (IC) and ring core coils. The group IC includes components with very high but also lower values. Groups with lower Global Warming Potential are basically diodes, coils, varistors, thermistors, quartzes, resistors, filters and switches. Other groups such as LEDs, transistors and capacitors include components with high and low GWP as a result of the different types and sizes. In summary, it was not possible to define groups to be cut-off in general to shorten matching and scaling times. Therefore a cut off criteria of 0.0362 kg CO<sub>2</sub> equivalent was chosen more or less randomly based upon the data analyzed.

All electronic components below the cut-off threshold were removed from the LCA models of the electronics of the products 3 A, 85 A and 200 A followed by a new impact assessment. These results were then compared to the results of the initial detailed assessment. The results are shown in Table 10.

**Table 10: Comparison of the results of a simplified approach by cutting off all electronic components with a potential impact below 0.0362 kg CO<sub>2</sub>e versus the results of a detailed assessment**

		Relative deviation [%]	Difference [kg CO <sub>2</sub> e]
3 A	Electronics	-13.69	7.37
	Whole product	-7.71	
85 A	Electronics	-7.56	6.55
	Whole product	-2.89	
200 A	Electronics	-7.32	8.83
	Whole product	-2.63	

Initially clear and also shown through the numbers is that through cutting off certain components the impacts will decrease. Generally, the deviations here range from around 3 to nearly 8 percent in the context to the figures resulting out of an assessment of the complete devices, which seems to be manageable.

As a consequence, in a next step, we decided to add a standard addition of 15 % to the impact categories to compensate for any cut-off components. Results are summarized in Table 11, showing that this solves the issue of reducing potential environmental impact by cutting off components, but adds additional impact up to 11 kg CO<sub>2</sub>e depending on the device.

**Table 11: Comparison of the results of a simplified approach (cut-off electronic components below 0.0362 kg CO<sub>2</sub>e) including a compensation value of 15 % versus the results of a detailed assessment**

	Differences [kg CO <sub>2</sub> e]	Relative deviation [%]
3 A	0.83	1.54
85 A	7.59	8.76
200 A	10.91	9.04
	Differences [kg Sb-e]	Relative deviation [%]
3 A	0.0002	3.27
85 A	0.0013	11.81
200 A	0.0016	11.16

This data now shows that the approach (selected components and standardized compensation value) is basically applicable, also for ADP, but the data derived tends to be higher than those derived by performing a detailed assessment.

### 3.2.3. Benefit evaluation

As described earlier, the applicability was evaluated based on the deviation of values and the benefit based on the saving of resources in terms of hours per assessment of a product family. Both parameters in this equation are assessed very individually and do have a high level of deviation in between the values stated by LCA practitioners. In this case, we evaluated our values based on interviews with 3 different practitioners with low up to high levels of experience. Then a scenario of providing information on product-specific environmental aspects, e.g. through an environmental product declaration for 6 different products within a product family was defined. Therefore, the basis for evaluation is 6 times the 52 hours for a detailed evaluation of each device, 312 h in total.

For the approach with reference APCBs, 3 times the 52 hours was calculated and 1 additional hour added for deriving the function for approximation and calculating the data for the other 3 devices. The total was 157 h.

For the approach using just selected components 17 hours mean value per assessment was calculated, resulting in a total of 102 h.

Concerning the applicability, the accuracy of the data derived based on the simplified approaches was determined. The results are summarized in Table 12.

**Table 12: Results of benefit and applicability evaluation**

Approach	Savings [h]	Absolute deviation [kg CO <sub>2</sub> e]	Relative deviation [%]
Reference APCB	155	~ 4 kg CO <sub>2</sub> e	~ 3.6
Selected components	210	~ 6 kg CO <sub>2</sub> e	~ 5.3

### 3.3. Results and conclusions

Reflecting on the results of simplifying the LCA methodology for electronics, especially for providing quantitative environmental data in terms of product declarations or footprints, it can be summarized that both of the described approaches basically can be applied. Both need to be investigated further and additional steps are necessary to handle the described limitations for full implementation. Especially when working with reference assemblies, such as in this case APCB, the trend of ADP and its inconsistency with the other impact categories have to be managed. The difference in the trend of ADP, compared to the other impact categories can be attributed to the power electronics and the different assemblies within the power range that was studied. The power electronics,

significantly contributing to ADP, can be mounted directly on the PCBs with smaller nominal output powers, whereas for the higher nominal output power they have to be provided in the form of additional modules.

Based on our first investigations, it can be concluded that the approach using selected components and a standard compensation (for the components that have been eliminated) has more benefits and can be more easily transferred to other product groups. The lower accuracy has to be taken into account, however it is still sufficient so that it can still be managed. The decision regarding which approach to choose essentially depends on the devices being studied. Their composition and the associated technology have the most influence on the corresponding trends of the chosen impact categories.

Finally, it can be concluded that the objective of defining a simplified approach, which can be easily applied to (more or less) all products primarily based on electronics, has not been met. Currently, for both approaches a detailed, product-specific view based on detailed life cycle assessments is still necessary. This is either to derive the approximation function (including the limitations) or to determine the standardized compensation value.

## 4. SUMMARY AND OUTLOOK

The extensive LCA studies on frequency converters showed the high importance of ecodesign measurements addressing the efficient, application-specific system design. Oversizing devices will lead to a significant reduction of environmental impact in most cases.

Concerning the simplification of LCA, two possibilities were evaluated and will lead to a reduction of calculation time by keeping deviations to a detailed assessment at manageable levels. Both approaches still require further investigation on how to handle their limitations, which depend to a high degree on the assembly and configuration of the devices under study. For instance, non-linear functions and/or compensation of components that have been cut-off by taking into consideration the quantity and a standardized mean value.

## 5. REFERENCES

[1] Kirana Chomkhamisri, Nathan Pelletier, "Analysis of Existing Environmental Footprint Methodologies for Products and Organizations: Recommendations, Rationale, and Alignment", European Commission Joint Research Center, Institute for Environment and Sustainability, 2011

[2] European Commission, "A resource-efficient Europe – Flagship initiative under the Europe 2020 Strategy", Communication from the Commission to the European

Parliament, the Council, the European Economic and Social Committee and the Committee of Regions, 2011

[3] FprEN50598-3:2014, “Ecodesign for power drive systems, motor starters, power electronics & their driven applications – Part 3: Quantitative ecodesign approach through life cycle assessment including product category rules and the content of environmental declarations”, to be published.

[4] Weidauer, J., *Elektrische Antriebstechnik*, Siemens AG, Erlangen, 2008

[5] ISO 14040:2006, « Environmental management – Life cycle assessment – Principles and framework”, 2006

[6] “Product Specific Requirements: Variable speed electric drives”, PSR 2000:7 Version 1.0, The International EPD System, 2000

[7] FprEN50598-1:2014, “Ecodesign for power drive systems, motor starters, power electronics & their driven applications – Part 1: General requirements for setting energy efficiency standards for power driven equipment using the extended product approach (EPA) and semi analytic model (SAM)”, to be published

[8] A. Thomas, “Fixed Speed Drives – Energy Efficiency”, special print from etz special edition S4/2011, Siemens AG, Order No. E20001-A250-P301-X-7600, Fürth, Germany, 2012

**C-II: NEW STANDARD ON ECODESIGN FOR POWER  
DRIVE SYSTEMS, MOTOR STARTERS, POWER  
ELECTRONICS & THEIR DRIVEN APPLICATIONS –  
INTRODUCING THE EXTENDED PRODUCT APPROACH  
AND PRODUCT CATEGORY RULES FOR MOTOR  
SYSTEMS**

LECTURE 2.14.1., CARE INNOVATION 2014 CONFERENCE, VIENNA.

# NEW STANDARD ON ECODSIGN FOR POWER DRIVE SYSTEMS, MOTOR STARTERS, POWER ELECTRONICS & THEIR DRIVEN APPLICATIONS: INTRODUCING THE EXTENDED PRODUCT APPROACH AND PRODUCT CATEGORY RULES FOR MOTOR SYSTEMS

*Johannes Auer<sup>a</sup>, Benno Weis<sup>b</sup>*

*<sup>a</sup>Department for Environment, Health & Safety, Industry Sector, Siemens AG, Germany*

*<sup>b</sup>Department for Research & Development, Motion Control Systems, Drive Technologies, Industry Sector, Siemens AG, Germany*

↓  
↓  
↓

**Abstract:** In the context of the Energy-Related Product Directive [ErP], which addresses various products in terms of their energy efficiency, a new European standard series (EN 50598) was developed to support the ecodesign of complete drive systems with regard to their application, e.g. pumps. It provides a general methodology for the energy efficiency standardization of any extended product including an included motor system by using the methodological guidance of the extended product approach [EPA] and introduces energy efficiency indicators [EEI] for the respective drive system, including the measurement and calculation methods. It enables product committees for driven equipment with included motor systems to work with the relative power losses of the included motor system (e.g. PDS) in order to determine the system energy efficiency aspects for the extended product by calculation. It is based on specified calculation models for speed/load profiles, load-time profiles and relative power losses of appropriate torque versus speed operating points. The standard also covers requirements for environmental declarations and product category rules for life cycle assessments of motor systems.

↓  
↓  
↓  
↓

## 1. INTRODUCTION

The Energy-Related Products [ErP] Directive of the European Union addresses products with a significant contribution (active or passive) to energy consumption. These products are assessed with a defined methodology in certain lots to evaluate potential improvements in terms of efficiency and to define the necessary measures. These are then regulated via so-called implementing measures in the form of EU regulations. One aspect of these implementing measures are the energy efficiency classes for electric motors introduced to the market from January 2015 [1]. Associated with the implementing measures are harmonized European standards describing necessary procedures to ensure compliance with the regulation, for instance in terms of measurement for energy efficiency determination [2]. One point often not considered and/or addressed in terms of energy efficiency is the aspect of application within a system. In accordance with the

directive and the regulation, electric motors placed on the EU market have to comply with energy efficiency class IE3 or IE2 when operated with a variable speed drive (VSD). Operating a fixed-speed application with a VSD just generates additional losses compared to directly networked operation with starters and contactors, whereas for variable speed applications, for instance in certain pumps and ventilation systems, the VSD can really improve efficiency [3]. To improve this situation, the European standardization organization CENELEC was commissioned by the European Commission to set out harmonized standards for the eco design and efficiency determination of drive systems (M/470, M476, M495) [2]. Within CENELEC, the technical committee TC22X for power drive systems, working in close collaboration with other technical committees involved with the directive, regulations and the associated, harmonized standards (such as TC17B, TC2 and CEN TC197) has elaborated a new family of standards, the EN50598 "Ecodesign for

power drive systems, motor starters, power electronics & their driven equipment”, which will be available at the beginning of 2015.. This will apply to drive systems in the power range from 0.12 kW up to 1000 kW.

The standard consists of 3 parts:

- The EN5098-1 describes the extended product approach (EPA) to derive energy efficiency indicators (EEI) using semi analytical models (SAM) and the requirements which must be met to apply this approach to drive applications,
- The EN5098-2 standardizes the efficiency determination of frequency converters and their driven applications,
- The EN5098-3 describes the application of a qualitative and quantitative eco-design process, including product category rules for life cycle assessments and the content of environmental declarations.

The main aspects of all parts will be described, including the implications for manufacturers, in this paper.

## 2. EXTENDED PRODUCT APPROACH

### 2.1. General

As stated above, the EN5098-1 specifies a methodology to determine the energy efficiency index (EEI) of an application, based on the concept of semi analytical models (SAM). The methodology is called the extended product approach (EPA).

It enables product committees for driven equipment (the extended product – EP) with included motor systems to work with the relative power losses of the included motor system in order to determine the system energy efficiency aspects for the extended product by calculation. The extended product and its components are illustrated in Figure 1.

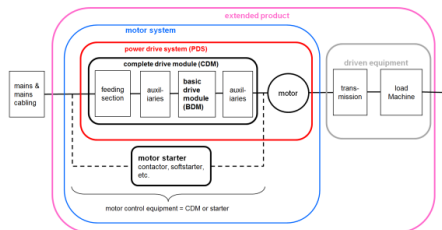

**Figure 1: The extended product (EP) is defined as the motor system and the driven application. The motor system is defined as a power drive system (PDS – complete drive module and motor) or motor starter and motor.**

The system energy efficiency calculation has to be based on specific calculation models for speed/load profiles, load-time profiles and the relative power losses of appropriate torque versus speed operating points. The standard specifies the tasks and responsibilities of the different stakeholders in creating or using these extended product standards.

### 2.2. Workflow and requirements for the semi-analytical model (SAM)

The determination model for the losses or the energy efficiency index of an extended product is called the "semi analytical model (SAM)", which includes physical and mathematical parameters and calculation algorithms of the subparts of an EP.

Figure 3 illustrates the application of the EPA including the tasks to be performed by affected stakeholders. It also visualizes the complexity and need for collaboration of the involved stakeholders and the need for a harmonized approach (e.g. consistency between the standards produced by different technical committees) through standardization.

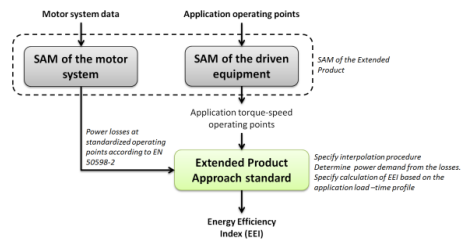
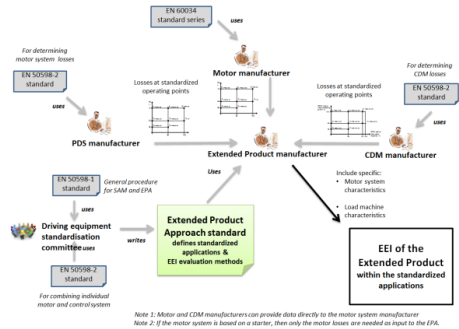

**Figure 2: Illustration of the workflow for application of the EPA based on SAM**

Figure 2 also shows how the SAM of the motor system (left-hand side) is linked to the SAM of the driven equipment (right hand side). The links in-between both semi analytical models are the load loss points of the motor system (e.g. PDS) and their permissible tolerances. The actually required operating points have to be defined by the semi analytical model of the driven equipment.

The motor system data (including the specific SAM) containing the losses (e.g. PDS, PDS losses) is defined in EN5098-2, whereas the semi analytical energy consumption models of the PDS-driven application (right-hand side of Figure 2) have to be drafted by their responsible product committees using the same approach.

Figure 3 shows how the different data sources have to be combined.



**Figure 3: Illustration of the different stakeholders affected by standardized determination of the energy efficiency index for extended products, such as driven applications, by combining data from different sources.**

It is the responsibility of the technical committees for specific applications to standardize publicly available SAMs for their applications.

The SAMs for the subparts of the extended product are necessary in order to determine the overall power losses of the extended product. The outcome of the SAM, considering the most relevant energy efficiency aspects of all components of the system, can be used to calculate the energy efficiency index (EEI). This index then allows a quantitative distinction to be made between efficient and inefficient solutions for an application for which the extended product can be used. This EEI value therefore has to be provided by the manufacturer in a metric scheme, for instance in the user's documentation or the catalogue.

**2.3. SAM main characteristics**

The energy savings that can be achieved, or in other words the design of the most efficient system for a certain application, often depends on the operating point (OP) at which the extended product is operated. Two application-related characteristics, the torque or power versus speed profile and load-time profile, are particularly useful for describing the extended product and the way it is operated. These two characteristics can be used as input data to derive the right motor control equipment of the extended product in terms of energy efficiency performance.

**2.3.1 The torque or power versus speed profile**

This profile describes how the torque required by the driven equipment depends on its speed. It essentially depends on the type of driven equipment.

The torque or power versus speed profile describes how the torque  $T$  or power  $P$  required by the driven load varies with its speed  $n$ . The power is also the product of torque and speed. Most existing driven equipment can be categorized into one of the basic torque and power vs speed profiles shown in Figure 4.

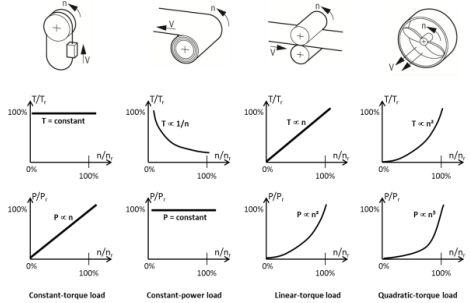

**Figure 4: Typical torque/power vs. speed profiles for different extended products**

**2.3.2. The load-time profile**

This profile describes the various power levels required by the driven equipment, including standby, and the fraction of time during which the equipment is operated at these levels. The load-time profile essentially influences the sizing of the motor system and how the extended product is operated in practice. The desired behavior of the extended product, as well as the characteristics of the motor, is defined by one or more operating points at which the motor will have to be operated.

Depending on the process demands, the motor may not be running at rated output power all the time. Part load is a situation where the application requires reduced torque and/or speed compared to the rated values.

The efficiency of an extended product heavily depends on the load level. Furthermore, stand-by (SB) losses of soft starters and CDMs have to be considered. They are present in periods where the power section is disabled but the control is still supplied. Standby losses are losses generated, for example, by the power supply of the control section.

To estimate the efficiency of an extended product and compare several potential control solutions, it is therefore essential to know which levels of mechanical and electrical power are needed by the extended product and in which time fraction.

To calculate the electrical energy needed, the individual required electrical power supplies have to be multiplied by their time span. Time fractions in percentage terms have to be based on the whole operating time over one productive year of the installation.

An example of operating points over time is shown in Figure 5.

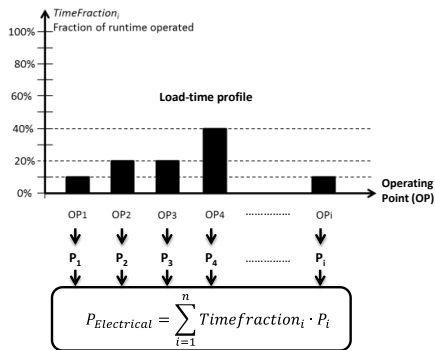

**Figure 5 — Typical power required by application over time fraction = load-time profile required to calculate the electrical energy needed**

The duty profile describes the requirements of the extended product in terms of mechanical power. For each operating Point  $OP_i$ , the electrical power  $P_i$  that must be supplied by the mains depends on the mechanical power and the overall extended product losses (or equivalently its efficiency) at this level. The weighted average electrical power  $P_{Electrical}$  required to run the extended product as desired is:

$$P_{Electrical} = \sum_{i=1}^n (Timefraction_i \cdot P_i)$$

The weighted average electrical power is directly relative to the electrical energy consumption (in e.g. kWh) required by the extended product during a certain runtime period:

$$E_{Electrical} = P_{Electrical} \cdot Runtime$$

The weighted average electrical power (or equivalently electrical energy) can be calculated for several potential control strategies suitable for the extended product (e.g. switchgear and CDM) and this information used to choose the most efficient one.

#### 2.4. Application of the extended product approach (EPA)

As stated above, application of the EPA including the (individual) SAMs to determine the EEI of an

extended product relies heavily on the collaboration of the involved stakeholders. The EPA itself is basically the combination of the SAMs of the involved (required) system components as regards the application.

The basic steps that consequently have to be taken by the extended product (driven system, application) technical committees are the following:

- specification and standardization of one (or more) torque versus speed and load-time profiles, considering typical loads and service conditions
- definition of an SAM for the extended product based on the eight operating points (torque versus speed) specified in EN50598-2,
- if necessary, definition of an appropriate method to determine losses at intermediate operating points,
- Specification of a method to derive an EEI (including tolerances) for the extended product.

These steps are summarized in Table 1 including the relevant inputs and outputs

**Table 1: Basic steps from a SAM to an EEI via EPA**

	Input	Output
SAM Motor System (MS)	Motor system characteristics (physical components, rated power...)	Losses of MS at standardized operating points
SAM Extended Product (EP)	Output of SAM MS + characteristics of EP	Losses of EP at standardized operating points
Extended Product Approach	Output of SAM EP + requirements relating to the application (load-time profiles, operating time...)	Energy efficiency index of EP for the application

The EPA is consequently a merger of two (or more) SAMs based upon a set of relative losses at a determined torque/power versus speed operating points and a load profile of the driven equipment [4].



### 3. ENERGY EFFICIENCY INDICATORS FOR POWER DRIVE SYSTEMS AND MOTOR STARTERS

This part of the standards family, the EN 50598-2, basically applies the EPA to drive systems and standardizes the EEI (IE- and IES classes). It also standardizes the calculation and test procedure for losses, including losses of reference components (such as reference PDS, CDM and loads/motor) and the mathematical model for their calculation.

#### 3.1. Classification of frequency converters and power drive systems

The losses of a PDS (complete drive module and motor) depend largely on operating points (as well as ultimately the load profile – see clause 2). To minimize the effort required, eight operating points were defined at which losses have to be determined by the respective manufacturer. These are displayed in Figure 6.

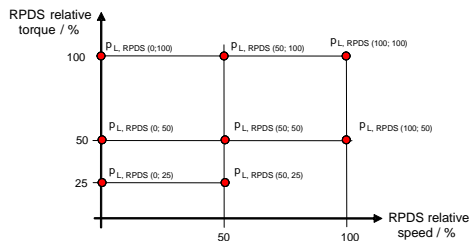

**Figure 6: Operating points for loss determination of power drive systems**

Since a frequency converter has no speed or torque, the relative output frequency (modulation) and the relative current corresponding to the operating point are used for loss determination in this case. These are displayed in Figure 7.

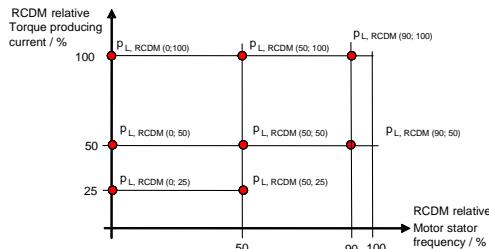

**Figure 7: Operating points for loss determination of frequency converters (complete drive module)**

As well as the nominal operating points, seven further part load points are defined in the standard, allowing a determination of losses by linear interpolation or extrapolation within the first quarter of the diagram.

To determine losses at the rated operating point, a control factor of 90 % is set to avoid over-modulation. Otherwise, the control factors of the frequency converters correspond to the operating points of the drive system. Some of these operating points are at very low speeds with output power at almost zero, as well as efficiency, independently of high or low losses. Losses are consequently the leading indicator of drive system performance in these cases.

The losses of frequency converter and power drive systems determined in this way enable users, e.g. in pump applications, to determine the most efficient solution for their system via the EPA explained in clause 2 using a SAM.

Additionally, these losses form the basis for the comparable classification of frequency converters as well as drive systems according to IE classes (International Efficiency). For motors (low voltage standard motors), these have already been defined in IEC60034-30 [7]. For frequency converters, classification is carried out through comparison to a reference device, which is defined in the standard as a “state of the art” 3-phase voltage source inverter with 2-level technology and a nominal voltage of 400V. To evaluate the IE class of the frequency converter, losses are determined at 90 % control factor (corresponding to 100% torque building current) and compared to the losses of the reference device. If losses are approximately the same (+/- 25%), the converter is rated IE1. If losses are lower, it is rated IE2 and in the case that losses are higher, it has to be rated as IE0, in either case more than the standardized tolerance of 25 %.

For drive systems, determination of the IES-class (International Efficiency for Systems) works basically the same way. IES1 covers the range of ± 20% of losses in a reference drive system. This is illustrated in Figure 8.

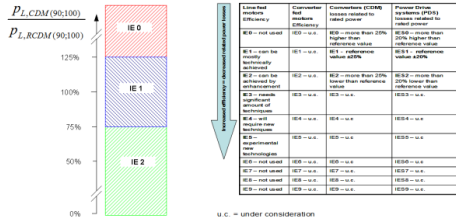

**Figure 8: Illustration of IE class evaluation of frequency converters and drive systems**

### 3.2. Loss determination of frequency converters

To reproducibly determine the losses of frequency converters, the converters have to be subjected to electrical load in a defined way. The parameters output current ( $I_{out}$ ) and phasing ( $\cos\Phi$ ) to the base frequency of the output voltage significantly influence losses. These have consequently been standardized for loss determination with the different currents ( $I_q$ ).

Rectifier losses are mostly influenced by the apparent power load of the converter. Effective converter power is therefore determined by the above parameters and the modulation (m) corresponding to the output frequency.

The standard leaves manufacturers three different approaches to loss determination as a basis for IE classification:

- Mathematical calculation
  - To minimize the measurement effort required, a mathematical calculation is allowed for loss determination. Another methodology which has been used to determine reference converter losses is introduced in the standard. Manufacturers are free to choose an appropriate calculation approach but are responsible for the results. Consequently, these must be capable of being substantiated by measurements.
- Input – output measurement
  - As an alternative to mathematical calculation, losses can be determined by electrical measurement. Input power (mains side) and output power (motor side) are measured (at the eight operating points) by power measurement devices and compared in order to derive the corresponding losses. Attention has to be paid to the capability, e.g. the accuracy, of the measurement device (losses are relatively small compared to overall power).
- Calorimetric measurement
  - The benefit of calorimetric measurement is greater accuracy in loss determination than other methods. However, it entails more

effort in terms of the measurement process itself. The standard describes two methods (1 or 2 measurement chambers) for calorimetric measurements. In both cases, the device and a calibration resistance (with known dissipation losses) are used in the chamber(s) and the temperature of inlet air and outlet air is measured to determine the losses of the frequency converter.

### 3.3. Loss determination of drive systems

Two methods are possible to determine the losses of a power drive system, converter and motor. These are described in detail in the standard, as calorimetric measurements are not practicable (necessary thermal insulation between the motor shaft and loading machine).

- Calculation
  - When the losses of the drive system components are known at the eight operating points, they can be added up to determine the total system losses.
- Input – output measurement
  - Comparable to the approach used for frequency converters, a comparison of electrical input power (mains side) and mechanical output power (motor shaft) form the basis for the evaluation of losses in the drive system.

[5]

## 4. THE DEFINITION OF AN ECODSIGN PROCESS, INCLUDING PRODUCT CATEGORY RULES FOR LIFE CYCLE ASSESSMENTS AND THE CONTENT OF ENVIRONMENTAL DECLARATIONS

### 4.1. General

This part of EN 50598 specifies the process and requirements for implementing environmentally conscious product design principles (ECD), for evaluating ecodesign performance and for communicating potential environmental impacts of power electronics (e.g. complete drive modules, CDM), power drive systems and motor starters, all used for motor-driven equipment in the power range of 0.12 kW up to 1000 kW and low voltage (up to 1000 V) applications over their whole life cycle.

It defines the content for two different environmental declarations based on EN ISO 14021:

- The basic version - which will be referred to in this context as environmental declaration type II, with basic data and qualitative statements on ecodesign.

- The full version - which will be referred to in this context as environmental declaration type II+, based on a life cycle assessment and including quantitatively evaluated potential environmental impacts. Here, the general principles of EN ISO 14025 are taken into account and product category rules [PCR] for motor system components are included to ensure a harmonized approach.

#### 4.2. Environmentally conscious design process

An environmentally conscious design process culminates in a declaration of the potential environmental impact or environmental claims of the components of a motor system in an environmental declaration or footprint.

ECD requires the identification, measurement and reporting of particular impacts. IEC 62430 describes the principles of ECD with the goal of reducing the potential environmental impacts of products and is referred to in the EN50598-3 standard. This is illustrated in Figure 9.

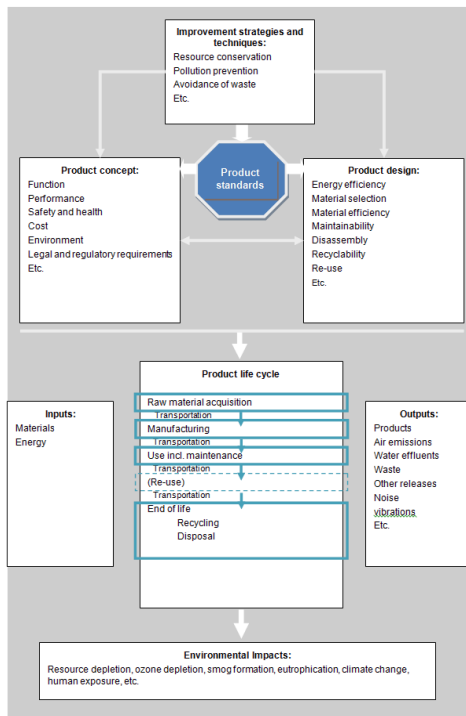

**Figure 9: Illustration of the basic principles of ECD – Consideration of environmental issues in the context of the product’s life cycle.**

As mentioned before, the standard leaves the manufacturer two choices (basic: qualitative; full: quantitative) on how to approach and implement ECD. The process itself has to be described in the manufacturer’s (design) process instructions and if possible should be integrated into the management system (e.g. ISO 14001 or 9001) of the company. If the ECD is an integral part of a certified management system, third party verification through the certification audits is assured. If the manufacturer has no certified management system, the assurance of verification must be provided by internal audits.

##### 4.2.1. Basic ECD

This is the basic qualitative approach. It requires manufacturers to identify the main environmental issues of their products and to define appropriate improvement strategies in the context of factors such as energy efficiency, material usage (e.g. legislative requirements) and recyclability. This can be done, for instance, by adding these topics and strategies to the product requirement and feature specifications and by involving relevant functions such as environmental specialists in the design process. Benefits for manufacturers include a systematic approach to all relevant environmental and compliance issues, e.g. substance legislation such as RoHS, or other directives such as WEEE. The outcome can also be used for qualitative environmental statements on the product level, in context of this standard as a basic environmental declaration referring to ISO 14021 type II environmental declarations.

##### 4.2.2. Full ECD

In addition to the principles of the basic approach, a life cycle assessment [LCA] provides the possibility to quantify the ECD. By quantification, manufacturers can be sure of really focusing on on the most relevant environmental issues and of quantifying improvements in terms of a reduction of, for instance, CO<sub>2</sub> emissions. Since an LCA requires a large amount of work, a smart approach is key to ensuring efficient implementation. For instance, manufacturers can define product families and assess these using selected key products. If these product families are homogeneous in terms of the manufacturing technologies and material composition used, potential environmental impacts can then even be approximated using linear regression. In case of a full ECD approach using an LCA, the data can also be used for full environmental declarations as defined by the standard, provided the standardized product category rules (PCR) are applied.

#### 4.3. Environmental product declarations

As mentioned above, an environmental declaration is a statement from a manufacturer regarding environmental claims or potential impacts on the (extended) product level. The ISO 14020 standard defines the general principles to be followed. The maximum duration of validity of environmental declarations issued in compliance with this standard is set at 5 years. After this period, a review must be performed by the issuer.

#### 4.3.1. Basic environmental declaration

This is a manufacturer self-declaration, based on a qualitative ECD approach and referred to as an ISO 14021 type II environmental declaration. The standard lists the content which must be communicated in this kind of environmental declaration:

- Information about the manufacturer and description of the product family, the reference product and its packaging
- Constituent materials and substances
- Utilization phase – efficiency classes, related electrical power losses and if applicable remarks on an optimized design of the motor system from EN 50598-2.
- End of life – The manufacturer has to provide information to facilitate end of life treatment for the products in the scope of the environmental declaration, e.g. dismantling, disposing, and recycling instructions compliant to IEC/TR 62635

#### 4.3.2. Full environmental declaration

If the manufacturer wishes to implement a full ECD using the LCA, he can also use the output for LCA-based environmental self-declarations if the provided PCRs are considered in the LCA. In this standard, a new declaration type is introduced and referred to as a type II+ declaration. It is ISO 14021-compliant but also takes the main aspects of ISO 14025 (LCA-based type III environmental declarations) into account. For full compliance with ISO 14025, in addition the manufacturer must join an (external, third party) environmental declaration program.

The idea behind the type II+ declaration is to enhance the comparability of this type of declaration through the common, standardized rules of the underlying LCA and standardized content, without the necessity for joining environmental declaration programs requiring additional resources and costs. Standardizing the content and calculation rules also assures the usage of these declarations within the context of the extended product approach, on the system level, through the simple addition of the content of the component declarations.

The standard lists the content which must be communicated in this type of environmental declaration:

- Information about the manufacturer and description of the product family, the reference product and its packaging,
- Constituent materials and substances
- Information on life cycle stages and their corresponding potential environmental impacts and additional parameters as listed in Figure 10 and Figure 11,
- Additionally concerning
  - Utilization phase – efficiency classes, related electrical power losses and if applicable remarks on an optimized design of the motor system from EN 50598-2,
  - End of life – The manufacturer has to provide information to facilitate end of life treatment for the products in the scope of the environmental declaration, e.g. dismantling, disposing, and recycling instructions compliant to IEC/TR 62635.

Impact Assessment Model, Source	Impact Category Name	Impact Category Abbreviation	Unit	Characterization factor name	Characterization factor abbreviation
Bern model over a 100 year time horizon (IPCC, 2007)	Climate Change	CC	kg CO <sub>2</sub>	Global warming potential	GWP
EDIP model over an infinite time horizon (IMAO, 1999)	Ozone Depletion	OD	kg CFC-11 <sup>a</sup>	Ozone Depletion Potential	ODP
LOTO-EURODS model, Van Zelm et al. 2008, implemented in ReCiPe)	Photochemical Ozone Creation	POC	kg NMVOC	Photochemical Ozone Creation Potential	POCP
Seppälä et al. 2006, Posch et al. 2008	Acidification	A	mole H <sup>+</sup> eq	Accumulated Exceedance	AE
Seppälä et al. 2006, Posch et al. 2008	Eutrophication terrestrial	ET	mole N eq	Accumulated Exceedance	AE
EUTRENED model, Struis et al. 2009 (implemented in ReCiPe)	Eutrophication aquatic	EF	kg P eq	Accumulated Exceedance	AE
USEtox model (Rosenbaum et al. 2008)	Human Toxicity, cancer effects	HT	CTUh	Comparative Toxic Unit for Human Health	CTUh
USEtox model (Rosenbaum et al. 2008)	Human Toxicity, non-cancer effects	HT	CTUh	Comparative Toxic Unit for Human Health	CTUh
USEtox model (Rosenbaum et al. 2008)	Ecotoxicity freshwater	ET	CTUe	Comparative Toxic Unit for ecosystems	CTUe
ToxP model (Rui and Spadaro, 2004, Grieco et al. 2007)	Particulate Matter	PM	kg PM <sub>2.5</sub>	Particulate matter with a diameter of 2.5 µm or less	PM <sub>2.5</sub>
CML2002 model, van Oenig et al. 2002	Resource Depletion, mineral	MD	kg Sb	Abiotic Depletion Potential for non-fossil resources	ADP-elements
CML2002 model, van Oenig et al. 2002	Resource Depletion, fossil	FD	MJ, net caloric value	Abiotic Depletion Potential for fossil resources	ADP-fossil fuels

**Figure 10: Table of standardized environmental impact categories and corresponding models and units to be displayed in a type II+ environmental declaration**

Topic	Unit	Comment
Use of non-renewable primary energy	MJ, net caloric value	Lower heating value
Use of renewable primary energy	MJ, net caloric value	Lower heating value
Net use of fresh water	m <sup>3</sup>	
Hazardous waste disposed	kg	
Non-hazardous waste disposed	kg	
Radioactive waste disposed	kg	

**Figure 11: Table of additional parameters to be displayed in a type II+ environmental declaration**

#### 4.4. Product category rules (PCRs)

For LCA-based environmental declarations, the standard defines PCRs (according to ISO 14025) for motor systems and their components. The standard is divided into basic PCRs (core PCRs), common and basic rules for all components of the drive system and further product-specific rules (PSR), e.g. for converters, starters etc. The PSRs are designed to allow further product-specific simplification of the LCA, e.g. through differentiation between main components, involving mandatory consideration, and auxiliary components, where consideration is voluntary due to low significance. These rules have to be applied in the LCA if the results are meant for external communication. They define certain parameters for all manufacturers to enhance the comparability and usability (in a system context) of declarations. Main aspects:

- Functional unit – defined as one product providing a certain output of electrical or mechanical power,
- Cut-off criteria – the overall contribution to environmental impacts of the impacts of parts excluded from the LCA study, i.e. those parts (not main parts) not looked at in LCA study, must not exceed 1 percent in the specified impact categories in each respective life cycle stage and may not contain any substances subject to legal regulations which exceed any mass limit of such a regulation,
- System boundaries – the life cycle and system boundaries of a device cover the manufacturing, utilization and end-of-life (EoL) phases. The so-called superstructure, such as the building of a plant, infrastructure, manufacture of production goods, transport packaging (packaging other than the final product's packaging) and personnel activities, which do not relate directly to the production of the device, shall not be looked at in this context. The system boundaries in terms of the natural environment are defined as flows of materials and energy resources to the system and flows from the system caused by emissions / waste in the air, water and ground.

In terms of data quality, the standard refers to compliance with the OLCF handbook of the JRC.

#### **4.5. Scaling functions for homogeneous product families**

The basic idea of scaling functions is to reduce the work involved in deriving the potential environmental impacts without significant losses in

quality e.g. for reporting purposes in the extended product view. EN 50598-2 deals in detail with the efficiency and losses of a motor system in the utilization phase. The two open life cycle stages in terms of ecodesign and reporting an environmental footprint are consequently manufacturing and end of life. Since both basically depend on the raw material input and the physical product design, they can be accounted for in one function. Under certain circumstances, where products can be clustered into a homogeneous product family, a scaling function can be derived using so-called key products to calculate potential environmental impacts for all variants within this family without conducting an LCA for each variant and without major losses of quality in terms of the quantitative statements included in the environmental declaration. The homogenous product family is part of a (larger?) product family and must be defined by the manufacturer by scaling potential environmental impacts on the basis of a certain environmental parameter (e.g. performance-specific variables  $\rightarrow$  g CO<sub>2e</sub> / kW or product weight  $\rightarrow$  g CO<sub>2e</sub> / kg). This means that the homogenous product family must be technologically and functionally consistent, e.g. AC motors, performance class IE2, X - Y kW.

The used scaling function must be based on a linear approximation ( $f(x) = m \cdot x + t$ ) and have the minimum accuracy of  $R^2 = 0.97$ .

#### **4.6. Environmental declaration of a driven application (extended product)**

An additional point of this standard is the use of data from the environmental declaration of the motor system components to derive the environmental footprint of the application, e.g. pump or ventilation system, by the system manufacturer. This is made possible by the harmonized approach to environmental declarations and in particular the life cycle assessment through the standardized product category rules.

The basic idea is that the environmental declaration of the driven application is a summary of environmental declarations of the motor system components needed to drive the application. This environmental declaration is generated through the addition of each component's potential environmental impacts and the input materials (if the environmental declaration is a type II+ declaration) or just the input material and a summary of qualitative statements (if the environmental declaration is a type II declaration). The procedure is illustrated in Figure 12 [6].

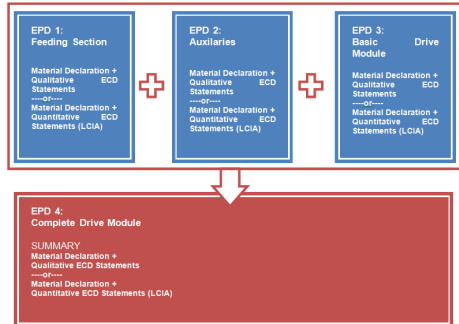

**Figure 12: Illustration on how to derive an environmental declaration for an extended product by the summation of data from different environmental declarations**

## 5. SUMMARY AND OUTLOOK

With the new standard series EN50598 for drive systems, the first comprehensive ecodesign standard for drive systems has been developed in the context of standardization mandates issued by the European Commission relating to the ErP directive. It defines a sophisticated approach to energy efficiency determination for converters and for drive systems in the application context through semi analytical models and the extended product approach. Manufacturers of power drive systems now have to evaluate losses at eight defined operating points and use the corresponding energy efficiency index. This information then has to be provided with the product documentation. It also defines requirements for qualitative and quantitative environmentally-conscious design processes and environmental declarations. Manufacturers can choose their approach and are responsible for its implementation. The standard also introduces a new LCA-based environmental self-declaration type (type II+) and defines product category rules for this. The standard will be publicly available at the beginning of 2015.

## 6. REFERENCES

- [1] European Commission, Energy Efficiency, [http://ec.europa.eu/energy/efficiency/ecodesign/eco\\_design\\_en.htm](http://ec.europa.eu/energy/efficiency/ecodesign/eco_design_en.htm)
- [2] CENELEC, European Mandates, <http://www.cenelec.eu/aboutcenelec/whatwestandfor/supportlegislation/europeanmandates.html>
- [3] A. Thomas, "Fixed Speed Drives – Energy Efficiency", special print from etz special edition S4/2011, Siemens AG, Order No. E20001-A250-P301-X-7600, Fürth, Germany, 2012

[4] FprEN50598-1:2014, Ecodesign for power drive systems, motor starters, power electronics & their driven applications – Part 1: General requirements for setting energy efficiency standards for power driven equipment using the extended product approach (EPA) and semi analytic model (SAM), to be published

[5] FprEN50598-2:2014, Ecodesign for power drive systems, motor starters, power electronics & their driven applications – Part 2: Energy efficiency indicators for power drive systems and motor starters, to be published

[6] FprEN50598-3:2014, Ecodesign for power drive systems, motor starters, power electronics & their driven applications – Part 3: Quantitative ecodesign approach through life cycle assessment including product category rules and the content of environmental declarations, to be published.

[7] IEC 60034-2-1 ed. 2: Rotating Electrical Machines - Part 2-1: Standard methods for determining losses and efficiency from tests (excluding machines for traction vehicles)



The PhD research project has its background mainly in the fields of product development & design, manufacturing systems and quantitative sustainability assessment. Related organizational and management research is also drawn upon, as well as systems engineering approaches. Research focus lies in areas where these fields overlap and complement each other in the development process in applications. context. As a result, an holistic EcoDesign approach is outlined, based on an eco-efficiency tool and supportive means, such as necessary simplifications for the underlying assessment methods, which can be utilized e.g. for portfolio management purposes.

**Johannes Auer**

**Division for Quantitative Sustainability Assessment  
Department of Management Engineering  
Technical University of Denmark**

**Siemens AG  
Process Industries and Drives Division  
Environmental Protection, Health Management and  
Safety**

Siemens AG | PD EHS  
Gleiwitzerstr. 555  
90475 Nürnberg

<https://www.siemens.com/>