

Riometry at the Italian Antarctic station of Terra Nova Bay^(*)

G. DE FRANCESCHI⁽¹⁾, A. DE SANTIS⁽¹⁾, M. CERRONE⁽¹⁾, M. CHIAPPINI⁽¹⁾
P. PALANGIO⁽¹⁾, G. ROMEO⁽¹⁾ and G. RICCI⁽²⁾

⁽¹⁾ *Istituto Nazionale di Geofisica - Vigna Murata 605, 00143 Roma, Italy*

⁽²⁾ *ENEA - V.le Regina Margherita 125, 00198 Roma, Italy*

(ricevuto il 5 Dicembre 1996; approvato il 27 Febbraio 1997)

Summary. — A solid-state riometer has been installed at Terra Nova Bay (74°42'S and 164°06'E) during the IX Italian Antarctic expedition (1993/1994) to provide, in the frame of the geophysical observatories, studies on the ionospheric absorption in the lower part of the ionosphere. This kind of measurements will integrate the already existing active vertical ionospheric sounding and the magnetic absolute vector observations, with the objective of investigating the state of the ionosphere-magnetosphere coupling. In order to evaluate the base disturbance to the riometer, a remote campaign has been performed at McCarthy Ridge, rather far from the base station, where no anthropic noise is expected. Preliminary data analysis confirms the good quality of the Antarctic riometer observations.

PACS 94.20 – Physics of the ionosphere.

PACS 96.40 – Cosmic rays.

PACS 01.30.Cc – Conference proceedings.

1. – Generality

To study the temporal variations of the ionosphere-magnetosphere coupling system in both quiet and disturbed heliogeophysical conditions, a systematic and simultaneous observation of several physical quantities is needed, *e.g.*, the critical frequencies of E, F1, F2 ionospheric layers, and the Earth's magnetic-field components. An array of observation points, suitably distributed in the area of interest, is also necessary to have information about the spatial morphology of the above-mentioned quantities.

2. – The TNB riometer

In the Italian Antarctic Base of Terra Nova Bay (TNB; 74°42'S, 164°06'E) a Geomagnetic and a Ionospheric Observatory have been working since 1987 and 1992, re-

(*) Paper presented at the VII Cosmic Physics National Conference, Rimini, October 26-28, 1994.

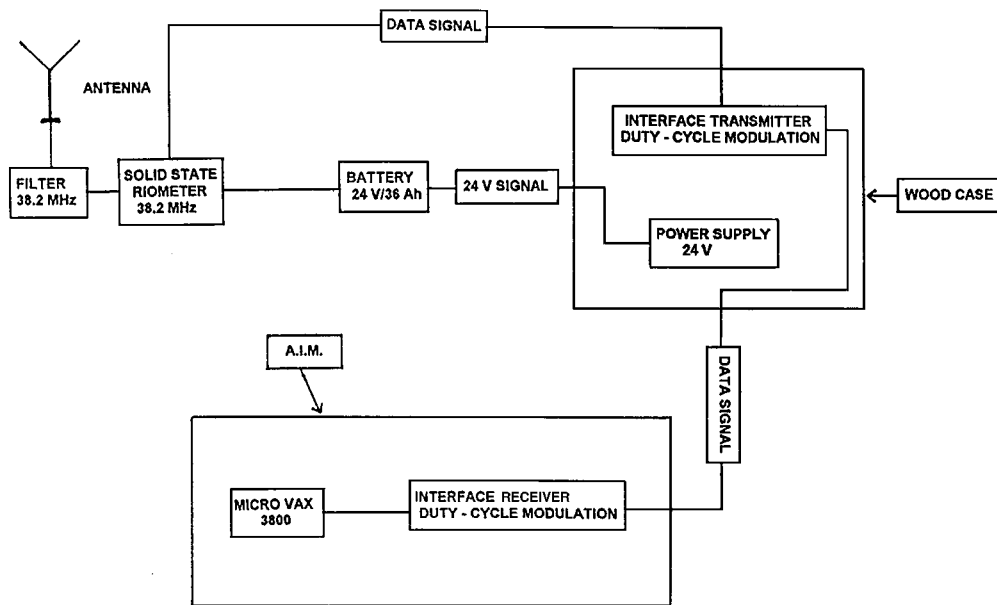

Fig. 1. – Block diagram of the riometer station at Terra Nova Bay (Antarctica).

spectively. In addition, during the 1993/94 Antarctic Campaign, in the frame of the new project “Ionosphere-Magnetosphere Coupling”, a riometer (Relative Ionospheric Opacity Meter), operating at 38.2 MHz, was installed. This allows the specific study of the lower ionosphere, in particular the region at 40–60 km altitude, measuring the cosmic noise systematically.

Since the cosmic flux coming from the outer space can be considered constant, any deviation of that measured at the Earth’s surface can be attributed to the absorption of the lower ionosphere. This quantity is a function of: the electronic density, the collision frequency between electrons, neutral atoms, and molecules, angular wave frequency, angular gyrofrequency. In practice, the ionospheric absorption, expressed in decibel, is given by the logarithm of the ratio between the cosmic noise at quiet conditions and that measured at time t . The choice of the quiet curve is not simple. Generally it is deduced month by month, although a longer period of observations improves the quality of the determination of the quiet curve (*e.g.*, Krishnaswamy *et al.* [1] and references therein). A preliminary analysis to deduce the ionospheric absorption was based on the algorithms by Banzon *et al.* [2] and Chiappini *et al.* [3,4].

The riometric station installed at TNB is composed of a double-dipole receiving antenna, a solid-state receiver with a 38.2 MHz filter, 150 KHz band width by La Jolla Sciences (Ca-USA). The power energy is supplied by the main power of the Antarctic Base together with a couple of 12 V batteries, in case of main power electric interruptions. A block diagram is shown in fig. 1.

The cosmic-noise data, taken at 1 min sampling, were recorded during December 1993 and January 1994, by means of a PC286 IBM compatible and an A/D 15 bit converter, model 40 by Lawson Labs (Mt-USA). An example of riometer data is shown in fig. 2 concerning the first half month of December 1993.

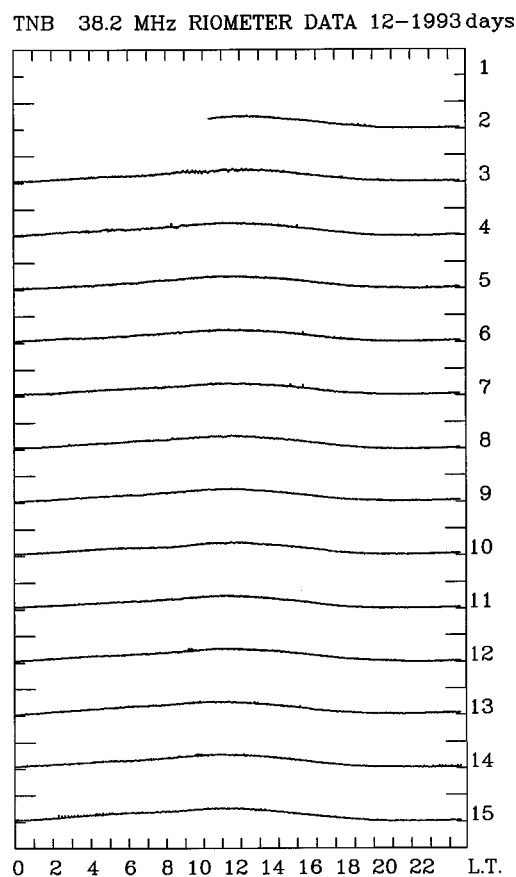

Fig. 2. – Daily behaviour of cosmic noise (arbitrary units) at 38.2 MHz as measured at Terra Nova Bay (Antarctica) for the first half month of December 1993.

The system was later modified to allow the data transmission and acquisition also during winter antarctic time, by means of a duty-cycle modulation from the riometer to the base computer center (a μ Vax 3800). According to the remote satellite interrogation, the data acquisition process was properly working at least up to the end of June 1994.

3. – Remote campaign

A second twin riometer was used to perform a temporary remote campaign at about 50 km from the TNB base, *i.e.* at McCarthy Ridge (800 m a.s.l. 74°38.4'S, 163°04.1'E). Since the absence of anthropic noise at this site, these measurements can be used to check the quality of data taken at TNB for comparison. Data sampling was 4 seconds, the acquisition period was 16-22 January 1994.

4. – Further work

Further work will consider two main points: 1) the improvement of the hardware-software of the riometer station as a permanent point of Antarctic observation; 2) the addition of a second riometer working at different frequency (*e.g.*, 30 MHz) and located at the same site; 3) the application of a more advanced time-space analysis (*e.g.*, De Santis and Chiappini [5]), also in connection with riometric, ionospheric and geomagnetic data coming from other Antarctic stations. Especially the latter item will have particular emphasis in order to investigate the characteristics of the magnetosphere as a whole.

* * *

This research was supported by the Italian Antarctic Research Programme (PNRA) whose facilities and resources are greatly acknowledged.

REFERENCES

- [1] KRISHNASWAMY S., DETRICK D. L. and ROSENBERG T. J., *The Inflection Point Method of Determining Riometer Quiet Day Curves*, *Radio Sci.*, **20** (1985) 123–136.
- [2] BANZON V., DE FRANCESCHI G. and GREGORI G. P., *The Mathematical Handling and Analysis of non-Homogeneous and Multivariate Historical Data Series*, *European Climate Reconstructed from Documentary Data: Methods and Results. ESF Project “European Paleoclimate and Man”*, edited by B. FRENZEL, Vol. 2 (Gustav Fisher Verlag, Stuttgart, Jena, New York) 1992, pp. 137–150.
- [3] CHIAPPINI M., BANZON V., DE FRANCESCHI G., DE SANTIS A., DIODATO L. and GREGORI G. P., *The Analysis of Geomagnetic and Ionospheric Data. Fractal vs. superimposed epoch approach: logical implications and practical effectiveness*, in *SIF Conf. Proc. “Italian Research on Antarctic Atmosphere”*, edited by M. COLACINO, G. GIOVANELLI and L. STEFANUTTI, Vol. 35 (Editrice Compositori, Bologna) 1992, pp. 505–520.
- [4] CHIAPPINI M., DE FRANCESCHI G., DE SANTIS A. and GREGORI G. P., *Geomagnetic and Ionospheric Time Series Analysis*, in *Conference Proceedings “Solar-Terrestrial Predictions-IV”*, edited by J. HRUSKA *et al.*, Vol. 3 (NOAA Environmental Research Laboratories, Boulder, Colorado, USA) 1993, pp. 81–97.
- [5] DE SANTIS A. and CHIAPPINI M., *Chaos and Fractal Behaviour of the Geomagnetic Field over Polar Caps: Some Preliminary Results*, in *SIF Conf. Proc. “Italian Research on Antarctic Atmosphere”*, edited by M. COLACINO, G. GIOVANELLI and L. STEFANUTTI, Vol. 45 (Editrice Compositori, Bologna) 1994, pp. 363–369.