

Research Journal of Applied Sciences 12 (2): 266-272, 2017

ISSN: 1815-932X

© Medwell Journals, 2017

A Model for Automatic Control of Home Appliances using DTMF Technique

¹O. Okokpujie Kennedy, ¹O. Odusami Modupe, ²P. Okokpujie Imhade and ¹Olusola Abayomi-Alli

¹Department of Electrical and Information Engineering, Covenant University, Ota, Ogun State, Nigeria

²Department of Mechanical Engineering, Covenant University, P.M.B. 1023, Ota, Ogun State, Nigeria

Abstract: Electrical devices and appliances cause a lot of problem and havoc if they are not switched off when they are not in use. This study developed a Dual Tone Multiple Frequency (DTMF) technology for the remote control of home appliances. A Dual Tone Multiple Frequency (DTMF) decoder MT8870, a mobile phone, a binary coded decimal decoder, a crystal pulse generator and other components were used for the model and development of the system. The dual tone multiple frequency decoder (MT8870) receives and converts decimal signals to binary. The binary signals are further processed and converted back to binary by the binary coded decimal decoder. The processed signals are then sent to the relay for appropriate switching. Dedicated phone digits send commands to devices/appliances by switching them on or off. The simulation was done using MATLAB 7.0 using accuracy and convergence time as performance metrics. The simulation results showed that the DTMF based home automation has high percentage of accuracy transmitting. The convergence time result showed that signal transmitted took shorter time to converge. In conclusion, the developed model proves to be efficient in controlling home devices/appliances remotely.

Key words: Automatic control, control of home appliances, Dual Tone Multiple Frequency (DTMF), home automation, remote control

INTRODUCTION

The world is going digital and remotely controlled systems are taking over. Devices/appliances like television sets, air conditioning systems, stereo sets, music players and etcetera come with remote controls for ease of use. Some of these devices that require remote controls send signals using infrared radiation (a kind of invisible red light that hot objects give off and halogen hobs use to cook with) (Obiazi *et al.*, 2009). Infrared radiations cover just above 10 m (Panth and Jivani, 2013; Samuel *et al.*, 2016). These devices which include home and office appliances such as air conditioners, fans, television sets and other electronic gadgets can be controlled remotely from any locations regardless of the distance. Improvements such as infrared, bluetooth, etc., show that life can be made simple. Remotely controlling devices at home, offices and industries is of growing interest which has been seen viable over time.

These days when calls are initiated and instructions, ideas, opinions information and etcetera are passed from one individual to another to perform specific functions in a particular place at a given point in time. Dual Tone Multiple Frequency (DTMF) technology control appliances from wherever the user is within the coverage area of the preferred network provider. DTMF based

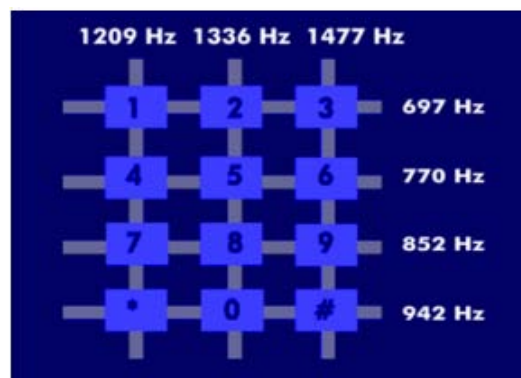

Fig. 1: Mobile phone keypad

control system implements the emerging application of DTMF tones generated from keypads of mobile cell phones to control devices and appliances from a remote area to a desired location. The research in this study focus on generating DTMF tones using a mobile phone as a transmitter another, mobile phone located at the remote location as a receiver attached to a MT8870 an integrated DTMF receiver which decodes the tones into binary output that will be processed to control several devices alongside a relay used in device switching (Fig. 1).

Corresponding Author: O. Okokpujie Kennedy, Department of Electrical and Information Engineering, Covenant University, Ota, Ogun State, Nigeria

Literature review: The literature review presented below had been critically assessed based on the research field of the project which is home automation. The account for previous work is section into five parts and in the end of each review the strengths and weaknesses of each technologies used is discussed. Our aim in the research is to provide remote control of home appliances using a technology that is improved over the existing technology.

WiFi based home automation: The home automation system that uses Wi-Fi technology was developed (Grinter *et al.*, 2005). The system consists of these components; web server which is the system core that controls and monitors user's home and hardware interface module. It also consists of the Arduino PCB (ready-made), Wi-Fi shield PCB, 3 input alarms PCB and 3 output actuators PCB.) which provides appropriate interface to sensors and actuator of home automation system. The result shows that the system is better from the scalability and flexibility point of view than the commercially available home automation systems. The technology is very expensive to deploy.

Application based home automation: The application has been developed based on the android system (Chetty *et al.*, 2007). An interface card has been developed to assure communication between the remote user, server, Raspberry Pi card and the home appliances. The application has been installed on an android smartphone, a web server and a Raspberry Pi card to control the shutter of windows. Android application on a smartphone issue command to Raspberry Pi card. The application based home automation is very suitable and user friendly but however, it is very complex and it requires expertise in programming to develop.

Cloud based home appliance monitoring system: A home gateway to collect metadata from home appliances and send to the cloud-based data server to store on HDFS (Hadoop Distributed File System), process them using MapReduce and use to provide a monitoring function to Remote user has been developed (Alliance, 2006). It has been implemented with Raspberry Pi through reading the subject of e-mail and the algorithm. Raspberry Pi proves to be a powerful, economic and efficient platform for implementing the smart home automation but it is very complex.

Smart house monitor and manager based on ZigBee: A Smart House Monitor and Manager (SHMM), based on the ZigBee was designed (Madhuri *et al.*, 2013). All

sensors and actuators are connected by a ZigBee wireless network. They designed a simple smart socket which can remote control via ZigBee. PC host is used as a data collector and the motion sensing, all sensing data are transferred to the VM in the cloud. The user can use the PC or android phone to monitor or control through the internet to power-saving of the house. The use of smart house monitor and manager is very efficient and it also provides a user friendly environment. However, ZigBee network have low data transmission rate and cannot send data over long distance and the installation of ZigBee network can be very expensive.

Arduino and ethernet based home automation: Arduino and ethernet based home automation was developed (ElShafee and Hamed, 2012a). The house network used together both wireless ZigBee and wired X10 technologies (ElShafee and Hamed, 2012b). This system followed smart task scheduling with a heuristic for the Resource-Constrained-Scheduling Problem (RCPSp). The mobile device can be either wired to the central controller through USB cable or communicates with it wirelessly within the scope of the home. Arduino contains the web server application that communicates through the HTTP protocol with web-based android application. The system is highly flexible and scalable and expandable. Despite the advantages of using Arduino based home automation the use of Ethernet with the technology has posed different challenges such as low speed, low data transmission rate and also the use of wired communication technology.

Bluetooth based home automation system: The implementation of a home automation system using bluetooth was designed (Jain *et al.*, 2014). It uses a host controller implemented on a PC which is connected to a microcontroller-based sensor and device controllers. The researchers built a new protocol on top of the bluetooth software stack, called Home Automation Protocol (HAP) to make the communication between devices possible. The device controller is connected to electronic devices through the I2 C bus. The system allows >1 device controller to be connected to the host controller. This home automation system can also be accessed remotely through GPRS. The researchers use a cellphone equipped with bluetooth connectivity as a host controller and a GSM modem that provides internet connectivity. Home devices are fitted with bluetooth communication adapters so that they can communicate with the host controller phone via. bluetooth. Despite, the advantage of the bluetooth based home automation such as low cost, easy to implement and quick to set up there are however

different disadvantages. The different issues with the use of bluetooth for home automation includes low communication range of about 100 m, high power consumption, security concerns such as eavesdropping and weak encryption (Teymourzadeh *et al.*, 2013).

Low cost AVR-based board home automation: The home automation system that uses a low cost AVR-based board (Spale, 2015). The system present a commercially available E20 evaluation board with the processor AT mega 32 serving as the main controller. Two client versions were created: an adaptive web client that makes it possible to determine the actual response using JavaScript and a specific web client for controlling a gas boiler. The system create a compact interface that uses little bandwidth to enable high transmission speed, despite the weak server.

Speech based home automation system: The use of speech to communicate remotely with appliances in the home to perform different task was developed. This was designed for the disabled to operate devices through speech. In the above related work since, the Short Message System (SMS) is used there is a disadvantage of late delivery of SMS because of traffic on the networks. Users might not be able to track what appliances is ON at a particular time. In subsequent study of this project the GSM control system will take advantage of the keypad tone hence ensuring that users track each device just by the press of a button.

Due to the limitations of the related works the research resulted in a model with higher transmission rate which is cost effective, simple and also utilizes GSM. Our system design integrates uses Dual Tone Multiple Frequency (DTMF) technology to control devices with a mobile phone used with a voice feedback device to know the status of any device at any point in time.

MATERIALS AND METHODS

The model was designed using a Dual Tone Multiple Frequency (DTMF) decoder MT8870, a Binary Converter, a crystal 3.57964 (BCG), diodes, a mobile phone, other discrete components and adaptive neuro fuzzy. The DTMF decoder MT8870 decodes the mobile signal from incoming calls from remote location by means of getting the DTMF tone from the receiver’s mobile phone speaker pins and transforms it into a four-bit binary output signal. The binary coded decimal converter converts the binary signals received from the MT8870 back to decimal form. A crystal 3.57964 (BCG) generates pulses that power the DTMF tone decoder. Adaptive neuro fuzzy is used to train the movement of signals from mobile phone to the DTMF system at home. This study is divided into five parts.

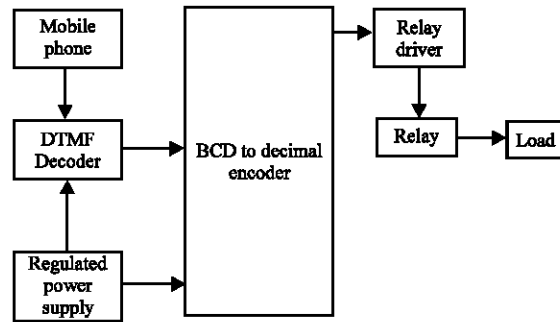

Fig. 2: Functional diagram of the DTMF based home automation system

Table 1: Design specifications of DTMF system

Parameters	Specification
Transformer	Input voltage: 240VAC Output voltage: 12 VAC Current rating: 500 Ma Turns ratio: 20
DTMF decoder	MT8870
Pulse generator	Crystal 3.57964
Voltage regulator 7805	12-5V
Filtering capacitor	A 4700 micro Farad capacitor for removing ripples
Diodes 4	Four diodes for full wave bridge rectification. They convert AC-DC

Functional architecture and design specification for the developed home automation:

The functional architecture for the developed home automation in Fig. 2 consists of the mobile phone where call is initiated and then trained using adaptive neuro fuzzy algorithm, power supply, transformer, DTMF decoder, binary coded decimal converter, a crystal pulse generator and other discrete elements.

A call is put through to the mobile device attached to the DTMF automation system. It is automatically answered and the DTMF tone is processed to control the specific device assigned to specific tones. The MT8870 is used in decoding the signals that come from the caller and converting it to binary form. The output binary code is transferred to the binary coded decimal converter which further converts binary back to decimal. This decimal is transmitted to the relay for appropriate switching. The design specification of the developed DTMF based automation system is shown in Table 1.

Adaptive neuro fuzzy system: The adaptive neuro fuzzy is a system that trains the movement of signal from one point to another in order to avoid signal loss. The design is such that the bits of the generated tone been sent from the mobile phone will be taken as the input for the adaptive neuro fuzzy system. The connecting routes, number of routes, membership function and the input from

mobile phone are all used to get the output signal. The membership function is mapped with the input which is the bits of the signal to form or get the normalized weights which is then used to calculate the output of the signal.

The output signal is compared with the threshold value to make sure the threshold value has been reached so that we can guarantee that the signal has been delivered. Once the signal is able to reach the DTMF system, connected to device at home it is a complete process without any delay.

Developed enhanced adaptive neuro fuzzy algorithm:

The proposed scheme is an hybrid system which consists of neuro fuzzy algorithm, DTMF decoder, pulse generator, BCD converter and other relevant components the following steps are involved.

- Step 1: Input the bits of the generated tone been sent from the mobile phone.
- Step 2: Process the input bit to find the normalized weight
 $w_i = \mu_{A_i}(b_1) \times \mu_{B_i}(b_2) \times \mu_{C_i}(b_3) \times \mu_{D_i}(b_4) \times \mu_{E_i}(b_5) \times \mu_{F_i}(b_6) \times \mu_{G_i}(b_7) \times \mu_{H_i}(b_8)$.
 For $i = 1, \dots, 8$, for $i = 1-8$:

$$\bar{w} = \frac{w_i}{\sum_{i=1}^S w_i}$$

Step 3: Calculate the output for the signal

$$O_i = \frac{\sum_{i=1}^S R_i \bar{w}}{\sum_{i=1}^S \bar{w}}$$

Where:

- R_i = Connecting routes
- S = No. of connecting routes
- μ = Membership function
- b1-b8 = Tone generated from the phone in bits (binary signal)
- w_i = weight of generated tone in bits
- i = Total number of bits

Hence, the threshold value must be exceeded before the signal can be said it is delivered.

Regulated Direct Current (DC) power supply: A regulated DC power supply is a simple unit that powers the home automation system. The power supply from the mains (240 v/50 Hz) is transformed to 12 V AC using a step down transformer. The 12V AC is rectified using four diodes and produced a rippled DC which is later filtered using the 4700 μ F, 50V. The voltage is regulated using a voltage regulator LM7805. Figure 3 shows the block diagram of the regulated DC power supply.

DTMF decoder (Mt8870): The MT8870 is a full DTMF Receiver that integrates both band split filter and decoder functions into a single 18-pin DIP or SOIC package. This receiver offers low power consumption with accurate data handling. Its filter section uses switched capacitor.

It includes the innovation for both the high and low filters and for dial tone dismissal. The decoder utilizes advanced methods to recognize and unravel each of the

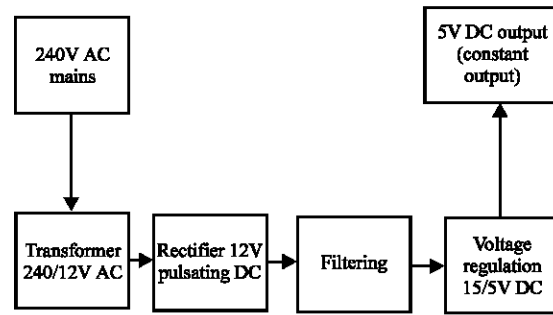

Fig. 3: Block diagram of the regulated DC power supply

16 DTMF tone sets into a 4 bit code. The decoder gives a “shut down” option which drops power utilization to 0.5 mw.

Binary Coded Decimal Converter (BCD): The BCD converter encodes the four bit binary signals generated from DTMF decoder and sends the signals to a transistor that powers the relay.

Relay: This switch operates electrically; it is majorly used where the control of a circuit is necessary with low power signal and at the same time provides complete electrical isolation between the control and the controlled circuit.

When current flows through the coil of the relay, a magnetic field is developed which attracts a lever and alters the switch contacts. The relay has two switching positions they are usually named Normally Closed (NC) and Normally Opened (NO). Therefore, the output signal from the binary coded decimal converter which is in decimal form are processed accordingly by the relay which performs the switching operation.

Performance evaluation method for home automation model: This research is evaluated using parameters such as accuracy and convergence time.

Accuracy: Accuracy (A) is computed as the ratio of the number of correctly delivered signals to the total number of signals. The A was considered for the DTMF system in Table 2. The accuracy for the enhanced home automation model is computed as follows:

$$A = \frac{T_s}{T_s + T_N} \times 100 \tag{1}$$

Where:

- T_s = The number of signal with correct delivery value
- T_N = The number of signal with incorrect delivery value

Convergence time: Convergence time is measured in terms of iterations needed to compute the correct delivery

Table 2: Parameter and simulation result of signal output for transmitting the generated tone

Generated tones	Tone in binary	No. of iterations	Output value
39	00100111	1	0.9649
28	00011100	1	0.7241
23	00010101	4	0.9459
17	00010001	1	0.9540
4	00000100	5	0.6076
18	00010010	2	0.5244
46	00101110	3	0.5648
43	00101011	5	0.1895
8	00001000	2	0.5167
34	00100010	5	0.5343

value for the transmitted signals. Convergence time is the number of iteration with respect to the route size. The set threshold value is used as the reference for its computation.

System implementation and testing: In this study, the implementation and testing of the system design is discussed. The implementation phase involved purchasing the required hardware used to successfully construct the project. In the testing phase, various parts of the project were tested using various methods to ensure that they perform optimally.

Implementation: The construction was basically a hardware construction. It entails the following.

Bread boarding of components: The various components used for the project were designed as a system on a bread board in order to ensure the functionality of every component. It was also done in order to ensure that the circuit diagram designed for the project is correct before soldering the components on the Vero board permanently.

Mounting and soldering of components: After testing components on the bread board, the components were mounted appropriately and soldered on a Vero board to ensure permanent connection between the components. This was properly done in order to avoid bridging, short circuit or open circuit problems.

Packaging: After the mounting and soldering of the various components used in the implementation of this project, it was packaged in a plastic casing with an indicator light at the top.

Testing: Various tests were carried out to monitor and verify the operations and performance of the automation system. Some of the tests include the following: unit testing integration testing and system testing.

Unit testing: The metering system consists of different units which were coupled together to obtain the whole

system. Tests on units independent of one another were carried out such as the resistance and capacitance values before circuit connections. The transformer was tested in order to ensure that it provides the necessary voltage levels when it is connected to the mains. The diodes, transistors, capacitors and resistors were also tested in order to ensure that they were functioning properly.

Power supply unit testing: The power supply unit consists of the step-down transformer the diodes, capacitors and a voltage regulator. The tests were carried out at different outputs of these components in order to ensure that they functioned optimally.

Communication unit testing: The communication unit consists of the mobile phones, MT8870 DTMF decoder IC, the BCD to decimal converter IC and the pulse generator to send pulses to the DTMF decoder. Tests were carried out to ensure proper functionality. integration testing

In order to evaluate the interaction between separate modules of the project the integration testing was carried out. This was important because the project involves the integration of several components to obtain a complete system. The test was about connecting the power supply unit and the communication section together.

System testing: System testing was done to test the complete home automation system. It entails the complete operation of the system based on the interaction between the different modules employed in implementing the project. Light bulb was used while testing the functionality of the entire system. The glowing of the light bulb signified that the entire system performed optimally as intended.

RESULTS AND DISCUSSION

Simulations were performed for enhanced home automation system steganography adaptive neuro fuzzy for eight bits in ten signals to get signal output value. Is assumed the threshold value for the simulation to be 0.5. Simulation was done under MATLAB 7.0 environment. The signal outputs were gotten by performing at most five iterations. Table 2 shows the signal output value for transmitting generated tones and Table 3 shows the simulation parameters.

Simulation for accuracy is shown in Table 2 in which the signals transmitted with more routes and less routes are delivered and it has high percentage accuracy of 90%. This is an indication that enhanced home automation is a good system for controlling home appliances in order to avoid danger at home. The generated tone which is the

Table 3: Simulation parameters

Transmitted signals	Binary	Route size
39	00100111	5
28	00011100	8
23	00010101	7
17	00010001	10
4	00000100	1
18	00010010	9
46	00101110	6
43	00101011	2
8	00001000	4
34	00100010	3

Table 4: Simulation result for convergence time

Routes	Convergence time (sec)
5	1
8	1
7	4
10	1
1	5
9	2
6	3
2	5
4	2
3	5

signal transmitted were gotten using random number generator while the routes are also generated using random numbers generator. Accuracy was calculated using Eq. 1. Result for accuracy was shown in Table 3. The simulation for the convergence time was performed using ten scenarios. It takes the number of iterations for the ten signals sent and the route size of each signal.

The result for the convergence time was shown in Fig. 2 and Table 4. Enhanced home automation system had 1-5 sec for convergence and the time that ranges between 1 and 3 is more than the time that ranges between 3 and 5, hence the system converges faster.

CONCLUSION

This research describes the design and implementation of DTMF based home automation system over a GSM network which is suitable for managing household and office devices from remote locations. Different technologies which have been used for home automation are not commercially viable and the designs are very complex. This research designs a model with improved features. The DTMF decoder MT8870 decodes the mobile signal by means of getting the DTMF tone from the receiver’s mobile phone speaker pins and transforms it into a 4 bit binary output signal. The four bit digital output signal is sent to the BCD converter for processing. It converts the four bit binary signal received back to decimal form. The output signals are processed accordingly by the relay which performs the switching operation.

The development of a Dual Tone Multiple Frequency (DTMF, 2014) based home automation system is a viable means of remotely controlling appliances and devices. Devices can be controlled from distances longer than the coverage distance of bluetooth or infrared based remote controllers. The developed model was simulated using accuracy and convergence time as performance metrics. The simulation results show that DTMF based home automation is an improved system for home automation. Future work will be to get a response from the DTMF system that the device is successfully switched on or off by using a suitable micro-controller so as to put a feedback mechanism in place.

REFERENCES

Alliance, Z., 2006. ZigBee specifications. ZigBee Alliance, Shenzhen, China.

Chetty, M., J.Y. Sung and R.E. Grinter, 2007. How smart homes learn: The evolution of the networked home and household. Proc. Ubicomp, Innsbruck, Austria, 4717: 127-144.

DTFM., 2014. DTMF explained: How does it work?. Genave, Farmington, New Mexico. www.genave.com/dtmf

ElShafee, A. and K.A. Hamed, 2012a. Design and implementation of a WiFi based home automation system. World Acad. Sci. Eng. Technol., 6: 1852-1858.

ElShafee, A. and K.A. Hamed, 2012b. Design and implementation of a WIFI based home automation system. World Acad. Sci. Eng. Technol., 68: 2177-2180.

Grinter, R.E., W.K. Edwards, M.W. Newman and N. Ducheneaut, 2005. The work to make a Home Network Work. Proc. Eur. Conf. Comput. Supported Co-Operative Work, 18: 469-488.

Jain, S., A. Vaibhav and L. Goyal, 2014. Raspberry Pi based interactive home automation system through E-mail. Proceedings of the 2014 International Conference on Optimization, Reliability and Information Technology (ICROIT), February 6-8, 2014, IEEE, New Delhi, India, ISBN: 978-1-4799-3958-9, pp: 277-280.

Madhuri, K., B.L. Sai and B.S. Sirisha, 2013. A home automation system design using hardware descriptive tools. Intl. J. Eng. Res. Technol., Vol. 2,

Obiazi, A.M.O., F.I. Anyasi, J.B. Erua, O.A. Osahenvenwen and O.K. Okokpuje, 2009. An innovative technique in switching electrical appliances: an omni-directional rf remote control switch mechanism. J. Eng. Applied Sciences, 4: 268-271.

- Panth, S. and M. Jivani, 2013. Home Automation System (HAS) using android for mobile phone. *Int. J. Electron. Comput. Sci. Eng.*, 3: 1-11.
- Samuel, J.N., O.E. Robert, S.C. Peters and O. Kennedy, 2016. Intelligent plant watering system for rural farmers. *Proceedings of the 14th International Conference on Software Engineering Research and Practice (SERP)*, July 25-28, 2016, CSREA Press, Las Vegas, USA., ISBN:1-60132-446-4, pp: 194-199.
- Spale, J., 2015. Home automation with a low-cost AVR-based board. *IFAC. Pap. Online*, 48: 398-403.
- Teymourzadeh, R., S.A. Ahmed, K.W. Chan and M.V. Hoong, 2013. Smart GSM based home automation system. *Proceedings of the 2013 IEEE Conference on Systems, Process and Control (ICSPC)*, December 13-15, 2013, IEEE, Kuala Lumpur, Malaysia, ISBN:978-1-4799-2210-9, pp: 306-309.