



Optimal Location and Size of Distributed Generation to Reduce Power Losses based on Differential Evolution Technique

Noor Izzri Abdul Wahab^{1*}, Ahmed Sahib Hammadi¹ and
Mohammad Lutfi Othman¹

¹Department of Electrical and Electronic Engineering, Faculty of Engineering, Universiti Putra Malaysia, 43400 UPM, Serdang, Selangor, Malaysia

ABSTRACT

An electric power system generate electricity to meet demands. Distributed Generation (DG) allows electricity to be generated in a small capacity where the customer is located. In this paper, multi-objective functions based on the indices of system performance are formulated and used to determine the best location. The Differential Evolution technique (DE) has been employed to calculate optimal sizing for each location. Unity power factor DG model have been studied in this work and the problems solved with one DG unit. IEEE 14 bus has been used as a test system.

Keywords: Distributed Generation (DG), Differential Evolution (DE), multi-objective function (MOF)

INTRODUCTION

Major changes in technology, environmental policies and expansion of power markets have enabled the distribution of electricity in a small capacity to power networks (Karimyan, Gharehpetian, Abedi, & Gavili, 2014). The new technology utilises both unconventional and conventional sources of energy. Often, it may be operated by the utility company

or the customer. The operation of a DG unit may be considered random depending on customer load (Aman, Jasmon, Bakar, & Mokhlis, 2012). The location and amount of power delivered from DG (Distributed Generation) units into the distribution system can either increase or decrease the efficiency and stability of the system. Therefore, it's very important to determine the optimal location and size of the DG units before they are inaugurated into the system. In the recent years, numerical calculation approach based on artificial intelligence techniques has been introduced to optimise the operations of the DG. These methods though efficient, are complex and sometimes reproduction of their results may be difficult or impossible. Earlier

ARTICLE INFO

Article history:

Received: 24 August 2016

Accepted: 02 December 2016

E-mail addresses:

izzri@upm.edu.my (Noor Izzri Abdul Wahab),

ahmed.tuky@yahoo.com (Ahmed Sahib Hammadi),

(Mohammad Lutfi Othman)

*Corresponding Author

studies have examined optimal placement and sizing and evaluation of impact of the DG unit. Adaptive genetic algorithm (GA) was used to reduce power losses and improve the voltage profile under uncertainties load in (Ganguly & Samajpati, 2015). The PSO method was used to find the best location and to determine the optimal size of DG units for improving voltage stability and reducing power losses (Khanjanzadeh, Arabi, Sedighizadeh, & Rezazadeh, 2011). The PSO method was more accurate than the GA method and the speed of convergence was also fast. Firefly Algorithm (FA) method has been employed to determine optimal location and sizing of DG units in the distribution power networks to minimise the total real power loss of system (Sulaiman, Mustafa, Azmi, Aliman, & Rahim, 2012). The Differential Evolutionary (DE) methodology was proposed to achieve optimal location, size and number of capacitor bank in the distribution networks (Karimi, Shayeghi, Banki, Farhadi, & Ghadimi, 2012). The DE method proved effective in finding the optimal size, location, and number of capacitor banks in terms of speed and accuracy of the results.

In this paper, DE optimisation technique is used to determine the best location and the optimal size of DG unit to reduce power losses and improve the voltage profile of the distribution system.

This paper is organised as follows: The five performance indices relating to DG allocation are discussed in section II. The multi objective functions with corresponding weights are discussed in section -III while optimal sizing and siting of DG unit by using Differential Evolution method (DE) is discussed in section IV. In section V, IEEE 14 bus distribution system, methodology and results of the study are discussed. Section VI concludes the paper.

OBJECTIVE FUNCTION FORMULATION

Indices show the range of system reliability and in this paper, five indices are used to determine the multi-objective function by giving weight to each index.

- 1. Real and Reactive Power Loss Index:** The real and reactive power loss indices are defined as flowing (Ochoa, Padilha-Feltrin, & Harrison, 2006):

$$LIP = \frac{P_{loss}^{with L}}{P_{loss}^{without}} \quad (1)$$

$$LIQ = \frac{Q_{loss}^{with DG}}{Q_{loss}^{without DG}} \quad (2)$$

where; $P_{loss}^{with DG}$, $Q_{loss}^{with DG}$, $P_{loss}^{without DG}$ and $Q_{loss}^{without DG}$ are the total real and reactive power losses after and before inclusion of DG units in the distribution system.

2. **Voltage Deviations Index:** One of the advantages of proper location and size of the DG is the improvement in the system voltage profiles. The voltage deviation index can be defined as:

$$VDI_i = \max_{i=2}^n \left[\frac{V_{ref} - V_i}{V_{ref}} \right] \quad (3)$$

where, V_{ref} is the voltage of the reference bus (slack bus) and n is the number of the buses.

3. **Line Loading Index:** the line flows show an increase or decrease at few existing distribution lines when the DG units are placed in the distribution system. The line loading index definition is from: (Seifinajmi & Sakhavat Sagh, 2014)

$$LLI_i = \max \left(\frac{S_j^{DG}}{S_j^0} \right)^{nl} \quad (4)$$

where, S_j^{DG} and S_j^0 are the power flows at the branch j with and without DG. nl is the number of the branches.

4. **Short Circuit Index:** This index is related to the protection and selectivity issues where it evaluates the maximum short-circuit current variation of the system in two scenarios, with and without DG (El-Zonkoly, 2011).

$$SCI_i = \max \left(\frac{I_{sc_i}^{DG}}{I_{sc_i}^0} \right)_{i=1}^{nb} \quad (5)$$

where, $I_{sc_i}^{DG}$ and $I_{sc_i}^0$ are the symmetrical fault current contributions at node i with and without DG.

The indices proposed in this paper are subject to the following quality and inequality operational constraints:

Voltage limits: The voltage drop limits depend on the voltage regulator limits provided by the disco (Kumaraswamy, Tarakalyani, & Prasanth, 2014).

$$V_{min} \leq V_i \leq V_{max} \quad (6)$$

Line Thermal limits: Power flow through any distribution feeder must comply with the line thermal capacity.

$$S_i \leq S_{i,max} \quad (7)$$

DG capacity: This section defines the boundary of power generator by DG:

$$P_{min}^{DG} \leq P_i^{DG} \leq P_{max}^{DG} \tag{8}$$

MULTI OBJECTIVE FUNCTION FORMULATION

By calculating the five indices described in the previous section and taking corresponding weights for each index, the Multi-objective Function can be expressed as in equation 9 (Mancer, Mahdad, & Srairi, 2012).

$$MOF = w_1LIP + w_2LIQ + w_3VDI + w_4LLI + w_5SCI \tag{9}$$

The sum of the absolute values of the weights assigned to all indices should add up to one as shown in the following equation:

$$w_1 + w_2 + w_3 + w_4 + w_5 = 1 \tag{10}$$

The weight values vary according to concerns of engineers and the importance of electrical standards. Additionally,, the weight values are specified to give importance to each index depending on the system. The index that outperforms the others in terms of benefits and importance is given a larger weight.

DE METHOD FOR OPTIMAL DG ALLOCATION

The DE technique is one of the evolutionary computation methods which depends on stochastic real parameter algorithms. It is used to solve nonlinear, non-differentiable and multimodal objective functions (Kenneth, 1999). The DE is uses a less stochastic approach and a greedy selection compared with other classical EAs to solve optimisation problems. The basic steps of the standard DE algorithm are described as follows:

Step 1: Initialisation. The first operation of the DE algorithm is randomly initiated population (NP) of D-dimensional parameter vectors. These vectors represent a candidate solution to solve the optimisation problem. The initial population can be expressed as:

$$X^1 = [X_1^1, X_2^1, \dots, X_i^1], (i = 1, 2, \dots, N_p) \tag{11}$$

$$X_i^1 = X_{lower} + (X_{upper} - X_{lower})RM_i^1 \tag{12}$$

where, (X_i^1) is a D-dimensional vector, and $RM_i^1 = [rm_{i,1}^1, rm_{i,2}^1, \dots, rm_{i,D}^1]$.

Step 2: Mutation. Three distinct parameter vectors are sampled randomly from the current population to create donor vectors; these indices are generated once for each mutant operator. The scale of difference between two vectors is added to the third one. The mutation strategy is expressed as:

$$V_i^g = X_{best}^g + F(X_{r1}^g - X_{r2}^g) \tag{13}$$

where, X_{r1}^g, X_{r2}^g are the randomly selected vectors among the population, X_{best}^g is the vector with the best fitness value among the individuals, F is a scaling factor.

Step 3: Crossover. In crossover operations, the donor vectors $V \rightarrow_{iG}$ reciprocate with the target vectors $X \rightarrow_{iG}$ to create the trial vectors $U \rightarrow_{iG}$. The trial vectors $u_{(j,i,G)}$ can be formulated as:

$$u_{i,j}^g = \begin{cases} v_{i,j}^g, & \text{if } (rm_{i,j}^g \leq CR) \text{ or } j = rm_{i,j}^g \\ X_{i,j}^g, & \text{if } (rm_{i,j}^g > CR) \text{ and } j \neq rm_{i,j}^g \end{cases} \tag{14}$$

where, $u_{i,j}^g$ is a component of $U_{i1}^g = u_{i,1}^g, u_{i,2}^g, \dots, u_{i,D}^g$

Step 4: Selection. After the crossover process, the generated trial vector may be chosen to be a member of the next generation based on the selection criteria, which is given by:

$$X_i^{g+1} = \begin{cases} U_i^g, & \text{if } fitness(U_i^g) < fitness(X_i^g) \\ X_i^g & \text{otherwise} \end{cases} \tag{15}$$

RESULTS AND DISCUSSIONS

Test System

The DG unit was assumed to be integrated in an IEEE 14 bus test system. Figure 2 shows the single line diagram of IEEE 14-bus test system which consists of 5 generator buses, 9 load buses and 20 branches. The total real load of the system is 259 MW and reactive load is 112 MVar. The real and reactive power losses in the base case of IEEE 14 bus test system obtained using Newton Raphson method is 13.5929 MW and 56.9096 MVar respectively (Pai, 1979).

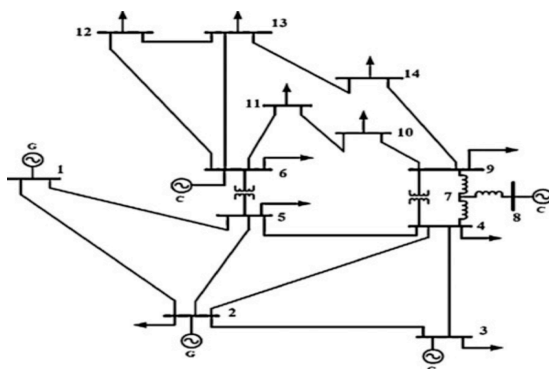

Figure 1. Single line diagram of IEEE 14 test system

Weights Values

The values of weights in multi-objective function are different based on the engineer's concern. In general, it is not easy to identify suitable weight values for each index. Engineers and operators of plants who have experience with distribution systems should be able to identify the suitable values of the weights. During this study, the values of the weights were assumed positive and W_1 related to active power losses is restricted between 0.35 and 0.50, W_2 related to reactive power losses is restricted between 0.1 and 0.30, W_3 related to voltage division is restricted between 0.1 and 0.30, W_4 and W_5 related to capacity of line and short circuit level are fixed at 0.10 (see Table 1).

Table 1
Set of weights with corresponding fitness values

Set No	W1	W2	W3	W4	W5	Best fitness
1	0.35	0.20	0.25	0.10	0.10	0.758131
2	0.35	0.25	0.20	0.10	0.10	0.805079
3	0.35	0.30	0.15	0.10	0.10	0.852028
4	0.35	0.15	0.30	0.10	0.10	0.711182
5	0.40	0.20	0.20	0.10	0.10	0.805079
6	0.40	0.30	0.10	0.10	0.10	0.898977
7	0.40	0.10	0.30	0.10	0.10	0.721182
8	0.40	0.25	0.15	0.10	0.10	0.852028
9	0.40	0.15	0.25	0.10	0.10	0.758130
10	0.45	0.20	0.15	0.10	0.10	0.852028
11	0.45	0.15	0.20	0.10	0.10	0.805079
12	0.45	0.10	0.25	0.10	0.10	0.758130
13	0.45	0.25	0.10	0.10	0.10	0.898977
14	0.50	0.15	0.15	0.10	0.10	0.852028
15	0.50	0.20	0.10	0.10	0.10	0.898977
16	0.50	0.10	0.20	0.10	0.10	0.805079

From Table 1, set number 4 which shows the minimum fitness function is selected as a weighting set for MOF eq. (9). Thus, the weights for each index are described as $w_1=0.35$, $w_2=0.15$, $w_3=0.30$, $w_4=0.10$ and $w_5=0.10$.

Results Considering DG

In order to find the best place for DG units and their respective optimal sizes in the system, the buses that have minimum fitness values will consider their respective size. The results obtained by using DE method are tabulated and shown in Table 2.

Table 2
Optimal DG size with respective fitness value

Bus No.	Fitness	DG size MW	Bus No.	Fitness	DG size MW
4	0.7109	25.977	11	0.7203	25.7435
5	0.7311	25.6087	12	0.7283	25.9943
7	0.7100	25.6194	13	0.7124	25.7466
9	0.7090	25.8660	14	0.7034	25.9220
10	0.7153	24.3677			

From Table 2, the best three locations with minimum fitness values based on their respective optimal sizes were selected to become candidate buses to install the DG unit in their test system. The associated power losses and voltage levels for each candidate bus are determined using Newton Raphson load flow based on the optimal size of the DG unit. The results are compared in Table 3.

Table 3
Total power losses of the test system with DG

Bus No	DG size MW	Total Real losses MW		Total Reactive losses MVar		Percentage of reduction	
		Without DG	With DG	Without DG	With DG	P	Q
9	25.8660		10.956	44.141	19.4%	22.4%	
7	25.6194		10.925	45.577	19.6 %	19.9 %	

From Table 3, it is clear bus 14 is an optimal location to install DG unit in the test system according to the percentage of loss. The total real power loss is 10.738 MW (21% loss) while the reduction of the reactive power loss is 43.426MVar (23.9% loss). Table 4 provides optimal location details.

Table 4
Optimal location details of system with DG

Optimal DG location	Optimal DG size	Parameter of optimal DG location and size						Total real losses	Total reactive losses
		LIP	LIQ	VD	LLC	SC	MOF		
14	25.922	0.799	0.775	0.047	0.946	1.038	0.7072	10.738	43.426

The values of LLC and SCI were increased by an acceptable amount from (0.831) and (0.725) in the normal case to become (0.946) and (1.038) after adding the DG units. Therefore, it is necessary to update the protection devices after including DG units with the distribution system. The voltage levels of test system were increased after including the DG unit within the acceptable limits (0.95-1.1p.u) for generating buses and (0.95-1.05) for load buses (Alsac

& Stott, 1974). Table 5 compares voltage in two cases, without DG and with DG located at the best place with optimal size determined by DE method.

Table 5
Voltage profile of test system

Bus No.	Type of Bus	Voltage profile		Bus No.	Type of Bus	Voltage profile	
		Without DG	With DG			Without DG	With DG
1	generating	1.0600	1.0600	8	generating	1.0800	1.0800
2	generating	1.0450	1.0450	9	load	1.0305	1.0372
3	generating	1.0100	1.0100	10	load	1.0299	1.0355
4	load	1.0131	1.0183	11	load	1.0461	1.0490
5	load	1.0165	1.0212	12	load	1.0432	1.0452
6	generating	1.0700	1.0700	13	load	1.0466	1.0485
7	load	1.0456	1.0472	14	load	1.0192	1.0426

The DE method improves the voltage levels of almost all buses while ensuring that no voltage level rises above the acceptable limit. Figure 2 provides a comparison.

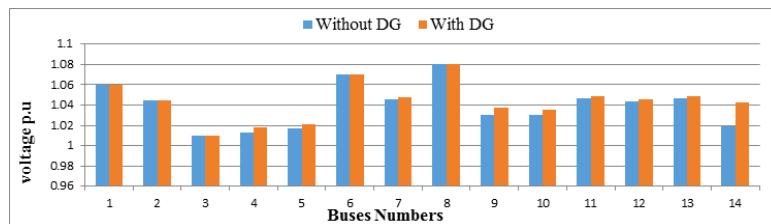

Figure 2. Voltage profile comparison

CONCLUSION

Optimal size and suitable location of DG unit that supply only active power (Type 1 DG unit) to the system have been addressed in this paper. The best locations and optimal sizes have been identified by minimising the multi-objective index using artificial intelligence methods. Among the many different heuristic optimisation algorithms, DE provides better results in terms of reduction in real and reactive power losses and improving the voltage profile of the distribution system. Reduction in the real power loss is 21% while reduction in the reactive power losses is 23.96%. The voltage level of bus 14 is increased from 1.019 to 1.0426 after integration with the DG unit.

REFERENCES

Alsac, O., & Stott, B. (1974). Optimal load flow with steady-state security. *IEEE transactions on Power Apparatus and Systems*(3), 745-751.

- Aman, M., Jasmon, G., Bakar, A., & Mokhlis, H. (2012). Optimum capacitor placement and sizing for distribution system based on an improved voltage stability index. *International Review of Electrical Engineering-Iree*, 7(3), 4622-4630.
- El-Zonkoly, A. (2011). Optimal placement of multi-distributed generation units including different load models using particle swarm optimisation. *IET generation, transmission & distribution*, 5(7), 760-771.
- Ganguly, S., & Samajpati, D. (2015). Distributed generation allocation on radial distribution networks under uncertainties of load and generation using genetic algorithm. *IEEE Transactions on Sustainable Energy*, 6(3), 688-697.
- Karimi, M., Shayeghi, H., Banki, T., Farhadi, P., & Ghadimi, N. (2012). Solving Optimal Capacitor Allocation Problem using DE Algorithm in Practical Distribution Networks. *Przeegląd Elektrotechniczny*, 88(7a), 90-93.
- Karimyan, P., Gharehpetian, G., Abedi, M., & Gavili, A. (2014). Long term scheduling for optimal allocation and sizing of DG unit considering load variations and DG type. *International Journal of Electrical Power & Energy Systems*, 54, 277-287.
- Kenneth, V. (1999). Price, An introduction to differential evolution, New ideas in optimization: McGraw-Hill Ltd., UK, Maidenhead, UK.
- Khanjanzadeh, A., Arabi, M., Sedighzadeh, M., & Rezazadeh, A. (2011). Distributed Generation Allocation to Improve Steady State Voltage Stability of Distribution Networks Using Particle Swarm Optimization and Genetic Algorithm. *Canadian Journal on Electrical and Electronics Engineering*, 2(6), 250-254.
- Kumaraswamy, I., Tarakalyani, S., & Prasanth, B. V. (2014). Optimal Location of Distributed Generation on Radial Distribution System for Loss Reduction and Voltage Profile Improvement.
- Mancer, N., Mahdad, B., & Srairi, K. (2012). Multi objective optimal reactive power flow based STATCOM using three variant of PSO. *International Journal of Energy Engineering*, 2(2), 1-7.
- Ochoa, L. F., Padilha-Feltrin, A., & Harrison, G. P. (2006). Evaluating distributed generation impacts with a multiobjective index. *IEEE Transactions on Power Delivery*, 21(3), 1452-1458.
- Pai, M. (1979). Computer techniques in power system analysis EJ. *Tata McGraw-Hill Pub Co Ltd*, 1, 979.
- Seifinajmi, E., & Sakhavat Saghi, M. N. (2014). Optimal Placement of DGs in Radial Distribution Systems Considering Power Quality Improvement and Reduce Losses. *Bull. Env. Pharmacol. Life Sci*, 3, 37-41.
- Sulaiman, M. H., Mustafa, M. W., Azmi, A., Aliman, O., & Rahim, S. A. (2012). *Optimal allocation and sizing of distributed generation in distribution system via firefly algorithm*. Paper presented at the Power Engineering and Optimization Conference (PEDCO) Melaka, Malaysia, 2012 Ieee International.

