

Designing for Human

Ahmad Rizal Abd Rahman

Industrial Design Department is one of the three departments in the Faculty of Design and Architecture in UPM. It was established in the year 2000 when the first student intake for the Industrial Design program took place. Since then, the department has developed and successfully graduated more than 300 professional designers, equipped with significant design knowledge and relevant design skills, ready to face the challenge real world. During their study, students are exposed to various design experience to assist them in producing new products as well as to be competent to generate quality products for local and international market. In current situations, most of their design outputs have been exposed and evaluated either in local or international competitions, exhibitions and seminars.

Successful designed products come from many forms and sources of inspirations. One important element in early investigation to develop new design and product is by conducting User Research. In many conventional design processes, designers still depend on ideas from prominent experts. In addition, they need information and ideas to understand about users to develop concrete problem statements and issues for their new designed project. To explore users' needs and wants, the design methods include User Centred Design, Participatory Design and Contextual Design so that designers would be able to create inspiring designs that are holistic and interesting. These 'methods' in designing encourage design students to spark new ideas and to develop product designs for the real world according to current needs, demands and situations.

To link with the real situation, the Final Year students were engaged with a specific group of users and community in the early stage of design to determine their focus on user requirements and their environment before beginning the design process. These activities on user engagement were intended to develop their understanding about a product from users' perspective. Furthermore, they create many possibilities from users about the product before the sketching and design development processes. Their understanding about users will developed better understanding about design aspects in term of ergonomics, material, colour, behaviour, culture, emotion, etc. which cannot be determined if they work within the studio environment.

Information on users and their environment could lead to creative and innovative development of new product design which can be observed through the production of their full scale prototypes and models. These new products have been granted IPRs and have won several medals in Research, Design and Innovation competitions at national level. These achievements illustrate that the products do possess high potential for commercialization in the near future.

Jury Review

Omar Bidin

The term 'design' is defined as a creative activity which, at its completion, determines the multi-faceted qualities of objects, processes, services and systems in their life cycles. In the discipline of design, any particular life cycle encompasses the many stages related to the objects/processes/services' conception, production, utilization and finally waste management and/or recycling. Industrial design, on the other hand, is a sub-category of the art and design field which focuses on designing for a better life; for both users and the ecosystem.

In the 2005 World Summit, the industrial design fraternity was given a new responsibility; to sustain the 'three pillars': ecology, social equity and economic demands. This event reinforces the general principles of industrial design which require designers to practise critical research and design development; both in the interest of human beings and the world's ecosystem.

In addition to that, the agenda of social design, which among others was inspired by Victor Papanek's idea, view designers and creative professionals as having responsibility and potential to initiate real changes in the world through

good design; not to merely sustain current conditions but to create improvements. In short, industrial designers nowadays are accountable not just for users' or clients' needs but also for the advancement of society, community and ecological framework.

In reference to the students' work in this current review, some level of careful ideation, idea development and detailing is seen to be present in their research processes, problem statement and the translation of its findings into a working model. While it is highly commendable that the students have displayed efforts in addressing issues pertaining to the environment, other issues could have also been investigated in working towards a more well-rounded approach to sustainability, such as those of social and economic nature.

Lastly, the students are also seen to have involved themselves in various related design fields from graphic, product, furniture to exhibition design. The experiences they gained have evidently given them the knowledge and confidence in becoming highly competent future professional designer.



Jury Review

Futom Shikh Jaafar

Burst of ideas! These are the words to describe the works that are presented by these students. Obviously they have engaged themselves with their surroundings to enable such pertinent ideas to be explored further.

The proposed designs are evidence of the critical observations made by the students while exercising their passion for not only sustainability but also multi-purpose, human interface/interaction, societal well being and of course economic progress.

The proposed designs are evidence of the critical and detail observations made by the students on issues such as health, comfort, safety, ease of use and simplicity. Taking the chair cum exercise equipment for the elderly as an example, it is apparent that the designer has conducted almost an exhaustive research and study in order to propose such a well thought chair that not only serves its traditional purpose for sitting but has been cleverly designed with a rotating seat to act as an exercise tool for the waist especially for the elderly. It may also be used as a physical therapy treatment. Looking at the simplicity of this product that may impact on the elderly society as well as other invalids, it surely has great market potential.

Similarly on the anti flood storage, the student has turned nature's wrath unto itself. Using the disaster to fight itself, it is very clever indeed. The product itself still offers room for improvement especially in terms of user experience, presentation, functionality and logistic. This recommendation arises from a layman's observation on the current scenario

in flood prone areas where people are more or less already prepared for such recurring natural disaster.

It is also indeed very inspiring for the small and medium companies especially livestock farmers to be presented with an innovative, simple and yet practical alternative solution in preparing livestock feed. This work by the student is translating the government's aspiration to increase the country's household income through better quality industrial products. In this case more hygienic livestock feed can be produced at a faster rate thus leading to an increased number of healthy livestock in shorter time. Some improvement is proposed on the design of the compressor plate and the length of the arm including the foot pedal. This is to ensure a better market potential among the related industry players.

Based on market observation, insect repellent products have been upgraded to be more universal in terms of their application. The decision to make the product design more universal is to enable it to be placed at various locations and yet still maintains its function while being presentable. The work of the student seems to be suggesting a complete product that includes the special table with additional accessory to insert the insect repellent container. Unless this special table is tailor-made for restaurant or the likes, there is much reservation on the application and economy of scale of this project.



Vocio (Child Rocker)

Siti Mastura Md Ishak & Azrol Kassim

Human factors and social cognition are the driving forces in designing this functional-tangible product. It also requires an embedded understanding of human-physical system within the principles of science and technology. This project involves a critical view on the issues of comfort, safety, practicability and personal taste when designing for children who are fragile and meticulous consumers. An in-depth research was carried out on the addressed issues by assessing the design of current child rockers, parent preferences and child (user) comfort and safety. The study found that conventional child rocker has some inadequacies due to the eccentric placement of the overhead bar, impractical product parts assembly and inviable product size which often cause issues with carriage and storage as well as child's safety. The study further proceeded with the design and development of a child rocker with detailed

considerations on practicality and utility aspects. The final goal of developing this design is to resolve user-centric issues which are central to the research. The new concept delivers a modern appeal by incorporating futuristic elements comprising of the state-of-the-art functionality, safety, society demands and individual personal taste. Convergence of technological features made available by this product will support user's acceptance. Hence, this project dedicates its research findings in implementing novel qualities to the new child rocker that features substantial improvements over existing baby rocker's designs.



Ahmad Qadri Basri@Boseri
ID registration: MY 12-00943-0101
Award: Silver PRPIUPM 2012
Co-inventors: Azrol Kassim & Ruhaizin Sulaiman

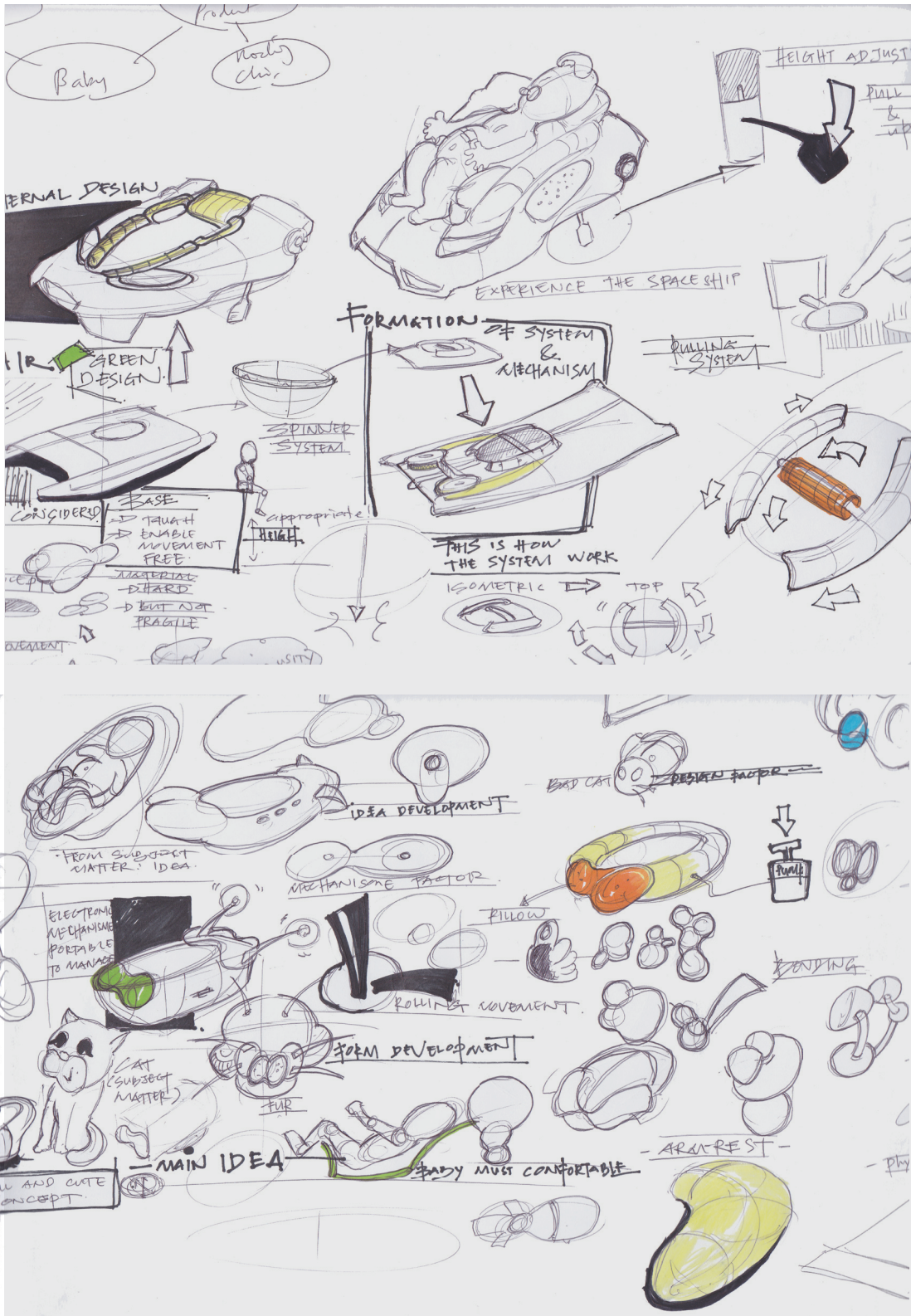

HEMOR (Sustainable Herbal Mosquito Lamp Repellent)

Ruhaizin Sulaiman

One of the most serious and deadly infected diseases in Malaysia is dengue fever. This disease is transmitted by Aedes mosquitoes. It is a flu-like viral disease which spreads from one person to another via a bite from an infected Aedes mosquitoes. Sudden dengue haemorrhagic fever usually starts with a high fever, rashes, severe headaches, joint pains and could lead to death within two weeks after being infected if not treated. Although Local Authorities and Ministry of Health have increased efforts in controlling the Aedes population, designers could also assist in mitigating this national issue.

For this reason, HEMOR is designed based on a guided research conducted earlier before the ideation process started. The product uses the facts that mosquitoes could be repelled by yellow lighting, herbal odour and others. Besides its main aim to protect lives, this artifact could also function as a decorative product to enhance the

interior of a house or space. The conceptual design is the most vital stage of the product creation. Since it defines the success or failure of the product usability, many ideas have been generated and expanded based on the data and design criteria that included forms and shapes.

After a number of critique sessions, many issues such as function, usability, commercial value, pros and cons of each idea, styling and so forth were explored. Concept 6 was selected as it fulfilled the criteria and deemed as the best design. This was followed by building a few mock-ups to measure the appropriateness of the concepts with the product criteria. Detailed design was next producing technical drawings, exploded views and renderings. The final process, which was the most challenging step, was transforming a 2D drawing into the fabrication of a 3D full size prototype.

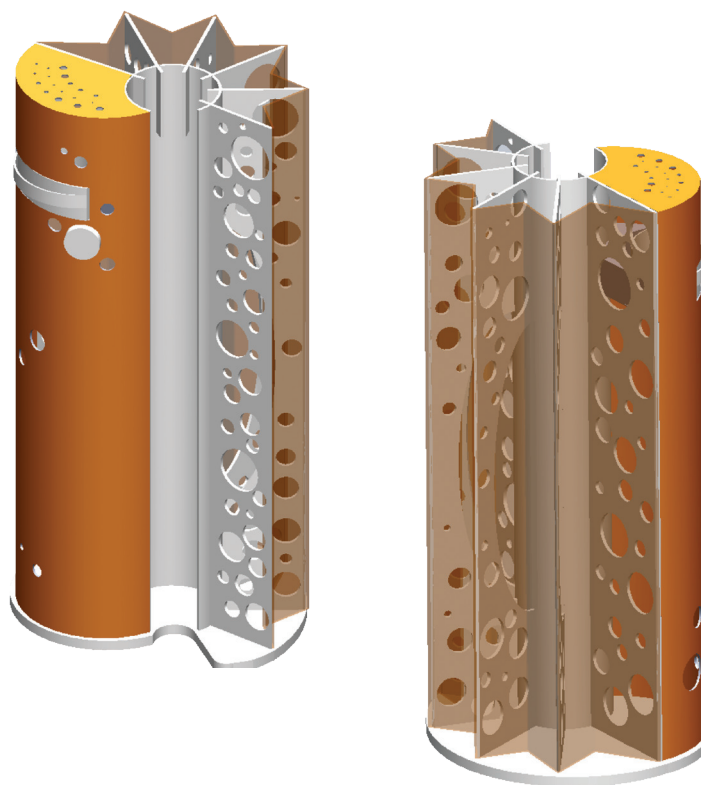

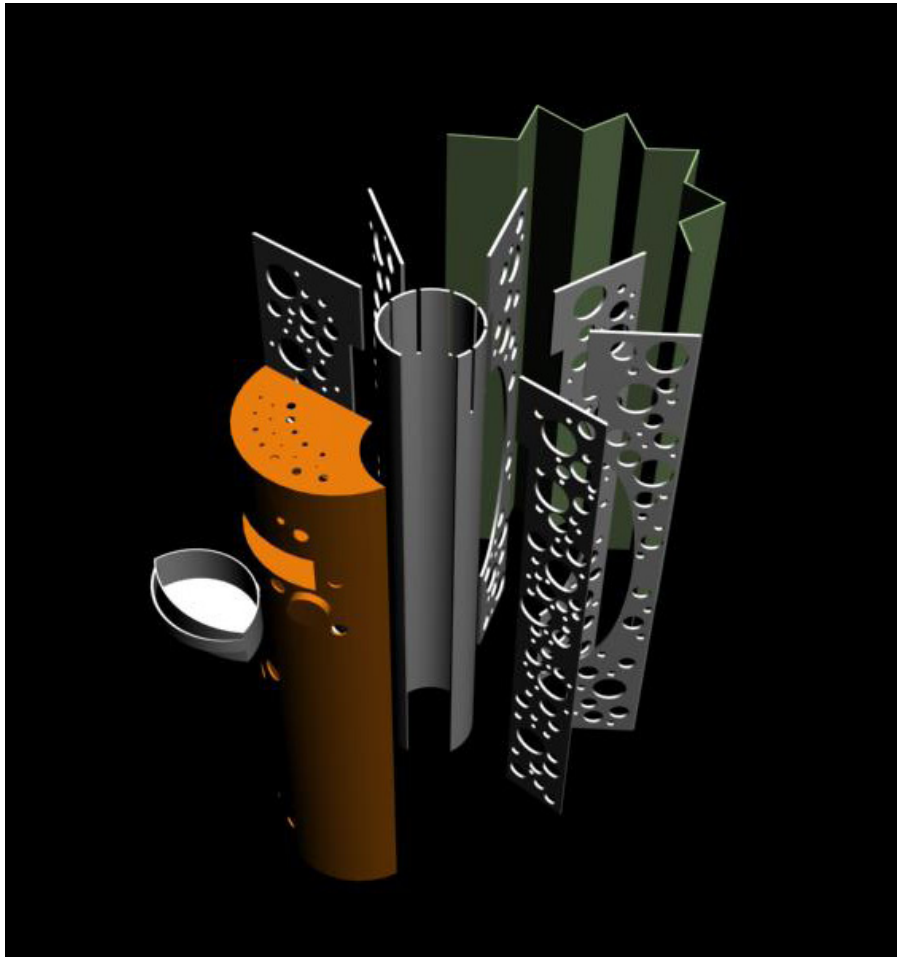

Tee Kai Xin
 ID Registration : 12-00835-0101
 Award : Bronze - PRPIUPM 2012
 Co-inventors : Raja Ahmad Azmeer Raja Ahmad Effendi







STEDDEX '12

BOXXF (Motorcyclist Safety Compartment)

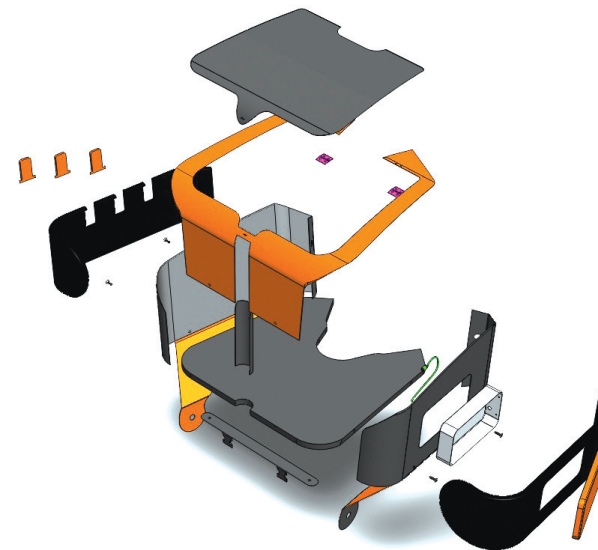
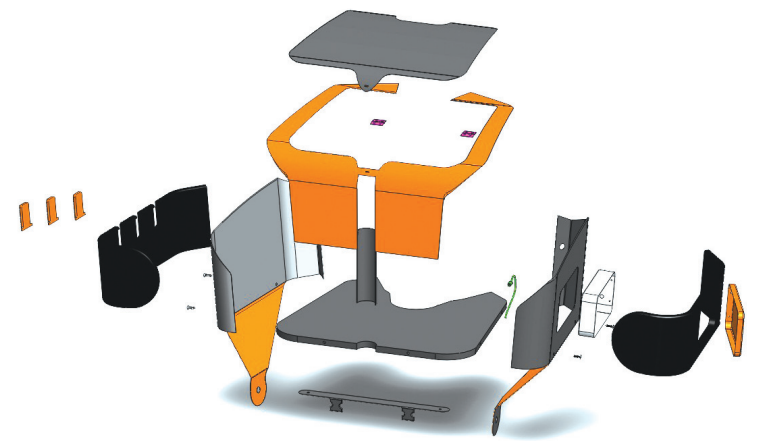
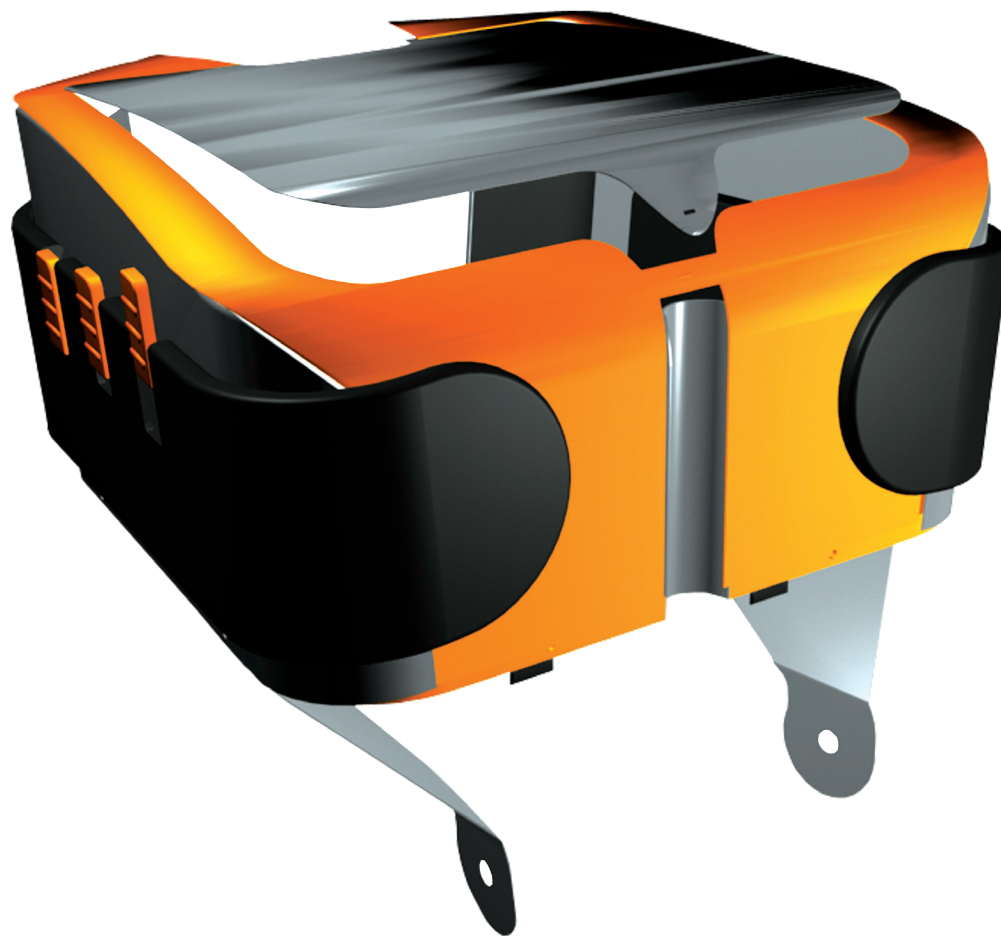
Raja Ahmad Azmeer Raja Ahmad Effendi



 Hoo Jun Hui
 ID registration: 12-00945-0101
 Award: Gold PRPIUPM 2012
 Co-inventors: Zulkifli Muslim & Mohammad Yazah Mat Raschid



In Malaysia, there is a rapid annual increase of snatch thief incidents among the public in urban areas especially among motorcyclists. In their normal modus operandi, snatch thieves will either slash the victim's bag or pocket with a razor blade and collect the victim's valuables or often try to take something away from the victim by grabbing valuable things in the motorcycle compartment through violent and quick movements. Such incident would cause many victims suffering physical as well as psychological trauma. It is regretful that a number of similar incidents had led to the death of victims.

A qualitative and quantitative research method has been carried out in solving issues focusing on the motorcycle compartment snatch crime. The findings show that a locking system for the motorcycle's compartment is an absolute necessity to prevent snatch incidents from occurring. Therefore, an alternative design for the motorcycle compartment is produced. The new design which incorporated upper closing part fitted with a locking system was redesigned to fit the front storage compartment of Moped motorcycles.

The Moped motorcycle was chosen due to the increasing number of Moped riders in Malaysia. Based on the idea and concept development, an interesting form was finalized which portrayed a futuristic design appearance with ergonomics considerations. Besides having an impressive styling and lockable compartment, multifunctional features have been added such as plastic bag hanger, wireless box, cellular phone charger and side release adjustable buckle strap to hold a folded rain cloth. Moreover, by providing a fresh new pallet of trendy colors, the contrasting colors applied on this product will attract user's attention and gives cues on how it can be operated.

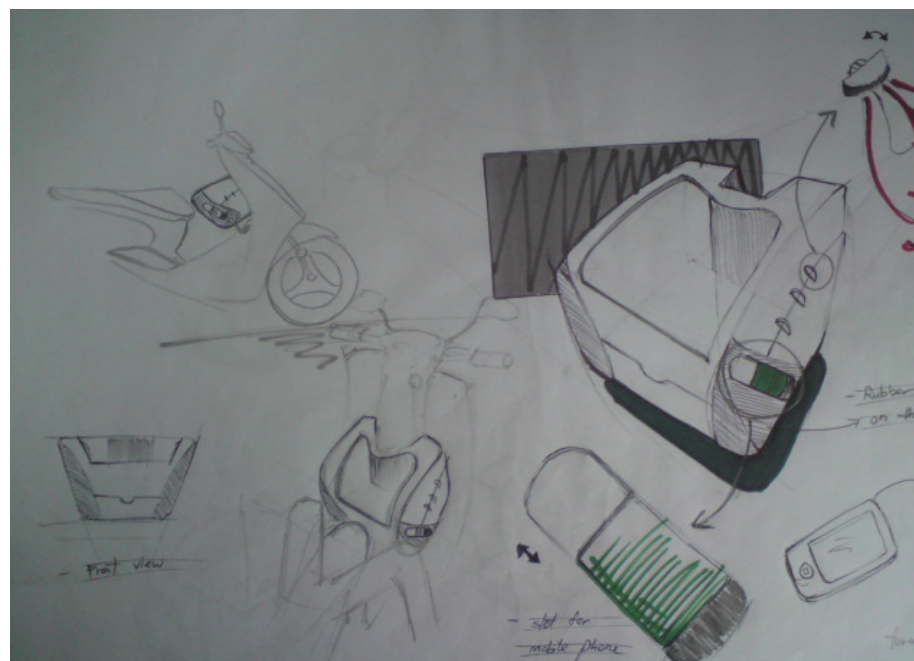
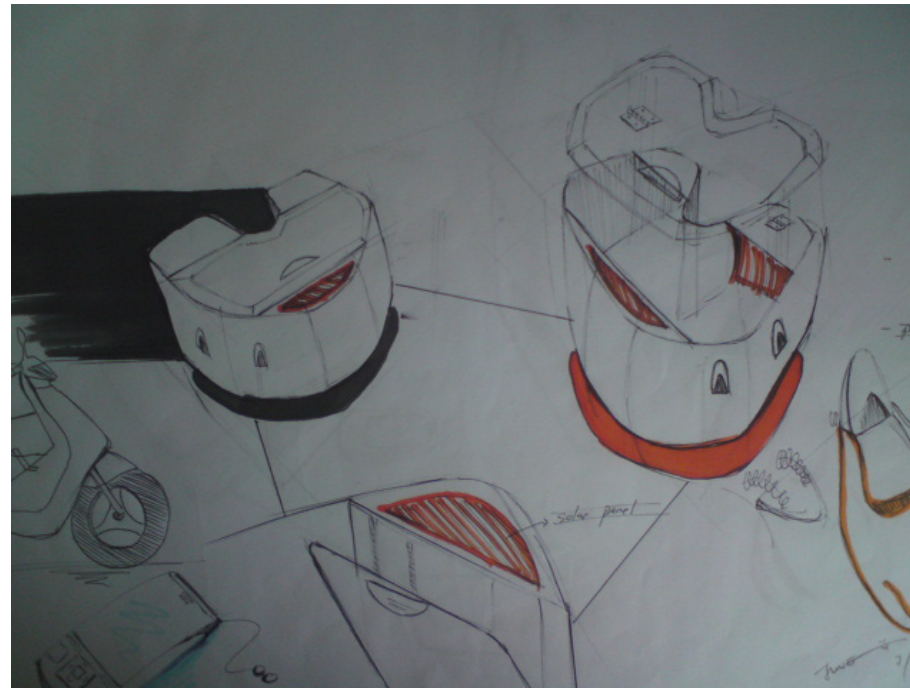

Congrex (Public Benches For Park)

Ahmad Rizal Abd Rahman

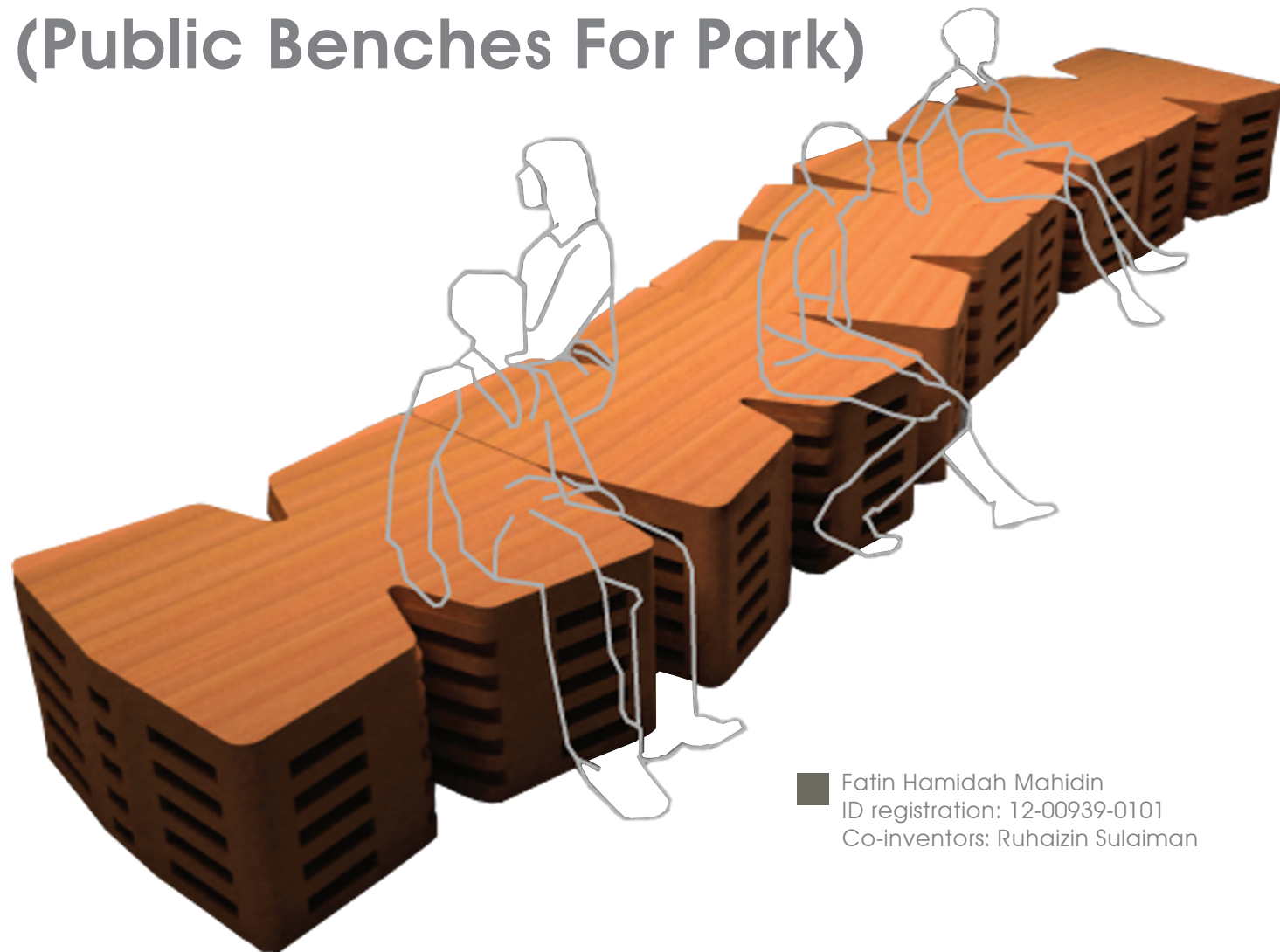

Fatin Hamidah Mahidin
ID registration: 12-00939-0101
Co-inventors: Ruhaizin Sulaiman

Furniture design basically has the aim to fulfil the needs of people for comfort, in particular to sit and relax. With current global competition and ever changing needs and trends, outdoor furniture has been designed to fulfil these trends in order to suit its surrounding in addition to complying with the environment and its sustainable conditions. In the current environmental settings of park furniture design especially for Malaysia, the study found that there are users who come to use a bench in a public park to congregate or chat and also as a place to relax their mind and body. Due to its comfort and 'homely' type design of furniture, some park furniture are also found being used as a shelter for homeless people or drug addicts. Regretfully, they would led to misuse of these furniture. Some furniture may be too colourful and utilized 'fancy' designs concept which did not comply with human behaviour in the park and its

natural surroundings. Material used and the design style of the bench should educate users on how the product can be utilized. A friendly product for the parks could definitely provide convenient space and flexible seating for users while they are sitting and enjoying the park. In designing a concept for this public bench, 'Congrex' emphasizes all the above considerations.

A precedent study was conducted in several selected dominant parks in Kuala Lumpur. The study was conducted using three methods: collection of information using questionnaire, observation on the product usage and synthesis of bench designs in public parks. Two essential aspects have been considered: the characteristics of bench design with regards to human behaviour in parks and the materials used for the existing

bench. Results from these were analysed to determine an appropriate bench design by considering its suitability and effectiveness. The study also explored suitable materials to be used such as rubber woods or other reinforced local wood material, which are durable, more practical for manufacturing and usage, and also economical for marketing purposes.

The choice of natural colour for the furniture has to be in harmony with its surroundings and environment. The design attempts to naturally blend the furniture with the park environment. The size and weight of the product are also studied to allow flexible sitting positions, encourage social interaction between users, and comply with safety and security measures.

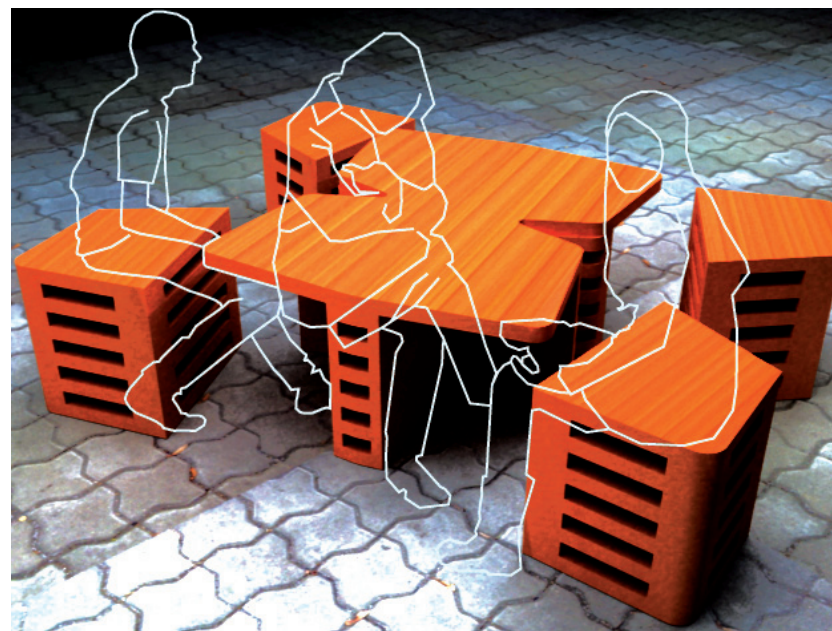
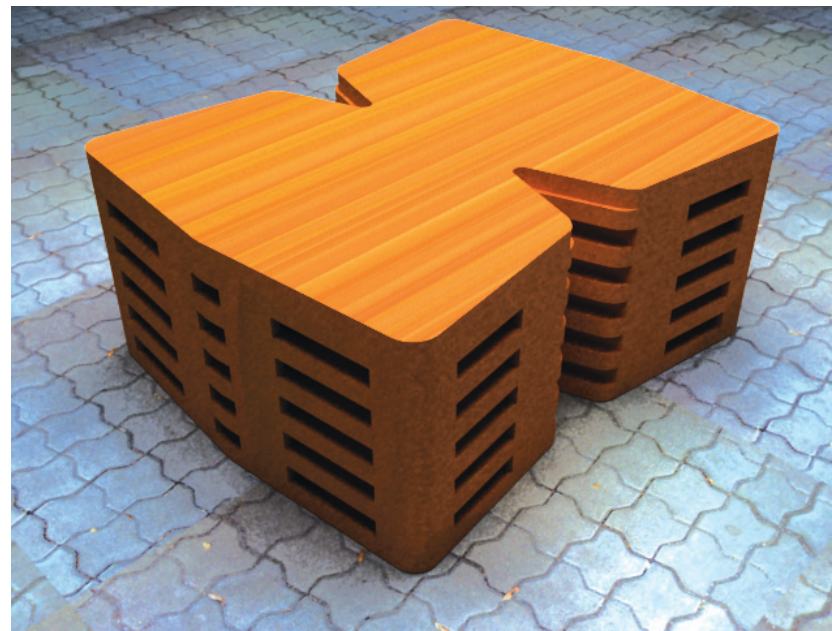
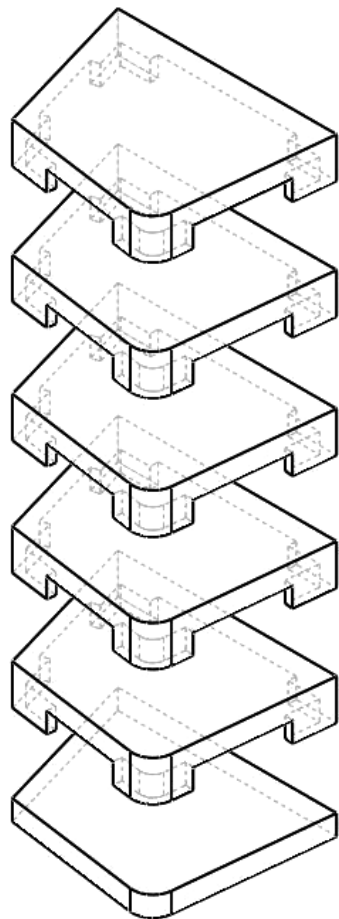

Anti Flood Storage (XF Storage)

Sazrinee Zainal Abidin

Sustainable design products are intended not to seriously impact the environment either during the creation process or when they are being used. These products are also often designed to allow the users to feel more connected or relate close to the natural environment. The Anti Flood Storage (XF Storage) design was based on the Archimedes principle that applies to objects with density: "If the density of the object is greater than that of the fluid, the object will sink; if the density of the object is equal to that of the fluid, the object will either sink or float; and if the density of the object is less than that of the fluid, the object will float".

This product is deemed suitable for flood-prone areas in Malaysia where flooding incidents often cause damages to properties. XF Storage was designed to assist flood victims to reduce property losses. The use of HDPE (High-density polyethylene) for the container and PVC (Polyvinyl chloride) for the wall will ensure its durability and sustainability. The durability of the material combined with sophisticated design functions will protect the property from being damaged by water. The waterproofing advantage and floating ability will definitely make XF Storage easier to move valuable items during flood and other emergencies.

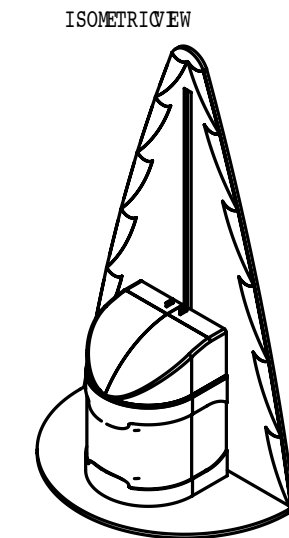
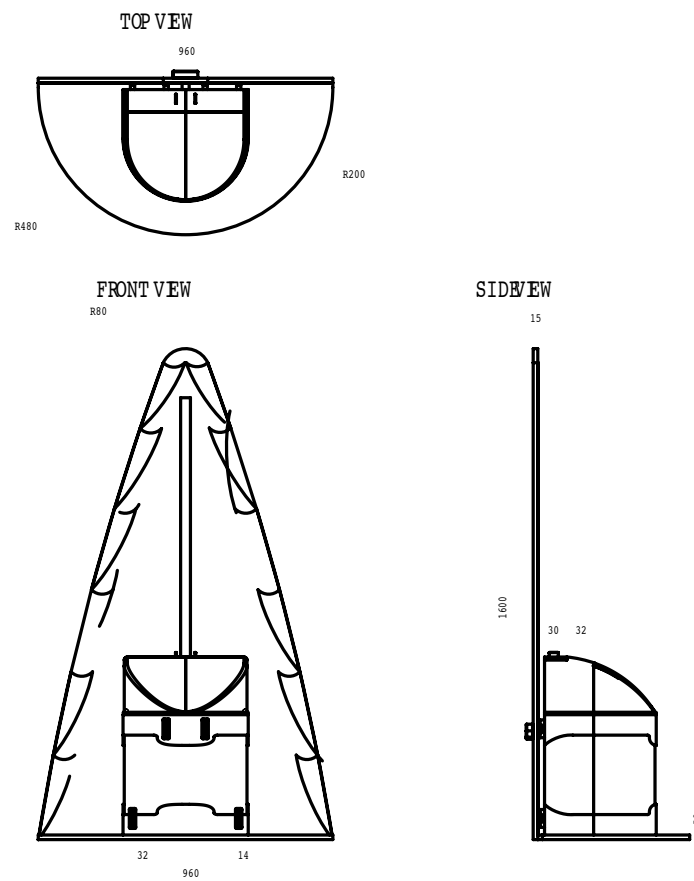

Earnie Suziyana Abdul Mucod
 ID registration: 881202-01-5204
 Co-inventors: Khairul Manami Kamarudin & Norsidah Ujang

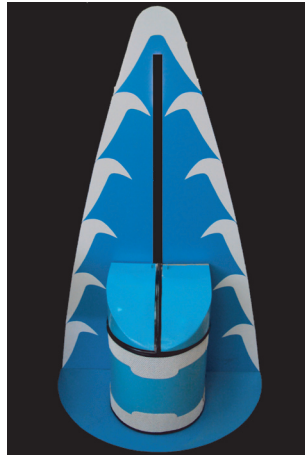

Anti flood storage floating if flood happen.



Storage have durable material and water proof.

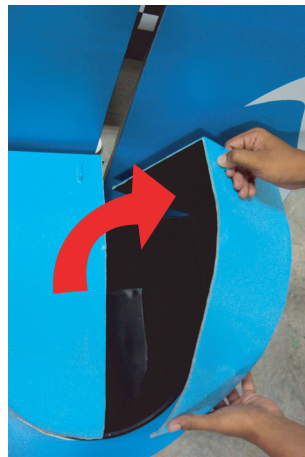

Storage cap can open and close to save property.



Easily to seperate and joint.



HE-PRO (Fly Repellent)

Arnis Aziz

Flies and other insects are pests that could be a nuisance at home and they could cause a turn off to customers in restaurants. These insects breed very fast especially in our tropical climate and could contaminate our food causing food poisoning. Based on the issue, HE-PRO - an ergonomic, green yet user-friendly device- is created. The design is made to be suitable in size, weight and appearance, appropriate to be used in any areas, namely in kitchens, restaurants, stalls or others. The design of HE-PRO is influenced by the duck head because the designer believes that the duck form is attractive to most people. Moreover, by applying yellow and white colours onto the device's body, the design is meant to be fun and attractive to all. This device adopts sustainable sources such as herbs to repel the insects especially flies. Herbs have been proven to be the original and effective household cleaners, disinfectants, and bug repellents since thousands of years before we started turning to chemicals.

The designer embraces the fact that these selected herbs would not only be better for the environment but they could actually improve the environment. For instance, it could be used as compost heap after it had lost its freshness or became dry. Using simple steps, these herbs will be placed into the device container in which the aroma will spread to the surrounding area for repelling the flies using the air-freshener dispensing concept. The best place to fit the device is near the served food since it is safe for both humans and pets. HE-PRO will definitely bring about new meaning in comfort living as it is much safer, cleaner and more tidy as compared to the conventional adhesive paper fly-trap or any toxic repellants. Thus, the product is aesthetically harmonious for instilling a green environment at where it is fitted.

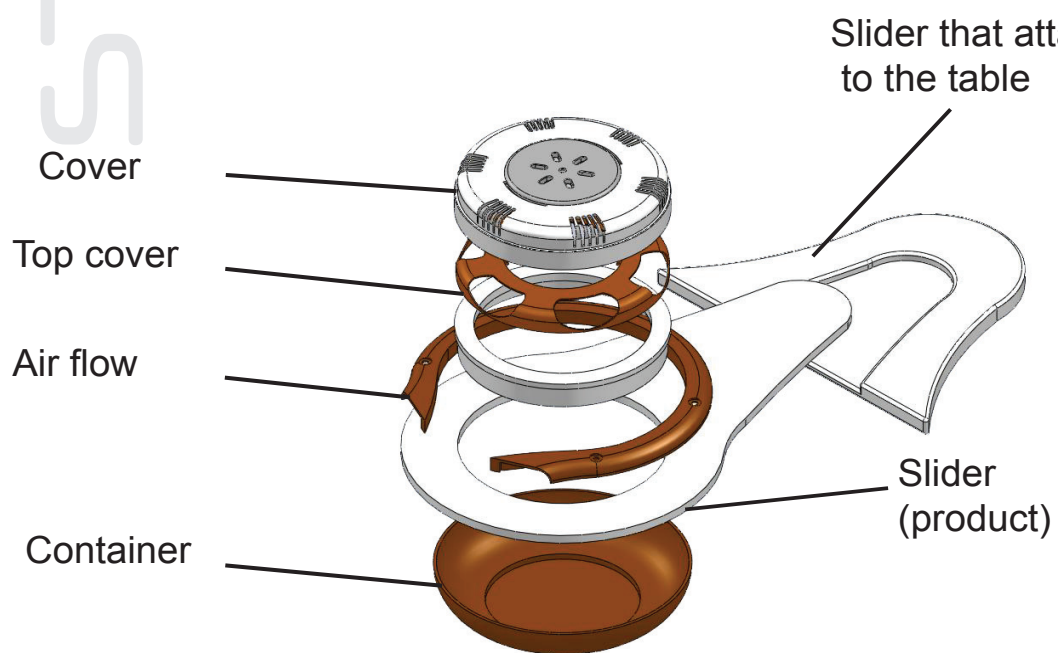

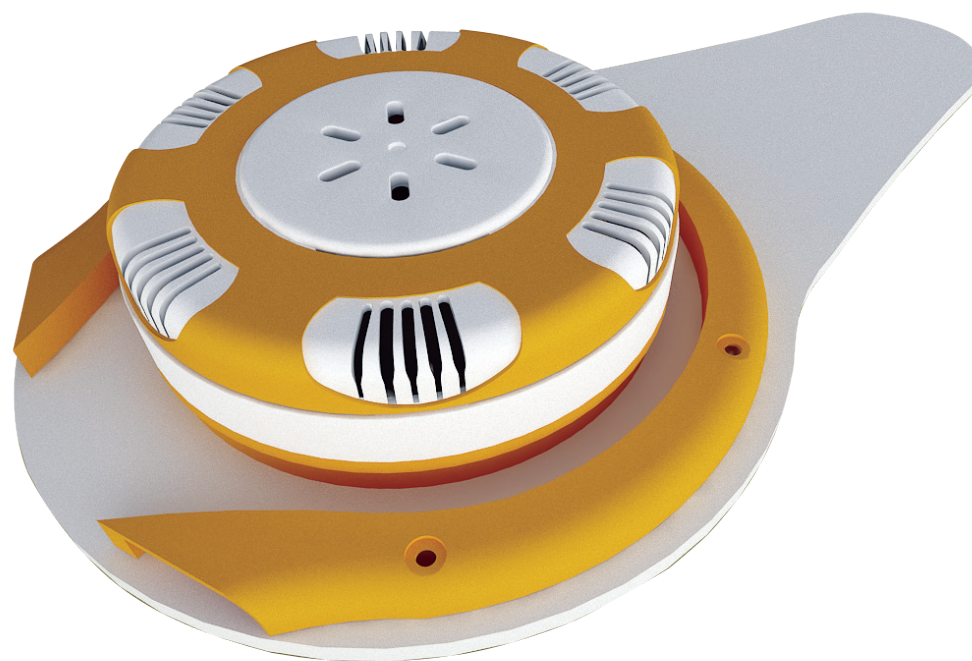
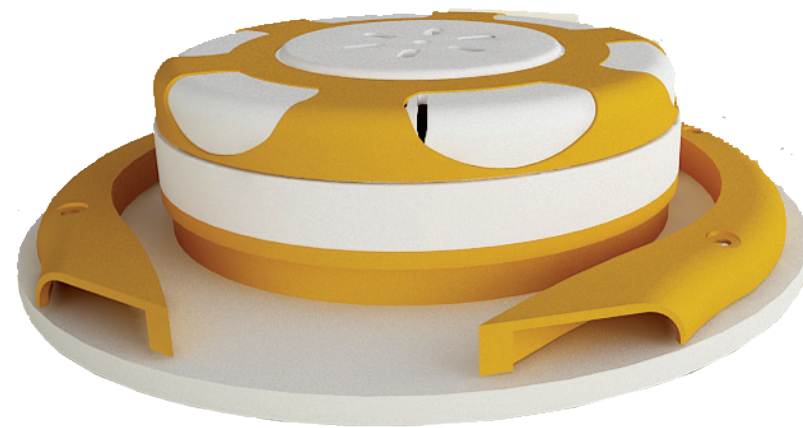

Mohammad Ayatollah Hashim
ID registration:12-00942-0101
Co-inventors: Mohd Faiz Yahaya & Ruhaizin Sulaiman