

AN INVESTIGATION
INTO THE
THERMAL PERFORMANCE OF HOUSING IN THE HOT DRY CLIMATE
OF IRAN

BEHZAD SODAGAR
BSc, MPhil

A thesis submitted in partial fulfilment of the requirements for the
Degree of Doctor of Philosophy at the Building Science Section,
School of Architecture, University of Newcastle upon Tyne.

February 1991

ABSTRACT

This study is concerned with the identification and utilisation of design solutions for improving the thermal environment of residential buildings in hot dry climates in general and the hot arid zone of Iran in particular.

The influence of various energy conservation options on energy use in a prototype house has been analysed using the ESP dynamic computer simulation program. The research was aimed at providing a range of design guidelines for use in the process of building design by builders, architects and engineers. It also suggests programs relying on occupancy behaviour such as; thermostat settings or operating windows.

The recommended design solutions are among those which can be obtained economically through the architectural application of commonly available construction materials and skills whilst also being appropriate in the socio-economic context in which the design and use of buildings take place.

The effect of parameters such as; thermal mass and insulation, surface characteristics, orientation, window design, shading and environmental control strategies on the thermal performance of the prototype house has been investigated. Energy and comfort have been used as indicators of performance.

ACKNOWLEDGEMENTS

I would like to thank my supervisor, Mr. Brian Warren for his valuable and continuous advice and constructive comments during all stages of this work.

I am also grateful to Professor John Wiltshire, the head of the School, for his valuable support and advice which brought this work to completion.

Appreciation is also extended to all members of the School of Architecture and particularly those in the Building Science Section for their generous help and advice. I am greatly indebted to Dr. Steve Dudek, Dr. Andrew Wright, Mr. Steve Lockley and Mr. Norman Harper for their constructive suggestions throughout this study.

Finally I would like to thank my wife, Sima, and my children, Poya and Parisa for their support and love to whom this thesis is dedicated.

TABLE OF CONTENTS

	Page
Abstract	I
Acknowledgements	II
List of tables	VI
List of figures	VII

CHAPTER 1: INTRODUCTION

1.1 Introduction	2
1.2 Research objectives	4
1.3 Building performance determinants	4
1.4 Models of energy determinants	6
1.5 Building energy simulation programs	9
1.6 Design and study tool	9
1.7 Problem statement	9
1.8 House type	12
1.9 Control conditions	14
1.10 Thesis organisation	22
1.11 References	25

CHAPTER 2: CLIMATE AND BUILDING DESIGN IN HOT DRY CLIMATES

2.1 Introduction	28
2.2 Geographical distribution of hot dry climates	28
2.3 Climatological elements affecting planning and building design	31
2.3.1 Solar radiation	34
2.3.2 Air temperature	37
2.3.3 Humidity	38
2.3.4 Precipitation	39
2.3.5 Winds	40
2.4 Weather data generation	41
2.5 Definitions of heating and cooling periods	42
2.6 References	46

CHAPTER 3: BUILDING BIOCLIMATIC ANALYSIS

3.1 Introduction.....	49
3.2 Thermal comfort.....	50
3.2.1 Air temperature.....	52
3.2.2 Mean radiant temperature.....	54
3.2.3 Humidity.....	55
3.2.4 Air motion.....	56
3.2.5 Clothing.....	57
3.2.6 Activity.....	60

3.3	Thermal indices.....	62
3.3.1	Fanger's Comfort Model	64
3.3.1.1	PMV Thermal Index	65
3.3.1.2	PDD Thermal Index	66
3.4	References	67

CHAPTER 4: HEAT FLOW THROUGH THE BUILDING FABRIC

4.1	Introduction	70
4.2	Energy flow across the fabric	70
4.3	The effect of thermal mass and insulation on heat flow through the fabric	72
4.4	The effect of the masonry thickness on the heat flow through walls	96
4.5	The effect of insulation thickness on the heat flow through walls	97
4.6	surface characteristics with respect to radiation ...	99
4.7	The effect on heat flow of colour, orientation and thermal resistance of the fabric	101
4.8	References	109

CHAPTER 5: THE EFFECT OF MASS ON COMFORT AND ENERGY REQUIREMENTS

5.1	Introduction	112
5.2	Development of the computer models	114
5.3	Selected results	116
5.4	Energy related indicators : loads	118
5.5	Environmental indicators : thermal comfort	138
5.6	References	152

CHAPTER 6: THE EFFECT OF ROOF DESIGN ON THE THERMAL PERFORMANCE OF BUILDINGS

6.1	Introduction	154
6.2	Classification of flat roofs with regard to insulation position	155
6.3	The effect of colour and thermal resistance of roofs on their surface temperatures.....	163
6.4	The effect of colour and thermal resistance of roofs on annual heating and cooling loads	165
6.5	Roof shading	169
6.6	Economic considerations	175
6.7	References	180

CHAPTER 7: THE EFFECT OF WINDOW DESIGN ON THE THERMAL PERFORMANCE OF BUILDINGS

7.1	Introduction	183
7.2	Heat transfer and windows	184
7.2.1	Solar position	185

7.2.2	Angle of incidence	186
7.2.3	Thermal properties of glass	190
7.3	Performance analysis of external shading devices	192
7.4	Windows dimensions	205
7.5	Window design and energy requirements	211
7.6	Economic considerations	220
7.7	References	228

CHAPTER 8: CONCLUSIONS

8.1	Summary of findings and recommendations	231
8.1.1	Introduction.....	231
8.1.2	Thermal properties of building structures....	232
8.1.3	Thermal response of buildings.....	236
8.1.4	Roof design.....	239
8.1.5	Window design.....	244
8.2	Limitation and future research areas	246

APPENDIX A	: Choice of the appropriate computer program ...	250
APPENDIX B	: Weather data generation	258
APPENDIX C	: Published papers	275

BIBLIOGRAPHY.....	291
-------------------	-----

LIST OF TABLES

	Page
1.1 Thermostat set points and ventilation rates Continuous Operation	16
1.2 Thermostat set points and ventilation rates Intermittent Operation	17
1.3 Construction details	21
3.1 Values of <i>clo</i> for various clothing ensembles	59
3.2 Metabolic rates of different activities and their mechanical efficiencies	62
4.1 Thermal performance of different test specimens - Summary of results	88
4.2 Variations in internal surface and air temperatures..	91
4.3 Variations in internal surface and air temperatures.. under free-floating conditions.....	92
4.4 Percent reduction in heat flux as the result of insulation thickness	98
5.1 Frequency of excessive temperatures occurring in different zones (Intermittent Operation).....	141
5.2 Frequency of excessive temperatures occurring in different zones (Continuous Operation).....	141
5.3 Comfort analysis : maximum and averaged values of <i>PPD</i> over a week in February (Intermittent Operation).....	151
6.1 Construction details	158
6.2 Reduction in annual loads due to applying insulation.	168
7.1 The effects of window design and orientation on the annual energy requirements of rooms	219
8.1 Maximum surface temperatures of asphalt	240
8.2 The effect of insulation thickness and colour of the roof on annual loads	240
8.3 Reduction in annual loads as a function of insulation thickness	241
8.4 Correction factors for roof surface modifications ...	241
A.1 Candidate simulation programs	253
A.2 Candidate simulation programs	254
B.1 Constant b_{ij} for use with equation B.1	260
B.2 The precipitable water content	261
B.3 Constants <i>f</i> and <i>g</i> for use with equation B.14	267
B.4 Synoptic climatic data	271

LIST OF FIGURES

	Page
1.1 Simple building energy model (version 1)	6
1.2 Building energy model (version 2)	7
1.3 Building energy model (version 3)	7
1.4 Building energy model (final version)	8
1.5 Floor plan of the reference house	13
1.6 The effect of the rate of ventilation air change on cooling loads	20
2.1 World map of climate	29
2.2 The climatic region of Iran	30
2.3 The building as part of a spatial shell-like system .	32
2.4 Air temperature range in the City of Yazd	38
2.5 Relative humidity range in the City of Yazd	39
2.6 Cooling season period	45
2.7 Heating season period	45
3.1 Predicted Percentage of Dissatisfied (<i>PPD</i>) as a function of Predicted Mean Vote (<i>PMV</i>).....	66
4.1 Heat flux at the inside surface of a homogeneous wall	74
4.2 Diagrammatic representation of effect of thermal mass and thermal transmittance on the energy flow through an exterior wall	75
4.3 Thermal performance of the 10mm insulation panel	80
4.4 Thermal performance of the 220mm brick wall	81
4.5 Thermal performance of the 27mm insulation panel	82
4.6 Thermal performance of the externally insulated brick wall	83
4.7 Thermal performance of the internally insulated brick wall	84
4.8 Thermal performance of the cavity brick wall	85
4.9 Heat flux per square metre at the inside surface of walls	87
4.10 Wall temperature rakes	90
4.11 Wall temperature rakes	93
4.12 Wall temperature rakes and inside air temperatures ..	95
4.13 Heat flux per square metre at the inside surface of the externally and internally insulated brick walls .	97
4.14 The effect of orientation on external surface temperatures (July)	102
4.15 The effect of orientation on external surface temperatures (January)	103
4.16 The internal surface temperatures of uninsulated and insulated horizontal concrete slabs (July)	105
4.17 External surface temperatures of insulated and uninsulated south facing brick walls (July)	107
4.18 Internal surface temperatures of insulated and uninsulated south facing brick walls (July)	108

5.1	Construction details of models	117
5.2	Monthly energy requirements of models under continuous operation	119
5.3	Monthly energy requirements of models under intermittent operation	120
5.4	Annual heating requirements of rooms facing different orientations under continuous operation	127
5.5	Annual heating requirements of rooms facing different orientations under intermittent operation	128
5.6	Air temperature in the south facing room	130
5.7	Plant output in the south facing room	131
5.8	Plant output in the north facing room	132
5.9	Air temperature in the north facing room	132
5.10	Annual cooling requirements of rooms facing different orientations under continuous operation	135
5.11	Annual cooling requirements of rooms facing different orientations under intermittent operation	136
5.12	Annual energy requirements of models under different control strategies	137
5.13	Air temperature in the south-east facing room	143
5.14	Air temperature in the south-west facing room	143
5.15	Temperature ranges in rooms facing different orientations	144
5.16	Comfort analysis	146
5.17	Comfort analysis	147
5.18	Comfort analysis	148
5.19	Comfort analysis	149
6.1	Roof types	156
6.2	Ceiling temperatures of the warm and cold roofs	159
6.3	Roof surface temperatures of the warm and cold roofs	160
6.4	Temperature variations in asphalt for the two types of roof	162
6.5	The effect of colour and insulation thickness on the roof surface temperatures	164
6.6	The effect of colour and insulation thickness of the roof on the annual energy requirements of the reference house	166
6.7	Changes in the energy requirements of the reference house due to changing the colour of its roof from dark to light	167
6.8	The effect of roof shading on the roof surface temperatures	172
6.9	The effect of roof shading on the ceiling surface temperatures	173
6.10	Variations in three days cooling requirements of the reference house due to roof shading	174
6.11	Cost analysis for roof design modifications	178
6.12	Annual cost savings and penalties calculated on the base of per square metre of the roof area due to changing the colour of the roof from dark to light	179
7.1	Solar position	185
7.2	Solar chart of the City of Yazd	187
7.3	The angle of incidence	188

7.4	Transmission qualities of 4mm clear float glass	189
7.5	Relative proportion of reflected, absorbed and transmitted radiation for 4mm clear float glass for normal incidence	189
7.6	Horizontal and vertical shadow angles	194
7.7	Shadow angle protractor	196
7.8	Yearly shading chart of the City of Yazd	197
7.9	Overheated period transferred from the yearly shading chart to the solar chart	198
7.10	Shading mask for south facing windows	201
7.11	Shading mask for north facing windows	202
7.12	Shading mask for east facing windows	203
7.13	Shading mask for west facing windows	204
7.14	Design of shading devices using the Olgyay Method ...	206
7.15	Different window arrangements	212
7.16	The effect of window size and shading on the cooling and heating requirements of the north facing room ...	214
7.17	The effect of window size and shading on the cooling and heating requirements of the east facing room	214
7.18	The effect of window size and shading on the cooling and heating requirements of the west facing room	215
7.19	The effect of window size and shading on the cooling and heating requirements of the south facing room ...	215
7.20	The effect of window size and shading on loads	218
7.21	Fenestration cost analysis	221
7.22	The effect of the size of the shading device on the annual cooling and heating requirements of the south facing room	223
7.23	The effect of the size of the shading device on the annual cooling and heating requirements of the east facing room	223
7.24	Fenestration cost analysis for south facing room	224
7.25	Fenestration cost analysis for east facing room	224
7.26	Reference house with new window arrangements	226
7.27	The effect of fenestration design on energy requirements and energy costs	227
8.1	The effect of the thermal heat storage capacity and thermal transmittance on the energy flow through walls	234
A.1	Comparison between the predicted and measured air temperature and relative humidity for a house in Greece in summer	256
B.1	The effect of variations in the level of atmospheric precipitable water content on the amount of radiation received at the earth surface	263
B.2	Direct normal and diffuse horizontal radiation on the 15th of July	268
B.3	Dry-bulb air temperature profiles	272
B.4	Relative humidity profiles	273

Chapter 1

INTRODUCTION

- 1.1 Introduction
- 1.2 Research objectives
- 1.3 Building performance determinants
- 1.4 Models of energy determinants
- 1.5 Building energy simulation programs
- 1.6 Design and study tool
- 1.7 Problem statement
- 1.8 House type
- 1.9 Modelling control conditions
- 1.10 Research organisation
- 1.11 References

1.1 INTRODUCTION

In order to protect himself from the wild, the primitive man sought shelters. His first home was provided by natural features such as caves. As evolution progressed he started realising that in order to flourish he needed more ease and leisure and that an important factor contributing towards this was his ability to control his immediate environment.

In his efforts towards making structures, he soon discovered that different structural combinations have different effects. The success or failure of his experimentation was in many ways determined by one major factor; climate. As the principle of architectural design gradually became understood, so buildings became more complex and the effect of climate on structures became more apparent. The more extreme the climate was, the more influential it became in shaping the built environment.

Many cultures provide outstanding examples of climate-adaptive architecture. An example of this is the compact traditional urban form in hot dry climates. Its compact form makes its exposure to the sun in summer, and the wind in winter minimal. Among its special features are the massive walls to delay the heat gain/loss and small and protected windows to minimise direct solar radiation gains. The surroundings may be appropriately treated to contain grass, trees and water and to avoid any unnecessary paved surfaces thus providing a more agreeable microclimate.

The development of structural engineering during the 20th century dramatically changed the architectural designs which were developed through centuries of practice by the process of trial-and-error. The extensive use of steel and reinforced concrete frames in the erection of modern buildings made it possible for thick load - bearing walls to be replaced by thin curtain walls dominated by vast glazed areas. Moreover, the great demand for housing, especially since World War II, encouraged the development of building industrialisation and prefabrication. The requirements for ease of transportation of building components and units led to the adoption of lightweight construction in many cases.

The success of environmental control technology made it possible to provide comfortable internal environments by the application of increasingly sophisticated HVAC equipment. This freed the architect of this century from pragmatic concerns of comfort and climate and supported the generation of an international, anonymous architecture.

The energy crisis of 1973 provided the incentive for the search for alternative architectural design strategies to overcome the shortcomings of the contemporary energy consuming buildings. This created a new set of circumstances demanding a climate adaptive type of architecture reflecting an attitude toward structures that can employ various conceptual and physical principles of thermodynamics applied to materials and forms as they react to external climate and internal conditions.

Understanding the interactions between buildings' envelopes and the climate have become increasingly important. Many have attempted to express the importance of climate as one of the major parameters in design. Aronin [1] , Olgyay [2 ,3], Givoni [4] and Koeingsberger [5] were among pioneers in the field of climate adaptive building design. More recently, as a result of increased knowledge of the fundamentals of heat transfer, many texts have emerged to discuss the effect of different passive design strategies on comfort levels and energy demands.

1.2 RESEARCH OBJECTIVES

The primary goal of this research is to develop and document appropriate architectural design approaches for residential buildings in the hot arid zone of Iran.

The study does not record in detail the design characteristics and the thermal performance of the indigenous architecture of hot dry lands as they are relatively well documented in the literature. However, those solutions whose effects on the thermal performance of buildings are appreciable and are still applicable in the present socio-economic context are referred to and have been employed.

1.3 Building performance determinants

Thermal performance of buildings may be evaluated by energy related

and/or environmental indicators. The former may consist of;

- *Annual heating requirements*
- *Annual cooling requirements*
- *Annual total energy requirements*
- *Annual heating cost*
- *Annual cooling cost*
- *Annual total cost*

Environmental indicators may be taken as;

- *Thermal comfort*
- *Visual comfort*
- *Acoustic comfort*

Since the energy use as a single index is usually the most straightforward means in evaluating thermal performance of buildings, it is taken as the main determinant in evaluating the effects of different architectural design solutions in this study. However, it must be noted that energy usage as an indicator may cause controversy if both heating and cooling seasons have to be considered. This is because one design solution may result in cooling energy savings while penalties in heating requirements. This is more problematic where the cost of heating and cooling fuels are widely different. Under these circumstances, the energy requirements need to be cast into the cost of purchasing energy to give more realistic indicators. In addition to energy related indicators, indoor thermal comfort conditions have been analysed in assessing the overall thermal performance of buildings throughout this study.

1.4 MODELS OF ENERGY DETERMINANTS

Figure 1.1 illustrates the simplest descriptive model of energy use. As the building, through a series of complex interactions which can either be approximated using simple calculations, or modelled more precisely using advanced computer programs, acts as a filter between climate and energy use, a description of the building is required to assess its energy use.

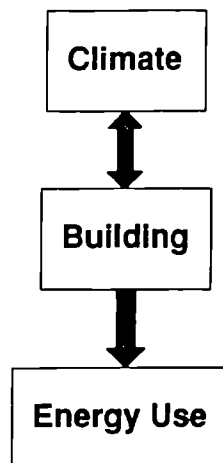

Figure 1.1 Simple building energy model (version 1)

A conceptual model of greater complexity is shown in Figure 1.2. The complexity added here is due to the occupants; the picture is no longer a well - defined physical condition as it involves human activities.

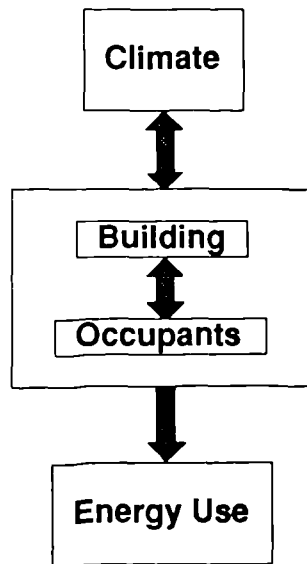

Figure 1.2 Building energy model (version 2)

Buildings represent a process that involves different stages namely design, construction and occupancy. During each of these stages decisions and actions are made that affect building energy use. Figure 1.3 illustrates the conceptual model which shows the dimension of time by including the two stages of design and construction.

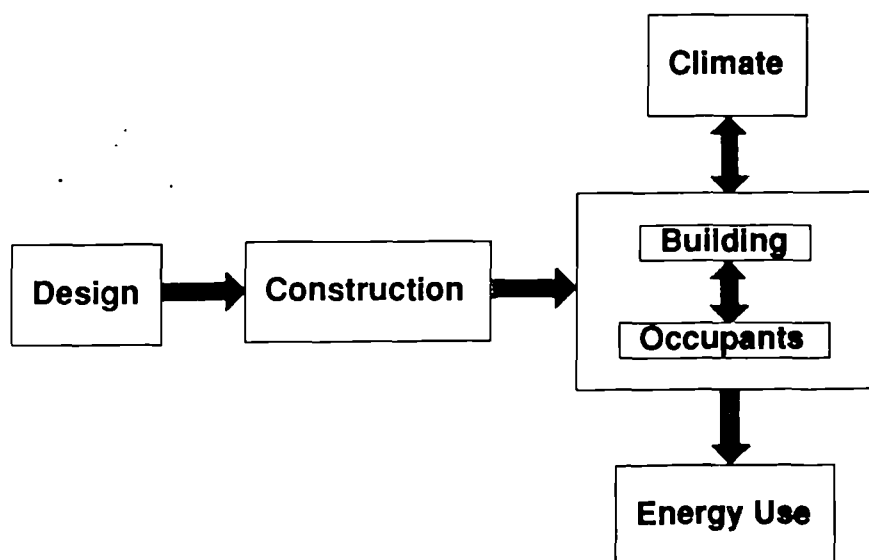

Figure 1.3 Building energy model (version 3)

The design and use of buildings take place in a socio-economic context influenced by countless variables such as ethnic characteristics, cultural norms, building regulations, energy prices, etc. Figure 1.4 acknowledges such a context. This version of the model has been adopted as a framework for this research. The model implies that design solutions should be obtained economically through the architectural application of commonly available construction materials. In addition, the required construction skills and equipment should be consistent with those available for normal construction.

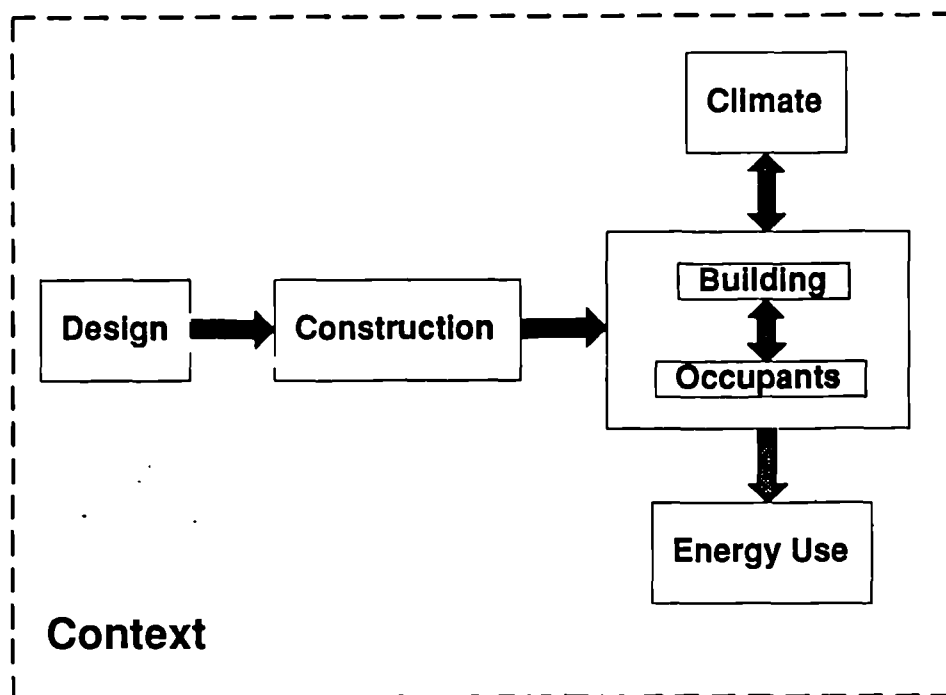

Figure 1.4 Building energy model (final version) adopted as the framework for this research

1.5 BUILDING ENERGY SIMULATION PROGRAMS

The use of building energy simulation programs has proliferated during the last three decades. Until the early 1970s, computer programs were primarily used for sizing HVAC equipment. Pursuant to the oil embargo of 1973, more attention has been devoted to passive and innovative design strategies involving architectural modification of the building fabric to reduce heating and cooling loads and to utilise environmental sources and sinks of energy.

The basic impetus for using advanced simulation programs is inadequacy of traditional simplified approaches, i.e. steady state heat transfer calculations. These procedures, as have been discussed in the forthcoming chapters, seldom can represent the actual situations, i.e. transient thermal behaviour of buildings in response to the transient thermal forces.

1.6 DESIGN AND STUDY TOOL

ESP, a dynamic computer simulation programme, has been used as the design aid for this study. The reasons for this selection are given in Appendix A.

1.7 PROBLEM STATEMENT

The overall thermal performance of a building in the context shown

in figure 1.4 is the result of a complex interaction between several factors, including the climate, the occupants, and thermal characteristics of the building. Changing the thermal performance of any one of the building's parameters will change the overall thermal performance of the building. The thermal effect of a particular combination of building parameters is usually not the simple addition of the effects of the individual parameters of the combination.

The number of possible combinations, K , of any number of parameters, n , can be determined by the following mathematical expression;

$$K = 2^n - 1 \quad (1.1)$$

Where, n denotes the number of parameters to be considered in all possible ways without regard to order. Since n in the expression above appears as an exponent, the number of possible combinations increases rapidly with the number of parameters to be combined.

The number of different cases to be treated can thus become very large, which makes it difficult to reach any systematic conclusions. Consider some key parameters such as; mass, insulation, ventilation, shading, special glass, and night time temperature set back. The number of possible combinations of the above six

parameters is 63. The number of possible combinations becomes dramatically unmanageable when considering different values or options of each parameter. Take the mass as an example, it can be in the external walls, roof, floor, internal partitions or in a set of combinations of two or more of them. If in the external walls, the question may rise if it should be seen from interior or not.

The possible combinations of parameters will be extremely large and obviously unmanageable in studies of this type. It seems worthwhile therefore in order to lessen the great combinatorial burden that it places on the analysis, computer time and cost, to adopt the procedure of taking a central case and addressing only those key parameters which are considered to be practicable and reasonable in the context of the study. In addition, the number of performance assessments can be minimised by not modelling those parameters whose effects have already been studied in sufficient depth and are well documented in the literature.

This would lead to the fact that it is not crucial for example to model the effect of the internal shading devices while external shading devices have proven more satisfactory. By limiting the scope of the study to modelling what is considered to be practical and reasonable, it is not crucial for example to model parameters such as special glazing as they are not usually used in the housing industry in Iran because of the relatively high cost.

1.8 HOUSE TYPE

Many studies have modelled single - zone test buildings which did not contain interior partition walls. This is because even when computer programs are capable of modelling multi - zone buildings, simplifying the geometry of buildings by the removal of interior partitions reduces computing time and cost. The removal of interior partition walls may affect the observed results [6,7]. To assess the thermal performance of buildings more realistically, the basic approach is to divide the building into a number of zones.

Since in Iran one can find different building types, e.g. detached houses, row houses, apartment houses, etc. and for the reasons explained before it is impractical to model all different building prototypes, it is necessary to arrive at a prototype dwelling house which while being representative of a large part of the housing stock, has characteristics capable of revealing useful qualitative information through sensitive analysis.

The prototype depicted in figure 1.5 has been chosen for this study. For a research of this nature which is mainly concerned about the trends and qualitative effects of architectural design solutions on the thermal performance of buildings, the single story nine zone house, hereinafter called the reference house, due to its special zoning, should reveal information of the most general interest, e.g. the effect of different orientations on thermal performance of zones. Simulation runs analysing the effect of different design solutions on the thermal performance of the house should provide a

Figure 1.5 Floor plan of the reference house

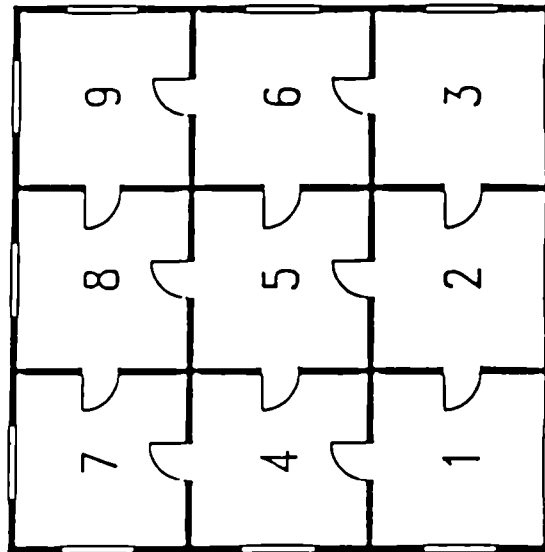

Notes:

Room dimensions: 5.00 x 5.00m
 Floor - ceiling height: 3.00m

Windows: Width: 2.00m
 Sill height: 1.00m
 Head height: 2.50m

Doors: Width: 1.00m
 Height: 2.00m



wide range of design guidelines for bioclimatic housing design, for example, decision making on space allocation, window areas, orientation, etc.

1.9 CONTROL CONDITIONS

In the area of Iran chosen for this study the climate is such that both cooling and heating seasons have to be considered. As has been established in Chapter 2, the heating season effectively consisted of the months from November to March and the cooling season the months from May to September. In order to analyse the effect of design modifications on the energy demands and their ultimate impact on purchasing energy, it is necessary to select a heating and cooling control regime.

As is illustrated in "models of energy determinants" (Figures 1.2 to 1.4), occupants of buildings through their activities, interact with the thermal performance of buildings. To establish this interaction, it is necessary to select occupancy patterns which are considered to be representative of common practice to be defined.

In the cooling season, due to the severity of the climate houses are usually controlled during the hours of the day when most activities take place indoors. In winter, the climate is less severe from the point of view of thermal comfort and consequently there are opportunities for employing intermittent control strategies for space heating.

For optimum thermal comfort in summer conditions of the tropics, CIBSE Guide [8] recommends a resultant temperature of 23 °C. The resultant temperature, t_{res} , for a zone in which the air velocities are kept low to provide a uniform thermal climate, may be obtained from the following equation:

$$t_{res} = 0.5 t_r + 0.5 t_{ai} \quad (1.2)$$

Where:

t_{ai} = inside air temperature, °C

t_r = mean radiant temperature, °C

In the hot arid zone of Iran, having high intensities of solar radiation and high external dry-bulb temperatures, it is likely that the mean radiant temperature of enclosures will be above the controlled inside air temperature in the hot period of the year. For building of various kinds and in widely different climates, surveys during occupation have mean excesses of radiant temperature over air temperature ranging from 0 to 2 °C[8]. By assuming that t_r may become in excess of t_{ai} by 2 °C in summer months, to satisfy thermal comfort, from equation 1.2 we should have:

$$23 = 0.5 (t_{ai} + 2) + 0.5 t_{ai}$$

then;

$$t_{ai} = 22 \text{ °C}$$

This was considered as the thermostat set point for summer conditioning.

In winter, as it is common practice, thermostat points were set so as not to allow the inside air temperature to drop below 20 °C. In intermittent heating, it was assumed that occupants are at work during the day and consequently the plant was switched off between 09 to 15 hours. A temperature set back of 5 °C was also considered in this control strategy between 23 to 05 hours when occupants are in bed. Tables 1.1 and 1.2 give thermostat set points and ventilation rates under different control regimes.

**TABLE 1.1 Thermostat set points and ventilation rates.
CONTINUOUS OPERATION**

(a) : Winter Control Regime

Time (hours)	Controlled Temp. (°C)	Ventilation rate (ac/h)	Occupancy (person/room)
0 - 24	20 minimum	1	2

(b) : Summer Control Regime

Time (hours)	Controlled Temp. (°C)	Ventilation rate (ac/h)	Occupancy (person/room)
0 - 24	22 maximum	1	2

TABLE 1.2 Thermostat set points and ventilation rates.
INTERMITTENT OPERATION

(a) : Winter Control Regime

Time (hours)	Controlled Temp. (°C)	Ventilation rate (ac/h)	Occupancy (person/room)
05 - 09	20 minimum	1	2
09 - 15	system off	1	0
15 - 23	20 minimum	1	2
23 - 05	15 (set back)	1	2

(b) : Summer Control Regime

Time (hours)	Controlled Temp. (°C)	Ventilation rate (ac/h)	Occupancy (person/room)
05 - 23	22 maximum	1	2
23 - 05	system off	20	2

Ventilation and air movement has three distinctly functions:

- 1) - *physiological cooling*
- 2) - *supply of fresh air*
- 3) - *convective cooling*

The first of these; physiological cooling, would be dealt with in Chapter 3 ; *BUILDING BIOCLIMATIC ANALYSIS*.

The requirements of fresh air supply in a domestic situation is usually very small, rarely exceeding a few air changes per hour. For this study a ventilation rate of 1 ac/h, as suggested in CIBSE Guide [8] for living rooms, was considered for health ventilation, i.e. removal of odour, CO₂, etc. when windows are closed. This is the value likely to happen in buildings of normal construction and is taken in many thermal performance assessments as the infiltration rate.

The exchange of indoor air with out-door air can provide cooling, if the latter is at a lower temperature than the indoor air. In hot dry climates, where the ambient temperature is high during the day in summer, and usually above the indoor air temperature, it is therefore advisable to reduce the ventilation rate to the absolute minimum (1ac/h) to meet the requirements of health ventilation, a term usually used for the supply of fresh air.

As would be discussed in the forthcoming chapters of this thesis, in hot dry climates where there exists large diurnal temperature ranges, the exchange of indoor air with cool night time out-door air, a process known as nocturnal ventilation, can provide significant cooling. Passive cooling of buildings by nocturnal ventilation is a common practice in arid zones as it is the simplest and the most economical concept of cooling by natural energies.

The ventilation air change rate (ac/h) of a building is dependent on a number of factors: local wind speeds and directions; the external geometry of the building and its adjacent surroundings; the

window type, size, location, and geometry; and the internal wall partition layout of the building. Each of these factors may have an overriding influence on the ac/h of a given building.

In order to study the benefits of convective cooling during the hot period of the year, the possible ventilation air change rates were estimated by giving information on the relationship between wind vectors (velocity and direction) and the resulting zone surface pressure, together with potential air flow paths in terms of flow type (area, cracks or doorway) to ESPair Submodel. This is the model of the ESP Program which addresses independent air flow studies which are predominantly pressure driven. ESPair simulation results indicated that ventilation of high air change rates, in the order of 50 ac/h, may occur in the reference house when windows and doors are open (openable window area was assumed to be 0.5m^2 and doors were assumed to be partially open; 1m^2). Higher ventilation rates may occur when the openable window area is increased or doors are left fully open.

In performing the studies to determine the benefits of nocturnal ventilation, different ventilation rates (ac/h) were considered during night time hours (23.00 - 5.00) when ambient air temperatures are low and conditions are quiet and stable enough not to cause the problem of dust penetration into buildings (dusty conditions usually occur in the early part of afternoon in the hot arid zone of Iran). Annual cooling loads of the reference house under the intermittent cooling regime (Table 1.2(b)) with different nocturnal ventilation rates were calculated.

The resulting cooling loads have been defined with respect to the non-ventilated reference house. The ratios, CL_x/CL_0 in figure 1.6 compare the annual cooling loads at the given ac/h value (CL_x) to the load at the ac/h value of zero (CL_0). The construction of the reference house modelled was relatively thermally heavy with details given in table 1.3.

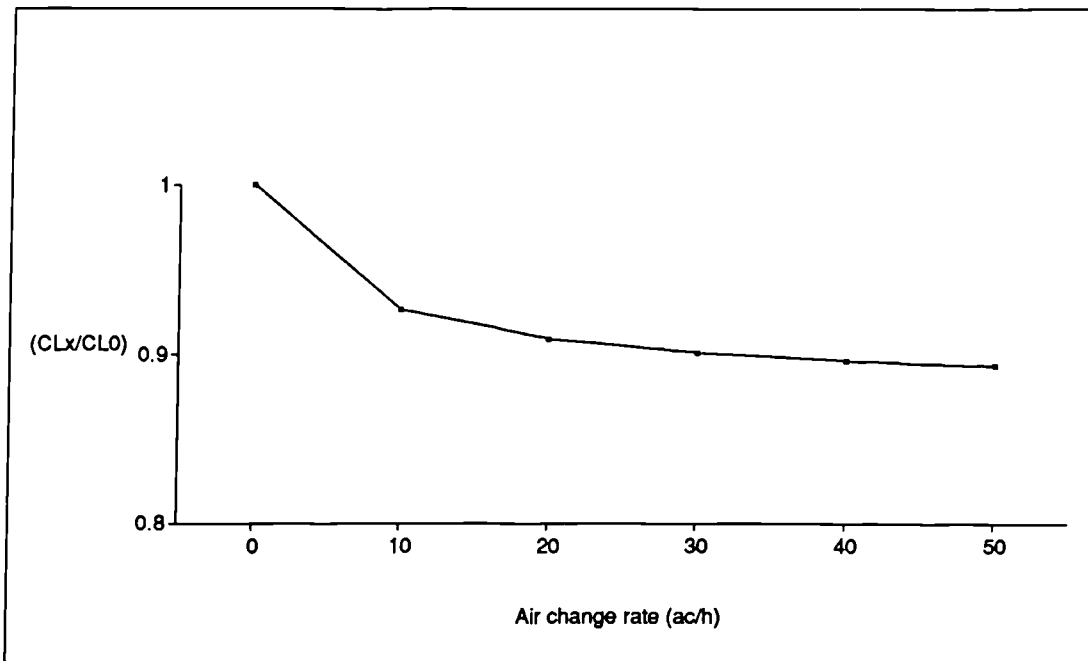

Figure 1.6 The effect of the rate of ventilation air change (ac/h) on cooling loads

Figure 1.6 indicates that there is little benefit in ventilation rates larger than about 20 ac/h regarding reducing the cooling loads. Similar observations have been reported by other researches [10, 11]. It is worth noting that the optimal value of ac/h beyond which the effects of increasing ac/h are practically negligible depends on the thermal storage capacity and level and position of insulation of the building. Fairey et al [10] have demonstrated

that the effects of increasing ac/h practically ceased beyond 20 ac/h for the case of the thermally heavy building they modelled. The corresponding values for thermally lighter buildings, e.g. frame-wood buildings were considerably smaller; a value of the order of about 5 ac/h.

Since there is practically little benefit in ventilation rates larger than 20 ac/h in ventilation cooling of residential building, and since smaller ventilation rates may occur in practice as under typical occupancy pattern not all windows and doors might be left open at one time for the reasons of security, privacy, etc., a rate of 20 ac/h is taken as the fixed nocturnal ventilation rate throughout this study when analysing the effect of passive cooling of buildings.

Table 1.3 Construction details

Roof	20mm asphalt 50mm insulation 75mm screed 150mm concrete slab 25mm plaster
Floor	150mm concrete 150mm hard-core 100mm earth
External walls	220mm brick wall 25mm plastered
Partitions	25mm plaster 105mm brick wall 25mm plaster

The internal gains were specified separately for people and lighting. It was assumed that two people occupy each room during hours of occupancy (Tables 1.1 and 1.2) and add an average of 90 Watts sensible and 50 Watts latent heat per person involving sedentary activities [8]. Lighting was assumed to deliver 8 Watts/m² of the floor area between hours 18.00 to 24.00 assuming tungsten lamps.

The heating and cooling systems are controlled separately for each zone and entirely by air temperature thermostats and are assumed to have sufficient capacity to meet the loads.

1.10 THESIS ORGANISATION

The thesis is divided into 8 chapters and 3 appendices.

Chapter 1 ; *INTRODUCTION*, outlines the objectives and the scope of the research and defines the context in which the research has been carried out. To lessen the great combinatorial burden that the number of possible combinations of parameters places on the analysis, the methodology of the research imposes a strategy whose implementation excludes a large number of parameters which either are not feasible in the context of the study or their effects are well documented.

The interactions between the climate and building design and planning are outlined in Chapter 2 ; *CLIMATE AND BUILDING DESIGN IN*

HOT DRY CLIMATES. This chapter first reviews the climatological elements affecting planning and design of buildings. A weather file was generated using the climatic data of the city of Yazd located in the hot arid zone of Iran to drive ESP simulations. The length of the heating and cooling seasons has been established during which the predicted energy use of buildings would be used as the determinant in evaluating design approaches.

Chapter 3; *BUILDING BIOCLIMATIC ANALYSIS*, examines factors affecting thermal comfort of the occupants. The widely used Fanger Comfort Model which is supported by ESP is used in this research for thermal comfort analysis.

The study of the effects of the thermal characteristics of structures on regulating heat flows through them is the objective of Chapter 4; *HEAT FLOW THROUGH THE BUILDING FABRIC*. The effects of parameters such as thermal transmittance, thermal capacity, the position of insulation and surface characteristics of building elements on the heat flow through them are investigated.

In Chapter 5; *THE EFFECT OF MASS ON COMFORT AND ENERGY REQUIREMENTS*, three different thermal capacity situations were modelled, namely; thermally heavy, medium and light. The design characteristics of the reference house due to its special zoning strategy led the effects of different orientations on loads and comfort to be analysed.

High intensities of solar radiation together with large diurnal

variations in air temperature makes the design of roofs crucial under the climatic conditions of arid zones. Chapter 6; *THE EFFECT OF ROOF DESIGN ON THE THERMAL PERFORMANCE OF BUILDINGS*, investigates the effect of roof design on energy requirements and their ultimate impact on purchasing energy.

The choice of fenestration for a building can significantly affect its thermal performance. The energy performance dependence of the reference house on its fenestration design is analysed in Chapter 7; *THE EFFECT OF WINDOW DESIGN ON THE THERMAL PERFORMANCE OF BUILDINGS*. The accuracy of simple graphical methods, e.g. the Olgyay method, for estimating the size of fixed external shading devices is also investigated.

The last chapter of the thesis, Chapter 8; *CONCLUSIONS*, summarises the results of this research and outlines further work required beyond this stage.

Appendix A; *CHOICE OF THE APPROPRIATE COMPUTER PROGRAM*, first concludes that transient methods which are capable of handling transient multimode heat transfer problems should be sought to satisfy the objectives of this research. The reasons for selecting ESP, a dynamic computer simulation program, as the design aid for this study are also given.

Appendix B; *WEATHER DATA GENERATION*, details the procedures used for simulating hourly values of the climatic variables required to drive ESP simulations.

On the bases of the results obtained in Chapter 5; *THE EFFECT OF MASS ON COMFORT AND ENERGY REQUIREMENTS* and Chapter 7; *THE EFFECT OF WINDOW DESIGN ON THE THERMAL PERFORMANCE OF BUILDINGS* two papers were emerged and formed parts of proceedings of two international conferences [13 & 14]. Appendix C contains the published papers.

1.11 REFERENCES

- [1] Aronin, J. *Climate and architecture*. Reinhold Corp. New York, 1953.
- [2] Olgyay, A. and Olgyay, V. *Solar control and shading devices*. Princeton University Press, 1957.
- [3] Olgyay, V. *Design with climate*. Princeton University Press, 1963.
- [4] Givoni, B. *Man, climate and architecture*. Elsevier Publishing Company, 1969.
- [5] Koenigsberger, O. H. et al. *Manual of tropical housing and building, Part one; Climatic design*. Longman, 1973.
- [6] Dougall, R. S. and Goldthwait, R. G. *Effects of interior partitions and thermal mass in modelling small homes with an hour-by-hour computer program*. American Society of Mechanical Engineers, 1977.
- [7] Rudoy, W. and Dougall, R. S. *Effect of the thermal mass on heating and cooling load in residences*. ASHRAE Conference, Philadelphia, 1979.
- [8] CIBSE GUIDE, Volume A, The Chartered Institution of Building Services Engineers, 1986.
- [9] Givoni, B. *Options and applications of passive cooling*. Energy and Building, 7, 1984.
- [10] Fairey, P.W., Kerestecioglu, A.A. and Chandra, S. *Ventilative cooling in southern residences: A parametric analysis*. Proceedings of the ASHRAE/DOE/BTECC Conference on the Thermal Performance of the Exterior Envelopes of Buildings III, December 1985, Florida, U.S.A.
- [11] Kammerud, R. et al *Ventilation cooling of residential building*. ASHRAE Transactions, Vol. 90, Part 1B, 1984.

[12] Chandra, S., Fairey, P. and Houston, M. *A handbook for designing ventilated buildings*. Department of Energy, Final report (FSEC-CR-93-83), 1983.

[13] Sodagar, B. and Warren, B. F. *The effect of mass on comfort and energy requirements*. Proceedings of the XIth CIB International Congress on the Quality for Building Users Throughout the World, User Comfort, Paris, June 1989.

[14] Sodagar, B. and Warren, B. F. *Window design in hot dry climates*. Proceedings of CIB International Symposium on Energy, Moisture and Climate in Buildings, Rotterdam, September 1990.

Chapter 2

CLIMATE AND BUILDING DESIGN IN HOT DRY CLIMATES

- 2.1 Introduction
- 2.2 Geographical distribution of hot dry climates
- 2.3 Climatological elements affecting planning and building design
 - 2.3.1 Solar radiation
 - 2.3.2 Air temperature
 - 2.3.3 Humidity
 - 2.3.4 Precipitation
 - 2.3.5 Winds
- 2.4 Weather data generation
- 2.5 Definitions of heating and cooling periods
- 2.6 References

2.1 INTRODUCTION

Climate is a primary determinant (clearly not the only one) influencing the design, thermal behaviour and energy economy of buildings. The influence of climate on building design is strong enough to create different specific features of building design and of structural elements in different climates. In a broader perspective, climate affects the pattern of land use, urban design, etc.

This chapter examines the main climatic features which affect the thermal regime of buildings.

2.2 GEOGRAPHICAL DISTRIBUTION OF HOT DRY CLIMATES

Geographically hot dry regions can be found in two belts at latitudes between approximately 15 and 35 degrees north and south. Hot dry lands comprise about a third of all the countries in the world [1]. Arid zones can be found in north Africa, central and western Asia, in the west of North and South America, and in central and western Australia as depicted in figure 2.1.

Iran in south west Asia, located between the Caspian Sea and the Persian Gulf, between 25 and 39 degrees north latitudes, covers an area of 1,648,195 square kilometres. Several climatic classifications of Iran have been provided by several authors [2,3,4]. Figure 2.2 shows the climatic map of Iran based on

Figure 2.1 World map of climate [1]

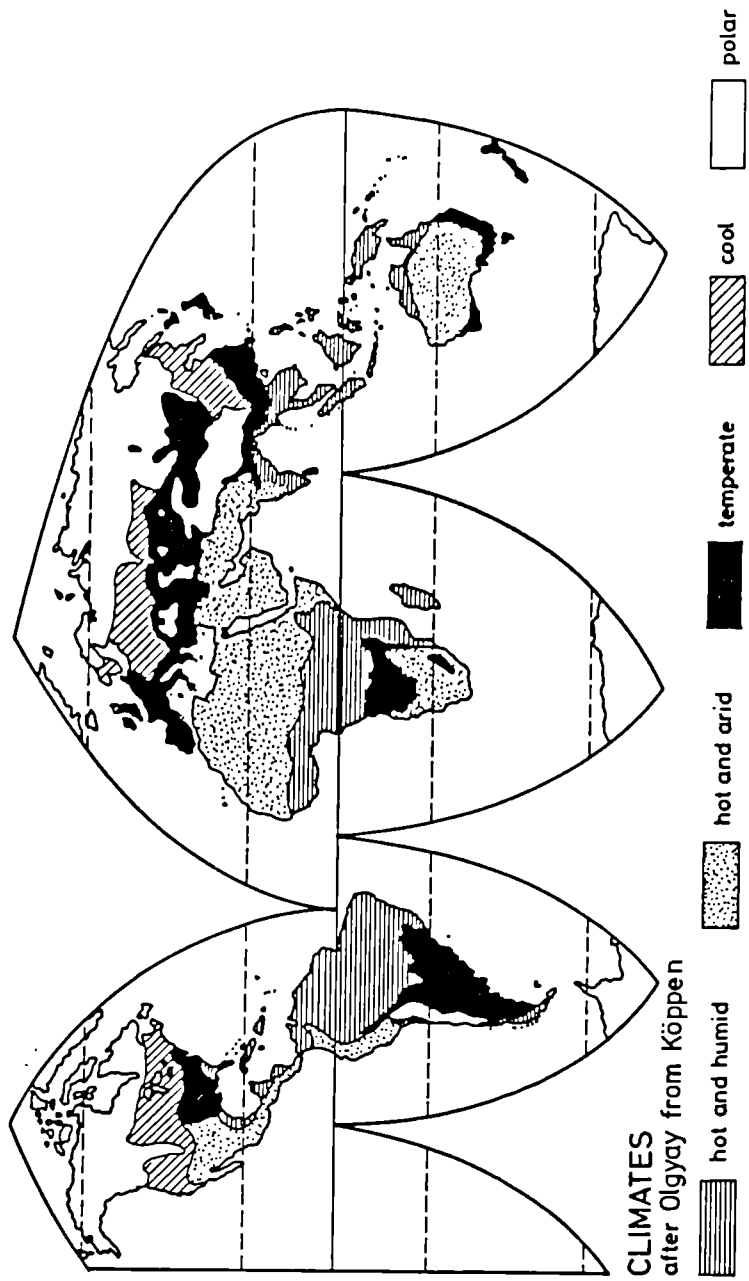
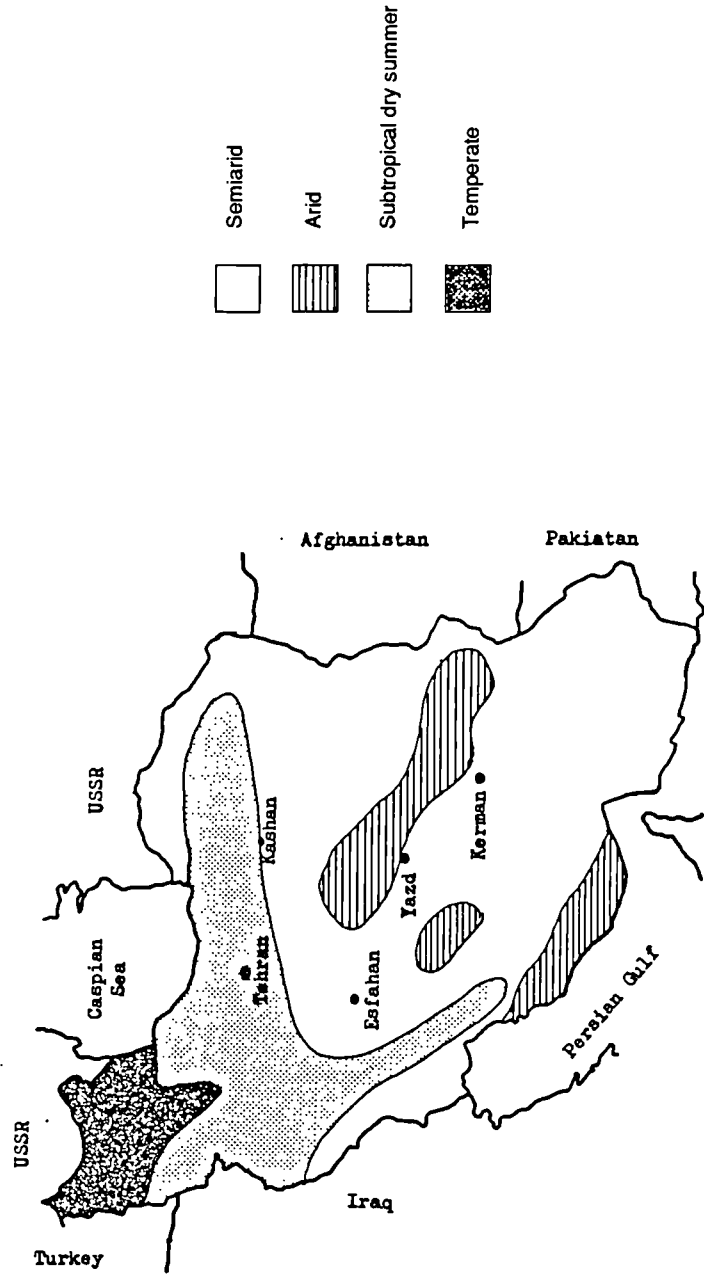

Figure 2.2 The climatic regions of Iran [3]



Tavassoli's classification [3]. Hot dry regions of Iran are generally characterised by having slight precipitation, low humidity, high temperature in the summer and moderate to low temperature in the winter.

2.3 CLIMATOLOGICAL ELEMENTS AFFECTING PLANNING AND DESIGN OF BUILDINGS

Building climatological studies are concerned with an interactive situation, involving both the influence of the weather on the building and the influence of the building on the weather in the space round the building [5]. van Hardenberg [6] has hypothetically shown this as a shell system depicted in figure 2.3.

The climatological parameters which generally have the main impact on planning and design of buildings are the followings;

- 1 - *Solar radiation*
- 2 - *Air temperature*
- 3 - *Humidity*
- 4 - *Precipitation*
- 5 - *Winds*

Additional environmental factors such as; topography, large waterscape, vegetation, etc. must be examined in detail as they can affect the microclimate of a site considerably.

In hot dry climates, it is highly important to take advantage of landscape architecture to modify the harsh climate. Trees, shrubs,

Figure 2.3 The building as part of a spacial shell - like system [6]

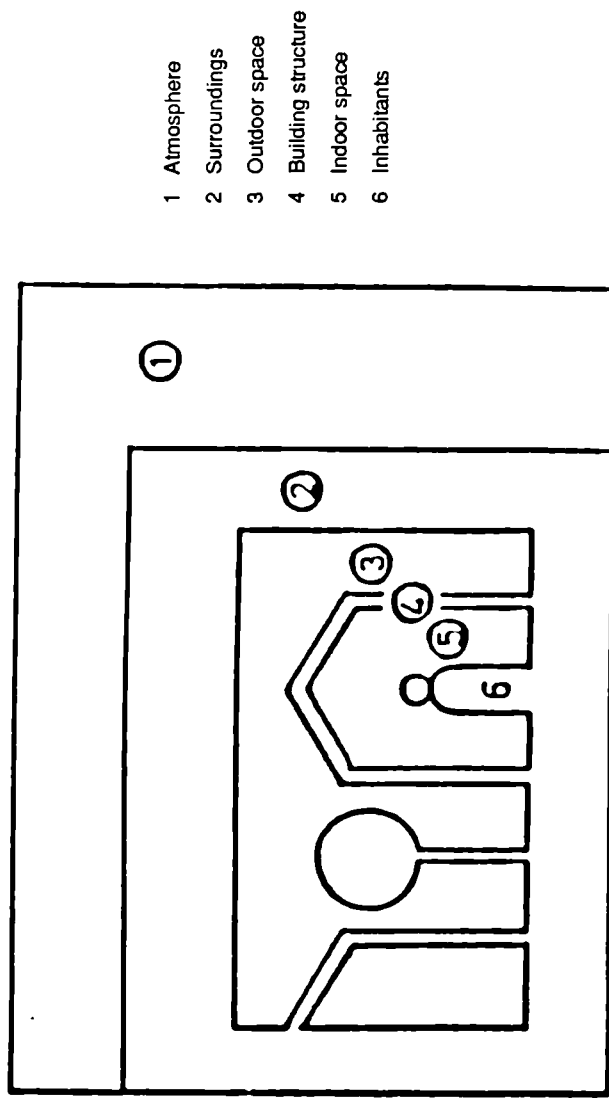

lawns and all green spaces provide significant values to city environment [7]. Bernatzky [8] reports that a small green area in Frankfurt lowered the air temperature by 3-3.5 °C and intensified the relative humidity by 5-10%. The same result has been reported in Sudan by Danby [9]. The micro-climate of the residential areas of Khartoum where the houses are in relatively large areas of well-established gardens, has been found to be two to three degrees cooler than other residential areas where gardens are almost non-existent.

The man-made built environment also affects the climate as significant differences may be found between urban areas and country side, the phenomenon known as heat islands. Koenigsberger [10] has pointed out some of the factors causing deviations of the urban climate from the regional macroclimate as follows;

CHANGED SURFACE QUALITIES (pavements and buildings) - increased absorbance of solar radiation; reduced evaporation.

BUILDINGS - casting a shadow and acting as barriers to winds, but also channelling winds possibly with localised increase in velocity or by storing absorbed heat in their mass and slowly releasing it at night.

ENERGY SEEPAGE - through walls and ventilation of heated buildings, the output of refrigeration plants and air conditioning, heat output of internal combustion engines and electrical appliances, heat loss from industry, especially furnaces and large factories.

ATMOSPHERIC POLLUTION - waste products of boilers and domestic and industrial chimney, exhaust from motor-cars; fumes and vapours, which tend to reduce direct solar radiation but increase the diffuse radiation and provide a barrier to out-going radiation.

2.3.1 SOLAR RADIATION

Over 99% of all energy in the earth's atmosphere has its origin in radiation from the sun [11]. The remaining 1% is supplied by either volcanic eruptions, the radioactive decay of earth minerals, or by burning of organic materials.

The unequal distribution of solar radiation over the earth is the primary cause of weather and climate [12]. The amount of solar radiation received by the earth, assuming there is no interference from the atmosphere, is affected by four factors; solar output, the sun-earth distance, altitude of the sun, and day length [13].

Variation in solar output is small. The solar constant, the energy received at the top of the atmosphere on a surface normal to the solar beam for mean solar distance, a value of about 1370W/m^2 , undergoes small periodic variations smaller than 0.5% perhaps related to sun spots activity.

The amount of solar radiation received by the earth varies through the course of the year owing to the eccentricity of the earth's orbit round the sun. The solar constant is subject to a seasonal variation of about $+ 3.5\text{ W/m}^2$ [14], being highest in early January when the distance of the earth from the sun is minimum (about 147.1 million Kilometres) and lowest in early July when the distance is maximum (about 152.1 million kilometres).

The greater the sun's altitude, the greater is the radiation

received per unit area at the earth's surface. This is mainly due to three facts. Firstly, radiation received from the sun at a high altitude is more concentrated than that received from the sun of a low position as it spreads over a smaller area. Secondly, rays coming from the sun in a high position above the horizon are less scattered by atmospheric particles as they traverse a relatively shorter passage. Thirdly, since the albedo, the reflected portion of insolation at the earth's surface increases as the angle of incidence of the sun's rays increases, a smaller portion of radiation is absorbed at the earth's surface when sun's rays are coming from the sun at a low altitude. (This phenomenon is explained in more detail in Chapter 7)

The length of daylight also affects the amount of radiation that is received. Because of the angle of 66.5 degrees between the axis of rotation and the plane of the earth's orbit around the sun, summer days enjoy longer periods of solar radiation than winter days. The differences between summer and winter days increases with the latitude.

Global yearly radiation in the hot arid zone of Iran is high. The sky is mostly clear during the year and many successive sunny days with repetitive weather conditions are normal to occur. High level of solar energy radiation offers good potential for passive solar heating in the hot arid zone of Iran [15,16,17].

The absorbed ratio of solar radiation by the external surface of opaque building elements, combined with the effect of the outdoor

air temperature, may produce high external surface temperatures resulting in marked heat flows through them. The concept of the sol-air temperature is usually used to indicate the combined effect of radiation and air temperature on buildings' envelopes. Sol-air temperature is that temperature of the outdoor air which, in the absence of all radiation exchanges, would give the same rate of heat entry into the surface as would exist with the actual combination of incident solar radiation, radiant energy exchange with the sky and outdoor surroundings, and convective heat exchange with the outdoor air [18].

The external surface temperatures may fall below that of the outdoor air temperature at nights due to the emitted heat by longwave radiation to the clear skies. The use of the cold sky as a heat sink for the process termed nocturnal radiative cooling, could provide a great potential for reducing the energy demands of conventional cooling techniques and/or an alternative to them.

In summer, the portion of solar radiation which penetrates through windows can significantly increase the indoor air temperature and consequently affect the thermal comfort of the occupants and/or energy demands of buildings. This necessitates careful design of opening and shading devices.

2.3.2 AIR TEMPERATURE

The mean daily temperature cycle reflects the balance between incoming solar radiation and outgoing radiation, known as terrestrial radiation. The radiation emitted from the earth's surface is longwave radiation, in contrast to the predominating shortwave radiation it receives from the sun. While the atmosphere absorbs only about 25% of the incoming solar radiation, it is highly absorbent to infra-red radiation (some 84% of this radiation is absorbed) [10], as many atmospheric trace gases such as water vapour, carbon dioxide, ozone, etc. absorb some of the infra-red radiation emitted from the earth surface. In this respect the atmosphere acts somewhat like glass, letting through much of the incoming solar radiation but absorbing most of the outgoing longwave radiation, a phenomenon referred to as the "greenhouse" effect.

When cloudy conditions prevail, a balance is soon reached between terrestrial radiation and re-radiation from the lower atmosphere downwards and temperatures will remain unchanged. On the other hand, under clear sky conditions, the terrestrial radiation heats a much thicker layer of the atmosphere and outgoing earth radiation is maintained by the temperature differences between the earth's surface and the lower atmosphere.

The atmospheric conditions of hot dry climates which produce a higher degree of solar radiation reaching the ground by day, lead to rapid cooling at night by effective terrestrial radiation through clear skies causing a large diurnal temperature range (figure 2.4).

In winter, clear skies at nights may produce cold nights having temperatures below freezing point.

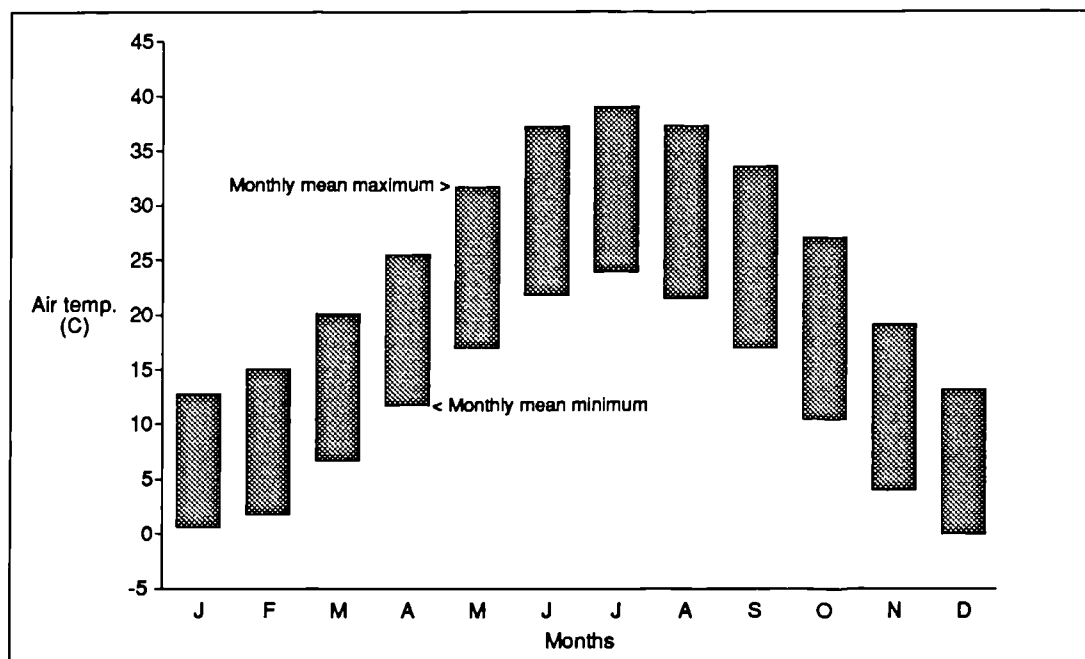

Figure 2.4 Air temperature range in the City of Yazd

2.3.3 HUMIDITY

In hot dry climates, as the name implies, the humidity of the air is normally low. The relative humidity, which is most often used to express the water vapour condition of the air, is low in summer and moderate in winter (figure 2.5).

Since the human body may be cooled naturally by the evaporation of perspiration, a process which is facilitated by low relative humidity levels, hot dry conditions are often more comfortable than

extremely hot humid weather. However, excessive dryness of the air may cause unpleasantness due to the dryness of lips and mucous membranes of the upper respiratory tract.

The low relative humidity of hot dry climates facilitates the potential of cooling by evaporation. Evaporative cooling could bring high temperatures down to thermally acceptable levels.

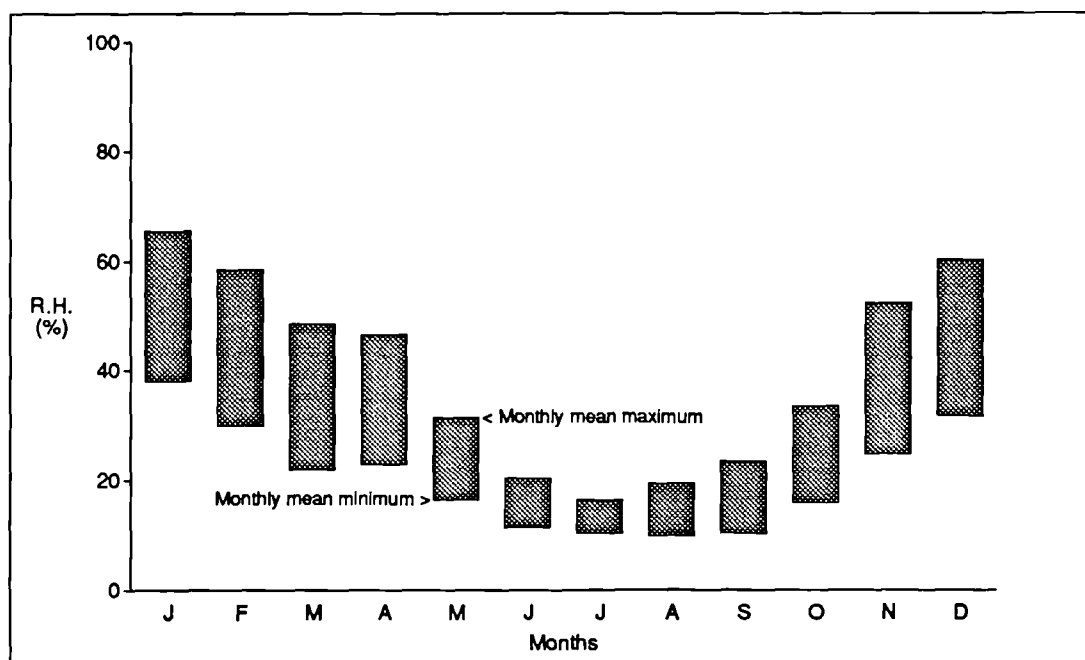

Figure 2.5 Relative humidity range in the City of Yazd

2.3.4 PRECIPITATION

It is normal that during the hot spell of the year, the hot arid lands do not receive any precipitation for a few months. In the cold period of the year, short intervals of rain or snow are

experienced followed by sunny days. Hot arid zones of Iran receive on average less than 300mm of precipitation per year [3].

2.3.5 WINDS

The manifestation of air flow can be divided into two groups; the global wind patterns and the local wind patterns [19]. While the former has its origin in the differential radiation balance on the earth's surface varying with latitude and rotation of the earth, the latter is due to the daily variations in heating and cooling of land and sea and topography of the given region and its surrounding.

Wind together with other climatic variables affects the external surface temperatures of building elements. During quiet and stable conditions, natural convection currents may take place at the external surfaces. When these convection currents are associated with wind, the process of heat gain or loss becomes quicker and more effective depending on the spatial relation of the surface and wind currents.

The direct effects of wind on the indoor climate are even more significant by affecting the number of air exchanges between the building and ambient, i.e. the ventilation/infiltration rates. The outdoor air enters the building at its original condition of humidity and temperature producing a very rapid effect on internal conditions.

Air entering a building can be due to:

- 1 - *infiltration through cracks around windows, doors, etc.*
- 2 - *air flow through ventilation openings*

The former may be called "adventitious air flow" which is mainly due to the air permeability condition of the structure, the latter which may be termed as "user defined air flow" occurs as a result of deliberate action on the part of the occupants of the building, e.g. by opening windows.

Both "adventitious" and "user defined" air flows may take place by wind flow and/or variation between the internal air temperature and external temperature producing what is termed "stack effect". The "stack effect" relying on thermal forces, will rarely be sufficient to create appreciable air movements [10]. Givoni [20] has shown that high air velocities (up to 152% of external wind speed) may occur in cross-ventilated rooms depending on wind direction with regard to size and position of openings.

2.4 WEATHER DATA GENERATION

The climatic variables required by ESP to drive simulations are hourly values of:

- *dry bulb temperature (Deg. C)*
- *direct normal radiation intensity (W/m^2)*
- *diffuse horizontal radiation intensity (W/m^2)*
- *wind speed (m/s)*
- *wind direction (degrees from north)*
- *relative humidity (%)*

There are many cities, particularly in developing countries, for which hourly values of climatic variables are not available. For these localities, solar values - as required by the energy modelling systems- are almost missing due to the cost and technical difficulties in measuring solar radiation intensities.

In the absence of hourly measured climatic variables from Iran, prediction routines were employed to obtain hourly values by using the available climatic data for the City of Yazd located in the hot arid zone of Iran whose geographical location is shown on figure 2.2. Appendix B details the procedures used for simulating hourly values of the climatic variables required to drive ESP simulations.

2.5 DEFINITIONS OF HEATING AND COOLING SEASONS' PERIODS

The climate of Yazd has two distinct periods; a heating season and a cooling season. For the sensitive simulation studies it is necessary therefore to define the length of the heating and cooling periods. Preliminary simulations were performed for buildings having a range of thermal properties to establish times of year when either heating or cooling is required. On the basis of the results of the preliminary simulation runs and the author's knowledge of the times when the local people start heating or cooling their buildings, it was determined that the heating season should be considered to consist of 5 months, from November to March. The cooling season is also considered to consist of 5 months, from May to September. During two months of the year, April and October, the weather is

such that there is usually no need for active heating or cooling of buildings.

Interestingly enough, the results of the above definition compare well with the climatic analysis method developed by Bitan [21 and 22]. Bitan performed a comprehensive topo-climatological research whose aim was to provide the climatic information to serve the planners and architects in developing settlements in the hot dry climate of the Jordan Valley located in the same belt of latitude as the site chosen for this study. The intention of the research was not only to provide data on various climatic parameters but also to advise architects and planners how to use these data and incorporate them in improving the built environment at all levels - from locating the settlements to their detailed design, e.g. style of building, need for cooling, heating, etc.

Bitan observes if the arithmetic mean of the dry-bulb and wet-bulb temperature, K , i.e.:

$$k = \frac{\text{dry-bulb} + \text{wet-bulb}}{2} \quad (2.1)$$

is lower than 22 units the climate for human being is comfortable and no heat stress would be experienced. If; $22 < k < 23.9$ there is light discomfort (light heat stress), and if; $24 < K < 27.9$ there is moderate discomfort (medium heat stress) and if ; $K > 28$ units there is heavy discomfort (heavy heat stress).

Results of calculating the various levels of heat stress for the City of Yazd are shown in Figure 2.6. The results are based on the simulated hourly values of the dry-bulb temperatures of the representative days for different months (see Appendix B). Hourly values of wet-bulb temperature for calculation of K were obtained by the interpolation between the dry-bulb temperature and the relative humidity of air using the CIBSE Tables [23] containing the thermodynamic properties of the air.

Figure 2.6 shows that Yazd suffers from heat stress for 5 months, from May to September. During this period cooling may be required to prevent heat discomfort.

As discussed previously, due to large diurnal temperature variations in arid zones, there is not one month at Yazd when heat stress persists for 24 hours continuously. Only in July the heavy heat stress persists for a period of several hours each day. Figure 2.6 highlights that heat stress persists for a quite considerable length of time during days in the cooling season.

According to Bitan's method heating may be required if the sum of all heating degree-days to a base temperature of 18.3°C in a month is 75 or over. For a day when the mean daily temperature is 1°C below the base temperature, such a day gives "1 degree-day". A day with a 2°C drop below base (or two days with a 1°C drop) will give 2 degree-days and so on.

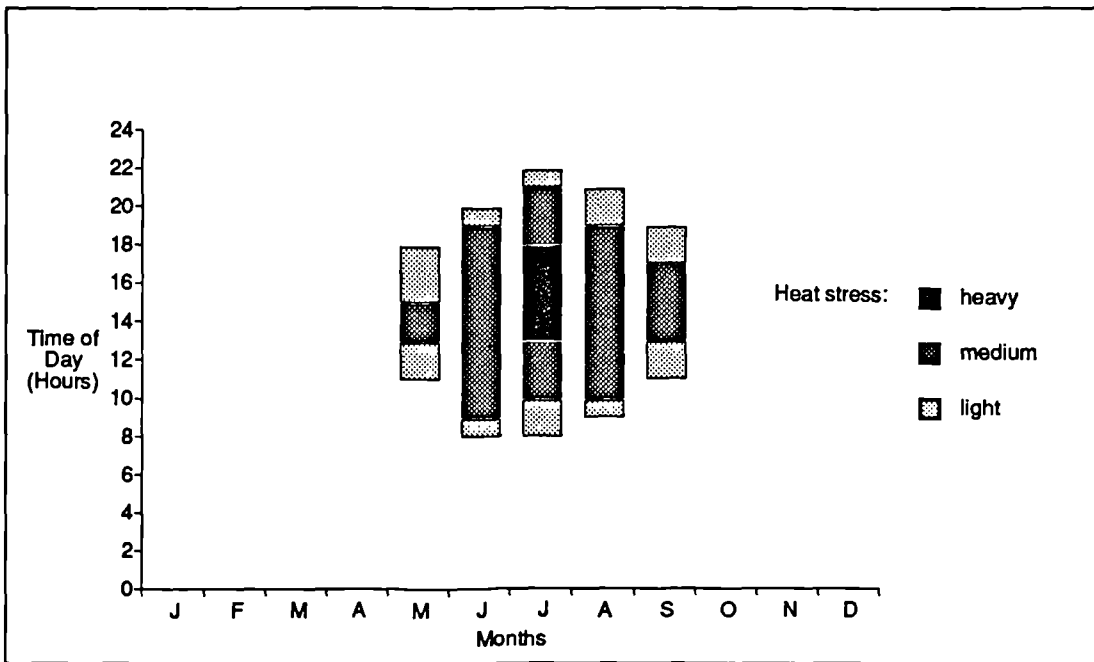

Figure 2.6 Cooling season period
 Months in which the arithmetic mean of the dry-bulb and wet-bulb temperature is greater than 22 °C are considered as candidates for cooling season period (May to September). The figure also shows the severity of the heat stress in each month

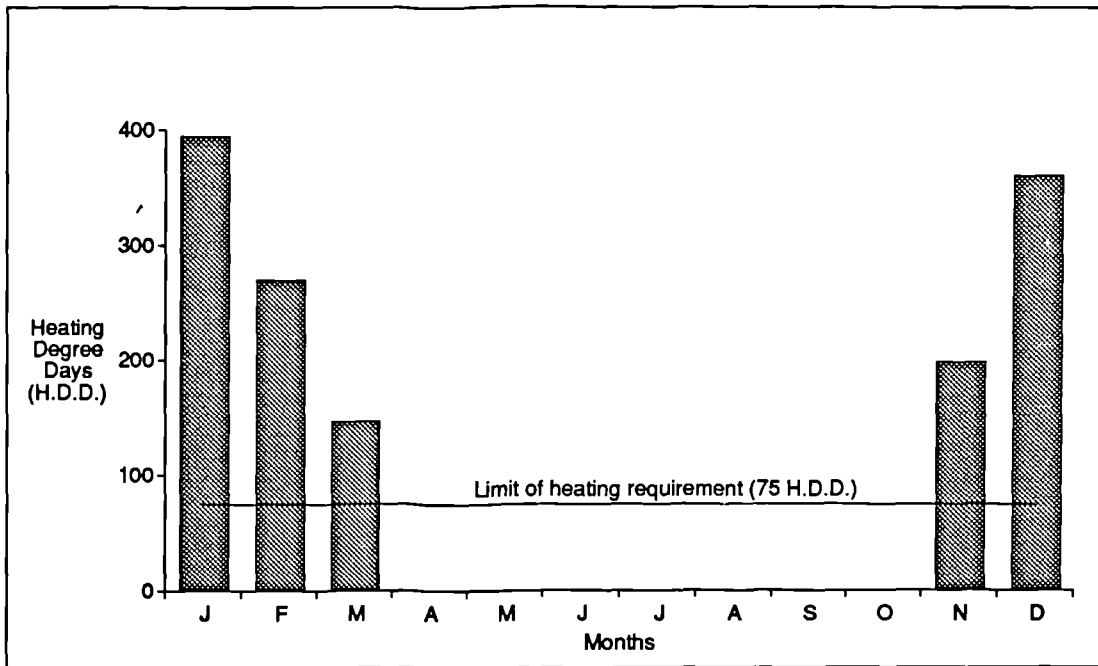

Figure 2.7 Heating season period.
 Heating may be required if the monthly heating degree days to a base temperature of 18.3 °C is over 75

Monthly heating degree-days for the city of Yazd are shown in figure 2.7. The number of degree-days in each month is calculated by multiplying the difference between the mean daily temperature of the representative day in each month and the base temperature by the number of days in that month. For example the number of degree-days in January is:

$$(18.3 - 5.5) * 31 = 396.8$$

Figure 2.7 indicates that during 5 months, from November to March, the climate of the City of Yazd is so that heating may be required.

2.6 REFERENCES

- [1] Saini, B.S. *Building in hot dry climates*. Jhon Wiley and Sons, 1980.
- [2] Adle, A.H. *Climate and vegetation in Iran*. University of Tehran, 1960. (in Farsi)
- [3] Tavassoli, M. *Urban structure and architecture in the hot arid zone of Iran*. University of Tehran, 1979. (in Farsi)
- [4] Riazi, J. *Climate and comfort*. Ministry of Housing and Urban Design, Centre for Research on Housing and Building, Tehran, 1977. (in Farsi)
- [5] Page, J.K. *Application of building climatology to the problems of housing and building for human settlements*. Technical note No. 150, World Meteorological Organisation (WMO), 1976.
- [6] van Hardenberg, J.G. *Considerations of houses adapted to local climate. A case study of Iranian houses in Yazd and Esfahan*. Energy and Buildings, Vol.4, 1982.
- [7] Enis, R. *Landscape and climate - the interdependence of some of their factors*. Energy and Buildings, Vol.7, 1984.

- [8] Bernatzky, A. *The contribution of trees and green spaces to a town climate.* Energy and Buildings, Vol.5, 1982.
- [9] Danby, M. *The design of buildings in hot dry climates and the internal environment.* Built International, 6, 1973.
- [10] Koenigsberger, O.H. et al *Manual of tropical housing and building, Part one: climatic design.* Longman, 1973.
- [11] Nieuwolt, S. *Tropical climatology, an introduction to the climates of the low latitudes.* John Wiley and Sons, 1977.
- [12] Trewartha, G.T. and Horn, L.H. *An introduction to climate.* McGraw-Hill Book Company, 1980.
- [13] Barry, R.G. and Chorley, R.J. *Atmosphere, weather, and climate.* Methuen, 1987.
- [14] CIBSE GUIDE, Volume A, Section A2; Weather and solar data. The Chartered Institution of Building Services Engineers, 1986.
- [15] Bahadori, M. N. *A feasibility study of solar heating Iran.* Solar Energy, vol. 15, 1973.
- [16] Bahadori, M.N. *Conceptual development of a solar town in Iran.* Solar Energy, Vol. 23, 1979.
- [17] Akbarzadeh, A. and Ahmadi, G. *Computer simulation of the performance of a solar pond in the southern part of Iran.* Solar Energy, Vol. 24, 1980.
- [18] American Society of Heating, Refrigerating, and Air Conditioning Engineers, ASHRAE. 1981 Fundamentals.
- [19] Griffiths, J.F. *Applied climatology, an introduction.* Oxford University Press, 1976.
- [20] Givoni, B. *Man, climate and architecture.* Elsevier Publishing Company, 1969.
- [21] Bitan, A. and Assif, S. *Climatic data analysis and its use and representation for planners.* Energy and Buildings, Vol. 1, 1984.
- [22] Bitan, A. *The Jordan valley project - a case study in climate and regional planning.* Energy and Buildings, Vol.4, No.1, 1982.
- [23] CIBSE GUIDE, Volume C, Section C1; Properties of humid air. The Chartered Institution of Building Services Engineers, 1986.

Chapter 3

BUILDING BIOCLIMATIC ANALYSIS

- 3.1 Introduction
- 3.2 Thermal comfort
 - 3.2.1 Air temperature
 - 3.2.2 Mean radiant temperature
 - 3.2.3 Humidity
 - 3.2.4 Air motion
 - 3.2.5 Clothing
 - 3.2.6 Activity
- 3.3 Thermal indices
 - 3.3.1 Fanger's Comfort Model
 - 3.3.1.1 *PMV* Thermal Index
 - 3.3.1.2 *PDD* Thermal Index
- 3.4 References

3.1 INTRODUCTION

After clothing, the shelter is the main instrument for fulfilling the requirement of comfort. Staying indoors, the occupants are not only sheltered against undesirable parameters of natural environment, i.e. rain, solar radiation, noise, etc., but also are exposed to a more constant and more comfortable thermal environment. Page[1] notes that the basic aim in the design of buildings should be to promote thermal comfort using minimum necessary inputs of non-meteorological energy. United Nations Centre For Human Settlements [2], advises the designer to create comfortable indoor climate by the use of bioclimatic design techniques and use of renewable sources of energy.

Indoor climate is often defined as the collective whole of all physical properties in a room which influence a person via his heat loss and respiration[3]. The most important variables are;

- *air temperature*
- *mean radiant temperature*
- *air velocity*
- *humidity*

Besides the above environmental factors, man's comfort is also affected by the following two individual factors;

- *activity level*
- *thermal resistance of clothing*

Thermal comfort can be achieved by an infinite number of

combinations of the values of above six variables provided that individually they lie within certain limits.

3.2 THERMAL COMFORT

Thermal comfort should not be confused with thermal equilibrium. Thermal comfort has been defined as "that condition of mind which expresses satisfaction with the thermal environment"[4]. So, for example, a thermally comfortable person would neither desire warmer nor cooler conditions if asked. Thermal equilibrium, on the other hand, involves keeping the temperature of the core tissues of the body within a narrow range of 36 to 38 °C regardless of the relatively wide variations in the external environment. Thermal equilibrium, while essential for comfort, can also be achieved under conditions of discomfort, through the activation of thermoregulatory mechanisms.

The maintenance of deep-tissue temperature, or core temperature at or near 37 °C when at rest is the principle object of the body's complex thermoregulatory system. Activity raises this temperature, even under comfort conditions. A deviation by up to 2 °C above or below this can be tolerated for a short time, but over longer durations, or a greater deviation, results in health hazards or death.

Maintaining body core temperature constant requires the involvement of several thermoregulatory mechanisms, primarily, the vasomotor

regulatory system, by which blood flow to the skin is regulated. At a given activity level, as the thermal environment becomes cooler, the blood vessels under the surface of the skin constrict (vasoconstriction), reduce the flow of blood and, thus reduce the surface temperature of the body and, hence, the rate of heat loss. Similarly, as the environment becomes warmer, the blood vessels expand (vasodilation), the skin temperature rises, and as the result, the heat loss increases.

When body temperature cannot be controlled by using the vasomotor regulatory systems solely, other physiological systems are recruited; goose pimples and shivering when body temperature is reduced and sweating when body temperature is increased.

Further cooling below the shivering region will cause a drop in body temperature, further heating above the level at which the whole body surface is covered with unevaporated sweat will cause body heating.

While core temperature is held constant over a wide range of ambient temperatures, skin temperature, T_{sk} , changes in response to changes in external environment. Therefore, the skin temperature plays an important role in the heat exchange process between the human being's body and its environment.

Skin temperature varies from place to place over the body. The mean skin temperature, for sedentary subjects, can be taken as [5];

$$T_{sk(\text{mean})} = 33.5 + 0.5 \quad (^\circ\text{C}) \quad (3.1)$$

As mentioned, the major environmental determinants of comfort are air temperature, mean radiant temperature, air velocity and humidity. In addition to the physical environmental factors, human thermal comfort is influenced by activity level and the thermal resistance of clothing. The effect of the above six factors on thermal comfort are studied in the following paragraphs. Other factors such as; age, sex, body build, etc. appear to have little or no practical effect upon the comfort conditions [3,6,7].

In practice, quantitative knowledge is needed as to which combinations of the above mentioned six variables will lead to thermal neutrality. According to the definition of comfort, it is requested that there be no local discomfort on the human body. That is to say that non-uniform effects such as the asymmetry of the radiant environment, the fluctuations of the air velocity, the vertical air temperature gradient, the floor temperature, etc. may cause discomfort even though the spatial integration of the thermal exchange is zero.

3.2.1 AIR TEMPERATURE

Although the core temperature of the body remains constant, the skin temperature varies in response to changes in environment. The heat produced in deep body tissues is continuously transported to the skin surface from where it must be transferred to the environment.

Assuming adequate air motion to remove films of stagnant air which

insulate the body from the room air, and consequently lower the heat transfer, convective heat transfer varies directly with the temperature difference between air and skin [8]. Therefore, the temperature of the air must be below the skin temperature if heat is to be dissipated by convection. As the temperature of the air rises, the difference in temperature between the skin and the air decreases, also the dissipation of heat by convection. At air temperatures above the mean skin temperature, the convective heat loss ceases and heat gain by convection would occur.

Allowing the inside temperature of an enclosure to drift with outside conditions and internal loads has important implications for energy saving, provided that the environment remains thermally acceptable to the building's occupants.

Sprague and McNall [9], studied the effect of temperature fluctuations on sedentary subjects wearing light clothes. While other variables were kept constant, they found that no serious occupancy complaints occur due to temperature fluctuations if;

$$t^2 * cph < 4.6 \quad (\text{ }^\circ\text{C}^2 / \text{h}) \quad (3.2)$$

Where, t is the peak to peak amplitude of the air temperature ($^\circ\text{C}$), and, cph is the cycling frequency per hour. For example, if $t = 1$ $^\circ\text{C}$, then $cph < 4.6$ cycle/h would be an acceptable cycling rate.

Berglund and Gonzales[10] showed that a temperature ramp of 0.6 $^\circ\text{C}/\text{h}$ between 23 and 27 $^\circ\text{C}$ was thermally acceptable to more than 80% of

the test population dressed in summer office clothes (0.5 clo).

Another fact which may cause discomfort in association with air temperature, is the vertical air temperature gradient. In most spaces in buildings, the air temperature is not constant from the floor to the ceiling; it normally increases with the height above the floor. If this increment is sufficiently large, local warm discomfort can occur at the head, and/or cold discomfort can occur at the feet, although the body as a whole is thermally neutral. To prevent this, the vertical air temperature difference between head and ankles should not exceed 3 °C [11 ,12].

3.2.2 MEAN RADIANT TEMPERATURE

The mean radiant temperature, which is a function of the areas, shapes, surface temperatures and emissivities of the enclosing elements viewed from that point, can be as important as air temperature in affecting thermal comfort of people. The radiation effect of inside surfaces can be used to some extent to balance higher or lower air temperatures. To maintain comfort at high ambient temperatures, a lower radiant temperature is required. Conversely, at lower air temperatures, radiant temperature has to be kept high to provide comfort. However, the complementary relationship between the air temperature and the mean radiant temperature has its limitations. In practice we should not find wide differences between air temperature and mean radiant temperature as this may lead to discomfort [13]. As an approximate

rule, discomfort will be experienced if the mean radiant temperature is higher than 8 °C above, or lower than 5 °C below the air temperature.

If the body sees surfaces with different temperatures, discomfort may rise due to the asymmetric radiation. CIBS Guide[13] lists three cases of asymmetric radiation which may lead to discomfort;

- 1 - *local cooling - radiation exchange with adjacent cold surfaces such as windows.*
- 2 - *local heating - radiation with adjacent hot surfaces such as hot ceilings.*
- 3 - *intrusion of short wavelength radiation such as solar radiation through windows.*

3.2.3 HUMIDITY

When the air and surrounding surface temperatures are above the skin temperature, convective and radiant elements in the heat exchange process are positive and the body will gain heat from the air and surrounding surfaces. In this case, the body thermal balance may still be maintained by increased evaporation.

Inside the limits of humidity acceptable for thermal comfort, i.e. between 20 to 80% relative humidity, the effect of humidity is not very significant. The extremes of humidity, low or high, may cause discomfort and should be avoided. The sensation of wettedness at high humidities, and the excessive dryness of lips and mucous

membranes of the upper respiratory tract at extreme low humidities can cause unpleasantness.

3.2.4 AIR MOTION

In order to be comfortable, heat and moisture must be carried away from the body as they are liberated or a stagnant film of warm, moist air would envelope the body. The effect of air movement on the body can be summarised in two ways; firstly, it determines the convective heat exchange of the body, and secondly, it affects the rate of evaporation from the body surface, and, hence, the evaporative heat loss.

When the air temperature is below the skin temperature, the two effects of air movement operate in the same direction. Thus, increases of air velocity, will increase the rate of heat loss to the environment and will be sensed first as cold draught then as wind-chill.

When the air temperature is above the skin temperature, say about 34 °C, then any increase in air velocity will, of course, increase the convection heat gain from the environment. But on the other hand, it increases the evaporation rate and, hence, the cooling efficiency. Experiments upon the effect of air velocity in such conditions show that there is an optimal air velocity, below this evaporative cooling is limited, above it convective heat gain more than counter-balances evaporative cooling.

Fanger[3] observes that in order to obtain a uniform thermal climate in the occupied zone of a room, one should attempt to keep the air velocities smaller than 0.1m/s where the heat transfer to the air is by free convection and therefore independent of the velocity.

Within the thermally acceptable temperature range of ASHRAE comfort zone[4], the maximum average air movement allowed in the occupied zone is lower in winter than in summer. In winter, the average air movement in the occupied zone should not exceed 0.15m/s. If the temperature is less than optimum, the maintenance of low air movement is important to prevent local draught discomfort. Draughts are more intolerable if the stream is directed onto the back of the neck since this part of the body is particularly sensitive to air movement. In general people are more tolerant of air movement where the direction varies[13].

In summer, ASHRAE sets the limit of 0.25 m/s for average air movement in the occupied zones.

3.2.5 CLOTHING

Outside the body, heat transfer can be controlled by clothing. Clothing forms a barrier to the body which controls convective and radiative heat exchange between the body and its environment. It also interferes with the process of sweat evaporation.

Transfer of dry heat between the skin and the outer surface of the

clothed body is complicated, involving internal convection and radiation processes in intervening air spaces, and the conduction through the cloth itself.

As a simplification, the properties of clothes can be considered in terms of their total thermal resistance. Gagge[14], introduced the unit "clo", which is a dimensionless expression for the thermal insulation of clothing. The clo-unit has been generally accepted and today is used in most parts of the world.

The standard clo unit is equal to $0.155 \text{ m}^2\text{K/W}$, and this represents approximately the thermal resistance, R_{cl} , of a lounge suit with normal underwear. If R_{cl} for any particular clothing ensemble is known from measurement, expressed in terms of the Dubois area, then its insulation value in clo units will be;

$$I_{cl} = R_{cl} / 0.155 \quad (3.3)$$

During the winter months, people tend to wear heavier clothes than in summer. Values of 0.3 to 0.6clo for summer and 0.8 to 1.2clo can be considered to represent the thermal insulation of typical clothing worn in summer and winter respectively. At other times, between seasons, the clothing may have an insulation value in the range of 0.6 to 0.8clo [12].

The higher the clo value, the higher the insulating effect of the clothing and the higher the tolerance of the wearer to low temperatures. Humphreys[15] has pointed out that an individual may find it more acceptable to function by intermittent activity levels,

of rest and work, if the person is lightly dressed in a comfortable environment than if he/she is heavily dressed in a cool environment.

It is interesting that the temperature criteria for thermal comfort have risen steadily by about 5 °C since 1900 [16]. This increasing trend probably results from year-round use of lighter-weight clothing worn in indoor environments, and from changing living patterns. This trend may however, be associated with increased body size, diets, comfort expectations, etc.

Table 3.1 shows a typical range of combinations of clothing together with their typical *clo* values.

Table 3.1
Values of *clo* for various clothing ensembles [17]

Clothing ensemble	<i>clo</i>
Nude	0.0
Shorts	0.1
Tropical ensemble(shorts, open-neck short-sleeved shirt, light socks, sandals or women's equivalent)	0.3-0.4
Men's light summer clothing (long light weight trousers, open-neck short-sleeved shirt)	0.5
Typical men's business suit (+ cotton underwear, long-sleeved shirt, tie, woollen socks, shoes)	1.0
Men's heavy three-piece business suit (+ cotton underwear, long-sleeved shirt, tie, woollen socks, shoes)	1.5
Women's indoor ensemble (skirt, long-sleeved blouse and jumper, normal underwear, stockings, shoes)	0.7-0.9
Men's heavy suit as above + woollen overcoat	2.0-2.5

3.2.6 ACTIVITY

The comfort conditions are also related to the level of physical activity. The metabolic rate (M), the energy released by the oxidation processes in the human body, is mainly proportional to the extent of physical activity, so that with an increase in the metabolic rate, more oxygen is required by the working muscles and higher quantities of heat have to be transferred from the body-core to the skin and dissipated into the external environment.

For the body as a "machine" using food as fuel we can write;

$$\text{Food} + \text{Oxygen} = \text{Heat} + \text{Work} \quad (3.4)$$

or;

$$M = H + W \quad (3.5)$$

Where;

M = metabolic rate per unit time.

H = the internal (free energy) heat production in the human body.

W = mechanical work accomplished.

W and M usually are expressed per unit area of body surface, this allowing for people of different size and shape. A very good estimate of the body surface area is given by the Dubois equation[17], for the Dubois area (A_{du});

$$A_{du} = 0.2024 * W_b^{0.425} * H_b^{0.725} \quad (3.6)$$

Where;

A_{du} = Dubois surface area, m^2
 W_b = body weight, Kg
 H_b = body height, m

Typical values for adult males and females range from 1.65 to 2.00 square metres, with 1.80 as a reasonable single figure adult average [17].

The external mechanical efficiency, n , can be defined as;

$$n = W/M \quad (3.7)$$

The efficiency with which a task is carried out depends most of all on the task and the rate of working. The fitness and training of the person also modify the efficiency[18]. In most daily activities no external work is performed, indicating a value of zero for n . Mechanical efficiencies of some activities are given in table 3.2.

Values of M/A_{du} are characteristics of different activities, ranging from 41 W/m^2 for sleeping to 200 W/m^2 and over for prolonged heavy physical work or athletics. Sitting rate is 58 W/m^2 , a value designated as one metabolic unit, expressed in "met". Table 3.2 shows values of M/A_{du} for different activities in W/m^2 and *met* and the efficiency (n) of the task carried out. From this table, one can see that the maximum values of n hardly approaches 0.2.

Table 3.2
Metabolic rates of different activities and their mechanical efficiencies [17]

Activity	Metabolic rate (W/m ²)	(mets)	Mechanical efficiency
Sleeping	41	0.71	0
Reclining	47	0.80	0
Sitting	58	1.00	0
Standing, relaxed	70	1.20	0
Walking, level, at 3.2 Km/h	116	2.00	0
Walking, level, at 4.8 Km/h	151	2.60	0
Walking, level, at 6.4 Km/h	221	3.80	0
Walking, 15 degrees upward slope, at 3.2 Km/h	267	4.60	0.1
House cleaning	116-198	2.00-3.40	0-0.1
Typing	70-81	1.20-1.40	0
Gymnastics	175-233	3.00-4.00	0-0.1
Dancing	140-256	2.40-4.40	0
Sawing by hand	232-280	4.00-4.80	0.1-0.2
Heavy machine work	204-262	3.50-4.50	0-0.1

3.3 THERMAL INDICES

From the beginning of this century, many attempts have been made to produce methods of quantifying the effect of different variables on the thermal comfort of the human beings. There are many indices to describe the environment in terms of comfort. One of the most widely used model in thermal comfort analysis is the so called "comfort equation" of Fanger[3]. The Fanger's equation which is

supported in ESP has been used in this study in assessing the effect of design modifications on the thermal conditions of enclosures.

The comfort equation of Fanger is based on experiment with American college-age subjects. It is often maintained that comfort conditions are different for different national-geographic locations. The question thus rises to what extent the equation can be used for other national-geographic locations.

Fanger through experiments performed in Denmark established that the equation can be readily used within the temperate zones as the results of investigations did not indicate any significant differences in thermally neutral conditions preferred by the American and Danish subjects.

The comfort equation, however, needed to be examined for its applicability in geographic locations outside the temperate climates as well, e.g. in the tropics, where people are more or less acclimatised to hot environment.

Acclimatisation to heat is a well established phenomenon. For those who are accustomed to live in temperate climates, on the initial exposure to heat, physiological strain may be experienced and the ability to perform muscular work will be impaired and if the conditions are sufficiently severe, some acute heat disorder may take place. However, in the course of a period of one or two weeks, the ability to endure the environment will gradually improve, and the working capacity will increase.

To investigate the applicability of the comfort equation in tropics, Fanger made a comparison between the estimated temperatures for optimum comfort using the equation and the results of field studies from different geographical locations in the tropics. The comparisons showed that there exists a close agreement between the optimum temperatures estimated by the comfort equation and the measured temperatures. As the differences between the results from field studies in the tropics and the comfort equation are small (less than 1 °C) and probably not of engineering significance, the comfort equation can be safely used in thermal performance assessments of buildings in hot dry climates.

It should be noted that the clo-value is inserted as a variable in the comfort equation. Values corresponding to the actual clothing habits at a given national-geographic location therefore should be considered in applying the equation.

3.3.1 FANGER'S COMFORT MODEL

Fanger[3], based on experimentally determined physiological comfort criteria and heat transfer theory, derived the comfort equation, which determines all combinations of the six main parameters, namely; air temperature, humidity, air motion, mean radiant temperature, activity and clothing worn, which will provide thermal neutrality for human beings.

Subsequently, he derived the Predicted Mean Vote (*PMV*) and Predicted

Percentage of Dissatisfied (*PPD*) indices which predict the degree of discomfort and the percent of people who will experience discomfort for any combination of the six comfort parameters measured in practice.

3.3.1.1 PMV THERMAL INDEX

The thermal sensation index derived by Fanger, *PMV*, gives the predicted mean vote of a large group of persons exposed to a given combination of variables. Fanger proposes to measure the degree of discomfort in terms of the thermal load placed on a person in a given environment. The thermal load is defined as the difference between the internal heat production and the heat loss to the actual environment for a man hypothetically kept at the comfort values of the mean skin temperature and the sweat secretion at the actual activity level. The index calculates this load, and then, establishes a relationship between the predicted vote, on the seven-point scale; and the load. Fanger has used the commonly used seven point psycho-physical ASHRAE scale as a measure for the thermal sensation. The scale is as follows;

-3	cold
-2	cool
-1	slightly cool
0	neutral
+1	slightly warm
+2	warm
+3	hot

3.3.1.2 PPD THERMAL INDEX

The thermal sensation index (PMV), gives the predicted mean vote of a large group of persons exposed to a given combination of the variables. The mean vote is indeed an expression for the general degree of discomfort for the group as a whole, but it is nevertheless difficult to interpret what the magnitude of PMV determined in a practical case can imply.

Fanger established a relationship between the Predicted Percentage of Dissatisfied (PPD), and the mean vote (PMV), by analysing the votes obtained in experiments. He found that for a mean vote of zero, PPD is 5% (figure 3.1). This point corresponds to the optimal comfort condition. He suggests that in practice, the number of dissatisfied should not be more than half as large as the minimum value, i.e., $PPD = 7.5\%$, this corresponds to $PMV = \pm 0.35$.

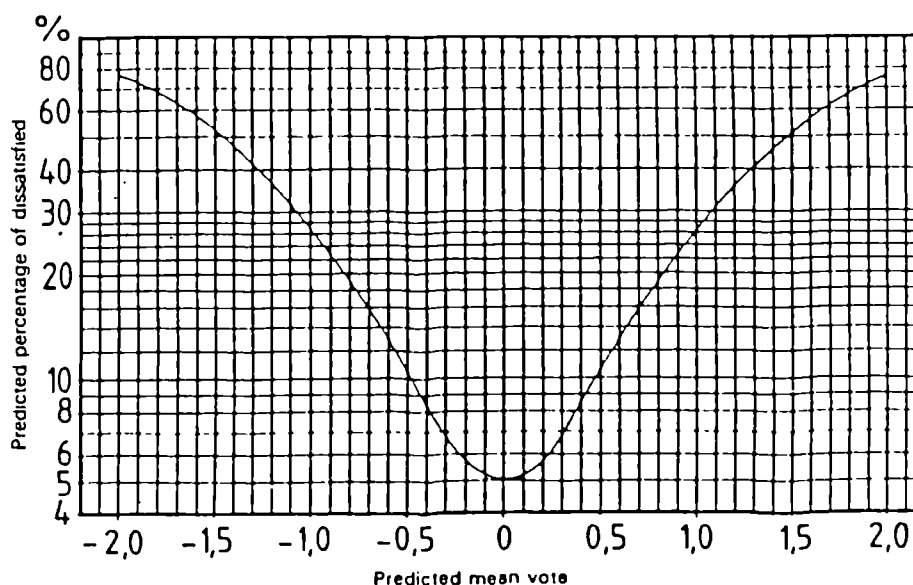

Figure 3.1 Predicted Percentage of Dissatisfied (PPD) as a function of Predicted Mean Vote (PMV) [3]

3.4 REFERENCES

- [1] Page, J.K. *Application of building climatology to the problems of housing and building for human settlements*. Technical Note No. 150, World Meteorological Organisation (WMO), No. 411, 1976.
- [2] *Case studies on measures for energy-efficient shelter and infrastructure*. United Nations Centre For Human settlements (Habitat), Nairobi, 1986.
- [3] Fanger, P.O. *Thermal comfort, Analysis and application in environmental engineering*. McGraw-Hill Book Company, 1970.
- [4] American Society of Heating, Refrigeration, and Air-Conditioning Engineers, ASHRAE, *Handbook of Fundamentals*, New York, 1977.
- [5] Fanger, P.O. *Conditions for thermal comfort - A review*. Proceedings of the CIB commission W45 (Human requirements) symposium, BRE, 13-15 Sept. 1972. Thermal comfort and moderate heat stress, BRE report 2, HMSO, London, 1973.
- [6] Rohles, F.H., Nevins, R.G. *The nature of thermal comfort for sedentary man*. ASHRAE Transactions, Vol.77, Part 1, 1971.
- [7] McNall, P.E., Ryan, P., Jaax, J. *Seasonal variations for college - aged persons in the Middle West*. ASHRAE Transactions, Vol.74, 1968.
- [8] Watt, J.R. *Evaporative air conditioning handbook*. Chapman & Hall, 1980.
- [9] Sprague, C.H. , McNall, P.E. *The effect of fluctuating temperature and relative humidity on the thermal sensation of sedentary subjects*. ASHRAE Transactions, Vol.76, Part 1, 1970.
- [10] Berglund, L.G., Gonzalez, R. *Human response to temperature drifts*. ASHRAE Journal, August 1978.
- [11] Fanger, P.O. *Thermal comfort in indoor environments*. Proceedings of symposium on thermal analysis - human comfort - indoor environments. National Bureau of Standards, Maryland, USA, 11 February, 1977.
- [12] McQuiston, F.C., Parker, J.D. *Heating, ventilating and air - conditioning, Analysis and design*. John Wiley & Sons, 1988.
- [13] CIBSE Guide, *Environmental criteria for design*. CIBS Guide, Section A1, 1978.
- [14] Gagge, A.P., Burton, A.C., Bazett, H.C. *A practical system of units for the description of the heat exchange of man with his environment*. Science, Vol.94, 1941.

- [15] Humphreys, M.A. *Field studies of thermal comfort compared and applied. Proceedings of the symposium on physiological requirements of the microclimate.* Prague, Czechoslovakia, 1975.
- [16] Rohles, F.H., Nevins, G. *Thermal comfort: New directions and standards.* *Aerospace Med.* 44(7), 1973.
- [17] Markus, T.A., Morris, E.N. *Buildings, climate and energy.* Pitman, 1980.
- [18] McIntyre, D.A. *Indoor climate.* Applied Science Publishers, 1980.

Chapter 4

HEAT FLOW THROUGH THE BUILDING FABRIC

- 4.1 Introduction.
- 4.2 Energy flow across the fabric.
- 4.3 The effect of thermal mass and insulation on heat flow through the fabric.
- 4.4 The effect of the masonry thickness on the heat flow through walls.
- 4.5 The effect of insulation thickness on the heat flow through walls.
- 4.6 surface characteristics with respect to radiation.
- 4.7 The effect on heat flow of colour, orientation, and thermal resistance of the fabric.
- 4.8 References.

4.1 INTRODUCTION

In Chapter 2, the climatological parameters which have the main impact on the building design were studied. It was shown that hot dry climates experience extreme ranges in the climatic variables. Thermal comfort of the occupants, however, may be achieved provided climatic (and also individual) variables, as discussed in Chapter 3, are within certain limits. One of the main functions of the building fabric, as the main filter or barrier between the external and internal environment, is fulfilling the requirements of comfort. This should be achieved by using minimum necessary inputs of non-meteorological energy. The objective of this chapter is to determine how the thermal characteristics of the fabric regulate heat flow through it.

4.2 ENERGY FLOW ACROSS THE FABRIC

The three thermal characteristics of a building element, e.g., a wall, which may significantly affect the energy flow across it are its thermal transmittance, i.e. its U-value, its ability to store heat, i.e. its thermal storage capacity and the relative position of the insulation to the masonry [1]. The thermal transmittance, U-value, is defined as:

$$U = \frac{1}{R_{si} + R_1 + R_2 + \dots + R_{so}} \quad (4.1)$$

Where;

U = thermal transmittance, W/m^2K

R_{si} = inside surface resistance, m^2K/W

R_1, R_2 = thermal resistance of structural components, m^2K/W

R_{so} = outside surface resistance, m^2K/W

R , the thermal resistance of unit area of an element of homogeneous material may be calculated as;

$$R = \frac{L}{\lambda} \quad (m^2K/W) \quad (4.2)$$

Where, L is the thickness of the material in metres and λ , its thermal conductivity (W/mK).

Although wall systems are frequently characterised by their heat transmission coefficients, this does not adequately describe their thermal performance under unsteady state conditions. This is because the steady state theory does not include the effect of thermal capacity nor its distribution within the wall.

It should be noted that ESP does not use the concept of U - value in energy flow calculations. To make the comparison between the thermal behaviour of different wall systems valid, the design modifications were adjusted to give the same nominal U -values which were separately calculated.

Thermal heat storage capacity of a structure is its ability to store heat. Materials are heated differently by the same quantity of

heat, according to the product of their specific heat and density. The thermal capacity of a homogeneous structure may be defined as the product of its thickness, density and specific heat (J/m^2K).

4.3 THE EFFECT OF THERMAL MASS AND INSULATION ON HEAT FLOW THROUGH THE FABRIC

The thermal behaviour of a structure is influenced by its ability to modify energy flows through time lag (as the result of the thermal capacity) and amplitude attenuation (primarily a result of the diffusion of energy).

The thermal heat storage capacity of the materials of conventional building construction, e.g. walls, affects the energy flow pattern through them. This can be explained as follows; as the heat enters the outer surface of a wall, the first layer of particles absorbs some heat before any heat is transmitted to the next layer. This has a delaying effect on the heat flow and a certain amount of heat is stored in the wall. This stored heat is then emitted with a considerable time delay after the heat input ceased.

Through architectural design, this characteristic of the thermal storage capacity of construction should be utilised to improve the thermal performance of the building.

Much attention has been given recently to the influence of thermal mass on the energy flow through building elements[1 - 12].

Childs [2] in a qualitative manner, has illustrated the effect of the thermal mass on the pattern of the heat flow through walls exposed to sinusoidal temperature variation on the outside and a fixed temperature on the inside. As illustrated in figure 4.1, the thermal storage capacity of the wall has modified the heat flux at the inside surface through time lag and amplitude reduction. Walls have been chosen to produce lag times of 3, 6 and 12 hours. In part (a) of each diagram, the actual heat flux for an entire cycle is plotted along with the heat flux calculated by assuming that steady-state conditions always exist. In part (b), the change in heat flux resulting from the mass is plotted. This change is simply the difference between the actual and steady-state values.

The effect of thermal mass and insulation on the energy flow through an exterior wall is shown in figure 4.2. Case A illustrates the energy flow through a perfectly conductive wall. Case B is the same as case A except that in addition the effect of insulation has been shown. The maximum and minimum energy flows have occurred on the same hours. In case C, the energy flow is shown for a massive wall assuming an equivalent U - value to the case A. In this case, due to the effect of thermal mass, there is a time delay as well as amplitude reduction in energy flow through the wall. In case D, the maximum and minimum energy flows are further attenuated as the result of the compound effect of thermal mass and insulation.

3 hours lag

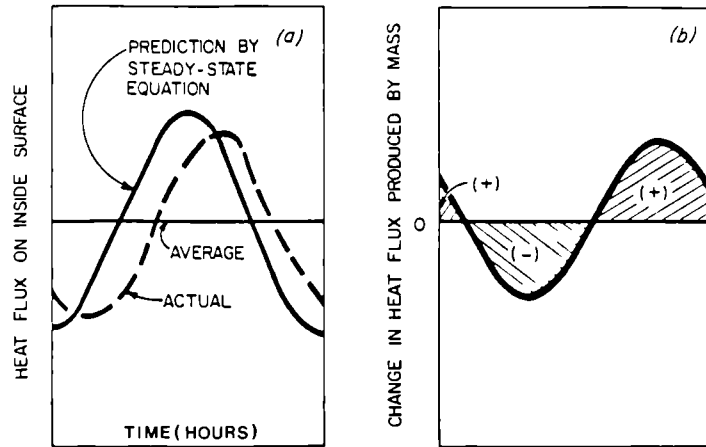

6 hours lag

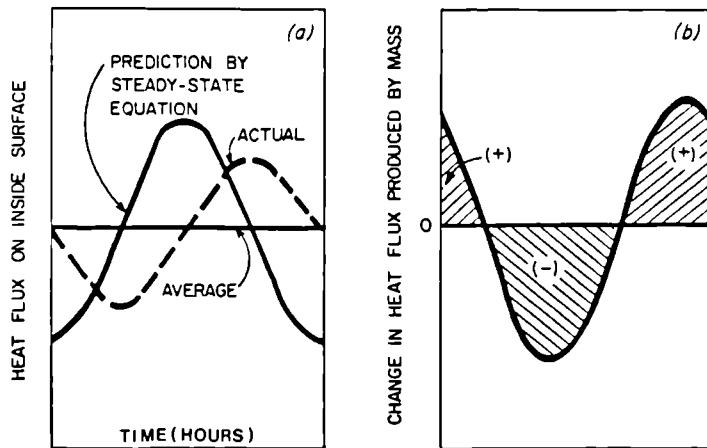

12 hours lag

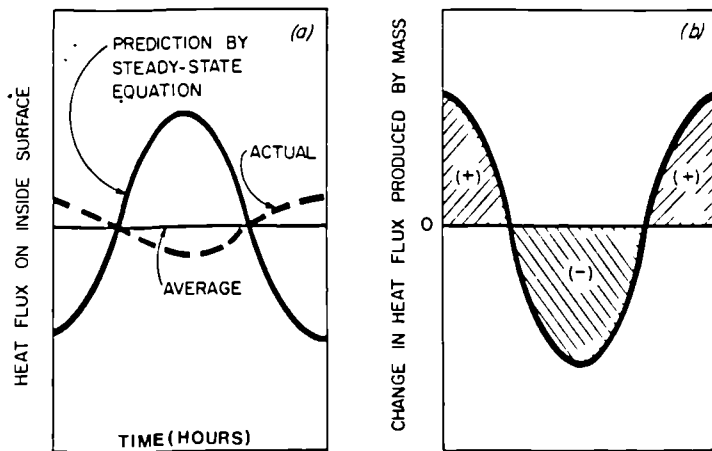

Figure 4.1 Heat flux at the inside surface of a homogeneous wall [2]

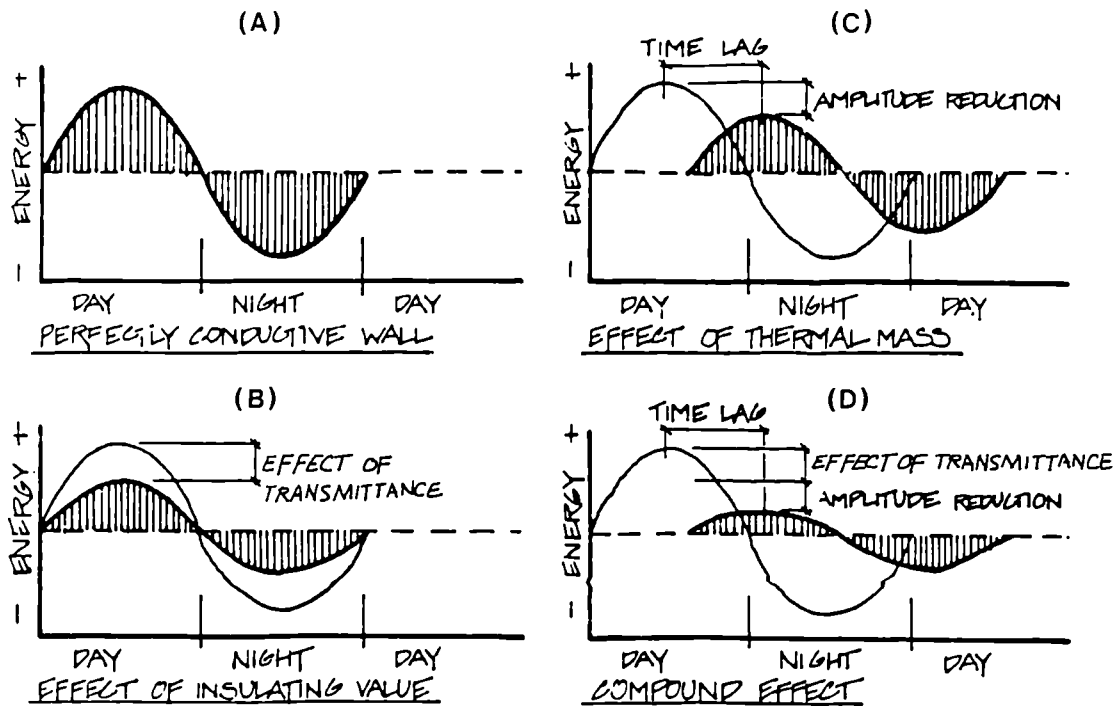

Figure 4.2 Diagrammatic representation of effect of thermal mass and thermal transmittance on the energy flow through an exterior wall [3]

From figures 4.1 and 4.2, it is clear that thermal mass does not influence the average or total heat flow through the wall. For example, as is shown in parts (b) of figure 4.1, the area marked with a plus sign (indicating an increase in heat flux compared to steady-state) is equal to the area marked with a minus sign (indicating a decrease). Thermal mass does however modify the pattern of energy flow, e.g. by shifting the occurrence of the maximum heat flux at the internal surface of the element and reducing its amplitude. Through architectural design, if this property of thermal mass is utilised properly, it can reduce or even eliminate the necessary auxiliary energy supply and/or removal to/from the building in order to maintain comfort.

To analyse the effect of thermal mass and insulation on the energy usage of buildings, a series of simulations were performed. In the simulation runs the results of which are reported here, a wall of dimensions 3 by 3 metres was considered as the test wall. The wall comprised the south facing wall of a box of dimensions 3 by 3 by 3 metres and experiences the climate of the city of Yazd, Iran. The other 5 surfaces of the box are of insulating materials (with little thermal heat storage capacity) surrounded by spaces thermally identical to the box. The temperature of the box was kept fixed at 22 °C. In order to have no heat flow path between the box and its surroundings except through the test wall, all other means of heat gain/loss, i.e. by ventilation, internal gains etc., were set to zero. No openings were provided so as to eliminate heat gain/loss through windows. The conditions set, to some extent, represent the calibrated hot boxes used in laboratory test studies for determining thermal behaviour of building elements, with the outside chamber experiencing the actual climatic conditions of Yazd. The test conditions set above have been applied to all the simulation runs whose results are reported in this chapter unless other conditions have been specified otherwise.

The heat flux at the inside surface of the wall, Q_w , can therefore be determined from predictions of the amount of energy input/removal to/from the box to maintain its temperature constant. Thus;

$$Q_w = | Q_p | \tag{4.4}$$

Where Q_p is the heat that would have to be supplied or removed by the plant.

The results of simulation runs for 6 test walls are reported here.

The test specimens were as follows;

- 1) 10mm insulation panel (U - value = 2.26 W/m²K)
- 2) 220mm brickwork (U - value = 2.26 W/m²K)
- 3) 27mm insulation panel (U - value = 1.13 W/m²K)
- 4) Externally insulated 220mm brickwork (U - value = 1.13 W/m²K)
- 5) Internally insulated 220mm brickwork (U - value = 1.13 W/m²K)
- 6) Insulated cavity brickwork (U - value = 1.13 W/m²K)

The U-values of the test specimens have been calculated using equation 4.1 and assigning values of 0.12 m²K/W and 0.06 m²K/W for R_{si} and R_{so} respectively given in reference 13.

It should be noted that ESP treats the radiation and convection thermal coefficients at the surface of the building elements separately. Heat transfer by longwave radiation exchange between internal surfaces in visual communication and between the exposed external surfaces and the surroundings are based on linearised longwave radiation coefficients. Most building thermal models currently treat the convection at room surfaces as being equivalent to the natural (or buoyancy-driven) convection on an isolated surface. Likewise, the internal convection coefficients are calculated by ESP at each time-step using the improved data correlations for buoyancy-driven convective heat transfer from the internal surfaces of buildings proposed by Alamdari and Hammond [14]. The correlations provide a reasonably good approximation to

the results reported of the heat transfer for isolated surfaces [15]. The forced convection at the exposed external surfaces is treated based on the expression proposed by Mc Adams [16]. The techniques implemented into ESP are explained in reference [17].

To make the comparison between the thermal behaviour of the specimen walls valid, the thickness of insulation panels was adjusted to give the same nominal U-values as those for uninsulated and insulated brick walls respectively. Under steady state conditions, one can assume that the only influential property is the U-value, meaning that for example, the 220mm brick wall and 10mm insulation panel having the same U-value would thermally behave the same. Or, reducing the U-value of a specimen by half, e.g. by increasing its thickness, or by applying insulation materials to it, would reduce the heat flow through it by half. One of the objectives of this section is to highlight that u-value by itself is not a good indicator of the thermal performance of building elements under unsteady state conditions. The surface characteristics of all walls in respect to radiation are the same (absorptivity = 0.5, emissivity = 0.9).

Figures 4.3 to 4.8 illustrate the thermal behaviour of the test specimens. Data is output on the 3rd day of a simulation period corresponding to 21th of July. A 14 day pre-conditioning periods has been used to enable the initial conditions to stabilise. Plotted in these figures are the external air temperature, the external and internal surface temperatures of the test wall and plant load which also represents the heat flux at the inside surface of the wall.

In these figures, at any time, the distance between the curve and the line of zero energy transfer represents the rate of heat flux at the internal surface of the wall. Negative signs indicate heat gains and positive signs heat losses respectively. As the curve also represents the plant load at any time to maintain the constant temperature, the amount of energy which has to be extracted (cooling load) or injected (heating load) by the plant can be read off from the curve. The area on the graph below the zero line and bounded by the curve represents the total inward heat flux or the total cooling load. Similarly, the area above the zero line and bounded by the curve represents the total outward heat flux or heating load.

In the following paragraphs the time lag of a specimen is defined as the difference (hours) between the time of the occurrence of its maximum values of external and internal surface temperatures. The amplitude reduction (due to the thermal heat storage capacity) is the ratio of the magnitude of the maximum heat flux at the internal surface of the masonry wall, to the corresponding value at the internal surface of the insulation panel having the same u-value.

Figure 4:3 illustrates the behaviour of the 10mm insulation panel having a U-value of $2.26 \text{ W/m}^2\text{K}$. The heat storage capacity of this specimen is negligible ($0.12 \text{ KJ/m}^2\text{K}$). The maximum external and internal surface temperatures peak at about 12.30pm. and therefore there is no distinguishable time lag.

- 1 - Heat flux at the inside surface of the wall
- 2 - External surface temperature of the wall
- 3 - Internal surface temperature of the wall
- 4 - External dry bulb temperature

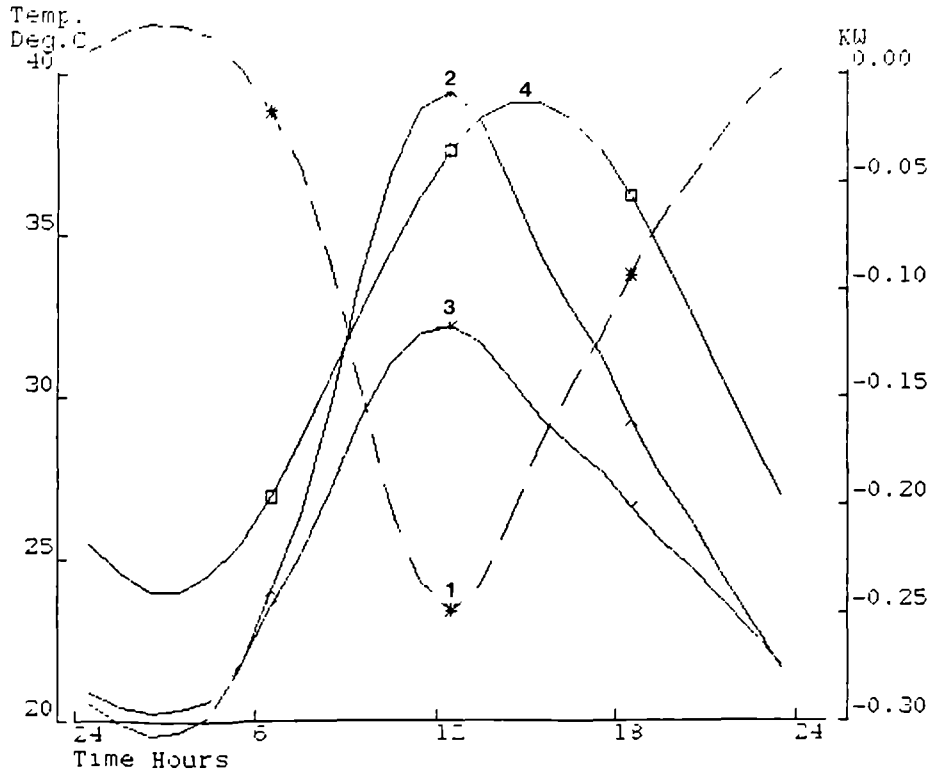

Figure 4.3 Thermal performance of the 10mm insulation panel

In figure 4.4, the case for the 220mm brickwork is shown. U-value of the wall is the same as that for the 10mm insulation panel. The available thermal heat storage of this wall ($299.2 \text{ Kj/m}^2\text{K}$) has caused a time lag of 6 hours. The maximum heat flux is 51% of the corresponding value for the 10mm insulation panel (amplitude reduction =0.51).

- 1 - Heat flux at the inside surface of the wall
- 2 - External surface temperature of the wall
- 3 - Internal surface temperature of the wall
- 4 - External dry bulb temperature

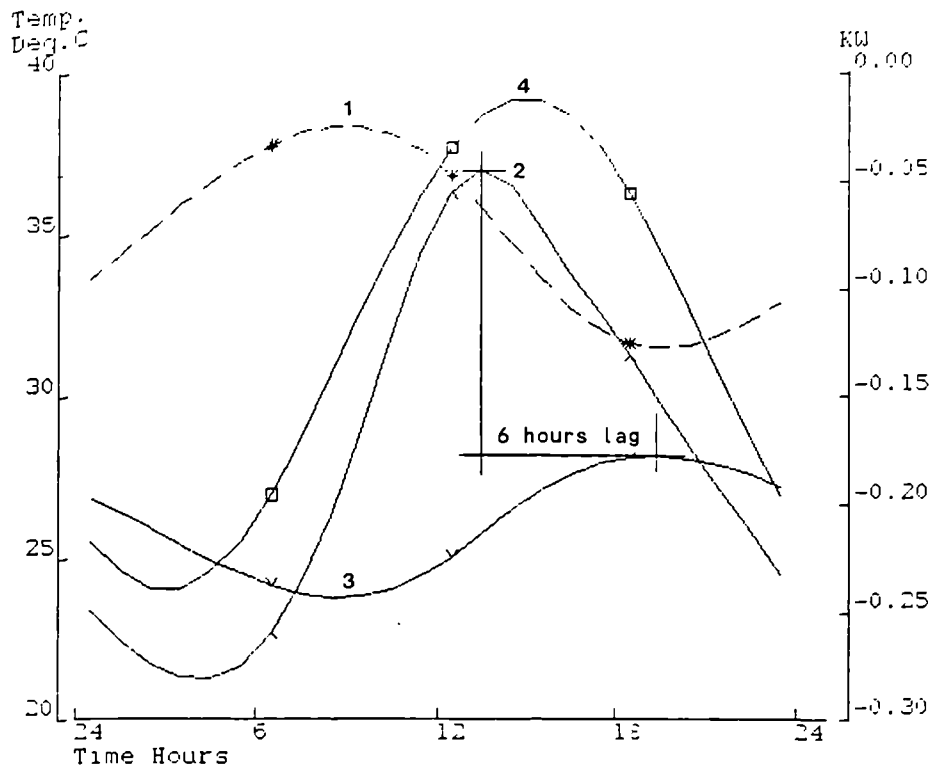

Figure 4.4 Thermal performance of the 220mm brick wall

As would be expected, increasing thermal resistance of the wall also has an effect on the heat flow through it. Decreasing the U-value of the 10mm insulation panel from 2.26 to 1.13 W/m²k (doubling its resistance) by increasing the thickness of the panel to 27mm, reduces the heat flow into the room. Since the amount of added mass is negligible (density of insulation is taken to be 15 kg/m³), no thermal lag is still distinguishable (figure 4.5). The increased thermal resistance has caused a reduction in the heat flux so that the maximum heat flux has been reduced to 57.8% of that for the 10mm insulation panel. The total plant load (cooling and heating loads) has been reduced by 40% compared with the case of the 10mm panel.

- 1 - Heat flux at the inside surface of the wall
- 2 - External surface temperature of the wall
- 3 - Internal surface temperature of the wall
- 4 - External dry bulb temperature

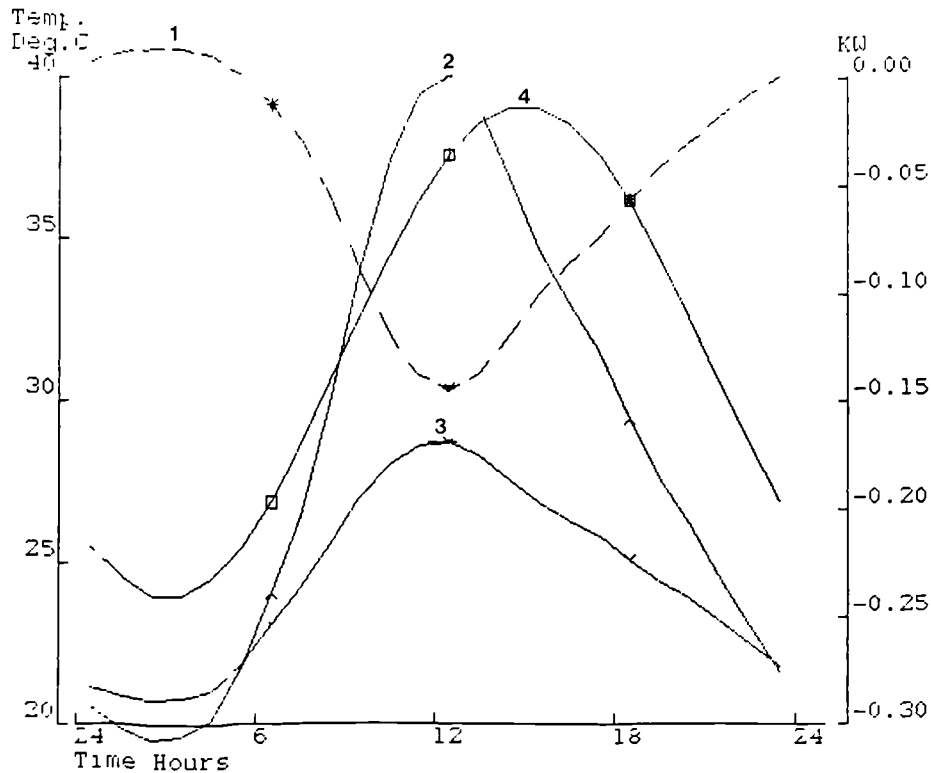

Figure 4.5 Thermal performance of the 27mm insulation panel

Decreasing the U-value of the 220mm brickwork to half, may be achieved by applying insulation to it. To investigate the effect of relative position of insulation to masonry, 3 cases were analysed; firstly insulation was placed outside the brickwork, secondly inside and finally it was placed between two layers of brickwork of equal thickness of 110mm, i.e. the case of an insulated cavity brick wall. In each case 17mm insulation was used to reduce the U-value of the wall to the new value of $1.13 \text{ W/m}^2\text{K}$.

Figure 4.6 illustrates the thermal performance of the externally insulated wall. The time lag has been increased by three hours,

from 6 to 9 as the result of adding insulation. The maximum heat flux at the internal surface of the wall is reduced significantly giving an amplitude reduction value of the order of 0.4. The heat flux curve for the insulated wall shows a smaller amplitude than the case of the uninsulated wall so that the maximum heat flux is only 45% of that for uninsulated brickwork. The daily load of the plant has also been reduced substantially to 60% of that for the uninsulated wall.

- 1 - Heat flux at the inside surface of the wall
- 2 - External surface temperature of the wall
- 3 - Internal surface temperature of the wall
- 4 - External dry bulb temperature

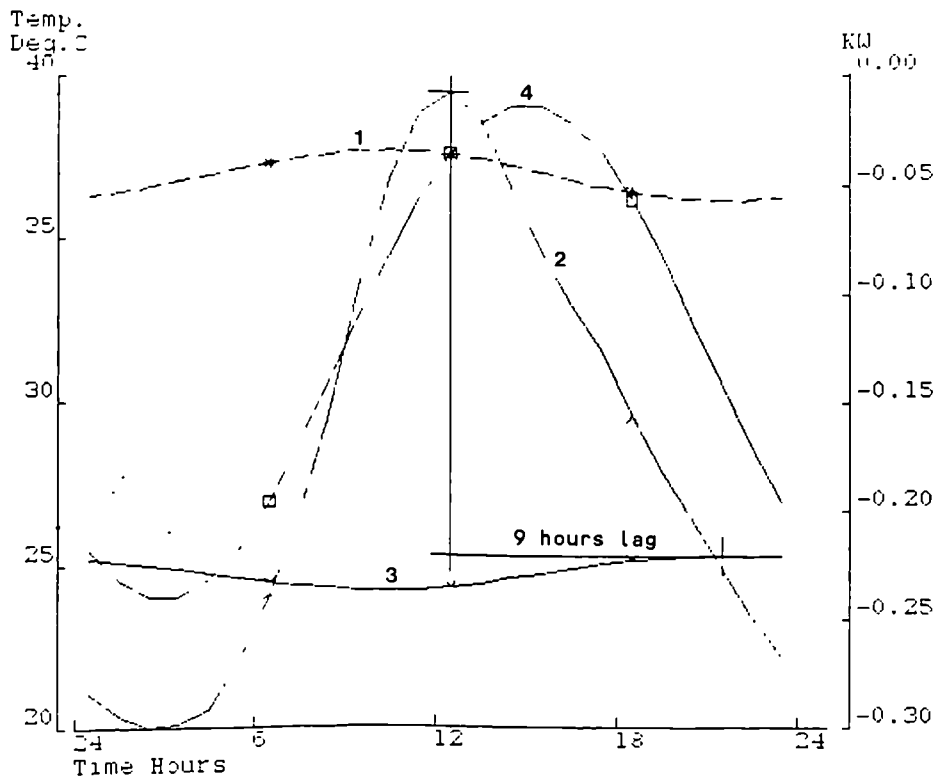

Figure 4.6 Thermal performance of the externally insulated brick wall

When insulation is added to the inside surface of the brickwork, the heat which has already traversed through the masonry almost instantaneously passes through the insulation as its thermal heat storage capacity is negligible. As shown in figure 4.7, the time lag of the internally insulated brickwork has not been changed as the result of adding insulation. The calculated value of the amplitude reduction is 0.49. This is almost 23% greater than the corresponding value for the externally insulated wall. The calculated maximum heat flux at the internal surface of the internally insulated wall is 55% and 123% of those of the uninsulated and externally insulated walls respectively.

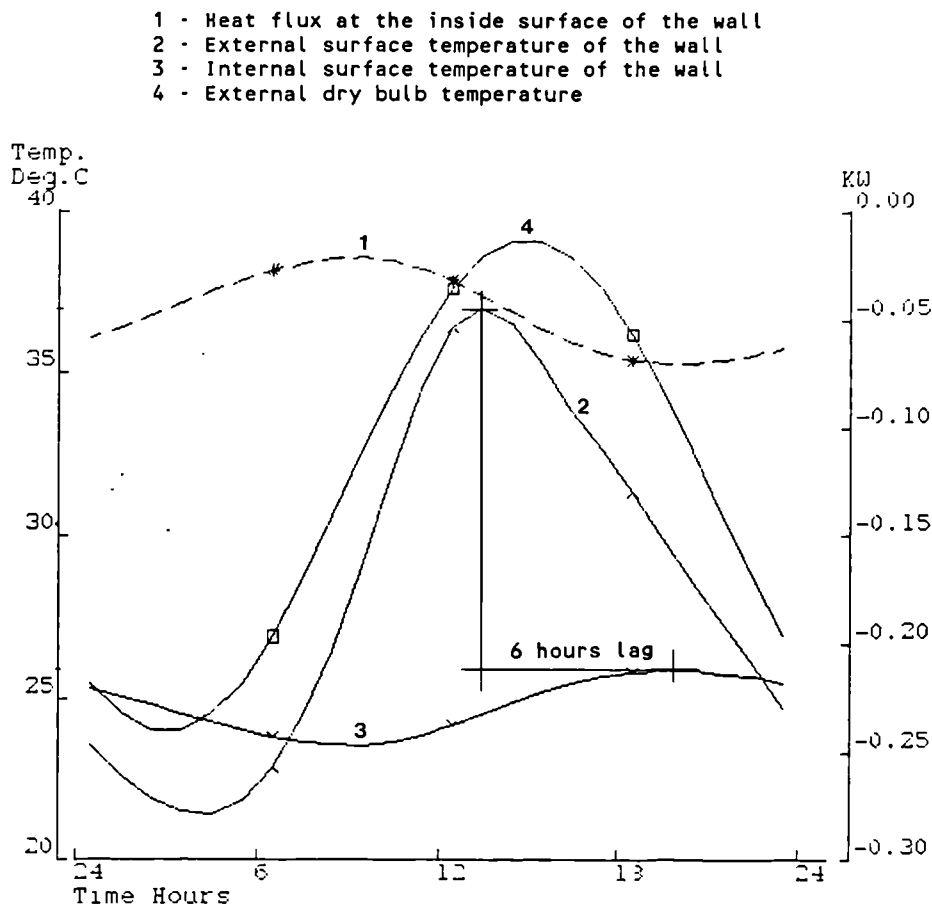

Figure 4.7 Thermal performance of the internally insulated brick wall

In the case of the insulated cavity wall, figure 4.8, a time lag of 9 hours was calculated. The calculated amplitude reduction for the cavity wall is 0.44. The maximum heat flux at the inside surface of the insulated cavity wall is 112% and 91% of the corresponding values for the externally and internally insulated walls respectively.

- 1 - Heat flux at the inside surface of the wall
- 2 - External surface temperature of the wall
- 3 - Internal surface temperature of the wall
- 4 - External dry bulb temperature

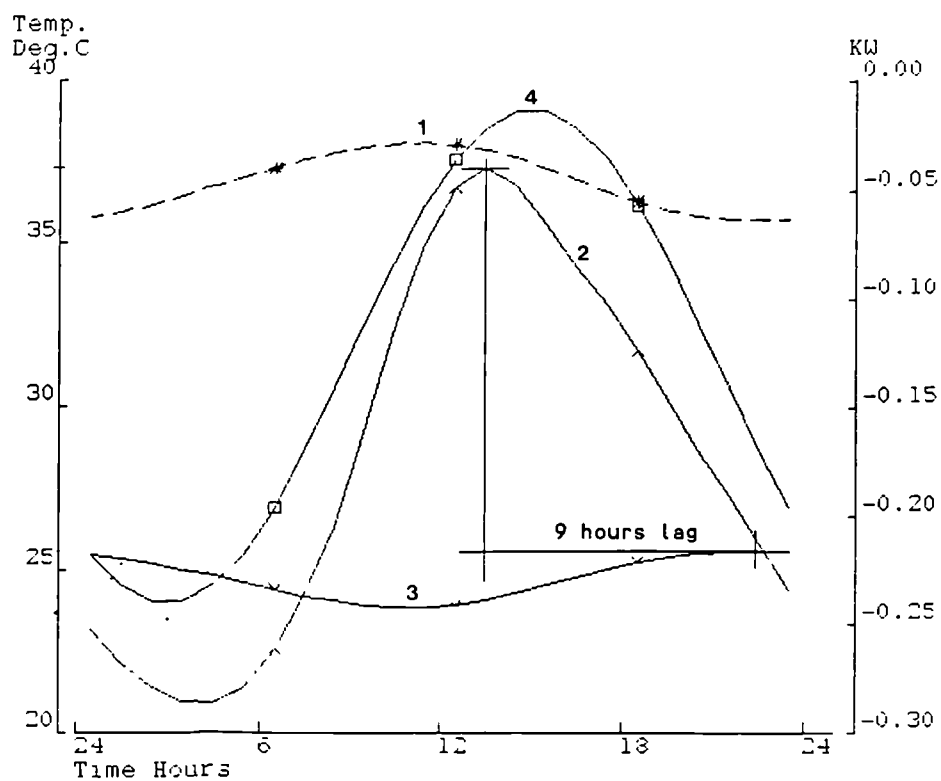

Figure 4.8 Thermal performance of the cavity brick wall

Figure 4.9 illustrates heat fluxes through one square metre at the inside surfaces of the walls. As the figure clearly shows the heat flux at the internal surface of walls having higher thermal heat storage capacities is smoother and there is a delay in the time of the occurrence of the peak values compared to the thermally lighter walls. For the case of insulation panels there is an outward flux at early morning hours indicating the need for heat injection by the plant.

Table 4.1 summarises some of the results of simulation runs for the 6 test walls.

The time delay and peak attenuation caused by thermal mass can be used to provide opportunities to lessen and shift the impact of the high solar gains and ambient temperatures of midday to the evening hours where the ambient temperatures fall and ventilative cooling might be used to advantage.

The thermal behaviour of different walls may be visualised by plotting temperature rakes across them. In order to investigate the effect of thermal heat storage, simulation runs were performed for homogeneous walls of the same thickness (200mm) having the same thermal conductivity and specific heat with a U-value of $1.13 \text{ W/m}^2\text{K}$. The density of walls was changed to produce 4 different thermal inertia values ranging from 0.05 to 4.

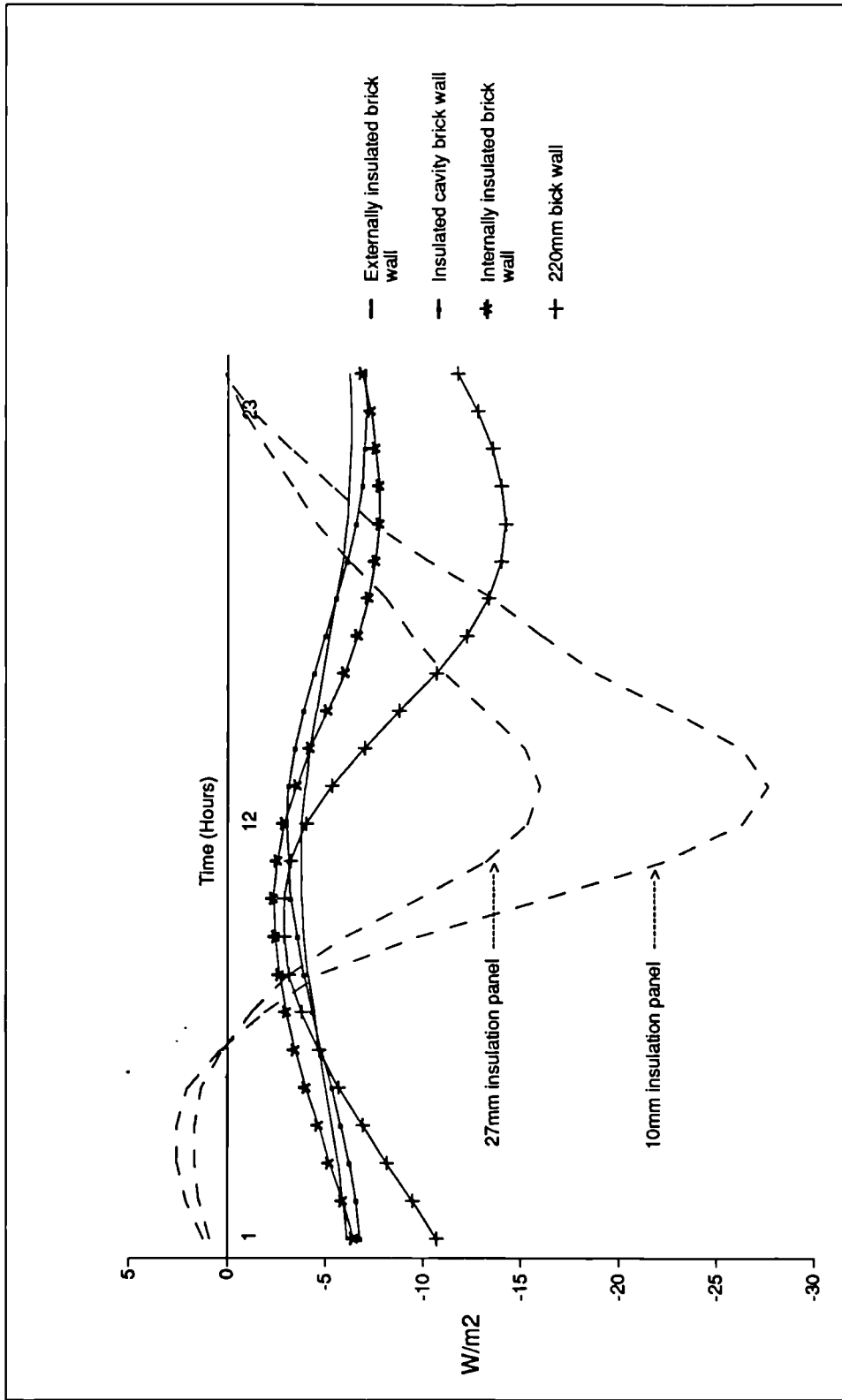

Figure 4.9 Heat flux per square metre at the inside surface of walls

Table 4.1 Thermal performance of different test specimens - summary of results

Test specimens	U - Value W/m ² K	Heat capacity Kj/m ² K	Time (lag) hour	Maximum external surface temp. °C	Maximum internal surface temp. °C	Minimum external surface temp. °C	Minimum internal surface temp. °C	Maximum heat flux W/m ²	Amplitude reduction*	Total inward heat flux (cooling loads) W	Total outward heat flux (heating loads) W	Total plant loads cooling + heating W
10 mm Insulation Panel	2.26	0.120	0 ^{***}	39.4	32.2	19.6	20.3	-27.67	N/A	-2106	99	2205
220mm Brick Wall	2.26	299.2	6	36.8	28.2	21.2	23.8	-14.22	0.51	-1827	0	1827
27mm Insulation Panel	1.13	0.324	0 ^{***}	40.0	28.8	19.5	20.8	-16.00	N/A	-1248	66	1314
Externally Insulated Brick Wall	1.13	299.4 ^{**}	9	39.5	25.3	20.0	24.2	-6.33	0.40	-1098	0	1098
Internally Insulated Brick Wall	1.13	299.4 ^{**}	6	37.0	25.9	21.4	23.6	-7.78	0.49	-1109	0	1109
Insulated Cavity Brick wall	1.13	299.4 ^{**}	9	37.3	25.6	20.9	23.9	-7.11	0.44	-1104	0	1104

* Amplitude reduction = (Maximum heat flux at the internal surface of the masonry)/

(Maximum heat flux at the internal surface of the insulation panel having the same U-value)

** The sum of the heat capacities of the brickwork and the insulation layers.

*** In fact there will be a positive time lag but it is so small that it can be neglected.

The thermal inertia index [4] is a dimensionless quantity obtained by the following equation;

$$\gamma = \left(\frac{\pi L^2 pc \omega}{2 \lambda} \right)^{0.5} \quad (4.5)$$

Where,

p = mass density, Kg/m³

c = specific heat capacity, J/KgK

λ = thermal conductivity, W/mK

L = wall thickness, m

ω = frequency of time varying driving force, seconds

For a 24 hour cycle, equation 5.5 may be written as;

$$\gamma = \left(\frac{\pi L^2 pc}{86400 \lambda} \right)^{0.5} \quad (4.6)$$

The quantity pc/λ in equations 4.5 and 4.6 is the reciprocal of the thermal diffusivity ($\alpha = \lambda/pc$). The thermal diffusivity is an indication of the speed at which the temperature profile moves through a wall. It has typical units of m²/s.

The results are plotted in figure 4.10. The simulation conditions are the same as those used before. Each line represents the temperature rake through the wall at hourly intervals, ranging from 1 to 24 hours. For the wall with small gamma of 0.05, temperature plots are straight lines. As thermal inertia becomes more significant, the temperature plots depart from straight lines.

Result-set 1Z 1 Period from Day 21 Month 7 Hour 1
 (STS Temp) to Day 21 Month 7 Hour 24
 (OTS Temp) Deg.C

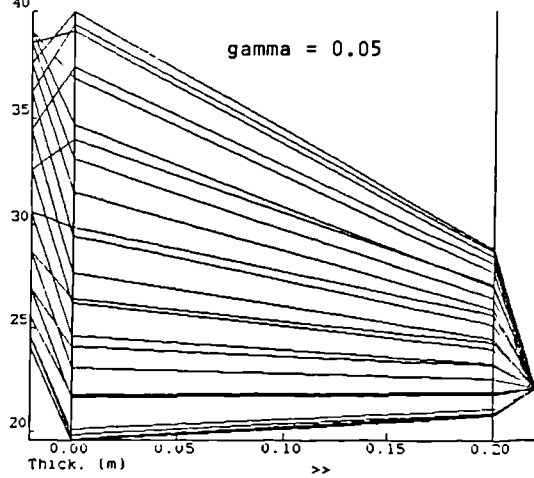

Result-set 1Z 1 Period from Day 21 Month 7 Hour 1
 (STS Temp) to Day 21 Month 7 Hour 24
 (OTS Temp) Deg.C

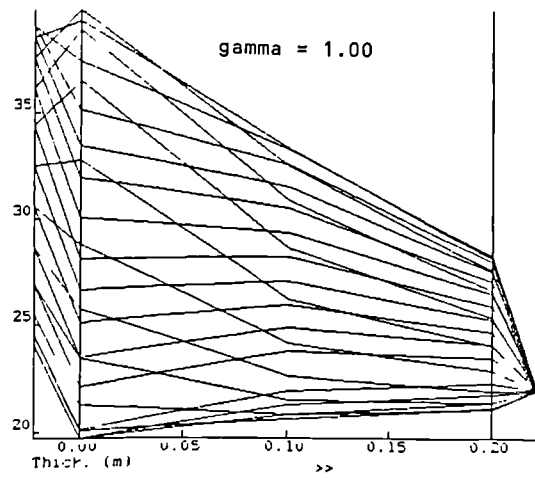

Result-set 1Z 1 Period from Day 21 Month 7 Hour 1
 (STS Temp) to Day 21 Month 7 Hour 24
 (OTS Temp) Deg.C

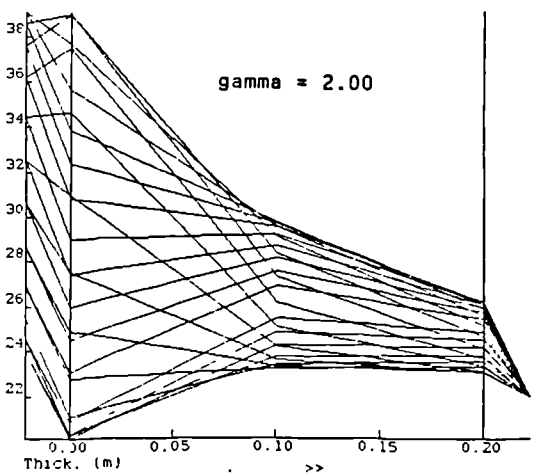

Result-set 1Z 1 Period from Day 21 Month 7 Hour 1
 (STS Temp) to Day 21 Month 7 Hour 24
 (OTS Temp) Deg.C

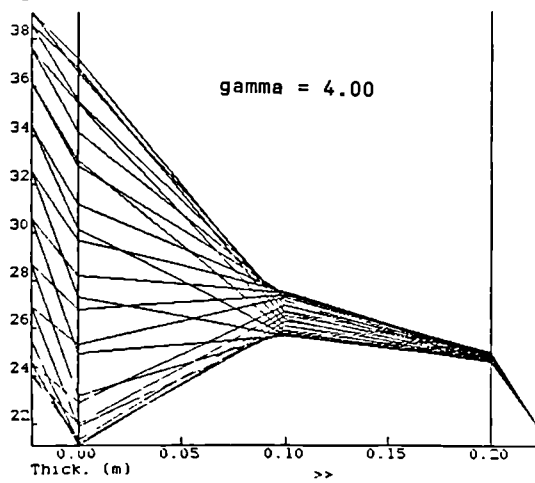

Figure 4.10 Wall temperature rakes.

The external surfaces of walls (on the left) experience the outdoor conditions on the 21st of July. The internal surfaces (on the right) experience a constant air temperature of 22 °C. The inside surface temperature fluctuations reduce as (γ) increases.

Temperature rakes indicate that the intra-construction temperature distribution becomes narrow as the energy flows through the element. The range diminishes more significantly in structures having higher values for γ indicating that the inner parts of the structure and its innermost surface, i.e. the internal surface, undergo smaller variations in temperature.

Table 4.2 lists the maximum and minimum internal surface temperatures of the walls whose thermal behaviour's were shown in Figure 4.10. The range is simply the difference between the maximum and minimum surface temperatures. The internal air temperature is kept constant at 22 °C. The surface temperature range of the specimen having a thermal inertia index of 0.05 is nearly 16 times wider than the corresponding range for the specimen having a thermal inertia index of 4.

Table 4.2 Variations in internal surface and air temperatures(°C)

Thermal inertia index (γ)		0.05	1	2	4
Surface temperature	Max.	28.8	28.3	26.2	25.0
	Min.	20.7	21.1	23.3	24.5
	Range	8.1	7.2	2.9	0.5
Air temperature (fixed)		22	22	22	22

In free floated buildings, the internal air temperature is influenced by the flow of energy through different flowpaths. To analyse the effect of the flow of energy through the previous elements on the air temperature of the test box under free-floating conditions, further simulation runs were performed for cases when the plant is switched off. The intra-construction temperature distributions are depicted in figure 4.11. Internal air temperatures undergo fluctuations which are proportional to the fluctuations in the surface temperatures. Table 4.3 gives variations in internal surface and air temperatures under free-floating conditions.

Table 4.3 Variations in internal surface and air temperatures(°C) under free-floating conditions

Thermal inertia index (γ)		0.05	1	2	4
Surface temperature	Max.	36.1	33.6	30.4	28.9
	Min.	21.7	23.6	26.7	28.4
	Range	14.4	10.0	3.7	0.5
Air temperature	Max.	34.2	32.5	30.0	28.8
	Min.	23.3	24.6	27.4	28.5
	Range	10.9	7.9	2.6	0.3

Result-set 1Z 1 Period from Day 21 Month 7 Hour 1
(STS Temp) to Day 21 Month 7 Hour 24
(OTS Deg.C)

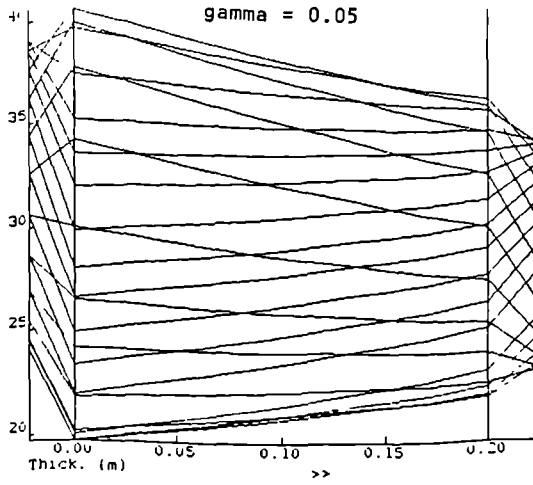

Result-set 1Z 1 Period from Day 21 Month 7 Hour 1
(STS Temp) to Day 21 Month 7 Hour 24
(OTS Deg.C)

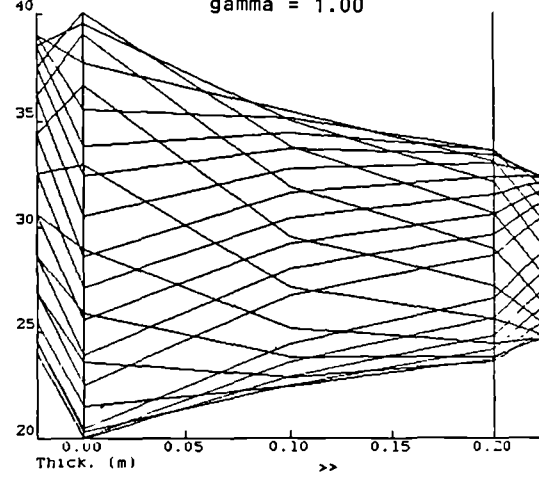

Result-set 1Z 1 Period from Day 21 Month 7 Hour 1
(STS Temp) to Day 21 Month 7 Hour 24
(OTS Deg.C)

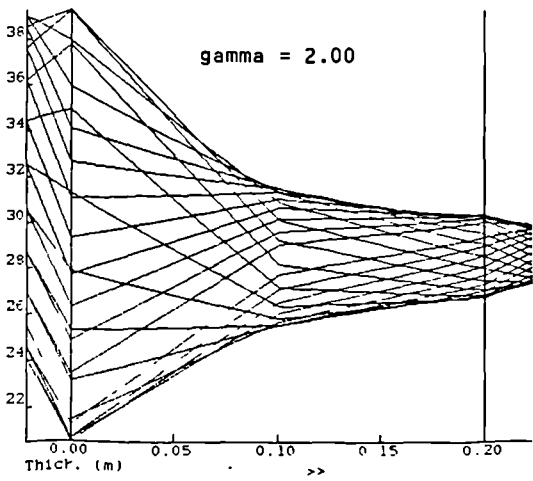

Result-set 1Z 1 Period from Day 21 Month 7 Hour 1
(STS Temp) to Day 21 Month 7 Hour 24
(OTS Deg.C)

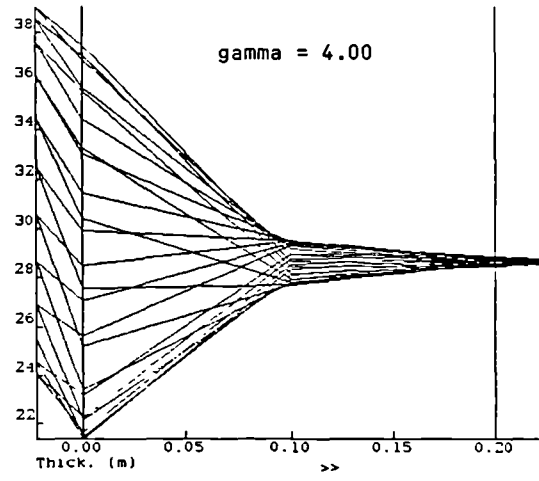
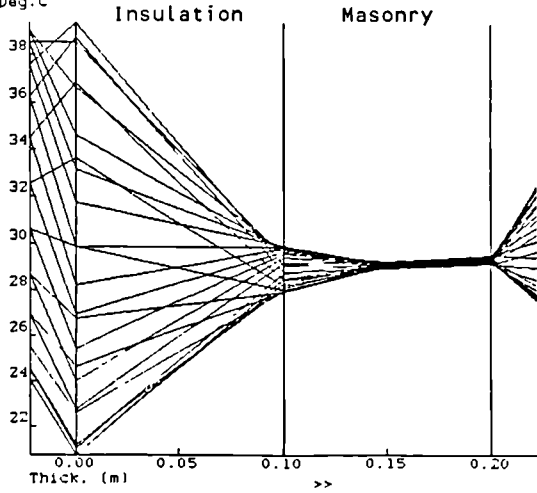

Figure 4.11 Wall temperature rakes.
Comments as figure 4.10 except the inside air is free-floated

From tables 4.2 and 4.3 it should be noticed that the minimum surface temperatures of the thermally light specimens are lower than the corresponding values for the thermally heavy specimens. This is due to the fact that they lose the energy more rapidly (as their thermal diffusivities are higher) compared to thermally heavier specimens. The same pattern may be seen in figures 4.3 to 4.8 where the minimum surface temperatures of insulating panels are lower than those of masonry walls.

To highlight the effect of the relative position of insulation to the masonry on the temperature profiles some simulation results are depicted in figure 4.12. We considered two walls of equal thickness comprising of two layers; insulation and masonry, each 100mm thick. The insulation layer has a thermal inertia value of 0.05 and the masonry a value of 4 respectively. Once the insulation is placed outside the masonry (Case A) and once inside (Case B). The indoor air temperature of the test box is free-floated and an infiltration rate of 1 air change per hour is provided to accentuate swings in its air temperatures. The ability of thermal mass in dampening interior temperature swings by storing excess heat gains is confirmed when it is placed inside. When insulation is inside, the internal surface of the wall experiences higher fluctuations in temperature than if the relative position of two layers was reversed.

Result-set 12 1 Period from Day 21 Month 7 Hour 1
 (STS Temp) to Day 21 Month 7 Hour 24
 (OTS Deg.C)



(A)

Result-set 12 1 Period from Day 21 Month 7 Hour 1
 (STS Temp) to Day 21 Month 7 Hour 24
 (OTS Deg.C)

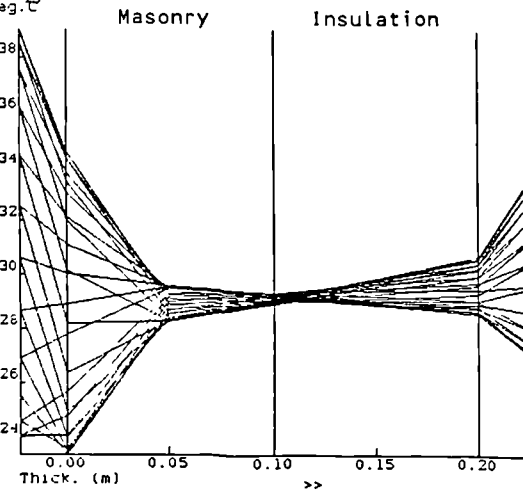

(B)

(C)

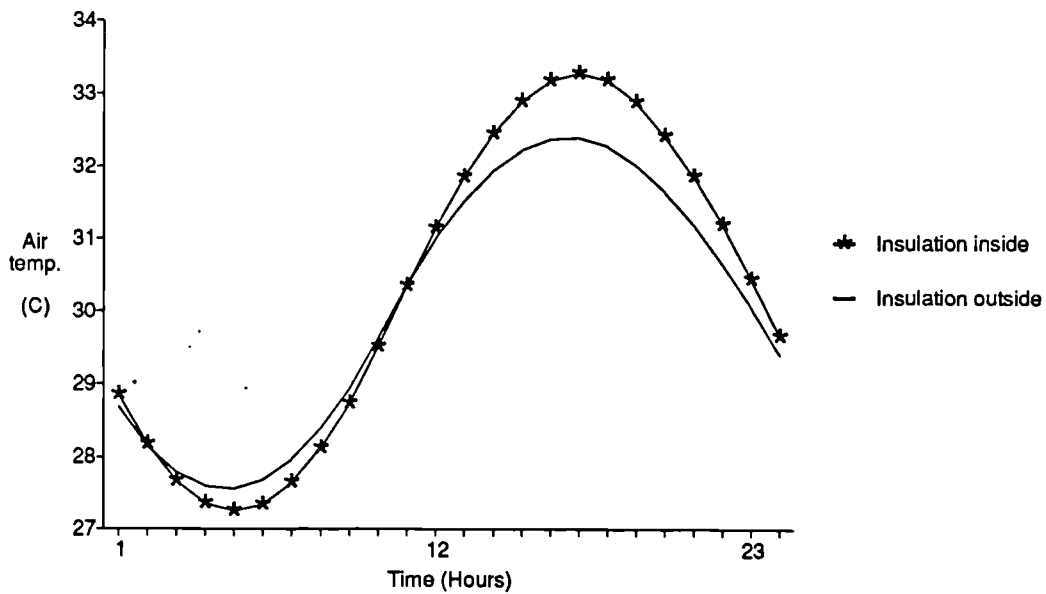

Figure 4.12 Wall temperature rakes (A and B) and inside air temperature (C) as a function of position of insulation. Wall is made of two layers; insulation and masonry of equal thicknesses. Inside air temperature is floating and its temperature is influenced by 1 air change per hour. The external surfaces of walls experience the outdoor conditions on the 21st of July.

4.4 THE EFFECT OF THE MASONRY THICKNESS ON THE HEAT FLOW THROUGH WALLS

The preceding sections confirmed that thermal mass is capable of reducing peak cooling loads as well as the daily energy requirements. To investigate the effect of the level of thermal heat storage capacity of an exterior element on the energy savings, in a series of sensitive simulation runs, the thickness of the masonry, brick, in the test wall was changed to produce different heat storage capacities ranging from 100 to 450 $\text{Kj/m}^2\text{K}$. By changing the thickness of masonry, the insulation thickness was modified to keep the U - value of the wall at a constant value of 1.13 $\text{W/m}^2\text{K}$.

Shown in figure 4.13 are the results for two different days in the cooling season; 21st of July and May. As has been reported by other researchers [9], the figure shows that the thermal mass has an unimportant effect on the energy requirements in the hot spell of the cooling season when a space cooling load exist during each hour of every 24-hour period. The heat flux at the inside surface of the externally insulated wall is almost the same regardless of the masonry thickness on the hot spell of the summer, 21th of July. However, in the case of the internally insulated wall, the heat flux decreases more noticeably as the thermal heat storage capacity of the masonry increases until it approaches a value of 300 $\text{Kj/m}^2\text{K}$. From this point onwards, heat fluxes at the internal surfaces of the two walls are the same.

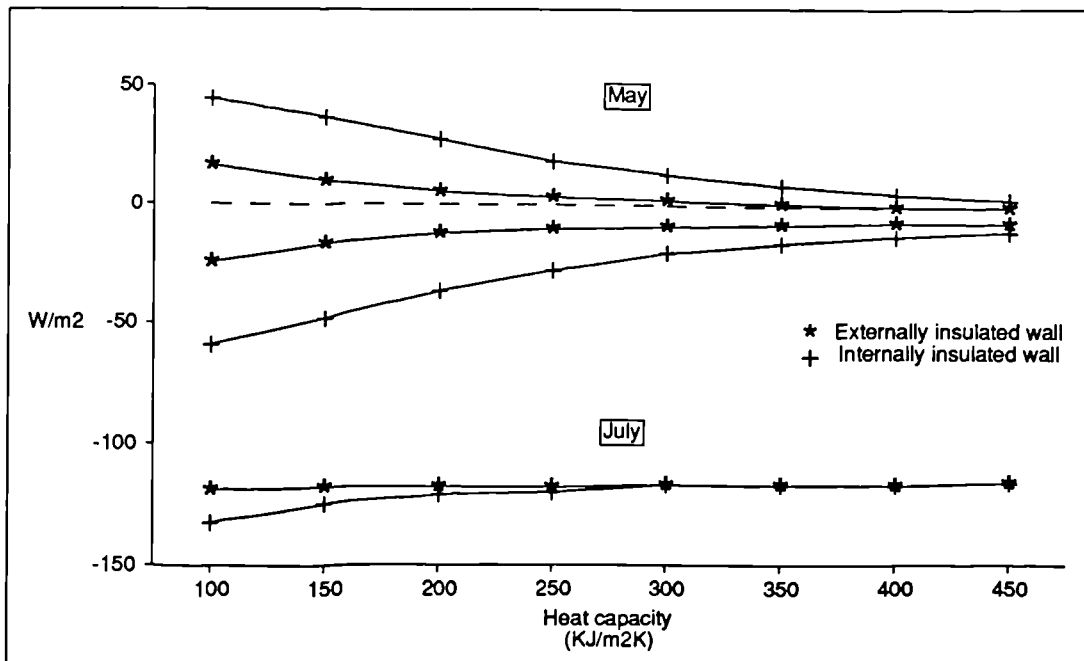

Figure 4.13 Heat flux per square metre at the inside surface of externally and internally insulated brick walls having different thermal heat storage capacities

At the beginning of the cooling season, May, when the climate is milder and the outdoor temperature at night is sufficiently cool to cause the indoor temperature to drop below the indoor set temperature, a significant thermal mass effect may be observed (Figure 4.13).

The effect of thermal mass on energy requirements during different months of the year will be discussed in the following chapter.

4.5 THE EFFECT OF INSULATION THICKNESS ON THE HEAT FLOW THROUGH WALLS

In order to investigate the effect of insulation thickness on the heat flow through walls, layers of insulation having different

thicknesses were applied to the external surface of a brick wall of a thickness of 220mm. Results are tabulated in table 4.4.

The addition of the first layer of insulation of the thickness of 25mm to the uninsulated wall reduces the averaged heat flux at the internal surface of the wall substantially, a reduction of the order of 47%. The averaged heat flux per square metre at the internal surface of the wall is simply calculated by dividing the amount of the total heat removed by the plant during a 24 - hour period from hour 1 to 24 on the 21th of July by the surface area of the wall.

The successive additions of 25mm of insulation (to totals of 50, 75, 100, 125 and 150mm) cause further reductions in the heat flux but with a diminishing effect. The last addition of 25mm insulation (total of 150mm) reduces the heat flux just by 3% compared to the previous thickness of 125mm.

Table 4.4 Percent reduction in heat flux as the result of insulation thickness (21th July)

Insulation thickness (mm)	0.0	25	50	75	100	125	150
U - value (W/m^2K)	2.26	0.93	0.59	0.43	0.34	0.28	0.24
Heat flux (W/m^2)	188.89	100	68.89	53.33	43.33	36.67	31.11
Percent reduction in heat flux	0.0	47	64	72	77	81	84
Difference in percent reduction		47	17	8	5	4	3

4.6 SURFACE CHARACTERISTICS WITH RESPECT TO RADIATION

When solar radiation is incident on a surface, a portion of total irradiation is reflected, a portion may be transmitted and the remainder is absorbed. The absorptance, a , of a surface which is the fraction of the total irradiation absorbed, the reflectance, r , which is defined as the fraction of the irradiation that is reflected from the surface and the transmittance, t , which is the fraction of the incident radiation that is transmitted, describe how the total irradiation, G , is distributed.

When an energy balance is made on the surface receiving irradiation at the rate G , we can write;

$$G = a * G + r * G + t * G \quad (4.7)$$

and therefore;

$$a + r + t = 1 \quad (4.8)$$

When a body is opaque it will not transmit any of the incident radiation; that is;

$$t = 0 \quad (4.9)$$

and for an opaque body we have;

$$a + r = 1 \quad (4.10)$$

Light coloured, smooth and shiny surfaces tend to have a high

reflectance. On the other hand dark coloured surfaces tend to have a high absorptance. For example, a good mirror approaches a reflectivity of 1, and a perfect black body absorbs all of the irradiation and therefore has an absorptance equal to unity and a reflectance equal to zero.

Another important characteristic of real surfaces is their relative power to emit radiant energy. At a given wavelength, the maximum amount of radiation which can be emitted will be that from a black body, i.e. the emissivity of a perfect black body is equal to unity. The emissivity of a non black body is the ratio of the energy emitted by that body to the energy emitted by a black body at the same wavelength. One should note that the value of the coefficient of emittance is the same as for absorptance for the same wavelengths of radiation, but may differ for different wavelengths.

At ordinary temperatures, the radiation emitted by surfaces is in the far infra-red range of the spectrum (peak intensity about 10 microns). At this wavelength, the colour of the surface does not indicate the behaviour of the surface with respect to radiation emitted from the surface. Therefore, most ordinary building materials have similar values of emissivities of the order of about 0.9 at normal temperatures regardless of their colour. However, surfaces covered with high polished metallic materials may have very low emissivities. For example, values of 0.05 and 0.25 have been suggested for bright aluminium foil and galvanised steel respectively[18].

4.7 THE EFFECT ON HEAT FLOW OF COLOUR, ORIENTATION, AND THERMAL RESISTANCE OF THE FABRIC

The fraction of incident solar energy reflected by the exterior surfaces of a structure can significantly affect the overall heat gain or loss of the structure. This is particularly true for regions that receive an abundance of solar radiation as occurs in hot dry climates.

The importance of the surface reflectivity of an element depends on the intensity of radiation it receives. The intensity of radiation received per unit area of the surface may be determined as follows;

$$I = I_n * \cos B \quad (\text{W/m}^2) \quad (4.11)$$

Where;

I_n = the intensity of radiation on a surface normal to radiation, W/m^2
 B = the angle of incidence for the surface in question, Degrees (see Chapter 7).

At any given location, therefore, the intensity of radiation on a surface may vary with the position of the surface, i.e. with its orientation and tilt. The intensity of radiation on a surface also varies with the time of day and year as the relative position of the sun to the earth changes. For example, in summer when the sun has a high altitude, one can assume that the roof has the most critical role in the heat gain as the values of $\cos B$ in equation 4.11 are high and consequently high intensities of solar radiation are

received by the roof. In winter, when the sun is low in the sky, surfaces facing the equator are more important.

Figures 4.14 and 4.15 depict the external surface temperatures of vertical walls facing four cardinal orientations together with those of a flat roof in the months of July and January respectively. All surfaces are of the same construction, 220mm brickwork, having the same external surface characteristics with respect to radiation ($a = 0.5$). Each surface was the only external surface of the test box during a simulation run.

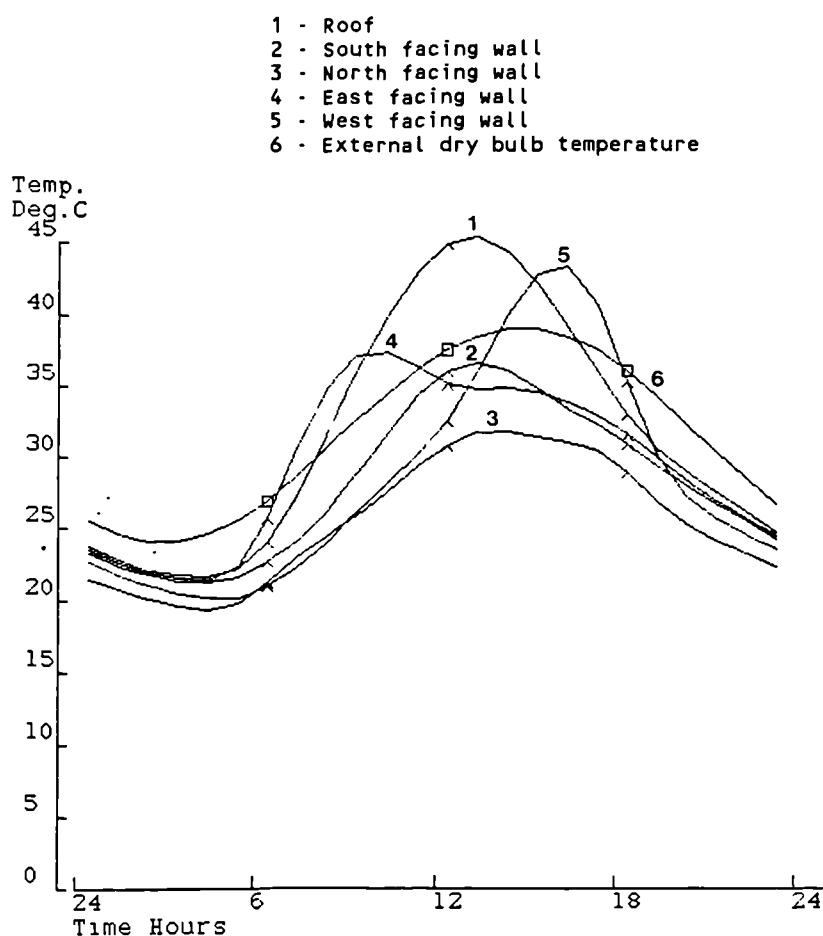

Figure 4.14 The effect of orientation on external surface temperatures (July)

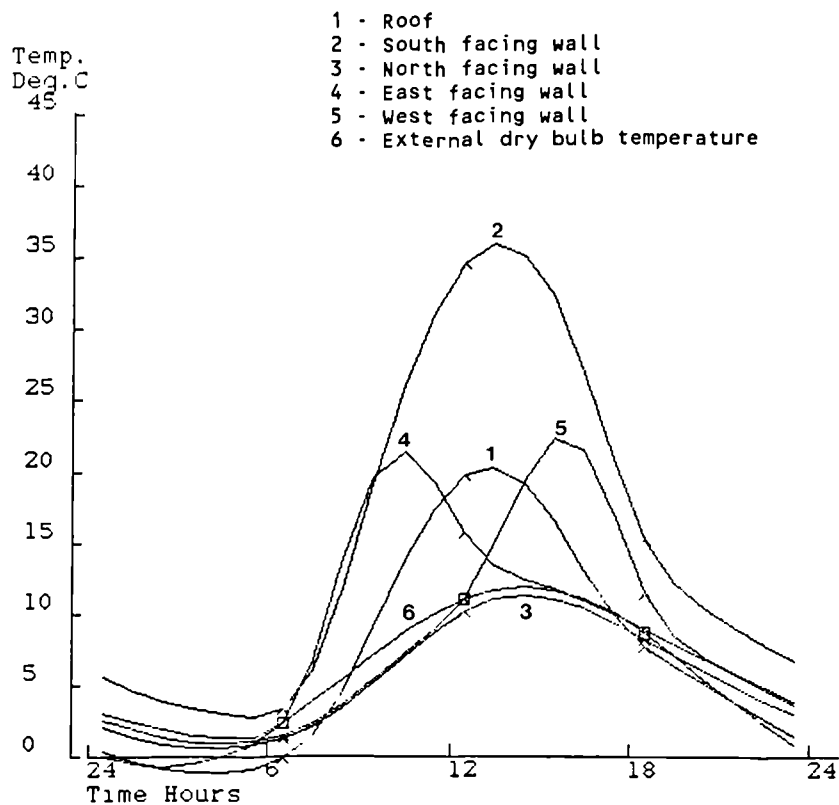

Figure 4.15 The effect of orientation on external surface temperatures (January)

As is shown in figure 4.14, the roof experiences the highest surface temperature due to the extensive solar radiation it receives in July. On the other hand in January it is the south facing wall which has the highest surface temperature compared with other surfaces.

To determine the effect of colour and thermal resistance of building elements on their internal surface temperatures, Givoni [18] measured the surface temperatures of lightweight horizontal panels made of 20mm asbestos-cement in the mid summer at the local latitude of 32° N. The external surfaces of the panels were painted in

black ($a = 0.82$), grey ($a = 0.62$) and white ($a = 0.11$) respectively. The maximum internal surface temperature was reduced by 15°C when moving from black to grey and by a further 22°C when moving from grey to white for uninsulated panels. When insulation was added to the under-side of panels, the maximum internal surface temperatures of panels were reduced as the result. The reductions were more significant for panels of darker colours. In all cases there was a diminishing effect of the colour of the external surfaces of panels on their internal surface temperatures as the thickness of the insulation increased indicating that the modification of surface characteristics as a conservation measure may be more effective in buildings with little or no insulation than in buildings with high insulation levels.

Surfaces of very light colours may not only be visually uncomfortable due to the high levels of glare they may produce, but are difficult to maintain because of dirt, discoloration, dust deposit and other environmental factors. Theoretically speaking, reflectivity can assume any value between 0.0 to 1.0. For practical purposes, we assumed a solar absorptivity of 0.5 to represent surfaces of common available building materials in relatively light colours, i.e. off - white, cream, buff or other bright coloured brick, concrete blocks, renders, stones or light colour painted surfaces. On the other hand, a value of 0.85 was considered for dark colour surfaces such as asphalt, dark coloured painted, coated or shingled surfaces. Throughout this study whenever it is not specifically defined, surfaces are of light colours having a solar absorptivity of 0.5.

It should be recalled that the internal surface temperatures measured by Givoni [18] are for light weight materials. In the case of conventional structures, the increased thermal heat storage capacity will reduce the amplitude of the surface temperature swing. Figure 4.16 shows the internal surface temperatures of uninsulated and insulated 150mm thick concrete slabs. (the thermal heat storage capacity of the concrete slab is $317.2 \text{ KJ/m}^2\text{K}$). The maximum internal surface temperature has been reduced by 7°C when changing the colour of uninsulated slab from dark to light.

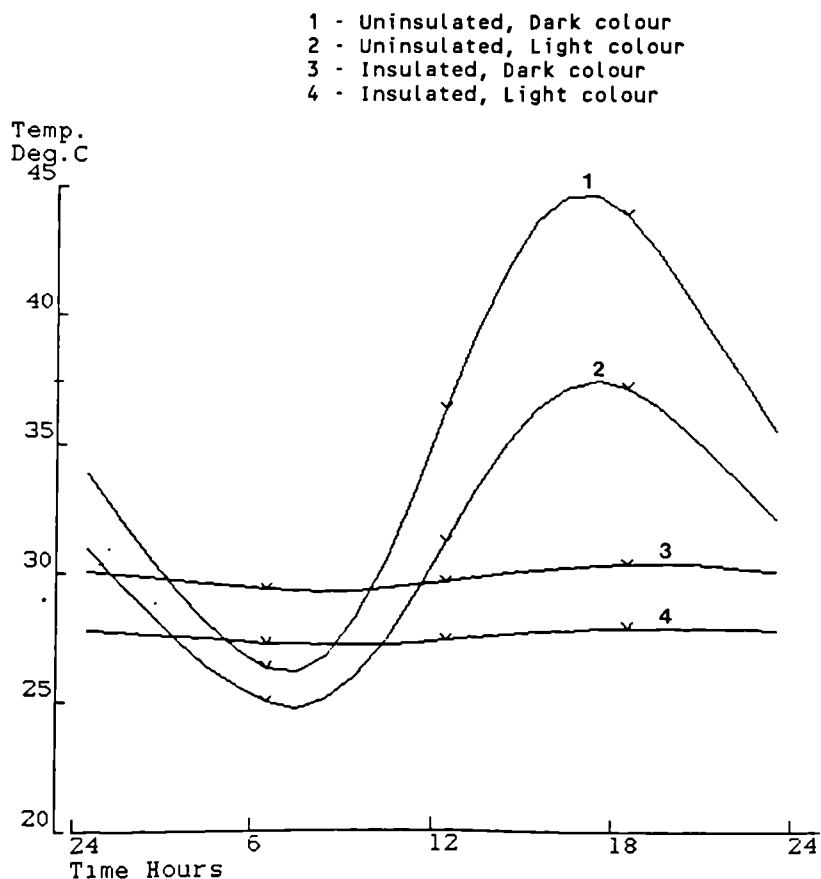

Figure 4.16 The internal surface temperatures of insulated and uninsulated horizontal concrete slabs (July)

As the result of the addition of 50mm insulation to the upper-side of slabs, i.e. as in conventional warm roofs (see Chapter 6), the maximum internal surface temperatures of slabs were reduced significantly (Figure 4.16). As can be seen, the surface characteristic modification as a means to reduce the surface temperature is more effective in uninsulated slabs than in insulated slabs.

Changes in surface temperatures of 220mm brickwork walls were also calculated as the result of modifications in their surface characteristics. Results for south facing walls on the 21 of July are depicted in figures 4.17 and 4.18.

The external surface temperatures of walls increase as their surface solar absorptivity increases (Figure 4.17). The application of 50mm insulation to the external surface of the brickwork causes higher external surface temperatures compared with uninsulated walls of the same colour as the insulation layer warms up quickly due to its low thermal heat storage capacity on one hand and its high resistance to the heat flow on the other hand. As in the case for horizontal slabs, the internal surface temperatures of walls reduce as the surface solar absorptivity and/or U - value of the wall reduce (Figure 4.18).

It can be assumed that if solar absorptivity of a building surface is lowered, the energy required for cooling will most likely reduce as the heat transfer through the surface should be smaller following the reduction in surface temperature during sunlit hours. On the

other hand, as the high external surface temperatures tend to impede heat loss through structures during the heating season, a reduced surface absorptivity may result in an increase in the heating energy requirement of the building due to low surface temperatures.

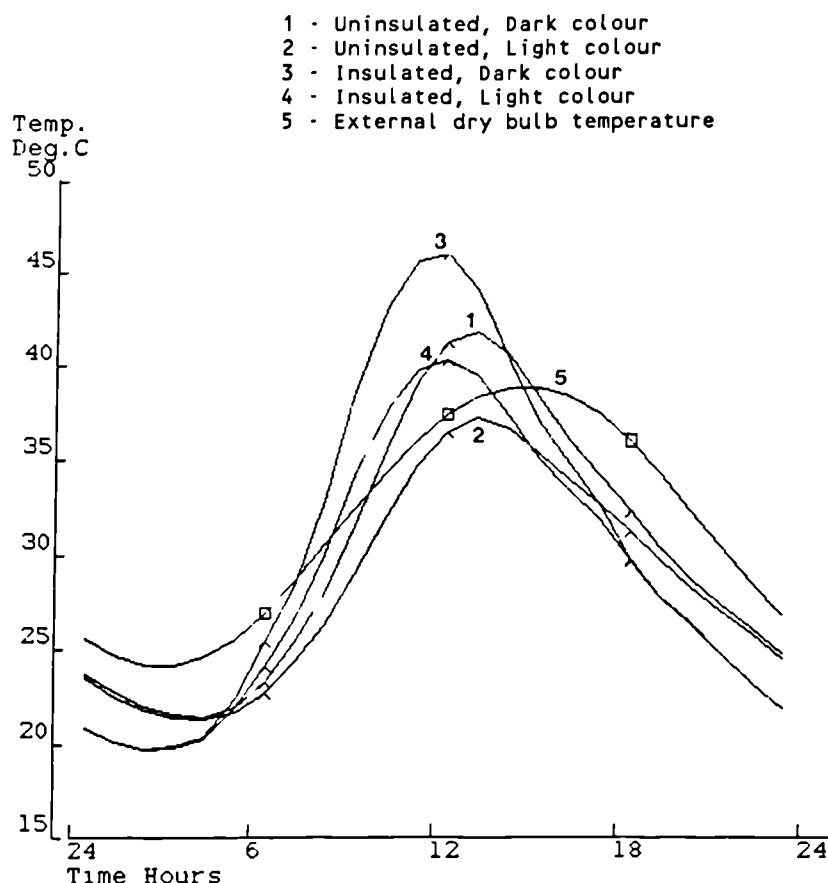

Figure 4.17 External surface temperatures of insulated and uninsulated south facing brick walls (July)

In single-load dominated climates, i.e. heating or cooling only, the solar absorptivity of the envelope should be high in heating dominant, and low in cooling dominant. In climates with both heating and cooling requirements, the effect of the colour of the buildings' envelopes is more complicated and its effectiveness as a

conservation strategy may become less obvious. This is discussed in detail in Chapter 6.

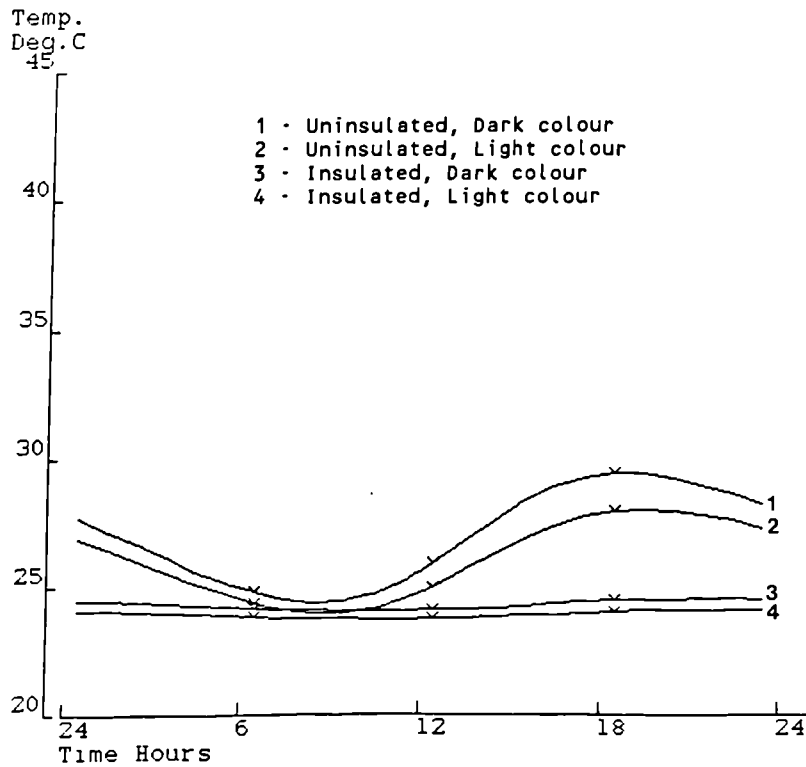

Figure 4.18 Internal surface temperatures of insulated and uninsulated south facing brick walls (July)

It is a well known fact that in hot dry climates where the main concern both from the point of view of thermal comfort and energy cost is the cooling period, buildings should be of light colours to reduce heat gains through the fabric. The potential of low surface absorptivities on improving the overall thermal performance of buildings in arid zones is well understood so that light coloured facades are among characteristics of the architecture of these regions.

4.8 REFERENCES

- [1] Wilcox, B. et al *The effects of thermal mass in exterior walls on heating and cooling loads in commercial buildings.* Proceedings of the ASHRAE/DOE/BTECC conference on the thermal performance of the exterior envelopes of buildings III. December 1985, Florida.
- [2] Childs, K. W. *The influence of thermal mass on building energy usage.* Proceedings of the building thermal mass seminar. June 1982, Knoxville, Tennessee, USA.
- [3] Lewis, D., Michal, C. and Pietz, P. *Design of residential building utilising natural thermal storage.* Division of buildings and community systems, U.S Department of Energy, June 1979.
- [4] Jaeger, s. and Arumi, F. *A comparison of thermal requirements of buildings.* Energy and Buildings, Vol.1, 1977.
- [5] Catani, M.J. and Goodwin, S. E. *Heavy building envelopes and dynamic thermal response.* American Concrete Institute Journal, Vol. 73(2), February 1973.
- [6] Murphy, W.E. *The influence of the thermal capacity of a building on its energy consumption.* Proceedings of the 2nd international CIB symposium on energy conservation in the built environment. Copenhagen, 1979.
- [7] Arumi, F. N. *Thermal inertia in architectural walls.* National Concrete Masonry Association, USA, 1977.
- [8] Dexter, M. E. *Including mass and insulation in building walls.* ASHRAE Journal, March 1980.
- [9] Burch, D.M., Malcolm, S. A. and Davis, K. C. *The effect of wall mass on the summer space cooling of six test buildings.* ASHRAE Transactions, Vol.90, part 2B, 1984.
- [10] Burch, D. M., Krintz, D. F. and Spain, R. S. *The effect of wall mass on winter heating loads and indoor comfort - an experimental study.* ASHRAE Transactions, Vol. 90, part 1B, 1984.
- [11] Byrne, S. J. and Ritschard, R. L. *A parametric analysis of thermal mass in residential buildings.* Proceedings of the ASHRAE/DOE/BTECC conference on the thermal performance of the exterior envelopes of buildings III, Florida, USA, December 1985.
- [12] Goodwin, S. E. and Catani, M. J. *The effect of mass on heating and cooling and on insulation requirements of buildings in different climates.* ASHRAE Transactions, Vol. 85, Part 1, 1979.
- [13] CIBSE Guide, Section A3; Thermal properties of building structures. 1980.

[14] Alamdari, F. and Hammond, G.P. *Improved data correlation for buoyancy-driven convection in rooms*. BSER & T, Vol. 4, No.3, 1983.

[15] *Report on heat transfer at internal building surfaces*. Department of Energy, ETSU, UK. S 1193-p1, 1990.

[16] Mc Adams, W.H. *Heat transmission*. Mc Graw-Hill, 1954.

[17] Clarke, J.A. *Energy simulation in building design*. Adam Hilger Ltd. 1985.

[18] Givoni, B. *Man, climate and architecture*. Elsevier publishing Company, 1969.

Chapter 5

THE EFFECT OF MASS ON COMFORT AND ENERGY REQUIREMENTS

5.1 Introduction

5.2 Development of the computer models

5.3 Selected results

5.4 Energy related indicators : Loads

5.5 Environmental indicators : Thermal Comfort

5.6 References

5.1 INTRODUCTION

A premise investigated in the preceding chapter was that the beneficial aspects of the thermal heat storage capacity of the materials of conventional building construction are ultimately due to the fact that they do not heat up or cool down instantaneously. It was demonstrated that this thermal property of materials gives rise to a delay, or a "time lag", and attenuation of the energy loads that the building fabric places on the mechanical equipment.

It was also demonstrated that the effects of thermal mass are unimportant in the hot spell of summer (see Figure 4.13) when the fluctuations in external air temperatures stay above the thermostat set point. In contrast, the effect of mass on reducing plant loads was found to be more appreciable at the beginning of the cooling season, e.g. on a day in May (Figure 4.13) which exhibits a temperature fluctuation between 32 and 17 °C, going both above and below the thermostat set point (22 °C).

In the previous chapter we also analysed how two different walls having the same U-value but different thermal heat storage capacity behave quite differently. The internal surface temperatures of specimens having negligible thermal heat storage capacity, e.g. the insulation panels, followed the external surface temperatures with no distinguishable time lag (Figures 4.3 and 4.5). The internal surface temperature was lowest when the external surface temperature was lowest and it was highest when the external surface temperature was highest.

The case for masonry walls was however, quite different. The thermal heat storage capacity of walls produced a time lag effect. For example, the internal surface temperature of the uninsulated brick wall (Figure 4.4) reduces as its external surface temperature (or the outside air temperature) rises and increases as the outside temperature falls.

The results of sensitive simulations indicated that under the boundary conditions assumed in Chapter 4, the energy flow across masonry walls puts considerably lower loads on the environmental control equipment than the energy flow through light weight panels.

The previous chapter gives an insight to the effect of thermal performance of opaque elements under simplified conditions assuming for example;

- internal heat generation = 0
- amount of glass = none
- ventilation/infiltration = 0
- inter zone coupling = none
- wall orientation = south

The overall thermal performance of a building however, is the result of a series of thermal interactions between various flowpaths commonly encountered inside and outside buildings, for example; metabolic heat of the occupants, transparent surface solar radiation, infiltration/ventilation, and so on.

The objective of this chapter is to analyse the influence of thermal mass on the energy requirements of the reference house and the

thermal comfort of its occupants under representative control strategies.

5.2 DEVELOPMENT OF THE COMPUTER MODELS

As stated in the previous chapter, the influence of the thermal heat storage capacity of building materials on the environmental performance of buildings can be conveniently examined by comparing the performance of buildings having total building fabric of similar thermal resistance with different thermal heat storage capacity. It is a common practice to take this as a criterion, both in field measurements and computer simulations [1 - 10], when analysing the effect of thermal mass on heating and cooling energy requirements of buildings.

In the preceding chapter it was also highlighted that the position of the insulation layer may have a profound effect on the energy flow through the walls. An enclosure surrounded by internally insulated masonry components behaves similar to light weight structures because the available mass in its fabric is thermally isolated from the interior.

While keeping the thermal resistance of the external shell of the reference house constant, the position of the insulation was changed to expose different amounts of mass to adjacent zones.

The material selected for the walls is masonry, specifically, brick.

Bricks are found to be the most available, buildable, and cost-effective form of thermal heat storage for immediate use in the housing stock. The popular acceptability of brick walls, compared to the other masonry options, argues for their use in a house for the general market. Bricks are available in various colours, however, light colour bricks should be used on the exterior to reduce the radiative heat gain at the surface of the wall.

Given brick as a building material, optional thickness for a wall comprised of standard units (220 * 105 * 55mm) are 105mm (one width of brick), 220mm (2 width of brick) or 330 mm (three width of brick). The cost penalty (given the labour intensity of brick laying) is such that the optimum thickness for external brick walls is 220mm. Since the final version of the "building energy model" (Figure 1.4, Chapter 1) adopted as the framework for this research implies that; "design solutions should be obtained economically through the architectural application of construction consistent with common practice", the thickness of the masonry in the external walls was taken to be 220 mm.

This thickness was chosen because it is the most common thickness (2 width of brick) used in practice. In addition, it provides a suitable thermal performance. Simulation results in Chapter 4 (see figure 4.13) showed that the effect of the thermal heat storage capacity of the wall on the energy requirements diminishes as the thickness of the masonry increases. The thermal heat storage capacity of a 220mm brick wall is $299.2 \text{ KJ/m}^2\text{K}$ (thermal properties of brick are: density = 1700 Kg/m^3 , specific heat = 800 J/Kg K). For

capacities higher than this there is no appreciable change in performance.

Concrete floors and roofs which are widely used in the design of contemporary buildings were assumed. By changing the position of the insulation layers in the external walls, roofs and floors, and considering internal partitions built with different materials while having identical thermal resistance, three computer models were developed which from the thermal response point of view may be considered to cover the spectrum from nominally thermally heavyweight to nominally thermally lightweight construction. Construction details of the models are given in figure 5.1.

It is important to note that the assumed values for input such as thermostat set-points, air changes, surface characteristics with respect to radiation, internal gains and occupancy remained identical for all three models.

5.3 SELECTED RESULTS

To investigate the effects of thermal mass and its location on the thermal performance of buildings, a group of simulation scenarios was run. Heating and cooling requirements (energy related indicators) and the thermal comfort of the occupants (an environmental indicator) have been used in evaluating the scenarios.

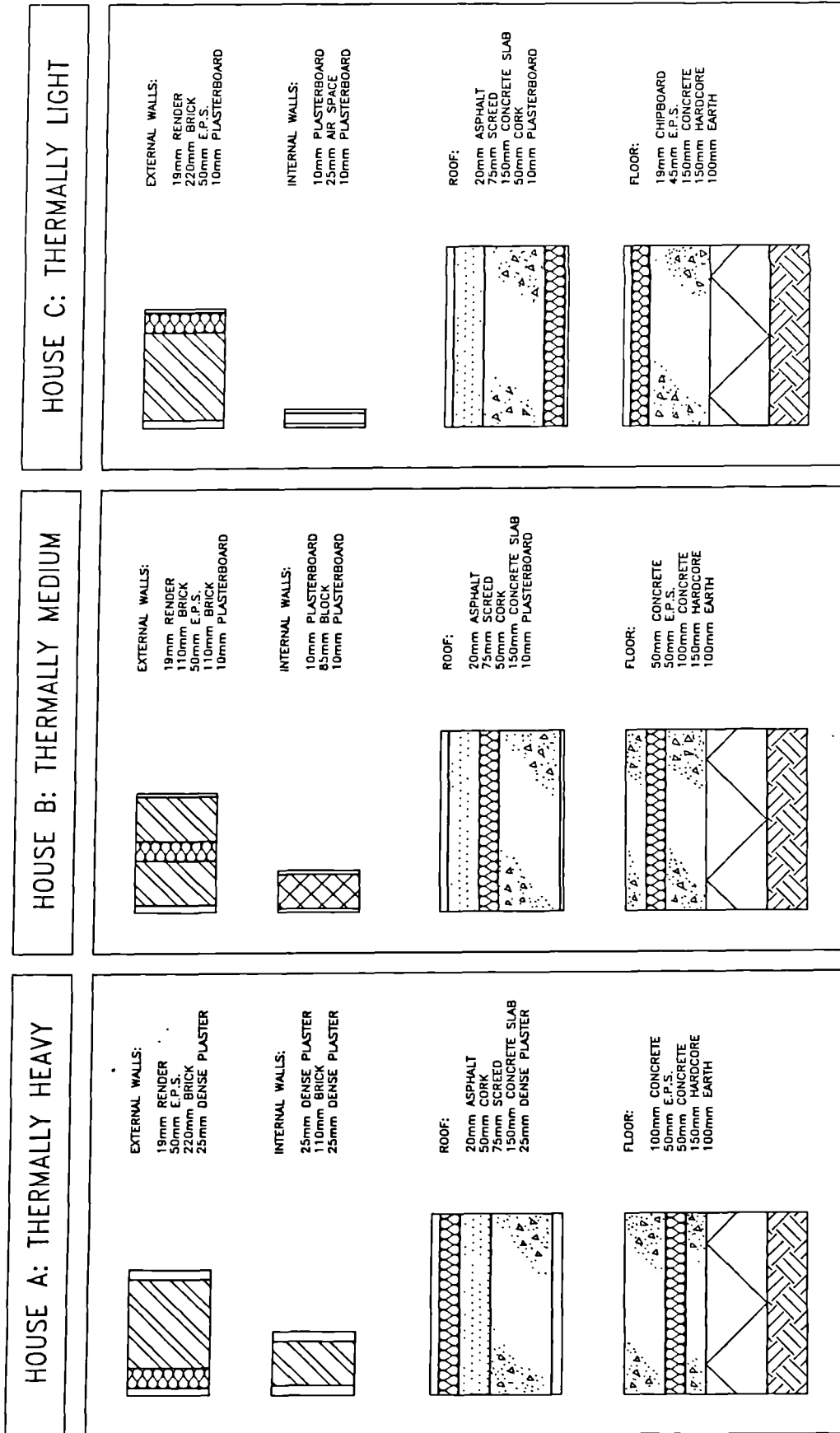

Figure 5.1 Construction details of models

5.4 ENERGY RELATED INDICATORS : LOADS

A premise investigated in the previous chapter was that the effectiveness of thermal mass varies with time, from month to month. To analyse this further, calculated monthly heating and cooling requirements of models are presented in figures 5.2 and 5.3. The former illustrates monthly loads under continuous control strategies (see Table 1.1, Chapter 1). The latter depicts the monthly loads under the intermittent control strategies (see Table 1.2, Chapter 1).

At any time the need for heat in building is met by one or more of the following three sources:

- *solar radiation entering rooms through windows*
- *the heat generated by domestic appliances, lighting and from the metabolic heat of the occupants (collectively may be termed as casual gains)*
- *the output from the heating system*

The first two of the above sources may be classified as "nonsynchronous" energy sources. The term refers to any thermal energy source whose availability and magnitude with respect to a building's thermal load is a function of time, chance and is not subject (as are typical fuel based energies) to precise load-matching with control systems. Among climatic factors, solar energy is the most prominent example of such energy sources.

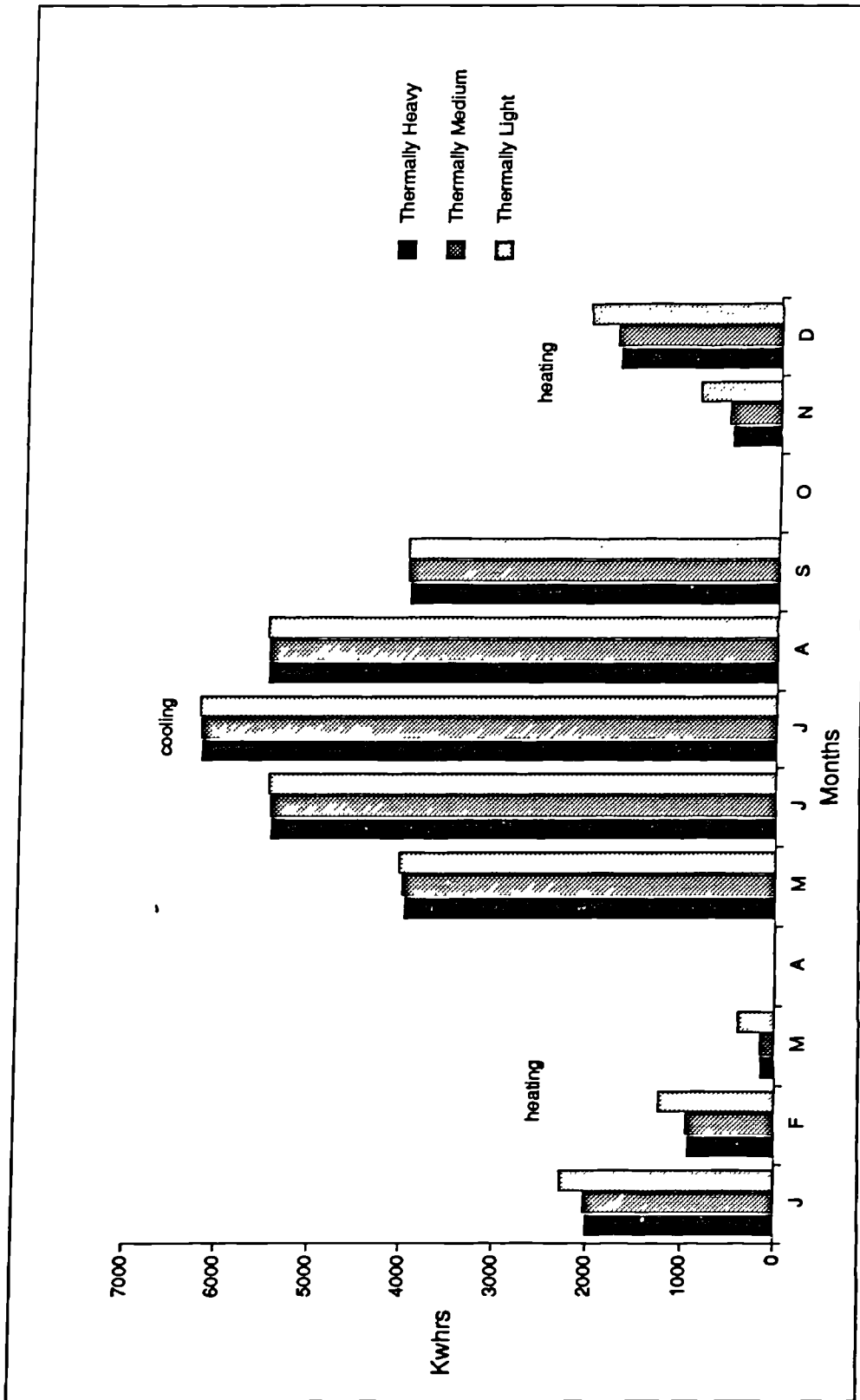

Figure 5.2 Monthly energy requirements of models under continuous operation

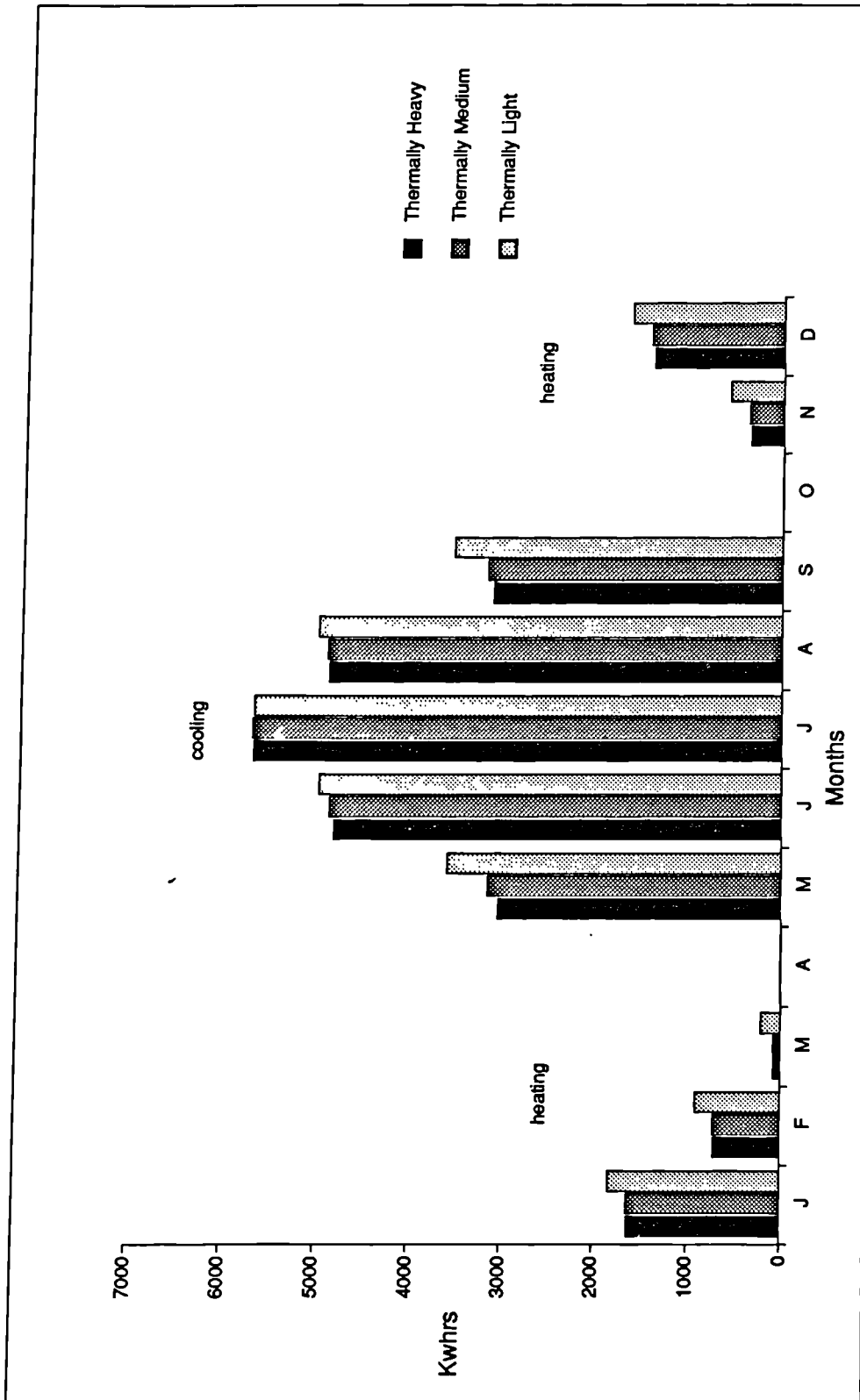

Figure 5.3 Monthly energy requirements of models under intermittent operation

From the heat supplied by nonsynchronous energy sources one part may go toward displacing heating fuel (subjected to heating controls), and the remainder may contribute to higher room temperatures. The potential of thermal mass in reducing overheating risks will be discussed later in this chapter.

In figures 5.2 and 5.3, heating loads are the amount of energy supplied by the plant (subject to heating controls) to prevent the room air temperatures falling below acceptable levels (see thermostat set points in Tables 1.1 and 1.2, Chapter 1). Similarly, cooling loads are the amount of energy extracted by the plant (subject to cooling control) to prevent the room air temperatures exceed the thermostat set point.

During the intermediate heating, when it is sufficiently warm during the day for the heating plant not to operate as the energy supplied by nonsynchronous sources, e.g. the window solar and casual heat gains are enough to maintain the acceptable temperatures, the efficiency of thermal mass in reducing the auxiliary energy demand (supplied by the plant) is greater. For example, the heating requirement of the thermally heavy structure under continuous heating regime is smaller than that of the thermally light model by 58% in March. The corresponding percentage in the month of January, the cold spell of the winter, is only 12%.

As explained in Chapter 4, thermal mass modifies the energy flow patterns (as produced by the nonsynchronous sources). Since thermal mass does not influence the average or total energy available, it is

only beneficial when the modified energy flow pattern is itself of value. Generally speaking, thermal mass functions effectively with time-varying nonsynchronous energy sources, for example at climates or seasons in which the diurnal temperature swings to either side of the heating and cooling thermostat set points [1,2,11 and 12] to allow strategic use of the daily swings in outdoor temperature.

In mid winter, when the diurnal temperature stays below the heating thermostat set point, the energy flow through the fabric approaches a constant pattern as the temperature difference between inside and outside becomes larger. Under these conditions, the effect of thermal mass on the energy requirements of buildings diminishes and the thermal resistance of the fabric becomes the dominant factor in controlling heat flow through the fabric.

Figure 5.2 depicting energy requirements of models under continuous strategy, indicates that thermal mass has little effect on monthly cooling loads of models. As explained earlier, one may expect that the thermal heat storage capacity of the building fabric is effective when there are considerable daily swings in outdoor temperature for example, at the beginning or at the end of the cooling season when the external air temperatures fall below the thermostat set points at night. It seems that the night-time temperature is never low enough even at the beginning and the end of the season to cool the exterior walls sufficiently to produce significant calculable economic benefit.

Under the intermittent cooling operation, the use of outdoor

temperature swings has been improved. The "cold" of the night has been stored more efficiently in the greater thermal heat storage capacity of the thermally heavy model, as high volumes of nocturnal ambient air (20 ac/h) have been introduced into the interior of the models.

The efficiency of the nocturnal ventilation cooling of the structure is greater in the beginning and the end of the season, e.g. in May and September when the climate is milder and night time air temperatures are low enough to allow the mass to function more efficiently. As the weather gets warmer the effectiveness of ventilation cooling diminishes so that all models require almost the same amount of energy in the hot spell of the season, the month of July.

The zoning of the reference house has been arranged in such a way as to provide useful information through computer simulations regarding the effect of orientation on the thermal performance of different zones.

As explained in Chapters 2 and 4, the amount of solar radiation falling on surfaces depends on the tilt and orientation of the surface and the time of the day and year. At latitude 32° N, a north facing wall sees the sun for short spells and only in the summer (see the solar chart in Figure 7.2, Chapter 7). At all other time the radiation on north facing walls consists of the diffuse and ground reflected components only. A south facing wall is potentially in view of the sun from sunrise to sunset through the

autumn and winter and for much of the day during spring. The exposure of a south facing wall to sun however, reduces in summer as it for example, may receive direct radiation from about 9.0 to 15.0 hours in mid June. Surfaces facing east and west are somewhere in between as they see the sun for half of the day.

At any time, the intensity of the solar radiation absorbed on a surface is dependent on the angle between the sun's rays and the line perpendicular to the surface, i.e. the angle of incidence. The absorbed radiation may cause the surface temperature of the element to rise above that of the ambient air temperature (see Figures 4.14 and 4.15, Chapter 4).

View of the sun by the glazing is even more important as the glazing may allow most of the incoming solar radiation to be transmitted instantaneously through it. The transmitted radiation through the glazing will be absorbed by the surfaces and objects in the room. The absorbed energy will be released into the room as heat and increase the room air temperature.

The contribution of orientation as an aspect of energy efficient design largely depends on how glazing is distributed between building facades and the type of glazing that is adopted. This study is restricted to single ordinary glazing as other types of glazing, e.g. special glass or double glazing are not used in the housing industry and consequently are not feasible in the "building energy model" adopted as the framework for this research (see Chapter 1).

Prior to analysing the computer simulation results regarding the effect of orientation on loads, some general points should be recalled.

While glass is highly transparent to solar radiation, it is opaque to radiation of longer wavelength (this phenomenon together with other thermal properties of glass will be discussed in detail in Chapter 7). As with other building elements, the heat loss through glazing is by convective and radiation near the boundary surfaces of the material and by conduction across its thickness. The thermal conductivity of ordinary glass (1.05 W/mK) compares with that of masonry materials for example 0.84 W/mK for brick. However, whilst the common structural thickness of brick gives a moderate thermal resistance (0.26 m²K/W for a 220mm brick leaf), that given by 4mm clear float glass is negligible (0.004 m²K/W).

The other factor which differentiates the thermal performance of glass compared with masonry components, is that masonry components respond to heat flow with a time delay. The heat transfer through glazing is virtually instantaneous. Thermal heat storage capacity of a 4mm clear float glass is about 7.5 KJ/m²K (thermal properties of glass are : density = 2500 Kg/m³, specific heat = 750 J/KgK) compared with 299.2 KJ/m²K of a 220mm brick wall).

The effect of the orientation of glazing may be studied in terms of its energy balance. The energy balance of the glazing is the difference between the rate of heat gains through it (mainly due to the useful heat content of the solar energy it transmits indoors)

and the heat losses it incurs over a given period. The energy balance over a given period provides an indication of whether the glazing helps to reduce or increase the building's energy demand.

The energy balance of glazing has been comprehensively assessed in relative terms in Chapter 7 where the effect of variables such as window area, orientation, the effect of shading devices are investigated. The following paragraphs aim at analysing the effect of the orientation of different zones of the reference house on their loads. One however, should notice that the energy requirement of a zone is to some extent influenced by the inter zone coupling effects, i.e. by the thermal conditions of the adjacent zones.

Figures 5.4 and 5.5 confirm the supposition that the optimal orientation for space heating (in the northern hemisphere) is toward south. The simulation results also reveal that thermal mass can take advantage of nonsynchronous energy sources more effectively. The solar radiated thermally heavy structure delays the energy flow through the fabric (through time lag and amplitude reduction). It also stores the energy from incidental gains (solar radiation entering rooms through windows and casual gains). The delayed and stored energy can be utilised to contribute or even eliminate the auxiliary energy (supplied by the heating system) when the energy supply from nonsynchronous sources has ceased or is not sufficient enough to meet the demand.

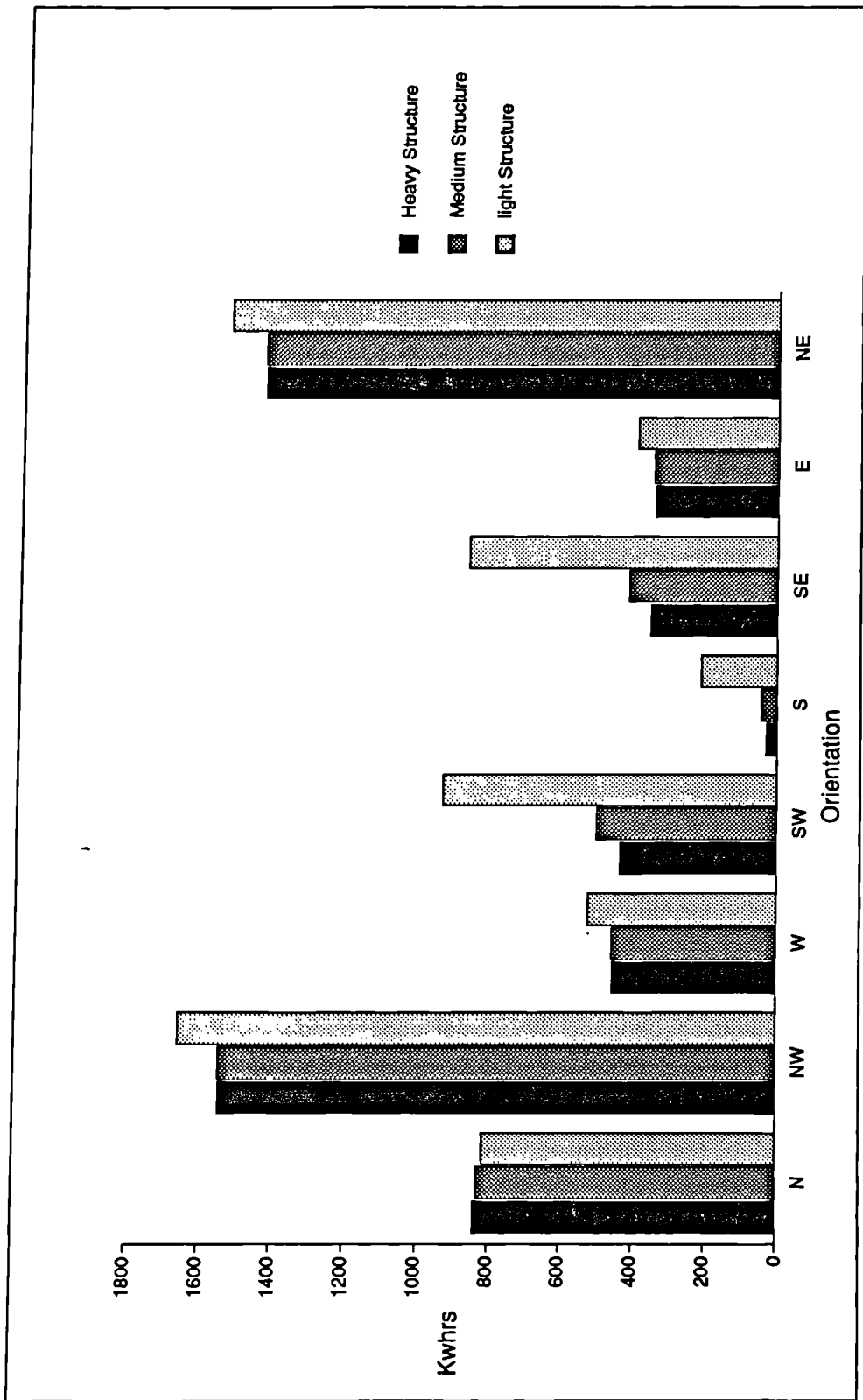

Figure 5.4 Annual heating requirements of rooms facing different orientations under continuous operation

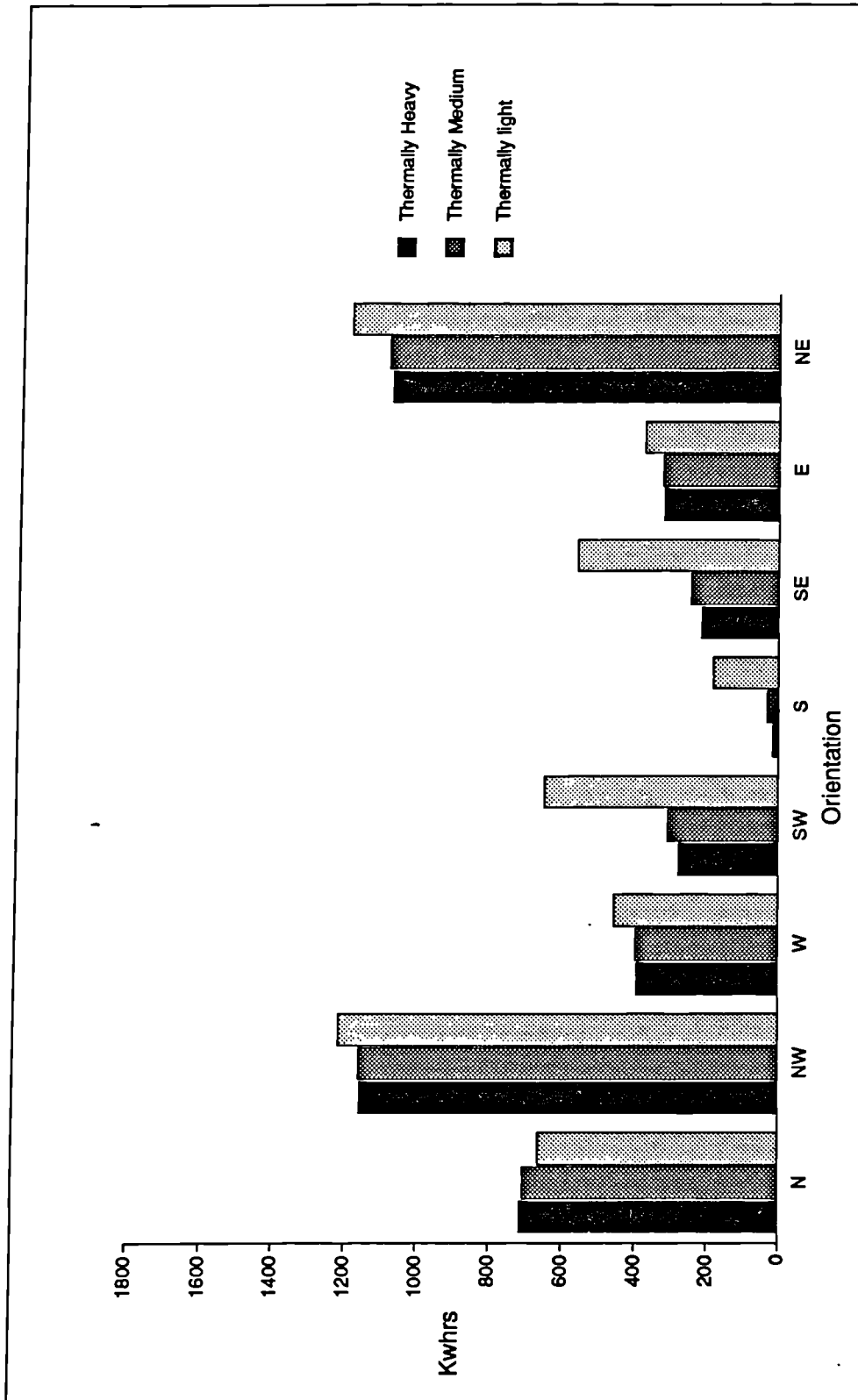

Figure 5.5 Annual heating requirements of rooms facing different orientations under intermittent operation

The combined effects of thermal mass and orientation on heating requirements may be highlighted by comparing the heating requirements of for example, south and east facing rooms of the thermally heavy and light models. Under continuous operation, the heating requirement of the south facing room (zone 2) of the thermally heavy model is smaller than the heating requirement of the south facing room of the thermally light building by 83%. The heating requirement of the east facing room (zone 6) of the thermally heavy model is smaller only by 13% than that of the east facing room of the thermally light model.

Under both continuous and intermittent heating regimes the heating requirements of all zones of the thermally heavy models, except that of its north facing room (zone 8), are smaller than the corresponding values for zones of the other two models.

The fact that the mass of the north facing room may cause energy penalties was expected. As discussed thermal mass may produce calculable energy savings if it can efficiently take advantage of available energy from nonsynchronous sources for example, fluctuations in incoming solar radiation.

In solar radiated south facing rooms the solar gains are high enough to raise the air temperatures above the thermostat set point. Figure 5.6 illustrates the temperature profiles for the south facing rooms of the thermally heavy and thermally light models on 14th of February. The temperatures in rooms occupied 24 hours (continuous operation) are higher because of the metabolic heat of

the occupants (overheating problems will be discussed later).

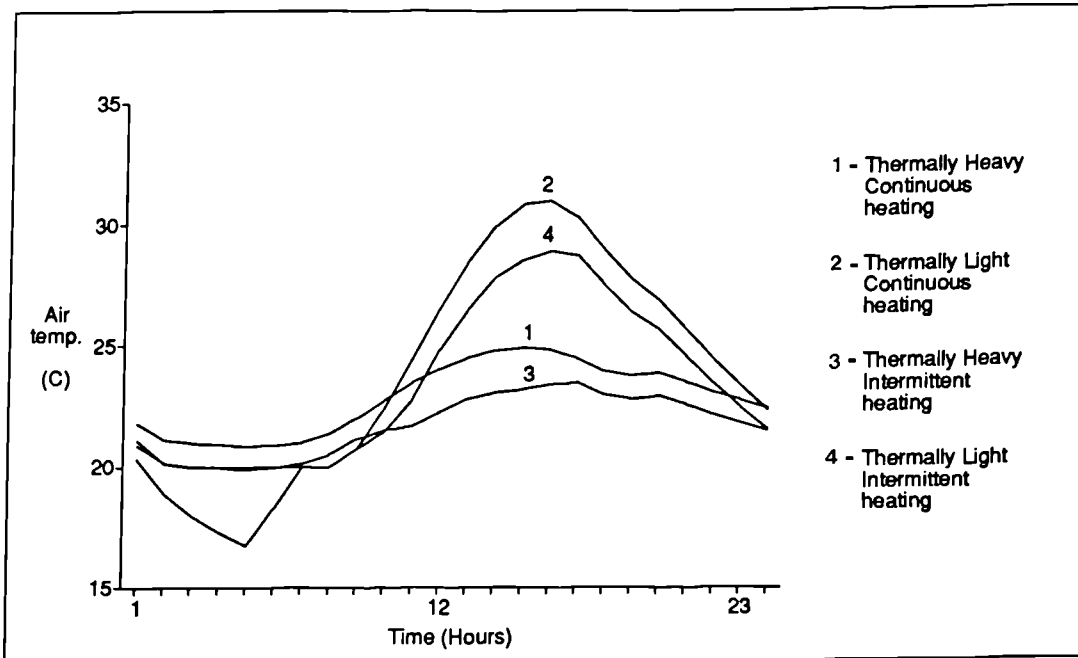
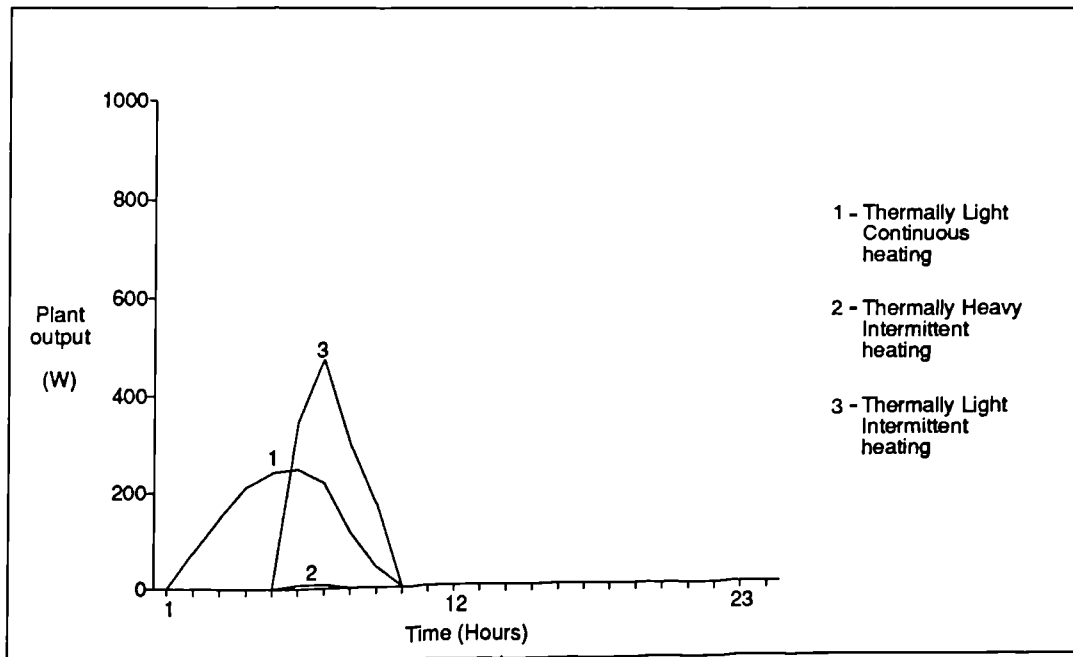

Figure 5.6 Air temperature in the south facing room (zone 2) (14th February)

Figure 5.7 depicting the plant output in south facing rooms on 14th of February, demonstrates the efficiency of thermally heavy structures in utilising energy from nonsynchronous sources. There is no need for auxiliary heating in the south facing room of the thermally heavy model under the continuous operation. Under intermittent operation, the plant needs to inject a small amount of heat in the early morning to raise the air temperature to 20 °C. The south facing room of the thermally light model however, requires some heating during the night and early morning to keep the air temperature at acceptable levels.



*Figure 5.7 Plant output in the south facing rooms
(14th February)*

Unlike the south facing rooms, north facing rooms do not receive any direct solar radiation through the windows for the entire heating season. Figure 5.8 shows that under continuous operation, the plant has to inject heat into the rooms every hour of the 24 hours to keep the air temperature constant at 20 °C (Figure 5.9). Under intermittent operation the plant needs to operate for most of the time during the controlled periods.

Except for a few hours in the early morning, when the plant has to inject more heat into the north facing room of the thermally light model to compensate for the lower air and/or intra-construction temperatures, the heat input by the plant into the thermally heavy room is higher than that in the thermally light room. This is

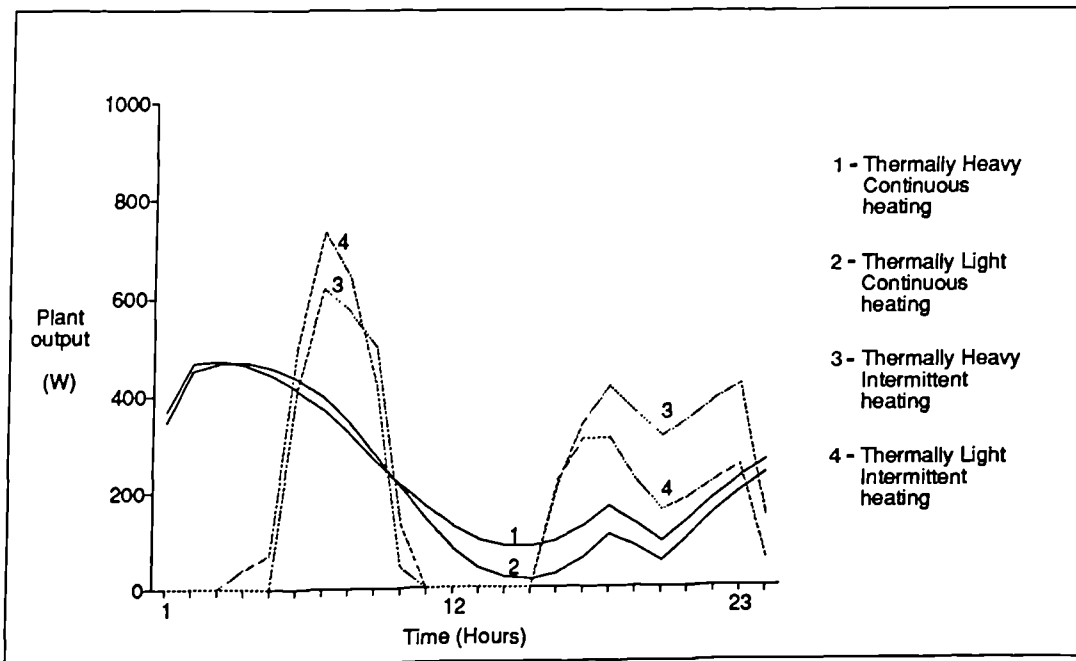

Figure 5.8 Plant output in the north facing rooms (14th February)

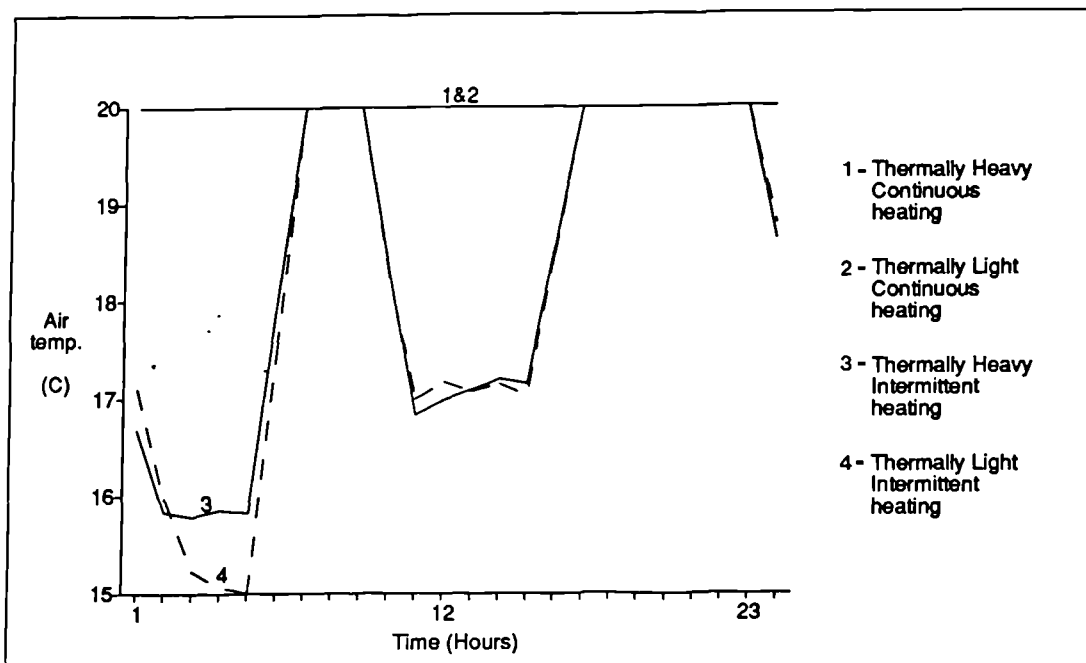

Figure 5.9 Air temperature in the north facing room (zone 8) (14th February)

because the plant has to compensate for the extra energy (both from the nonsynchronous sources and the heating plant) which penetrates into the thermal heat storage capacity of the thermally heavy structure some of which is lost to the outside.

The above analysis confirms the statement that "thermal mass functions effectively when fluctuations in the time-varying nonsynchronous energy sources are of significance". Under the conditions when the solar input is relatively small, for example as in the case of north facing rooms, thermal mass may even increase the loads. Under these conditions, the energy penalties of thermal mass are greater when the plant operates intermittently. Under continuous heating, the energy requirement of the north facing room of the thermally heavy model is greater than that of the north facing room of the thermally light model by 3%. The corresponding increase under intermittent heating is 8%.

The point which should be noticed in figures 5.4 and 5.5 is the poor thermal performance of zones 7 and 9 (indicated on figures by NW and NE orientations respectively). The large heat loss through the envelopes of these rooms in general and through the windows in particular has caused their heating requirements to be considerably higher (the area of the external wall and glazing of four corner rooms of the reference house is twice that of rooms facing cardinal orientations, see Figure 1.5, Chapter 1).

Figures 5.10 and 5.11 illustrate the annual cooling requirements of different zones. The high energy demands of the four corner rooms

emphasise the important design guideline for the design of buildings in hot dry climates; the exposure of the building to the external climate in general, and in particular to the sun should be minimised in summer. As the heat gain through glazing is more critical, the window area should be minimal and well protected.

As the north facing facades may be exposed to direct solar radiation only in early hours of mornings and late hours of afternoons during the summer, the cooling requirements of the north facing rooms are the least when compared with other zones. The preferable thermal environmental conditions of north facing rooms has inspired the traditional builders to allocate wherever possible some spaces facing toward north for summer use of the occupants.

Annual cooling and heating requirements of models are compared in figure 5.12. It may be concluded that for the situation considered, the thermally heavy building is the most energy efficient structure for cooling and heating whether continuous or intermittent control strategy is employed. There is a calculated increase in the cooling loads of the thermally medium and thermally light building to the thermally heavy building of 0.2% and 0.6% respectively when continuous cooling is applied. When intermittent cooling is employed these ratios are 1% and 6% respectively. The greater differences in cooling loads in favour of the thermally heavy building under intermittent cooling indicate advantage arising from nocturnal ventilation in thermally heavy buildings.

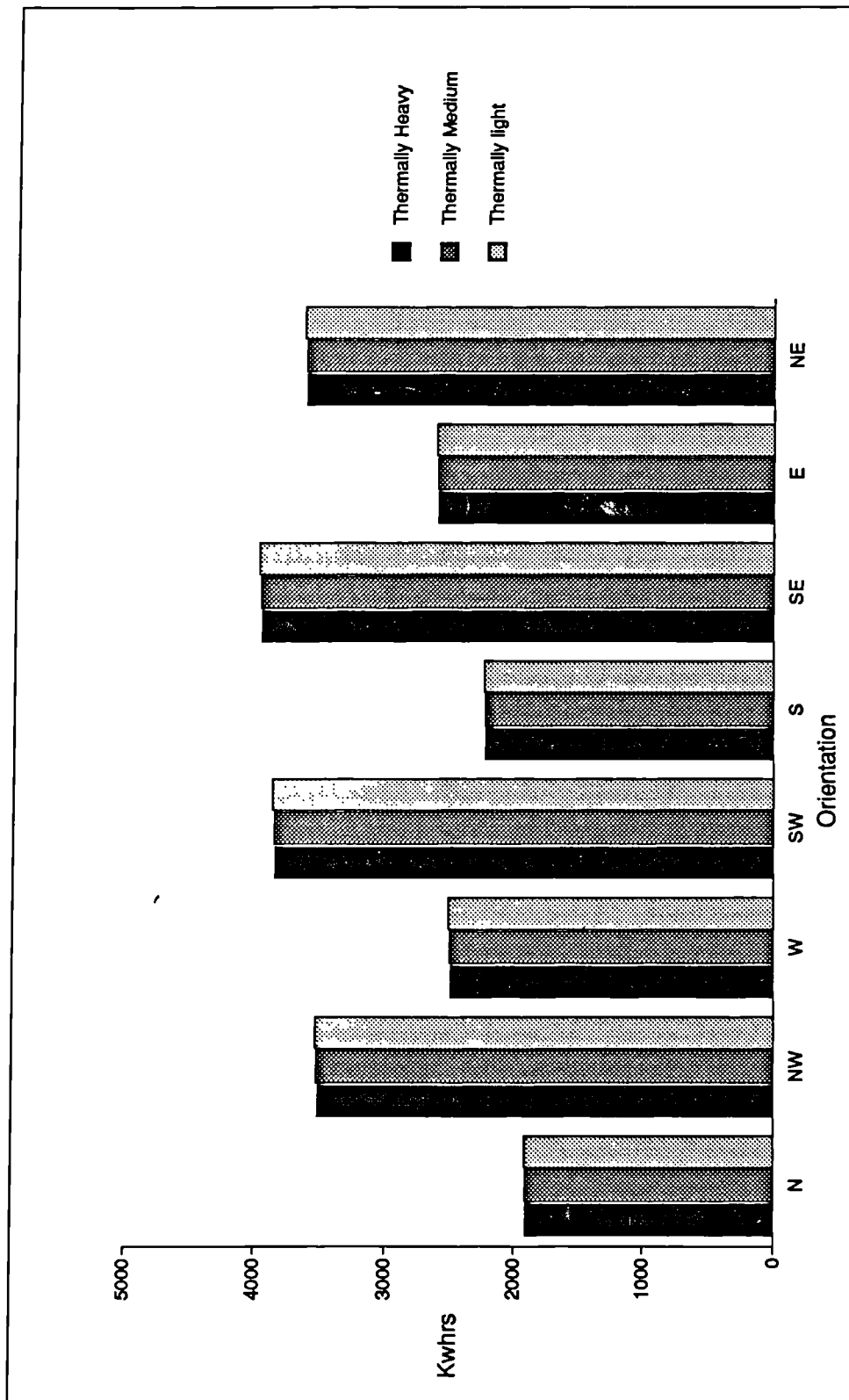

Figure 5.10 Annual cooling requirements of rooms facing different orientations under continuous operation

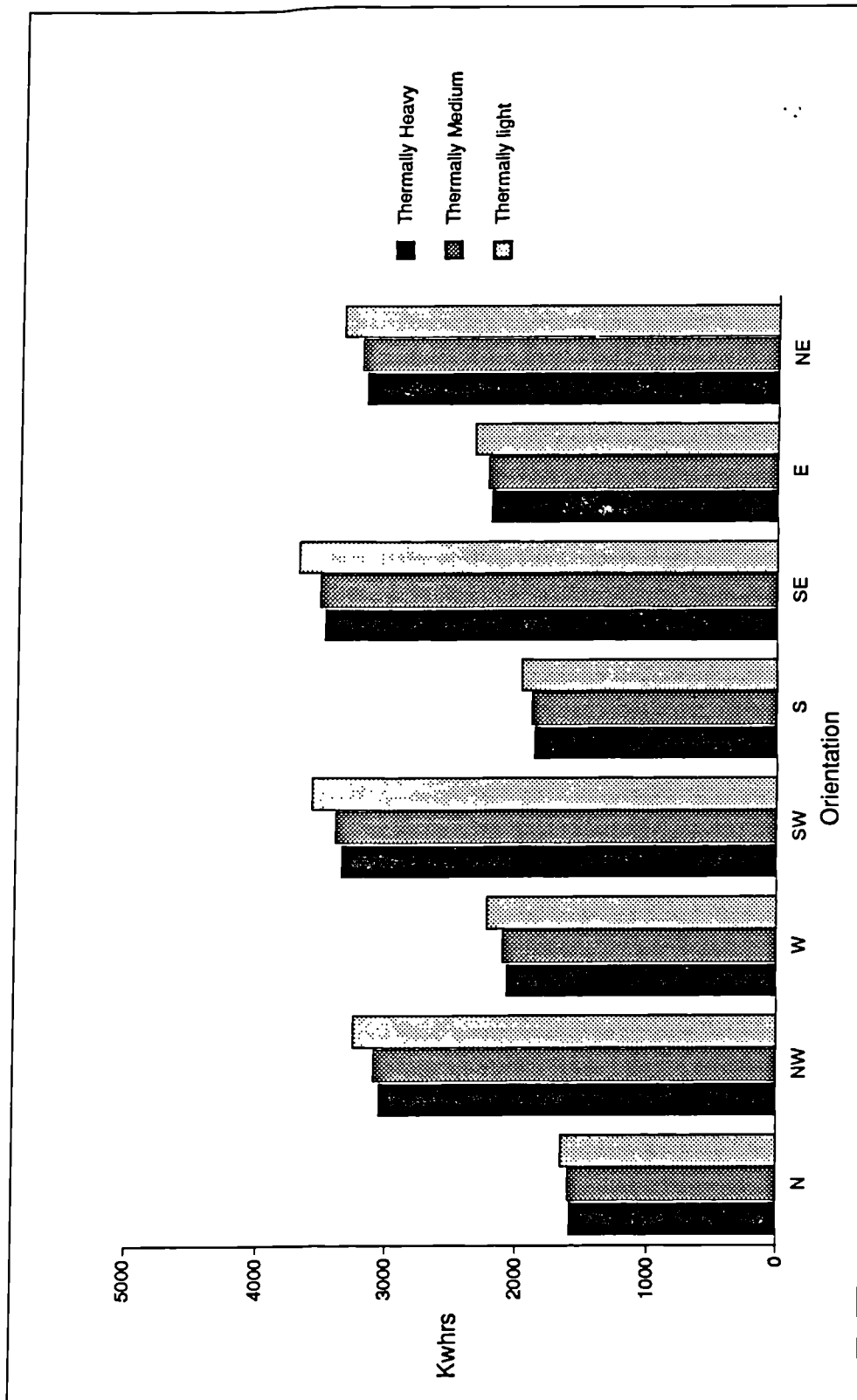

Figure 5.11 Annual cooling requirements of rooms facing different orientations under intermittent operation

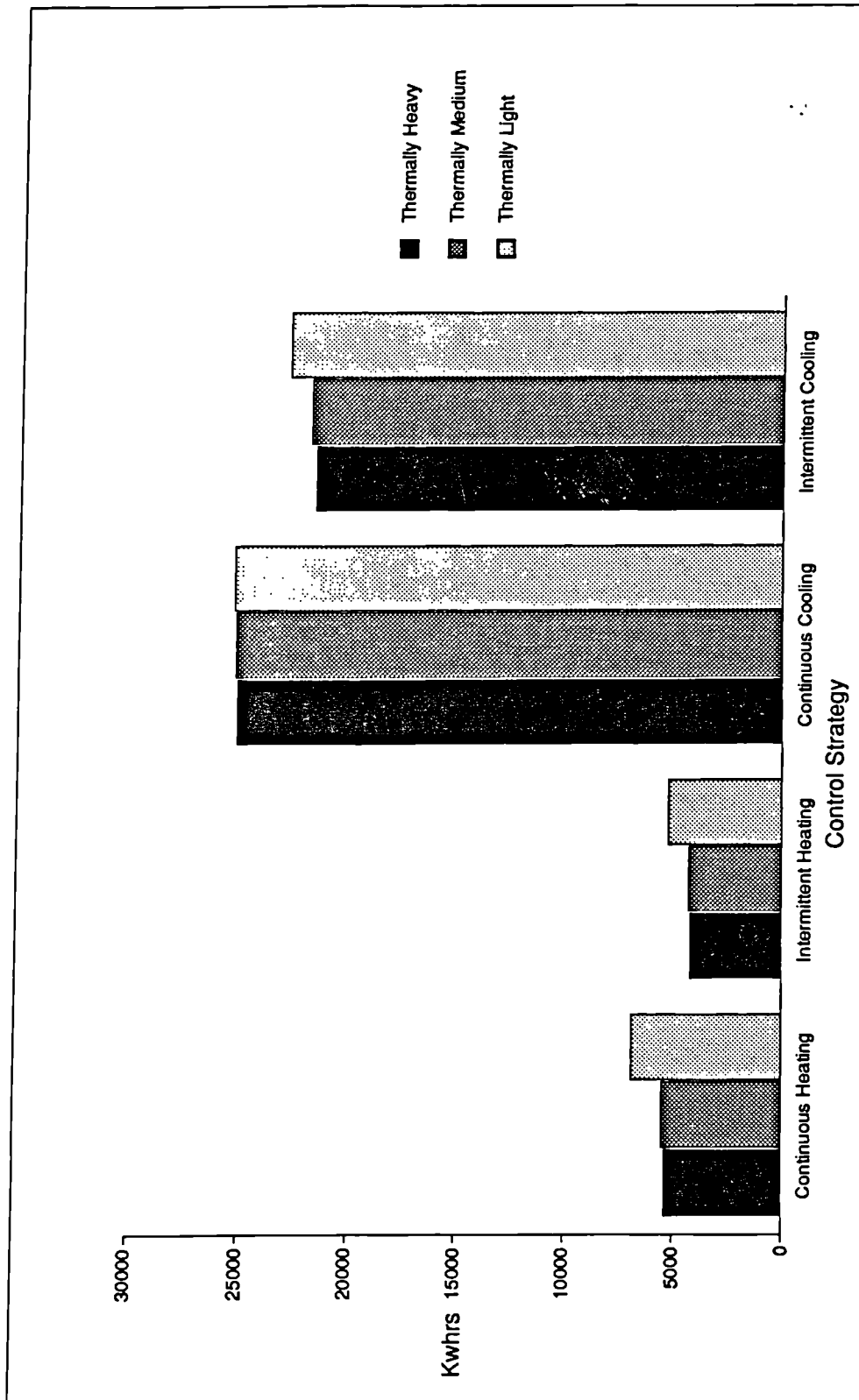

Figure 5.12 Annual energy requirements of model under different control strategies

The annual heating loads are more responsive to the modifications in the fabric although they are smaller in magnitude than the cooling loads. With continuous heating, the annual heating loads of the thermally medium and light buildings were 2% and 28% in excess of that of the thermally heavy building respectively.

With intermittent heating these were reduced to 1% and 23%. With continuous operation, the total annual energy requirements (heating and cooling) of the thermally medium and light buildings are 0.6% and 5% in excess of that of the thermally heavy building respectively. Under intermittent operation these are 1% and 9% respectively.

5.5 ENVIRONMENTAL INDICATORS : THERMAL COMFORT

The effects of thermal mass on the energy requirements of computer models were investigated in the preceding sections. "Environmental indicators", for example the thermal comfort of occupants may also be used to judge the effect of the environmental parameters of an enclosure which collectively with individual parameters influence the thermal sensation of the occupants. Chapter 3 examined the interactive effects of environmental and individual parameters on the thermal sensation of the occupants. The following paragraphs aim at analysing the effect of the thermal mass on the thermal environment of buildings. Overheating risk (the number of hours in which the air temperature of an enclosure exceeds a given limit) together with Fanger's comfort models (which determine the degree of

discomfort caused by the collective effects of all parameters) have been used as determinants to assess indoor thermal conditions of models.

The ability of thermal mass in dampening the internal temperature swings was illustrated in Chapter 4 (for example see Figures 4.11 and 4.12). Under conditions when a space is not subject to full conditioning, for example under the control regimes chosen for this study, or when buildings are free-floated (no control at all), fluctuations in indoor temperature may be as the result of one or more of the following potential sources of nonsynchronous energy:

- *the daily swings in outdoor temperature (temperatures of opportunity)*
- *Casual gains*
- *fluctuations in incoming solar radiation*

In the simulations whose results are reported here, in the cooling season space cooling existed during every hour of the day and consequently the internal air temperatures of houses were always at thermostat set point temperature, 22 °C. Under intermittent cooling, when nocturnal ventilation was provided at night, the internal temperatures of houses were 2 to 3 °C above the night time temperature. The internal night time air temperatures of the thermally light building were slightly lower than the thermally heavy building but the differences in most cases were too small to have any effect on the thermal sensation of the occupants.

In the following paragraphs only examples of the thermal comfort analysis for the heating season are presented. This is because (unlike in the cooling season when calculated *PPDs* are not noticeably different because of the constant air temperature during days and small differences at nights) differences in air temperatures and comfort votes are large enough to be compared visually.

As the thermally light buildings respond more rapidly to energy gains (from nonsynchronous sources) the overheating risk in winter in the thermally light building is higher than that in the thermally heavy buildings. CIBSE Guide [13] suggests that the maximum peak temperature should not frequently exceed 27 °C, otherwise the thermal environment of the enclosure will become uncomfortably hot.

Table 5.1 gives the frequency of excessive temperatures during the winter (from November to March) in intermittently heated houses. The table lists the number of hours in which the internal air temperature has exceeded 27 °C. The overheating risk is higher in zones receiving greater quantities of solar radiation, for example, zones facing south. As the table shows the number of hours in which excessively high temperatures may occur in the thermally light model is considerably higher than in the thermally heavier models.

Under continuous heating when houses are occupied during the day, the metabolic heat of the occupants will contribute to higher room temperatures. The numbers of hours in which air temperatures have exceeded 27 °C are considerably higher under continuous operation

(Table 5.2) than intermittent operation. The numbers clearly indicate that thermally light buildings can be prone to excessive internal temperatures.

Table 5.1 Frequency of excessive temperatures (hours) occurring in different zones ($t_{air} > 27\text{ }^{\circ}\text{C}$)
Operation : Intermittent, Period : November to March (5 months)

M o d e l	Zone (Orientation)									Total
	1 (SW)	2 (S)	3 (SE)	4 (W)	5 -	6 (E)	7 (NW)	8 (N)	9 (NE)	
H	39	0	0	0	0	0	0	0	0	39
M	78	0	0	0	0	0	0	0	0	78
L	461	535	519	98	0	0	37	0	0	1650

H = Thermally Heavy model

M = Thermally Medium model

L = Thermally Light model

Table 5.2 Frequency of excessive temperatures (hours) occurring in different zones ($t_{air} > 27\text{ }^{\circ}\text{C}$)
Operation : continuous, Period : November to March (5 months)

M o d e l	Zone (Orientation)									Total
	1 (SW)	2 (S)	3 (SE)	4 (W)	5 -	6 (E)	7 (NW)	8 (N)	9 (NE)	
H	96	0	37	0	0	0	0	0	0	133
M	118	59	97	0	0	0	0	0	0	274
L	601	758	702	138	60	77	58	0	0	2394

H = Thermally Heavy model

M = Thermally Medium model

L = Thermally light model

To illustrate the thermal response of the models to fluctuating energy sources (nonsynchronous sources), two examples of their temperature profiles are presented here. Figure 5.13 depicts the air temperatures in the south-east facing rooms (zone 3) of models on 14th February under intermittent heating. Figure 5.14 illustrates the corresponding temperatures in south-west rooms (zone 1).

The temperature profiles not only indicate that the thermally light buildings are more prone to high temperatures than the thermally heavy structures but they may also experience unacceptably low temperatures. Put another way, the temperature ranges in the thermally light structures are wider than in the thermally heavy buildings, i.e. they are more prone to temperature swings.

Figure 5.15 illustrates the temperature ranges on 14th February under intermittent heating in rooms versus orientation by showing both the calculated maximum and minimum temperatures. Greater temperature ranges have occurred in the thermally light model compared with the other two models. Night-time temperatures in most zones (zones facing N, NW, SW, SE and NE) of the thermally light building have fallen to the thermostat set point (15 °C) indicating the need for the heating plant to operate. The plant has only supplied heat into two rooms (NW and NE) of the thermally heavy model to prevent their temperatures falling below the acceptable limit.

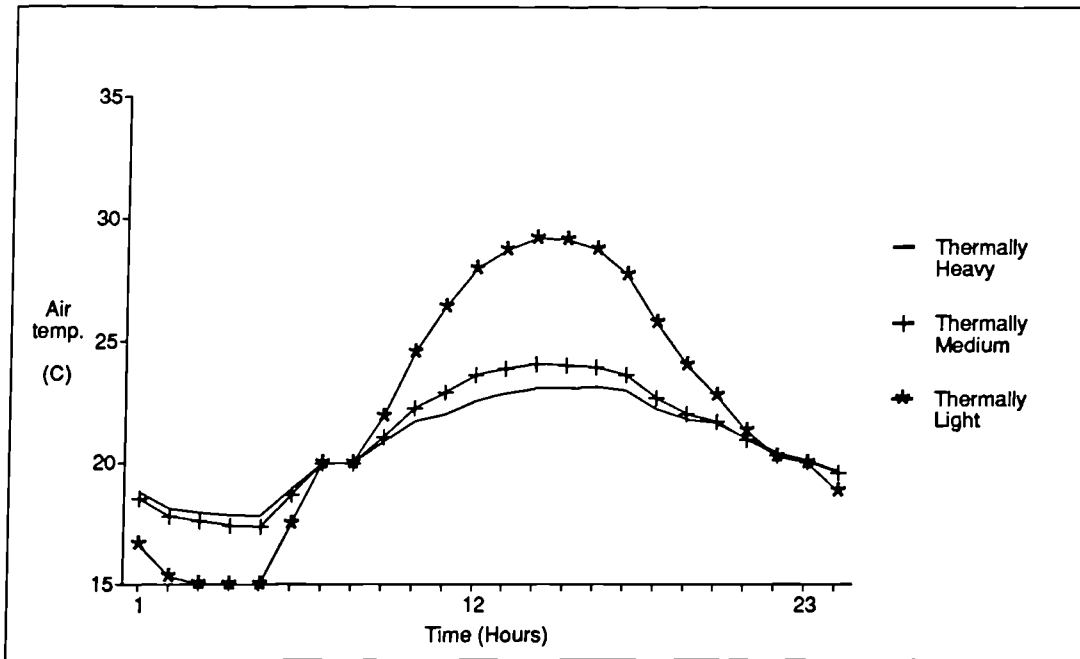

Figure 5.13 Air temperature in the south-east facing room (zone 3) on the 14th of February under intermittent operation

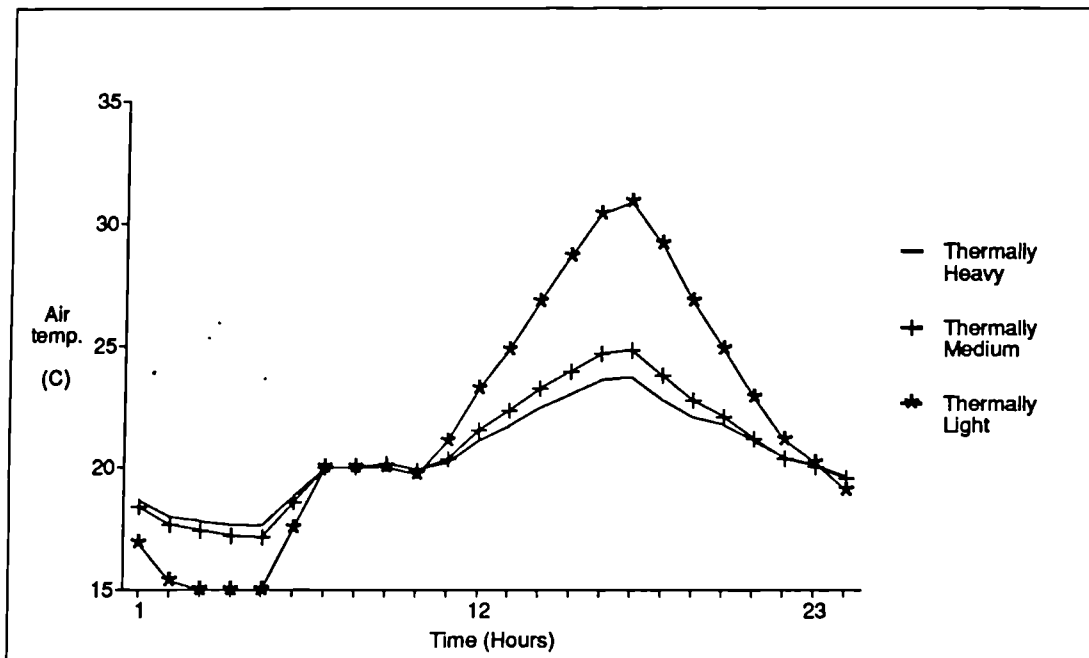

Figure 5.14 Air temperature in the south-west facing room (zone 1) on the 14th of February under intermittent operation

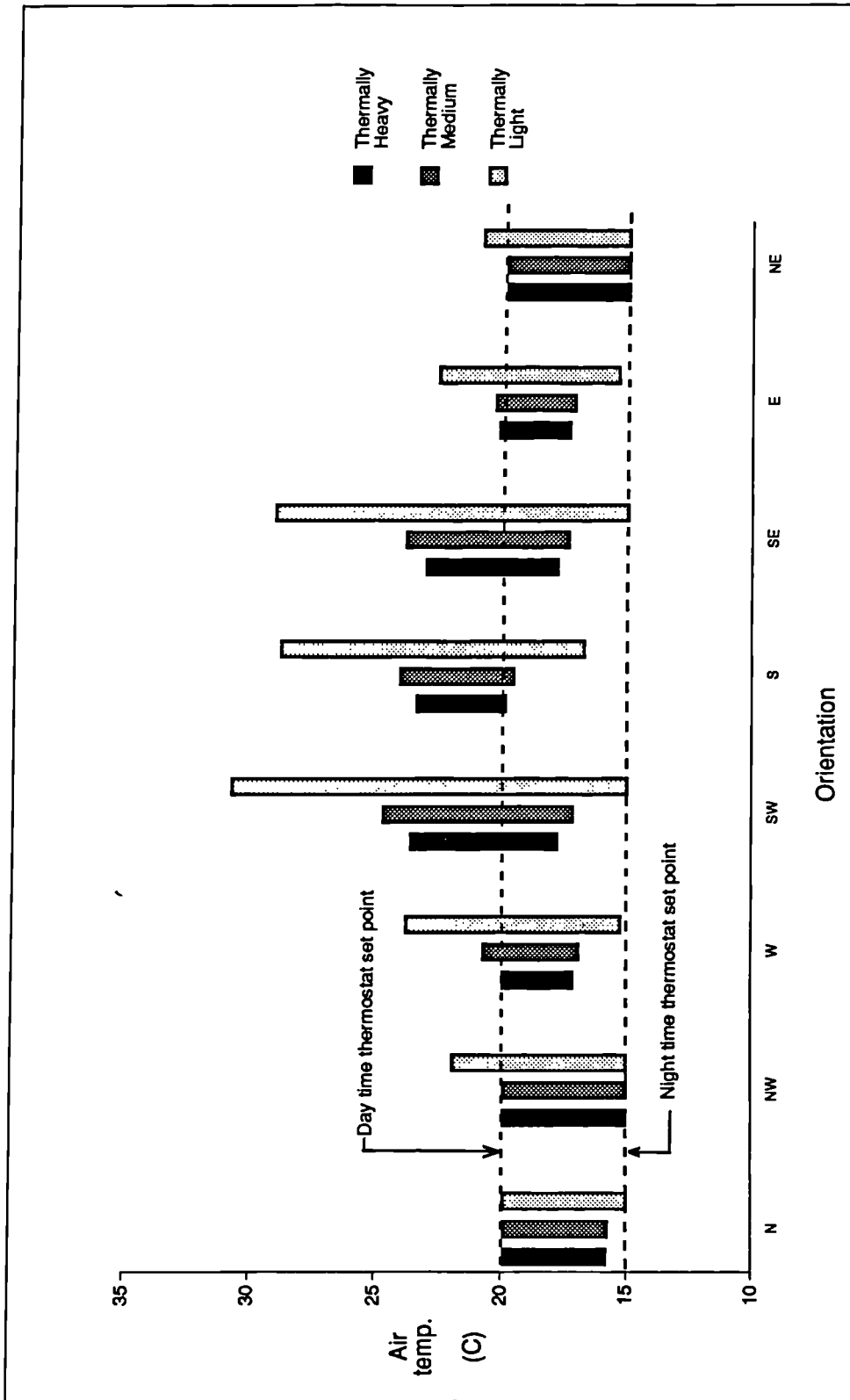

Figure 5.15 Temperature ranges in rooms facing different orientations
(Intermittent operation - 14th February)

The effect of thermal mass on the air temperature changes under free-floating conditions, i.e. in models whose internal spaces are not conditioned, was also studied. The temperature profiles confirmed that thermally light structures respond more rapidly to changes of energy loss or gain creating a more volatile environment. As an example, the temperature profile for the south facing rooms of the three models under free-floating conditions is presented in reference 14 (see Appendix C).

Fanger's comfort models (*PMV* and *PPD*) were used to assess the thermal comfort conditions inside the models. To highlight the effect of thermal mass on the thermal comfort of the occupants, the results of the comfort analysis for the intermittently thermally heavy and light models over a one week period in February are reported here. In calculation of *PMVs* given in figures 5.16 to 5.19 values of clothing resistance (*clo*), and air motion were assumed to be 1 and 0.1m/s respectively as were recommended in Chapter 3 for winter conditions.

The further away from zero, which presents the neutral conditions (see the scale given in Chapter 3) indicates the more dissatisfaction. The large temperature fluctuations in the thermally light building have led to higher values of *PMV*. As explained in Chapter 3, any value for *PMV* corresponds to a Predicted Percentage of Dissatisfied (*PPD*) as the result of being exposed to the thermal environment of the enclosure. Corresponding values of *PPD* for calculated *PMVs* given in figures 5.16 to 5.19 may be obtained from figure 3.1 given in Chapter 3.

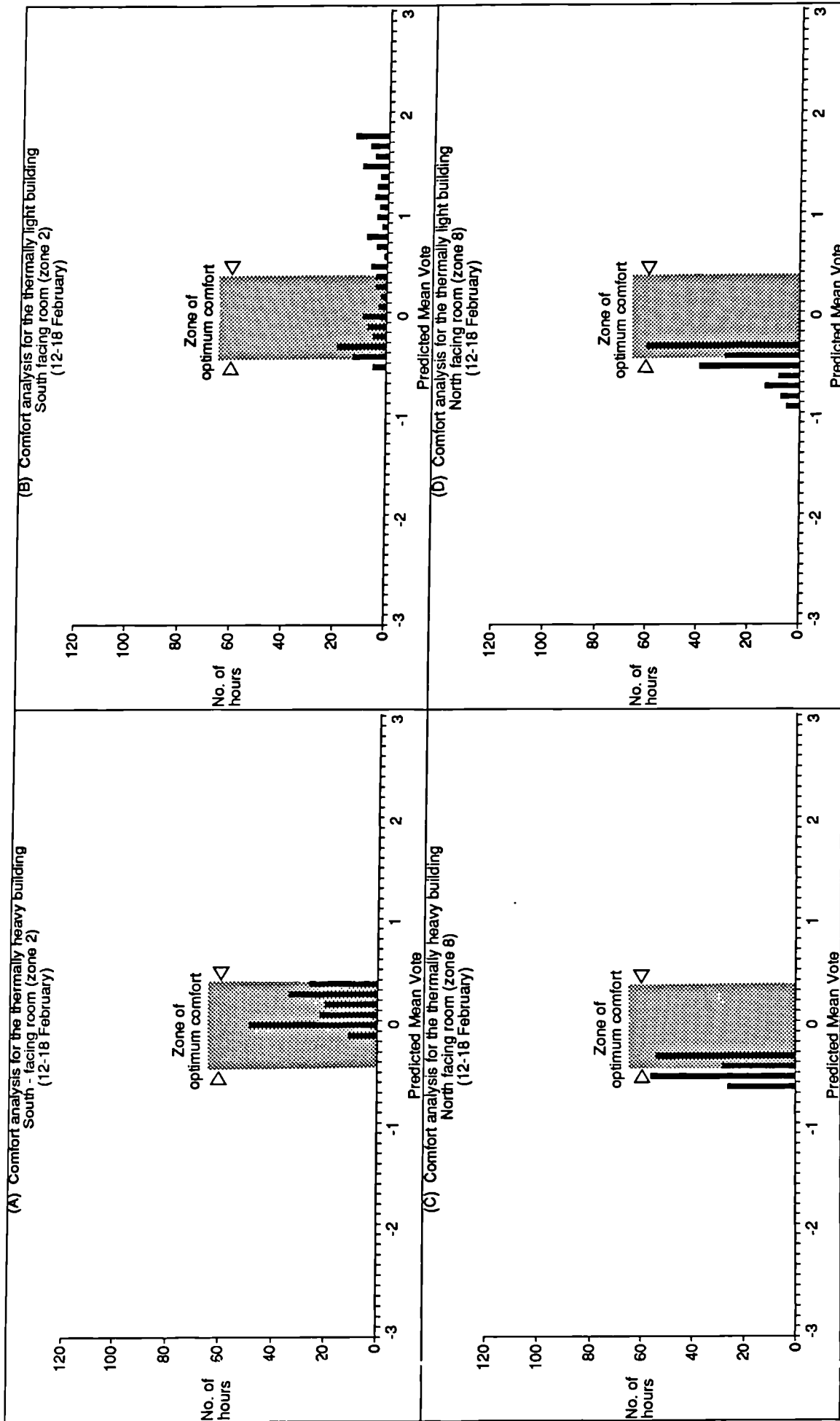

Figure 5.16 Comfort Analysis

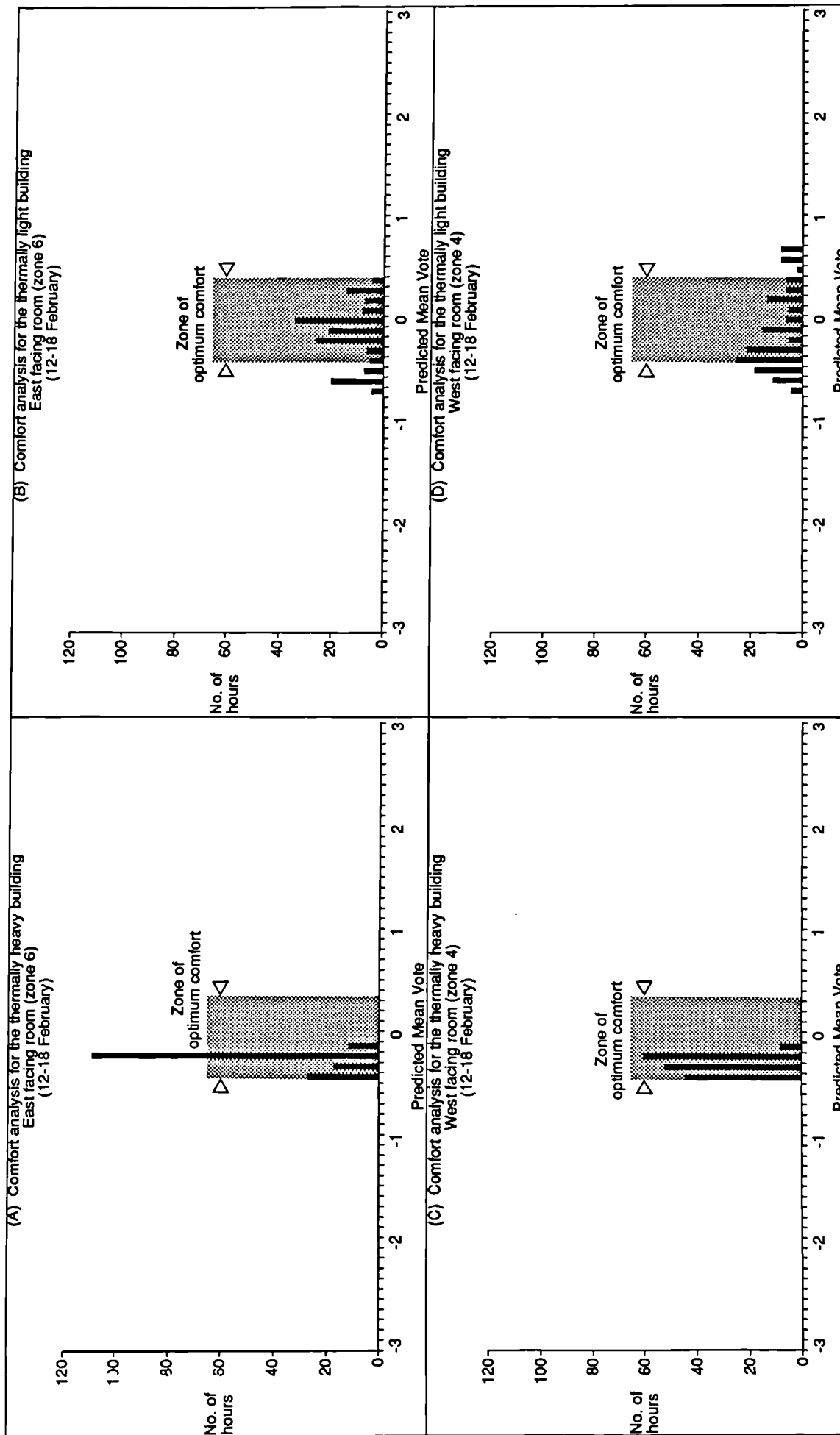

Figure 5.17 Comfort analysis

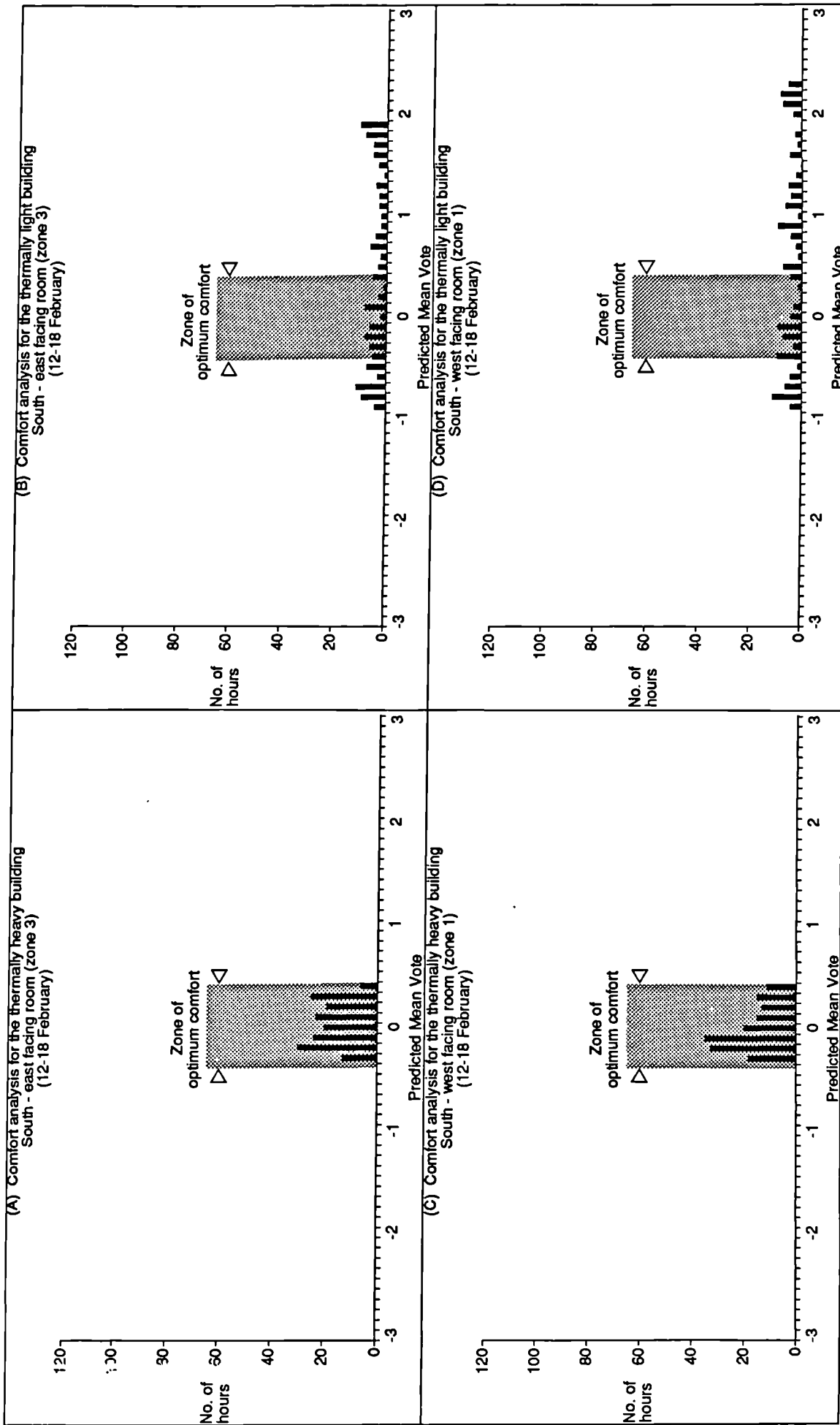

Figure 5.18 Comfort analysis

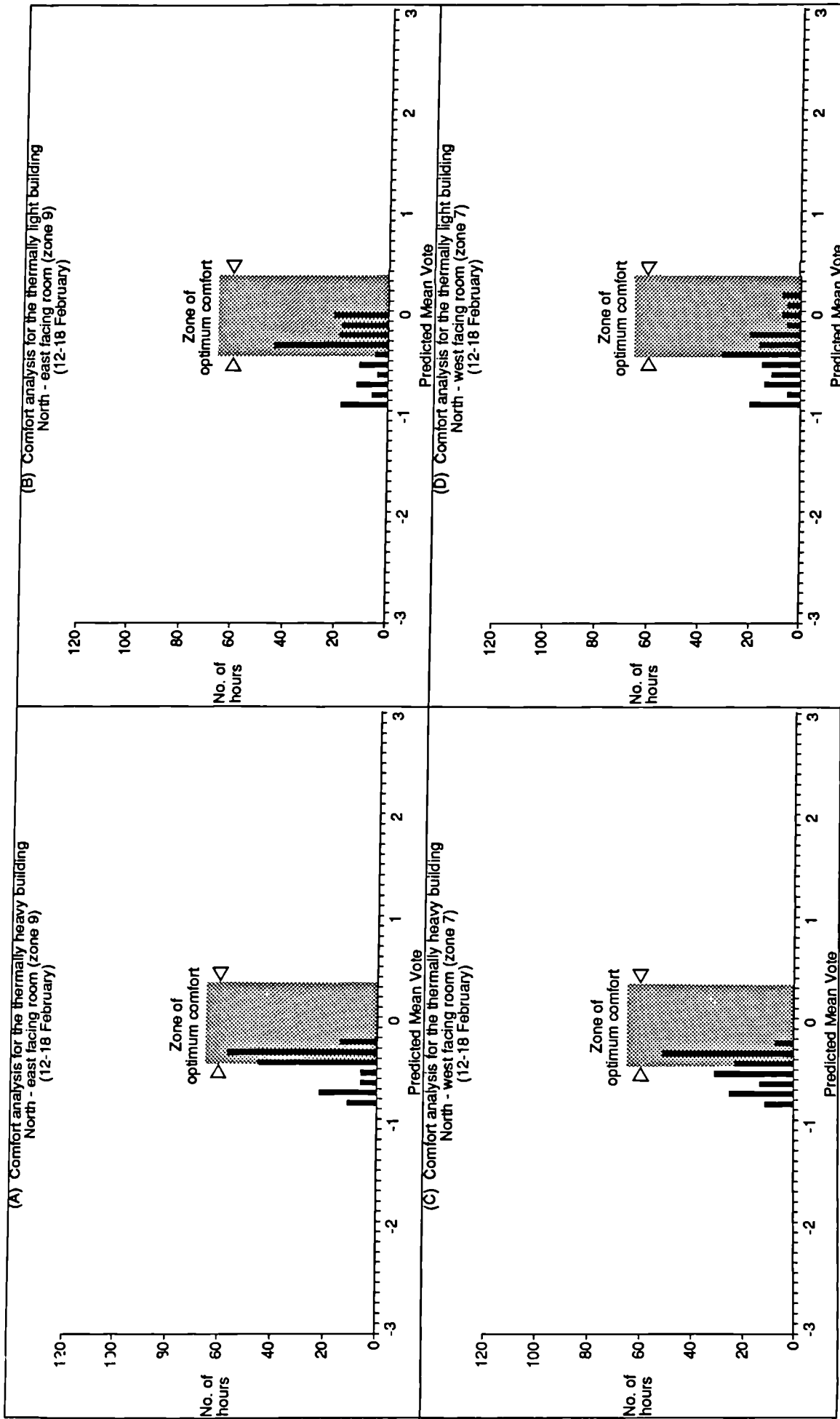

Figure 5.19 Comfort analysis

Shown on figures 5.16 to 5.19 is also the zone of optimum comfort. The zone corresponds to the range of *PMVs* (+ 0.35) for which the number of dissatisfied people would not exceed 7.5% (see Chapter 3).

Figures 5.16 to 5.19 clearly illustrate that thermal environment of the thermally heavy buildings is more comfortable than that in the thermally light buildings. The number of hours in which discomfort persists is considerably higher in the thermally light building.

As the temperature ranges given in figure 5.15 suggest, a high level of thermal dissatisfaction would be expected in the south facing rooms of the thermally light building. For example, the maximum calculated value for *PMV* in the south-east facing room of the thermally light building is +1.9 (see figure 5.18B). The corresponding *PPD* is about 72%, meaning that during a week in February the thermal environment of the south-east zone of the thermally light model may become so hot that 72% of people exposed to that environment would complain. If the votes of the occupants are averaged over the week, we will have an average value for *PPD* of about 27%.

The thermal conditions of the south-east room in the thermally heavy model is much more favourable (Figure 5.18A). During the same week in February, the maximum percent of people who may complain about the thermal conditions of the room is only 9%. This corresponds to a *PMV* of about +0.4. The averaged values of *PPDs* over the week is of the order of 5.8%.

Table 5.3 gives the maximum and averaged *PPD* votes (for the week period) calculated from *PMVs* given in figures 5.16 to 5.19. The percentage of the people dissatisfied with their thermal environment is considerably lower in the thermally heavy model. The excessive high temperatures in the thermally light model have led to a high level of thermal dissatisfaction.

Table 5.3 Comfort analysis : maximum and averaged values of *PPD* over a week in February. (Operation : Intermittent)

Model	Zone (orientation)								
	1 (SW)	2 (S)	3 (SE)	4 (W)	6 (E)	7 (NW)	8 (N)	9 (NE)	
H	Max.	9	9	9	9	9	19	13	19
	Ave.	5.9	6.1	5.8	6.7	6.3	9.5	9.4	10
L	Max.	85	68	72	16	16	23	23	23
	Ave.	25.4	22.5	26.9	8.8	7.2	10.5	9.8	9.8

H = Thermally Heavy model

L = Thermally Light model

The results of analysis indicated that the energy requirements of buildings may be significantly reduced by employing intermittent control strategies. Due to the rising energy cost, people are now more conscious of taking advantage of natural sources of energy for heating and cooling buildings whenever possible. Further studies on the effect of design solutions on the energy requirements and thermal performance of buildings will be carried out under the more currently used intermittent strategies.

5.6 REFERENCES

- [1] Burch, D.M., Krintz, D.F. and Spain, R.S. *The effect of wall mass on winter heating loads and indoor comfort. An experimental study.* ASHRAE Transactions, Vol. 90, Part 1B, 1984.
- [2] Burch, D.M., Malcolm, S.A., and Davis, K.L. *The effect of wall mass on the summer space cooling of six test buildings.* ASHRAE Transactions, Vol. 90, Part 2B, 1984.
- [3] Arumi, F.N. and Burch, D.M. *DEROB simulation of the NBS thermal mass buildings.* ASHRAE Transactions. Vol.90, Part 2B, 1984.
- [4] Kostiuk, L.W. and Dale, J.D. *Energy characteristics of a residential masonry structure.* ASHRAE Transactions, Vol. 93, Part 1, 1987.
- [5] Hopkins, V., Gross, G. and Ellifritt, D. *Comparing the thermal performances of buildings of high and low masses.* ASHRAE conference, Philadelphia, 1979.
- [6] Rudoy, W. and Dougall, R.S. *Effect of the thermal mass on heating and cooling load in residences.* ASHRAE conference, Philadelphia, 1979.
- [7] Spooner, D.C. *Thermal capacity.* Building, Vol.234, 12 May 1978.
- [8] Basnett, P. *Thermal capacity and energy requirements in well insulated houses.* Proceedings of the 2nd international symposium on energy conservation in the built environment. Copenhagen 1979.
- [9] Udagawa, M. and Ishida, K. *Effect of insulation and heat capacity on the thermal performance of residential houses.* Proceedings of the CLIMA 2000, world congress on heating, ventilating and air - conditioning. Copenhagen, August 1985.
- [10] Goodwin, S.E. and Catani, M.J. *The effect of mass on heating and cooling loads and on insulation requirements of buildings in different climates.* ASHRAE Transactions, Vol. 85, Part 1, 1979.
- [11] Arumi, F.N. *Thermal inertia in architectural walls.* National Concrete Masonry association, USA, 1977.
- [12] Catani, M.J. *Insulation and the M Factor.* ASHRAE Journal, Vol. 20, No. 6, 1978.
- [13] CIBSE GUIDE, Volume A, The Chartered Institution of Building Services Engineers, 1986.
- [14] Sodagar, B. and Warren, B.F. *The effect of mass on comfort and energy requirements in hot dry climates.* Proceedings of the XIth CIB International Congress on the Quality for Building Users Throughout the World, User Comfort, Paris, June 1989.

Chapter 6

THE EFFECT OF ROOF DESIGN ON THE THERMAL PERFORMANCE OF BUILDINGS

- 6.1 Introduction
- 6.2 Classification of flat roofs with regard to insulation position
- 6.3 The effect of colour and thermal resistance of roofs on their surface temperatures
- 6.4 The effect of colour and thermal resistance of roofs on heating and cooling loads
- 6.5 Roof shading
- 6.6 Economic considerations
- 6.7 References

6.1 INTRODUCTION

Although the thermal design of roofs has been the subject of extensive research in cold climates, it has not been given adequate attention in warm climates.

The roof is the building element most exposed to the climate. The impact of solar radiation on clear days in summer, loss of heat by longwave radiation during the night and in winter, and factors such as rain and snow affect the roof more severely than any other part of a building.

In cold climates, the effect of the roof on the thermal performance of buildings is usually in one direction, it serves as a major potential route for heat loss. In hot dry climates, heat transfer through a roof is usually dual in direction. The heat waves penetrate into the structure during the day as the result of high surface temperatures caused by high air temperature and solar radiation falling on the roof. The direction of waves traversing through the roof is usually reversed at night due to heat losses at the external surface of roofs by convection and longwave radiation. As mentioned in Chapter 2, clear night skies in the tropics provide a potential radiative sink for effective heat loss by thermal infrared radiation emitted from surfaces.

The study is restricted to flat roofs which are the most common types in the region in question. Other types of roofs, for example pitched roofs are rarely used.

6.2 CLASSIFICATION OF FLAT ROOFS WITH REGARD TO INSULATION POSITION

The roof is a building component composed of different elements each of which is usually required to perform a well defined function, e.g. the structural deck to carry the load imposed on the roof, insulation to control the flow of heat, waterproof covering to prevent the penetration of water, vapour check to control the migration of water vapour, and so on.

The three principal parts of a flat insulated roof, the deck, the insulation and the waterproof membrane, can be positioned to give three practical and technically acceptable arrangements. These are known as the "cold deck" and the "warm deck" types of design, the latter having two variations usually referred to as "warm roof" or "sandwich" and "protected membrane roof". Figure 6.1 shows the main elements in different types of flat roofs.

In the "warm roof" the insulation is placed above the deck, so that the deck is warm. In the "cold roof", the thermal insulation is placed below the roof deck normally at ceiling level, therefore the deck is exposed to the outside climate and is cold. These categories are therefore classified regarding the roofs of heated buildings.

In the "warm roof", the thermal insulation is placed between the deck and the waterproof membrane. This is why this type of roof is referred to as the sandwich type.

Figure 6.1 Roof Types

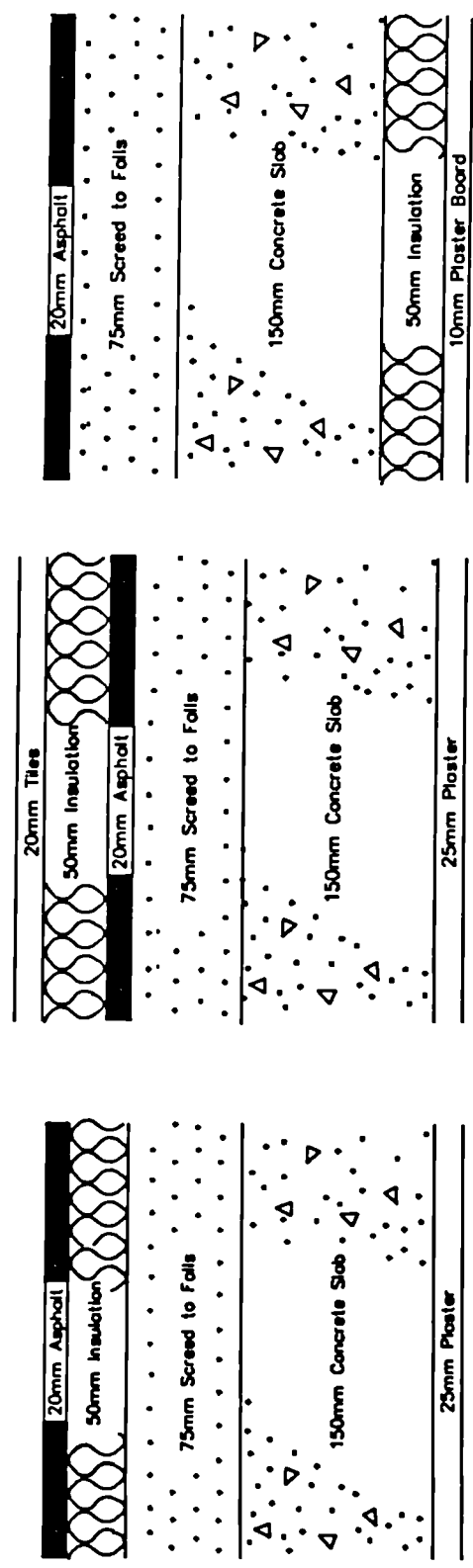

Warm Roof Protected Membrane Roof Cold Roof

The basic concept of the "protected membrane roof" is to protect the waterproof membrane from the influence of climatic factors such as uv-radiation, very high and low temperatures, etc. This is achieved by placing the insulation material on the top of the roof membrane, thus exposing the insulation material to the climate instead. Comparing its configuration with that of the "warm roof", the position of the waterproof membrane and the insulation material is reversed, letting this kind of roof to be also called the "upside down" or the "inverted roof". Protected membrane flat roofs have been used in the US, Canada, and Europe for a number of years with generally good results [1]. One of the advantages of the "protected membrane roof" is the ability to upgrade the insulation without disturbing the waterproof membrane [2].

In the forthcoming paragraphs, the roofs whose thermal behaviours are cited have the construction details shown in figure 6.1 unless specified otherwise. The construction details of the other elements of the reference house are given in table 6.1.

The "cold roof" thermally behaves as a light structure as the thermal heat storage capacities of its masonry layers are isolated from the interior. As found in the previous chapters (Chapters 4 & 5), the available thermal heat storage capacity of the building envelope is more effective when is positioned inside, as opposed to outside. The thermal performance of the "warm roof" and the "protected membrane roof" with respect to the internal environment and energy use is similar as the spatial disposition of the layers in their multi-layer constructions is almost similar. Since from a

construction point of view the "warm roof" represents the most commonly used, further studies will be carried out on this type. Internal boundary conditions are assumed to be those by employing intermittent operations given in table 1.2 in Chapter 1. External surface absorptivities of surfaces are assumed to be 0.5 unless other values are specified otherwise.

Table 6.1 Construction details

Floor	150mm	concrete
	150mm	hard-core
	100mm	earth
External walls	220mm	brick wall
	25mm	plaster
Partitions	25mm	plaster
	105mm	brick wall
	25mm	plaster

As was investigated in the previous chapters, the location of the insulation layer in a composite structure dictates the pattern of the heat flow through it. Thermal mass is more effective in reducing the internal surface temperature fluctuations when it is positioned inside, as opposed to outside (see Figures 4.12A and 4.12B, Chapter 4). Figure 6.2 illustrating the ceiling temperatures of the "warm" and "cold" roofs on the 21st of July, indicates that the ceiling of the "cold roof" experiences wider temperature fluctuations than the ceiling of the "warm roof" (the U - values of roofs are identical).

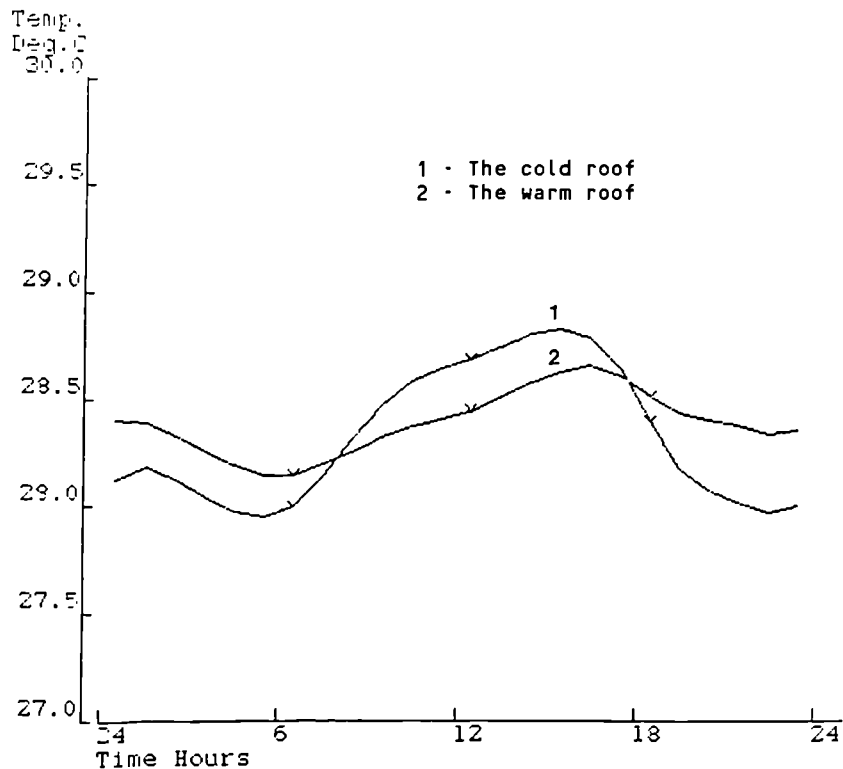

Figure 6.2 Ceiling temperatures of the warm and cold roofs on the 21st of July

The examination of figure 6.2 also reveals that the maximum and minimum ceiling temperatures of the "warm roof" are delayed compared with those of the "cold roof". This is because the thermal heat storage capacity of the "warm roof" is more effective in giving rise to a delay, or a "time lag", and attenuation of the energy flow through the roof than in the "cold roof" in which the mass is thermally isolated from the interior.

Waterproof membranes for flat roofs in tropics are based mainly on bituminous materials [3]. So far as the durability of a bituminous material is concerned the most aggressive factor is solar radiation, which is manifested not only as temperature but also as photo-chemical effects.

On the basis of the results of Chapter 4, one would expect the temperature of the asphalt to be lower in the "cold roof" than in the "warm roof". Applying thermal insulation beneath the asphalt allows this upper layer to be overheated by preventing heat loss from its lower surface to layers below. This is illustrated in figure 6.3 where the surface temperature of the asphalt in the "warm roof" is higher than that of the "cold roof" for most of the day (21st of July). The maximum surface temperature of the asphalt layer of the "warm roof" is about 2.8 °C higher than the corresponding value for the asphalt in the "cold roof".

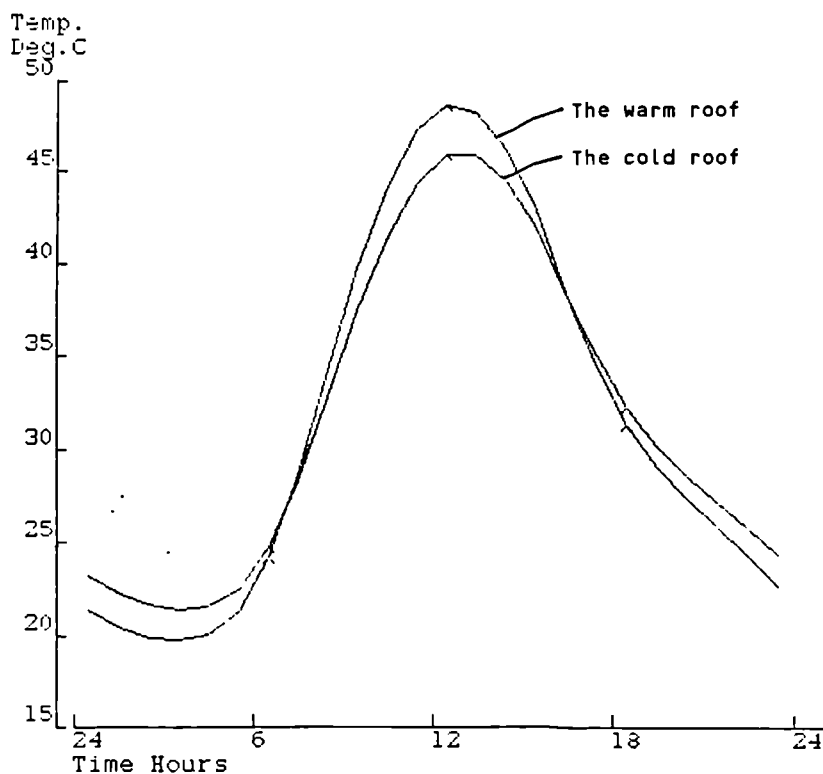

Figure 6.3 Roof surface temperatures of the warm and cold roofs on the 21st of July

In the "protected membrane roof", it is an advantage that the thermal insulation protects the asphalt layer from reaching high temperatures. It is also an advantage that the asphalt is protected from low temperatures minimising the risk of thermal shocks and stress caused by wide swings in temperatures. Figure 6.4 illustrates two ranges of temperature fluctuation: the wide band shows the range of temperatures for the unprotected asphalt in the "warm roof", the narrower band shows the range of temperatures of the asphalt in the "protected membrane roof". The external surfaces of roofs are assumed to be of dark colours having a solar absorptivity value of the order of 0.85. As it can be seen the waterproof membrane in the protected roof experiences a much lower variation in temperature tending to increase its service life.

However, adequate attention should be paid to protect the thermal insulation in a "protected membrane roof" against both climatic and mechanical factors. This can be achieved by applying slabs, tiles or ballast on the top of the insulation layer. The insulation layer itself should be capable of withstanding high temperature variations, it should have a good strength to bear loads and it should be impermeable enough not to be affected by moisture.

Although the initial cost of the "protected membrane roof" might be slightly higher than the "warm roof", the recurrent cost of a "protected membrane roof" is usually less than that of a "warm roof". This is because the asphalt in the "warm roof" needs frequent repairs due to its exposure to severe climatic conditions, i.e. high solar intensities and high temperature fluctuations.

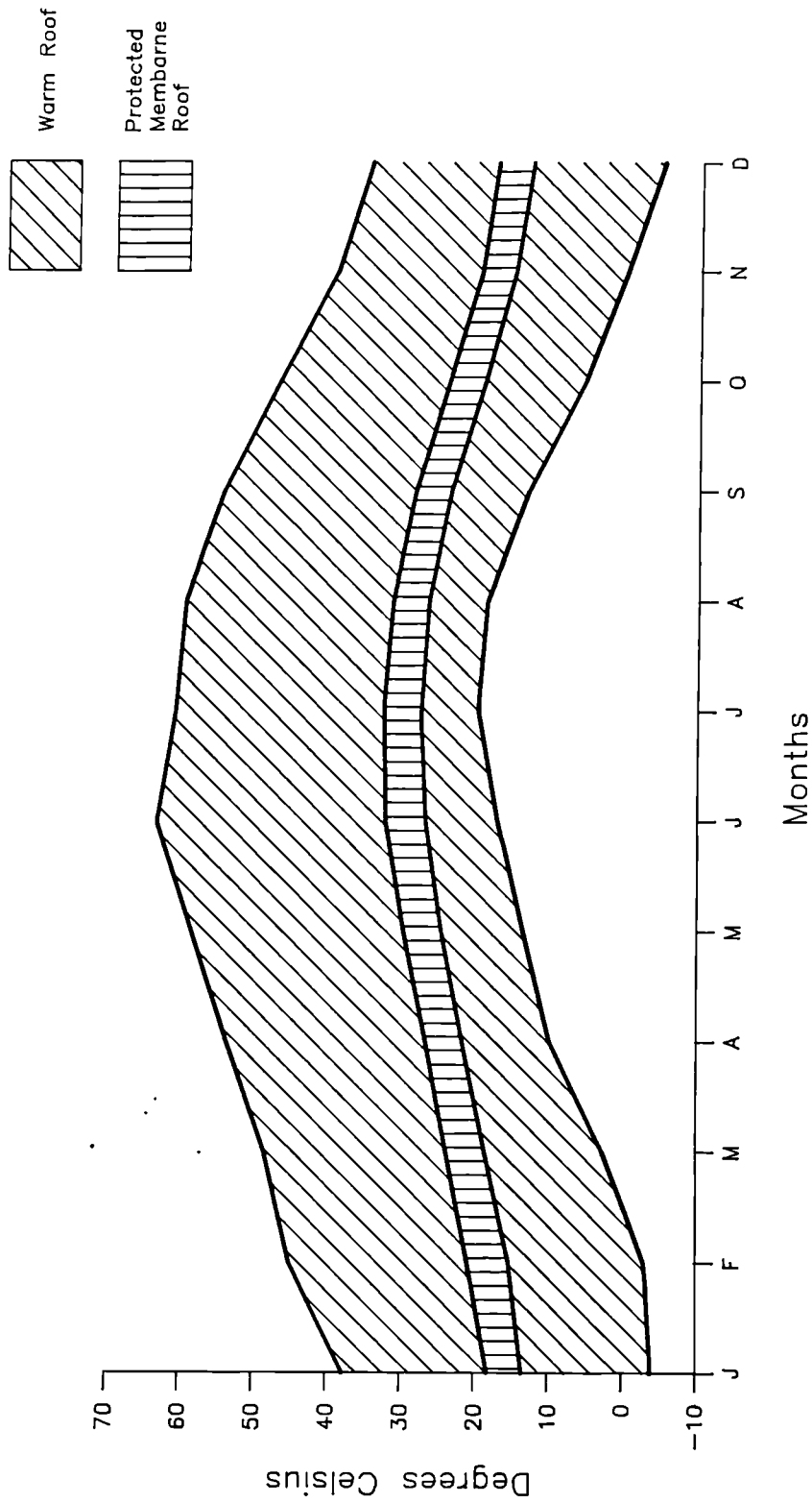

Figure 6.4 Temperature variations in asphalt for the two types of roofs (21st of July)

6.3 THE EFFECT OF COLOUR AND THERMAL RESISTANCE OF ROOFS ON THEIR SURFACE TEMPERATURES

Surface colour and insulation are both considered important factors affecting the waterproof membrane temperature and heat flow through roofs [4]. As the solar energy is absorbed in the roof, the temperature of the roof surface rises until an equilibrium is reached between the rate of heat absorption and dissipation at the surface. The heat is dissipated at the surface of the roof by three processes; conduction to the layers below, convection and radiation to the outdoors. The better the roof is able to dissipate the energy through these three processes, the less the temperature of the roof surface will be. Adding insulation to the roof reduces the amount of heat dissipated into lower layers by conduction. Consequently, a waterproof membrane over insulation will be hotter than if it was placed directly on a deck (see Figure 6.3).

There has been serious concern in the roofing industry that thicker insulation, i.e. a higher thermal resistance may cause extremely high membrane temperatures which could severely shorten the service life of the roof by accelerating deterioration of the asphalt ingredients. Baker [5] stated that temperatures experienced by roofing materials during their service life may well determine the success or failure of a roof system.

The temperatures of the asphalt in uninsulated and insulated roofs were calculated. In the first case, the asphalt was placed directly on the screed and in the latter it was placed on insulating layers

of thicknesses of 25, 50 and 100mm respectively. The calculated temperatures of the asphalt layers having two different solar absorptivities; 0.5 and 0.85, are plotted in figure 6.5.

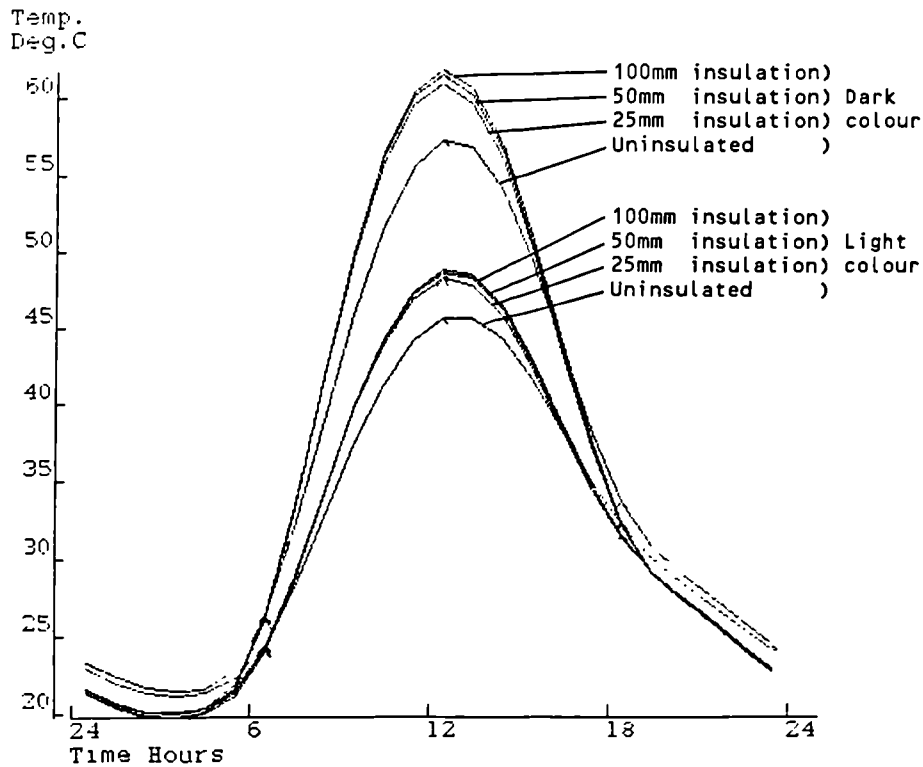

Figure 6.5 The effect of colour and insulation thickness on the roof surface temperatures (21st of July)

It can be seen that the temperature of asphalt increases substantially as the first layer of insulation of a thickness of 25mm placed beneath it. Additional insulation above this amount causes little increase in the surface temperature of asphalt.

The colour distinction has caused a 11.6 °C difference in calculated surface temperatures of the asphalt in uninsulated roofs. The

corresponding difference for insulated roofs having 50mm of insulation material is 12.9 °C.

Since the heat flow through a structure is directly related to its surface temperature, the high roof surface temperatures of dark coloured roofs result in high ceiling temperatures compared with ceiling temperatures of roofs having lower solar absorptances. An example of this has been already shown in figure 4.16 (Chapter 4), in which the ceiling temperatures of dark roofs were found to be higher than those of the light coloured roofs during day and night.

As Givoni [6] explains, the extra heat which has been accumulated in the dark roof during the day has not been dissipated entirely during the night, in spite of the fact that the windows have been kept open at night and nocturnal ventilation of high rates, of the order of 20 ac/h (see Table 1.2 in Chapter 1), have been provided within the internal spaces.

From figure 6.5 one should conclude that roofs in hot climates should be finished in light colours and particularly when the insulating materials are incorporated in their construction.

6.4 THE EFFECT OF COLOUR AND THERMAL RESISTANCE OF ROOFS ON ANNUAL COOLING AND HEATING LOADS

The roof is the most vulnerable building component from the point of view of energy savings. During the summer, the extensive solar

radiation falling on roofs causes high roof surface temperatures (see Figure 4.14, Chapter 4) and consequently heat flow through the roof. In winter, the clear night skies serve as a potential heat sink for the radiative heat loss from the roof. This causes low roof surface temperatures (see Figure 4.15, Chapter 4) and the roof becomes a major route for heat loss.

The effect of roof design on energy requirements was analysed by calculating the annual cooling and heating requirements of the reference house having different roof design specifications (roofs are considered to be of "warm roof" type). Results are illustrated in figure 6.6.

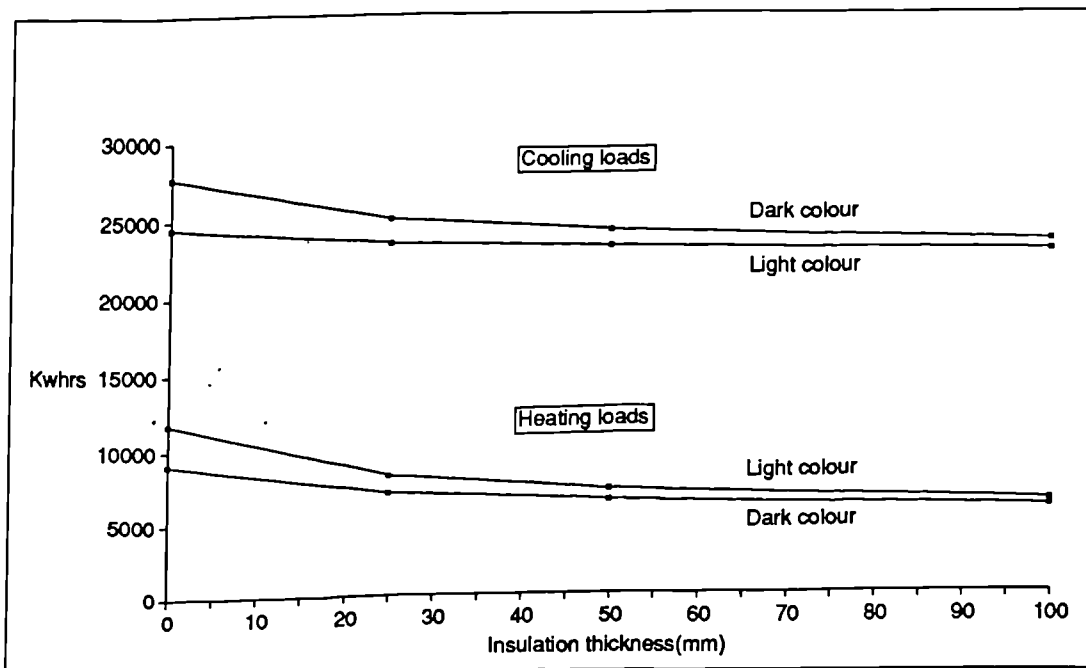

Figure 6.6 The effect of colour and insulation thickness of the roof on the annual energy requirements of the reference house

Changes in the calculated loads due to changing the colour of the roofs from dark to light are presented in figure 6.7. In the case of the uninsulated roof, changing the colour of the roof results in the annual cooling loads being reduced by as much as 3220 Kwhrs. This change increases the heating loads by 2684 Kwhrs. The corresponding changes in loads for the reference house having an insulated roof with 50mm of insulation material are 1073 Kwhrs and 698 Kwhrs respectively. The effect of the colour of the roof on loads diminishes as its thermal resistance increases.

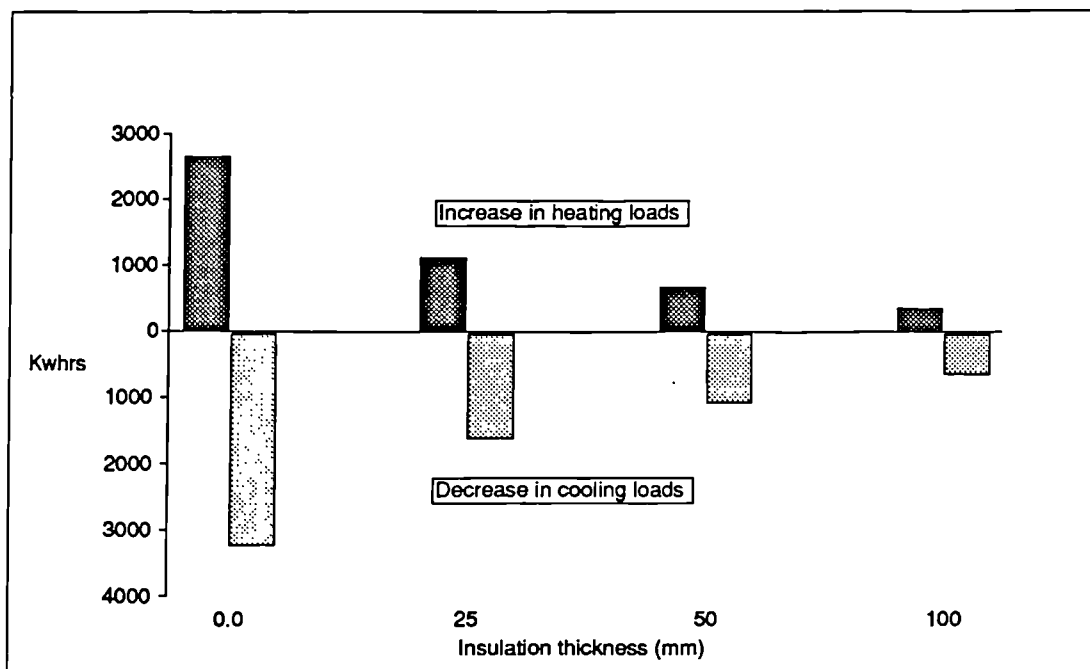

Figure 6.7 Changes in the energy requirements of the reference house due to changing the colour of its roof from dark to light

To analyse the effectiveness of applying insulation to different building components of the reference house in reducing its energy demand, a set of sensitive simulation runs were performed. Table 6.2 compares the potential energy savings due to upgrading the roof and the external walls.

Table 6.2 Reduction in annual loads (Kwhrs/m²) due to applying insulation

Component	Light colour		Dark colour	
	Cooling	Heating	Cooling	Heating
Roof (walls uninsulated)	8.3	22.3	17.8	13.5
Walls (roof insulated)	0.2	16.8	6.7	10.7

The numbers given in table 6.2 show the reduction in annual load per square metre of component area when 50 mm of insulation is incorporated into the design. The walls (south, east, west and north facing) were insulated externally and coated with 19 mm render. The roof is a "warm roof" type. From the table it can be seen that insulating the roof is more effective for saving energy than insulating the walls. The cost of insulating the roof would in general be less than that for the walls which makes insulating the roof the most attractive option.

6.5 ROOF SHADING

In a hot, dry climate, shading from the sun's heat is an effective environmental control measure. Reduction in heat fluxes through roofs in summer can be achieved by obstructing the solar radiation reaching the roof. Shading might be provided by different means, e.g. by pergolas, use of removable canvas, erecting a secondary roof over the main roof, etc.

Shading devices may be light or relatively heavy, depending on the contribution they are required to make to the roof construction; they can be fixed, adjustable or retractable, excluded from view by parapet walls or made manifest as design elements.

Vegetable pergolas can be provided by erecting platforms of wooden or wire mesh structures and allowing certain vegetable plants to creep over them. The thermal performance of the roof can also be controlled by using shades of movable canvas. The purpose in summer is to protect the roof from unwanted solar radiation during the day and to allow heat loss to the atmosphere during the night. But in winter the roof is to be exposed to solar radiation during sunshine hours, while it should be protected from wasteful heat loss to an overcast or night sky. Therefore, whilst in summer the canvas is stretched over the roof during the day and removed during the night, the sequence is reversed in winter. Hay and Yellott [7] proposed the use of movable insulation over the roof with the same operation practice as described for movable canvas.

In an experiment in the reduction of ceiling temperatures of concrete roofs in Sudan, A. M. Ahmad [8] covered a part of a roof with reed panels while the other part was exposed to solar radiation. The reed panels were tied to a bamboo framework secured to a parapet wall 0.2m high. His measurements indicate that except for a 5-hour period, from 04.30 to 09.30 hours, the ceiling temperature below the shaded part is always lower than that below the exposed part of the slab, the difference being 5.1 degrees celsius at the maximum, at 17.30 hours. The minimum ceiling temperature of the shaded roof, occurring in early morning, was about 1 degree higher than that of the unshaded part. This is due to the fact that after sunset the presence of the shading device is a hindrance to heat loss in two ways: it obstructs radiant heat loss by acting as an opaque barrier and obstructs convective heat loss by restricting air movement over the surface.

Nayak et al [9] studied the relative performance of five different approaches to the reduction of heat flux through the flat roof in the hot climate of New Dehli, India. The approaches they examined were; roof shading by plants, use of movable canvas, evaporative cooling, roof garden and use of inverted earthen pots over the roof. They found that shading the roof reduced heat fluxes into living spaces considerably. The performance of shaded roofs with a water film maintained on its top surface was improved due to the evaporative cooling which took place. Though evaporative cooling is an effective measure in hot dry climates for reducing roof temperatures, this method due to its obvious disadvantages, e.g. the shortage of water in the tropics, structural problems which may rise

as the result of the continuous presence of water over the roof, etc. is considered to be of limited general practical value.

To examine the effect of intercepting direct solar radiation reaching the roof, a set of three days simulations were run in the month of July. It was assumed that roofs might be 30%, 60% and 90% shaded respectively during the sun-up periods. Shading was assumed to be distributed evenly. In the simulation runs whose results are reported here, the effect of shading is limited to the interception of the direct solar radiation only. In addition, it has been assumed that heat exchanges by radiation and convection between the roof and outdoors remain unaffected. Two types of roofs were modelled; uninsulated, and insulated having 50mm of insulation material in the form of the "warm roof" type as shown in figure 6.1. Roofs are of the same colour having a solar absorptivity of 0.5.

External surface temperatures of roofs on the 21st of July when there is no obstruction to intercept direct solar radiation together with those when they are shaded were calculated and are plotted in figure 6.8. Shading the roof can significantly reduce the surface temperature of the asphalt. For example, the maximum surface temperature of the asphalt in a well shaded (90% shaded) uninsulated roof is 11.6 °C lower than the corresponding value when it is not shaded. The corresponding difference for the insulated roof is 13.2 °C.

- 1 - Insulated, unshaded
- 2 - Uninsulated, unshaded
- 3 - Insulated, 30% shaded
- 4 - Uninsulated, 30% shaded
- 5 - Insulated, 60% shaded
- 6 - Uninsulated, 60% shaded
- 7 - Insulated, 90% shaded
- 8 - Uninsulated, 90% shaded

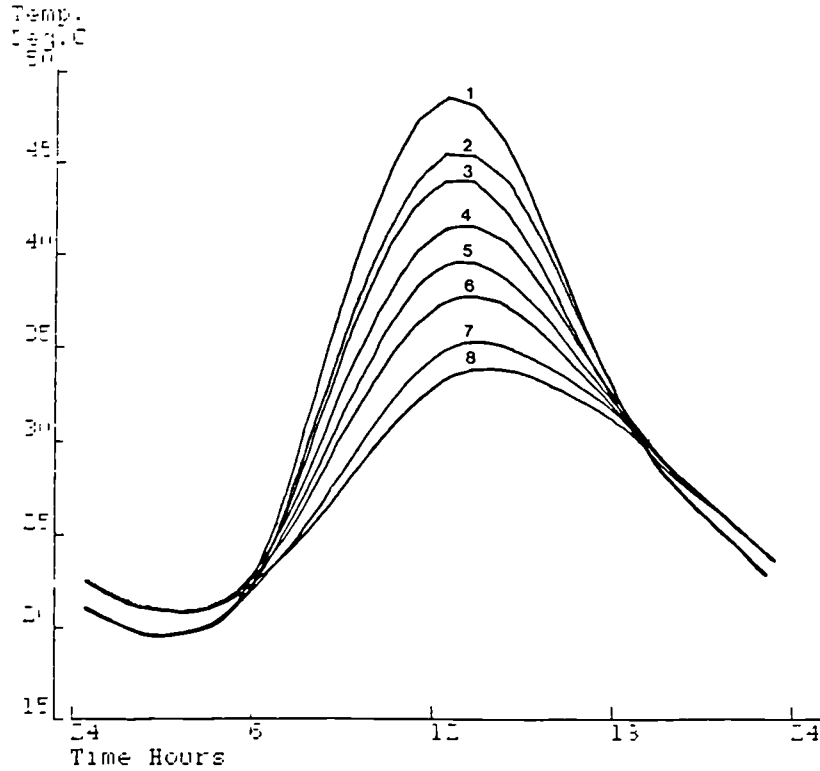

Figure 6.8 The effect of roof shading on the roof surface temperatures (21st of July)

The calculated ceiling temperatures of roofs are plotted in figure 6.9. The ceiling temperatures are reduced as the extent of shadow is increased. Although the insulated roofs experience higher external surface temperatures (Figure 6.8), their average ceiling temperatures are below those of the uninsulated roofs. This is due to the higher thermal resistance of the insulated roofs.

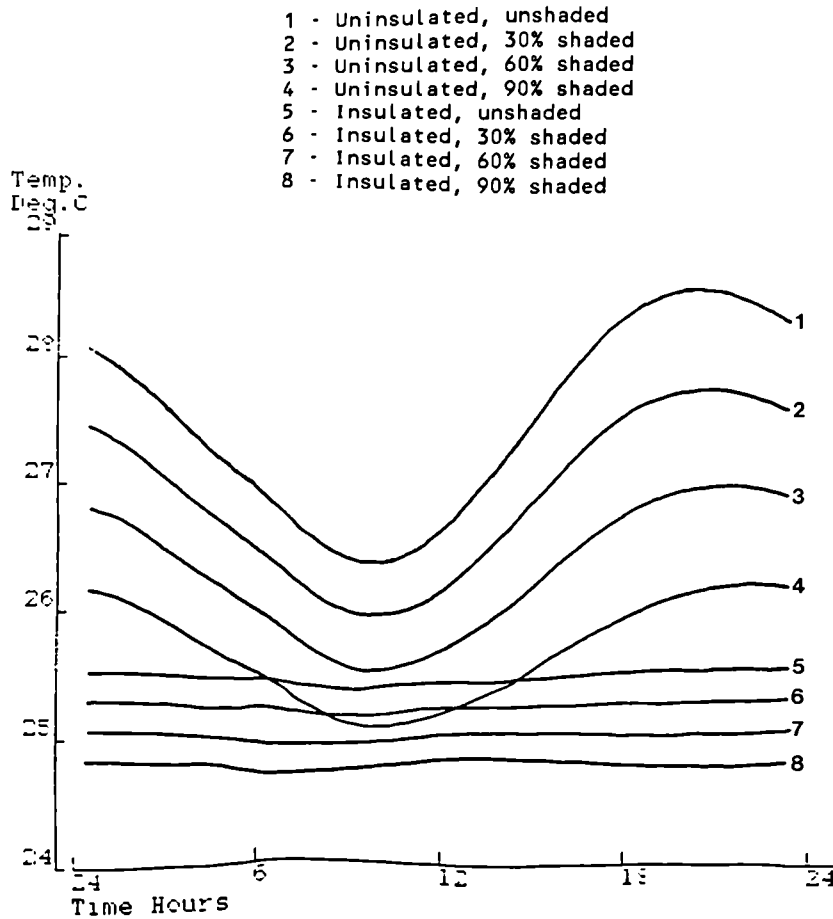

Figure 6.9 The effect of roof shading on the ceiling surface temperatures (21st of July)

The calculated cooling requirements of the reference house during a three days simulation period, from 20th to 21st July, are depicted in figure 6.10. The cooling requirements of the well shaded (90% shaded) uninsulated roof is practically the same as that of the insulated but unshaded roof.

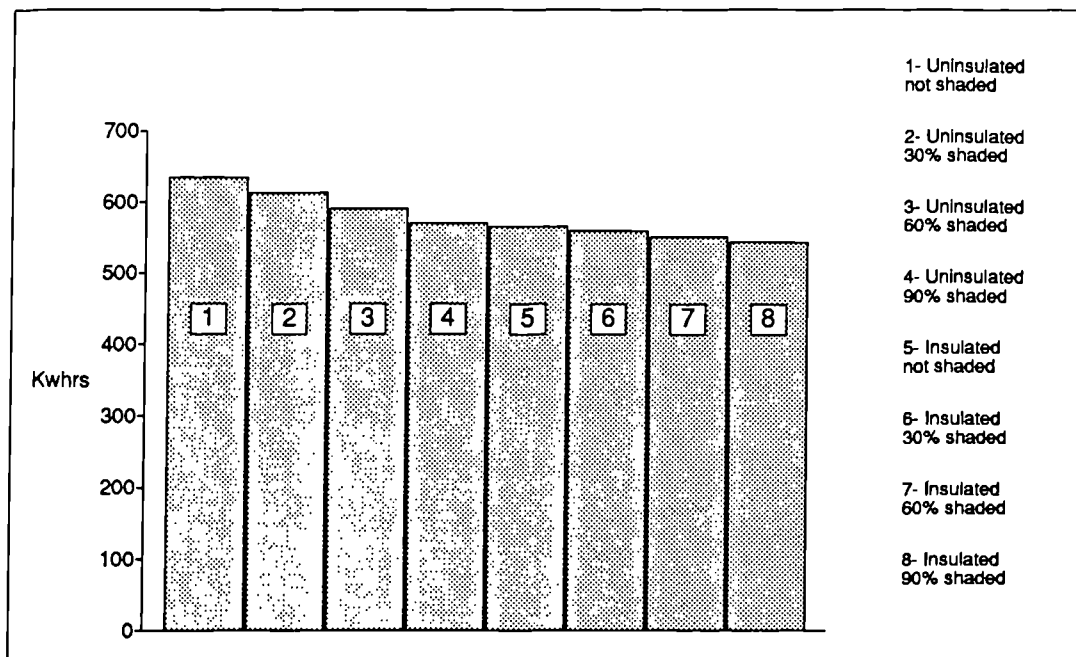

Figure 6.10 Variations in three days cooling requirements (20th to 22nd July) of the reference house due to roof shading

Heat flow through roofs can cause ceiling temperatures well above the room air temperature. For example, as shown in figure 6.9, the ceiling temperature of the (light coloured) uninsulated unshaded roof has become 6.4 °C hotter than the room air temperature (controlled at 22 °C). As mentioned in Chapter 3, one of the cases of asymmetric radiation which may lead to discomfort is the local heating resulting from radiation heat exchange between the human body and adjacent hot surfaces such as hot ceilings. In tropical climates the effects of radiation from ceilings with high temperatures are considered as the main causes of discomfort [10]. In order to attenuate the heat flow through roofs, it is therefore crucial to take appropriate measures such as lowering the solar absorptivity of the roof surface, incorporation of insulation into

the roof design, roof shading, etc. Such measures not only will improve the global energy balance of buildings but will improve their indoor thermal conditions.

6.6 ECONOMIC CONSIDERATIONS

The cooling and heating loads represent the energy that has to be extracted and added respectively and are not energy consumptions. Energy consumptions will depend on the refrigeration system coefficient of performance and the heating system efficiency.

In terms of economics, changes in loads need to be considered with respect to their ultimate impact on purchasing energy. The designer of a house and its ultimate occupier will be concerned with running costs and the cost effectiveness of any modification in the design of the building. Without taking the full steps of estimating savings associated with an investment that occurs over an extended time, an interesting comparison of estimated savings can be made by casting the computed results into current cost savings.

If the annual cooling load is given by L_c (Kwhrs), the heating load L_h (Kwhrs), then the total annual energy requirements, Q_t , is given by:

$$Q_t = L_c/cop + L_h/f \quad (\text{Kwhrs}) \quad (6.1)$$

Where cop is the coefficient of performance of the cooling system

and f the overall efficiency of the heating system. Typically for Iran the cooling system is electricity driven whilst gas is used for heating. If the cost of electricity is C_e per Kwhrs and that of gas C_g per Kwhrs, the total annual cost C_t is given by:

$$C_t = (L_c/cop) * C_e + (L_h/f) * C_g \quad (6.2)$$

This can be written as:

$$C_t/C_g = (L_c/cop) * N + (L_h/f) \quad (6.3)$$

Where N is the ratio of electricity cost to gas cost, C_e/C_g . Values of cop , f and N vary depending on the efficiencies of the refrigeration system, heating system and the local prices of fuels respectively. By assuming that values of cop may vary between 2 and 3, and those of f between 0.6 and 0.8, and N between 3 to 6, different scenarios may be considered. We considered 3 scenarios. In scenario 1 (SC1), we took middle range of variables, i.e. values of 2.5, 0.7 and 4.5 for cop , f and N respectively. By substituting these values in equation 6.3 we will have:

$$C_t/C_g = 1.8 L_c + 1.43 L_h \quad (6.4)$$

Scenario 2 (SC2) was in the favour of heating loads. i.e. values of 2, 0.8 and 6 were chosen for cop , f and N respectively. And finally in scenario 3 (SC3), values of 3, 0.6 and 3 were assigned for cop , f and N respectively. By substituting these values in equation 6.3, we have:

$$C_t/C_g = 3 L_c + 1.25 L_h \quad \text{for SC2} \quad (6.5)$$

and :

$$C_t/C_g = L_c + 1.67 L_h \quad \text{for SC3.} \quad (6.6)$$

The cost effectiveness of design solutions, e.g. changes in roof design now can be cast into values of C_t/C_g designated as Annual Cost Factor ($C_t/C_g = ACF$).

The annual running cost (Annual Cost Factors) of the reference house having different roof design specifications, under different scenarios are given in figure 6.11. Under scenario 1 for example, savings in the annual running cost of the reference house as much as 3.1% may be achieved by changing the colour of its uninsulated roof from dark to light. The corresponding savings for the house having an insulated roof with 50mm of insulation material is 1.8%. Incorporation of 50mm of insulation material in the light coloured roof reduces the annual running cost of the building by 17.3%. The corresponding figure for the house with dark coloured roof is 18.4%.

Since all the components of the reference house except the roof are kept constant, one can argue that changes in loads are mainly due to modifications in roof design. This means that we can recalculate changes in Annual Cost Factors based on per square metre of roof area. Having done so, cost savings and penalties due to changing the colour of the roofs from dark to light are illustrated in figure 6.12.

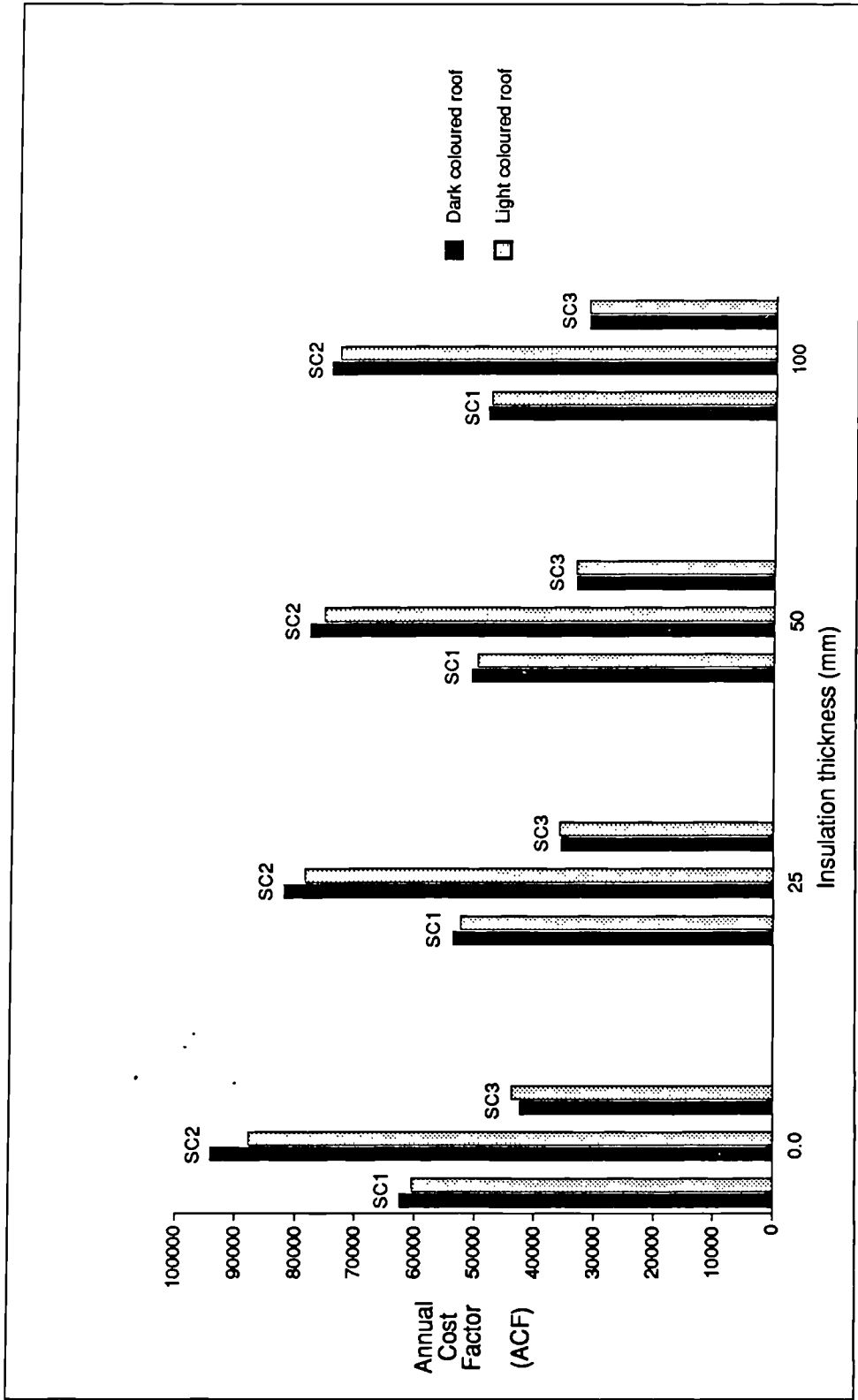

Figure 6.11 Cost analysis for roof design modifications

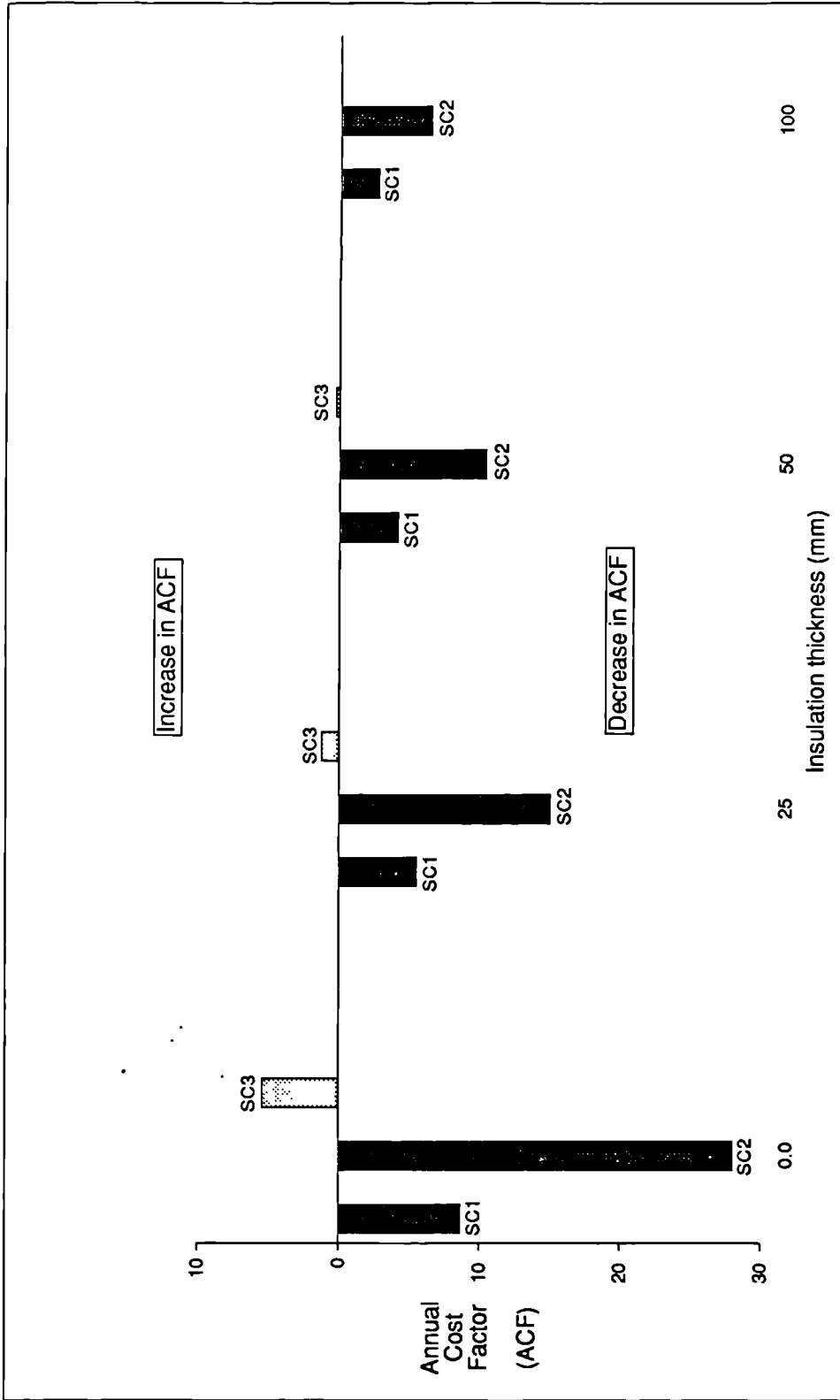

Figure 6.12 Annual cost savings and penalties calculated on the base of per square metre of the roof area due to changing the colour of the roof from dark to light.

Cost penalties due to changing the colour of the roofs from dark to light may only occur when the heating system is very inefficient and/or heating fuel is expensive, i.e. under conditions when scenario 3 applies. Under most normal conditions, considerable savings can be achieved by changing the colour of the roofs. Under scenario 1 for example, about 8.7 ACF (i.e. 8.7 times the cost of purchasing 1 Kwhrs of gas) can be saved per square metre of the uninsulated roof area by lowering its surface absorptivity from 0.85 to 0.5. The proportion of savings diminishes as the thermal resistance of the roof increases. For example, the annual cost savings per square metre of the insulated roof having 50mm insulation is 4.15 ACF as the result of changing its colour from dark to light.

6.7 REFERENCES

- [1] Griggs, E. I. and Courville, G.E. *Changes in building heating and cooling requirements due to a reduction in the roof's solar absorptance*. Proceedings of the ASHRAE/DOE/BTECC Conference on the thermal performance of the exterior envelopes of buildings III, Florida, 1985.
- [2] Property Service Agency (PSA), *Technical guide to flat roofing*. Department of the Environment. U.K., March 1987.
- [3] Kinniburgh, W., *Bitumen coverings for flat roofs*. Building Research establishment, Oversease building notes, No. 180, June 1987.
- [4] Rossiter, W.J. and Mathey, R. G., *Effect of insulation on the surface temperature of roof membranes*. Centre for Building Technology, Institute for Applied Technology, National Bureau of Standards, U.S. Department of Commerce, February 1976.
- [5] Baker, M. C., *Roofs-- Design, Application and Maintenance*. Multiscience Publications, Canada, 1980.

[6] Givoni, B., *The effect of roof construction upon indoor temperatures.* Biometeorology, proceedings of the second international bioclimatological congress, London, september 1960.

[7] Hay, H. R. and Yellott, J. I., *International aspects of air conditioning with movable insulation.* Solar Energy, 12, 1969.

[8] Ahmad, A.M. *The thermal performance of concrete roofs and shading panels under arid summer conditions.* Building Research Establishment, Overseas building notes, No. 164, October 1975.

[9] Nayak, J. K. et al, *The relative performance of different approaches to the passive cooling of roofs.* Building and Environment, Vol. 17, No. 2, 1982.

[10] Mukhtar, Y. A. *An investigation into the thermal performance of roofs in hot dry climates.* Ph.D. thesis, University of Newcastle upon Tyne, 1976.

Chapter 7

THE EFFECT OF WINDOW DESIGN ON THE THERMAL PERFORMANCE OF BUILDINGS

- 7.1 Introduction
- 7.2 Heat transfer and windows
 - 7.2.1 Solar position
 - 7.2.2 Angle of incidence
 - 7.2.3 Thermal properties of glass
- 7.3 Performance analysis of external shading devices
- 7.4 Windows dimensions
- 7.5 Window design and energy requirements
- 7.6 Economic considerations
- 7.7 References

7.1 INTRODUCTION

The choice of fenestration for a building can significantly affect its thermal and visual performances as well as its construction and operating costs. Recently, the role of windows in energy conservation has been given more attention and fenestration design has been a source of particular concern to researchers.

In hot dry climates, where the external environment is severe, windows have a major role in creating a balanced indoor environment. Unlike the traditional design of buildings, contemporary buildings have usually adopted the design practice of the moderate climates, having large areas of glazing. This tends to increase the cooling load in air-conditioned buildings, and overheating risks in uncontrolled buildings.

An architectural artefact like a window, however, has to be not only energy-efficient, but it has to serve many other purposes taking into consideration view, privacy, daylight, etc. Windows are usually the most practical way for the provision of fresh air which is a prerequisite for a habitable environment. In addition, windows are used to lend character or beauty to a facade, or to break up the monotony of a featureless expanse of wall, affecting the aesthetic quality and marketability value of the building.

In order to improve the energy balance of windows to reduce the energy requirements of buildings, there is a large and growing range of window systems. These can be thought of as two types; those that

consist of some treatment of the glass itself which might include reflective and absorptive films or use of multi-layer glazing, e.g. double glazing and those that rely on some other means of reducing energy transfer, generally opaque solar barriers and insulation [1].

Special glasses such as heat reflecting or absorbing, although effective in reducing heat transfer through windows, are expensive and might affect the view due to their colour characteristics and light transmission. Generally, their use is not common in the housing industry. On the other hand, opaque solar barriers, e.g. external shading devices which intercept the solar radiation before it gets to the window, are more feasible in the site under investigation.

To quantify the effect of fenestration on energy use and the cost of controlling buildings, ESP's facilities were used to compare the effect of glazing area, orientation and shading. ESP has been found to include the most comprehensive and thorough treatment of glazing among the most suitable candidate building energy simulation programs for passive design defined in Appendix A, namely; ESP, HTB2 and SERI-RES [2]:

7.2 HEAT TRANSFER AND WINDOWS

As will be discussed later, one variable that has an important influence upon the thermal performance of windows is the angle of incidence determined by the position of the sun relative to the

window. Therefore, the sun's position during the course of the year needs to be known.

7.2.1 SOLAR POSITION

It is usual to express the position of the sun in terms of two angles; solar altitude and solar azimuth angles. The solar altitude angle (a) is a measure of the angular elevation of the sun above the observer relative to the horizon. The solar azimuth angle (z) corresponds to the angle on the horizontal plane between true north and the sun's line of bearing. Figure 7.1 illustrates these angles. For different time of day and year, these angles can be found from various almanacs, can be calculated from astronomical equations or may be determined from solar charts.

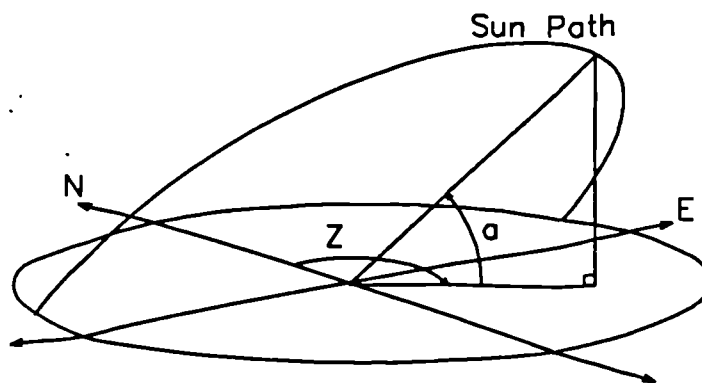

Figure 7.1 Solar position
The azimuth is denoted by (z) and the altitude by (a)

Solar charts are arranged in a form from which it is possible to read off solar altitude and azimuth angles to an accuracy sufficient for design purposes for different latitudes [3]. In this form, they are helpful also in enabling one to visualise the extent of the apparent daily sweep of the sun across the sky. The solar chart corresponding to the site in question in this study, i.e. latitude 32° N, is shown in figure 7.2.

7.2.2 ANGLE OF INCIDENCE

The sun's position in relation to a surface can be determined from the solar altitude and azimuth angles. From figure 7.3, the horizontal component of the angle of incidence (z') will be the difference between the solar azimuth (z) and the wall azimuth. The wall azimuth, which determines the wall orientation, corresponds to the angle on the horizontal plane between true north and the line normal to the wall. Therefore for a wall facing west for example, the azimuth is 270 degrees. The vertical component is the same as solar altitude (a). The angle of incidence (B), i.e. the angle between a line perpendicular to the wall and the sun's direction, can be found by the following equation:

$$\cos B = \cos a * \cos z' \quad (7.1)$$

In the case of transparent material, e.g. glass, the proportion of energy directly transmitted through it, depends on the angle of incidence of the incoming radiation. As the angle of incidence

Figure 7.2 Solar chart of the City of Yazd [4]
 (Latitude 32 North)

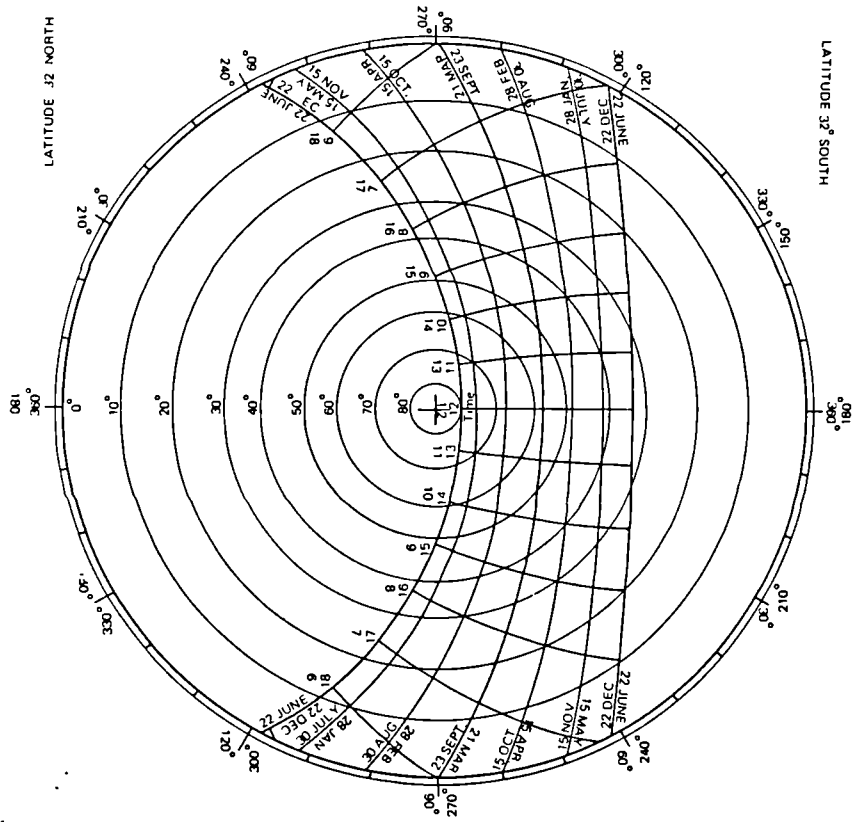

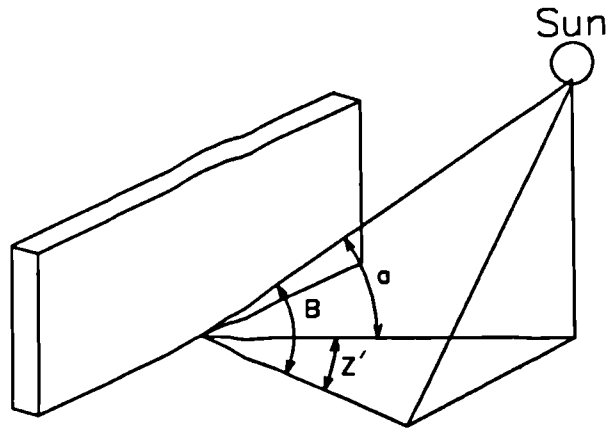

Figure 7.3 The angle of incidence (B)

increases, penetration through the glass drops off sharply. Figure 7.4 shows that the proportion of energy transmitted through clear float glass changes little within angles of incidence from zero to 40 degrees, and then begins to decrease rapidly as the angle of incidence increases towards 90 degrees. This feature is helpful, as it reduces solar gain in summer when the sun is at high altitudes. Total heat gain factor defined in figure 7.4 is the fraction of the incident radiation that is transferred through the glass by direct transmission and by the inward release of absorbed energy. Figure 7.5 shows the relative proportion of reflected, absorbed and transmitted radiation for normal incidence.

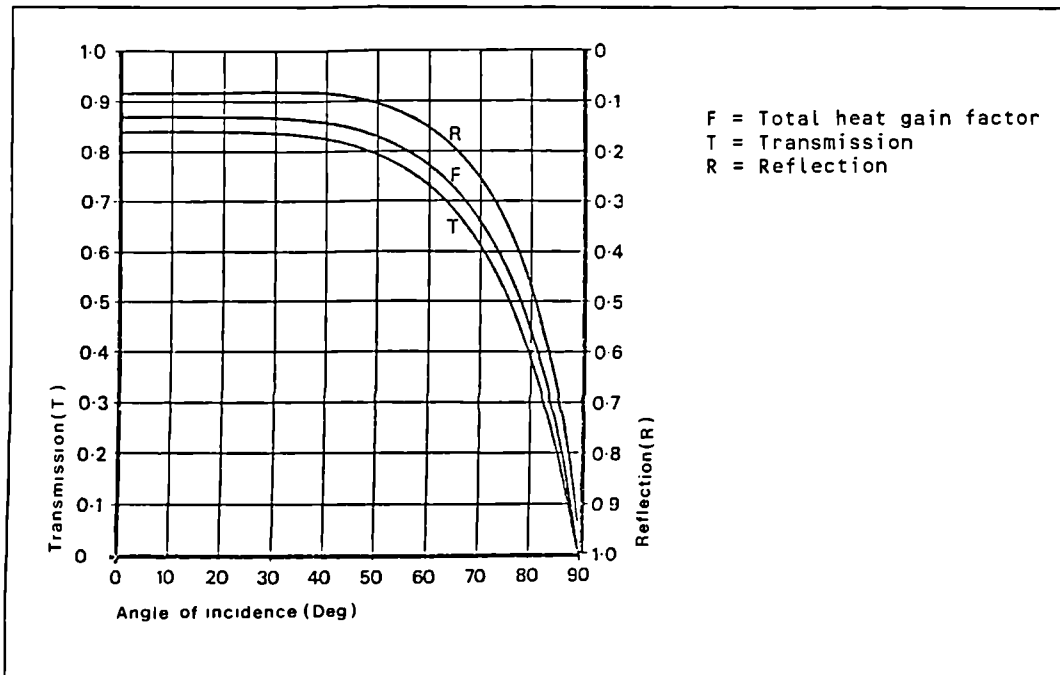

Figure 7.4 Transmission qualities of 4mm clear float glass

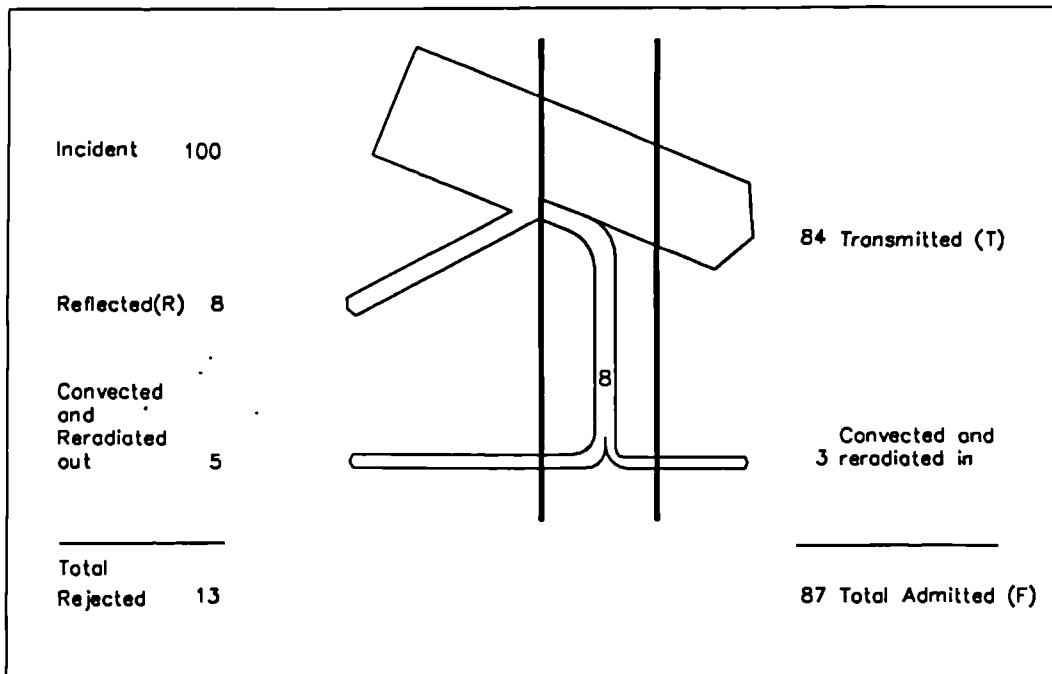

Figure 7.5 Relative proportion of reflected, absorbed and transmitted radiation for 4mm clear float glass for normal incidence

7.2.3 THERMAL PROPERTIES OF GLASS

As mentioned above, when solar radiation meets the glass, a fraction of it passes directly through the glass into the room, a fraction is reflected back into the atmosphere, and the remainder is absorbed (Figure 7.5). The relative proportions of the three components are determined by the angle of incidence of the incoming radiation and the spectral properties of the glass.

The solar energy absorbed by the glass causes an increase in glass temperature until an equilibrium is reached between the rate of heat absorption by the glass and the rate of heat dissipation from the glass by convection and radiation, both into the room and to the outdoors, with the heat storage in the glass remaining constant at equilibrium.

The unique property of glass is the differential transparency to shortwave and longwave radiation. While transmitting most of the radiation in the range 0.4 - 2.5 microns, which approximately coincides with the range of the solar spectrum, glass is opaque to radiation of longer wavelength, around 10 microns [5].

Thus glass transmits radiation in a selective manner, permitting solar radiation to penetrate into the buildings to be absorbed by the internal surfaces and objects and to elevate their temperature. But the heated surfaces emit radiation at peak intensity with a wavelength of about 10 microns and this radiation can not be transmitted outwards through the glass owing to its opaqueness to

this wavelength. This phenomenon is called the "green house" effect.

The absolute and relative transmittance of light and heat differ for different glasses. Glasses used in the building industry can be divided into several types, according to their spectral transmission, absorption and reflection characteristics, the main types being clear, heat absorbing and heat reflective glasses. The first type is the most common in housing industry.

Heat absorbing glasses absorb a relatively large percentage of the incident solar radiation due to a higher content of iron oxide among the ingredient of the glass. This causes the temperature of the glass to rise considerably. The high temperatures reached by these glasses exposed to sunlight can in practice be a serious source of discomfort to the occupants as a result of the effects of directional longwave radiation from the glass [6].

Heat-reflecting glasses are obtained by depositing a very thin metallic coating on the surface of the glass, which reflects selectively a greater proportion of solar radiation. While reflective glasses can be of considerable advantage during the cooling season, they reduce the transmission of solar heat in winter, when the heat would be desirable for distribution within the buildings.

Since special glasses and multi-layer glazing are not consistent with common practice and consequently not feasible in the context in

which the design and use of buildings take place in the site in question, only the performance of window systems employing clear glass is analysed here.

7.3 PERFORMANCE ANALYSIS OF EXTERNAL SHADING DEVICES

Shading is one of the most important design parameters for achieving good in-house climatic conditions in countries with hot dry climates [7]. Solar heat gain through windows is a major factor in increasing cooling loads in temperature controlled buildings and has a great effect on increasing the indoor air temperature and overheating in free-floated buildings. To lessen the impact of solar heat, shaded structures in general and protected windows in particular should be considered.

The protection of structures against solar radiation should be considered in very early stages of design. Planners should consider adequate strategies for providing desirable shading in summer while allowing individual buildings to benefit from solar radiation in winter. Architects should give thoughts to the matter when considering siting, orientation, external features of buildings etc., otherwise, as frequently occurs, the extent and seriousness of direct sunlight penetration may only be fully realised after the building is completed. The means of sun control is then left primarily, or even entirely, to less effective internal devices, such as curtains and venetian or roller blinds.

Shading the glass affects the quantity of incident radiation and hence modifies the heat flow to the interior and ultimately the indoor temperatures. The quantitative modification depends on the size and location of the shading with respects to the glass, whether internal or external. When shading intercepts radiation outside the glass, the temperature of the device increases due to the radiation absorbed into the shading material. Since glass is opaque to longwave radiation, heat flow by convection and radiation from the shade barely affects the glass. Thus only a small fraction of the incident radiation reflected inwards by the shade may penetrate externally shaded glazed areas.

When the shading is internal, in the form of venetian blinds for instance, solar radiation is transmitted through the glass before interception. The radiation absorbed into the shading material is re-released to the interior and almost all of this heat remains within the space as the opaqueness of the glass prevents longwave radiative heat dissipation. Only the radiation reflected outwards from the shading at the original wavelengths is transmitted in part to the exterior which has no internal heating effect. The effectiveness of internal shading devices is therefore limited to the extent to which shortwave radiation is reflected back through the glass, and on the whole is much less effective than the external shades in limiting heat admittance.

Generally, most fixed shading systems are less efficient than controllable shading systems. For example, fixed shading devices may unnecessarily reduce the amount of daylight indoors even when

the sun is not shining on them. As a result, more electrical light may have to be used than with adjustable or operable shades. Fixed shading devices may also obstruct the welcome radiation in cooler periods of the year which contributes to the heating system. On the other hand, controllable shading systems are usually more expensive both from the point of view of capital and maintenance cost. This study is restricted to the effects of fixed external shading devices as they are the most feasible and practical devices.

A convenient way to analyse the performance of external shading devices is the use of the so-called horizontal and vertical shadow angles. The horizontal shadow angle (z') characterises a vertical shading device, and it is the difference between the wall azimuth and solar azimuth beyond which the sun is obstructed. The vertical shadow angle (v) characterises a horizontal shading device and it is measured on a vertical plane normal to the elevation considered. Figure 7.6 shows these two angles for vertical and horizontal shading devices.

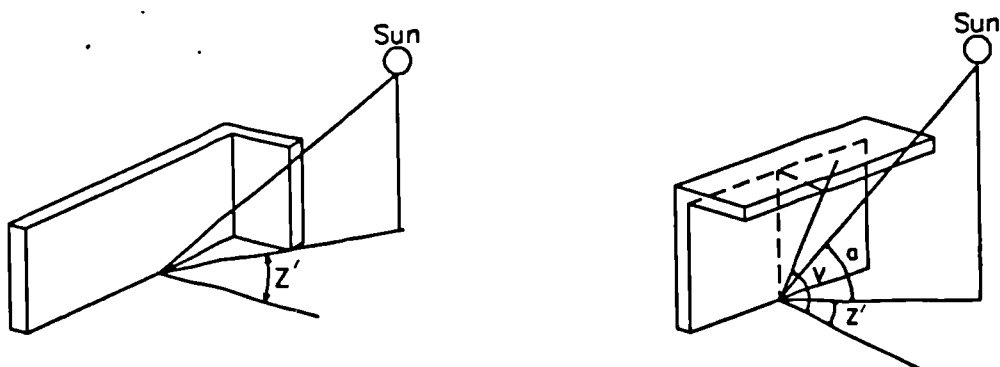

Figure 7.6 Horizontal (z') and vertical (v) shadow angles

By using shadow-angle protractors, figure 7.7, which gives a representation of horizontal and vertical shadow angles, shading masks can be constructed to show the performance of shading devices. The form of the shading mask is determined only by the angular relations and is independent of the actual size of the device. Thus a deep overhang, and a set of small horizontal louvers having the same vertical shadow angle, will have the same shading mask.

In practice the design of shading devices is done in most cases by using graphic sun charts, that allows one to relate the sun path in the sky vault to the geometry of a specific window i.e. orientation and shape.

To evaluate the performance of fixed external shading devices, the method of Olgyay [8] which is widely used by designers was chosen to estimate the size and type of shading devices in the first instance. In the second attempt ESP was used to predict the effect of proposed devices on the annual energy requirements of spaces. Generally, the design of shading devices using the Olgyay method can be carried out in four steps.

In the first step, the time when shading is needed (overheated period) is determined. According to the developers of the method, provision for shading is required at any time when the outdoor air temperature exceeds 21°C (70°F) in regions of latitude of 40 approximately. For every 5 degrees latitude change towards the equator the limiting temperature should be elevated by 0.44°C (0.75°F) for acclimatisation purposes. For the site in question,

Figure 7.7 Shadow angle protractor [4]

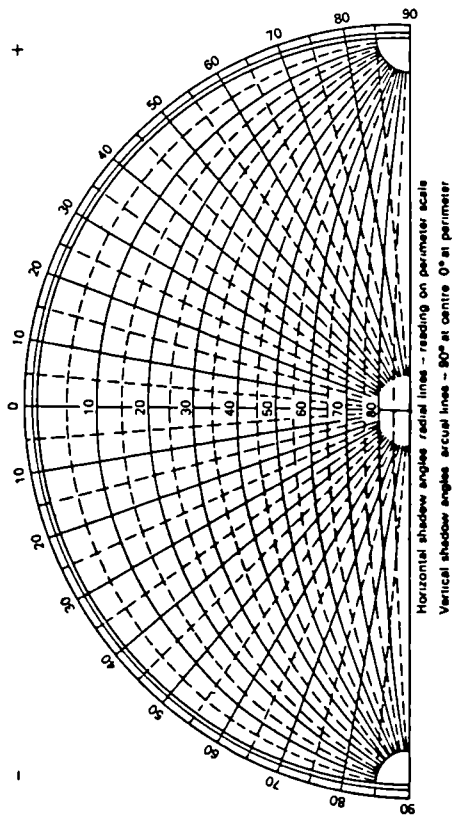

Yazd, with latitude of about 32° N, we considered the limiting temperature for the overheated period to be 22°C . The temperatures which fall over the limiting temperature will define the overheated period, or the times when shading is needed. This can be tabulated on a chart, when the hourly and the monthly divisions serve as ordinates. Having done so, the yearly shading chart of Yazd was constructed and is presented in figure 7.8.

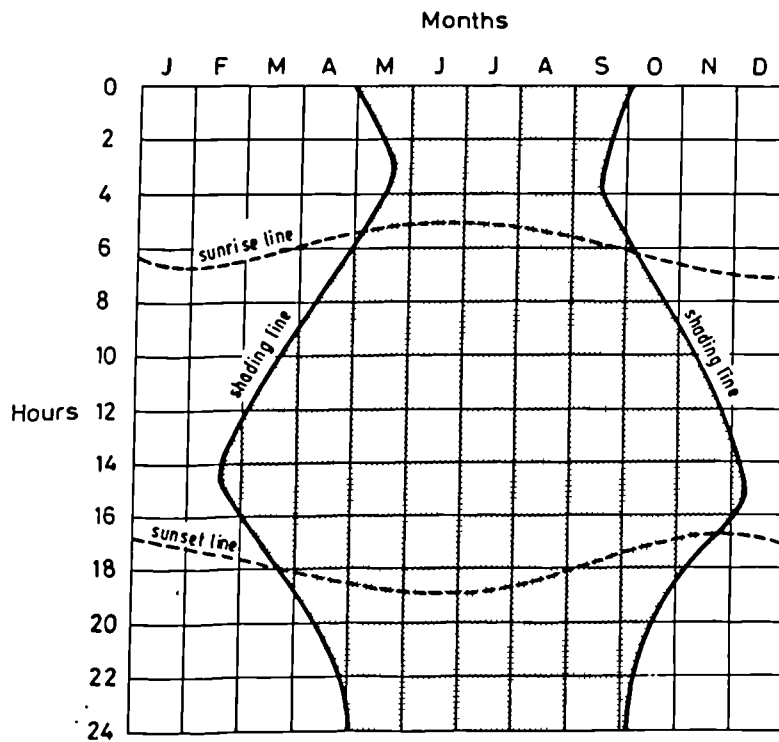
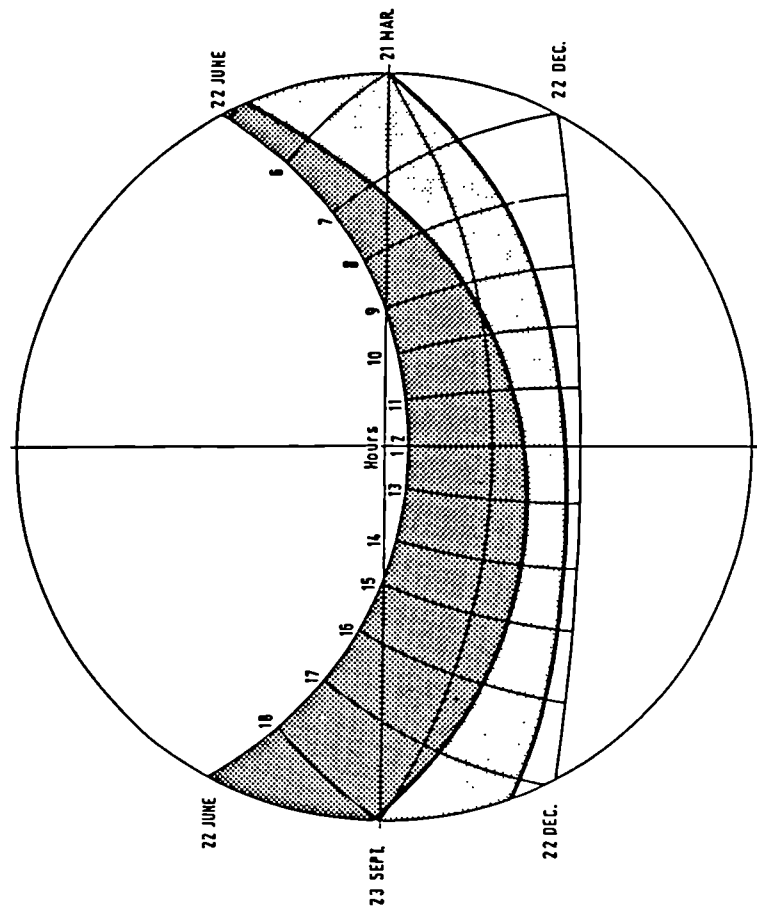

Figure 7.8 Yearly shading chart of the City of Yazd

In the second step, the position of the sun, when shading is needed is determined. This can be done by transferring the overheated period determined in the yearly shading chart to a sun-path diagram corresponding the latitude of the site as shown in figure 7.9.

Figure 7.9 Overheated period transferred from the yearly shading chart (Fig 7.8) to the solar chart



By the nature of the diagram, each line represents two dates when the sun has the same path during the course of the year. The darker area of the overheated period illustrated in figure 7.9 indicates when shading is required on both dates.

Knowing the overheated periods and consequently the times when the penetration of sun into buildings should be intercepted, one can determine the needed shading mask and then find the proper shading device for it.

Any shading device has a characteristic shading mask which defines the performance of the device. Since shading masks are a conventionalised geometric description, they are independent of latitude, orientation and time. Furthermore, they are also independent of the scale of the device. As said before, the performance of shading devices is specified by their angular relation to the facade.

As the third step, the shading masks of shading devices can be constructed. Generally, the shading mask should cover as much as possible of the indicated overheated period while not cover too much of the underheated period, when sunshine is needed for its warm effect. Masks can be drawn for 100 percent shading, in which case the total surface is in shade, and for 50 percent shading, when only half of the surface is in shade. The designers of this method observe that if the 50 percent border of a shading mask covers the outer perimeter of the indicated overheated period area, the shading device should be effective.

In the fourth step, the dimensions of the shading device are determined. This can be easily done using the shadow angle protractor of the same scale as the solar chart.

In figures 7.10 to 7.13, the shadow angle protractor of the same scale of the solar chart is placed on the solar chart with the centre of the protractor directly over the mid-point of the chart. The protractor is then turned about its centre until the base-line assumes the orientation of the exposed wall which it is supposed to present. The 100 and 50 percent shading masks indicated by darker and lighter areas respectively, were superimposed accordingly for four cardinal orientations.

Shading windows facing south is relatively an easy task. The 100 and 50 percent masks presented in figure 7.10. Constructed shading masks define the type and the angle of device only, and possibilities remain for various design arrangements. For example, the shading device for south facing windows of the reference house (window's height = 1.5m) can be an overhang with a depth of 1.26m directly over the window, or can comprise a set of horizontal louvers having a vertical shadow angle of about 50 degrees.

Vertical fins are more effective in intercepting solar radiation falling on windows facing north. A set of vertical fins at a 16 degree angle measured from the wall seem to be satisfactory (Figure 7.11).

Figure 7.10 Shading mask for south facing windows

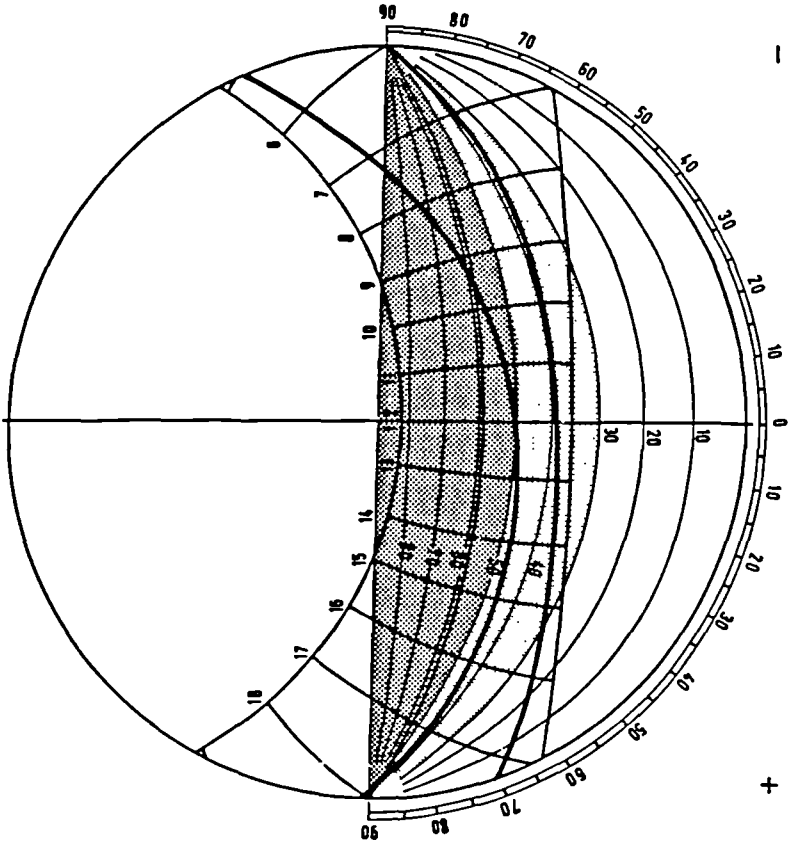

Figure 7.11 Shading mask for north facing windows

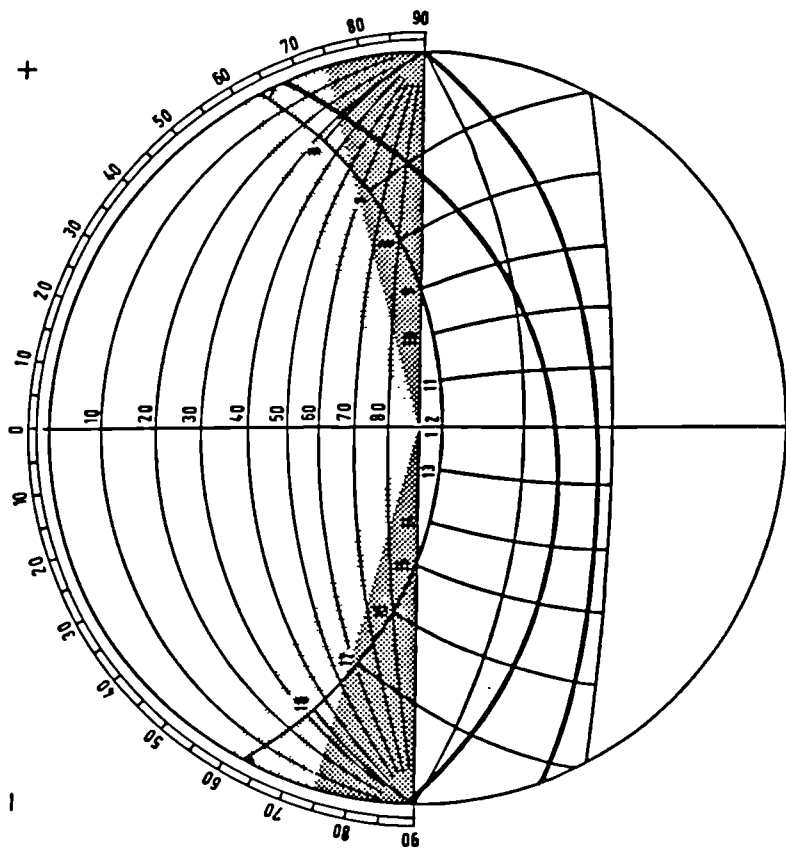

Figure 7.12 Shading mask for east facing windows

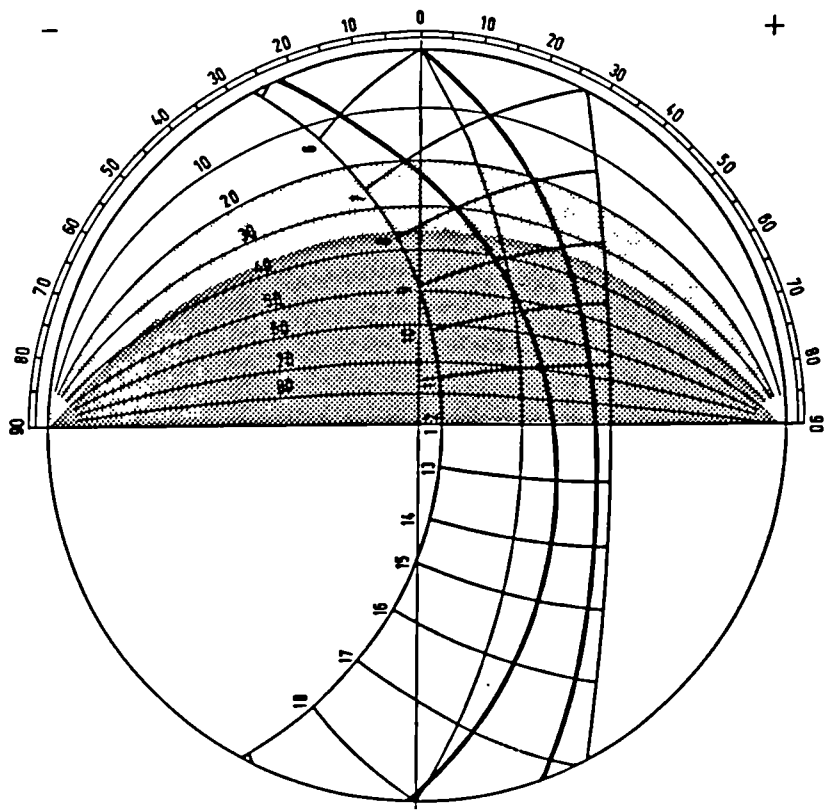
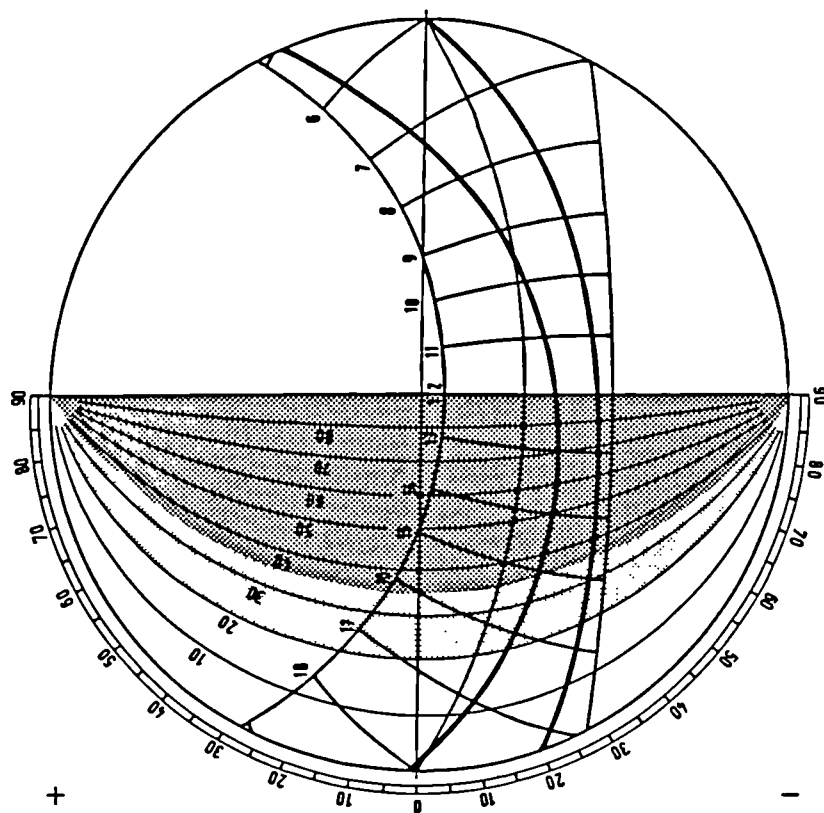

Figure 7.13 Shading mask for west facing windows



Providing adequate shading for east and west orientations is not accomplished as easily as for the other two orientations. Vertical fins provide poor shading in summer, while cutting off almost all radiation in winter. Vertical fins with their members oblique to the south to cut off sun rays are more effective than vertical ones normal to the wall. For rooms facing these orientations it is nearly impossible to intercept the sun rays in summer while allowing its entrance in winter by means of fixed shading devices. Movable shading devices or means of providing seasonal shading, for example by means of deciduous trees planted opposite the wall, could be more effective.

For east and west facing windows, horizontal shading devices having a vertical shadow angle of 35 degrees, for example a horizontal overhang of a depth of 2.15m, whose shading masks are shown in figures 7.12 and 7.13 respectively may be considered.

Figure 7.14 illustrates some possible forms of shading devices whose shading masks were shown in figures 7.10 to 7.13.

7.4 WINDOWS DIMENSIONS

Studies dealing with the psychological reactions associated with windows indicate that to limit the function of windows to the provision of light and air would be erroneous. Other major benefits attributed to windows such as daylight, view, sunshine, privacy, etc. should be considered in design processes in order to create an

Figure 7.14 *Design of shading devices using the Olgyay Method*

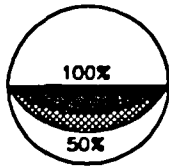

Shading Mask

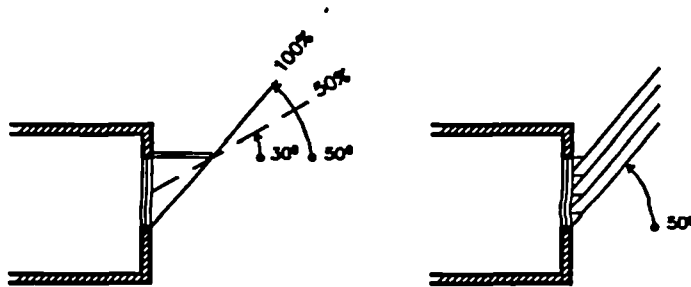

Sections of two possible arrangements of horizontal devices having the same shading characteristics which may be used on the south elevation

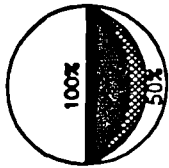

Shading Mask

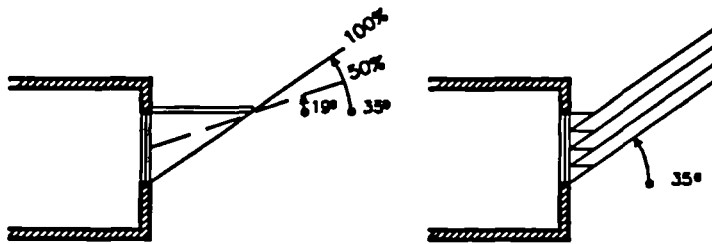

Sections of two possible arrangements of horizontal devices having the same shading characteristics which may be used on the east or west elevations

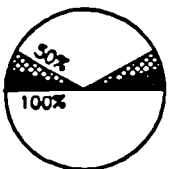

Shading Mask

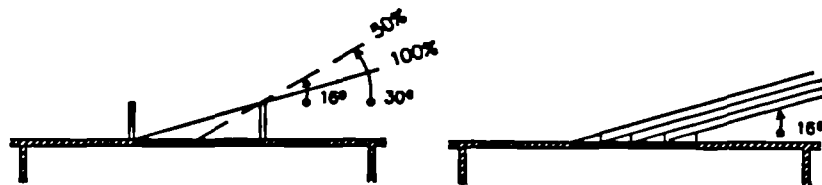

Plan of possible arrangements of vertical fins which may be used on the north elevation.

environment both thermally and visually comfortable to the occupants. The effect of window design on energy requirements would be dealt with later in this chapter. Followings are a brief discussion regarding the psychological reactions associated with window design.

Daylight, the visible part of the global solar radiation, has always been used as the major light source to illuminate building interiors. The aim of good interior daylighting is to provide an adequate quantity of light for the tasks involved, with satisfactory distribution of brightness to give freedom from visual discomfort. The fundamentals of good lighting apply in tropical conditions as elsewhere [9].

Generally, for design purposes two main climatic patterns for daylight calculation have been defined, i.e. the overcast sky and the clear sky.

Hot dry climates are characterised by continuous sunshine from cloudless skies. Thus, direct sunlight as well as skylight should be considered. Another source of interior light will be that reflected off the ground, and from buildings opposite. This component of illumination can increase considerably the amount of daylight indoors. In some cases, with bright ground and surroundings, the external reflected component can reach as much as 50% of the overall daylight received [10].

Where the chief concern in controlling solar penetration lies with

the elimination of solar heat during the hot seasons, as is invariably the case in hot arid zones, as mentioned before the most effective means of control is to block the direct rays from the sun before they can pass through the glazed areas.

Therefore, if the sun is excluded from an interior, the principal source of interior light will be that reflected off the ground, and from objects nearby. The dry light-coloured ground, and the white or light coloured buildings characteristic of these areas do, however, result in surfaces of very high luminance due to reflected sunlight. The reflected light from these sources is usually of such high level that special measures have to be taken to screen the ground and opposing facades from the view of the occupants of a building. Arranging buildings around shaded courtyards, the luminances of which can be controlled by the use of vegetation is of good advantage. Placing windows very high, with the sill above eye level is useful as well but might be less acceptable because of the lack of view. Making use of devices such as louvers, woven fabrics etc., e.g. in the form of protected windows known as "Mashrabias", is also to some advantage.

The fact that a greater proportion of light flux is more likely to enter a room from below the horizontal plane if external sun control devices, e.g. overhangs, are used is important in daylighting design. A large number of human tasks require downward illumination on horizontal surfaces. This can be provided by employing internal surfaces of high reflectances and taking advantage of the high proportion of the incident flux received on the ceiling and upper

section of walls in the room as externally reflected light coming from the ground and opposing facades.

Desire for sunshine is related to the prevalent climate to a high extent. This desire may be strongest for residents of northern latitudes where the duration of sunshine can be quite limited. In hot climates with an abundance of sunshine, people tend to avoid sunshine in their buildings in hot periods of the year because of its excessive heat. But in winter, they welcome some sun in their buildings because it gives rise to a pleasant reaction. This tends to contribute to the heating system reducing heating loads. This desire is so strong that in traditional houses in hot arid zone of Iran, houses had usually two parts, the summer part and the winter part. While the summer part was oriented towards north to be protected from summer sun, the winter part of the house was oriented towards south to catch as much solar radiation as possible.

To achieve an energy efficient design, therefore, the aim should be to maximise solar gain when it is wanted and to exclude it when it is not. In this respect, factors such as orientation, the positioning of openings in external walls, depth of the reveals, the placing of structural projections, e.g. balconies, overhangs, sunbreak walls, canopies, etc. and means of landscaping all should be considered in the planning and design stages.

Another parameter that must be considered in window design is that of privacy. Windows express social relationship, since through them one may see others and be seen. The significance of the concept of

privacy tends to change in various cultures, the types of buildings and the task involved .

Markus [11], identified three elements which affect the perception of visual privacy, 1; the nature of the personal relationships between the observer and observed, 2; the frequency or predictability of the interruption to privacy and 3; the nature of the observed activity.

Positioning a window in residential buildings so that it is easy for people to look in and observe the behaviour of the inhabitants is usually undesirable. In some situations, such as ground level rooms, the desire for privacy may overcome the desire for a view so that people might prefer a smaller window with a less extensive view but more privacy.

The maintenance of visual privacy is of prime importance in house design in the context of islamic culture. It is recommended that windows open to public spaces, e.g. streets, should be protected to provide house privacy so that people can not observe the family activities. In the traditional architecture, rooms are usually oriented to the inner courtyards. This provides a high level of privacy desirable by the inhabitants. Protected windows known as "Mashrabias" were helpful as they not only filtered the light and controlled the glare, but let people to see through them without being seen. However, today's outward oriented rapidly developed buildings have not been able to find a reasonable solution to this problem [12].

Although reducing window size seems to be the easiest way to control solar heat gain and to maintain visual privacy, if too small, windows may no longer provide adequate daylight or a good view out. Very small windows can create annoying glare spots through contrast with the darker surrounding walls [13]. Splayed reveals, to some extent, can reduce the glare of small windows by graduation of brightness.

There are indications that there are window sizes which are too small to satisfy the visual comfort of the occupants. If a recommendation is to be made (provided visual privacy can be satisfied), it would be that windows should occupy at least 20% of the wall area [14,15,16]. People also tend to prefer wide windows than tall windows [14,17].

7.5 WINDOW DESIGN AND ENERGY REQUIREMENTS

In order to investigate the effect of different window systems on the thermal performance of buildings, the energy requirements of four rooms of the reference house facing four cardinal orientations namely; south, north, east and west were examined in the first instance. Different areas of glazing were obtained by changing the window width whilst keeping the height at a constant 1.5 metres. Changing the width from 1 to 5 metres in increments of 1 metre gives window to wall ratios of 10, 20, 30, 40 and 50 percent respectively. Figure 7.15 shows the arrangement of windows on the facade of rooms.

Figure 7.15 Different window arrangements

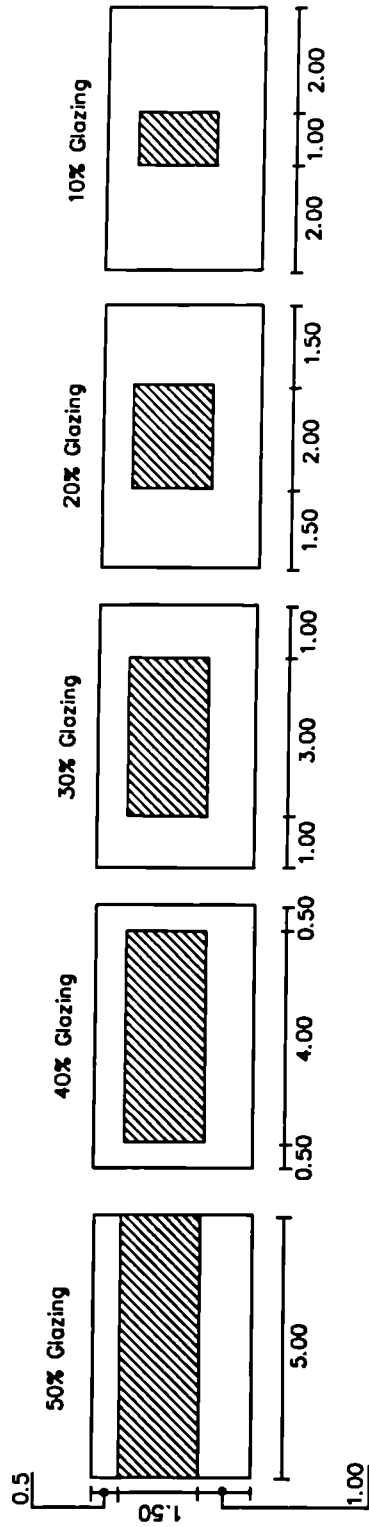

Internal partitions were considered to be surrounded by identical zones, with no heat flow through them. The roof is a "warm type" roof whose design specification is similar to that shown in figure 6.1 (Chapter 6). Construction details of the floor, external walls and partitions are the same as those shown in table 6.1 (Chapter 6). Control strategies are the same for four rooms and as those for intermittent operations given in Chapter 1. The glass chosen is a single pane of 4mm clear float which is the most common and available glass used in the housing industry.

Shading devices over windows may cast some shadow on adjacent structures depending on the extent they are projected. In the simulations whose results are reported here, it was imposed that the shadow of the devices would fall only on the glazing and not on adjacent components. This can be for example the case of small devices in the form of external louvers, etc. This assumption was made in order to keep the heat flow through the walls as much as possible the same in rooms with and without window shading devices.

Furthermore, the effect of shading devices is limited to intercepting the direct solar radiation only. Therefore, any other heat exchanges which might take place between shading devices and windows, i.e. by radiation, convection, or between the device and the opaque fabric, are neglected.

The calculated annual cooling and heating requirements of rooms having different window systems are plotted in figures 7.16 to 7.19.

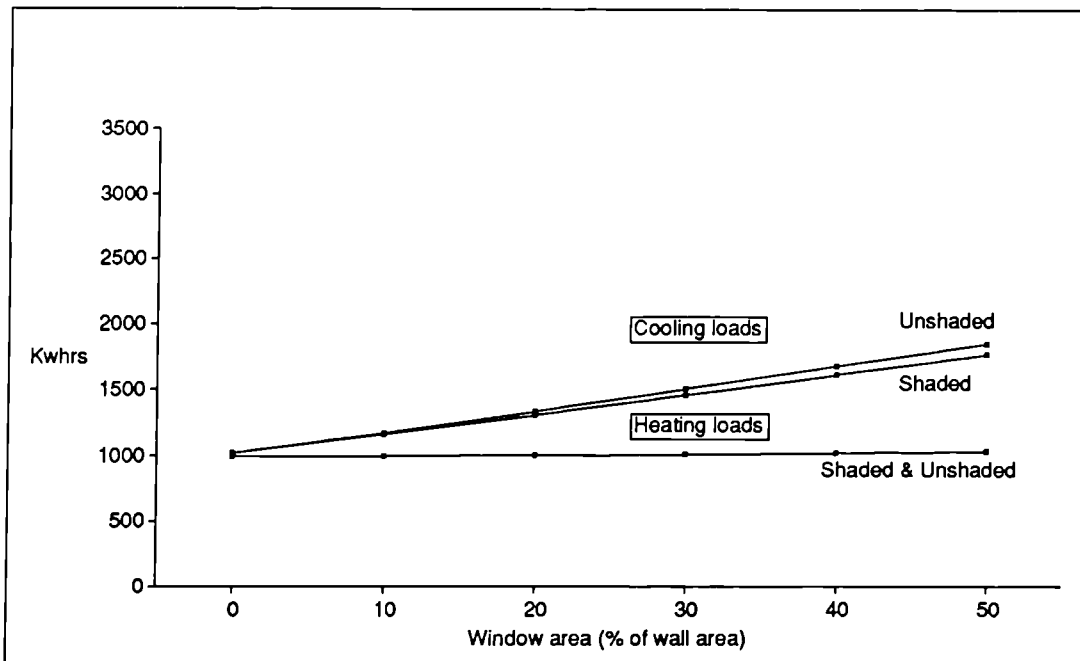

Figure 7.16 The effect of window size and shading on the cooling and heating requirements of the north facing room

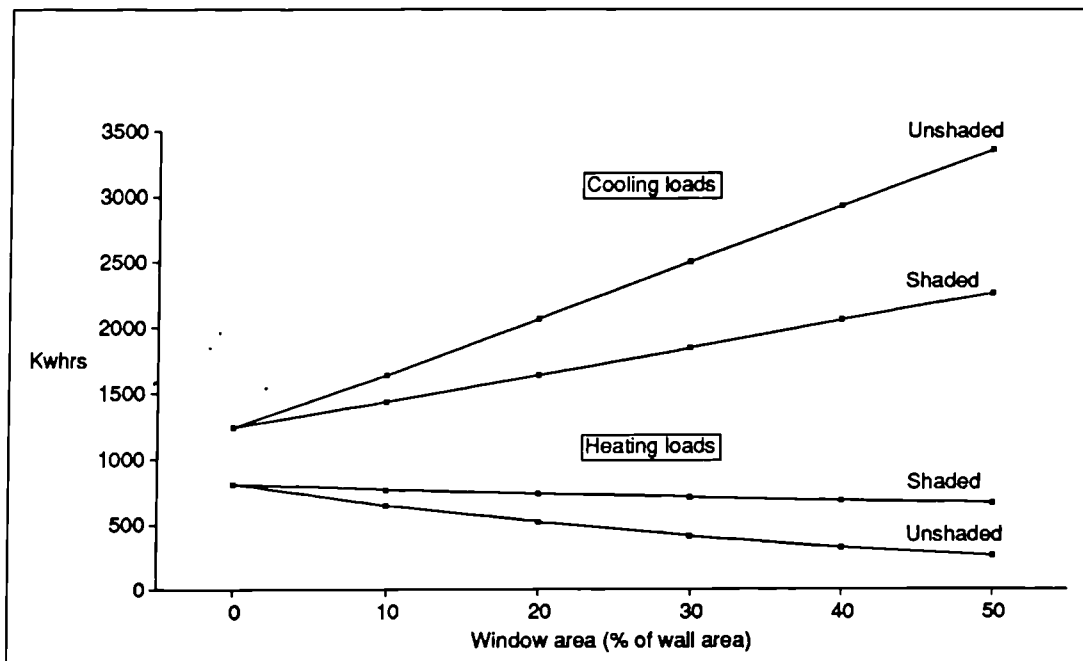

Figure 7.17 The effect of window size and shading on the cooling and heating requirements of the east facing room

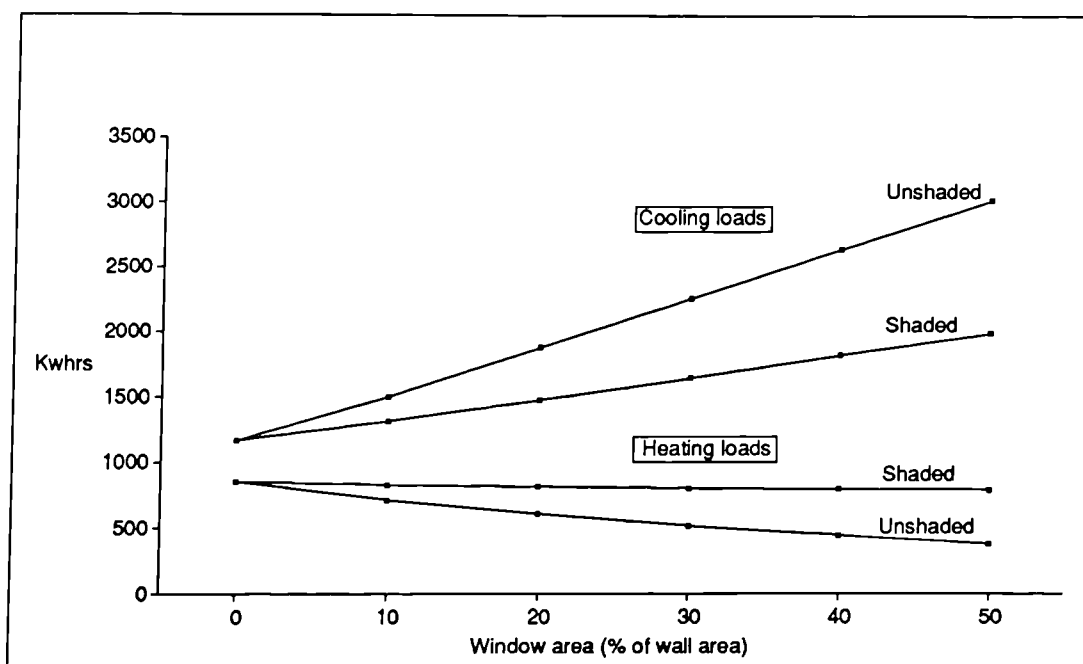

Figure 7.18 The effect of window size and shading on the cooling and heating requirements of the west facing room

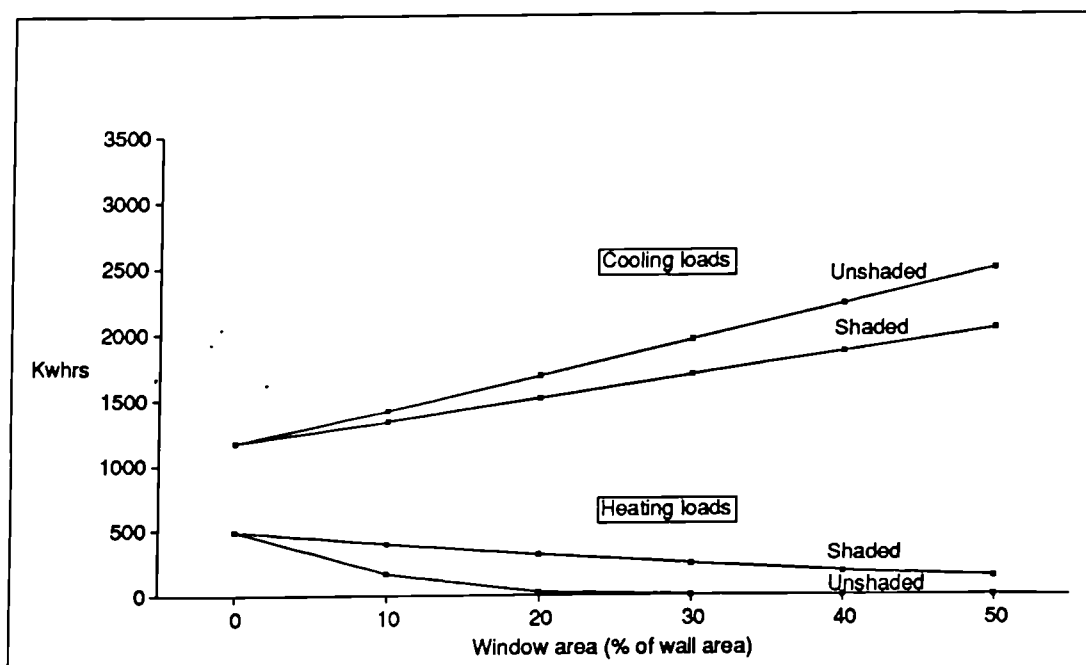

Figure 7.19 The effect of window size and shading on the cooling and heating requirements of the south facing room

As mentioned in Chapter 5, the energy balance of glazing (the difference between the rate of heat gain and loss through the glazing area) indicates whether the glazing would increase or reduce the energy demand of an enclosure over a given period. The trend in the annual cooling requirements of the rooms whose energy demands are shown in figures 7.16 to 7.19 reveals that regardless of the orientation of the rooms there are energy penalties associated with windows. Put another way, over the cooling season the value of the energy balance of glazing has a positive sign, i.e.;

$$|\text{heat gain through glass}| - |\text{heat loss through glass}| > 0$$

Examinations of figures 7.16 to 7.19 also reveals that increasing the window areas reduces the heating requirements in all orientations (because of the useful heat content of the solar energy that larger areas of glazing can transmit indoors) except north. Since at latitude 32° N, windows facing north do not receive any sunshine during the entire heating season, larger windows slightly increases the heating demand of the north facing rooms over the heating period.

The relative performance of shading devices depends on the orientation of the window. As the north facing windows do not receive a great quantity of direct solar radiation throughout the cooling season, the influence of shading devices in reducing cooling loads is not of great significance (Figure 7.16). In contrast, shading windows facing east and west orientations is a very effective environmental control means for reducing the cooling requirements.

As shading devices obstruct some of the winter sun's rays and consequently reduce the useful heat content of the solar energy, heating loads are increased as the result of the incorporation of shading devices in the design.

For the purpose of a better comparison, figure 7.20 has been constructed using data given in figures 7.16 to 7.19. Table 7.1 lists the ratios of the energy requirements of different rooms having different window systems when compared with the windowless rooms of the same orientation.

The potential energy savings and penalties associated with the window design can be assessed by comparing the numbers given in table 7.1. Increasing the area of unshaded windows would considerably increase the cooling loads. For example, the cooling requirements of the east facing room having a window comprising 50% of its wall area is 2.7 times greater than that of the windowless room of the same orientation. Or, increasing the window area of the east facing room from 20 to 50% would result in an increase in the cooling load by 63% $((2.7/1.66) 100\%)$.

The percentage increases in the cooling loads as the result of increasing the glazing areas would be smaller when shading devices are incorporated into the design. For example, the cooling requirements of the east facing room would increase by 38 % $((1.82/1.32)100\%)$ when the area of the shaded window increases from 20 to 50% of the wall area.

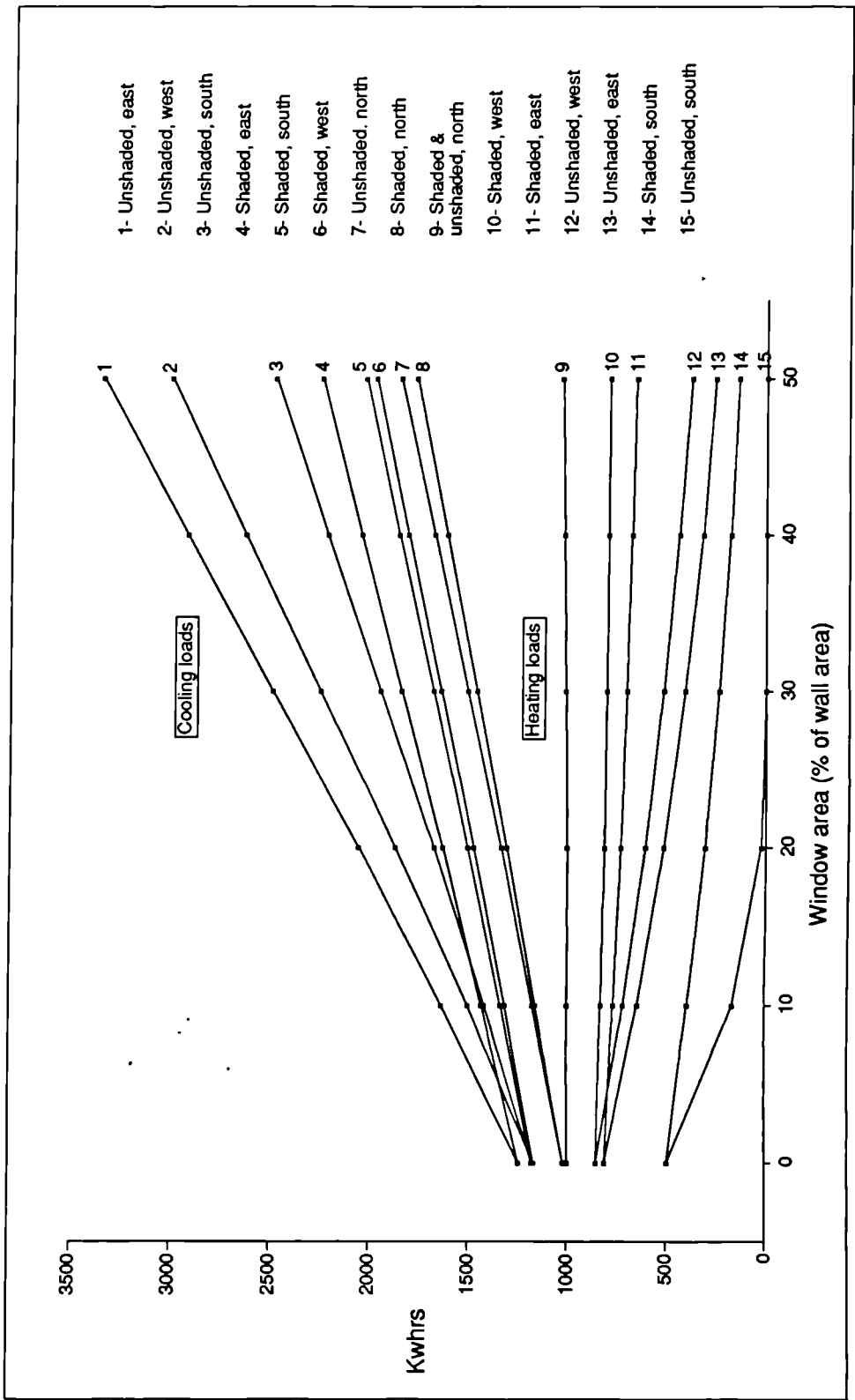

Figure 7.20 The effect of window size and shading on loads

Table 7.1 The effects of window design and orientation on the annual energy requirements of rooms

Orientation	Load	Shading	Window area (% of wall area)					
			0	10	20	30	40	50
NORTH	C	Yes	1.00	1.14	1.29	1.44	1.59	1.75
		No	1.00	1.15	1.32	1.48	1.65	1.82
	H	Yes	1.00	1.00	1.01	1.02	1.03	1.04
		No	1.00	1.00	1.01	1.02	1.03	1.04
SOUTH	C	Yes	1.00	1.14	1.29	1.43	1.58	1.73
		No	1.00	1.21	1.43	1.66	1.89	2.12
	H	Yes	1.00	0.80	0.62	0.48	0.36	0.28
		No	1.00	0.33	0.05	0.00	0.00	0.00
EAST	C	Yes	1.00	1.16	1.32	1.48	1.65	1.82
		No	1.00	1.32	1.66	2.01	2.36	2.70
	H	Yes	1.00	0.95	0.91	0.87	0.84	0.81
		No	1.00	0.80	0.64	0.51	0.40	0.32
WEST	C	Yes	1.00	1.13	1.30	1.41	1.56	1.70
		No	1.00	1.29	1.61	1.94	2.27	2.60
	H	Yes	1.00	0.97	0.96	0.94	0.94	0.93
		No	1.00	0.84	0.71	0.61	0.52	0.45

C = cooling load
H = heating load

From the numbers given in table 7.1, one can also calculate the effect of incorporating shading devices into the design of windows on the energy requirements of rooms. For example, the cooling requirements of the east facing room with a window comprising 20% of its wall area would be decreased by 20% $((1 - 1.32/1.66)100\%)$ as the result of the effect of the shading device in intercepting the passage of direct solar radiation into the room.

7.6 ECONOMIC CONSIDERATIONS

As discussed before, the effect of design solutions on energy requirements may be cast into the cost of purchasing energy to provide more realistic performance determinants. As an example, figure 7.21 has been constructed assuming the conditions of Scenario 1 apply, i.e. using equation 6.4 given in Chapter 6. South orientation is the optimal orientation under the conditions set. Unobstructed windows comprising up to about 25% of the south facing wall, appear to be more efficient in energy terms than those incorporating shading devices designed using the Olgyay method. At other orientations, small shaded windows are preferable. Shading north facing windows seems to reveal no significant savings.

The differences between the Annual Cost Factors of rooms with that of windowless rooms of the same orientation reveal that except for the room facing south, having an unshaded window comprising 10% of its wall area, the presence of windows is associated with cost penalties (Figure 7.21).

The efficiency of shading devices depends on their ability to intercept solar radiation as much as possible in summer while allowing its entrance into the building in winter. To investigate the accuracy of graphical methods in determining the size of devices, the thermal performance of devices of other dimensions was analysed. Some selective results are quoted in the following paragraphs.

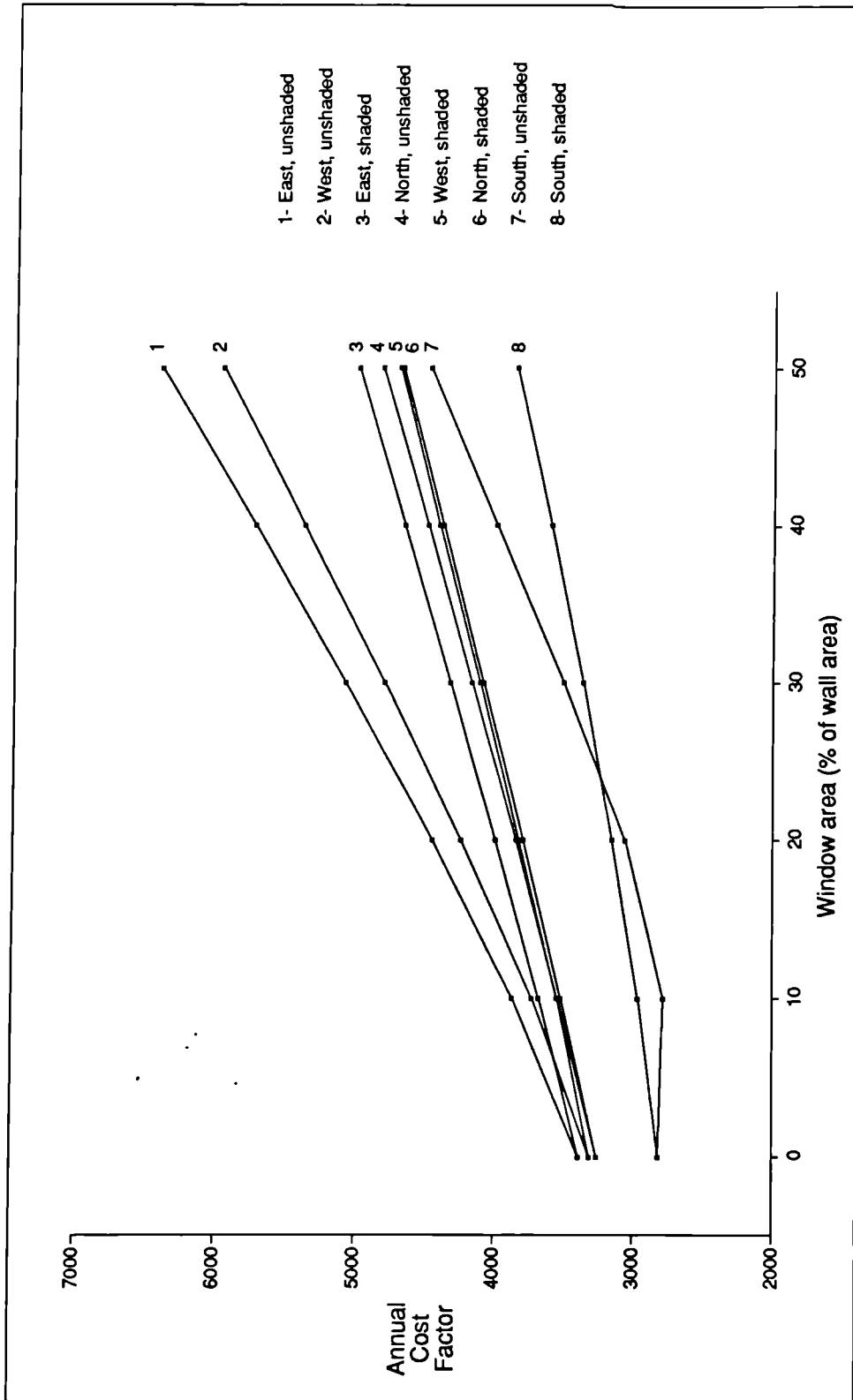

Figure 7.21 Fenestration cost analysis assuming Scenario 1 applies
 (cop = 2.5, f = 0.7, N = 4.5)

Annual cooling and heating requirements of the south and east facing zones under a series of different window arrangements are shown in figures 7.22 and 7.23. Shading devices of different size (note that shading devices designed using the Olgyay Method have vertical shadow angles of 50 and 35 degrees for south and east orientations respectively) were incorporated in the design of windows comprising 20% and 50% of the wall area. The former percentage gives an appropriate window size to satisfy view and be reasonably efficient in energy terms. The latter reflects recent trends in current domestic architecture.

In the case of the south facing room, the cooling loads are practically the same for devices having shadow angles greater than 60 degrees, e.g. overhangs deeper than 0.90 metre (Figure 7.22). Extensive shading devices over windows facing east, however, keeps reducing the cooling loads with a diminishing effect (Figure 7.23). On both orientations, larger shading devices tend to increase heating loads since they obstruct the winter sun to higher extents.

By applying equations 6.4, 6.5 and 6.6 developed in Chapter 6, calculated Annual Cost Factors under different scenarios are plotted in figures 7.24 and 7.25. From figure 7.24, showing the effect of the size of shading devices incorporated in the design of south facing windows, one can find the optimal size of the device by choosing a scenario representing the nearest conditions. Using the Olgyay Method, the estimated shadow angle of the device determined to be 50 degrees. Figure 7.24 indicates that this is overestimated under any scenario.

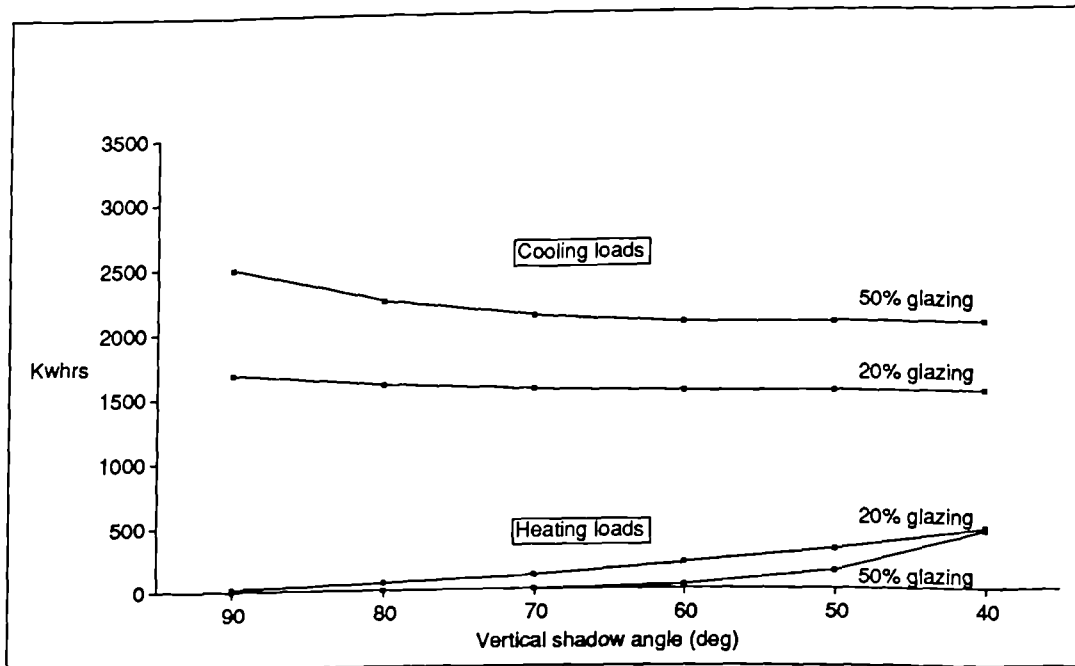

Figure 7.22 The effect of the size of the shading device on the annual cooling and heating requirements of the south facing room

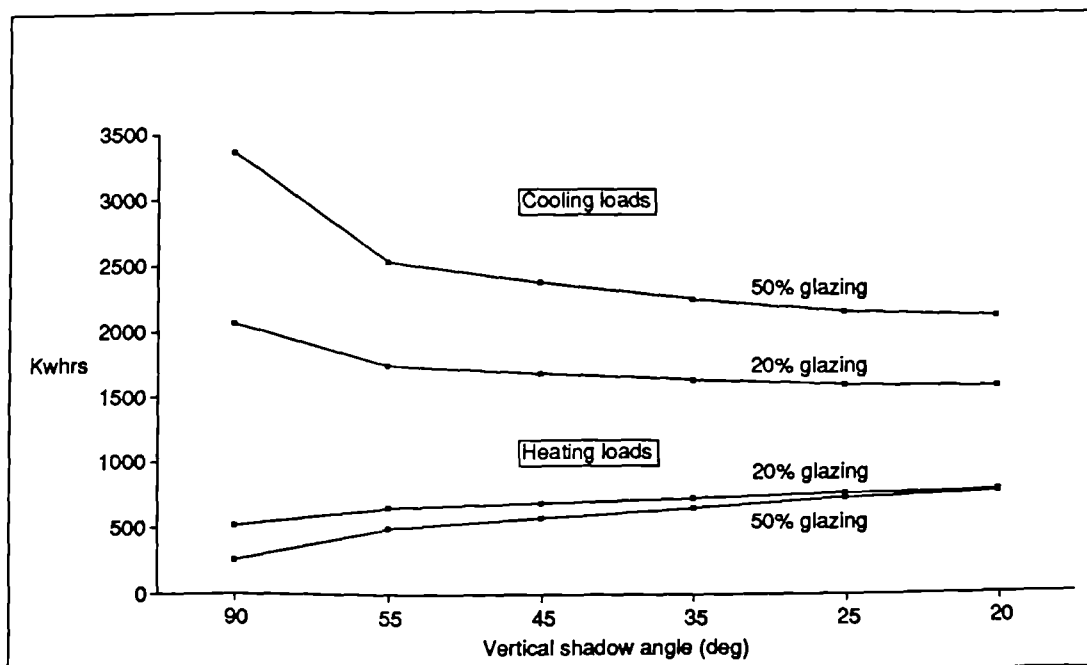

Figure 7.23 The effect of the size of the shading device on the annual cooling and heating requirements of the east facing room

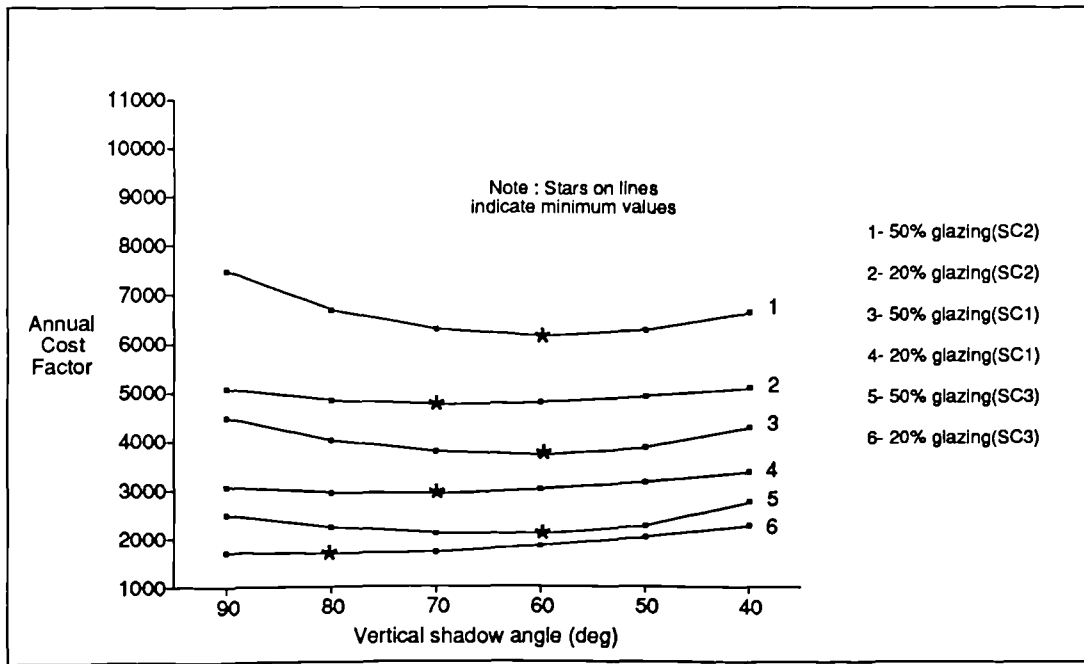

Figure 7.24 Fenestration cost analysis for south facing room

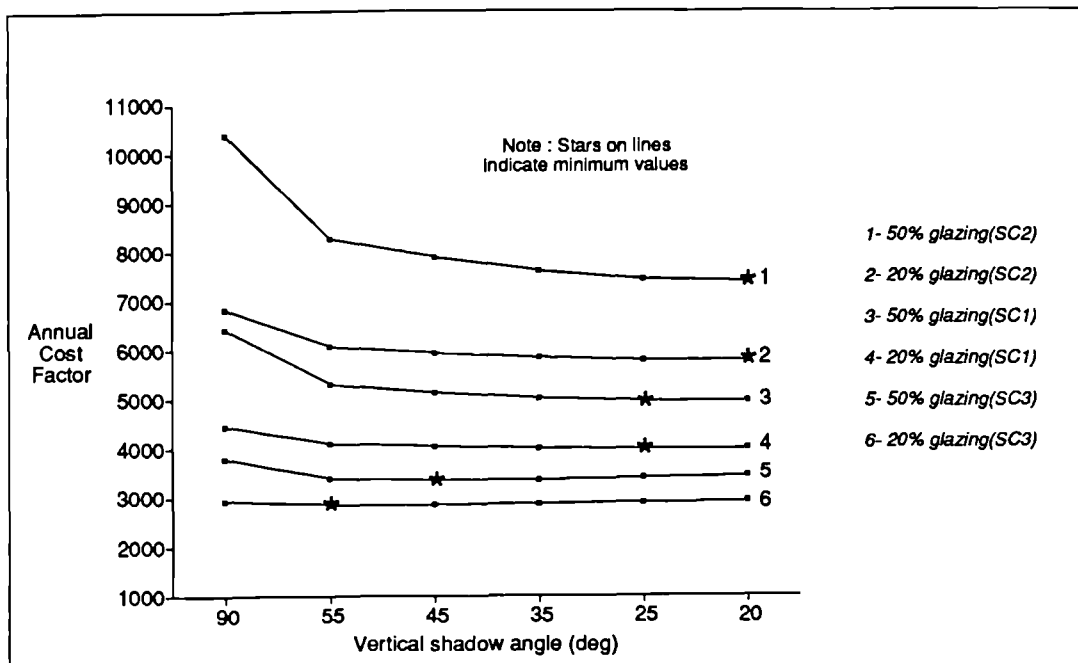

Figure 7.25 Fenestration cost analysis for east facing room

Taking scenario 1 for example, the graph shows that a device having a vertical shadow angle of 60 degrees is the most suitable for large windows while a smaller overhang of an angle of 70 degrees should be sufficient for smaller windows.

The size of shading devices for east facing windows, having a vertical shadow angle of 35 degrees, estimated by the Olgyay Method, seems to be more reasonable (Figure 7.25).

The fact that the estimated size of shading devices designed by using the graphical methods may be larger than required is reported by other researchers [18].

From results obtained, the fenestration design of the reference house (Figure 1.5, Chapter 1) was changed as shown in figure 7.26. The size of the windows of the reference house, each comprising 20% of its wall area, was not changed as it is appropriate to satisfy view out while being reasonably efficient in energy terms. Windows facing east and west in four corner rooms, i.e. zones 1, 3, 7, and 9, were eliminated due to their poor thermal performance.

Since shading on windows facing north does not reveal significant savings, no devices were considered for these windows. Shading devices having a vertical shadow angle of 70 degrees were placed over south facing windows, and those with an angle of 35 degrees on east and west facing windows.

Figure 7.26 Reference house with new window arrangements

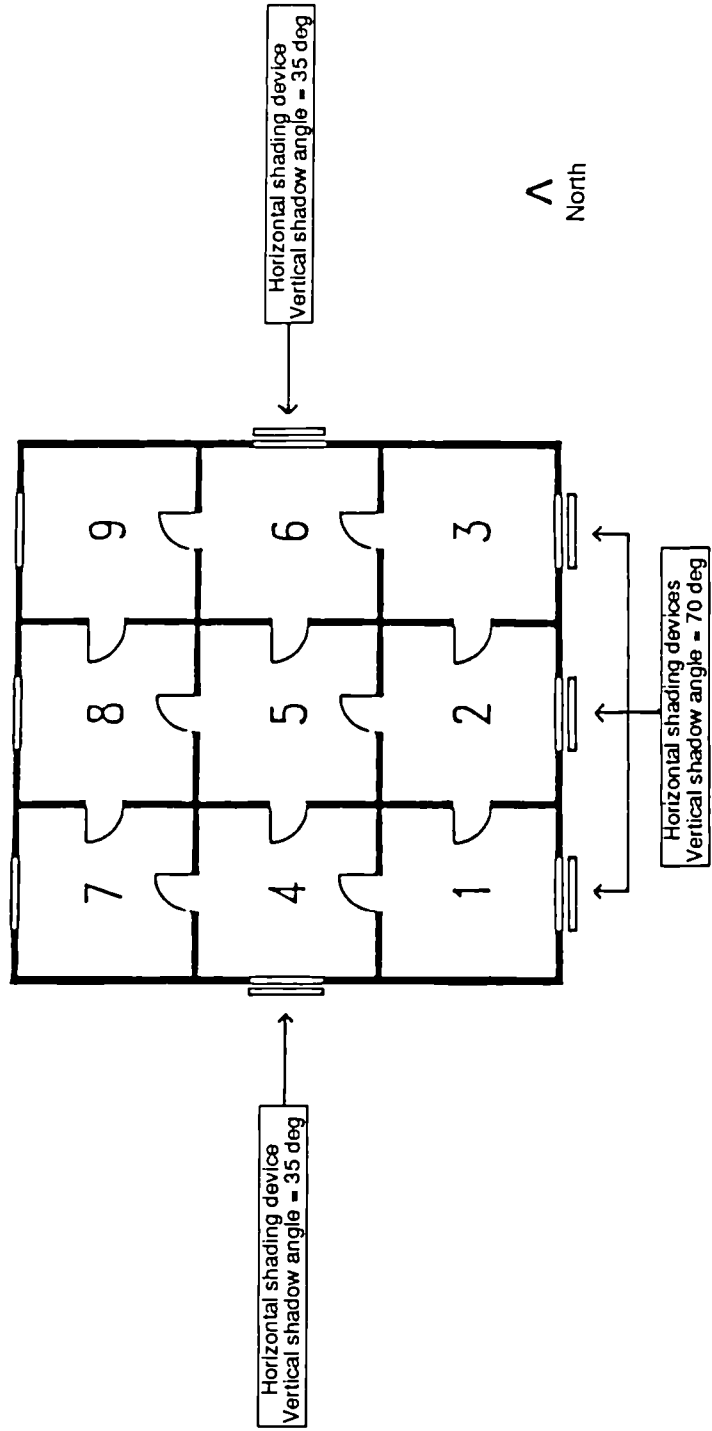

In figure 7.27 are shown the annual heating and cooling loads and the associated Annual Cost Factors (assuming Scenario 1 applies) of both the original reference house (Figure 1.5) and the house with the new window arrangements (Figure 7.26). A substantial saving in the annual running cost as much as 34% has been achieved under the new design strategy.

Reference 19 gives a summary of some of the results obtained in this chapter (see Appendix C).

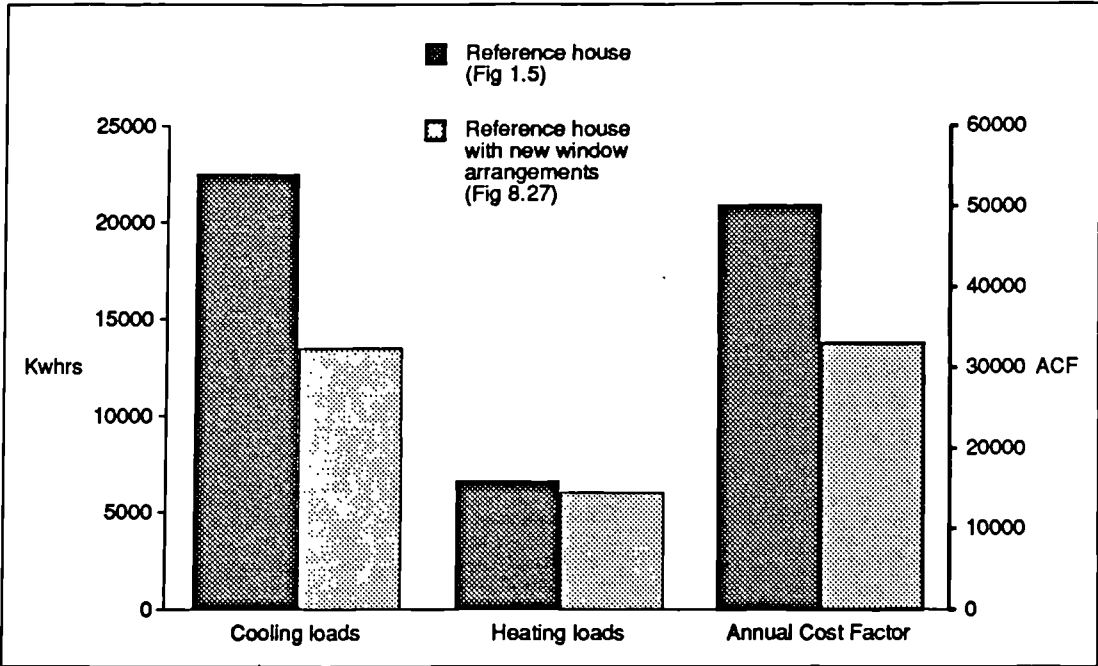

Figure 7.27 The effect of fenestration design on energy requirements and energy cost

7.7 REFERENCES

- [1] McKennan, G.T. *The low energy window. Its impact on the interior visual environment.* Proceedings of windows in building design and maintenance. Goteborg, Sweden. 13-15 June 1984.
- [2] Robinson, P. and Littler, J. *Methodology of window thermal performance assessment techniques in the US and the UK.* Department of Energy, UK, 1989.
- [3] Richards, S.J. *Solar charts for the design of sunlight and shade for buildings in South Africa.* South African Architectural Record, Vol. 36, No 11, 1978.
- [4] Koenigsberger, O.H. *at al Manual of tropical housing and building, climatic design.* Longman, 1973.
- [5] Givoni, B. *Man, climate and architecture.* Elsevier Publishing Company, 1969.
- [6] van Straaten, J.F. *Roof insulation.* South African Architectural Record, February 1964.
- [7] Shaviv, E. *Climate and building design - tradition, research and design tools.* Energy and Buildings, Vol.7 1984.
- [8] Olgyay, A. and Olgyay, V. *Solar control and shading devices.* Princeton University Press, 1957.
- [9] Hopkinson, R.G., Petherbridge, P. and Longmore, J. *Daylighting.* Heinmann, 1966.
- [10] Ne'eman, E. and Shrifteilig, D. *Daylighting of buildings in a hot climate.* Energy and Buildings, Vol.4, 1982.
- [11] Markus, T.A. *The function of windows: A reappraisal.* Building Science Vol.2 1967.
- [12] Tavassoli, M. *Windows in building design and maintenance in the hot dry climate.* Proceedings of ; Windows in building design and maintenance. Goteborg, Sweden, 13-15 June 1984.
- [13] Hopkinson, R.G. *Glare from daylighting in buildings.* Applied Ergonomics, Vol. 34 1972.
- [14] Ne'eman, E. and Hopkinson, R.G. *Critical minimum acceptable window size: a study of window design and provision of a view.* Lighting Research and Technology. Vol.2 1970.
- [15] Keighley, E.C. *Visual requirements and reduced fenestration in office buildings - a study of window shape.* Building Science, Vol.8 1973.

[16] Baxter, A.J. *Windows and energy*. Proceedings of the second international CIB symposium on energy conservation in the built environment. Copenhagen 1979.

[17] Keighley, E.C. *Visual requirements and reduced fenestration in office buildings, a study of multiple apertures and window area*. Building Science, Vol.8 1973.

[18] Etzion Y. *Design of shading devices using a one point method. A technical communication*. Energy and Buildings, 8, 1985.

[19] Sodagar, B. and Warren, B. W. *Window design in hot dry climates*. Proceedings of CIB International Symposium on Energy, Moisture and Climate in Buildings, Rotterdam, September 1990.

Chapter 8

CONCLUSIONS

- 8.1 Summary of findings and recommendations
 - 8.1.1 Introduction
 - 8.1.2 Thermal properties of building structures
 - 8.1.3 Thermal response of buildings
 - 8.1.4 Roof design
 - 8.1.5 Window design
- 8.2 Limitation and future research areas

8.1 SUMMARY OF FINDINGS AND RECOMMENDATIONS

8.1.1 INTRODUCTION

The energy consumed for controlling the thermal environment of buildings forms a major part of the total energy requirements of every nation. The energy crisis of 1973 emphasised the need for conservation of energy in general and in the building industry in particular.

In order to improve energy saving measures in building design, extensive research is being undertaken in developed countries. In contrast, in developing countries and particularly in oil producing countries where the cost of purchasing energy until now has been relatively cheap, not enough attention has been paid to the thermal performance of buildings. The lack of credible information about the thermal interactions between the building and its environment, poor building techniques, materials and workmanship are among the factors contributed to the design of buildings not thermally appropriate to their environments.

The fast means of communication and transportation have encouraged the building techniques and forms developed in the west to be directly implemented in developing countries. Unlike in temperate climates where the main thrust of energy saving measures in buildings is directed towards the heating energy consumed during the winter months because of the prevailing climatic conditions, in hot dry climates for example, conditions are often such that the cooling

requirements are predominant. This necessitates more attention to be paid to those design features capable of reducing heat flows into buildings. As an example, large windows adopted in the design of buildings in hot dry climates not only are inappropriate from the thermal point of view as they may introduce severe energy penalties and/or overheating problems but may also cause psychological disadvantages, e.g. the problems associated with the lack of high level of privacy desirable.

This research is mainly aimed at "explaining" the trends in the energy flows within buildings under the climatic conditions of arid zones. The results should help in the formulation of design guidelines for use in the process of building design by builders, architects and engineers.

The qualitative and quantitative procedures employed in the preceding chapters provided a range of design guidelines. The main results of this study are gathered below and general conclusions are drawn. The areas in which further work is required are also outlined.

8.1.2 THERMAL PROPERTIES OF BUILDING STRUCTURES

The analysis showed that the structural characteristics of the building envelop have an influential effect on the energy flows through the fabric.

The definite effect of thermal mass on heat flows by displacing periods of high energy gains was highlighted by simulations performed in Chapter 4. For example, the analysis of a 220mm brick wall showed that for a 6 hours time lag the heat wave suffers a considerable attenuation in amplitude as it traverses through the wall (Figure 4.4). An insulation panel having the same thermal resistance, while attenuating the outside surface temperature oscillation, provided no distinguishable time lag (Figure 4.3).

Figure 8.1 has been constructed by using some of the heat flow data obtained in Chapter 4 (the signs of inward and outward heat flows have been reversed for better comparison purposes) showing the thermal behaviour of different wall systems in the month of July.

The heat flow peaks at 13.00 hours in the case of the 10mm insulation panel (Figure 8.1(A)). In figure 8.1(B), the energy flow is shown through the 220mm brick wall. The thermal heat storage capacity of the brick wall results in an energy flow which peaks about 6 hours after the corresponding time of the case A. Case C (Figure 8.1(C)), is identical to case A except that heat flow through the wall is reduced because of the increased thermal resistance of the wall. Note that the maximum energy flows occur on the same hours as for case A. Figure 8.1(D) shows the combined effect of mass and insulation on heat flow. Smaller quantities of heat flow more uniformly through the wall.

As the main concern for the site in question is the cooling season, analyses in Chapter 4 were mainly concerned with the energy flow

(A) HIGH U-VALUE, LOW MASS

10mm insulation panel
Heat capacity = 0.120 Kj/m²K
U-value = 2.26 W/m²K

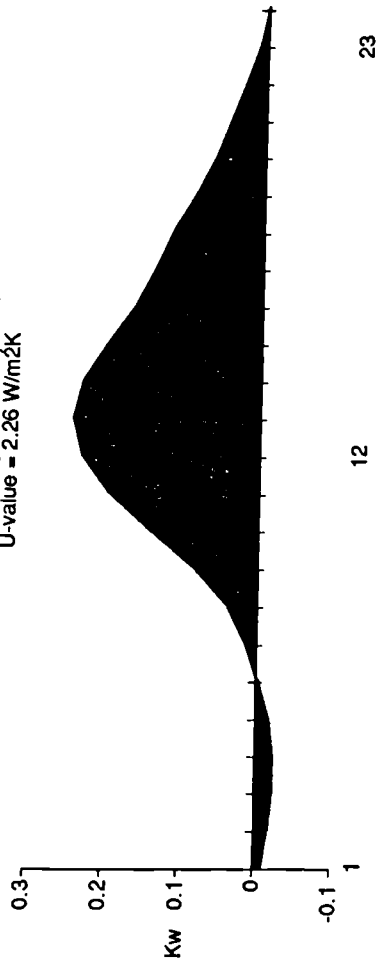

(C) LOW U-VALUE, LOW MASS

27mm insulation panel
Heat capacity = 0.324 Kj/m²K
U-value = 1.13 W/m²K

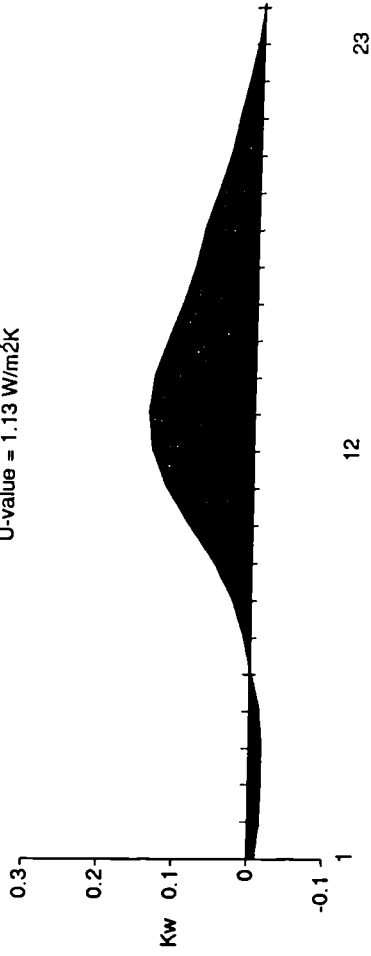

(B) HIGH U-VALUE, HIGH MASS

220mm brick wall
Heat capacity = 299.2 Kj/m²K
U-value = 2.26 W/m²K

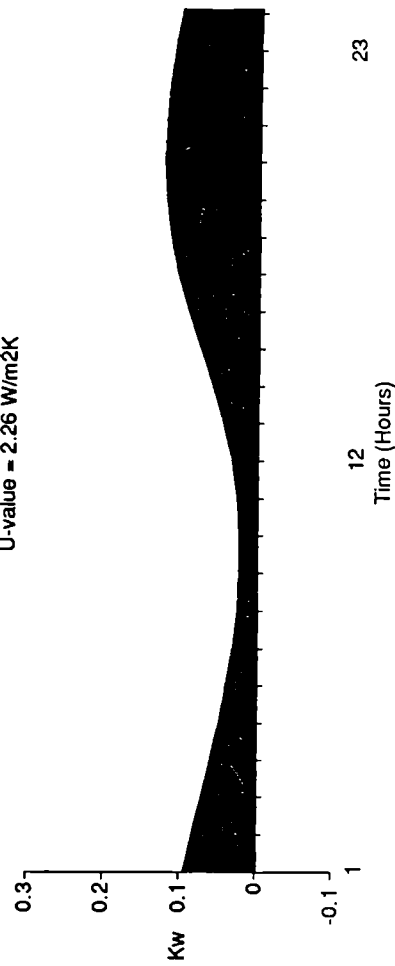

(D) LOW U-VALUE, HIGH MASS

Externally insulated 220mm brick wall
Heat capacity = 299.4 Kj/m²K
U-value = 1.13 W/m²K

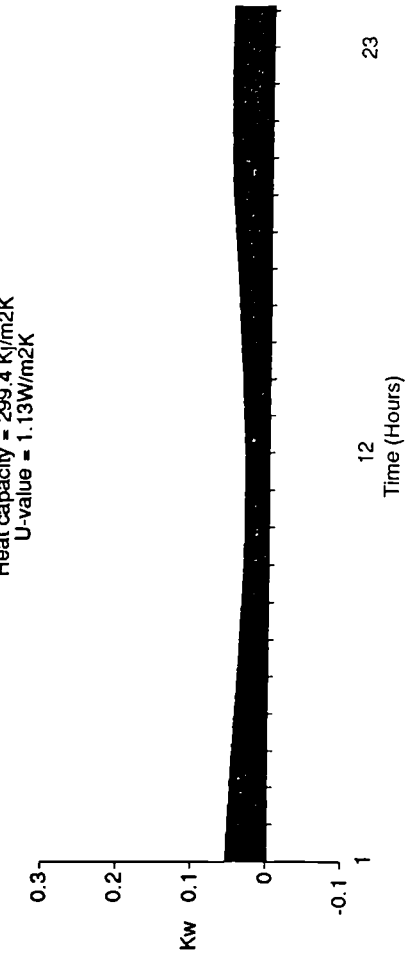

Figure 8.1 The effect of the thermal heat storage capacity and thermal transmittance on the energy flow through walls

(positive signs indicate inward flows of energy and negative signs outwards flows of energy)

through the fabric in the hot period of the year. In this respect, from the results obtained, the main conclusions can be summarised as follows:

- 1- the building envelope should provide an appropriate time lag in order to delay much of the heat gain until it can be removed cheaply, e.g. until the evening hours when the ambient temperature is low and cooling efficiency is higher. A time lag of the order of 6 hours which may be achieved by conventional structures, e.g. 220mm brick walls, seems to be appropriate.
- 2- the "fly wheel" effect of mass on levelling out the heat flow through the envelope and reducing peak loads should be used to advantage to enable conventional environmental control equipment of smaller capacity to be used.
- 3- the inner parts and the internal surfaces of structures of high thermal heat storage capacities undergo smaller variations in temperature compared with thermally light structures (Figures 5.10 & 5.11) resulting in more stabilised internal environments.
- 4- the spatial disposition of the layers in a multi-layer construction may have a profound effect on its thermal behaviour. Thermal mass should not be isolated from the interior of buildings, it should be positioned inside, as opposed to outside. The wall with thermal mass inside maintains a more stabilised internal surface temperature than the wall with insulation inside (Figure 5.12).
- 5- as lining masonry walls with light weight materials would isolate the thermal heat storage capacity of the wall from the interior, care must be exercised in selection of plasters for masonry walls. Plasters while they should be of high thermal conductance, should also be in good thermal contact with the wall.
- 6- thermal heat storage functions more effectively when the diurnal temperature swings to either side of the thermostat set points. For example, in the month of May when outdoor temperatures at night are low, significant thermal mass effect may be observed (Figure 5.13). In contrast during the hot spell of the cooling season, e.g. July, when diurnal temperatures are above the set point, thermal mass has a relatively small effect as the heat flow through the fabric approaches steady state conditions.

- 7- the inclination of a surface with respect to solar altitude determines the amount of solar radiation the surface receives. The roof receives the highest amount of radiation in summer and consequently experiences the highest surface temperatures (Figure 5.14). This requires attention be paid to reducing the effect of radiation, for example by lowering the roof solar absorptivity, i.e. using light colour materials or paints or shading the roof.
- 8- due to the effective radiation heat loss from the roof to clear night skies in hot dry climate, the surface temperature of the roof can fall below the ambient temperature (Figure 5.15). This accelerates the heat loss through the roof which makes the roof a main route for energy loss through the cold period of the year.
- 9- buildings should be externally finished in light colours to reduce the heat gains through the fabric. Internal surface temperatures of sunlit surfaces can be reduced appreciably by applying light colours to their external surfaces (Figures 5.16 and 5.18).
- 10- comparing the cost of applying insulation and re-painting the walls with light colours, the latter is more attractive. The most attractive option is however, the selection of light colour materials which do not need painting, e.g. light colour bricks, stones, etc.

8.1.3 THERMAL RESPONSE OF BUILDINGS

Simulations in Chapter 5 indicated that thermal mass can be useful in houses for two reasons:

- 1- to store surplus energy from "nonsynchronous" sources (for example solar radiation, metabolic heat of the occupants, daily swings in outdoor temperature) for periods when it can be used to reduce auxiliary energy demand (heating and/or cooling output from the equipment).
- 2- to moderate temperature swings resulted from fluctuations in energy input from "nonsynchronous" energy sources.

The results indicated that under the boundary conditions in the site under investigation, thermal mass can take advantage of "nonsynchronous" energy sources to reduce the auxiliary energy demand (fuel based energies) of buildings and to produce more uniform internal environments by moderating temperature swings.

The computer simulation results also confirmed that the optimal orientation for space heating in the northern hemisphere is toward south. Thermally heavy buildings (masonry with external insulation) can take greater advantage of significant solar gains in spaces facing south to reduce auxiliary heating requirements. As thermally lightweight structures (masonry with internal insulation) offer fast response to energy input (as they do not store energy very well), they are prone to produce wide fluctuations in air temperature which may lead to extremely uncomfortable environmental conditions and serious complaints.

As the inclusion of thermal mass led to increased heating requirements of north facing rooms, the question arises where and when to include more thermal mass. The results of thermal analysis suggests that thermally light structures can be used for a fast thermal response in areas (or under conditions) which receive no solar energy or in rooms which are only intermittently used.

The results of thermal comfort analysis highlighted the common problem of thermally light buildings; excessively high temperatures as the result of their quick response to energy gains from "nonsynchronous" energy sources.

In summary, thermally heavy buildings should:

- 1- *improve the energy efficiency of buildings for both heating and cooling (Figure 5.12).*
- 2- *make beneficial use of solar gains in reducing heating demands (Figures 5.2 and 5.3) which would otherwise overheat building interiors (Figures 5.13 to 5.15).*
- 3- *allow strategic use of diurnal temperature variations especially when the diurnal temperature swings to either side of thermostat set points (Figures 5.2 and 5.3).*
- 4- *provide thermally more comfortable environments (Figures 5.16 to 5.19).*
- 5- *Thermal mass may cause energy penalties, e.g. in the north facing spaces (Figures 5.4 and 5.5) where it can not take advantage of available energy from nonsynchronous energy sources for example, fluctuations in incoming solar radiation. One solution to this problem may be the massing of buildings, i.e. having lightweight walls in the north facing spaces and heavyweight walls facing other orientations. However, there might be serious structural drawbacks associated with this method as it causes inconsistency in the construction requiring more complicated structural details with a possible rise in the cost.*

Due to special zoning strategy of the reference house, on the base of the results revealed through simulation runs, some design guidelines of most general interest, for example, the space allocation with regard to orientation, may be suggested.

Non-habitable zones, e.g. services, garages, etc. should be arranged in such a way as to protect habitable zones from severe external conditions. East and west orientation should be avoided if possible, e.g. by appropriate layout planning such as arranging houses in rows facing south-north.

8.1.4 ROOF DESIGN

The design of roofs is crucial in hot dry climates. The thermal design of roofs is very often given inadequate attention in the tropics. In spite of the fact that in the tropics the roof may receive the greatest proportion of the sun's radiation because of its inclination with respect to solar altitude, it is not uncommon to find that walls and windows are carefully planned in relation to the sun but that little is done to minimise the effect of the sun on the roof. One reason for this negligence is that the roof is the building component least exposed to visual contact.

There are several ways of reducing solar heat gains through roofs. These include the use of insulation, reducing the solar absorptivity of the exposed surface of the roof and shading.

The purpose of insulating roofs is twofold; firstly to reduce heat gains and losses through the roof and thus ensure better indoor thermal conditions and lower energy consumption and, secondly, to reduce the thermal movements of the structural deck which otherwise may be subject to high temperature variations. To achieve these, insulation should be applied on top of the deck as opposed to beneath, e.g. as in the "warm roof" or the "protected membrane roof".

Simulation runs were performed for both dark and light coloured roofs. The results confirmed that where the extreme surface temperature is a consideration, the light coloured roof shows a

considerable advantage (Figure 6.5). Table 8.1 has been arranged to give a comparison of maximum temperatures taken from figure 6.5.

Table 8.1 Maximum surface temperatures (C) of asphalt

Level of insulation	Colour: Dark	Light
None	57	46
25 mm	61	48
50 mm	62	48.5
100 mm	62.5	48.7

Table 8.2 has been recast taking data from figure 6.6 to show changes in annual loads due to increasing the insulation thickness for dark and light coloured roofs.

Table 8.2 The effect of insulation thickness and colour of the roof on annual loads (Kwhrs)

Insulation thickness (mm)	Light colour		Dark colour	
	Cooling	Heating	Cooling	Heating
0	24508	11759	27728	9075
25	23119	7922	24726	6773
50	22641	6740	23714	6042
100	22251	5868	22897	5482

Table 8.3 gives reductions in loads (Kwhrs/m² of roof area) due to insulation thickness. And finally table 8.4 gives correction factors to be applied when changing the colour of the roof from dark to light or vice versa.

Table 8.3 Reductions in annual loads as a function of insulation thickness (Kwhrs/m²)

Insulation thickness (mm)	Light colour		Dark colour	
	Cooling	Heating	Cooling	Heating
0	0	0	0	0
25	6.17	17.05	13.34	10.24
50	8.30	22.31	17.84	13.49
100	10.03	26.18	21.47	15.98

Table 8.4 Correction factors (Kwhrs/m²) for roof surface modifications

Insulation thickness	0	25	50	100
Cooling	14.31	7.14	4.77	2.87
Heating	11.92	5.11	3.10	1.72

By using table 8.4, in the cooling season the correction is added to the saving if the roof colour is changed from dark to light and subtracted if changing from light to dark. In the heating case the converse applies since changing from dark to light increases heating loads. For example, changing the colour of an uninsulated roof from dark to light will result in a reduction in the cooling load of the order of 14.31 Kwhrs per square metre of the roof area. In contrast, the heating load would be increased by 11.92 Kwhrs/m² of roof area as the result of the surface modification. Tables 8.3 and 8.4 could be used by designers to assess energy savings associated with the design of the roof.

For single storey houses, simulation results also showed that insulating the roof is more effective in reducing loads than insulating the external walls (see Table 6.2, Chapter 6). The cost effectiveness of roof insulation becomes even more attractive as the cost of insulating the roof is in general less than that for the walls.

In hot dry climates where precipitation is sparse there is no serious problem regarding rain penetration through the external walls. This allows the external walls to be built in the form of a single leaf of masonry materials plastered internally. The external surface of the leaf, e.g. the brick wall, serves as the external finish requiring the minimum maintenance cost.

Incorporation of the insulation in the design of the external walls, which should be applied externally to be effective, would reduce the

construction simplicity of the external walls and lead to increased construction costs. The design of roofs, however, is more elaborate. As explained in Chapter 6, the roof is a component composed of different elements each of which is usually required to perform a well defined function. Applying one layer of insulation which can simply be laid on for example "screed to fall" (as in the "warm roof" type) is more justifiable.

Sunlit roofs experience dramatically higher temperatures during hours of solar exposure than those experienced by unexposed roofs. Shading the roof is an effective measure in reducing the roof surface temperatures and consequently heat flow through it. However, roof shading may have several disadvantages. These include the initial cost, cost of maintenance and problems of aesthetic considerations. In places where the use of the roof terrace is socially acceptable, the shading device may deprive the house of this desirable space. It should also be recognised that in the case of fixed shading devices, reduction in cooling loads may be offset by an increase in the heating loads since part of the welcome radiation in winter would be obstructed.

In summary the results suggest that;

- 1- *in all cases considering the feasibility of different approaches to reduce the heat gains through the roof, one should give serious consideration to lowering the roof solar absorptance.*
- 2- *as the cost effectiveness of roof insulation is attractive, one design strategy for total cost savings would be uninsulated massive walls and well insulated roofs of lighter weight. The external walls act as the thermal heat storage capacity and would bear the load of the roof eliminating the need for columns, etc.*

- 3- *of all the materials employed for waterproofing of flat roofs, by far the most widely used is bitumen, mainly in the form of mastic asphalt. As high temperatures could severely shorten the service life of the asphalt, the use of "Protected membrane roofs" should be encouraged to protect the asphalt from extensive temperature variations (Figure 6.4).*

- 4- *shading the roof can be an effective means of reducing ceiling temperatures (Figure 6.9). This not only will reduce the cooling requirements of buildings, but will provide more comfortable environments.*

8.1.5 WINDOW DESIGN

The design of windows plays an important role in overall performance of buildings. Windows should not only be thermally efficient, they should satisfy psychological reactions associated with windows. This means that in thermal performance assessments regarding fenestration design factors such as view, privacy, daylight, etc. should be taken into account.

The simulation results indicated that windows have a major role in creating a balanced indoor environment in hot dry climates. Though the sun is welcome in winter as it gives rise to a pleasant reaction in cold days and reduces heating loads, solar heat gain through windows during summer days can be a considerable nuisance and a major factor in increasing cooling loads. In addition, the fact that windows usually provide easier paths to conductive heat flows due to the lower thermal resistance of glass compared with the opaque portion of the building fabric, makes the design of openings more crucial.

Since east and west facing spaces are poor from an energy management point of view, they should be allocated if possible to non-living spaces, e.g. bathrooms, garages, etc. where smaller openings are justifiable. Otherwise, they should be adequately protected against solar radiation. One design strategy is to avoid if possible east and west orientations, e.g. by appropriate layout planning such as arranging houses in rows facing south-north. Habitable rooms should face south overlooking the private garden where larger windows are justifiable without disturbing the privacy. Landscape design should be used to advantage to control the luminance of the yard to reduce undesirable factors such as glare. Vegetated yards not only screen the reflected light from the ground and surrounding surfaces but would improve the microclimate (Examples of this were given in Chapter 2).

The importance of shading a building's windows to reduce the penetration of the direct solar beams to the interior of the buildings and consequently to reduce cooling loads was emphasised by computer simulations. Shading devices should be sized to exclude direct summer sun rays while allowing them in winter for space heating.

On the base of the sensitive computer simulation results window shading devices of the following sizes, expressed in vertical shadow angles (horizontal devices), are recommended:

North: *Do not need devices*
South: *70 degrees*
East and West: *35 degrees*

The distribution of glazing in the facades of the house can have a considerable effect on its energy consumption. For the prototype house modelled savings of 34% in the annual running cost of the house were obtained when its glazing was redistributed (Figure 7.26).

8.2 LIMITATIONS AND FUTURE RESEARCH AREAS

This study examined the relationship between various building parameters/strategies and the attainment of energy savings and thermal comfort. There are, however, a number of inherent limitations which require cautious judgement in the direct application of the findings of this research. Some limitations are associated with the research methodology, others are presented by the amount and type of available data required by computer simulation program, e.g. climatic data, while some are due to the computer program.

While care was taken to ensure that the prototype house selected is representative, it is important to recognise that the prototype should be considered as a case study aiming at revealing useful information regarding the trends and qualitative effects of architectural design solutions on the thermal performance of houses. Although design guidelines of a general nature can be formulated on the basis of the findings of this research, caution must be exercised in projecting the results onto other building forms deviating significantly from the general description of the prototype.

In pursuing this research, as imposed by the methodology of the study, only a limited number of parameters were dealt with as the possible combinations of all parameters are infinitely large. For the same reason only one representative building prototype was modelled.

The study was limited to analysing the effect of the currently feasible design solutions. The cost effectiveness of some energy conservation measures, e.g. use of special window systems, may become attractive enough in the near future, as the result of the reduction in their initial cost and/or increase in the cost of purchasing energy, to justify their use. This necessitates further research to be undertaken into the effect of those parameters which have not been studied in this work.

In the absence of hourly measured climatic variables for Iran, prediction routines were employed to obtain hourly values. Approaches of this type, e.g. assuming sinusoidal temperature distributions for the ambient air, are usually sufficient for studies of the type of the present work which seek to "explain" the energy flows in the building and are mainly concerned about the trends and qualitative effects of design solutions. However, as the use of building energy simulation programs is becoming more common in developing countries, this suggests the existence of avenues for further work in order to collect the main climatic variables in formats required for energy simulation modelling, e.g. at frequencies of one hour.

Computer simulation programs are design tools developed to assist the engineer or designer in creating thermally more efficient buildings. They are extremely valuable research tools in predicting the thermal performance of buildings as it is often impractical (due to affordable cost and time) to build test buildings in order to analyse the effect of different design solutions on the thermal performance of buildings.

The limitations due to the computer program are technical in nature. In ESP, like any other program, a number of simplifying assumptions have to be applied to the underlying thermal network and/or solution schemes, e.g., by neglecting some flowpaths, assigning fixed values or simplifying boundary conditions in order to lessen the computational overhead and the input demands on the user. Due to the limitations associated with computer programs, the results from simulation programs therefore should be considered as only "the best estimate at the time".

This research effort was aimed at providing design guidelines only for one major climatic region of Iran; her hot arid zone. Further research should be undertaken to document the appropriate design guidelines for use in the process of building design in other climatic regions of the country.

Finally, there is a lack of credible information for consistent performance assessments. Recently it has been realised that there is a growing need for standardisation of thermal performance assessment methods as their world wide use spreads. Future research in this

area not only ensures that generation of data, selection of parameters, assumptions made, etc., would be standardised, but makes the comparisons of results obtained by different researchers more comparable.

Appendix A

Choice of the appropriate computer program

A.1 CHOICE OF THE APPROPRIATE COMPUTER PROGRAM

The appropriate choice of a method to assess the thermal performance of a building depends on factors such as the nature of the problems involved, the nature of the physical phenomena involved, the extent of results required etc. The choice of a method is also affected by constraints such as cost, facilities and manpower available. These constraints may be more deciding factors in real design projects carried out in professional offices. By contrast in a research study, where broader objectives may be set, the scope can be widened in order to derive more general lessons and messages.

The choice of a method is also dependent upon the application concerned. For example, at an early design stage broad estimates on a "rule of thumb" basis may be acceptable to guide the design while, at the later stages, use of advanced methods may be justified for refining the solution.

For reason of simplicity, early works made the assumption that there are steady state conditions within and at the boundaries of the fabric for solving the problem of heat flow in buildings. The steady state method uses the concept of U - value as the only thermal performance factor.

Assumptions made to simplify heat flows under steady state conditions, are not generally accurate. Transient conditions occur both outside and inside which affect the heat flow through the building elements instantaneously and temporally. Therefore, in

order to analyse the complex interactions of factors affecting the thermal behaviour of buildings, it may be necessary to use more complex methods.

Having explained the climatic conditions of the site under investigation in chapter 2, the steady state method cannot address the prevailing boundary conditions. In hot dry regions, having large diurnal variations in climate, the thermal storage capacity of the fabric plays an important role in governing the thermal performance of enclosures. The steady state calculations cannot take into account this property of materials. Furthermore, they do not preserve the spatial integrity of multi-layer construction. As was shown in Chapter 4, elements having the same U-value behave differently depending on the relative position of their layers. In addition, steady state calculations have no mechanism for the accurate inclusion of the effect of solar gains, casual gains, longwave radiation exchanges, plant operational strategies, etc.

To satisfy the objectives of this research, it was necessary to select a computer simulation program utilising transient techniques capable of handling transient multimode heat transfer problems. The program should be capable of handling problems such as;

- *The transient conduction of heat through the enclosure envelope and therefore the associated lag and thermal storage effects.*
- *The time-dependent sensible and latent gains from occupants, lights, equipments etc. and the relative split of these gains into radiant and convective portions which will dictate how they are delayed in time by the system.*

- *Infiltration, natural and controlled ventilation, and inter-zone air movement.*
- *The effects of shortwave solar radiation impinging on exposed external and internal surfaces.*
- *The longwave radiation exchange between exposed external surfaces and the sky vault and the surroundings.*
- *The corresponding longwave radiation exchange between internal surfaces.*
- *The shading of external opaque and transparent surfaces as caused by surrounding buildings as well as a variety of facade obstructions.*

With the growing number of dynamic computer programs available, the criteria for selection the appropriate simulation program(s) therefore becomes of prime importance.

Wiltshire and Wright [1 & 2] suggest four key areas as the criteria for the selection of a program. These are;

- 1 - *Credibility*
- 2 - *Performance Assessment Capability*
- 3 - *Ease of Use*
- 4 - *Resources*

Credibility is taken as a belief that simulation results are not too far removed from reality. It has been considered in terms of;

- *Acceptance by the modelling community.*
- *Extent of participation in validation exercises.*
- *Technical appraisal of the program and algorithms.*

Performance Assessment Capability can be considered in terms of;

- *The aspects on which a design is assessed.*
- *Features which the program was capable of representing.*
- *Application of the program to example design cases.*

Ease of use covers all aspects of using the program, in the areas of:

- *The user interface.*
- *Quality and extent of documentation and user support.*
- *Modification and development of the program.*

Resources are considered in terms of;

- *Manpower required to set up and to run simulations.*
- *Hardware requirements.*
- *Computer run times.*

By applying the above criteria, initially the authors considered 8 possible programs suitable for passive solar design (Table A.1).

Table A.1 Candidate Simulation Programs [2]

Model	Method	Origin	Status
BLAST	Response Factor	USA	Public Domain
DEROB	Finite Difference (implicit)	USA	Public Domain
DOE-2	Response Factor	USA	Public Domain
TAS	Response Factor	UK	Commercial
APACHE	Finite Difference (explicit)	UK	Commercial
SERI-RES	Finite Difference (explicit)	USA/UK	Public Domain
HTB2	Finite Difference (explicit)	UK	Public Domain
ESP	Finite Difference (implicit)	UK	Public Domain

By applying other two criteria in selection of programs listed in table A.1, as;

- *There should be acceptance of the program in the UK with an established user community.*
- *The theoretical basis of the program should be open to inspection and the source code made available.*

Wiltshire and Wright [1 & 2] arrived at a list consisting of only 3 programs; ESP, HTB2 and SERI-RES. The authors then gave each program a factor of goodness considering criteria mentioned before. ESP was favoured for its overall performance.

Bowman and Lomas [3] by applying similar codes in their evaluation of programs have arrived at a list consisting of 5 programs which are listed in table A.2.

Table A.2 Candidate Simulation Programs [3]

Models	Method	Origin	Status
ESP	Finite Difference (Implicit)	UK	Public Domain
SERI-RES	Finite Difference (Explicit)	USA/UK	Public Domain
BLAST	Response Factor	USA	Public Domain
DEROB	Finite Difference (Implicit)	USA	Public Domain
HTB2	Finite Difference (Explicit)	UK	Public Domain

Littler [4 & 5] concluded that ESP, BLAST, DEROB and SUNCODE (which is essentially the same as SERI-RES), were potentially the most suitable candidate simulation programs for passive solar design.

In the search for the most appropriate simulation program to solve the problems at hand, on the base of the work carried out by Wiltshire and Wright [1 & 2], ESP was chosen as the design aid for this study.

The foundation of ESP was laid between 1974-77 when ABACUS group at the University of Strathclyde, Glasgow, investigated the various theoretical techniques for modelling energy flow; simple dynamic, response factor and finite difference. The latter technique was favoured. By 1977 a working prototype of ESP existed based on implicit finite difference energy balance formulations.

Validation exercises are usually carried out to test the validity of a program's theoretical basis and its ability to reproduce observed performance. General good agreements have been obtained between the measured and predicted data using ESP [6,7] under the climatic conditions of temperate climates. There are sufficient evidences that the program is also appropriate for simulations carried out for warmer climates. For example, Kolokotroni and Young [8] report good agreements between the predicted results from ESP and measured data from different houses ranging from vernacular (thermally heavy weight) to contemporary (thermally lighter) in the hot climate of Greece. Figure A.1, as an example, shows the good agreements

between the predicted and measured air temperature and relative humidity in the hot period of the year in Tripolis, Greece.

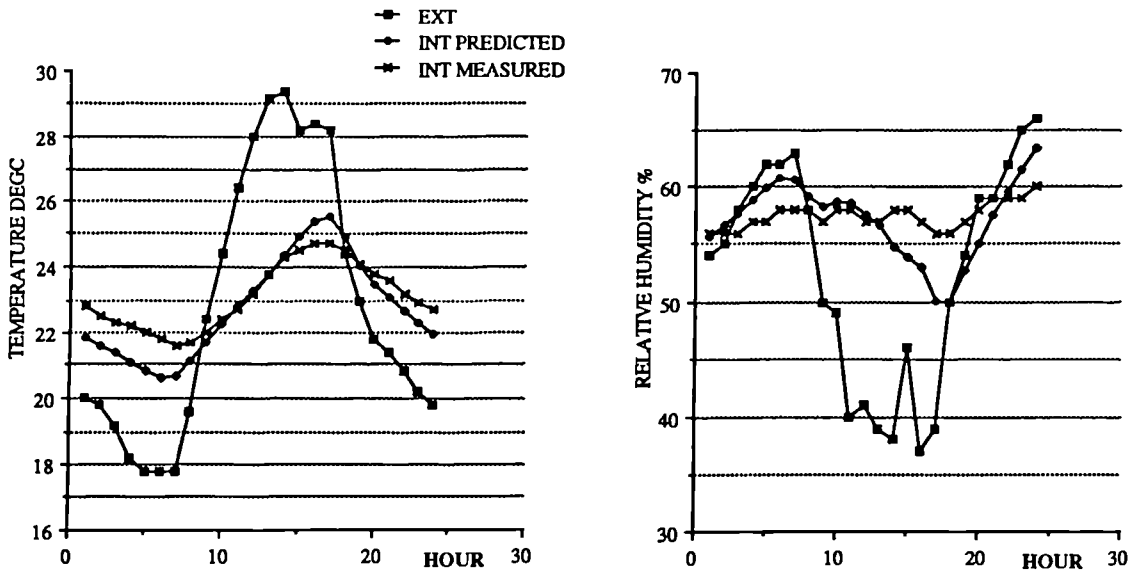

Figure A.1 Comparison between the predicted and measured air temperature and relative humidity for a house in Greece in summer [8].

A.2 REFERENCES

- [1] Wiltshire, T.J. and Wright, A.J. *The documentation and evaluation of building simulation models*. Building Environmental Performance Analysis Club (BEPAC), Technical note 89/2, November 1989.
- [2] Wiltshire, T.J. and Wright, A.J. *The evaluation of the simulation models ESP, HTB2 and SERI-RES for the UK Passive Solar Programme*. A report prepared for the Energy Technology Support Unit of the Department of Energy. Building Science Section, School of Architecture, University of Newcastle upon Tyne, August 1987.

[3] Bowman, N.T. and Lomas, K.J. *Empirical validation of dynamic thermal computer models of buildings*. Building Services Engineering Research & Technology, Vol.6, No.4, 1985.

[4] Littler, J.G.F. *Overview of some available models for passive solar design*. Computer Aided Design, Vol. 14, No. 1, 1982.

[5] Littler, J.G.F. *Review of some promising simulation models for passive solar design*. Sun at Work in Britain, Vol. 16, 1983.

[6] Department of Environment, Building Research Establishment, *Glasgow commercial building monitoring project, Final Report for Annex IV on Energy Conservation in Buildings and Community Systems*. UK, 1980.

[7] Gough, M. *ESP simulation of Canadian direct gain test cell, Report for the International Energy Agency Task VIII, Sub-task B, Validation Exercise*. 1984.

[8] Kolokotroni, M. and Young, A.N. *Guidelines for bioclimatic housing design in Greece*. Building and Environment, Vol.25, No.4, 1990.

Appendix B

Weather data generation

B.1 WEATHER DATA GENERATION

B.1.1 INTRODUCTION

The use of climatic data in building design is associated with two principal goals;

- (1) *Thermal comfort for building occupants*
- (2) *Energy management of the building*

To achieve these goals physical data such as; dry-bulb temperature, solar radiation (direct and diffuse), wind patterns, atmospheric pressure, etc. are required.

Although significant attempts have been made in Europe and North America to collect the main climatic variables in formats required for energy simulation modelling, e.g. at frequencies of one hour, there are still many cities particularly in developing countries for which the detailed data suitable for building design using environmental computer programs are not available.

For localities in Iran, the available climatic data provide monthly mean, maximum and minimum values for air temperature, relative humidity, wind speed and the prevailing wind direction. Data for solar radiation are almost missing.

The monthly mean values for each of the 12 months, and specially as many years' average for the same month, would give a reasonably accurate picture of temperature, humidity and wind conditions, on

which the design work can be based [1]. The followings detail the procedures used to simulate the hourly values of climatic variables required as input in ESP.

B.2 SOLAR RADIATION PREDICTION

In order to predict the amount of solar energy received by a building, the hourly solar values were predicted using mathematical models as there is no measured solar data available for Iran. As the only region where the influence of clouds on solar radiation can be safely ignored is the desert [2], the techniques developed by Rodgers et al [3] for the prediction of direct normal and diffuse horizontal solar radiation under cloudless sky conditions supported by ESP were used to predict hourly solar values.

B.2.1 DIRECT NORMAL INTENSITY

Based on experimental observations it is possible to relate the direct normal irradiance to atmospheric conditions and the prevailing air mass such that;

$$I_{dn} = I'_{sc} \exp\left[\sum_{i=0}^3 \left(\sum_{j=0}^2 b_{ij} W^j\right) m^i\right] \exp(-B m) \quad (\text{B.1})$$

Where;

I'_{sc} is the corrected solar constant (due to variable sun-earth distance), W/m^2

b_{ij} is a constant as given in table B.1

W is the level of atmospheric precipitable water content, mm

m is the air mass level or atmospheric path length,

and B is the atmospheric turbidity coefficient.

Table B.1 Constant b_{ij} for use with equation B.1

j	i	0	1	2	3
0		-0.12964100	-0.06421110	-0.00468830	0.000844097
1		0.00412828	-0.00801046	-0.00220414	-0.000191442
2		-0.01120960	0.01530690	-0.00429818	0.000374176

The corrected solar constant, I'_{sc} , is found from:

$$I'_{sc} = I_{sc} (1 + 0.033 \cos[(360 - Y)/370]) \quad (B.2)$$

Where I_{sc} is the solar constant evaluated at the mean sun-earth distance, and Y is the year day number (January 1 =1, February 1 = 32, etc.). The value assigned to the mean solar constant is 1353 W/m^2 [4].

The precipitable water content(W) which is the water level which would result from the condensation of all water vapour contained in a vertical column extending from the earth's surface of the locality in question to the outer limits of the atmosphere, may be readily computed through a number of standard routine atmospheric observations, such as relative humidity, ambient temperature, dewpoint temperature or vapour pressure. Igbal [5] has summarised some of the most commonly used methods of computing the precipitable water content of the atmosphere. Leckner's formula [6] gives the

amount of the precipitable water content as functions of the ambient temperature and the relative humidity such that:

$$W = 0.493 (RH/T) \exp(26.23 - 5416/T) \quad (B.3)$$

Where T is ambient temperature in degrees Kelvin and RH is relative humidity in fraction of one.

By substituting the monthly mean average values of ambient temperature and relative humidity (Table B.4) in equation B.3, the precipitable water contents for different months of the year for the City of Yazd were calculated and are given in table B.2. The "mean" in table B.2 is simply the mean of the 12 monthly values.

Table B.2 The precipitable water content, mm

Months												
J	F	M	A	M	J	J	A	S	O	N	D	Mean
8.2	8.6	9.4	12.7	12.4	11.1	10.5	10.2	9.3	9.1	9.1	7.9	9.88

The barometric pressure of a site as a function of its altitude may be found from [7]:

$$P_h = P_0 \exp\left[\frac{-p g_n h}{1000 p_0} \right] \quad (B.6)$$

Where:

P_h = barometric pressure at altitude h , KPa
 P_0 = barometric pressure at sea level (= 101.325), KPa
 p = density of air (= 1.20), Kg/m³
 g_n = acceleration due to gravity (= 9.81), m/s²
 h = altitude, m

For the City of Yazd, Substitution of the value of 1230m for h in equation B.6 yields; $p_h = 87.83$ KPa (= 878.3 mb).

For locations at latitude 30°N having an air pressure of 900 mb under dry or cold conditions, which closely represent the geographical and atmospheric conditions of the City of Yazd, Robinson [2] based on the published data suggests limits of 20mm and 4mm for W with a mean value of 10mm.

As demonstrated in figure B.1, the effect of variations in W on the amount of irradiance received at the earth surface is practically negligible. For this study, the suggested mean value of W (10mm) by Robinson [2] for hot dry climates, which agrees well with the mean of values calculated by Leckner's formula (Equation B.3), was used to represent the level of the atmospheric water vapour for the City of Yazd.

Representation of atmospheric turbidity (B) through Angstrom's turbidity coefficient is very common. Angstrom's formulae as quoted in [2] for the geographical distribution of B are:

$$B_0 = 0.040 + 0.085 \cos^2 L \quad (B.4)$$

$$B = B_0 \exp(-0.0005 h) \quad (B.5)$$

Where:

B_0 = turbidity coefficient for latitude L at sea level
 L = the geographical latitude, degrees
 B = turbidity coefficient for latitude L at altitude h
 h = altitude, m

For the City of Yazd, substitution of 32° and 1230m for L and h respectively in the above equations will yield a value of 0.056 for B .

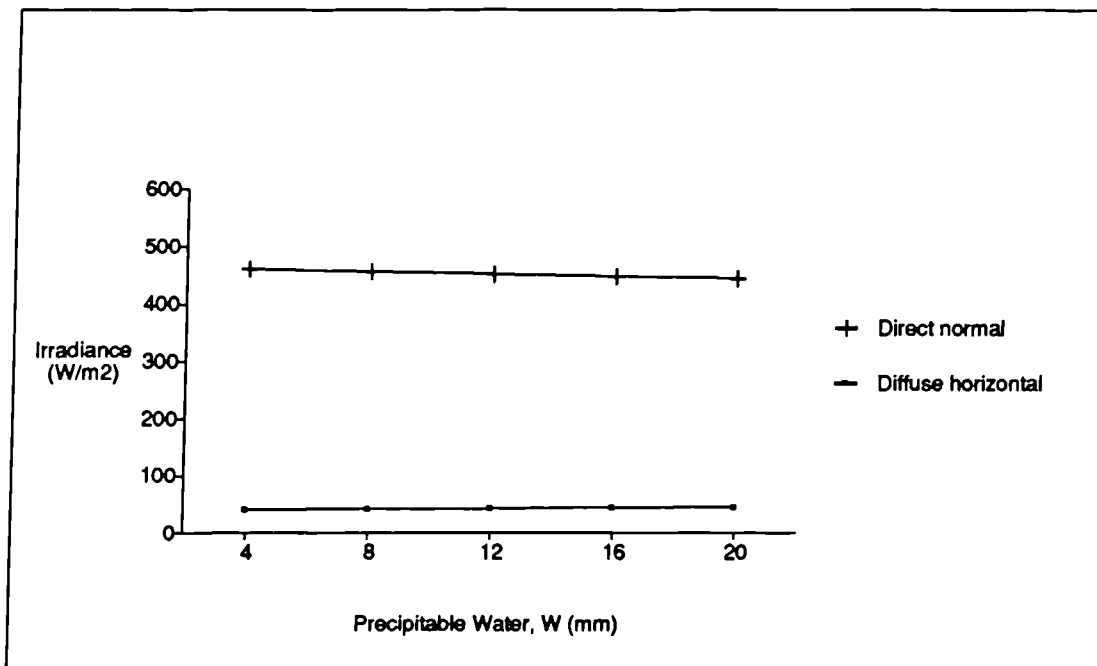

Figure B.1 The effect of variations in the level of atmospheric precipitable water content on the amount of radiation (daily mean, 15th of July) received at the earth surface.

(atmospheric turbidity coefficient ; $B = 0.105$)

As Angstrom's formulae are only very rough approximations, standard values of the turbidity coefficients for use in estimating the geographical distribution of solar radiation are given in the literature.

For localities located at 30°N with 900mb air pressure, the lower and upper limits suggested by Robinson [2] for B are 0.010 and 0.200 respectively.

As in clear skies both the direct and diffuse radiation received on the earth are primarily functions of solar altitude angle and the variations in solar intensities received by the earth due to the variations in W and B are relatively small [8], the mean (0.105) of the limits suggested by Robinson [2] for B was taken to represent the turbidity of the atmosphere of the City of Yazd.

The air mass (m), or the path length of the solar beam through the earth's atmosphere in equation B.1, is related to the solar altitude and site elevation such that;

$$m = \exp[h(-0.0017h - 0.1174)] / \sin a \quad (B.7)$$

Where h is the site elevation relative to sea level(Km), and a the solar altitude.

For altitude angles smaller than 10°, equation B.7 tends to become less accurate and so an alternative expression is suggested such that;

$$m = \exp[h(-0.0017h - 0.1174)] \exp[3.67985 + \sum_{i=1}^6 e_i (\sin a)^i] \quad (\text{B.8})$$

Where e is a constant as;

$$\begin{aligned} e_1 &= -24.4465 \\ e_2 &= 154.017 \\ e_3 &= -742.181 \\ e_4 &= 2263.36 \\ e_5 &= -3804.89 \\ e_6 &= 2661.05 \end{aligned}$$

The solar altitude, a , may be determined from;

$$a = \sin^{-1}[\cos(L)\cos(d)\cos(\theta_h) + \sin(L)\sin(d)] \quad (\text{B.9})$$

Where;

a is the solar altitude (radians)
 L is the site latitude (north positive, south negative)
 d is the solar declination (radians)
and θ_h is the hour angle (radians)

The solar declination, d , is determined from;

$$d = 23.45 \sin(280.1 + 0.9863 Y) \quad (\text{B.10})$$

Where Y is the year day number.

The hour angle, θ_h , in equation B.9 is the angular expression of solar time and is positive for times before solar noon and negative for times after. It is found from;

$$\theta_h = 15(|12 - t_s|) \quad (\text{B.11})$$

Where t_s is the local apparent time or solar time. The relationship

between local mean (or clock) time, t_m , with the solar time is as follows;

$$t_s - t_m = + dl/15 + e_t + s \quad (\text{B.12})$$

Where dl is the longitude difference (degrees), e_t the equation of time (hours) and s the possible correction for daylight savings (hours).

The longitude difference, dl , is the difference between the observer's actual longitude and the longitude of the mean or reference meridian for the local time zone. The difference is positive for locations to the west of the reference meridian and negative to the east. For Iran the reference meridian is the meridian of the capital, Tehran. The difference between the longitude of the city of Yazd and Tehran is about - 3.5 degrees.

The equation of time makes allowance for the observed disturbances to the earth's rate of rotation and can be determined from;

$$e_t = 9.87 \sin(1.978 Y - 160.22) - 7.53 \cos(0.989 Y - 80.11) - 1.5 \sin(0.989 Y - 80.11) \quad (\text{B.13})$$

Where Y is the year day number.

B.2.2 DIFFUSE HORIZONTAL INTENSITY

With regard to diffuse horizontal intensities under cloudless sky conditions Rodgers et al [3], based on the work by Parmelee [9] which established that for a fixed solar altitude (a) there exists a linear relationship between diffuse horizontal and normal irradiance, have produced the following expression:

$$I_{fh} = 2 + \left(\sum_{i=1}^7 f_i (a/10)^i \right) \{ 1 + 0.033 \cos[(360 - Y)/370] \} - \left(10^{-3} \sum_{i=0}^5 g_i (a/10)^i \right) I_{dn} \sin a \quad (\text{B.14})$$

Where I_{fh} is diffuse horizontal radiation (W/m^2), I_{dn} is direct normal radiation (W/m^2). f and g are constants as given in table B.3.

Table B.3 Constants f and g for use with equation B.14

i	0	1	2	3	4	5	6	7
f		47.3820	29.6710	-15.8621	4.3463	-0.57764	0.03472	-0.0007362
g	297.0	1.8313	-3.7082	4.1233	-0.6409	0.02855		

Figure B.2, as an example, illustrates the calculated direct normal and diffuse horizontal radiation for the 15th of July.

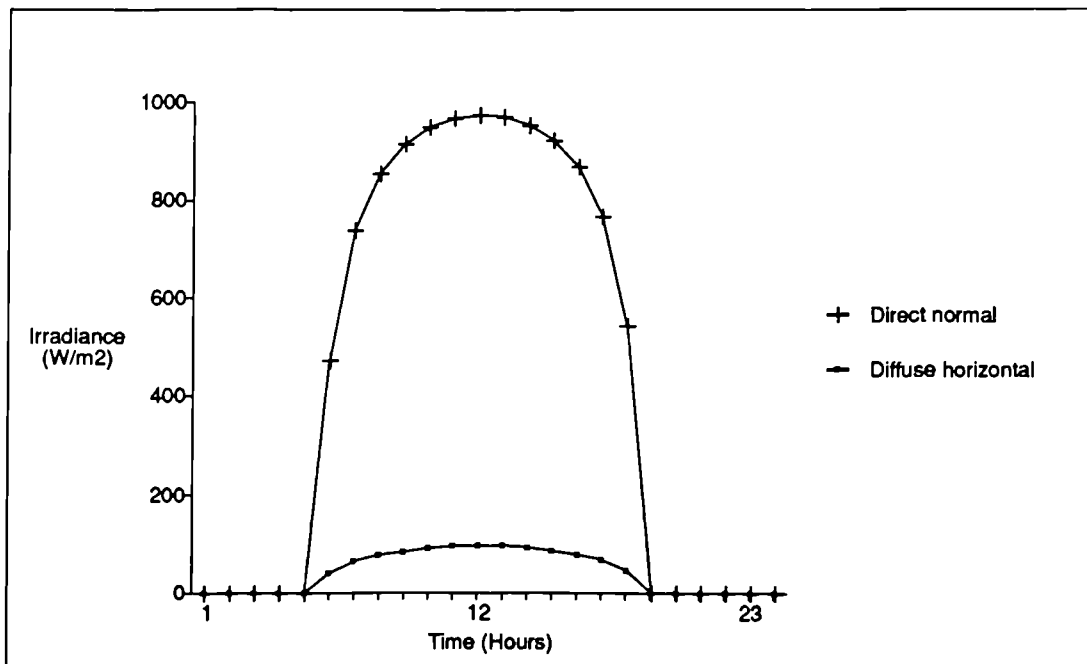

Figure B.2 Direct normal and diffuse horizontal radiation on the 15th of July.

B.3 ESTIMATION OF HOURLY VALUES FOR AIR TEMPERATURE, RELATIVE HUMIDITY, WIND SPEED AND DIRECTIONS

As the sinusoidal temperature distribution for the ambient air is usually sufficient for building energy analysis [10], sine wave curve fitting techniques were used to obtain hourly ambient air temperatures. This is a procedure widely used in practice and is included in many associated environmental computer programs. The same exercise was carried out to obtain hourly relative humidities.

Synthetic boundary conditions for a representative day of each month were constructed by interpolating a long term (1952-75) averaged values of monthly mean maximum and minimum air temperatures and relative humidities supplied by the Iranian Meteorological Organisation [11], assuming a sinusoidal variation exists. To estimate the 24 hourly values, the maximum and minimum values and the time of occurrence of the maximum value (the minimum value is assumed to occur 12 hours earlier) are interpolated as follows;

$$\text{Hourly values} = X_{mean} + X_{diff} * \sin ((15 * i) - X_{time}) \quad (\text{B.15})$$

Where:

$$X_{mean} = (X_{max} + X_{min})/2 \quad (\text{B.16})$$

$$X_{diff} = (X_{max} - X_{min})/2 \quad (\text{B.17})$$

Where:

X_{max} = monthly mean maximum temperature/relative humidity

X_{min} = monthly mean minimum temperature/relative humidity

$i = 1, 24$ time (hours)

$$X_{time} = 15 * X_{hour} \quad (\text{B.18})$$

Where:

$$X_{hour} = i_{max} - 6 \quad (\text{B.19})$$

Where:

i_{max} = time (hour) of the occurrence of maximum temperature/humidity.

It is assumed that the maximum values of air temperature and relative humidity occur at 15 and 03 hours respectively.

The monthly averaged (1952-75) wind speed together with the prevailing wind direction in that month were used to represent hourly wind data assuming there is constancy in wind patterns.

Table B.4 lists the values used in simulating the required hourly values of air temperature, humidity, wind speed and direction for this study. Figures B.3 and B.4 show the temperature and relative humidity profiles for the representative days in different months.

Inherent in the approach employed for estimating the hourly values of air temperatures, relative humidities and wind patterns in absence of such data, is the assumption that all days in a month have the same hourly values as the average. The disadvantage associated with this method, which may lead to disregarding the spread in daily values leading to misleading results by indicating, for instance, that no heating was needed during a month, whereas, in fact, some heating may have been required on days with weather more severe than the period average, is less problematic under the climatic conditions in hot arid zones where the climate is stable enough to produce many successive days with repetitive weather conditions (see Chapter 2) than for instance, in temperate climates, where the changes in daily weather conditions are significant.

Table B.4 Synoptic climatic data used for simulating the hourly values of air temperature, relative humidity, wind speed and direction.

Months	J	F	M	A	M	J	J	A	S	O	N	D
Monthly Mean Maximum	11.9	15.3	20.4	25.7	31.9	37.4	39.2	37.6	33.9	27.3	19.30	13.4
Monthly Mean Minimum	-0.9	1.8	6.6	11.7	17	21.8	23.9	21.4	16.9	10.3	4	-0.3
Monthly Mean Average	5.5	8.6	13.5	18.7	24.5	29.6	31.6	29.5	25.4	18.8	11.7	6.6

Temperature (c°)

Relative Humidity (%)

Monthly Mean Maximum	66	59	49	47	32	21	17	20	24	34	53	61
Monthly Mean Minimum	38	30	22	23	17	12	11	10	11	16	25	32
Monthly Mean Average	52	44.5	35.5	35	24.5	16.5	14	15	17.5	25	39	46.5

Wind

Monthly Mean Speed (m/s)	3.0	3.0	4.7	5.0	5.1	4.5	4.9	4.5	4.1	3.5	2.7	2.9
Direction: Degrees From North Clockwise	135	135	270	315	315	315	315	315	315	270	135	135

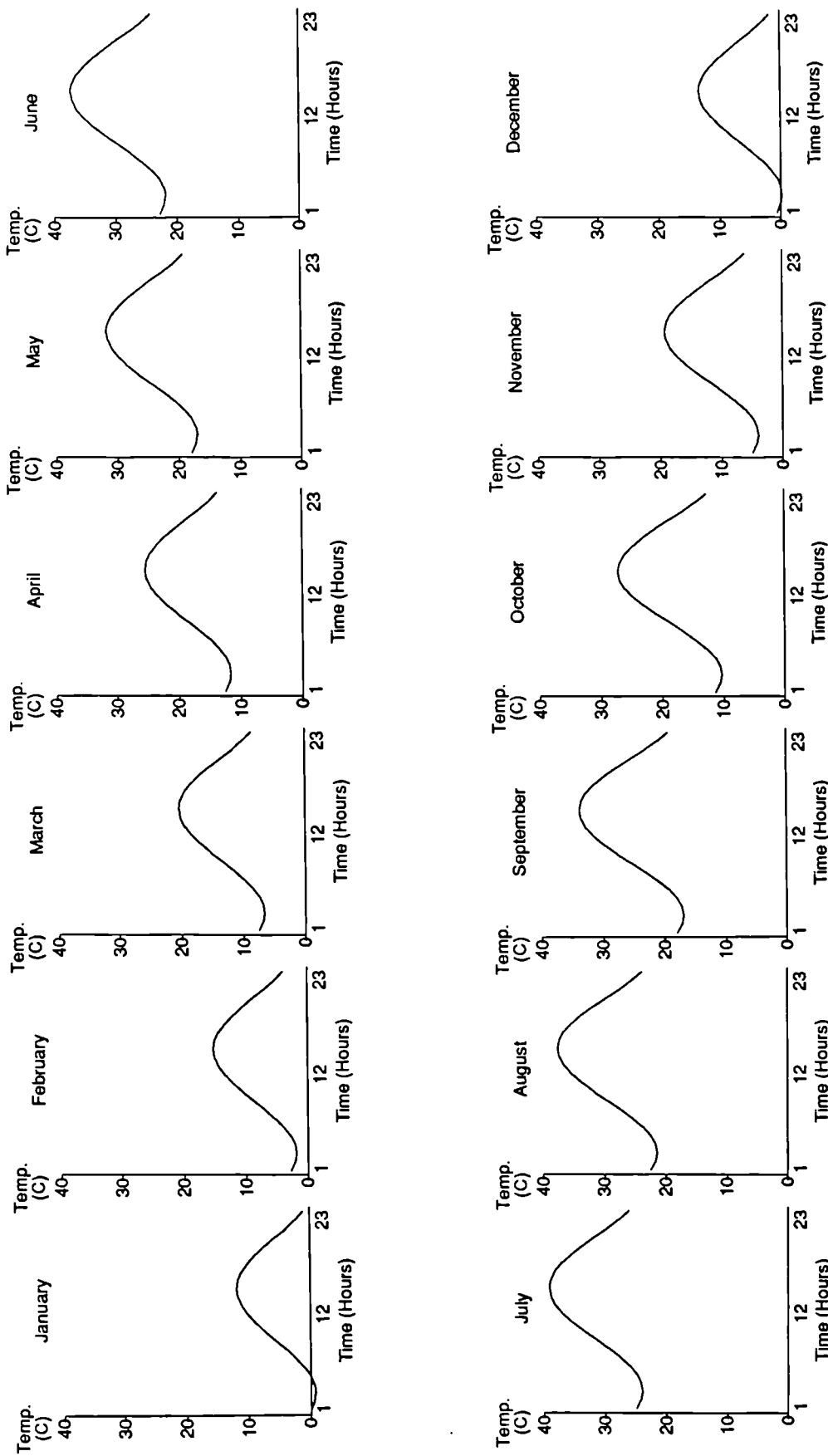

Figure B.3 Dry-bulb air temperature profiles

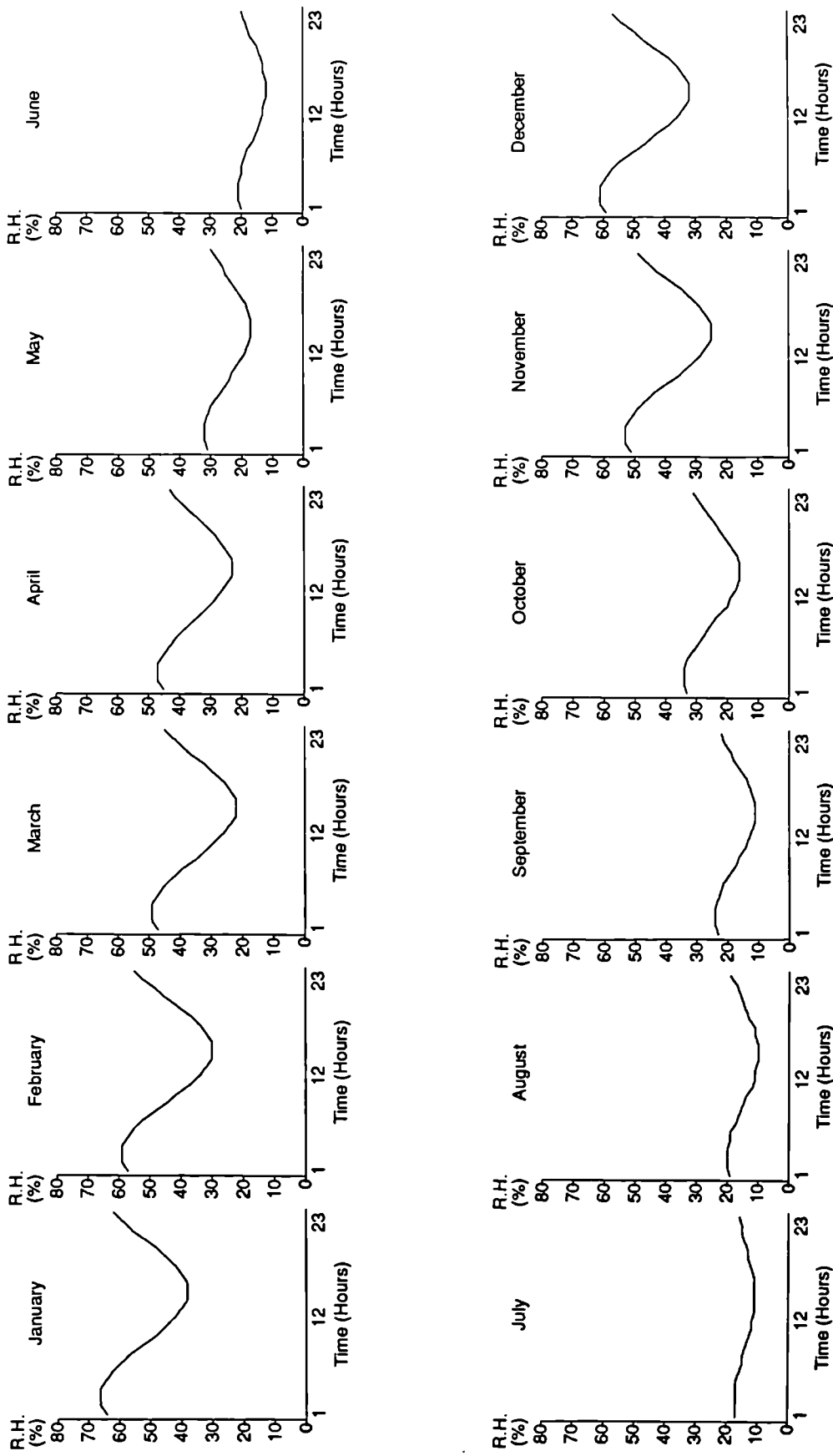

Figure B.4 *Relative humidity profiles*

B.4 REFERENCES

- [1] Koenigsberger, O.H. et al *Manual of tropical housing and building, Climate design.* Longman, 1973.
- [2] Robinson, N.(Ed.) *Solar radiation.* Elsevier Publishing Company, 1966.
- [3] Rodgers, G.G., Souster, C.G. and Page, J.K. *Development of an interactive computer program SUN1.* Rep. IRN BS28, University of Sheffield, 1978. [4] Clarke, J.A. *Energy simulation in building design.* Adam Hilger Ltd., 1985.
- [4] Clarke, J.A., *Energy simulation in building design.* Adam Hilger Ltd., 1985.
- [5] Iqbal, M. *An introduction to solar radiation.* Academic Press, 1983.
- [6] Leckner, B. *The spectral distribution of solar radiation at the earth's surface - Elements of a model.* Solar Energy, Vol. 20, No. 2, 1978.
- [7] *CIBSE GUIDE, Vol. C : Reference Data (C1).* The Chartered Institution of Building Services Engineers, London, 1986.
- [8] Paltridge, G.W. and Proctor, D. *Monthly mean solar radiation statistics for Australia.* Solar Energy, Vol.18, No. 3, 1976.
- [9] Parmelee, G.V. *Irradiation of horizontal and vertical surfaces by diffuse solar radiation from cloudless skies.* ASHVE Transactions, Vol. 60, 1954.
- [10] Bahadori, M.N. and Chamberlin, M.J. *A simplification of weather data to evaluate daily and monthly energy needs of residential buildings.* Solar Energy, Vol.36, No. 6, 1986.
- [11] Iranian Meteorological Organisation, *Tables of the averaged monthly climatic variables.*

Appendix C

Published papers

19-23 JUIN 1989

CIB 89

JUNE 19-23 1989

**XI^e CONGRES INTERNATIONAL
XIth INTERNATIONAL CONGRESS**

PARIS LA VILLETTE FRANCE

**LA QUALITE POUR LES USAGERS
DES BATIMENTS
A TRAVERS LE MONDE**

**QUALITY FOR BUILDING USERS
THROUGHOUT THE WORLD**

**CONSEIL INTERNATIONAL DU BATIMENT
POUR LA RECHERCHE L'ETUDE ET LA DOCUMENTATION**

**INTERNATIONAL COUNCIL FOR BUILDING RESEARCH
STUDIES AND DOCUMENTATION**

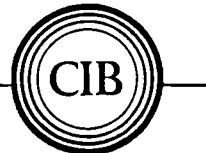

THE EFFECT OF MASS ON COMFORT AND ENERGY REQUIREMENTS IN HOT DRY CLIMATES

SODAGAR Behzad, WARREN Brian

University of Newcastle-upon-Tyne, United Kingdom

KEY WORDS

Computer simulation - Thermal capacity - Thermal performance - Thermal comfort - Energy conservation

ABSTRACT

The central theme of this paper is the effect of the thermal capacity of buildings on their thermal performance. Three identical buildings having different amount of thermal capacity seen from their interiors, identified as thermally heavy, thermally medium and thermally light were considered. Under the climate of the hot arid zone of Iran, the thermal performance of these buildings was simulated using an advanced computer programme. Two types of control regimes were considered; no temperature control (free-floating) and controlled internal environment using two thermostat set points; continuous and intermittent.

The annual energy requirements of buildings were in favour of thermally heavy buildings in the region of 5% to 10% depending on the control strategies. From the point of view of thermal comfort the thermally heavy buildings behave more satisfactorily both in the heating and cooling seasons. The study confirmed that thermally light buildings respond more rapidly to changes in energy output and are more prone to excessive temperatures.

L'EFFET DE LA CAPACITE THERMIQUE SUR LES BESOINS EN CONFORT ET ENERGIE DANS LES REGIONS DE CLIMAT CHAUD ET SEC

SODAGAR Behzad, WARREN Brian

Université de Newcastle-upon-Tyne, Royaume Uni

MOTS CLES

Simulation informatique - Capacité thermique - Performance thermique - Confort thermique - Economie d'énergie

RESUME

Le thème central de cette communication concerne les effets de la capacité thermique des bâtiments sur leur performance thermique. Trois bâtiments identiques ont constitué l'objet de cette étude. Vus de l'intérieur, ils ont des capacités thermiques différentes et sont identifiés, du point de vue thermique, comme étant lourds, moyens et légers. Sous le climat chaud et aride de l'Iran, la performance thermique des bâtiments en question a été simulée par l'utilisation d'un programme informatique avancé. Deux types de régime de contrôle ont été considérés : pas de contrôle de température (liberté de flottement) et contrôle de l'environnement interne par l'utilisation de deux thermostats, respectivement continu et intermittent.

Les besoins annuels des bâtiments en énergie étaient en faveur des bâtiments "thermiquement lourds", de 5 à 10% dans la région selon les stratégies de contrôle. Du point de vue confort thermique, les bâtiments thermiquement lourds se comportent de manière satisfaisante, au cours des deux saisons, chaude et froide. L'étude a confirmé que les bâtiments "thermiquement légers" répondent plus rapidement aux changements en production d'énergie et sont plus enclins aux températures excessives.

0.1 INTRODUCTION

The need to save energy has resulted in a large investment in research into the thermal performance of building constructions. In Northern Europe and the United States, this work has been mainly directed towards saving heating energy and as a consequence the way in which buildings behave in cold and temperate climates is fairly well understood. Designers of buildings are now able to assess the effects of thermally heavyweight or lightweight buildings under different heating requirements.

In certain areas of the world, however, such as Iran, the annual energy used to maintain thermal comfort in dwellings results from both a heating and cooling demand.

Generally, although the cooling season dominates the annual energy demand in buildings in these areas, the contribution of heating energy in the cold periods of the year may be considerable. If the annual energy used to maintain comfort is to be reduced then considerations must be given to building performance under both heating and cooling conditions.

0.2. RESEARCH OBJECTIVES

The authors' research is concerned with a variety of factors relating to thermal performance of buildings. In this context, a particularly interesting aspect is the effect of thermal capacity on the thermal performance of buildings. The main objectives of research reported in this paper are the followings :

- To study the effect of thermal capacity and the position of insulation within the building construction on energy consumption and thermal comfort.
- To study the interaction between different control strategies, building envelope and energy consumption of buildings.

0.3. METHODOLOGY

In order to achieve the objectives of this study, the investigations were carried out using a hypothetical model of a building representative of a typical house in Iran. The thermal performance of this building was then simulated using an appropriate building simulation computer package.

1. GENERAL CHARACTERISTICS OF HOUSES

Three buildings were used in this study. These buildings had the same floor plan and were identical except for the composition of the envelopes and the amount of thermal capacity provided in interior partitions. The plan of the hypothetical model representative of residential houses in the region, was simplified in such a way so that the thermal performance of identical rooms facing different orientations could be simulated (figure 1). This should lead to the results giving design guide lines in arranging the position of rooms within a building with respect to their functions.

While keeping the thermal resistance of the envelopes the same, the position of the insulation was changed to give three conditions which from the thermal response point of view were identified as ; heavy, medium and light. Internal walls having the same thermal resistance were changed from brick in the thermally heavy building, to light concrete in the thermally medium, to timber cavity wall with a 25 millimetres air space in the thermally light building. Constructions are shown in figure 2.

2. OCCUPANCY SCHEDULE AND INCIDENTAL GAINS

In this study it was assumed two persons would share a room. The occupant loading was assumed to be 95 Watts/Person sensible, 45 Watts/Person latent. An additional load of lights/appliances was assumed to be 200 Watts from 18 to 24 hours.

3. VENTILATION RATES

Generally speaking, it is advisable that the ventilation rate during summer days in hot arid zones should be kept to the absolute minimum necessary to control internal pollution. However, advantages can be obtained from nocturnal ventilation on cool summer nights which is the normal mode of operation.

The desirable rate of fresh air supply depends on the purpose for which the space is utilised, the number of occupants and their activities. In this study it was assumed that rooms with one window have an air change rate of 0.5 per hour and those with two windows have one air change per hour. This applies for 24 hours in the winter, for 24 hours in the summer with continuous cooling and for daytime only in the summer when intermittent cooling is used. When intermittent cooling is employed and the plant is off between 23.00 to 5.00 hours, an air change of 20 per hour was considered in all rooms when people would normally leave windows and doors open.

4. SIMULATION MODEL

The computer programme used in this study was Environmental Systems Performance (ESP). The programme was developed at the University of Strathclyde, U.K. and has undergone extensive third party validation. The dynamic heat flow through all solid boundaries is calculated by the finite-difference method and full account is taken of the thermal storage effect of the structure.

The following data is needed in order to run a simulation: details of building components and their distribution into zones, number of days for which simulation is to be run, internal loads, control strategies and 24 hourly value of climatic parameters including; ambient air temperature, direct solar radiation, diffuse horizontal radiation, wind speed and its direction and humidity.

5. CLIMATIC ENVIRONMENT

The main characteristics of the hot dry climates, have their origin largely in the solar radiation condition. Therefore, in these areas, the major function of the building envelope is to modify the daytime heating effect.

Little data on solar radiation is available in developing countries located in the hot arid belt of the world. Therefore, hourly solar intensities were calculated for the latitude in question under clear sky conditions. One of the characteristics of the site in question is having clear skies for most of the year. Therefore no correction was made to modify the calculated data for rarely cloudy conditions. Other climatic data such as ambient air temperature, humidity, wind speeds and their direction for the city of Yazd recorded by the Meteorological Department, Iran, have been adopted for this research.

6. SIMULATION RESULTS

To investigate the effects of thermal mass and its location, a group of simulation scenarios was run. Two important criteria in evaluating the scenarios are energy consumption and thermal comfort. The interior conditions are assumed to be described simply by the air temperature, i.e. it is assumed that there is a thermostat in each zone.

In this study two types of control regimes were considered. First of all no heating or cooling was supplied and the interior air temperature was allowed to float freely. Then, both winter time heating and summer time cooling were simulated. The heating season was assumed to run from November to March and the cooling season from May to September. During two months of the year, April and October, it was assumed that a comfortable environment inside buildings could be achieved by natural means and this assumption has been confirmed by the simulations.

For the plant operation two types of control strategy were considered; continuous and intermittent. Details are given in table 1.

6.1 NO TEMPERATURE CONTROL (free-floating)

The air temperature changes under free floating conditions are the result of instantaneous energy gains or losses by the interior. Thermal characteristics of the envelope influence the energy flow through it, and thermal characteristics of internal partitions govern the energy gain or loss by the air inside.

With multi-layer constructions, internal temperature swings are determined primarily by the characteristics of the materials in the layers next to the internal surface. Therefore, when lining the external walls with insulation on the internal surface, the insulation layer prevents the variable heat energy from getting into the heavy weight layer, and as a result, the heavy weight layer tends to have a relatively small damping effect. It is this characteristic which leads the composite structure to react in a similar manner to a thermally light structure

Internal air temperatures were calculated and, as an example, the results for the south facing rooms (zone 2) on a summer day, 15th of June, and a winter day, 15th of February were plotted in figure 3. The temperature profiles show thermally light buildings respond more rapidly to changes of energy loss or gains. Therefore, it can be concluded that both envelope mass (seen from interior) and interior mass have the capability of smoothing out temperature fluctuations in a building whose interior air temperature is allowed to float. The other characteristic of thermal capacity of a structure is that it provides a lag between

the time of energy output and its effects to be observed. These are well known results.

6.2 CONTROLLED INTERNAL ENVIRONMENT.

For each control strategy and for the whole of the heating and cooling seasons the whole house energy requirements were calculated.

6.2.1 YEARLY COOLING LOADS : From figure 4, it can be concluded that for the situation considered the thermally heavy building is the most energy efficient structure for cooling and heating whether continuous or intermittent. There is a calculated increase in the cooling loads of the thermally medium and thermally light building to the thermally heavy building of 0.2% and 0.6% respectively when continuous cooling is applied. When intermittent cooling is employed these ratios are 1% and 6% respectively. The greater differences in cooling loads in favour of the thermally heavy building with intermittent cooling indicates that advantage can be made from nocturnal ventilation as the result of the presence of mass.

6.2.2 YEARLY HEATING LOADS: The yearly heating loads are more responsive to the modifications in the envelope although they are smaller in magnitude than the cooling loads. With continuous heating, the annual heating loads of the thermally medium and light buildings were 2% and 28% in excess of that of the thermally heavy building respectively. With intermittent heating these were reduced to 1% and 23%. These decreases in differences between the heavy and light constructions are partly due to the effect of night setback and partly to the storage effect of the mass. It must be noted that the effect of mass also depends on the zone orientation. For west and north orientations lightweight zones show a slight advantage due to the reduction in solar radiation during early daytime hours.

6.2.3 YEARLY TOTAL LOADS: With continuous operation (heating and cooling) the annual energy requirements of the thermally medium and light buildings are 0.6% and 5% in excess of that of the thermally heavy building respectively. With intermittent operation these are 1% and 9% respectively.

7. COMFORT CONSIDERATIONS

From the point of view of thermal comfort the thermally heavy building behaves more satisfactorily both in the heating and cooling seasons. Temperature profiles of different zones showed that thermally lighter buildings respond more rapidly to changes in the external environment and internal incidental gains. The frequency of excessive temperatures during the winter in intermittently heated houses was calculated and are shown in table 2. As this table shows the frequency of overheating is greatest for the lightweight building and least for the heavyweight.

In the cooling season although the internal air temperatures of houses were almost always at thermostat set point temperature, 22 degrees celsius during the days, higher mean radiant temperatures were measured in the lighter buildings. With intermittent cooling, during nights when nocturnal ventilation was provided, the internal temperature of houses was 2 or 3 degrees celsius above the night time temperature.

A very small difference in internal night time air temperatures in favour of the thermally light building was noticed but the difference in most cases would be too small to have any effect on the thermal sensation of the occupants.

8. CONCLUSIONS

The basic results from simulations run in this study indicate that although the main concern in the climate under investigation is cooling, heating requirements of buildings are significant. A building with a high thermal capacity seen from the interior is more energy efficient and can take advantage of diurnal changes by storing energy and delaying the effect of changes. The energy consumed in each zone to keep it at controlled conditions in the heating and cooling season was also calculated in order to show the effect of orientation on energy consumption. As it is generally acknowledged the optimal orientation for space heating in the northern hemisphere is towards south. In the cooling season however, north facing rooms are cooler and need less energy.

Differences in heating and cooling loads of zones facing different orientations indicate that the whole house annual energy consumption would be minimum if more spaces could be faced towards south orientation, i.e. a rectangular shaped building. The relations between the sides of the rectangle and factors such as windows size, shading, colour of the external surfaces, etc. all affect thermal performance of buildings and are areas of research that the authors are concerned with.

9. REFERENCES

- 1- Bruch, D M A field study of the effect of wall mass on the heating and cooling loads of residential buildings. Proceedings of the thermal mass seminar, June 1982, Knoxville, USA.
- 2- Catani, M J and Goodwin, S E Heavy building envelopes and dynamic thermal response. American Concrete Institute Journal. vol 73 (2), 1976.
- 3- Dougall, R S and Goldthwait, R G Effect of interior partitions and thermal mass in modelling small homes with an hour - by - hour computer program. Heat transfer in energy conservation, American Society of Mechanical Engineers, 1977.
- 4- Hopkins, V, Gross, G and Euifritt, D Comparing the thermal performance of buildings of high and low masses. ASHRAE Conference, Philadelphia 1979, Paper No 2 PH-79_11.
- 5- Mitalas, G P Effect of building mass on annual heating energy requirement. CIB International symposium on energy conservation in the built environment. Copenhagen, 1979.
- 6- White, D Interactive systems for the reduction of heating and cooling loads in dwelling. CIB International symposium on energy conservation in the built environment. Copenhagen, 1979.

TABLE 1
Thermostat set point schedules

Heating season	Cooling season
Continuous heating : at 20 C	Continuous cooling : at 22 C
Intermittent heating : 5.00 - 9.00 at 20 C 9.00 - 15.00 off 15.00 - 23.00 at 20 C 23.00 - 5.00 at 15 C	Intermittent cooling: 5.00 - 23.00 at 22 C 23.00 - 5.00 off

TABLE 2
Frequency of excessive temperatures occurring
in different zones in winter (t>24C)

Thermally heavy building	492 hours
Thermally medium building	608 hours
Thermally light building	1571 hours

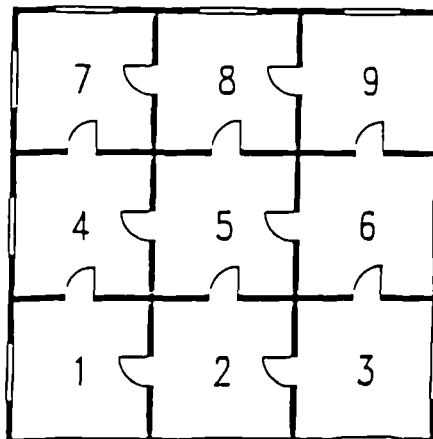

NOTES.

ROOM DIMENSIONS:	5.00m x 5.00m
FLOOR - CEILING HEIGHT	3.00m
WINDOWS.	WIDTH 2.00m
	SILL HEIGHT 1.00m
	HEAD HEIGHT 2.50m
DOORS.	WIDTH 1.00m
	HEIGHT 2.00m

FIGURE 1
Floor plan

FIGURE 2
Construction details of houses

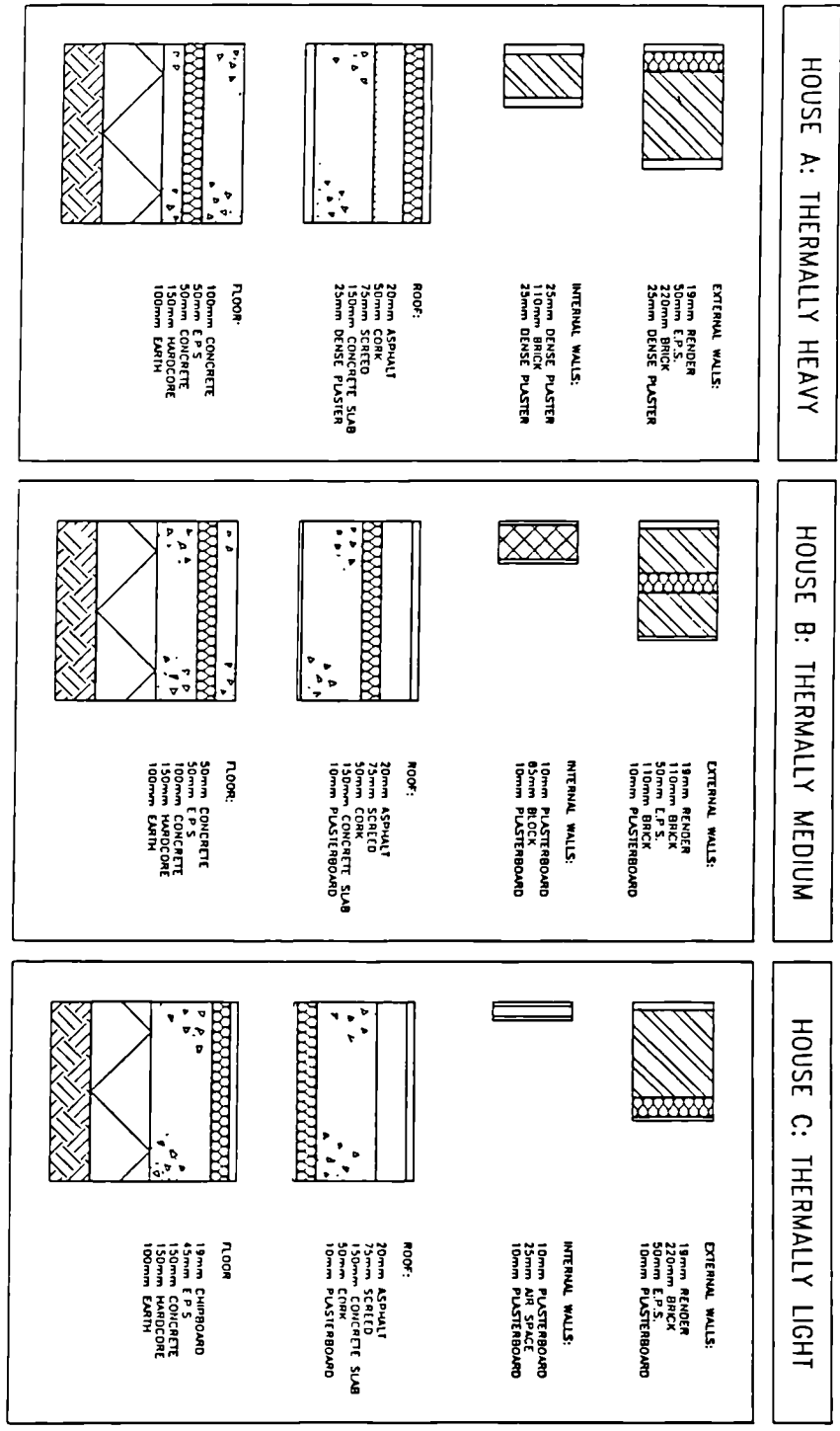

FIGURE 3
Air temperature in zone 2 in summer and winter
(free - floating)

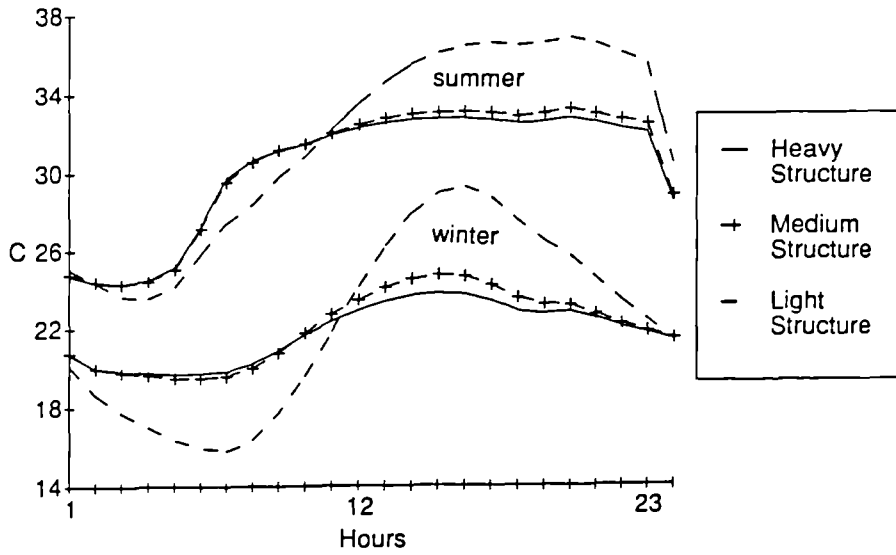
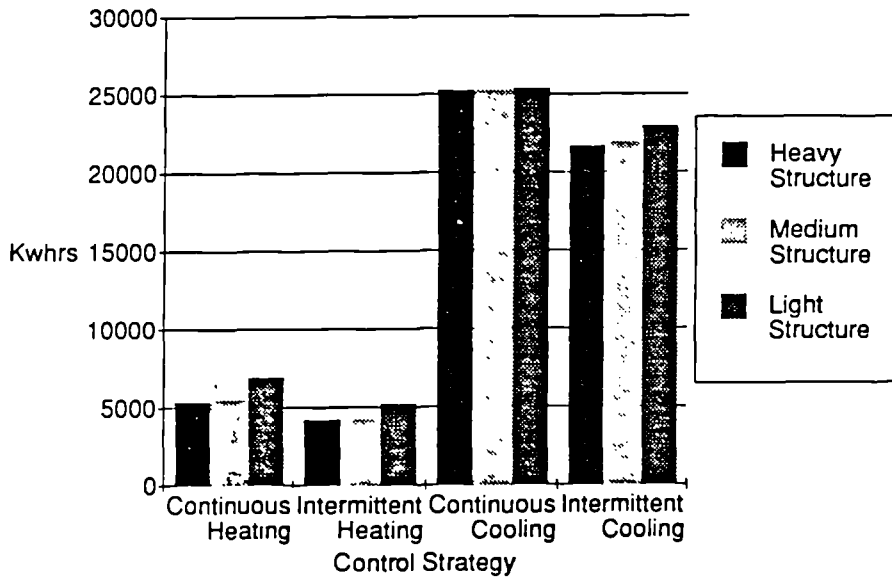

FIGURE 4
Annual energy requirements



International CIB W67 Symposium on

Energy, Moisture and Climate in Buildings

3 - 6 September 1990
Rotterdam The Netherlands



NOVEM (Netherlands Agency for Energy and the Environment)



Netherlands Ministry of Housing, Physical Planning and Environment

RANK XEROX

Rank Xerox

WINDOW DESIGN IN HOT DRY CLIMATES

B. Sodagar, B.F. Warren
University of Newcastle upon Tyne
Newcastle upon Tyne, United Kingdom, NE1 7RU

ABSTRACT

The choice of fenestration for a building can significantly affect its thermal performance. In Northern Europe, the main thrust of energy saving measures in houses is directed towards the heating energy consumed during the winter months. In this situation a cooling load rarely exists. In hot dry climates, the situation is different and the climates are often such that both cooling and heating seasons have to be considered. This requires the optimisation of not only the building fabric, but also the choice of heating and cooling systems and fuels. The economic analysis is made more complex where the cost of gas and electricity are widely different. The results of a parametric study of the dependence of energy and environmental performance of a single storey nine zone dwelling on glazed area and shading devices are reported in this paper.

INTRODUCTION

An investigation is currently being carried out in the school of architecture of the University of Newcastle upon Tyne, U.K. into the effects on energy use of varying the thermal performance of houses in hot dry climates using ESP computer program. The program was developed at the University of Strathclyde, U.K. and has undergone extensive third party validation. The dynamic heat flow is calculated by the finite difference method.

HOUSE TYPE

A single storey nine zone dwelling (Fig 1), is being studied using basic weather data from Iran. Since one can have an infinite number of combinations of such aspects as window design, material and fabrications, the scope of the work has been limited to modelling what is considered to be practicable and reasonable. The external walls of the house are 220mm brickwork plastered internally. The floor is concrete on the grade and the roof is a traditional warm roof consisting of concrete slab insulated externally and topped with screed and asphalt. Internal partitions are 110mm brickwork plastered on both sides. The glass chosen is a single pane of 4mm clear float which is the most common and available glass used in the housing industry.

MODELLING CONTROL CONDITIONS

Previous studies had established that for the particular climate under

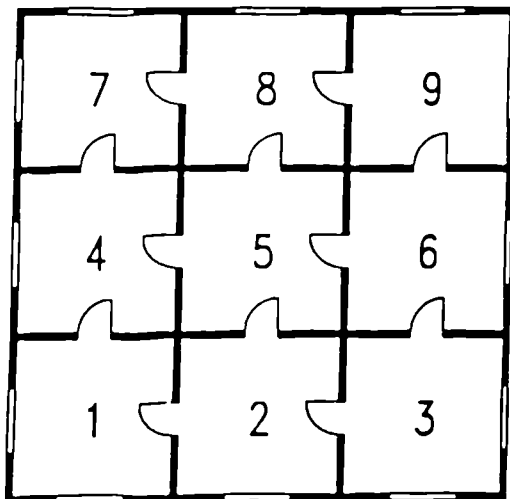

NOTES:

ROOM DIMENSIONS:	5.00m x 5.00m
FLOOR - CEILING HEIGHT	3.00m
WINDOWS:	2.00m
WIDTH	2.00m
SILL HEIGHT	1.00m
HEAD HEIGHT	2.50m
DOORS:	1.00m
WIDTH	2.00m
HEIGHT	

FIGURE 1. Floor plan of the reference house

consideration, the heating season effectively consisted of the months from November to March and the cooling season the months from May to September. During April and October, the weather is such that mechanical heating or cooling would not normally be required.

For both the winter and summer, temperature and ventilation regimes were chosen which were considered to be representative of common practice (Table 1).

RESULTS

In order to examine the effect of window size and its orientation on energy demands of spaces, four rooms of the reference house facing four cardinal orientations were considered, zones 2, 4, 6 and 8. It was assumed that there is no heat flow through internal partitions, i.e. rooms are surrounded by thermally identical rooms. Window design of these rooms was changed. Different areas of glazing were obtained by

TABLE 1. Thermostat set point schedules and ventilation rates

HEATING SEASON			COOLING SEASON		
Time	Controlled Temps.	Ventilation rate ac/h	Time	Controlled Temps.	Ventilation rate ac/h
05 - 09	20°C minimum	1	05 - 23	22°C maximum	1
09 - 15	system off	1	23 - 05	system off	20
15 - 23	20°C minimum	1			
23 - 05	15 (set back)	1			

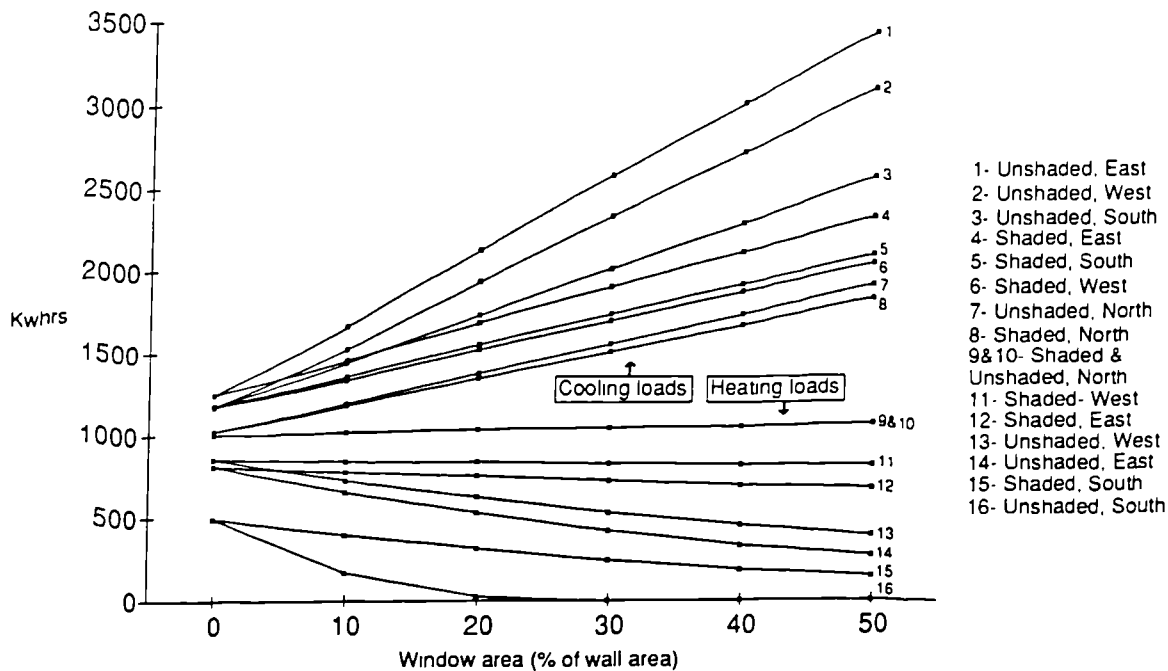

FIGURE 2. The effect of window size and shading on loads

changing the window width whilst keeping the height at a constant 1.5 metres. Changing the width from 1 to 5 metres in increments of 1 metre gives window to wall ratios of 10, 20, 30, 40 and 50 percent respectively. In all cases windows were located centrally on the external walls with a constant window sill height of one metre. Rooms without any windows were also investigated for comparison.

To evaluate the performance of fixed external shading devices, in the first instance the method of Olgyay (1) was used to estimate the size of devices. In our simulation runs it was imposed that the shadow of the device would cast only on the glazing and would not stretch to adjacent fabrics, i.e. fine louvers and/or vertical fins were used. The effect of devices was limited only to intercepting the direct solar radiation, therefore any other heat exchanges which might take place between devices and windows, i.e. by radiation or convection were neglected.

Cooling and heating requirements of rooms with different glazing without shading devices and those with devices designed using the method of Olgyay are shown in Figure 2.

The cooling requirements of north facing rooms are minimal as they do not receive a great quantity of direct solar radiation. Consequently, shading windows does not provide significant reduction in cooling loads. Since in the site in question, latitude 32N, windows facing north do not receive any sun shine during the heating season, i.e. from November to March, one line represents the heating requirements of rooms with and without shading devices (Fig 2).

The effect of window size and shading is quite significant on the

thermal performance of rooms facing east and west. Any increase in the glazing area will increase the cooling loads substantially. Shading the windows in summer is very effective in reducing the cooling loads. Providing shading on windows comprising, i.e. 20% of the wall area would decrease the cooling requirements by 20.6% and 20.1% for the east and west orientations respectively. The corresponding percentages for the south and north facing windows are only 10.2% and 2.2% respectively.

Because of the abundance of sunshine, except for rooms facing north, increasing the window areas reduces the heating requirements. Heating loads are increased in presence of shading devices as they obstruct some of the winter sun's rays. Large south facing windows appear to be very efficient in winter as they can harvest a great quantity of solar radiation.

The annual cooling and heating loads represent the energy that has to be extracted and added respectively and are not energy consumptions. Energy consumptions will depend on the refrigeration system coefficient of performance and the heating system efficiency.

In terms of economics, changes in loads need to be considered with respect to their ultimate impact on purchasing energy. The designer of a house and its ultimate occupier will be concerned with running costs and the cost effectiveness of any modification in the design of the building. It is of use, therefore, if the energy consequences of changing the window design can be expressed in terms of cost.

If the annual cooling load is given by L_c Kwhrs, the heating load L_h Kwhrs, then the total annual energy requirements, Q_t , is given by:

$$Q_t = L_c / \text{cop} + L_h / f \quad \text{Kwhrs} \quad (1)$$

Where cop is the coefficient of performance of the cooling system and f the overall efficiency of the heating system. Typically for Iran the cooling system is electricity driven whilst gas is used for heating. If the cost of electricity is C_e per Kwhrs and that of gas C_g per Kwhrs, the total annual cost C_t is given by:

$$C_t = (L_c / \text{cop}) * C_e + (L_h / f) * C_g \quad (2)$$

This can be written as:

$$C_t / C_g = (L_c / \text{cop}) * N + (L_h / f) \quad (3)$$

Where N is the ratio of electricity cost to gas cost, C_e / C_g .

Values of cop , f and N vary depending on the efficiencies of the refrigeration system, heating system and the local prices of fuels respectively. By assuming that values of cop may vary between 2 and 3, and those of f between 0.6 and 0.8, and N between 3 to 6 different scenarios may be considered. We considered 3 scenarios. In scenario 1 (SC1), we took middle range of variables, i.e. values of 2.5, 0.7 and 4.5 for cop , f and N respectively. By substituting these values in equation 3 we will have:

$$C_t / C_g = 1.8 L_c + 1.43 L_h \quad (4)$$

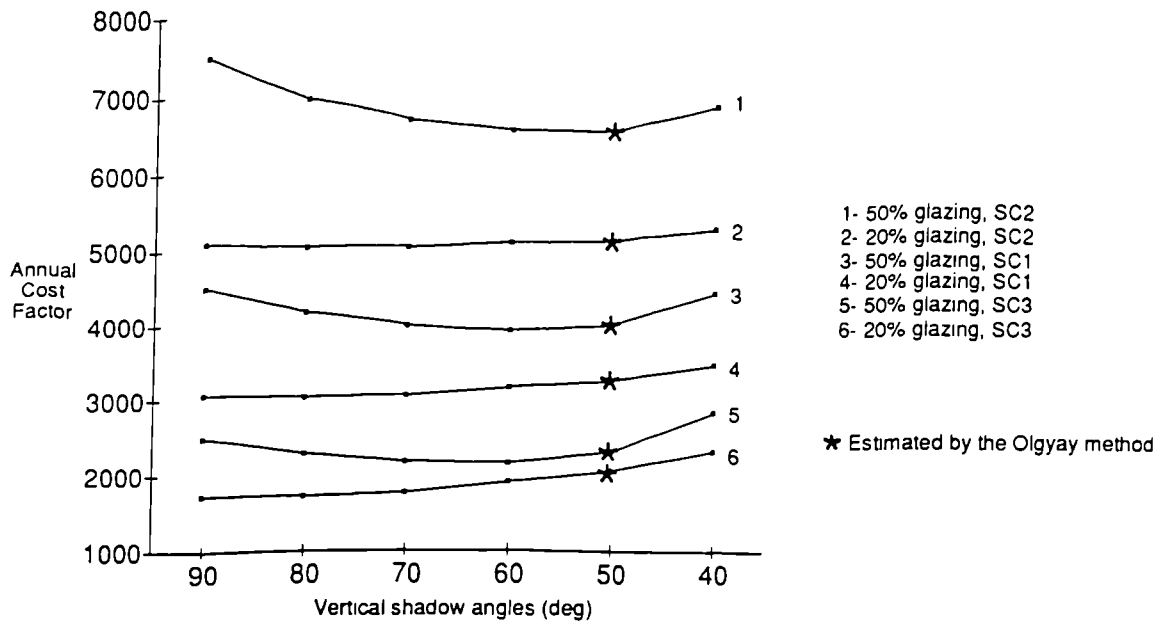

FIGURE 3. Fenestration cost analysis for south facing room

Scenario 2 (SC2) was in the favour of heating loads. i.e. values of 2, 0.8 and 6 were chosen for cop, f and N respectively. And finally in scenario 3 (SC3), values of 3, 0.6 and 3 were assigned for cop, f and N respectively. By substituting these values in equation 3, we should have:

$$Ct/Cg = 3 Lc + 1.25 Lh \quad \text{for SC2} \quad (5)$$

and :

$$Ct/Cg = Lc + 1.67 Lh \quad \text{for SC3.} \quad (6)$$

The cost effectiveness of changes in window design now can be cast into values of Ct/Cg designated as Annual Cost Factor (Ct/Cg = ACF).

In order to investigate the effect of the size of shading devices on energy consumption and consequently the cost of conditioning houses, the design of shading devices of two windows comprising 20 and 50% of the wall area was modified. The results for the south facing windows are plotted in Figure 3. One can see that the size of the shading devices estimated by the Olgay method is overestimated under any scenario. The results for east and west orientations were more satisfactory.

From results obtained, the fenestration design of the reference house (Fig 1) was changed. Windows comprising 20% of the wall area seem to be appropriate to satisfy visual comfort while being reasonably efficient in energy terms. Windows facing east and west in four corner rooms, zones 1, 3, 7 and 9, were eliminated due to their poor thermal performance. Since shading on windows facing north does not reveal significant savings, no devices were considered for these windows.

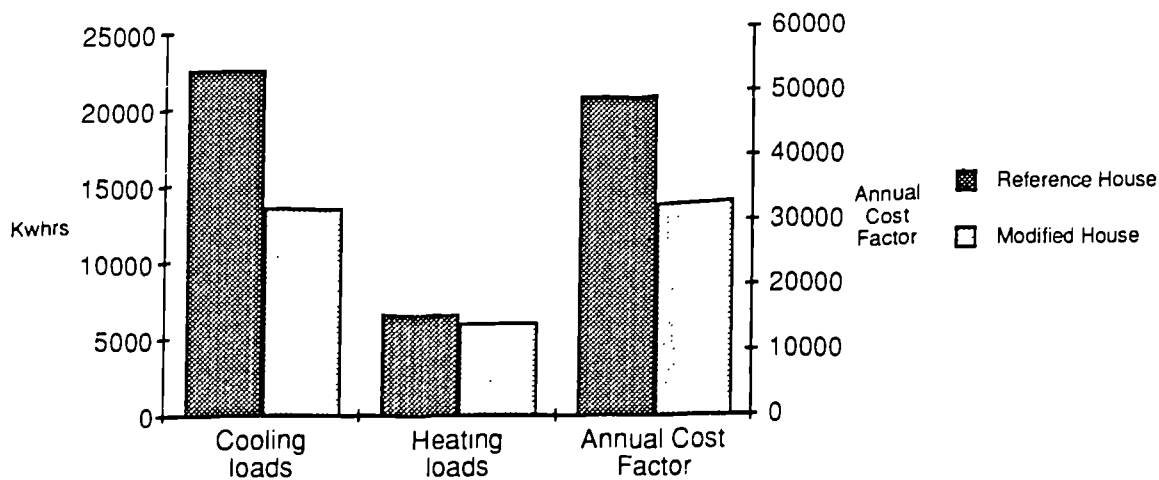

FIGURE 4. The effect of fenestration design on loads and costs

Horizontal shading devices bearing a vertical shadow angle of 70 degrees were placed over south facing windows, and those with an angle of 35 degrees on east and west facing windows.

Annual heating and cooling loads together with the Annual Cost Factors of the house with the new window arrangement were calculated under scenario 1 and are shown together with those of the reference house in Figure 4. A substantial saving in the annual running cost as much as 34% can be achieved under the new design strategy.

CONCLUSIONS

The results of a parametric study of the dependence of energy performance of a single storey residential prototype on fenestration design was reported in this paper. ESP computer programme was used to analyse the variations in heating and cooling loads due to changes in orientation, size and shading of windows. Substantial savings in the annual running cost of buildings can be achieved under appropriate window arrangements. The simple graphical methods for estimating the size of shading devices, i.e. the Olgay method may over-estimate the size of the device.

REFERENCES

- (1) Olgay, A. and Olgay, V., Solar control and shading devices. Princeton University Press, 1957.
- (2) Sodagar, B. and Warren, B.F., The effect of mass on comfort and energy requirements in hot dry climates. Proc, XIth International Congress on the Quality for Building Users Throughout the World, User Comfort, Paris 1989, CIB. Theme I, Volume II, pp 255-264.
- (3) McKennan, G.T., Building energy needs and window area. BSER&T, Vol 6, 1985.

Bibliography

Adle, A.H. *Climate and vegetation in Iran*. University of Tehran, 1960. (in Farsi)

Ahmad, A.M. *The thermal performance of concrete roofs and shading panels under arid summer conditions*. Building Research Establishment, Overseas building notes, No. 164, October 1975.

Akbarzadeh, A. and Ahmadi, G. *Computer simulation of the performance of a solar pond in the southern part of Iran*. Solar Energy, Vol. 24, 1980.

American Society of Heating, Refrigerating, and Air Conditioning Engineers, ASHRAE. *Handbook of Fundamentals*, New York, 1977.

Aronin, J. *Climate and architecture*. Reinhold Corp. New York, 1953.

Arumi, F.N. *Thermal inertia in architectural walls*. National Concrete Masonry Association, USA, 1977.

Arumi, F.N. and Burch, D.M. *DEROB simulation of the NBS thermal mass buildings*. ASHRAE Transactions. Vol.90, Part 2B, 1984.

Bahadori, M.N. *A feasibility study of solar heating Iran*. Solar Energy, vol. 15, 1973.

Bahadori, M.N. *Conceptual development of a solar town in Iran*. Solar Energy, Vol. 23, 1979.

Bahadori, M.N. and Chamberlin, M.J. *A simplification of weather data to evaluate daily and monthly energy needs of residential buildings*. Solar Energy, Vol. 36, No. 6, 1986.

Baker, M.C., *Roofs: Design, Application and Maintenance*. Multiscience Publications, Canada, 1980.

Barry, R.G. and Chorley, R.J. *Atmosphere, weather, and climate*. Methuen, 1987.

Basnett, P. *Thermal capacity and energy requirements in well insulated houses*. Proceedings of the 2nd international symposium on energy conservation in the built environment. Copenhagen 1979.

Baxter, A.J. *Windows and energy*. Proceedings of the second international CIB symposium on energy conservation in the built environment. Copenhagen 1979.

Berglund, L.G., Gonzalez, R. *Human response to temperature drifts*. ASHRAE Journal, August 1978.

Bernatzky, A. *The contribution of trees and green spaces to a town climate*. Energy and Buildings, Vol.5, 1982.

Bitan, A. *The Jordan valley project - a case study in climate and regional planning*. Energy and Buildings, Vol.4, No.1, 1982.

- Bitan, A. and Assif, S. *Climatic data analysis and its use and representation for planners*. Energy and Buildings, Vol. 1, 1984.
- Bowman, N.T. and Lomas, K.J. *Empirical validation of dynamic thermal computer models of buildings*. Building Services Engineering Research & Technology, Vol.6, No.4, 1985.
- Building Research Establishment, BRE. *Glasgow commercial building monitoring project, Final Report for Annex IV on energy conservation in building and community systems*. 1980.
- Building Research Establishment, BRE. *Exploiting sunshine in house design*. May 1988.
- Burch, D.M., Krintz, D.F. and Spain, R.S. *The effect of wall mass on winter heating loads and indoor comfort - an experimental study*. ASHRAE Transactions, Vol. 90, part 1B, 1984.
- Burch, D.M., Malcolm, S.A. and Davis, K.C. *The effect of wall mass on the summer space cooling of six test buildings*. ASHRAE Transactions, Vol.90, part 2B, 1984.
- Byrne, S.J. and Ritschard, R.L. *A parametric analysis of thermal mass in residential buildings*. Proceedings of the ASHRAE/DOE/BTECC conference on the thermal performance of the exterior envelopes of buildings III, Florida, USA, December 1985.
- Catani, M.J. *Insulation and the M Factor*. ASHRAE Journal, Vol. 20, No. 6, 1978.
- Catani, M.J. and Goodwin, S.E. *Heavy building envelopes and dynamic thermal response*. American Concrete Institute Journal, Vol. 73(2), February 1973.
- Chandra, S., Fairey, P. and Houston, M. *A handbook for designing ventilated buildings*. Department of Energy, Final report (FSEC-CR-93-83), 1983, U.S.A.
- Childs, K.W. *The influence of thermal mass on building energy usage*. Proceedings of the building thermal mass seminar. June 1982, Knoxville, Tennessee, USA.
- CIBSE GUIDE, The Chartered Institution of Building Services Engineers, London, 1986.
- Clarke, J.A. *Energy simulation in building design*. Adam Hilger Ltd. 1985.
- Danby, M. *The design of buildings in hot dry climates and the internal environment*. Built International, 6, 1973.
- Dexter, M.E. *Including mass and insulation in building walls*. ASHRAE Journal, March 1980.

- Dougall, R.S. and Goldthwait, R.G. *Effects of interior partitions and thermal mass in modelling small homes with an hour-by-hour computer program.* American Society of Mechanical Engineers, 1977.
- Enis, R. *Landscape and climate - the interdependence of some of their factors.* Energy and Buildings, Vol.7, 1984.
- Etzion Y. *Design of shading devices using a one point method. A technical communication.* Energy and Buildings, 8, 1985.
- Fairey, P.W., Kerestecioglu, A.A. and Chandra, S. *Ventilative cooling in southern residences: A parametric analysis.* Proceedings of the ASHRAE/DOE/BTEE Conference on the Thermal Performance of the Exterior Envelopes of Buildings III, December 1985, Florida, U.S.A.
- Fanger, P.O. *Thermal comfort, Analysis and application in environmental engineering.* McGraw-Hill Book Company, 1970.
- Fanger, P.O. *Conditions for thermal comfort - A review.* Proceedings of the CIB commission W45 (Human requirements) symposium, BRE, 13-15 Sept. 1972. Thermal comfort and moderate heat stress, BRE report 2, HMSO, London, 1973.
- Fanger, P.O. *Thermal comfort in indoor environments.* Proceedings of symposium on thermal analysis - human comfort - indoor environments. National Bureau of Standards, Maryland, USA, 11 February, 1977.
- Gagge, A.P., Burton, A.C., Bazett, H.C. *A practical system of units for the description of the heat exchange of man with his environment.* Science, Vol.94, 1941.
- Givoni, B., *The effect of roof construction upon indoor temperatures.* Biometeorology, proceedings of the second international bioclimatological congress, London, September 1960.
- Givoni, B. *Man, climate and architecture.* Elsevier publishing Company, 1969.
- Givoni, B. *Options and applications of passive cooling.* Energy and Building, 7, 1984.
- Goodwin, S.E. and Catani, M.J. *The effect of mass on heating and cooling and on insulation requirements of buildings in different climates.* ASHRAE Transactions, Vol. 85, Part 1, 1979.
- Gough, M. *ESP simulation of Canadian direct gain test cell - Report for the International Energy Agency Task VIII, Sub-Task B, Validation exercise.* 1984.
- Griffiths, J.F. *Applied climatology, an introduction.* Oxford University Press, 1976.

- Griggs, E.I. and Courville, G.E. *Changes in building heating and cooling requirements due to a reduction in the roof's solar absorptance*. Proceedings of the ASHRAE/DOE/BTECC Conference on the thermal performance of the exterior envelopes of buildings III, Florida, 1985.
- Hay, H.R. and Yellott, J.I., *International aspects of air conditioning with movable insulation*. Solar Energy, 12, 1969.
- Hopkinson, R.G. *Glare from daylighting in buildings*. Applied Ergonomics, Vol. 34 1972.
- Hopkinson, R.G., Petherbridge, P. and Longmore, J. *Daylighting*. Heinmann, 1966.
- Hopkins, V., Gross, G. and Ellifritt, D. *Comparing the thermal performances of buildings of high and low masses*. ASHRAE conference, Philadelphia, 1979.
- Humphreys, M.A. *Field studies of thermal comfort compared and applied. Proceedings of the symposium on physiological requirements of the microclimate*. Prague, Czechoslovakia, 1975.
- Iqbal, M. *An introduction to solar radiation*. Academic Press, New York, 1983.
- Iranian Meteorological Organisation, *Tables of the averaged monthly climatic variables*.
- Jaeger, s. and Arumi, F. *A comparison of thermal requirements of buildings*. Energy and Buildings, Vol.1, 1977.
- Kammerud, R. et al *Ventilation cooling of residential buildings*. ASHRAE Transactions, Vol. 90, Part 1B, 1984.
- Keighley, E.C. *Visual requirements and reduced fenestration in office buildings, a study of multiple apertures and window area*. Building Science, Vol.8 1973.
- Keighley, E.C. *Visual requirements and reduced fenestration in office buildings - a study of window shape*. Building Science, Vol.8 1973.
- Kinniburgh, W., *Bitumen coverings for flat roofs*. Building Research establishment, Oversease building notes, No. 180, June 1987.
- Koenigsberger, O.H. et al *Manual of tropical housing and building, Climatic design*. Longman, 1973.
- Kolokotroni, M. and Young, A.N. *Guidelines for bioclimatic housing design in Greece*. Building and Environment, Vol.25, No.4, 1990.

- Kostiuk, L.W. and Dale, J.D. *Energy characteristics of a residential masonry structure*. ASHRAE Transactions, Vol. 93, Part 1, 1987.
- Leckner, B. *The spectral distribution of solar radiation at the earth's surface - Elements of a model*. Solar Energy, Vol. 20, No. 2, 1978.
- Lewis, D., Michal, C. and Pietz, P. *Design of residential building utilising natural thermal storage*. Division of buildings and community systems, U.S Department of Energy, June 1979.
- Littler, J.G.F. *Overview of some available models for passive solar design*. Computer Aided Design, Vol. 14, No. 1, 1982.
- Littler, J.G.F. *Review of some promising simulation models for passive solar design*. Sun at Work in Britain, Vol. 16, 1983.
- McIntyre, D.A. *Indoor climate*. Applied Science Publishers, 1980.
- McKenna, G.T. *The low energy window. Its impact on the interior visual environment*. Proceedings of windows in building design and maintenance. Goteborg, Sweden. 13-15 June 1984.
- McNall, P.E., Ryan, P., Jaax, J. *Seasonal variations for college - aged persons in the Middle West*. ASHRAE Transactions, Vol.74, 1968.
- McQuiston, F.C., Parker, J.D. *Heating, ventilating and air - conditioning, Analysis and design*. John Wiley & Sons, 1988.
- Markus, T.A. *The function of windows: A reappraisal*. Building Science Vol.2 1967.
- Markus, T.A., Morris, E.N. *Buildings, climate and energy*. Pitman, 1980.
- Mukhtar, Y.A. *An investigation into the thermal performance of roofs in hot dry climates*. Ph.D. thesis, University of Newcastle upon Tyne, 1976.
- Murphy, W.E. *The influence of the thermal capacity of a building on its energy consumption*. Proceedings of the 2nd international CIB symposium on energy conservation in the built environment. Copenhagen, 1979.
- Nayak, J.K. et al, *The relative performance of different approaches to the passive cooling of roofs*. Building and Environment, Vol. 17, No. 2, 1982.
- Ne'eman, E. and Hopkinson, R.G. *Critical minimum acceptable window size: a study of window design and provision of a view*. Lighting Research and Technology. Vol.2 1970.
- Ne'eman, E. and Shrifteilig, D. *Daylighting of buildings in a hot climate*. Energy and Buildings, Vol.4, 1982.

- Nieuwolt, S. *Tropical climatology, an introduction to the climates of the low latitudes*. John Wiley and Sons, 1977.
- Olgyay, A. and Olgyay, V. *Solar control and shading devices*. Princeton University Press, 1957.
- Olgyay, V. *Design with climate*. Princeton University Press, 1963.
- Page, J.K. *Application of building climatology to the problems of housing and building for human settlements*. Technical note No. 150, World Meteorological Organisation, WMO - No. 441, 1976.
- Paltridge, G.W. and Proctor, D. *Monthly mean solar radiation statistics for Australia*. Solar Energy, Vol. 18, No. 3, 1976.
- Parmelee, G.V. *Irradiation of horizontal and vertical surfaces by diffuse solar radiation from cloudless skies*. ASHVE Transactions, Vol.60, 1954.
- Property Service Agency (PSA), *Technical guide to flat roofing*. Department of the Environment. U.K., March 1987.
- Riazi, J. *Climate and comfort*. Ministry of Housing and Urban Design, Centre for Research on Housing and Building, Tehran, 1977. (in Farsi)
- Richards, S.J. *Solar charts for the design of sunlight and shade for buildings in South Africa*. South African Architectural Record, Vol. 36, No 11, 1978.
- Robinson, N.(Ed.) *Solar Radiation* Elsevier Publishing Company, 1966.
- Robinson, P. and Littler, J. *Methodology of window thermal performance assessment techniques in the US and the UK*. Department of Energy, UK, 1989.
- Rodgers, G.G., Souster, C.G. and Page, J.K. *Development of an interactive computer program SUNI*. Rep. IRN BS28, University of Sheffield, 1978.
- Rohles, F.H., Nevins, R.G. *The nature of thermal comfort for sedentary man*. ASHRAE Transactions, Vol.77, Part 1, 1971.
- Rohles, F.H., Nevins, R.G. *Thermal comfort: New directions and standards*. Aerospace Med. 44(7), 1973.
- Rossiter, W.J. and Mathey, R.G., *Effect of insulation on the surface temperature of roof membranes*. Centre for Building Technology, Institute for Applied Technology, National Bureau of Standards, U.S. Department of Commerce, February 1976.
- Rudoy, W. and Dougall, R.S. *Effect of the thermal mass on heating and cooling load in residences*. ASHRAE Conference, Philadelphia, 1979.

- Saini, B.S. *Building in hot dry climates*. Jhon Wiley and Sons, 1980.
- Shaviv, E. *Climate and building design - tradition, research and design tools*. Energy and Buildings, Vol.7 1984.
- Sodagar, B. and Warren, B.F. *The effect of mass on comfort and energy requirements in hot dry climates*. Proceedings of the XIth CIB International Congress on the Quality for Building Users Throughout the World, User Comfort, Paris, June 1989.
- Sodagar, B. and Warren, B.F. *Window design in hot dry climates*. Proceedings of CIB International Symposium on Energy, Moisture and Climate in Buildings, Rotterdam, September 1990.
- Spooner, D.C. *Thermal capacity*. Building, Vol.234, 12 May 1978.
- Sprague, C.H. , McNall, P.E. *The effect of fluctuating temperature and relative humidity on the thermal sensation of sedentary subjects*. ASHRAE Transactions, Vol.76, Part 1, 1970.
- Tavassoli, M. *Urban structure and architecture in the hot arid zone of Iran*. University of Tehran, 1979. (in Farsi)
- Tavassoli, M. *Windows in building design and maintenance in the hot dry climate*. Proceedings of ; Windows in building design and maintenance. Goteborg, Sweden, 13-15 june 1984.
- Trewartha, G.T. and Horn, L.H. *An introduction to climate*. McGraw-Hill Book Company, 1980.
- Udagawa, M. and Ishida, K. *Effect of insulation and heat capacity on the thermal performance of residential houses*. Proceedings of the CLIMA 2000, world congress on heating, ventilating and air - conditioning. Copenhagen, August 1985.
- United Nations Centre For Human settlements (Habitat), *Case studies on measures for energy-efficient shelter and infrastructure*. Narobi, 1986.
- van Hardenberg, J.G. *Considerations of houses adapted to local climate. A case study of Iranian houses in Yazd and Esfahan*. Energy and Buildings, Vol.4, 1982.
- van Straaten, J.F. *Roof insulation*. South African Architectural Record, February 1964.
- Watt, J.R. *Evaporative air conditioning handbook*. Chapman & Hall, 1980.
- Wilcox, B. etal *The effects of thermal mass in exterior walls on heating and cooling loads in commercial buildings*. Proceedings of the ASHRAE/DOE/BTECC conference on the thermal performance of the exterior envelopes of buildings III. December 1985, Florida.

Willoughby, J.F., *An experimental investigation of the thermal response of a building cell*. MPhil thesis, University of Nottingham, 1972.

Wiltshire, T.J. and Wright, A.J. *The evaluation of the simulation models ESP, HTB2 and SERI-RES for the UK Passive Solar Programme*. A report prepared for the Energy Technology Support Unit of the Department of Energy. Building Science Section, School of Architecture, University of Newcastle upon Tyne, August 1987.

Wiltshire, T.J. and Wright, A.J. *The documentation and evaluation of building simulation models*. Building Environmental Performance Analysis Club (BEPAC), Technical note 89/2, November 1989.