

# Sensorless Position Control of a PMSM for Steer-by-Wire Applications

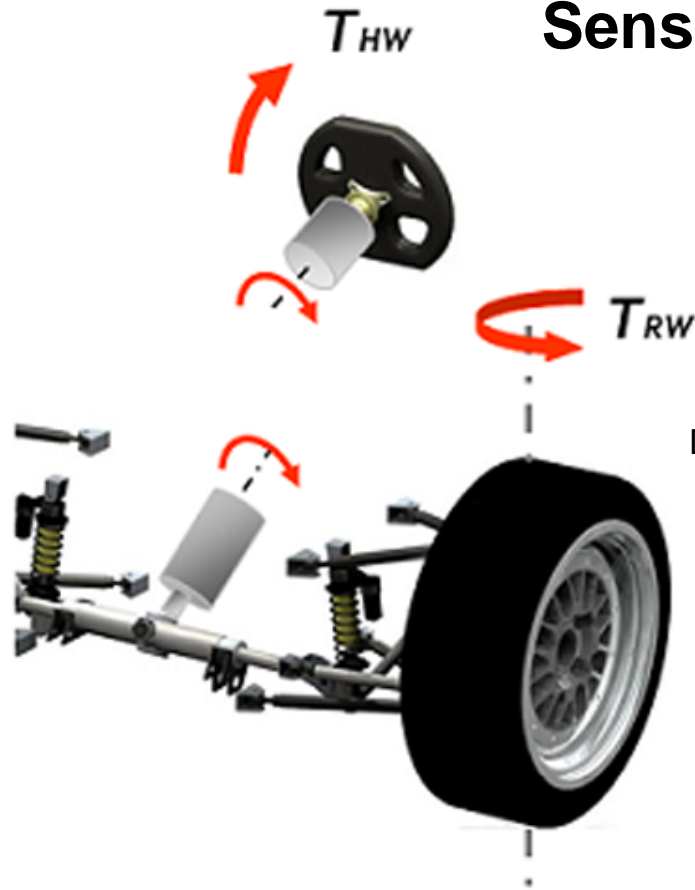

CoDIT 2016

Department of Industrial Electric Power Conversion  
Faculty of Engineering, University of Malta

Kris Scicluna  
Prof. Ing. Cyril Spiteri Staines  
Dr. Reiko Raute



UNIVERSITY OF MALTA  
L-Università ta' Malta





# Contents

---

- Introduction
- Literature Review
- Theory
- Simulation Results
- Conclusions



# Introduction : Steer-by-Wire (SbW) System



Figure 1 – Differences between *conventional mechanical steering arrangement (left)* and *SbW System (right)*

- In SbW the kinematic chain in the steering arrangement is broken down.
- Two electric motors are introduced to provide torque feedback at the handwheel and actuation at the steered wheel side.
- The dynamic response of the SbW system must be comparable in tracking the handwheel changes to the road wheel / steered wheel side.



# Introduction : Sensorless Control in SbW

---

- The position measurement of the handwheel and steered wheel are of a critical safety nature in SbW.
- Researchers/developers introduce redundant additional position sensors as backup to cater for sensor failure.
- In this research it is proposed to use sensorless control observers to validate encoder measurements instead of redundant sensors.
- The electric drive can be operated in a sensorless closed-loop under fault conditions with a comparable dynamic response.



## Literature Review : SbW Advantages

---

- The absence of the steering column simplifies interior car design and allows car designers more creative freedom in placing the handwheel.
- The absence of the steering shaft and column allows for better utilization of the engine compartment as the volume required by the steering mechanism is reduced.
- The steer-by-wire system dynamics can be easily adjusted to optimize steering response and driver comfort.
- The risk of hydraulic fluid leaking associated with traditional power steering is completely eliminated .



## Literature Review : SbW Disadvantages

---

- Complexity in generating an authentic force feedback at the handwheel which emulates that of a mechanically coupled system and which has the same physiological/physical effects on the driver.
- For widespread commercial implementation in production cars the system must have the same dynamic performance or preferably outperform conventional mechanically coupled systems .
- Steer-by-wire is the most complex of the by-wire systems due to the a large number of electrical/electronic sub-systems required.



# Literature Review : Sensorless Control

- Sensorless control is required for :
  - (a) Open-loop observation of position/speed measurements
  - (b) Closed-loop control under fault conditions

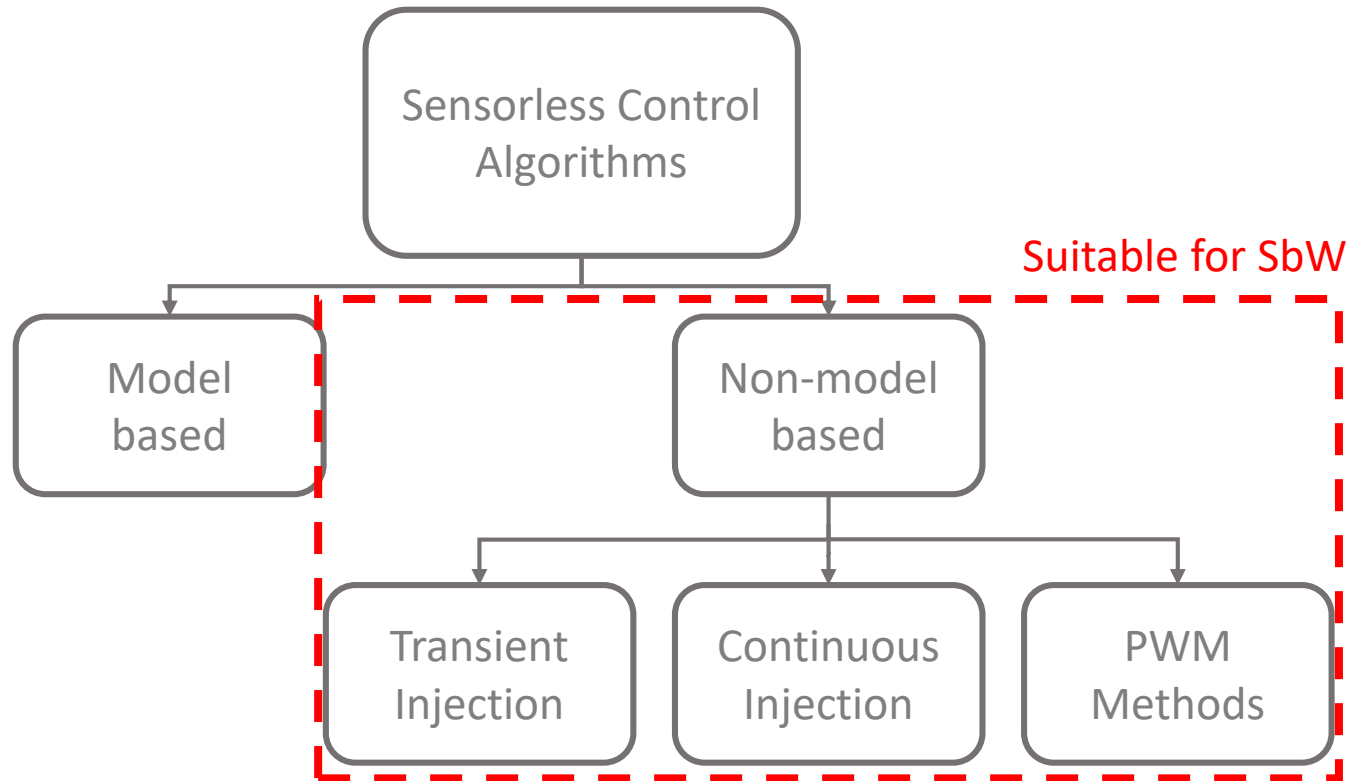

Figure 2 – Sensorless Control Algorithms Review



# Theory: Permanent Magnet Synchronous (PMSM) Machine Modelling

- The PMSM is ideal for the SbW application for a number of reasons including:
  - (a) Higher efficiency and higher power density.
  - (b) Better heat dissipation characteristics than brushed DC motors and induction motors.
  - (c) No maintenance of commutator and brushes required.
  - (d) Higher maximum speeds possible than similarly power rated brushed DC motors.
  
- PMSM was modelled expressed in the dq frame:

$$v_{s_d} = R i_{s_d} + L_d \frac{d i_{s_d}}{dt} - \omega_r L_q i_q$$

$$v_{s_q} = R i_{s_q} + \omega_r L_d i_{s_d} + \omega_r \Psi_{r_d} + L_q \frac{d i_{s_q}}{dt}$$

$v_s$  Stator Voltage

$R$  Stator Resistance

$i_s$  Stator Current

$L$  Stator Inductance

$\omega_r$  Electrical Frequency





# Theory: Rotor Flux Orientated Vector Control

- Cascaded control loops for position, speed and current.
- Proportional (P) Position Control
- Proportional Integral (PI) Speed Control
- Proportional Integral (PI) Current Control

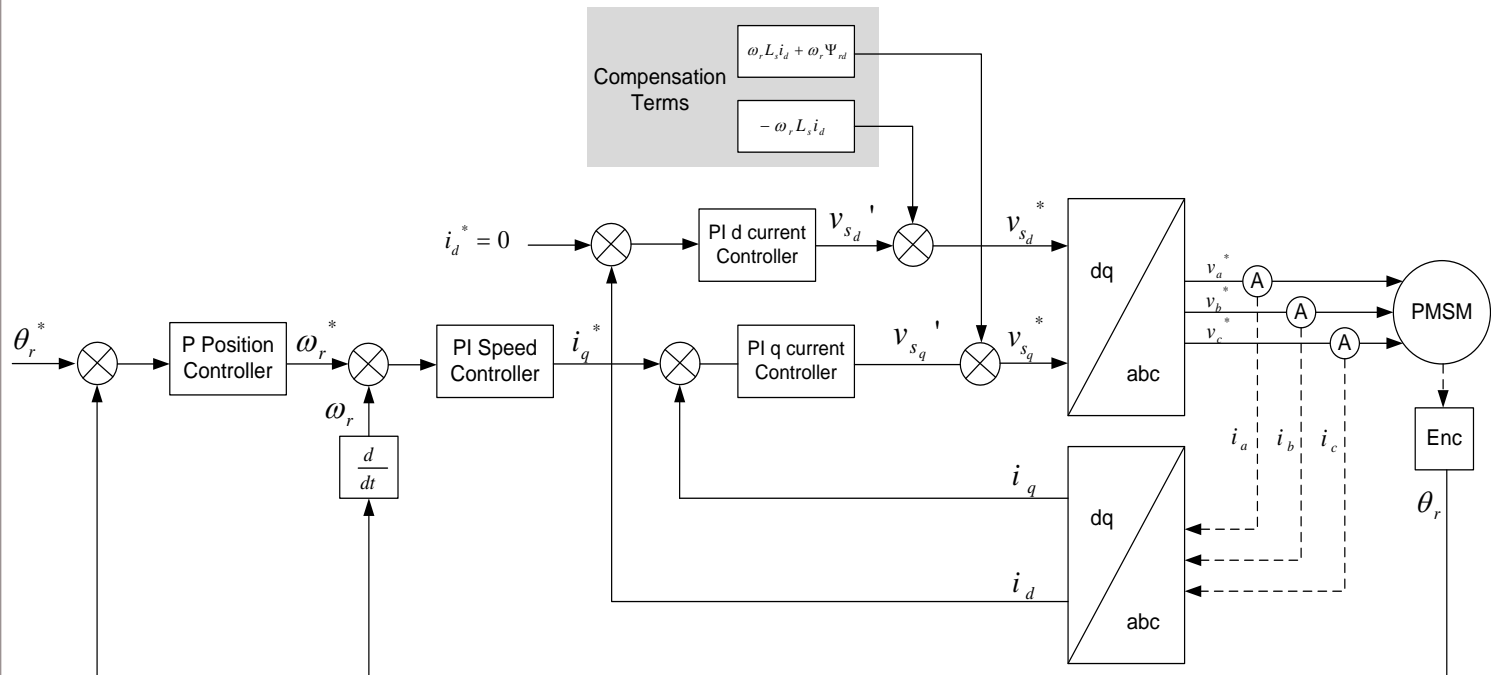

Figure 3 – Rotor Flux Orientated Vector Control Diagram



# Theory: Current Controller Design

- The transfer functions for the dq current controllers are obtained from the dynamic stator equations.
- When the cross-coupling terms are eliminated equations on which Laplace Transforms can be easily applied result:

$$v_{s_d} = R i_{s_d} + L_d \frac{d i_{s_d}}{dt}$$

$$v_{s_q} = R i_{s_q} + L_q \frac{d i_{s_q}}{dt}$$

- The PI d/q controllers were set at a bandwidth of **120 Hz damping ratio 0.84** during sensorless operation.
- The bandwidth can be increased to **327 Hz damping ratio 0.707** during sensed operation.

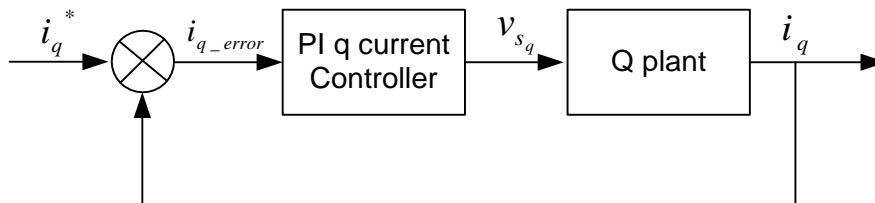

Figure 4 – Closed-loop isq current control



## Theory: Speed Controller Design

- The speed controller is tuned using the following transfer function:

$$\frac{\omega(s)}{I_q(s)} = \frac{K_t}{sJ + B}$$

- The PI speed controller was set at a bandwidth of **13 Hz damping ratio 0.707** during sensorless operation.
- The bandwidth can be increased to **65.41 Hz damping ratio 0.707** during sensed operation.

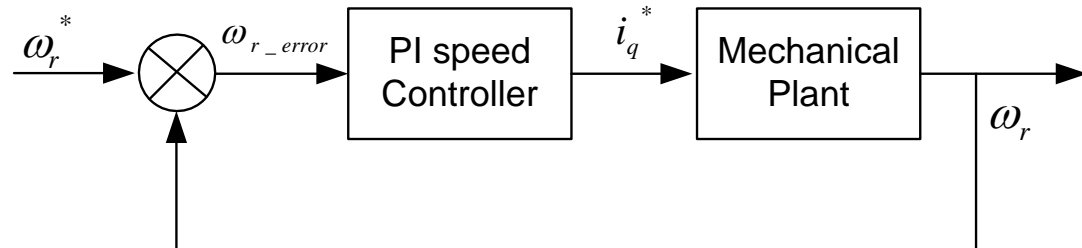

Figure 5 – Closed-loop speed control



## Theory: Position Controller Design

- The position controller is tuned using the following transfer function:

$$\frac{\theta_r(s)}{\omega_r(s)} = \frac{1}{s}$$

- The PI position controller was set at a bandwidth of **1.6 Hz damping ratio 1** during sensorless operation.
- The bandwidth can be increased to **13.08 Hz damping ratio 1** during sensed operation.

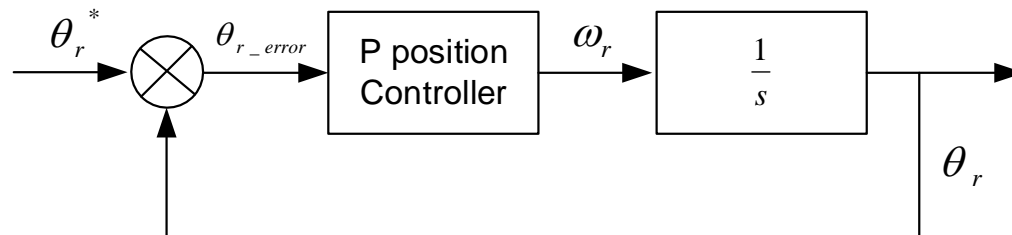

Figure 6 – Closed-loop position control



# Theory: High Frequency Injection Saliency Tracking

- High Frequency Injection Saliency Tracking is done by injecting a continuous signal on the fundamental stator voltages in the form of:

$$v_{i\alpha\beta} = \begin{bmatrix} v_{i\alpha} \\ v_{i\beta} \end{bmatrix} = \begin{bmatrix} V_i \cos(\omega_i t) \\ V_i \sin(\omega_i t) \end{bmatrix}$$

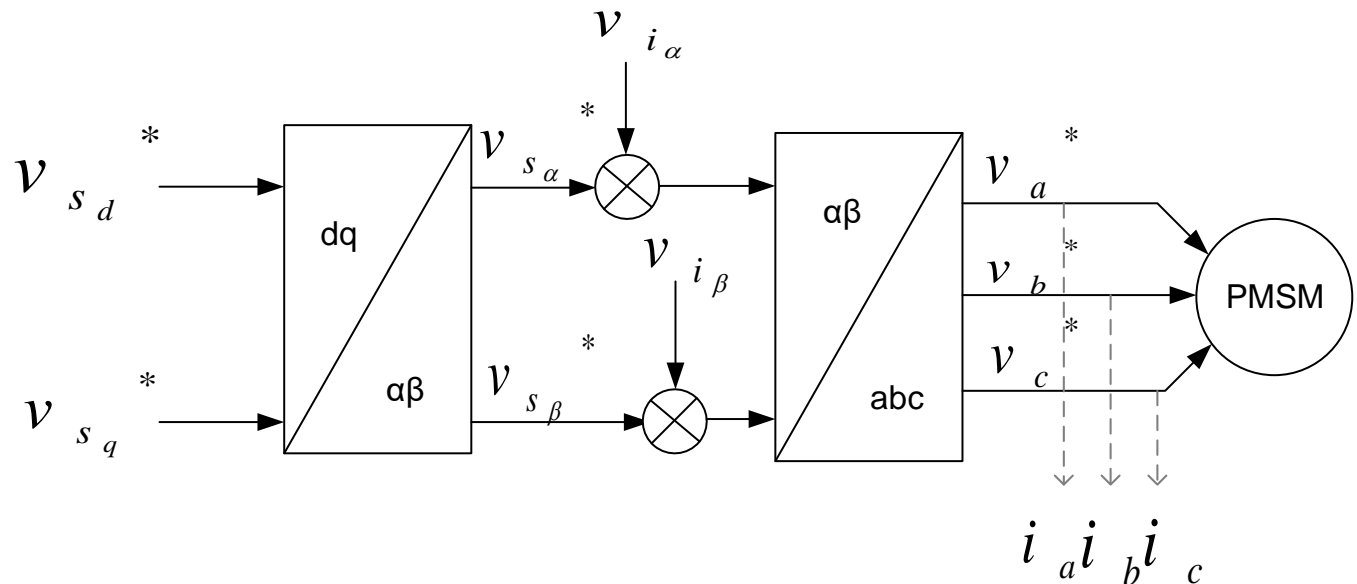

Figure 7 – High Frequency Injection of Stator Voltages



# Theory: High Frequency Injection Saliency Tracking

- The isolated high frequency components in the  $\alpha\beta$  frame are used for position/speed purposes with a PLL based observer as shown in Figure 12.

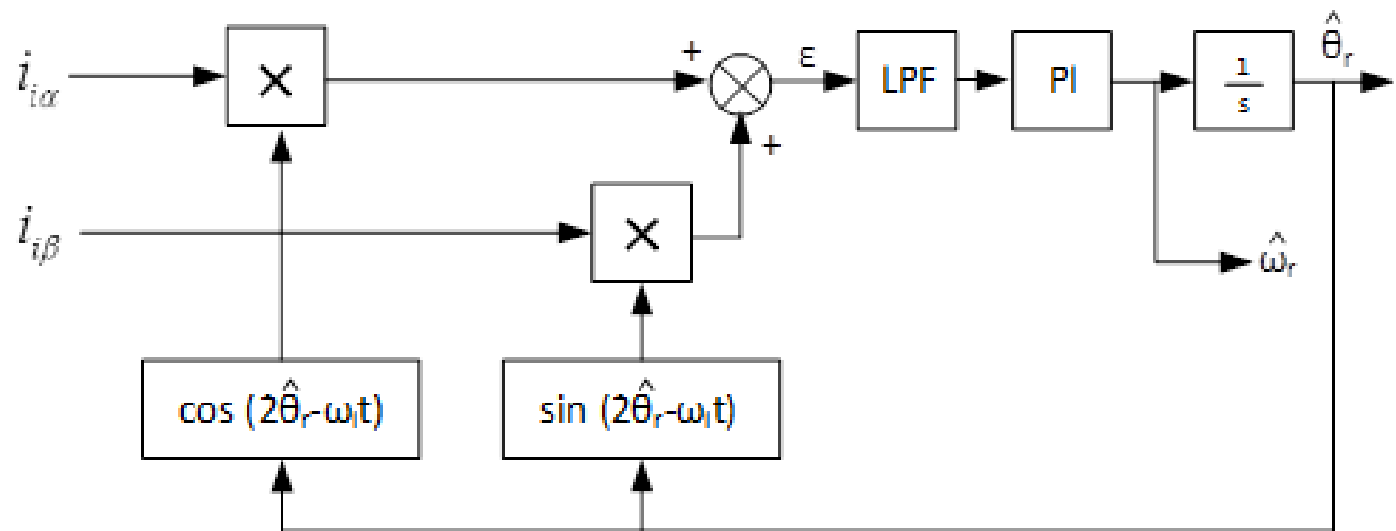

Figure 8 – PLL rotor position/speed estimator with heterodyning



## Theory: Linearized PLL Observer Tuning

- In order to tune the gain values of the PI controller in the loop using frequency domain tools such as the SISO tool in MATLAB a linear transfer function is required. The error term in the PLL loop is:

$$\varepsilon = I_{i0} \sin(2(\omega_i t - \widehat{\theta}_r)) + I_{i1} \sin(2(\theta_r - \widehat{\theta}_r))$$

- If the error term  $\varepsilon$  is filtered through an appropriately designed low-pass filter:

$$\varepsilon_f \approx I_{i1} \sin(2(\theta_r - \widehat{\theta}_r))$$

- Assuming that the error between the actual and estimated rotor angles is small:

$$\varepsilon_f \approx I_{i1} (2(\theta_r - \widehat{\theta}_r))$$



# Theory: Linearized PLL Observer Tuning

- The difference between the actual and estimated rotor angles can be written as:

$$\theta_r - \hat{\theta}_r \approx \frac{\varepsilon_f}{2I_{i1}}$$

- This can be used to linearize the input part of the PLL loop such that a linear model of the approximated system is obtained as shown Figure 13.

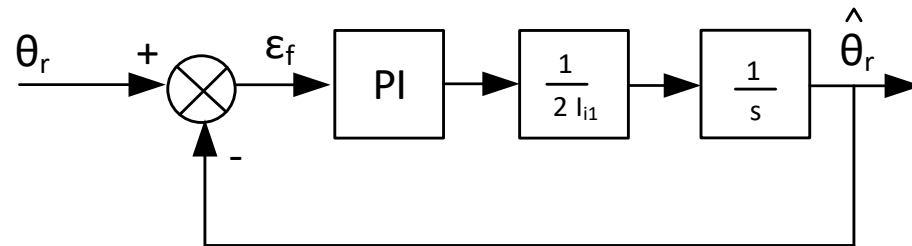

Figure 9 – Linearized PLL Estimation Loop

- For closed-loop sensorless operation in the steer-by-wire application the closed-loop bandwidth of the PLL loop was tuned at 54 Hz.





# Experimental Setup: SbW Rig Concept Diagram

- Driving Machine ( $T_d$ ) – Position Controlled
- Force Feedback/Reaction Machine ( $T_r$ ) – Current Controlled
- Steering Machine ( $T_s$ ) – Position Controlled
- Environment Machine ( $T_e$ ) – Current Controlled.

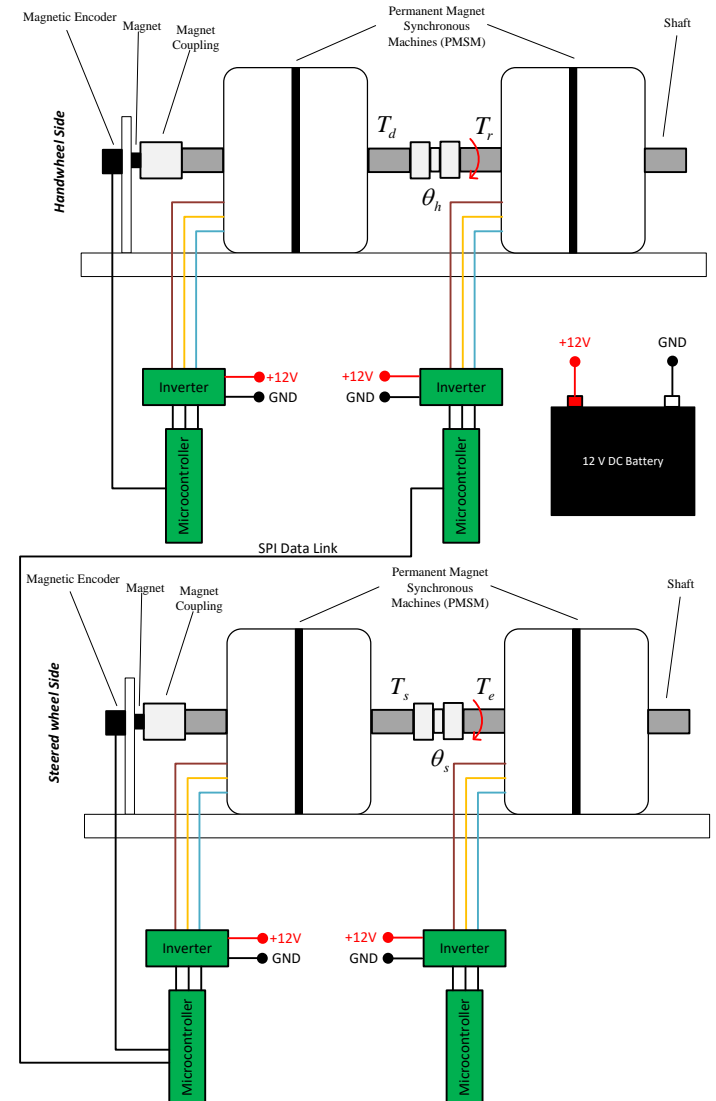

Figure 10 – SbW Concept Diagram



# Simulation Results: Sensorless Open-loop Position/Speed Observation

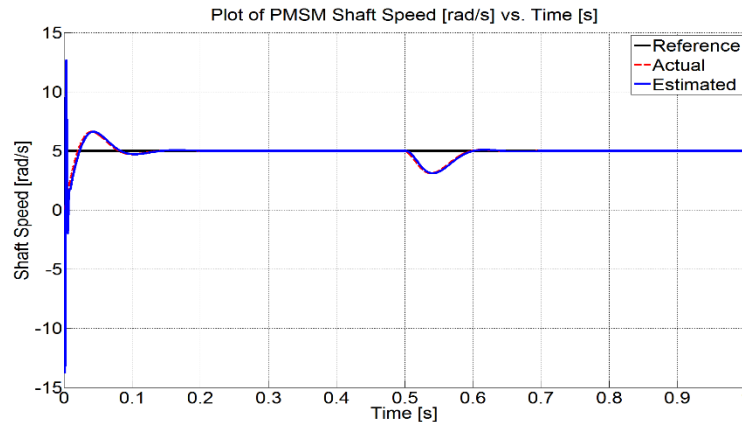

Figure 11 - Plot of Actual/Estimated PMSM Shaft Speed in open-loop mode with full load of 5 Nm applied at  $t=0.5$  s and HF injection at 2 kHz.

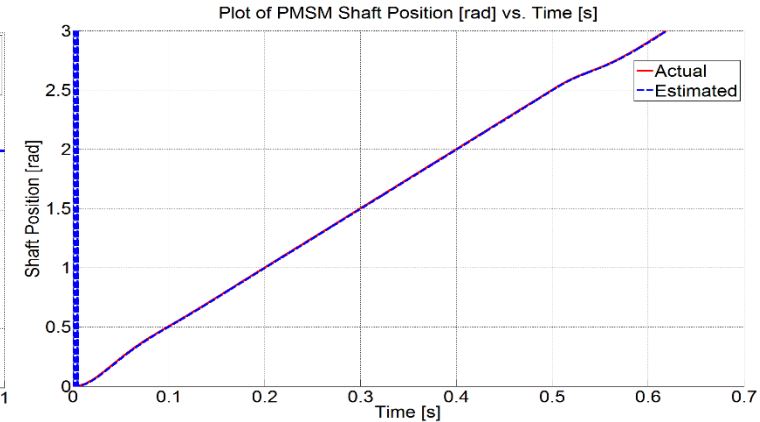

Figure 12 - Plot of Actual/Estimated PMSM Shaft Position in open-loop mode with full load of 5 Nm applied at  $t=0.5$  s and HF injection at 2 kHz.

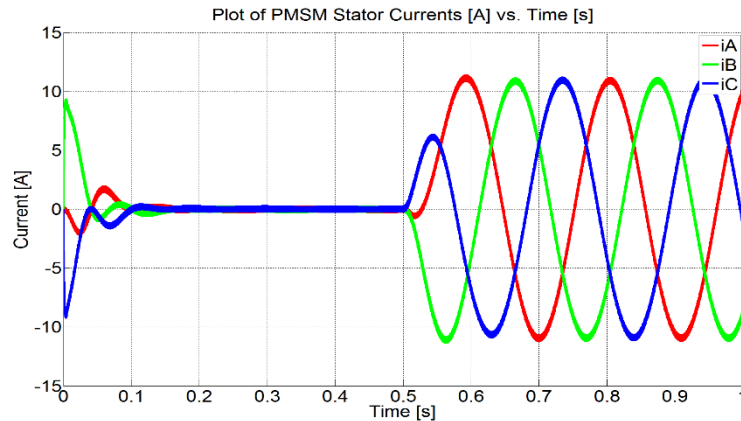

Figure 13 - Plot of PMSM Stator Currents in open-loop mode with full load of 5 Nm applied at  $t=0.5$  s and HF injection at 2 kHz.



# Simulation Results: Sensorless Closed-loop Position/Speed Control

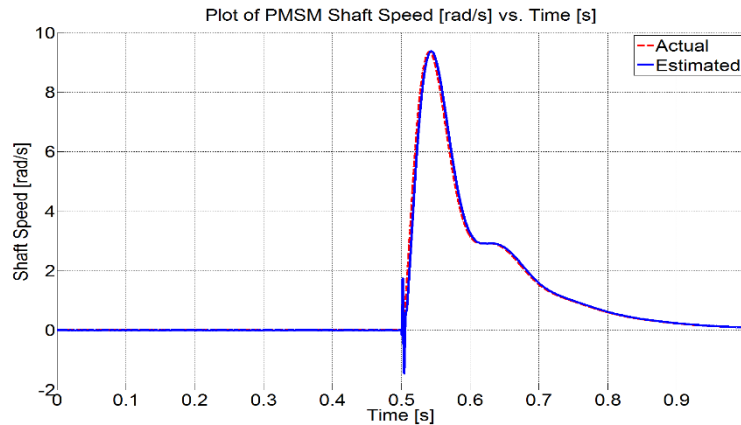

Figure 14 - Plot of Actual/Estimated PMSM Shaft Speed with full load of 5 Nm and HF injection at 2 kHz, sensorless control operation with a change in position reference of 1 rad at  $t=0.5$  s.

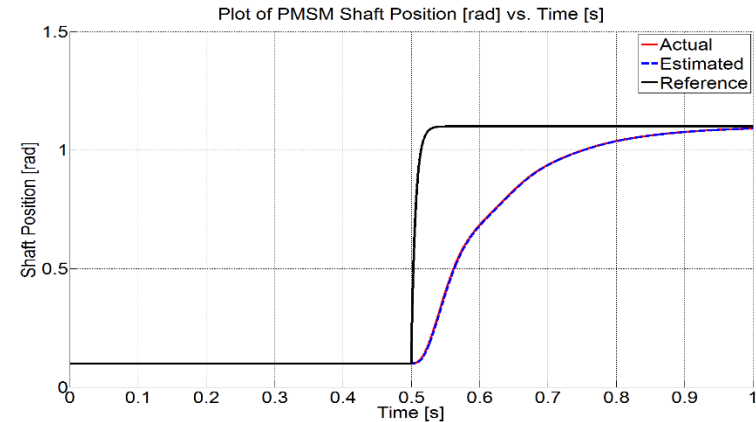

Figure 15 - Plot of Actual/Estimated PMSM Shaft Position with full load of 5 Nm and HF injection at 2 kHz, sensorless control operation with a change in position reference of 1 rad at  $t=0.5$  s.

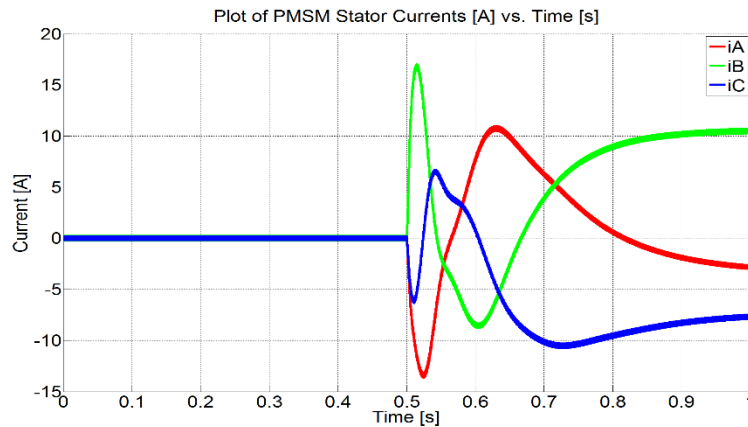

Figure 16 - Plot of PMSM Stator Currents with full load of 5 and HF injection at 2 kHz, sensorless control operation with a change in position reference of 1 rad at  $t=0.5$  s.

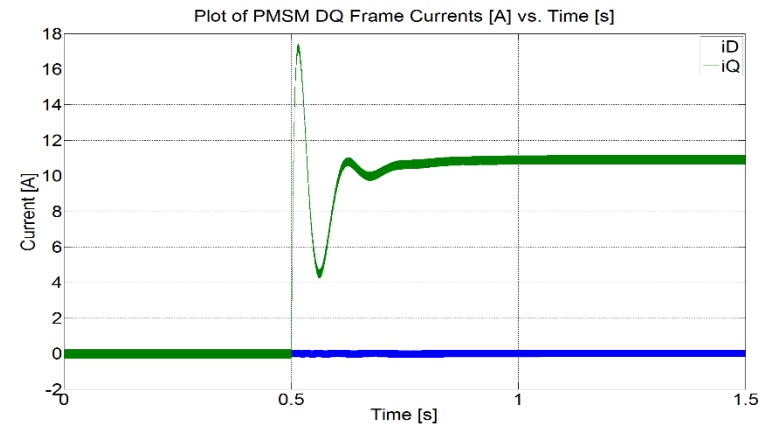

Figure 17 - Plot of PMSM Stator DQ Frame Currents with full load of 5 Nm and HF injection at 2 kHz, sensorless control operation with a change in position reference of 1 rad at  $t=0.5$  s.



# Conclusions

---

- **Open-loop position/speed estimation** was shown with minimum error. This shows that the observer can eliminate backup encoder measurements reducing cost and mechanical design complexity.
- **Closed-loop sensorless control** with a slightly reduced dynamic response was shown with a stable machine response and correct sensorless observation under different position/speed conditions.



# Conclusions

---

- Simulation of the complete four motor steer-by-wire system with High Frequency Injection saliency tracking.
- Operation of the experimental rig in a sensed mode with encoders such that the position of the shaft at the handwheel side is identical to that on the steered wheel side.
- Implementation of the High Frequency Injection saliency tracking sensorless method on the experimental steer-by-wire setup.
- Simulation and Implementation of other sensorless methods which are suitable for sensorless control at low/zero speed operation.



# End of Presentation

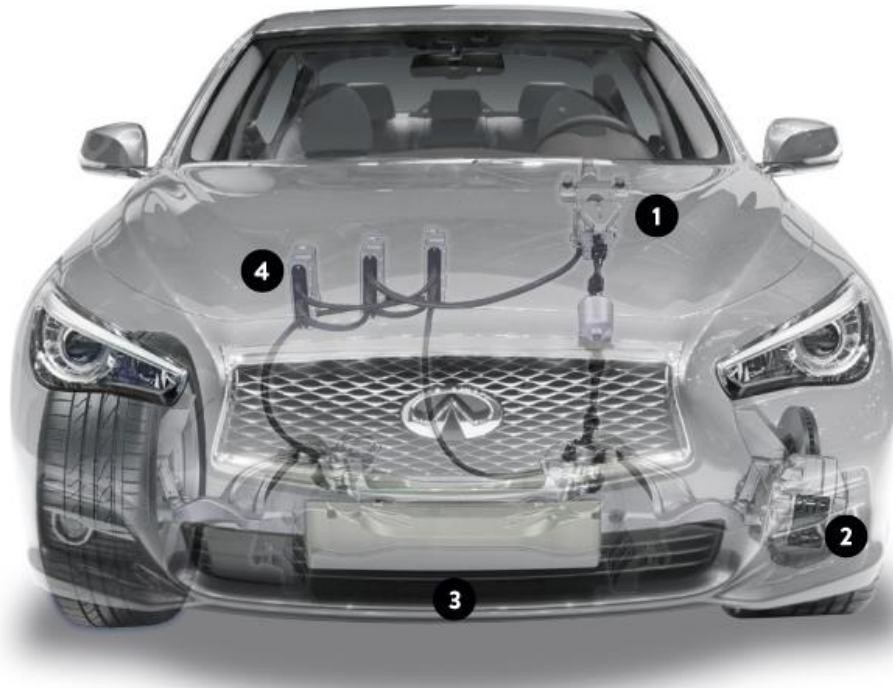

Figure 18 – Infiniti Q50 2014, production Car released with Direct Adaptive Steering (primary steer-by-wire with backup mechanical link).

**Kris Scicluna**  
Part-time Research Student  
IEPC, University of Malta

**Prof. Ing. Cyril Spiteri Staines**  
Associate Professor  
IEPC, University of Malta

**Dr. Reiko Raute**  
Lecturer  
IEPC, University of Malta