



Acta Horticulturae
Number 474

**Proceedings of the
Third International Symposium**

**on
Olive Growing**

Editors

I.T. Metzidakis

D.G. Voyiatzis



ISHS

Volume 1

Editor

Ioannis Metzidakis

Organising Committee

Dr. I. Metzidakis, (Chairman) NAGREF,
Subt. Plants and Olive Tree Institute, Greece
Prof. D. Voyiatzis, Aristotles University
of Thessaloniki, Greece
Mrs M. Mathioudi, NAGREF,
Athens, Greece
Mr. S. Panayiotou, Ministry of Agriculture,
Athens, Greece
Mrs E. Papakosta, NAGREF,
Athens, Greece

Secretariat

V. Selianakis, E. Pateraki, N. Detorakis
and K. Kambaki,
NAGREF, Subtropical Plants

**International Olive Working
Group Executive Committee**

Prof. D. Voyiatzis, Greece
(Chairman, 1993-1997)
Prof. S. Lavee, Israel
Dr. J. Caballero, Spain
Dr. C. Vitagliano, Italy
Dr. G. Martín, USA

All papers have been reviewed by two experts

ISBN 90 6605 871 4, Acta Horticulturae n° 474

Price for non-members of ISHS for Volume 1 and 2: €123,-

Published by ISHS, April, 1999

Executive Director of ISHS: Ir. J. Van Assche
Kardinaal Mercierlaan 92, 3001 Leuven, Belgium

Printed by Drukkerij P.J. Jansen BV, Aalmarkt 1-3, 2311 EC Leiden, The Netherlands

© 1999 by the International Society for Horticultural Science (ISHS). All rights reserved. No part of this book may be reproduced and/or published in any form or by any means, electronic or mechanical, including photocopying, microfilm and recording, or by any information storage and retrieval system, without written permission from the publishers.

Photographs on the front cover:

1. Tillage in new olive orchard
2. Olive tree cv Koroneiki in full production
3. Details of fruiting of cv Mastoides
4. Globe-shaped trees undergoing cutting back in 1 m height from ground level
5. Heavy pruned irrigated trees one year after
6. Details of fruiting of cv Koroneiki

Co-Editor

D. Voyiatzis

Editorial Board

Dr. E. Barone, University of Reggio,
Calabria, Italy
Dr. Y. Ben-Tal, ARO,
Volcani Center – Bet Dagan – Israel
Dr. J. Caballero, C.I.F.A.
" Alameda del obispo" – Cordoba, Spain
Dr. L. Ferguson,
University of California, Davis
Prof. A. Kyritsakis,
Technological Institute of Thessaloniki, Greece
Prof. S. Lavee, Volcani Center
Hebrew University - Bet Dagan – Israel
Dr. I. Metzidakis NAGREF
Subtropical Plants and Olive Tree Institute, and
Olive Tree Institute Greece
Dr. H. Rapoport,
University of Cordoba – Spain
Prof. A. Tombesi,
University of Perugia – Italy
Dr. C. Vitagliano,
University of Pisa, Italy
Prof. D. Voyiatzis,
Aristotles University of Thessaloniki, Greece

EFFECT OF TREE SIZE AND VARIETY ON OLIVE HARVESTING WITH AN IMPACT SHAKER

A.B. Dias, J.O. Peça and
A.C. Pinheiro,
Área Departamental
Ciências Agrárias da
Universidade de Évora

S. Costa
Engineering Student of
Universidade de Évora

A. Almeida
Escola Superior Agrária de
Bragança

L. Santos
Departamento Olivicultura
da Estação Fruticultura
Vieira Natividade

Reynolds de Souza, D.
Reynolds and Oliveira Ld^a
J. Lopes, Direcção Regional
de Agricultura de Trás-os-
Montes

Keywords: Olive harvesting, vibration

Abstract

Tests were carried out in Alentejo (Southern Portugal), with the objective of studying the influence of tree size and varieties in olive harvesting by vibration.

A shaker manufactured in Portugal, mounted on a front loader of a four wheel drive tractor was used in the tests. The shaker requires a minimum of 30 kW and vibrates either the trunk, or the main branches.

The results will be stated in terms of the percentage of olives harvested within the total yield, work rate and time of vibration per tree.

1. Introduction

Manual olive harvesting represents more than 50% of the total production costs. Large olive growers have made the natural step towards mechanization, and tree shakers are nowadays a common equipment for olive harvesting. Multidirectional shakers are the solution adapted by most of the farmers in Portugal. In 1990, the portuguese company R&O, designed and manufactured a tree shaker using the impact principle instead of the multidirectional principle. The company was awarded by the American Society of Agricultural Engineers in 1992. The aim of this poster is to show data collected during a first evaluation of this impact shaker performing olive harvesting in three different tree sizes.

2. Materials and methods

2.1. The shaker

Figure 1 shows a side view of the shaker. Placed in a casing (2), two eccentric masses are turned by a hydraulic motor (1), providing a linear sinusoidal driving force which acts at a metallic bumper (8), guided by a telescopic tube (3), producing an impact on the clamp/trunk (4) thus vibrating the tree. The impact shaker is mounted on a front loader (figure 2), in a four wheel drive tractor of 50 kW. This shaker is able of vibrating either the trunk or the main branches.

2.2. Olive orchards and field operation

Field trials took place in Moura which is one of the main olive production regions of Alentejo (Southern Portugal). Figure 3 shows the canopy projection of the olive orchard. The experiments were conducted as if we had three different orchards in the same field (figure 4). First the «Cordovil» variety was harvested, then the «Galega 1» and finally the «Galega 2» variety.

Olives were collected on a canvas held by 4 labourers. Meanwhile 4 other labourers were laying down canvas under the trees in the next row (Fig. 5).

3. Results

Results were presented in Table 1, Figure 6, Figure 7, Figure 8 and Figure 9.

4. Conclusions

From figure 8, in the «Galega» variety the mass of olives harvested as a percentage of total mass is between 70 and 80% during 20 and 10 seconds of vibration respectively. These values are similar to those stated by Cini, Antognozi and Tombesi for multidirectional shakers, and reflect situations where most of the trees are trunk shaken.

«Cordovil» variety, being a larger tree, required 45 seconds of effective vibration time (EVT). Above all it was necessary to vibrate the main branches rather than just vibrating the trunk to obtain a similar degree of 77% of mass harvested. This explains the average total vibration time per tree (TVT) of 98 seconds. As a result the work rate found in the «Cordovil» variety was lower and, as expected, the smaller trees showed a faster work rate. However, more studies about the ability of this shaker to the portuguese conditions are required.

Acknowledgements

The authors wish to thank the olive grower for his collaboration and the portuguese research programme PAMAF (Programa de Apoio à Modernização Agrícola e Florestal), with the project PAMAF 2072 for the financial support.

References

- Cini, E. and Cioni, A. 1993. Un'operatrice per la raccolta meccanica delle olive, m&ma, n°7-8,
- Antognozi, E., Tombesi, A. and Palliotti, A. 1993. Influence of age, tree shape and cultivar on mechanical harvesting of olives
- Tombesi, A., Cartechini, A. and Proietti, P. 1993, Influence of the kind of vibration on olive mechanical harvesting

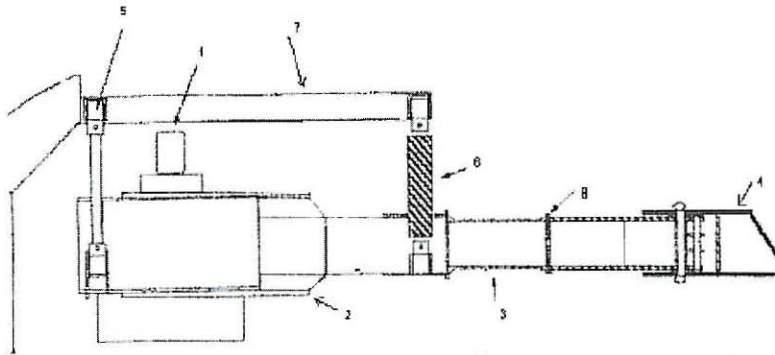

Figure 1. Side view of the shaker
 1 - Hydraulic motor; 2 - eccentric mass casing; 3 - telescopic tube; 4 - clamp; 5 - cynobloc suspension; 6 - helicoidal springs suspension; 7 - support frame; 8 - impact bumper



Figure 2. Shaker mounted on a tractor

Variety	Size of tree	Distance in the row	Distance between rows
"Cordovil"	Large	20 m	20 m
"Galega 1"	Medium	20 m	20 m
"Galega 2"	Small	10 m	20 m

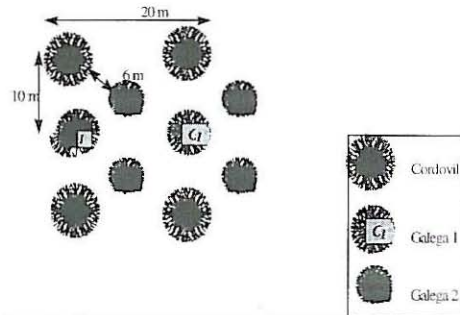

Figure 3. Canopy projection of the olive orchard



Figure 4. Partial view of olive orchard

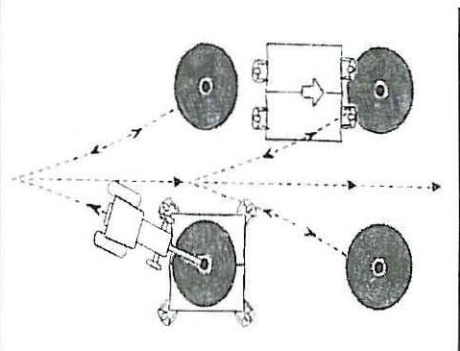

Figure 5. Layout of field operation

Table 1. Characteristics of the trees

Variety	Trunk diameter (m)	Crown diameter (m)	Crown height (m)	Tree height (m)	Total yield (kg)	W-Olives weight (g)	F-Detachment force (g)	F / W
Cordovil	0,52	4,92	2,89	4,13	26,7	4,01	431,2	107,5
Galega 1	0,24	4,43	2,68	3,83	6,4	2,31	311,3	134,8
Galega 2	0,15	2,87	2,08	3,42	3,3	2,31	311,3	134,8

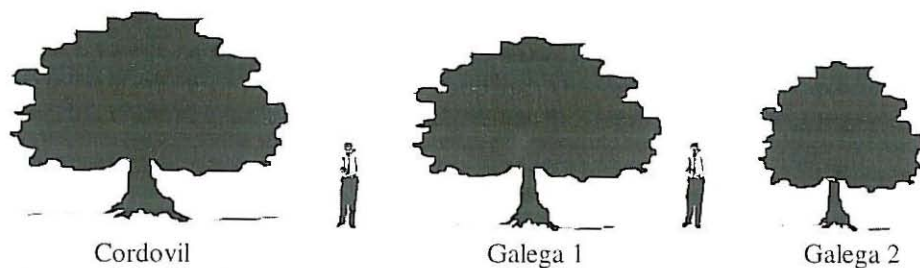
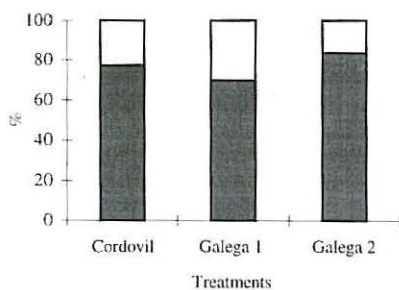
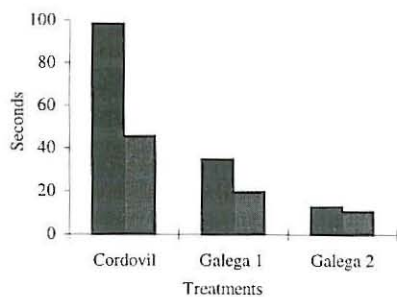

Figure 6. Layout of tree sizes



■ Total vibration time ■ Effective vibration time ■ Olives removed □ Olives not removed

Figure 7. Time of vibration per tree average Figure 8. Mass of olives harvested in % (of total yield (average of 60 trees)

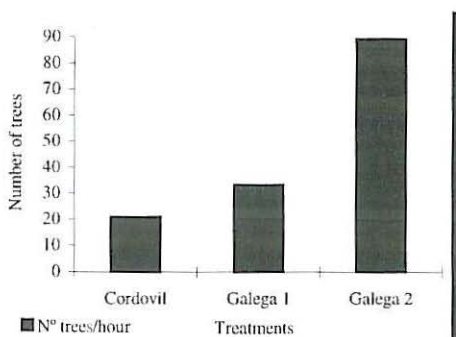

Figure 9. Work rates in trees per hour