

A new evaluation model for e-learning programs

URANCHIMEG TUDEV DAGVA¹, WOLFRAM HARDT²

Abstract

This paper deals with a measure theoretical model for evaluation of e-learning programs. Based on methods of general measure theory an evaluation model is developed which can be used for assessment of complex target structures in context of e-learning programs. With the presented rating function target structures can be evaluated by a scoring value which indicates how the targets in sense of a given logical target structure has been reached. A procedure is developed for the estimation of scoring values for target structures based on adapted assessment checklists.³

Keywords

e-learning, e-courses, evaluation, scoring, target structure, e-learning quality, assessment checklist, evaluation model, ELQ.

1 Introduction

Quality of e-learning programs is a very intensive and controversy discussed topic of recent time. Background is the worldwide challenge for the development of methods and tools for lifelong learning that becomes more and more realistic by the fast progress on all areas of e-tools and especially of Internet. In this context the call for adapted education standards, a corresponding quality evaluation and process management of e-learning tools becomes always louder. However no approach for evaluation of e-learning programs could reach a general acceptance until now. For a corresponding overview we refer to the report [1] of Swedish National Agency for Higher Education. This report contains an excellent survey on the European view on e-learning and quality assessment. A concise further overview on quality research in e-learning is given by [3]. For some additional or special aspects we refer to [5], [6], [7] and [9], for instance.

The quantitative models for assessment of e-learning quality considered usually are as a rule additive models. That means, depending on the considered aspects, which are measured based on a defined scale, a linear function containing corresponding weight factors is used like, e.g.,

$$Q = \sum_{i=1}^r \alpha_i x_i.$$

Here denote α_i , $\alpha_i > 0$, given weight factors for the obtained measure values x_i , $i = 1, \dots, r$, for the considered aspects. The advantage of this formula is, it is very easy. The disadvantage is, that the choice of proper weight factors is subjective. Moreover, positive evaluation values can be obtained even in such cases if the targets of certain quality aspects has been failed. A possible logical inner structure of target structures remains out of consideration.

In contrast to these linear approaches we develop here a measure theoretical model for the

¹Mongolian University of Science and Technology, Ulaanbaatar, Mongolia, uranchimeg@must.edu.mn.

²Chemnitz University of Technology, Chemnitz, Germany, wolfram.hardt@informatik.tu-chemnitz.de.

³This study has been supported by a grant of Schlumberger Foundation

assessment of a e-learning program. We consider an e-learning program whose quality is determined by k , $k \geq 1$, several aspects or characteristics M_1, \dots, M_k . We assume that the quality of the single aspects can be measured by means of a given scale where the corresponding observation variables are ordinal or metrical ordered variables. Our aim is to develop an evaluation model for e-learning programs whose quality is characterised as above by k several aspects M_1, \dots, M_k . For it we will construct a corresponding measure in sense of general measure theory. This requires in the context considered here two steps. First we will construct k corresponding efficiency measure spaces for description of quality of single aspects M_1, \dots, M_k . After that we will combine these spaces to a corresponding product space. This space will describe the considered aspect structure as a whole. The via the obtained product space defined product measure will be then our quality measure for evaluation of an e-learning program. For the implementation and application of our assessment approach the paper is rounded off by a procedure for the estimation of scoring values for target structures based on adapted assessment checklist.

The advantage of the model considered here in comparison with linear models is that by the multidimensional consideration via the product measure the logical structure of a target structure is evaluated as a whole.

2 The model

2.1 Measure spaces for the single aspects

For description of quality of a single aspect M_i , $i = 1, \dots, k$, we consider a measure space $(\Omega_i, \mathcal{A}_i, Q_i)$. A measure space consists of three objects Ω_i, \mathcal{A}_i and Q_i which can be defined here as follows:

- 1.) Let $\Omega_i = \{\omega_{i1}, \omega_{i2}\}$ be a two-element set - the set of *elementary targets*. In this sense the element ω_{i1} is standing for: the target in sense of aspect M_i has been reached (is reached), the element ω_{i2} is standing for: the target in sense of M_i has not been reached (is not reached). The set Ω_i is denoted as *target space* with respect to the aspect M_i .
- 2.) Let \mathcal{A}_i be the set of all subsets of Ω_i . Then we have

$$\mathcal{A}_i = \{\phi, A_{i1}, A_{i2}, \Omega_i\},$$

where A_{i1} and A_{i2} are defined by $A_{i1} = \{\omega_{i1}\}$ and $A_{i2} = \{\omega_{i2}\} = \overline{A_{i1}}$, for instance. The elements of set system \mathcal{A}_i can be interpreted as *target structures* as follows:

- A_{i1} - target in sense of aspect M_i has been reached,
- $\overline{A_{i1}}$ - target in sense of aspect M_i has been not reached,
- Ω_i - any target in sense of aspect M_i has been reached,
- ϕ - nothing has been reached.

The set \mathcal{A}_i is in sense of measure theory a σ -algebra. We denote the elements of \mathcal{A}_i as *target structures* and the set \mathcal{A}_i itself as *target algebra*. In this context we say: the target in sense of a target structure $A \in \mathcal{A}_i$ has been reached (is reached) if an $\omega \in A$ has been observed (is observed). The structure of a target algebra \mathcal{A}_i is very simple and posses more a formal

meaning here. The target algebras are needed if we will go over to the corresponding product space for a common description of all aspects M_1, \dots, M_k .

3.) Let $Q_i : \mathcal{A}_i \rightarrow [0, 1]$ be an additive function from our target algebra into the interval $[0, 1]$ where to any given real number q_i , $0 \leq q_i \leq 1$,

$$Q_i(A_{i1}) = q_i, \quad Q_i(\overline{A}_{i1}) = 1 - q_i \quad \text{and} \quad Q_i(\Omega_i) = 1$$

holds. The values of numbers q_i and $1 - q_i$ are or can be interpreted as evaluation values for the target structures A_{i1} and \overline{A}_{i1} . In this sense the values q_i and $1 - q_i$ are an evaluation distribution over the target algebra \mathcal{A}_i . The function Q_i is a normalised measure on $(\Omega_i, \mathcal{A}_i)$. We denote $Q_i(A_{i1})$ as *score* that the target in sense of aspect M_i has been reached (is reached), analogously $Q_i(\overline{A}_{i1})$ is the corresponding score that the target in sense of M_i has not been reached (is not reached).

The triples $(\Omega_i, \mathcal{A}_i, Q_i)$, $i = 1, \dots, k$, are elementary measure spaces. We now will combine the so obtained spaces for the aspects M_1, \dots, M_k to a product space. By this product space an evaluation of more complex target structures with respect to the aspects M_1, \dots, M_k becomes possible. For the measure theoretical background used in this paper we refer to [2], for instance.

2.2 A product space for the aspects

Describing more complex target structures we now consider the product space over the measure spaces $(\Omega_i, \mathcal{A}_i, Q_i)$ for $i = 1, \dots, k$. This space consists of three elements Ω , \mathcal{A} and Q again which are defined as follows.

1.) Let $\Omega = \Omega_1 \times \dots \times \Omega_k$ be the cross product over the target spaces $\Omega_1, \dots, \Omega_k$. The elements of Ω are $\omega = \{\omega_1, \dots, \omega_k\}$ with $\omega_i \in \Omega_i$ for $i = 1, \dots, k$. We denote these elements as *k-dimensional elementary targets* and Ω is then the *k-dimensional target space*.

2.) Let \mathcal{A} be the set of all subsets of *k-dimensional target space* Ω . This set of subsets forms again a σ -algebra over the target space Ω . The elements of σ -algebra \mathcal{A} are denoted as *k-dimensional target structures*. The σ -algebra \mathcal{A} is then *k-dimensional target algebra*.

Some examples of target structures:

- $A = \{\{\omega_{11}, \omega_{21}, \dots, \omega_{k1}\}\}$ - all single targets A_{11}, \dots, A_{k1} in sense of aspects M_1, \dots, M_k have been reached (are reachable),
- $B = \{\{\omega_{11}, \dots, \omega_{k-11}, \omega_{k1}\}, \{\omega_{11}, \dots, \omega_{k-11}, \omega_{k2}\}\}$ - the single targets A_{11}, \dots, A_{k-11} have been reached (are reachable),
- $C = \{\{\omega_{11}, \omega_{21}, \dots, \omega_{k-11}, \omega_{k2}\}\}$ - the targets A_{11}, \dots, A_{k-11} have been reached, but not the target A_{k1} ,
- $D = \{\{\omega_{11}, \omega_{22}, \dots, \omega_{k2}\}\}$ - only the single target A_{11} has been reached (is reached),
- $E = \{\{\omega_{11}, \omega_{2i_2}, \dots, \omega_{ki_k}\}, i_2, \dots, i_k \in \{1, 2\}\}$ - the single target $A_{11} \in \mathcal{A}_i$ has been reached. It holds $E = A_{11} \times \Omega_2 \times \dots \times \Omega_k$, $A_{11} = \{\omega_{11}\} \in \Omega_1$.

The last target structure E is a special target structure which is directed only to the single

target or aspect M_1 . Our target algebra \mathcal{A} contains of k such single target structures which are given by

$$\begin{aligned} A_1 &= A_{11} \times \Omega_2 \times \dots \times \Omega_k, & A_{11} &= \{\omega_{11}\} \in \mathcal{A}_1, \\ A_2 &= \Omega_1 \times A_{21} \times \dots \times \Omega_k, & A_{21} &= \{\omega_{21}\} \in \mathcal{A}_2, \\ &\dots & & \\ A_k &= \Omega_1 \times \Omega_2 \times \dots \times A_{k1}, & A_{k1} &= \{\omega_{k1}\} \in \mathcal{A}_k. \end{aligned} \quad (1)$$

We denote these target structures as *simple target structures* or *simple targets*.

Beside of the single target structures a further class of special target structures is of interest. This is the class of composed target structures. A target structure B is said to be a *composed target structure* if a subset of simple target structures $\{A_{i_1}, \dots, A_{i_j}\} \in \mathcal{A}, 1 \leq i_1 < i_2 < \dots < i_j \leq k, 2 \leq j \leq k$, exists such that

$$B = \bigcup_{r=1}^j A_{i_r}$$

holds. Composed target structures are directed to subsets of targets in sense of the given target or aspect set M_1, \dots, M_k . Our target algebra \mathcal{A} contains $2^k - 1$ different composed target structures. These are

$$A_1, \dots, A_k, \quad A_1 \cup A_2, \dots, A_{k-1} \cup A_k, \quad A_1 \cup A_2 \cup A_3, \dots, \quad \bigcup_{i=1}^k A_i = \Omega.$$

Because of the set system \mathcal{A} as the set of all subsets of Ω is a σ -algebra it holds:

$$\begin{aligned} \text{(i)} \quad A_1, \dots, A_r \in \mathcal{A} &\Rightarrow \bigcup_{i=1}^r A_i \in \mathcal{A}, \\ \text{(ii)} \quad A \in \mathcal{A} &\Rightarrow \overline{A} \in \mathcal{A}. \end{aligned}$$

This implies moreover $A_1, \dots, A_r \in \mathcal{A} \Rightarrow \bigcap_{i=1}^r A_i \in \mathcal{A}$. So beside the union of target structures and the complement of a target structure also the intersection of target structures is again a target structures. That means, the target algebra \mathcal{A} is logical closed or consistent with respect to application of set theoretical operations to target structures.

3.) Let $Q : \mathcal{A} \rightarrow [0, 1]$ be a map from the target algebra \mathcal{A} into the interval $[0, 1]$ with the following property. For any $A = A'_1 \times \dots \times A'_k$ with $A'_i \in \mathcal{A}_i, i = 1, \dots, k$, it holds

$$Q(A) = \prod_{i=1}^k Q_i(A'_i). \quad (2)$$

Then, in sense of measure theory, Q is the so-called product measure of measures $Q_i, i = 1, \dots, k$. This is according to the Hahn-Kolmogorov-Theorem of general measure theory a unique defined measure on measurable space (Ω, \mathcal{A}) .

Hence by the product measure Q a measure value $Q(A)$ is defined for each target structure $A \in \mathcal{A}$. The value $Q(A)$ can be interpreted then as an evaluation number for it how the

targets in sense of target structure A have been reached (can be reached). In this sense big values $Q(A) \approx 1$ are a hint that the targets in sense of target structure A have been reached essentially, whereas a value $Q(A) \approx 0$ is a signal that targets in sense of target structure A has been failed essentially. In this sense we will denote $Q(A)$ as *score for it that the targets of target structure A have been reached (can be reached)* or, more short, simply as the *score of target structure A* .

Collecting this together, the triple (Ω, \mathcal{A}, Q) forms a corresponding product space which allows an evaluation of all target structures of target algebra \mathcal{A} by means of a score measure Q defined by (2).

2.3 Calculation rules for scores

We will consider now some calculation rules for the computation of scores of target structures. The score Q defined by (2) is a normalised measure on (Ω, \mathcal{A}) . Each normalised measure posses the following basic properties.

1. **Additivity:** According to the addition axiom of measure theory the following rule holds. Let $A_1, \dots, A_n \in \mathcal{A}$ be pairwise disjoint target structures such that $A_i \cap A_j = \phi$ for $i \neq j$ and $i, j = 1, \dots, n$ holds then we have

$$Q\left(\bigcup_{i=1}^n A_i\right) = \sum_{i=1}^n Q(A_i).$$

2. **Normalisation rule:** It holds

$$Q(\Omega) = 1.$$

Basing on these two properties further calculation rules can be obtained. The most important rules are the following. These are standard properties of each normalised measure. They hold correspondingly for the score measure Q considered here. We give a short survey.

3. **Complement rule:** Let $A \in \mathcal{A}$ be an arbitrary target structure. Then it holds

$$Q(A) = 1 - Q(\bar{A}).$$

Proof. This is a standard property of any normalised measure. \square

4. **General addition rule:** Let $A_1, \dots, A_r \in \mathcal{A}$ be arbitrary target structures. Then it holds

$$Q(A_1 \cup A_2) = Q(A_1) + Q(A_2) - Q(A_1 \cap A_2)$$

as well as

$$Q\left(\bigcup_{i=1}^r A_i\right) = \sum_{i=1}^r Q(A_i) - \sum_{\substack{i,j=1 \\ i < j}}^r Q(A_i \cap A_j) + \sum_{\substack{i,j,k=1 \\ i < j < k}}^r Q(A_i \cap A_j \cap A_k) - \dots + (-1)^{n+1} Q(A_1 \cap \dots \cap A_r)$$

Proof. This rule corresponds the general addition rule of measure theory. \square

Now we will consider some calculation rules which are of special interest in context of evaluation of target structure.

5. Product rule for simple target structures: Let $A_1, \dots, A_r \in \mathcal{A}$ be simple target structures in sense of relation (1) with $Q(A_i) = q_i$, $0 \leq q_i \leq 1$, for $i = 1, \dots, r$, $r \leq k$. Then we have

$$Q\left(\bigcap_{i=1}^r A_i\right) = \prod_{i=1}^r q_i.$$

Proof. Without of any loss of generality we suppose that the simple target structures $A_1, \dots, A_r \in \mathcal{A}$ are directed to the first r aspects M_1, \dots, M_r . Then we have

$$\bigcap_{i=1}^r A_i = A_{11} \times \dots \times A_{r1} \times \Omega_{r+1} \times \dots \times \Omega_k \quad \text{with} \quad A_{i1} \in \mathcal{A}_i, i = 1, \dots, r.$$

By (2) we get then

$$Q\left(\bigcap_{i=1}^r A_i\right) = Q_1(A_{11}) \cdots Q_r(A_{r1}) Q_{r+1}(\Omega_{r+1}) \cdots Q_k(\Omega_k). \quad (3)$$

For simple target structures it holds $Q(A_i) = Q_i(A_{i1})$. With $Q(A_i) = q_i$ for $i = 1, \dots, r$ and $Q_i(\Omega_i) = 1$ for $i = r + 1, \dots, k$. This implies

$$Q\left(\bigcap_{i=1}^r A_i\right) = \prod_{i=1}^r Q_i(A_{i1}) = \prod_{i=1}^r Q(A_i) = \prod_{i=1}^r q_i. \quad \square$$

6. Addition rule for simple target structures: Let $A_1, \dots, A_r \in \mathcal{A}$ be simple target structures where A_i is only directed to aspect M_i with $Q(A_i) = q_i$, $i = 1, \dots, r$. Then it holds

$$Q\left(\bigcup_{i=1}^r A_i\right) = 1 - \prod_{i=1}^r (1 - q_i). \quad (4)$$

Proof. By means of the complement rule and de Morgan's rule we obtain

$$Q\left(\bigcup_{i=1}^r A_i\right) = Q\left(\overline{\bigcap_{i=1}^r \overline{A_i}}\right) = 1 - Q\left(\bigcap_{i=1}^r \overline{A_i}\right) = 1 - Q\left(\bigcap_{i=1}^r \overline{A_i}\right).$$

With product measure property of Q and again by the complement rule we get

$$Q\left(\bigcap_{i=1}^r \overline{A_i}\right) = \prod_{i=1}^r Q(\overline{A_i}) = \prod_{i=1}^r (1 - Q(A_i)) = \prod_{i=1}^r (1 - q_i).$$

Collecting this together we get relation (4). \square

A special case is the case $r = 2$. Then we have

$$Q(A_1 \cup A_2) = 1 - (1 - q_1)(1 - q_2) = q_1 + q_2 - q_1 q_2.$$

7. Product rule for composed target structures: Let $B_1, \dots, B_r \in \mathcal{A}$ be r , $1 \leq r \leq k$, composed target structures with

$$B_i = \bigcup_{j=1}^{n_i} A_{ij}, \quad (5)$$

generated by n_i disjoint simple target structures $A_{ij} \in \mathcal{A}$ with $Q(A_{ij}) = q_{ij}$ for $i = 1, \dots, r$, $j = 1, \dots, n_i$, $\sum_{i=1}^r n_i = n$. Let $C \in \mathcal{A}$ be a target structure defined by

$$C = \bigcap_{i=1}^r B_i = \bigcap_{i=1}^r \bigcup_{j=1}^{n_i} A_{ij}. \quad (6)$$

Then it holds

$$Q(C) = Q\left(\bigcap_{i=1}^r B_i\right) = Q\left(\bigcap_{i=1}^r \bigcup_{j=1}^{n_i} A_{ij}\right) = \prod_{i=1}^r Q\left(\bigcup_{j=1}^{n_i} A_{ij}\right) = \prod_{i=1}^r \left(1 - \prod_{j=1}^{n_i} (1 - q_{ij})\right). \quad (7)$$

Proof. For each composed target structure $B_i = \bigcup_{j=1}^{n_i} A_{ij}$, $i = 1, \dots, r$, we consider the corresponding product measure space $(\Omega^{(i)}, \mathcal{A}^{(i)}, Q^{(i)})$ generated by the measure spaces $(\Omega_{ij}, \mathcal{A}_{ij}, Q_{ij})$, for the aspects M_{ij} , $j = 1, \dots, n_i$. As above, the product measures $Q^{(i)}$ are defined by

$$Q^{(i)}(A_{i1} \times \dots \times A_{in_i}) = Q_i(A_{i1}) \cdots Q_{in_i}(A_{in_i}), \quad A_{ij} \in \mathcal{A}_{ij}, \quad j = 1, \dots, n_i.$$

Let $A_1^{(i)}, \dots, A_{n_i}^{(i)} \in \mathcal{A}^{(i)}$ be simple target structures of target algebra $\mathcal{A}^{(i)}$ directed to the aspects M_{i1}, \dots, M_{in_i} with $Q^{(i)}(A_j^{(i)}) = q_{ij}$, $j = 1, \dots, n_i$. Then for a composed target structure $B_i = \bigcup_{j=1}^{n_i} A_j^{(i)} \in \mathcal{A}^{(i)}$ according the addition rule for simple target structures holds

$$Q^{(i)}(B_i) = Q^{(i)}\left(\bigcup_{j=1}^{n_i} A_j^{(i)}\right) = 1 - \prod_{j=1}^{n_i} (1 - q_{ij}). \quad (8)$$

If we now consider the product of measure spaces $(\Omega^{(1)}, \mathcal{A}^{(1)}, Q^{(1)}), \dots, (\Omega^{(r)}, \mathcal{A}^{(r)}, Q^{(r)})$ then we obtain again the measure space (Ω, \mathcal{A}, Q) .

The corresponding product measure Q is then defined as follows. For any target structure $C = B_1 \times \dots \times B_r \in \mathcal{A}$, $B_i \in \mathcal{A}^{(i)}$, $i = 1, \dots, r$, we have

$$Q(C) = Q(B_1 \times \dots \times B_r) = Q^{(1)}(B_1) \cdots Q^{(r)}(B_r).$$

This, together with (8) completes the proof. \square

Of course the product rule (7) holds too if we consider r , $2 \leq r \leq k$, disjoint composed target structures where the included simple target structures form only a subset of all simple target structures of target algebra \mathcal{A} . Hence it is possible to evaluate by formula (7) also target structures in sense of (5) which refer itself only to a subset of all possible simple target structures.

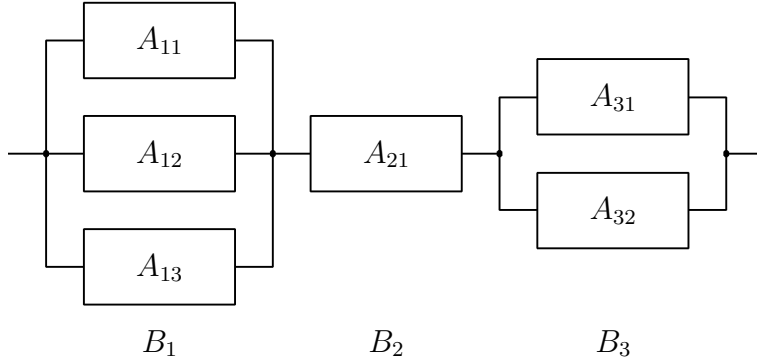

Figure 1. Visualisation of target structures in sense of product rule for composed target structures.

2.4 Graphical representation of target structures

Target structures in sense of product rule for composed target structures can be visualised by means of logical diagrams as they are used in reliability theory, for instance.

Let C be a target structure given by

$$C = B_1 \cap B_2 \cap B_3$$

with

$$B_1 = A_{11} \cup A_{12} \cup A_{13}, \quad B_2 = A_{21} \quad \text{and} \quad B_3 = A_{31} \cup A_{32}$$

where $A_{11}, A_{12}, A_{13}, A_{21}, A_{31}$ and A_{32} are disjoint simple target structures. Then the targets in sense of target structure C are reached if at least one of simple targets A_{11}, \dots, A_{13} and the target A_{21} and at least one of the targets A_{31} or A_{32} are reached. Figure 1 shows the associated target diagram. The composed target structures are described by a parallel circuit, the intersection of the composed target structures is visualised by a series circuit.

By repeated application of the addition rule for simple target structures and the product rule for composed target structures very complex target structures can be evaluated. The logical background of these target structures can be visualised by corresponding target diagrams.

3 Estimation of scores for target structures

In the previous section it has been shown how scores can be calculated for complex target structures. By the calculation rules considered there the scores can be reduced to the scores q_1, \dots, q_k of the simple target structures of target algebra \mathcal{A} . Unfortunately, as a rule these scores are not given a-priori and we need corresponding estimation methods for these scores as well as for the scores of composed target structures.

We assume that aspects M_1, \dots, M_k can be observed indirectly by means of ordinal or metrical ordered observation variables X_1, \dots, X_k . Let $\mathcal{X}_i = [x_i^{(0)}, x_i^{(1)}]$ be the domain of i -th observation variable X_i for $i = 1, \dots, k$. Big values of X_i in the neighbourhood of $x_i^{(1)}$ are an indication

of that the target in sense of aspect M_i has been reached, essentially. Small values in the neighbourhood of $x_i^{(0)}$ a corresponding signal that the target has been failed, essentially. The observation values $X_i = x_i^{(1)}$ or $X_i = x_i^{(0)}$ indicate that the target in sense of aspect M_i has been completely reached or failed, respectively. The scales which are used for observing the variables X_i can be continuous or discrete, must be ordered and can be, for instance, rank places too.

We now consider a sample of size n of our observation vector $\vec{X} = (X_1, \dots, X_k)$. Such a sample can be obtained, e.g., by a corresponding interrogation of participants of an e-learning program via an assessment checklist after the course is finished. This would be an a-posteriori-interrogation. Or, one could interrogate experts which evaluate the course based on the course materials before the course is held. This would be an a-priori-interrogation.

Let $\vec{X}_i = (X_{i1}, \dots, X_{ik})$ be the i -th element of our sample $\vec{X} = (\vec{X}_1, \dots, \vec{X}_n)$. Then at first we have to normalise our sample values X_{i1}, \dots, X_{ik} by transforming of these values to the interval $[0, 1]$, the domain for our scores q_1, \dots, q_k . This can be reached by the following transformation. For $i = 1, \dots, n$ and $j = 1, \dots, k$ let $q_j^{*(i)}$ be defined by

$$q_j^{*(i)} = \frac{X_{ij} - x_j^{(0)}}{x_j^{(1)} - x_j^{(0)}}. \quad (9)$$

Then $q_j^{*(i)}$ is an estimation for the score q_j based on the observation X_{ij} . That means, each observation vector $\vec{X}_i = (X_{i1}, \dots, X_{ik})$, $i = 1, \dots, n$, is transformed first by the normalisation rule (9) into a score vector

$$\vec{q}^{*(i)} = (q_1^{*(i)}, \dots, q_k^{*(i)}).$$

By means of these transformed or normalised sampling values the score of composed target structures can be estimated as follows. We consider a composed target structure C in sense of relation (6) with a score according (7). For each sample element $\vec{q}^{*(i)} = (q_1^{*(i)}, \dots, q_k^{*(i)})$, $i = 1, \dots, n$, of our normalised sample $\vec{q}^* = (\vec{q}^{*(1)}, \dots, \vec{q}^{*(n)})$ we obtain an estimation $Q^{*(i)}(C)$ for $Q(C)$ if we substitute in formula (7) the scores q_{ij} by the estimations $q_{ij}^{*(i)}$. We get

$$Q^{*(i)}(C) = \prod_{j=1}^r \left(1 - \prod_{l=1}^{n_j} (1 - q_{jl}^{*(i)}) \right) \quad (10)$$

for $i = 1, \dots, n$. The vector $(Q^{*(1)}(C), \dots, Q^{*(n)}(C))$ is then a sample of size n for $Q(C)$. By means of the method of moments we obtain via the arithmetic mean

$$Q^*(C) = \frac{1}{n} \sum_{i=1}^n Q^{*(i)}(C)$$

finally an estimation function for the score $Q(C)$ by

$$Q^*(C) = \frac{1}{n} \sum_{i=1}^n Q^{*(i)}(C) = \frac{1}{n} \sum_{i=1}^n \prod_{j=1}^r \left(1 - \prod_{l=1}^{n_j} (1 - q_{jl}^{*(i)}) \right). \quad (11)$$

This is the main formula for estimating of the score of a composed target structure based on a sample of size n in context of an interrogation.

Special cases are again the composed and simple target structures. For single composed target structures $B = \cup_{j=1}^r A_j$ we get according the addition rule for simple target structures as estimation function

$$Q^*(B) = Q^*\left(\bigcup_{j=1}^r A_j\right) = \frac{1}{n} \sum_{i=1}^n \left(1 - \prod_{j=1}^r (1 - q_j^{*(i)})\right). \quad (12)$$

For simple target structures $A_1, \dots, A_r \in \mathcal{A}$ we get by the product rule for simple target structures as estimation for the score of $B = \cap_{j=1}^r A_j$

$$Q^*(B) = Q^*\left(\bigcap_{j=1}^r A_j\right) = \frac{1}{n} \sum_{i=1}^n \prod_{j=1}^r q_j^{*(i)}. \quad (13)$$

The score $q_j = Q(A_j)$ of a single simple target structure $A_j \in \mathcal{A}$ can be estimated by

$$Q^*(A_j) = \frac{1}{n} \sum_{i=1}^n q_j^{*(i)}. \quad (14)$$

In case of missing values in the sample the missing values for $q_{jl}^{*(i)}$ can be substituted then by the estimation values $Q^*(A_{jl})$ which are obtained based on the incomplete sample. This corresponds a 'neutral' evaluation of missing values in the sample.

References

- [1] E-learning quality, Aspects and criteria for evaluation of e-learning in higher education. Höskoleverket, Swedish National Agency for Higher Education, Report 2008:11 R.
- [2] Bauer, H. (2001): Measure and Integration Theory. Gruyter - de Gruyter Studies in Mathematics, Berlin.
- [3] Ehlers, U.-D., Pawlowski, J.M. (2006): Handbook of Quality and Standardisation in E-Learning. Springer Heidelberg.
- [4] Grif, M., Uranchimeg, T., Tsoi, E.B. (2004): Man Machine Systems Design Methods, KORUS 2004, Proceedings, pp. 42-45.
- [5] Khan, B.K.(2005): Managing e-learning: Design, delivery, implementation and evaluation. Hershey, PA: Information Science Publishing.
- [6] Kirkpatrick, D. L. (1998): Evaluating Training Programs. The Four Levels. San Francisco.
- [7] Stufflebeam, D.L. (2002): The CIPP Model for Evaluation. In: Stufflebeam, D.L., Madaus, G.F., Kellaghan, T.: Evaluation Models. Viewpoints on Educational and Human Services Evaluation. Second Edition, e-Book, New York, pp. 290-317.

- [8] Uranchimeg, T., Batshagai, B. (2010): Research and usage of virtual laboratory in teaching. Proceedings of 'International Conference of 50th Anniversary of Power Engineering School of MUST', Ulaanbaatar, pp. 26-31.
- [9] Zaharias, P., Poulymenakou, A. (2009): Developing a usability evaluation method for e-learning applications: beyond functional usability. International Journal of Human-Computer Interaction, Vol. 25 (1), pp. 75-98.