

James Madison University  
**JMU Scholarly Commons**

---

Masters Theses

The Graduate School

---

Spring 2014

# Auditory masking in spontaneously hypertensive rat: An examination of the continuum of impulsivity

John Joseph O'Malley  
*James Madison University*

Follow this and additional works at: <https://commons.lib.jmu.edu/master201019>

 Part of the [Psychology Commons](#)

---

## Recommended Citation

O'Malley, John Joseph, "Auditory masking in spontaneously hypertensive rat: An examination of the continuum of impulsivity" (2014). *Masters Theses*. 283.  
<https://commons.lib.jmu.edu/master201019/283>

This Thesis is brought to you for free and open access by the The Graduate School at JMU Scholarly Commons. It has been accepted for inclusion in Masters Theses by an authorized administrator of JMU Scholarly Commons. For more information, please contact [dc\\_admin@jmu.edu](mailto:dc_admin@jmu.edu).

Auditory masking in spontaneously hypertensive rat: An examination of the continuum of  
impulsivity

J.J. O'Malley

A thesis submitted to the Graduate Faculty of

JAMES MADISON UNIVERSITY

In

Partial Fulfillment of the Requirements

For the degree of

Master of Arts

Psychology

May 2014

## Acknowledgements

I would like to thank my team of undergraduates for their dedication to science and for their help collecting my thesis data. I would also like to thank my cohort for their time. Without our team none of this would have been possible. I am happy that I had the opportunity to work with all of you and hope for the best for each and every single one of you.

I would also like to thank Colleen Johnson for all her help.

Lastly, I would like to thank Drs. Irons, Holt, Dyche and Gray for their guidance. From them I have learned so much about the research process and life as well.

## Table of Contents

Acknowledgments.....	ii
List of Figures.....	iv
Abstract.....	v
Introduction.....	1
Background	
Signal detection theory and behavioral psychology	
False alarms as a measure of impulsivity	
Audibility of the rat	
Research purpose	
Method.....	10
Subjects	
Apparatus	
Procedure	
Results.....	14
Average accuracy	
Average false alarm rate	
WIS-4-2	
Discussion.....	15
Future directions	
Conclusion	
Appendixes.....	20
References.....	26

## List of Figures

Figure 1 .....	20
Figure 2 .....	21
Figure 3 .....	22
Figure 4 .....	23
Figure 5 .....	24
Figure 6 .....	25

## Abstract

Signal detection theory can measure impulsive behavior. To further examine this paradigm, the researcher attempted to replicate previous findings with more experimental control and examine impulsive behaviors in a putative model of Attention Deficit/Hyperactivity Disorder, the Spontaneously Hypertensive Rat. Four strains of rats attempted to discriminate between the presence and absences of a 3 kHz tone within a 5-6 kHz masker; however, only one rat reached stabilization. To aid in training and reduce difficulty of the task, the researcher presented the rat with forced-choice trials. Although the additional training increased their variability of correct responses, rats were unable to reach the stability criterion. The complexity of the task could account for low stabilization rates. The methodology could be used to create experimental designs to further investigate impulsivity through auditory discrimination using simpler tasks.

## Auditory masking in spontaneously hypertensive rat: An examination of the continuum of impulsivity

Choice is ever apparent, but not all decisions lead to good choices. Impulsive choices can be characterized by risk taking and impatient behaviors (Green & Myerson, 2013). Green and Myerson argue that impulsive behaviors become apparent from the consequences of the behaviors. These consequences are signaled by cues in the environment, and impulsive behaviors occur without attending to all cues. Impatient behaviors occur without considering the cues for long term consequences and risk behaviors occur without considering the cues for risk.

Impulsivity is measured in the laboratory via several methods. One measure of impulsive behaviors, more specifically risk taking behavior, is the Balloon Analog Risk Task (BART) (Hunt, Hopko, Bare, Lejuez & Robinson, 2005). The goal of the BART is to obtain as much money as possible. To obtain money the participants need to inflate a balloon, but by inflating the balloon participants run the risk of it popping, losing all money they had earned from inflating it. Another measure of risk is the Iowa Gambling Task (IGT). In the task participants try to maximize profit and have the option to choose consequences that initially seem like a relatively larger gain but over time result in a net loss and consequences that seem like a relatively small gain but in the long term result in a net profit. Participants with deficits in decision making do not perform as well on the task (Buelow & Suhr, 2009) and this may be due to those participants' inability to attend to certain cues. Discounting can also measure impulsive behaviors, both risk taking, though probability discounting, and impatient behaviors through delay discounting (Holt, Green, & Meyerson, 2003). Gray, Breirer, Foorman, & Fletcher (2002) used Signal Detection Theory (SDT) to measure impulsivity.

To measure impulsivity using SDT, Grey et al. (2002) and Breier, Gray, Klass, Fletcher and Foorman (2002) measured the False Alarm (FA) rates of children diagnosed with Attention Deficit/Hyperactivity Disorder (ADHD) in a Central Auditory Masking Task and an Informational Masking Task. In Central Masking, the masking occurs within the neural processing networks of the brain, or central to the organism. The participants hear noise in one ear and either a target tone or nothing in the other. Because there is direct stimulation of the ear, any error can be attributed to neural processing. Also, the direct stimulation of the ear minimizes any extraneous noise from the environment, so there is no peripheral or mechanical interference, allowing for the experimenter to directly manipulate the aspects of noise to create a moderately difficult task. In Informational Masking, participants are presented with a complex stimulus and the target tone may or may not be present. The tone and noise are presented to participants as one complex stimulus; however there is no direct stimulation. Instead the stimulus is presented in the environment and participants process all the information given including extraneous ones from the environment, creating more possible noise. So, a central masking task can be seen as less difficult than an informational one.

Grey et al. (2002) and Breier et al. (2002) found that in a relatively simple task like a single tone discrimination, all participants had low rates of FAs, and at relatively a difficult task, like Informational Masking, participants had a high rate of FAs, suggesting that there may be a continuum of impulsivity (see figure 1). The most interesting finding was in intermediately difficult tasks, such as Central Masking, participants who had been diagnosed with ADHD had a significantly higher rate of FAs when compared to non-ADHD participants. These data suggest that those who behave impulsively in the past may be differentially affected by intermediately difficult tasks, which could likely occur in many common listening situations, such as grade-



school classrooms and put children with ADHD at risk of hearing deficits unnoticed by those without ADHD. To further understand the implications of these findings, a better understanding of signal detection is needed as these methods are based on this well documented theory.

### **Signal detection theory and behavioral psychology**

The principle assumption behind SDT is that the organism senses a signal in the presence of some noise (Green and Swets, 1966). In other words, signal detection is an objective measure of a subjective choice such as deciding whether or not you think the phone is ringing while in the shower. This measure is based on two possible conditions, either a target signal is present (i.e. phone is actually ringing) or it is not, with two possible outcomes in each condition. Those outcomes are based on two possible responses, either an organism reports sensing a signal or reports not sensing a signal. Based on these options there are four possible outcomes: a hit (reporting a signal when it occurs), a miss (reporting no signal when it occurs), a correct rejection (reporting no signal when there is none), or a false alarm (reporting a signal when there is none). In the phone example, if you get out of the shower to answer the phone and it is actually ringing, that would be considered a hit. If you got out and the phone was not ringing, that would be considered a false alarm. A correct rejection would be if you stayed in the shower and the phone was not ringing. And lastly if the phone was ringing and you decided that it was not and stayed in the shower that would be considered a miss.

Because of the possible responses hits are indirectly proportional to misses and false alarms are indirectly proportional to Correct Rejections. Also the sum of the probabilities of hits and misses is 1 and the sum of false alarms and correct rejects is 1 assuming signal present and signal absent trials are equal (Green and Swets, 1966). This is because hits and misses are related to the same hypothesis, that the stimulus is present. Correct rejections and false alarms are

related to the other possible hypothesis, that the stimulus is not present. Therefore, the minimum amount of information needed to calculate accuracy is hits and false alarms. The ratio of standardized hits to standardized false alarms is referred to as the statistic  $d'$ . It is calculated as:

$$d' = z(\text{hit rate})/z(\text{false alarm rate})$$

where the higher the  $d'$ , the more accurate the organism is.

Signal Detection Theory is closely related to behavioral psychology and has been suggested by Nevin (1969) that signal detection should be considered in interpreting operant choice behavior. The major connection between the two fields is feedback and stimulus control. In signal detection an organism is presented with a stimulus, it responds yes or no, and feedback is given. The same is true for behavioral psychology; an organism is presented with a stimulus, it responds, and it is provided with reinforcement (i.e. feedback). So there are three factors that drive responding: the *a priori* probability of a signal occurring, the magnitude of reinforcement, and the signal strength. If the probability of signal presentation is held to 50% and the amount of reinforcement is the same for either correct response (hit or correct rejection), then manipulating the strength of a signal can determine the effects the strength has on responding.

Operant psychology aims to understand what variables affect an organisms responding and as such can be used to understand how a signal can affect responding. In operant discrimination there are two major factors that determine the response of an organism, the stimulus that sets the occasion for responding and the consequence of the response (Catania, 2013; Cooper, Heron and Heward, 2007; Davison and Nevin, 1999). This is known as the three term contingency:

$$S^D: R \rightarrow S^{R+}$$

where R stands for the response,  $S^{R+}$  stands for the consequence (in this case positive reinforcement) and  $S^D$  stands for discriminative stimulus. The terms used in behaviorism match terms in signal detection. The  $S^D$  for behaviorism is the signal or cue for SDT and  $S^A$  is just noise. The R shown above is a response for both paradigms. The  $S^{R+}$  is simply feedback for SDT. The rate of responding is dictated by the rate of reinforcement or schedule of reinforcement (Ferster and Skinner, 1957; Herrnstein, 1970; Baum 1974). Herrnstein (1970) and later Baum (1974) showed that the matching of responding to rate of reinforcement can be mathematically calculated in the matching law. However, if the reinforcement is held constant, choice behavior does not necessarily match if a signal occasions responding (Davison and Nevin, 1999; Davison and Tustin, 1978). As such, responding can be put under the control of stimuli that signal the occasion to respond for reinforcement. This is known as stimulus control and is shown by either  $S^D$  or  $S+$  and either  $S^A$  or  $S-$  and  $S^D$  or  $S+$  signals the opportunity for reinforcement whereas  $S^A$  or  $S-$  does not (Dinsmoor, 1985, 1995a, 1995b). The more an organism experiences  $S^D$  and  $S^A$  contingencies the more control the stimulus has over the organism's behavior.

During discrimination with multiple signals there is more than one  $S^D$  and  $S^A$ . The organism learns two separate contingencies Tone1-R1 and Tone2-R2. So, in the presence of Tone1 the organism must press the left lever to receive a food reward, and in the presence of Tone2 the organism must press the right lever to receive the food reward. When an organism begins to learn this distinction, both contingencies affect its learning. That is, the relation between Tone1-R1 can inhibit responding to the Tone2-R2 contingency (Catania, 2013).

Dinsmoor (1995b) stresses the importance of two factors that can influence stimulus control: the physical difference between  $S^D$  and  $S^A$  which he calls disparity, and the physical

difference between  $S^D$  and any background noise which he calls saliency. Both of these factors can affect the accuracy in discriminating between  $S^D$  and  $S^A$ .

Taking these two factors into account, another way of merging signal detection and operant psychology emerges through  $d'$ . That is,  $d'$  can be thought of as a measure of saliency or the magnitude of stimulus control when noise is present. However because  $d'$  is based on subjective responding it is important to know if an organism can physically detect a signal (i.e., sense) and the threshold theory of signal detection and classical psychophysics measures that. In other words, a signal may be present but the organism cannot sense it, this is, it is below its sensory threshold. For example, a rat may be presented with a 15 dB tone at 2000 Hz but respond as if it did not detect a tone. However, if the same tone is presented at 60 dB the rat responds as if it heard the tone. The tone at 15 dB is below the rat's threshold for the intensity of the particular frequency of the tone. By systematically changing the amplitude or intensity of a sound the rat's threshold becomes apparent.

Threshold for an organism is calculated usually at 50% correct responding based on seminal work by Gustav Fechner in the 19<sup>th</sup> C. There are currently several ways of calculating the threshold but all are based on the modern principles of discrimination. That is, thresholds are merely the smallest unit of differences between two stimuli that an organism can detect. In other words, discrimination is not dependent upon the differences in physical characteristics of the stimuli per se, but whether the organism can detect those differences.

### **False Alarms as a measure of impulsivity**

Baum (1973) states that no behavior occurs in isolation, but in a context. The behavioral paradigm takes this into account through  $S^D$ s, and  $S^{R+}$ s. In SDT the context is the signal and the feedback. These are direct and observable variables in the context but, as SDT proposes, noise is

always present and behavior is measured with the assumption that there is noise and that the organism can still detect the signal. Part of that noise may be the stimulus control of the other contingency, especially if the stimuli are physically similar, which may cause the stimuli to overlap and be perceived as the same. So, conflicting contingencies may deter attenuating to cues.

Impulsivity is related to the  $d'$  equation by examining the incorrect responding in the presence of cues within noise. According to SDT, cues do not appear in isolation but in the presence of noise. This noise can make the detection of a signal more difficult, thus lowering the  $d'$  or stimulus control, which measures the rate of correct responses relative to error when the stimulus is present. Impulsivity can be measured by  $d'$  prime through FA rates because impulsivity has been implicated as an inability to attend to the beneficial cues perhaps through lack of response inhibition. Therefore, impulsivity can be measured by examining FA rate. The idea behind this is that impulsivity manifests itself through impatient and risky behaviors and, in turn, the rate of error will increase because the organism is less likely to consider the presented stimulus. Therefore, as the rate of some errors increases  $d'$  will decrease. The decrease can occur in three different ways: (1) a decrease in the rate of hits, (2) an increase in the rate of false alarms (decrease of correct rejections), or (3) a combination of hits decreasing and false alarms increasing. Because  $d'$  only needs hits and false alarms to be calculated and because both hits and FAs are dependent on the same response (e.g., pressing the left lever regardless of stimulus) the equation can be reduced to a ratio of the rate of correct responding to the rate of incorrect responding. Taking that into account with the fact that impulsivity is dependent on impatient and risky behaviors, a “yes” response without the consideration of the stimulus would resemble chance. Theoretically, impulsivity should drive the rate of correct responding closer to chance,

and as such this would increase the rate of false alarms on the “yes” button. Therefore, one may simply examine the rate of false alarms as a measure of impulsive behaviors. So, the underlying assumption is that the organism shows no bias but has an increased rate of false alarms and as such the only possibilities would be (2) or (3) so measuring the rate of false alarms is sufficient for examining impulsive behaviors.

### **Audibility of the rat**

As briefly mentioned above, certain intensities of auditory stimuli may not be detectable by the rat. However one can calculate the intensity threshold for different frequencies and plot it in an audiogram. This audiogram shows the range of audibility for each species (see Figure 2 for a depiction of the rat audiogram). Studies conducted by Gourevitch (Gourevitch, 1965; Gourevitch & Hack, 1966) as well as Borg (1982) have shown that around 3 kHz, the average threshold of detection is about 30 to 40 dB and this threshold remains relatively consistent with age and exposure. This means that a tone present well above this intensity level should theoretically be heard by all rats even with repeated exposure and aging. So, a 3 kHz tone should serve as an ideal target tone for stimulus control due to its relatively small variability in threshold over time.

It is important to note that the intensity of an auditory tone is not the only physical characteristic that can be limited by the biological constraints of an organism. The frequency or Hertz (Hz) also factors. All species can hear only certain ranges of frequencies. It is important to know the minimum audibility curve of the species before setting the occasion for responding. The rat can hear from ranges between 1 kHz to 100 kHz (Kolb and Wishaw, 2014). So a target tone of 3 kHz is well within the range of frequencies a rat can detect and could serve as an ideal tone for stimulus control.

### **Animal model of Impulsivity**

The Spontaneously Hypertensive Rat (SHR) has been used and validated as an animal model of ADHD (Sagvolden, 2000). The SHR has been shown to have more variability in its behavior as well as a steeper and shorter delay of reward gradient than the Wistar-Kyoto rat (Johansen, Killeen & Sagvolden, 2007). SHRs behave impulsively during response withholding tasks (Sanabria and Killeen, 2008) and behave hyperactively (Hill, Herbst & Sanabria, 2012). The SHR exhibits the three fundamental behaviors associated with ADHD: inattentiveness, hyperactivity, and, most important to this study, impulsivity. Many studies use three different strains as the control comparison: the Sprague-Dawley (SD) (e.g. Sagvolden, Pettersen, & Larsen, 1993), Wistar (WIS) (e.g. Prediger, Pamplona, Fernandes, & Takahashi, 2005), and Wistar-Kyoto (WKY) (e.g. Adriani, Caprioli, Granstrem, Crli, & Laviola, 2003). The WKY serves as the best genetic control for the SHR (Sagvolden et al., 2009). However, recent findings (e.g., Sagvolden et al., 1993) have suggested that the WKY differ more so than the SHR and as such other strains should also be included such as the SD and WIS rats.

### **Auditory discrimination in the rat**

Auditory stimuli have been used to establish stimulus control in the rat, however most studies conducted are successive discriminations (Harrison, 1990) in which one stimulus is presented after another. Successive discrimination is more difficult to learn than a simultaneous discrimination task (McGaughy & Sarter, 1994). But, rats can learn to discriminate at near 100% accuracy between two different intensities as little as 20 dB apart (Termin, 1970). In addition to that they can learn to distinguish between a specific frequency and noise when presented successively (Harrison, 1988) as well as simultaneously (Harrison, 1990).

Given this evidence, a rat can discriminate based on the intensity of a tone and the frequency of a tone. However it is not known if a rat can detect a tone within noise during successive discrimination. Such a task would mirror the human task from Gray et al. (2002) using human ADHD participants.

### **Research purpose**

In order to understand the continuum of impulsivity proposed by Gray et al. (2002) and examine if impulsive behaviors can be measured by FA rate, the purpose of the present experiment was to test the continuum of impulsivity as well as to provide a methodology for more experimental control and experimental analysis using signal detection. The only prediction was that the SHR would have the highest false alarm rate.

## **Method**

### **Subjects**

Thirty-two experimentally naive rats (deliverer, 8 SD, 8 SHR, 8 WIS, and 8 WKY) completed the auditory masking task. All rats arrived to the testing facility ranging from 14 to 21 post-natal days (PND). They acclimated to their housing for 1 week before any testing was conducted. During this time they were handled for 5 min each. The housing rooms were kept at a constant 70-72°C with 30-32% humidity on a reversed 12 hr light-dark cycle. After one week of handling the rats, food deprivation began. All rats had one hour free access to food and ad libitum access to water.

### **Apparatuses**

**Testing chamber.** All training took place in a Med Associates Modular test chamber (ENV-007CT) inside a sound attenuating chamber (ENV-018MD). The test chamber had two retractable levers (ENV-112CML) on the far left (3.5cm from the left wall to the center of the



lever and 18.75cm from the grid floor to the center of the lever) and far right side (3.5cm from the right wall to the center of the lever and 18.75cm from the grid floor to the center of the lever) of the front wall in the chamber. Directly below each lever were two pellet receptacles (ENV-224AM). Two pellet dispensers (ENV-203-45) dispensed 45mg pellets (*Test Diet* AIN-76A Rodent Tablet) to each pellet receptacle (3.91cm from each respective wall to the center of the receptacle and 2.5cm from the grid floor to the center of the lever). Between either receptacle was a speaker (ENV-224AM, 11.88cm from either side wall to the center of the speaker and 4.43cm from the grid floor to the center of the speaker) to present the auditory stimuli. On the opposite wall in the chamber was the house light (ENV-215M). See figure 3. All boxes were connected to a computer (COM-103A-GP) running Med-PC IV via Smart CTL cards (DIG-716B) and Smart Control Panels (SG-716B).

**Housing.** All rats were socially housed in pairs of the same strain. The 44.88cm x 23.58cm x 20cm” home cages were made of polycarbonate (Model: 18780, Lab Products Inc.) and filled with a .63cm of bedding.

**Auditory sound processor.** An RP2.1 Enhanced Real-Time Processor (*Tucker Davis Technologies*) produced the auditory stimuli sent to the chambers. The RP2.1 was connected to MED-PC via a Super Port Card (DIG-726).

**Calibrations.**

***Sound intensity within the operant chambers.*** A B&K half inch microphone (model 4176) recorded the decibel level of a 3 kHz tone in an operant chamber and it was measured by a HP3561 Spectrum Analyzer peak hold average. With the microphone directly on the speaker the tone was 84dB. With the microphone turned in the opposite direction the tone read at 80 dB. The microphone 5 cm away from the speaker picked up the tone at 81 dB (read twice). The microphone moved to 20 cm directly away from the speaker picked up the tone at 78 dB. In the right food receptacle (85 mm away from the center of

the speaker) the tone registered at 76 dB. In the left food receptacle (85 mm away from the center of the speaker) the tone registered at 82 dB. When the microphone was raised to the right lever (160 mm away from the center of the speaker) the tone registered at 75 dB. When the microphone was raised to the left lever (160 mm away from the center of the speaker) the tone registered at 82 dB.

***Sound intensity across the operant chambers.*** A B&K half inch microphone recorded the decibel level of a 3 kHz tone within a masker band ranging from 5 to 6 kHz at 80dB in an operant chamber and it was measured by a HP3561 Spectrum Analyzer peak hold average. The microphone was placed 5 mm directly away from the center of the speaker and the gain was set to -15 dB. For box 2 the 3 kHz tone registered at 77.79 dB. For box 4 the 3 kHz tone registered at 76.07 dB. For box 5 the 3 kHz tone registered at 78.32 dB. For box 6 the 3 kHz tone registered at 75.33 dB. For box 7 the 3 kHz tone registered at 76.41 dB. For box 8 the 3 kHz tone registered at 77.53 dB. For box 9 the 3 kHz tone registered at 76.69 dB. And for box 11 the 3 kHz tone registered at 76.3 dB.

**Auditory creation.** Matlab version R2013a computed and generated the auditory stimuli.

## **Procedure**

**Shaping.** After the week of acclimation all rats learned to press the levers for pellets through successive approximations. This continued until the rat successfully lever pressed on its own for 100 pellets for two consecutive days.

**Tone discrimination training.** Tone discrimination training took place at four different times of day (i.e. 11:00 am, 12:00 am, 1:00 pm, and 2:00 pm). Two rats of each strain performed in each session, controlling for any circadian effects. Once the rats were able to lever press, they were trained to complete a discrimination task using two levers. The target tone (3 kHz, 70 dB) and a masker (5-6 kHz, 70 dB) occasioned responding on one lever (e.g. the left lever) for one pellet reinforcement. Signaling of just the masker occasioned responding on the other lever (e.g.

the right lever) for one pellet reinforcement. In order to control for a side bias, half of the rats in each session trained to associate the left lever with the target tone.

The rat was presented with 200 choice probe trials in a session. Half of the choice probe trials randomly presented the target tone within the masker. The choice probe started with a 12 s intertrial interval (ITI) followed by either the presentation of the tone with the masker or just the masker for 1 s. Two seconds after the stimuli both levers were presented and the rat had a limited hold of 4 s to respond. When the rat did respond, the levers were removed and at the end of the four second interval the next trial started. When the rat did not respond within the given time, the levers were removed, the response was counted as an omission (incorrect), and the next trial started. When the rat responded correctly, it received a pellet on a FR1 schedule with a 4 s limited hold and moved on to the next choice probe trial. If the rat responded incorrectly, that response was put on extinction and moved to the next trial.

The rats continued this training with the goal of all reaching three consecutive days with more than 70% correct choices and less than 5% omissions. Once a rat reached this criterion it was considered stable and waited for all other rats in the session to stabilize before moving on to the next task. Some rats began to show a bias towards one lever (i.e. 100% of the responses to a lever over 10 days). When this occurred all rats trained with forced choice probes to correct the bias and control for any effects additional training may have had.

**Forced Choice Training.** In the forced choice training the rats completed 60 block trials that included two forced choices followed by a choice probe. During the forced choice the rat was presented with a 12s ITI followed by a 1s presentation of the target tone within the masker, then the correct lever was presented 2 s following the tone with a 4s limited hold. Next the rat was presented with a 12s ITI followed by a 1s presentation of the masker and 2s later the correct

lever was presented for 4s. The order of stimuli in which all rats were presented was randomized. Once both forced choices have been presented the rat was presented with a choice probe trial exactly like the discrimination training choice probe trial. The rats continued training with forced choices to reach the stability criterion.

## **Results**

A multiple baseline across strain design was used during the study. Visual analysis examined the change in accuracy and false alarm rates during the Auditory Discrimination training and during the Forced Choice training. However after 45 days of Auditory Discrimination the Rats performed no better than chance and after 30 days of Forced Choice training the rats still performed no better than chance.

### **Average Accuracy**

On the average, the rats did not learn the initial discrimination task. This was seen by stable rates of correct responding around chance (50%). As a result, no statistical analyses were conducted. During the Forced Choice Training variability of rates of correct responding increased, but not to stability. No statistical analyses were conducted (see figure 4 for graphical depiction).

### **Average FA Rate**

SHR, WIS and WKY rats on the aggregate level had a decreasing trend in rates of false alarms. SD rats had a relatively stable pattern of FAs around 25%. The WIS rats initially had lowest rate of FAs; however on day 27 the SHR rats FAs dropped and remained the lowest during the auditory discrimination task. Again no statistical analyses were conducted because the rats did not learn the task (see figure 5 for graphical depiction).

### **WIS-4-2**

WIS-4-2 completed the Auditory Discrimination Training after 36 Day with a stable pattern of responding of about 85% correct responding (see figure 6). During Force Choice Training, WIS-4-2 continued high rate of correct rate for eight days and was considered to have reached stability. Two Probes were conducted on days 65 and 68 to see if there was any effect of inactivity. Based on the high rate of responding and an increasing trend it was concluded that there was no effect of inactivity over a few days on the rat. Based on these data, the task shows to be able to be completed but it may be that it is far too difficult and would require many more days training

### **Discussion**

Majority of the rats in the study were not able to learn the first discrimination task and adding forced choice trial to make the task simpler only increased variability, thus not increasing the simplicity enough. Because no rats responded consistently above chance, it was determined that the rats did not learn the task and as such no statistical analyses were conducted because differences may be due to chance. The data from the current study did not support the primary hypothesis, that there would be a higher false alarm rates for the SHR. Although SHRs had relatively lower rates of FAs, they also had relatively higher rates of Misses. This is most likely due to the fact that the training the rats received was not simple enough to establish strong stimulus control. The fact that the SHR had different rates of responding but the same accuracy may be due to the fact that impulsive behaviors occur with lower stimulus control (because the % correct was at 50 for all rats but errors relatively equal shows that there was some degree of stimulus control).

False Alarm rates were lowest for the SHR inconsistent with Grey et al. (2002). Although the SHRs' rates were low, the fact that all rats had relatively the same accuracy the SHR had the

highest rate of Misses. Lower rate of FAs for the SHR suggests that FAs may not be the only measure of impulsivity, Misses should also be considered. Also that FA might measure impulsive responding to the tone lever and that misses would measure impulsive responding to the no-tone lever. Each response is mutually exclusive of one another and responding to one lever necessarily means not responding to the other. The findings here suggest that there may be some bias towards one lever over the other, which could be due to interference from the opposite lever. That is, each lever may (i.e. the number of choice) distract from the cue in the environment when the cues are too similar. As such, the relatively higher rates of Misses implies that impulsive behaviors may be due to the inability to attend to specific cues or that the cues may be too similar to detect a difference. Meaning that each lever should be considered as separate measures of impulsivity and that rate of FAs only represents impulsive responding to the tone present lever and rate of misses represents impulsive responding to the tone absent lever. If it is the case then each lever should be considered separate. Yet, the findings suggest that even though the task was not learned there may be some evidence for the SHR as a model of impulsive behavior. Elucidation of the difference would become apparent if the task was learned because rate of error should necessarily increase due to difficulty of the task.

However the rate of FAs or Misses may be due to inattention as well as impulsivity. To separate the effects of each, observing response should be added. The rat would then have to press a lever during stimulus presentation showing that the rat is observing the response, showing the rat is attending to the stimulus (Dinsmoor, 1985). Observing responses would provide rats with access to choice probes allowing for measurements of impulsive behavior.

Notwithstanding the findings that animals cannot learn task, one rat actually did learn the task demonstrating that the task was possible, but perhaps too difficult to complete in a short period of time.

### **Future directions.**

Because virtually all rats were unable learn the task, it may be that the stimuli were too similar and that the rats could not easily distinguish a difference. Below are possible suggestions to change the methodology thereby making the task experimentally viable.

*Understanding the dimensions of auditory discrimination.* One possible aspect to examine would be the effects of each dimension of the complex stimuli that affected learning of both  $S^D$ s. The ratio of tone to masker was the only aspect examine in this study. The effect of the frequency of the target tone on acquisition should be examined. This study utilized a 3 kHz tone with in a 5-6kHz masker band and other tones should be examined to see if acquisition is dependent upon the frequency used. Also the noise range and frequency should be examined. That is, this study utilized a 1000 Hz range of frequency and manipulating more or less frequencies within the range should be examined to see the effects of activating multiple critical bands within the cochlea on learning. In addition the physical distance from the target tone in this experiment was only 2-3 kHz (i.e. 5-6 kHz from 3 kHz). The effects of greater or lesser distances should be examined. Lastly, the number of tones within the noise was limited to 10 and there was only one target tone. It remains unclear what effect the number of tones has on acquisition and should be tested.

In addition to manipulating the parameters of the stimuli, the parameters of the trials could also be manipulated. In the present study the stimulus was presented for 1s. To make the task simpler, the stimulus presentation could be increased. Also the time between stimulus and

presentation of the levers could be decreased in order to diminish task complexity by reducing the delay between stimulus and response. Lastly, the limited hold could be increased to allow rat more time to respond which may decrease task difficulty.

***Further expanding the understanding of the continuum of impulsivity.*** In terms of understanding how other variables affect impulsivity, other choice probes should be conducted. Gray et al. (2002) posit that the difficulty of the task is an underlying cause of the differential rates of false alarms between children diagnosed with ADHD and children who are not. So, for more experimental control this should be conducted in a lab using the same methodology as above but manipulating the ITI so that it is more variable than  $\pm 6s$  should provide a more difficult task (McGaughy and Sarter, 1995).

Another aspect to examine is the medium that the  $S^D$  is presented in. For this experiment, only auditory stimuli were used. To further explore this methodology, visual stimuli could be used. For such an experiment a rat should be trained to respond to a particular light as an  $S^D$  (e.g. green) in the presence of other lights (e.g. red and yellow). Also to test the idea that the noise is a distractor a study should use a tone as the  $S^D$  and use visual stimuli as the noise.

Lastly, to further test the validity of the SHR's lack of sustained attention the number of trials should be extended to see at what point the SHR reached 50% correct responding over a few trials. That is if the SHR is a model of ADHD this strain should be less likely to stay on task and should perform at 50% across multiple trials sooner than other strains.

***Understanding discrimination threshold.*** Because the rats could not discriminate between the two stimuli, the discrepancy of the two stimuli could be determined. One way to do this is to decrease the amplitude of the noise until the rat reaches the criterion set above. This will determine if the signal to noise ratio was too high. Another manipulation would be to move



the distance between the target tone and the noise band. Currently the target tone is presented to the rats at 3 kHz and the noise band is between 5 kHz and 6 kHz. So, in order to determine if there was any overlap on the critical bands the rat will be presented with the same 3 kHz tone but the frequency of the noise will be farther away from the target tone (e.g., 8-9 kHz, 10-11 kHz). Also the number of tones within the noise may be the cause of the lack of discrimination and as such the total tones should be decreased to determine the effect of the ratio of noise tones to the target tone. Currently there are ten tones within the noise band to the one target tone. So, the number of noise tones could be decreased (e.g. 5 tones) to determine if there is any effect of tone ratio.

### **Conclusion.**

Overall, rats could not learn the auditory discrimination task, but there were some strain differences. Providing a possible methodology to test the continuum of impulsivity as well as providing evidence for the SHR as an animal model of ADHD. With this methodology further research can be conducted in hopes of examining variables (e.g. amphetamines) that can aide in decreasing impulsive behaviors in those diagnosed with ADHD.

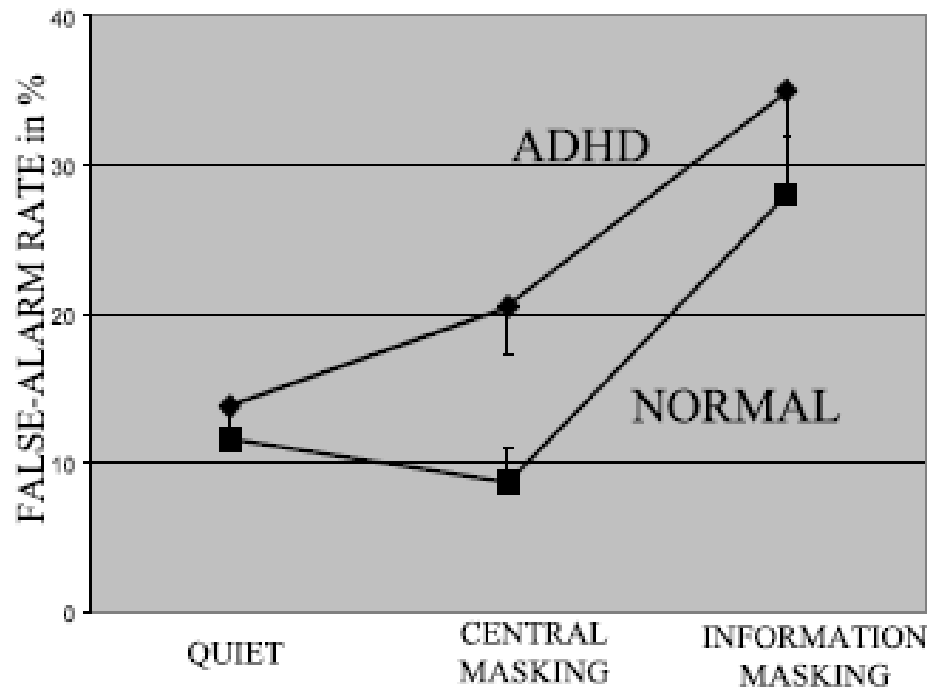

Figure 1. Graph taken from Grey et al. (2002) depicting the continuum of impulsivity measured by FA rates.

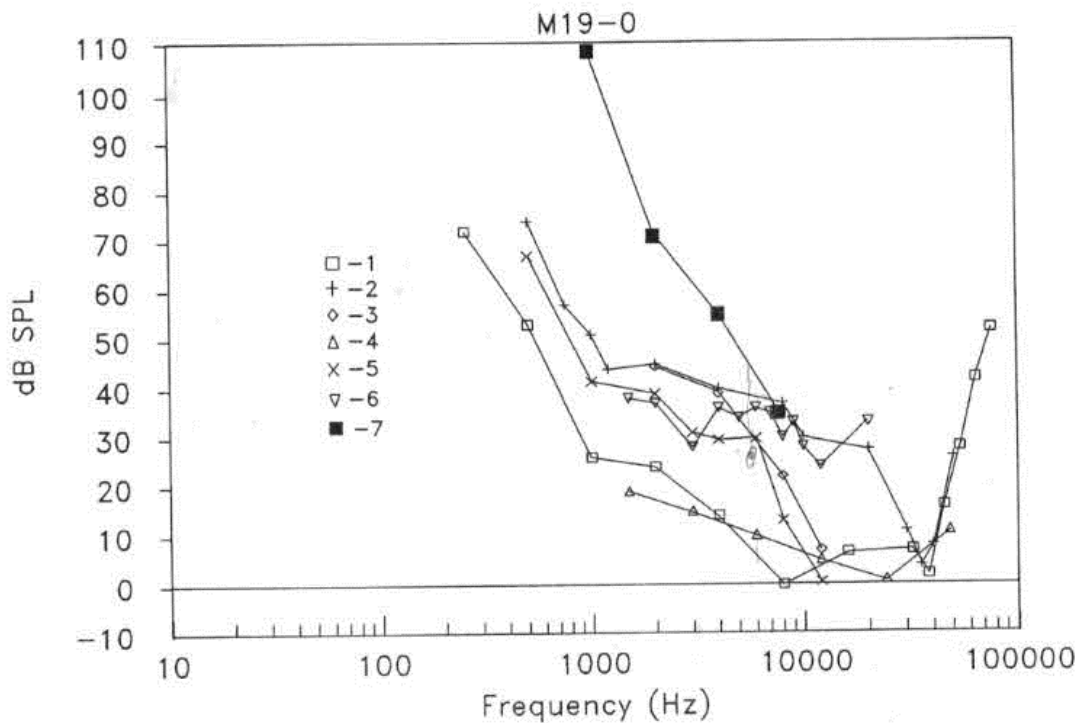
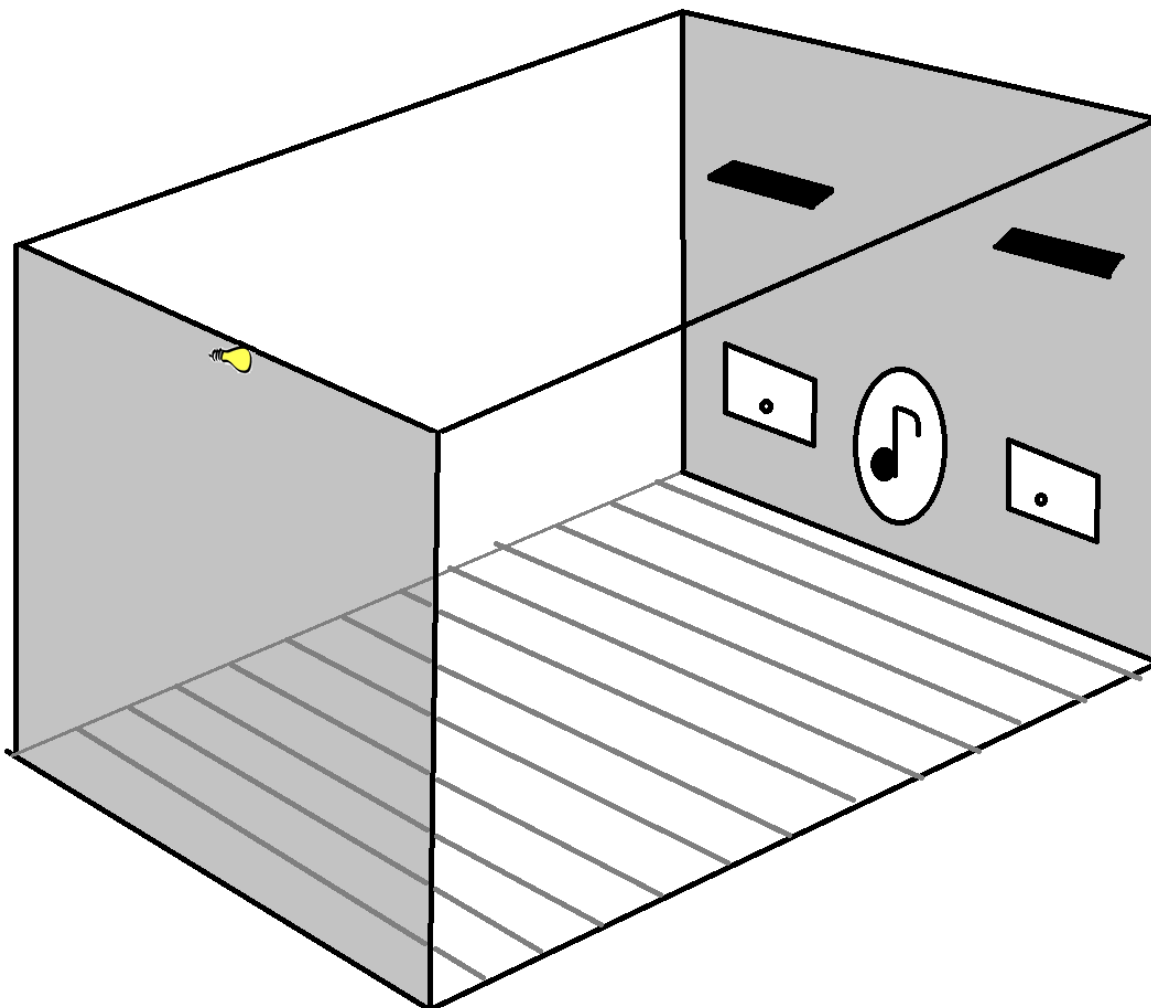

Figure 2. Graphic display of multiple studies on the rat audibility. Below is the key:

1. Kelly and Masterton (1980)
2. Gourivitch (1965) and Gourivitch and Hack (1966)
3. Jamison (1942)
4. Borg (1982)
5. Cowles and Pennington (1943)
6. Clack and Harris (1963)
7. Henry (1938)



*Figure 3.* The operant box set up. On the first grey wall the houselight was located at the top center facing the inside of the box. On the opposite grey wall there were 2 levers on the far left and on the far right, represented by black rectangles. Below each lever was a pellet receptacle, and in between that was the speaker represented by the circle with the musical note.

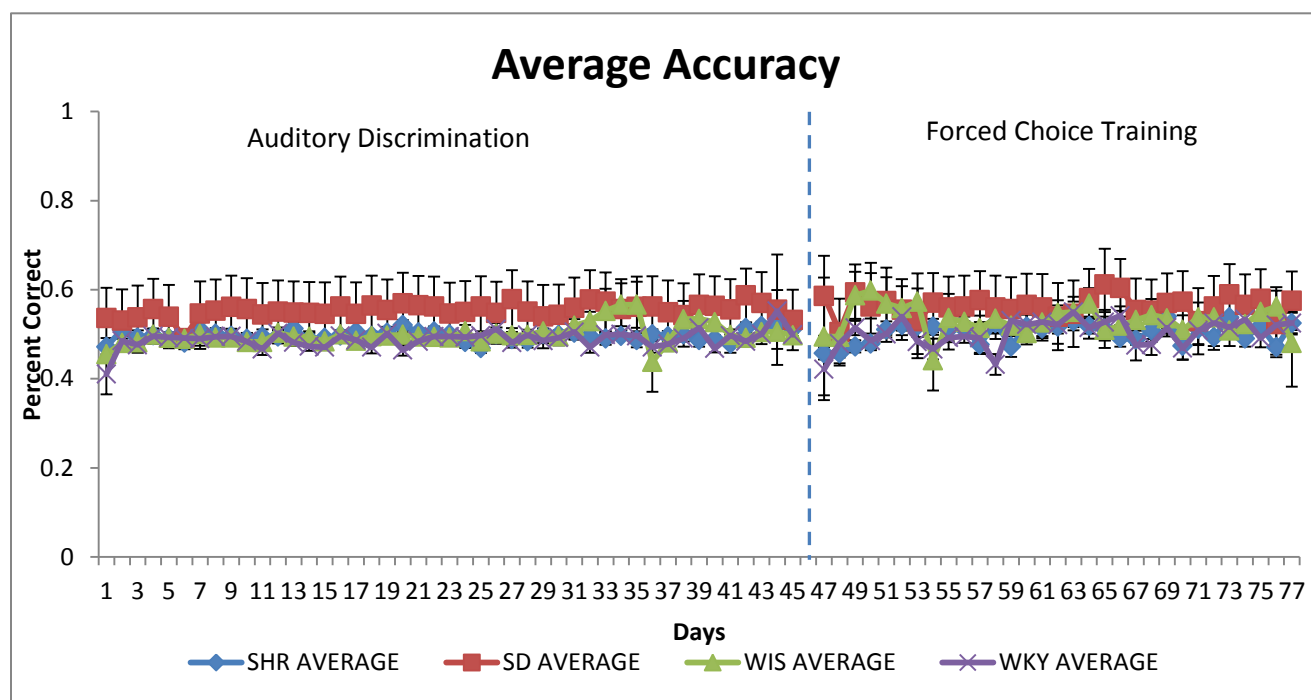

Figure 4. Average accuracy by strain. Error bars represent standard error of the mean.

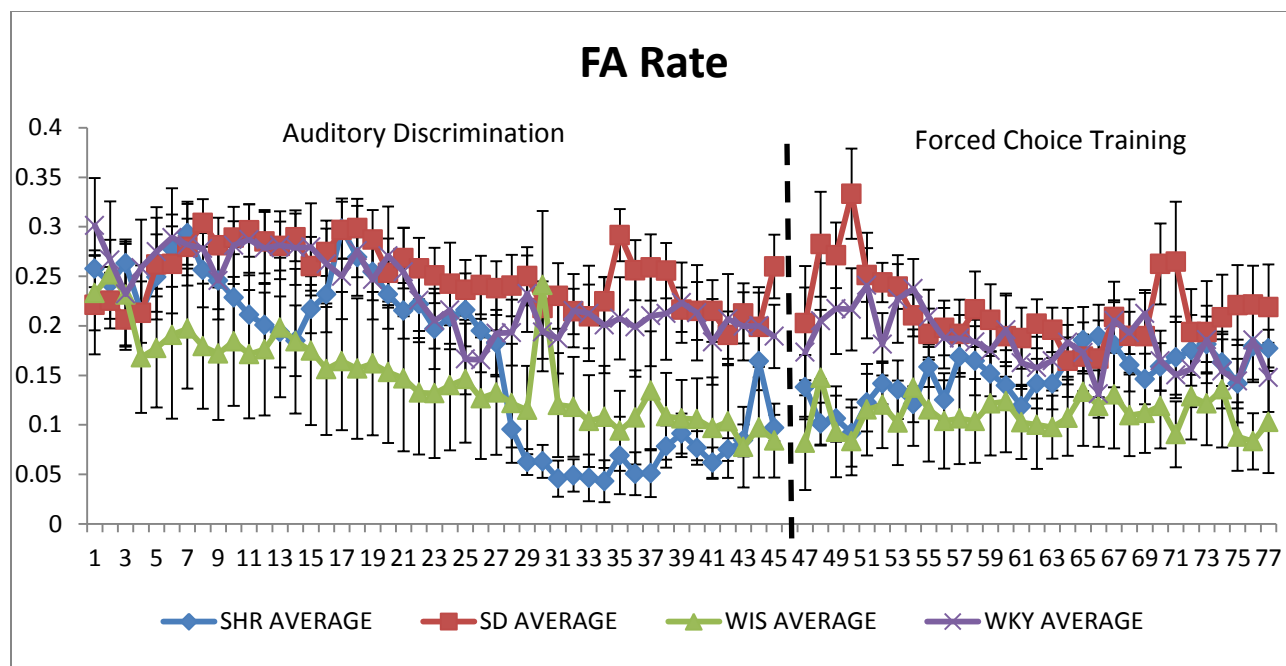
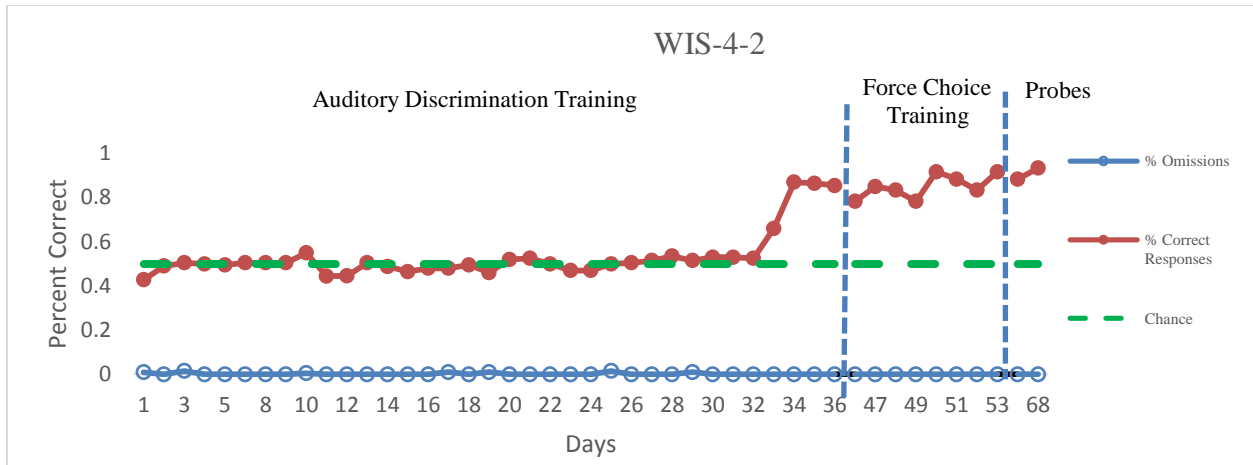

Figure 5. Average FA rates by strain. Error bars represent standard error of the mean.



*Figure 6.* Across three conditions WIS-4-2 learned an auditory discrimination task and maintained accurate responding across conditions.

## References

- Adriani, W., Caprioli, A., Granstrem, O., Crli, M., & Laviola, G. (2003). The spontaneously hypertensive rat as an animal model of ADHD: Evidence for impulsive and non-impulsive subpopulations. *Neuroscience and Behavioral Reviews*, 27, 639-651.
- Baum, W. M. (1973). The correlation-based law of effect. *Journal of Experimental Analysis of Behavior*, 20(1), 137-153.
- Baum, W. M. (1974). On two types of deviation from the matching law: Bias and undermatching. *Journal of Experimental Analysis of Behavior*, 22(1), 231-242.
- Borg, E. (1982) Noise-induced hearing loss in normotensive and spontaneously hypertensive rats. *Hearing Research*, 8, 117-130.
- Breier, J. I., Gray, L. C., Klaas, P., Fletcher, J. M., & Foorman, B. (2002). Dissociation of sensitivity and response bias in children with attention deficit/hyperactivity disorder during auditory masking. *Neuropsychology*, 16(1), 28-34.
- Buelow, M. T., & Suhr, J. A. (2009). Construct validity of the Iowa gambling task. *Neuropsychology Review*, 19(1), 102-114.
- Davison, M., & Nevin, J. A. (1999) Stimuli, reinforcers and behavior: An integration. *Journal of Experimental Analysis of Behavior*, 71(3), 439-482.
- Davison, M. C., & Tustin, R. D. (1978). The relation between the generalized matching law and signal-detection theory. *Journal of Experimental Analysis of Behavior*, 29(2), 331-336.
- Dinsmoor, J. A. (1985). The role of observing and attention in establishing stimulus control. *Journal of Experimental Analysis of Behavior*, 43(3), 365-381.
- Dinsmoor, J. A. (1995a). Stimulus control: Part I. *The Behavior Analyst*, 18(1), 51-68.
- Dinsmoor, J. A. (1995b). Stimulus control: Part II. *The Behavior Analyst*, 18(2), 253-269.



- Ferster, C. B. & Skinner, B. F. (1957). *Schedules of Reinforcement*. Acton, MA: Copley Publishing Group.
- Gourevitch, G. (1965). Auditory masking in the Rat. *The Journal of the Acoustical Society of America*, 37(3), 439-443.
- Gourevitch, G., Hack, M. H. (1966) Audibility in the rat. *Journal of Comparative and Physiological Psychology*, 62(2), 289-291.
- Green, D. M., & Swets, J. A. (1966). *Signal detection theory and psychophysics*. New York, NY: John Wiley & Sons, Inc.
- Green, L., & Myerson, J. (2013). How many impulsivities? A discounting perspective. *Journal of Experimental Analysis of Behavior*, 99(1), 3-13.
- Gray, L. C., Breirer, J. I., Foorman, B.R., & Fletcher, J. M., (2002) Continuum of impulsivity caused by auditory masking. *International Journal of Pediatric Otorhinolaryngology*, 66, 265-272.
- Harrison, J. M. (1988). Control of responding by sounds of different quality: An evolutionary analysis. *Journal of Experimental Analysis of Behavior*, 50(3), 521-539.
- Harrison, J. M. (1990) Simultaneous auditory discrimination. *Journal of Experimental Analysis of Behavior*, 54(1), 45-51.
- Herrnstein, R. J. (1970). On the law of effect. *Journal of Experimental Analysis of Behavior*, 13(2), 243-266.
- Hill, J. C., Herbst, K., & Sanabria, F. (2012) Characterizing operant hyperactivity in the spontaneously hypertensive rat. *Behavioral and Brain Functions*, 8, 1-15.

- Holt, D. D., Green, L., & Myerson, J. (2003). Is discounting impulsive?: evidence from temporal and probability discounting in gambling and non-gambling college students. *Behavioural Processes*, *64*(3), 355-367.
- Hunt, M. K., Hopko, D. R., Bare, R., Lejuez, C. W., & Robinson, E. V. (2005). Construct validity of the balloon analog risk task (BART) associations with psychopathy and impulsivity. *Assessment*, *12*(4), 416-428.
- Jenkins, H. M. & Harrison, R. H. (1960). Effect of discrimination training on auditory generalization. *Journal of Experimental Psychology*, *59*(4), 246-253.
- Jenkins, H. M. & Harrison, R. H. (1962). Generalization gradients of inhibition following auditory discrimination learning. *Journal of Experimental Analysis of Behavior*, *5*(4), 435-441.
- Johansen, E. B., Killeen, P. R., & Sagvolden, T. (2007) Behavioral variability, elimination of responses and delay-of-reinforcement gradient in SHR and WKY rats. *Behavioral and Brain Functions*, *3*, 1-11.
- McGaughy, J. & Sarter, M. (1995). Behavioral vigilance in rats: Task validation and effect of age, amphetamine, and benzodiazepine receptor ligands. *Psychopharmacology*, *117*, 340-357.
- Nevin, J. A. (1969). Signal detection and operant behavior: A review of David M. Green and John A. Swets' signal detection theory and psychophysics. *Journal of Experimental Analysis of Behavior*, *12*(3), 475-480.
- Prediger, R. D. S., Pamplona, F. A., Fernandes, D., & Takahashi, R. N. (2005) Caffeine improves spatial learning deficits in an animal model of attention deficit hyperactivity

- disorder (ADHD) – the spontaneously hypertensive rat (SHR). *International journal of Neuropsychopharmacology*, 8, 583-594.
- Sagvolden, T. (2000) Behavioral validation of the spontaneously hypertensive rat (SHR) as an animal model of attention-deficit/hyperactivity disorder (ADHD). *Neuroscience and Biobehavioral Reviews*, 24, 31-39.
- Sagvolden, T., Johansen, E. B., Wøien, G., Walaas, I., Storm-Mathisen, J. Bergersen, L. H., ...Faraone, S. V. (2009) The spontaneously hypertensive rat model of ADHD-the importance of selecting the appropriate reference strain. *Neuropharmacology*, 57(7-8), 619-626.
- Sanabria, F., & Killeen, P. R. (2008). Evidence for impulsivity in the spontaneously hypertensive rat drawn from complementary response-withholding tasks. *Behavioral and Brain Functions*, 4, 1-17.
- Terman, M. (1970) Discrimination of auditory intensities by rats. *Journal of Experimental Analysis of Behavior*, 13(2), 145-160.