

The Influence of Base Isolation to the Required Ductility of Soft Storey Buildings

Agim Seranaj¹, Mihail Garevski²

¹Department of Structural Mechanics, Civil Engineering Faculty, Tirana, Albania

²Institute of Earthquake Engineering and Engineering Seismology (IZIIS), Skopje, Macedonia

ABSTRACT

The Response Spectrum Analysis of the structures is based on the allowable ductility considered for that structure. In the case of a multi-degree-of-freedom buildings, the required ductility cannot be the same with the allowable ductility; furthermore, the required ductility values are different for different storey. In the case of first soft/weak storey building, the required ductility of this storey is much higher compared to allowable ductility and impossible to achieve. Nowadays there are many cases of existing reinforced concrete structures with the possibility of soft/weak storey. Even new structures are required to have open space at ground floor level as the owners want them for shops or garages usage.

This paper analyses the influence of base isolation to the required storey ductility of weak storey buildings. A five storey shear frame type structure is considered as the model. The elastic and elasto-plastic modelling of the structural elements and bilinear modelling of rubber isolators are used. Linear Response Spectrum analysis and Nonlinear Time History analysis are performed in order to determine the required storey ductility for the existing and new soft/weak storey buildings using the SAP2000 computer program.

The analysis results show the reduction of the required storey ductility due to the application of base isolation not only in new structures, but in existing structures too. This means that the base isolation technique is a good alternative to be applied in buildings with first soft/weak storey structure.

Keywords: *soft/weak storey, required ductility, base isolation*

INTRODUCTION

The seismic response of the structure can be obtained using response spectrum analysis, RSA or time history analyses, THA [1]. Response spectrum analysis is based on the seismic response spectrum which is considered for different values of the allowable ductility of the structure. For the single-degree-of-freedom systems the required ductility is the same as the allowable one, whereas for multi-degree-of-freedom systems these values are different (bigger or smaller).

Ductility depends on several factors. For building structures with storeys it is important to know the relation of the required ductility and the yield strength and stiffness of the storeys. To analyse this relationship we will use the concept of “weak” storey, which has a smaller yield strength compared to the required one, and also the concept of “soft” storey, which has a smaller stiffness compared to the required one.

Base isolation technique was developed as an attempt to reduce the effects on buildings and their structural elements during seismic events, and is becoming one of the most effective

methods for a wide range of problems of structures under the seismic action. [2] [3]. In recent decades, based isolation has become one of the most accepted techniques for seismic protection of buildings [4].

In order to study the influence of seismic isolation to the required ductility of a soft storey building, we will consider a five storey building with the first soft/weak storey to be isolated. These buildings can be existing or new structures, thus we will analyze the application of base isolation in both cases. The elastomeric isolation system is used. Mostly they are characterized by high vertical stiffness and low horizontal stiffness [5] [6]. The analysis performed in linear and nonlinear using elastic and elasto-plastic modelling of the structural elements allow us to determine the required ductility and make the comparison with the allowable ductility for different situations of structure. Linear Response Spectrum analysis and Nonlinear Time History analysis are performed in order to determine the required storey ductility using the SAP2000 computer program [7].

The required ductility of soft first storey of the existing structures can be very high and impossible to achieve. Applying base isolation on these buildings can reduce the required ductility to the desired value [8]. Based on the code, in case of base isolation of new buildings, the structure is designed to behave almost within the elastic range with the allowable ductility $\mu_a=1$. If this new structure tends to be soft/weak first storey, the base isolation is shown to be a good alternative to solve the problem.

ALLOWABLE AND REQUIRED DUCTILITY

Based on the response spectrum analysis, the design yield strength is determined, as a function of the allowable ductility by the following expression:

$$f_y = A_y \cdot m$$

where m is the mass of system and A_y is the pseudo-acceleration obtained from response spectrum of the considered allowable ductility.

From the response spectrum analysis, the yield strength (f_y) and yield deformation (Δ_y) are determined using the response spectrum for the corresponding values of the ductility μ_a .

From the time history analysis, based on the elasto-plastic behaviour diagram, and parameters resulting from the response spectrum analysis (k, f_y, Δ_y), we will determine the maximum deformation Δ_m of the structure. The required ductility is determined by the ratio between the maximum deformation and the yield deformation:

$$\mu_r = \frac{\Delta_m}{\Delta_y}$$

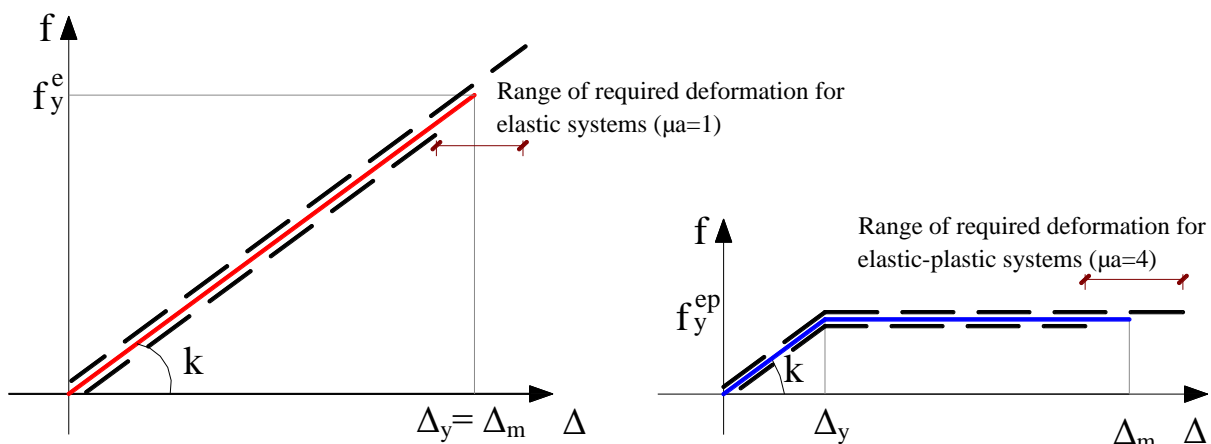

Figure 1: Maximum allowable and required deformation for two systems, $\mu_a=1$ and $\mu_a=4$

Question: Does the required ductility (μ_r) has the same value as the allowable ductility (μ_a)? The response of elasto-plastic elements requires a certain level of the deformations. The required deformation can be bigger or smaller than the structure's deformation capacity [9]. This is schematically shown in Figure 1, for two different cases of the structure; the first with allowable ductility $\mu_a = 1$ and the second with $\mu_a = 4$.

SEISMIC RESPONSE OF MULTI-STOREY BUILDING AND STOREY DUCTILITY

Different models are created to study the seismic response of fixed base or base isolated multi-storey buildings with different storey yield strength and storey stiffness distribution, or with different values of allowable ductility. The TYPE 1 represent the normal structure with uniform storey stiffness. The TYPE 2 represent the soft/weak first storey structure, which is obtained by structure TYPE 1, multiplying the stiffness of storey two to five by 4. TYPE 2a BI and TYPE 2b BI represent the application of base isolation to the structure TYPE 2 in case of new and existing buildings. These models are schematically shown below:

Base situation	Types of structure considered	Analysed cases for each Type
Fixed base structures	TYPE 1 (normal structure) $k_1 \times 1$ and $k_{2-5} \times 1$	$\mu_a = 1$
Fixed base structures	TYPE 2 (soft/weak first storey) $k_1 \times 1$ and $k_{2-5} \times 4$	$\mu_a = 1$ and $\mu_a = 4$
Base isolation of new buildings	TYPE 2a BI $k_1 \times 1$ and $k_{2-5} \times 4$	$\mu_a = 1$
Base isolation of existing buildings	TYPE 2b BI $k_1 \times 1$ and $k_{2-5} \times 4$	$\mu_a = 4$

The shear frame 5 storey structure is considered to analyse as shown in Figure 2:

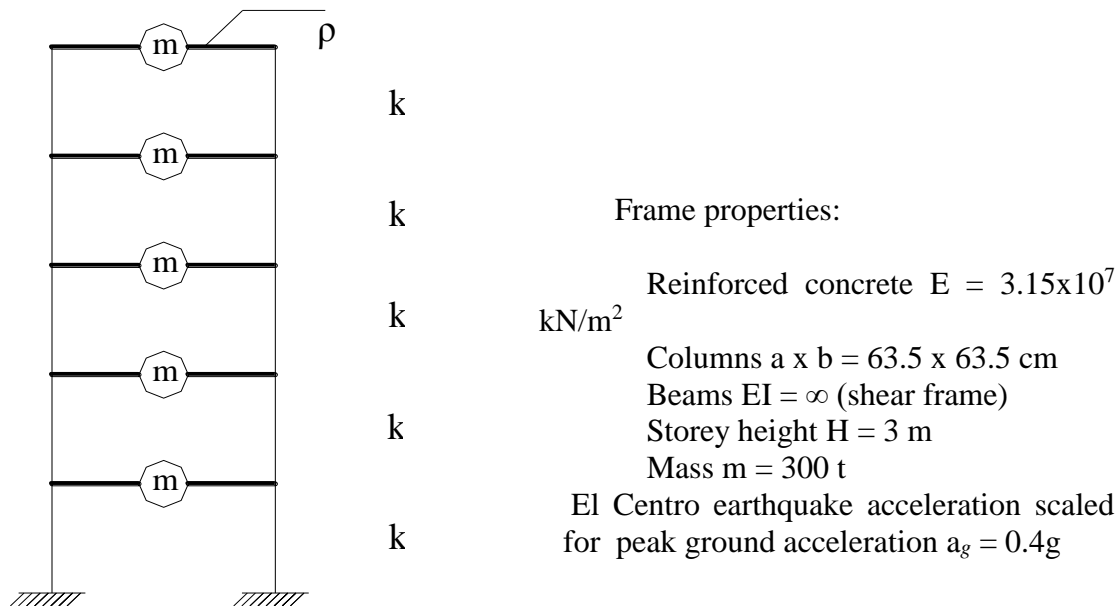

Figure 2: Five-story shear frame of linear elastic model

First we conduct the response spectrum analysis using SAP2000 computer software, in elastic range ($\mu = 1$) with $\eta = 5\%$ damping. From this analysis we obtain the results given in Table 1 below. Since these results represent the yield phase, we note them with the index “y” (yield).

Table 1: Results of linear elastic response of a 5 – storey structure

Storey	Displacement U_{yj} (cm)	Deformation Δ_{yj} (cm)	Shear force $f_{y,j}^e$ (kN)	Storey stiffness k_j (kN/m)
5	11.07	1.82	1149	63132
4	9.25	2.24	1953	57185
3	7.01	2.43	2504	103045
2	4.58	2.42	2937	121364
1	2.16	2.16	3221	149120

where U_{yj} is the yield displacement of storey “j”; $\Delta_{yj} = U_{yj} - U_{y(j-1)}$ is the yield deformation of storey “j”; $f_{y,j}^e$ is the shear force of storey “j”, which in case of elasto-plastic systems, represents the yield strength; and k_j is the stiffness of storey “j”, $k_j = f_{y,j}^e / \Delta_{yj}$. For the time history analysis we will consider a new model of the shear frame in order to perform the analysis in the elasto-plastic range ($\mu > 1$) besides the elastic one ($\mu = 1$). Figure 3 shows this model, where the columns are replaced with elements with infinite stiffness $EI = \infty$ while the elastic parameters are represented by the nonlinear elements NLIN_j, the characteristics of which are the same of the columns they replace. Nonlinear elements NLIN_j are modelled with stiffness k_j and yield strength f_{yj}^{ep} . Figure 4 shows the elasto-plastic diagram of the nonlinear elements NLIN_j. It is obvious that in case of elastic systems $f_{yj}^{ep} = f_{yj}^e$ (because $\mu = 1$), while in case of elasto-plastic systems f_{yj}^{ep} is a function of the allowable ductility.

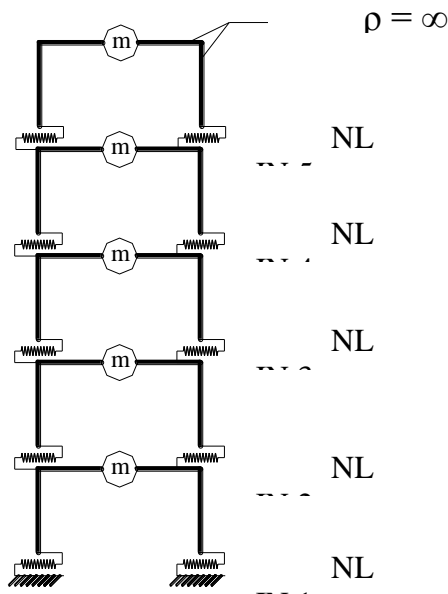

Figure 3: Shear frame of elasto-plastic (nonlinear) model

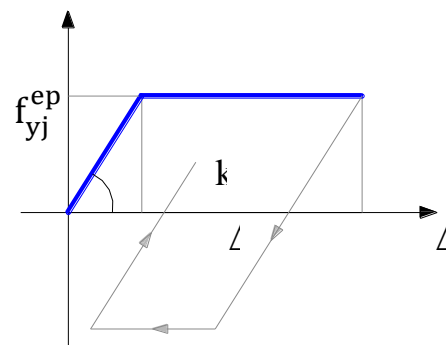

Figure 4: Elasto-plastic diagram between shear force and storey deformation

Two analysis will be conducted: the response spectrum analysis (RSA) and time history analysis (THA). These analysis will be perform for two different allowable ductility levels: allowable ductility $\mu_a = 1$ (elastic system) and allowable ductility $\mu_a = 4$ (elasto-plastic system).

First, the response spectrum analysis is performed using El Centro earthquake response spectrum with 5% damping for the allowable value of ductility.

With the response spectrum analysis results, the nonlinear elements NLIN_j are modelled in order to continue with the time history analysis, using the same earthquake acceleration with 5% damping. With the nonlinear analysis results we determine the maximum storey displacements U_{mj} , which then are used to calculate the maximum storey deformations (by the difference of maximum storey displacements):

$$\Delta_{mj} = U_{mj} - U_{m(j-1)}$$

Knowing the elastic deformations of the storeys Δ_{yj} and their maximum required deformations, it is possible to calculate their required ductility $\mu_{rj} = \frac{\Delta_{mj}}{\Delta_{yj}}$

MULTI-STOREY BUILDINGS WITH WEAK AND SOFT STOREY

There are reasons the engineers are facing to the situation of soft/weak storey buildings. Mostly, it happens because of architectural requirements to have an open space at ground floor level. To illustrate this relation, let us consider a different structure, called TYPE 2, with soft/weak first storey. Practically, weak storey buildings are also soft storey buildings because this storey will be more flexible than the others. This happens because the strength and the stiffness are inter-related.

The parameters of structure TYPE 2, are performed from above structure, multiplying the stiffness of second to fifth storeys by 4, keeping the same value of the first storey stiffness. By this, the TYPE 2 structure becomes with soft first storey. Using the elasto-plastic model, two types of analyses are conducted: response spectrum analysis and time history analysis, with two different levels of the allowable ductility $\mu_a = 1$ and $\mu_a = 4$.

First the response spectrum analysis is conducted, which gives us the results of the yield strength of the second to fifth storeys.

Then we perform the time history analysis, taking results of the maximum required displacement of the storeys, U_{mj} , to calculate the maximum required deformations, Δ_{mj} , and the required storey ductility μ_{rj} .

The analysis results of the parameters of interest are given in the Tables 2 and 3:

Table 2: Analyses results of structure TYPE 2, with $\mu_a = 1$

Analysis type		Response spectrum analysis (L)			Time – history analysis (NL)		
St orey	k_j	U_{yj} (cm)	Δ_{yj} (cm)	f_{yj}^{ep} (kN)	U_{mj} (cm)	Δ_{mj} (cm)	μ_{rj}
5	25 2528	8.2 4	0.6 6	166 5	5.71	0.35	0 .53
4	34 8740	7.5 8	0.9 2	319 6	5.36	0.47	0 .51
3	41 2180	6.6 6	1.1 0	454 2	4.89	0.53	0 .48
2	48 5456	5.5 6	1.1 6	566 4	4.36	0.53	0 .46
1	14 9120	2.1	2.1	312 6	3.83	3.83	1 .82

Table 3: Analyses results of structure TYPE 2, with $\mu_a = 4$

Analysis type		Response spectrum analysis (L)			Time – history analysis (NL)		
St orey	k_j	U_{yj} (cm)	Δ_{yj} (cm)	f_{yj}^{ep} (kN)	U_{mj} (cm)	Δ_{mj} (cm)	μ_{rj}
5	25 2528	2.0 6	0.1 6	416	8.05	0.04	0 .25
4	34 8740	1.9 0	0.2 3	799	8.01	0.06	0 .26
3	41 2180	1.6 7	0.2 8	113 5	7.95	0.10	0 .36
2	48 5456	1.3 9	0.2 9	141 6	7.85	0.11	0 .38
1	14 9120	1.1 0	1.1 0	781	7.74	7.74	1 4.6

From the results of Tables 2 and 3 it is obvious that TYPE 2 model, represent the structure with soft and weak first storey. The required storey ductility is shown in shown graphically in Figures 5, for the two analyses cases with allowable ductility $\mu_a = 1$ and $\mu_a = 4$:

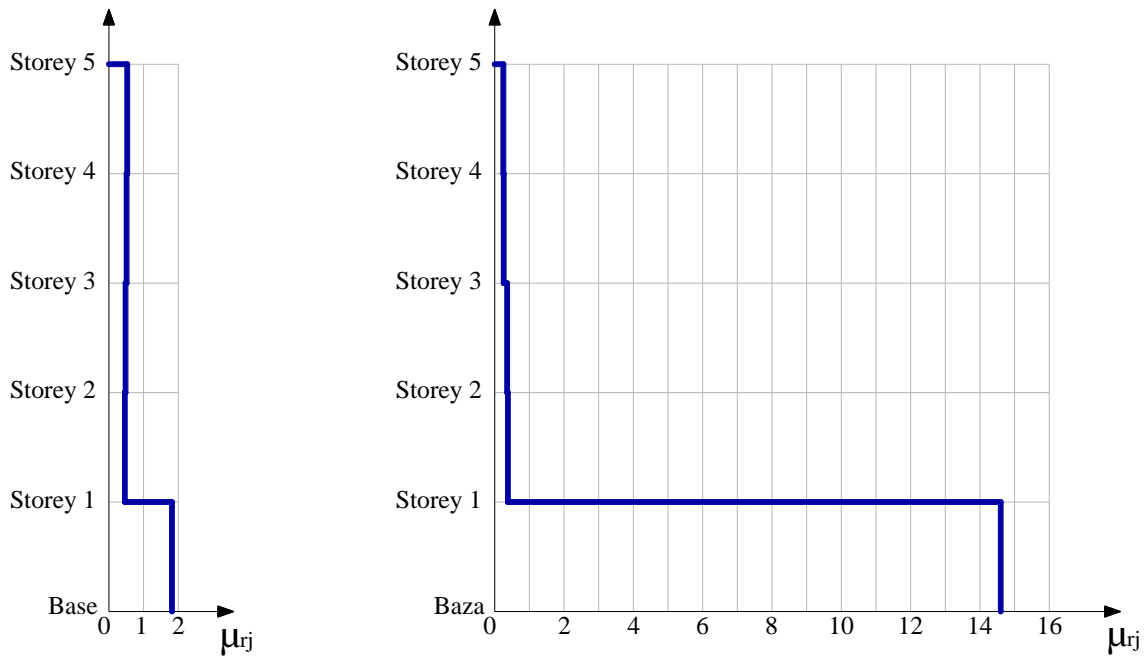

Figure 5. Required story ductility of TYPE 2 structure: a) for $\mu_a=1$, b) for $\mu_a=4$

So, the required ductility of the first storey $\mu_{r1} = 14.6$ is much bigger than the allowable one $\mu_a=4$ and practically impossible to be possessed by conventional structures. Thus, this structure cannot resist the design seismic action.

THE INFLUENCE OF SEISMIC ISOLATION TO THE REQUIRED DUCTILITY

In order to study the influence of seismic isolation to the required ductility of a soft storey building, we will consider the previous structure (TYPE 2), but with a base isolation.

Isolators are considered bilinear and their characteristics are calculated for the given quantities $W= 350$ kN, $T=2.3$ s, $D=0.15$ m, $\beta= 5\%$ and $r=0.1$, the isolators characteristics are:

$$K_{eff} = 5591 \text{ kN/m}; K_1 = 42256 \text{ kN/m}; Q_y = 228 \text{ kN}; u_y = Q_y/K_1 = 0.539 \text{ cm}.$$

First the response spectrum analysis is performed using SAP2000 computer software, for the elastic phase ($\mu = 1$) with $\eta = 15\%$ damping.

For the time history analysis, in order to perform the elasto-plastic nonlinear analysis besides the elastic one, we will use the model with nonlinear elements. Schematically this model is shown in Figure 6.

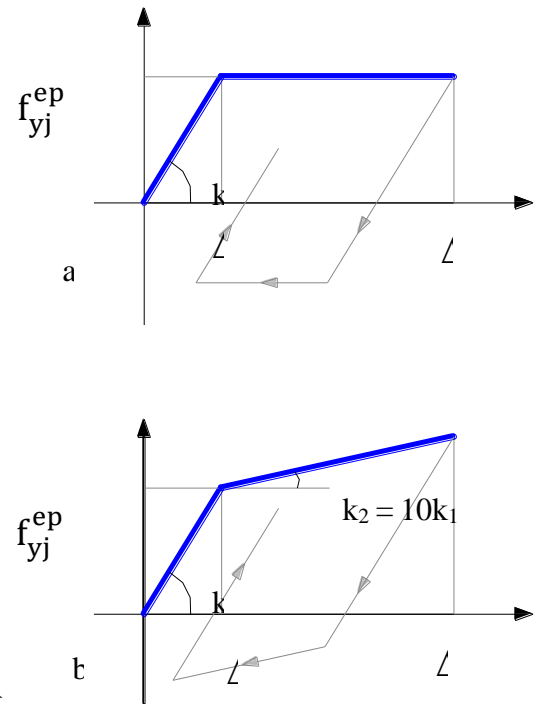
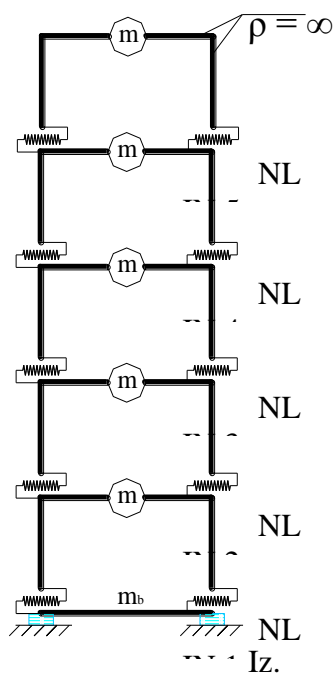

Figure 6: Elasto-plastic (nonlinear) model of base isolated frame

Figure 7: Nonlinear diagram of elements: a) Elasto-plastic diagram between shear force and storey deformation, b) Isolators bilinear diagram

This model represents the replacement of the columns with elements with infinite stiffness $EI = \infty$ and with elastic characteristics of nonlinear elements, $NLIN_j$, which are the same as the characteristics of the column replaced. Practically, the nonlinear elements $NLIN_j$ are modelled with stiffness k_j and yield strength f_{yj}^{ep} . The elasto-plastic diagram of the nonlinear elements, $NLIN_j$, is shown in Figure 7a while the bilinear diagram of the isolators is shown in Figure 7b.

Two types of analyses are conducted with the elasto-plastic model: the response spectrum analysis (RSA) and time history analysis (THA). First, the response spectrum analysis is performed using the El Centro earthquake response spectrum with $\eta = 15\%$ damping (to consider the damping level of the isolators). With the results of this analysis, the characteristics of the nonlinear elements $NLIN_j$ are modelled, further to be used for the time history analysis. Since isolated structures response is within the elastic range, the damping level of the structures is low, thus the nonlinear elements $NLIN_j$ are considered with $\eta = 2\%$ elastic damping. To study the seismic isolation effect on different structures we will analyze the base isolation of new buildings and the base isolation of existing ones.

a) Base isolation of new buildings

Since base isolated structures are designed to behave almost within the elastic range, the allowable ductility for the analyses is accepted level $\mu_a = 1$.

The third model, called structure TYPE 2a BI, represents the seismic isolation of structure TYPE 2 with allowable ductility $\mu_a = 1$. Since the yield strength of this type of structure is accepted to be different from the results of response spectrum analysis, the storeys yield deformation will be calculated by the expression $\Delta_{yj} = f_{yj}/k_j$ for all storeys (as shown in Table 4). For this case, only time history analysis is performed in order to estimate the required deformations and the required ductility of each storey (Δ_{mj} and μ_{rj}). The analyses results of structure TYPE 2a BI, are given in Tables 4.

Table 4: Analysis results of structure TYPE 2a BI, with $\mu_a = 1$

Analysis type		Response spectrum analysis (L)			Time – history analysis (NL)		
St orey	k_j	U_{yj} (cm)	Δ_{yj} (cm)	f_{yj}^{ep} (kN)	U_{mj} (cm)	Δ_{mj} (cm)	μ_{rj}
5	25	20.	0.1	223	14.8	0.1	0
	2528	78	1		9		
4	34	20.	0.1	445	14.7	0.1	0
	8740	67	4		9		
3	41	20.	0.1	655	14.6	0.1	0
	2180	53	6		8		
2	48	20.	0.1	874	14.5	0.1	0
	5456	37	8		5		
1	16	20.	0.6	107	14.4	0.4	0
	2571	19	6		9		

From the results of the analysis of structure TYPE 2a BI it is concluded that base isolation of the structure with soft (and weak) first storey is very effective to the reduction of storey required ductility

b) Base isolation of existing buildings

If we apply the seismic isolation on existing structures (designed and built in a previous period of time) with soft and weak first storey, we can conclude that the required storey ductility is obviously reduced.

To illustrate the effect of base isolation we consider the five-storey shear frame analyzed before, structure TYPE 2. Supposing that the existing buildings are designed with allowable ductility $\mu_a = 4$. The Isolated structure is called TYPE 2b BI. The characteristics of isolators are the same as those used for structure TYPE 2a BI. The results of the time history analysis are given in Tables 5:

Table 5: Analysis results of structure TYPE 2b BI , with $\mu_a = 4$

Analysis type		Response spectrum analysis (L)			Time – history analysis (NL)		
St orey	k_j	U_{yj} (cm)	Δ_{yj} (cm)	f_{yj}^{ep} (kN)	U_{mj} (cm)	Δ_{mj} (cm)	μ_{rj}
5	25	2.0	0.1	416	14.9	0.0	0
	2528	6	6		1	9	.56
4	34	1.9	0.2	799	14.8	0.1	0
	8740	0	3		2	3	.57
3	41	1.6	0.2	113	14.6	0.1	0
	2180	7	8		5	9	4
2	48	1.3	0.2	141	14.5	0.1	0
	5456	9	9		6	5	5
1	14	1.1	1.1	781	14.4	0.5	0
	9120		0		0	2	.98

To better understand the change of the required ductility values, Figure 8 shows the required ductility of isolated and non isolated structures, for both cases, base isolation of new structures and base isolation of existing structures.

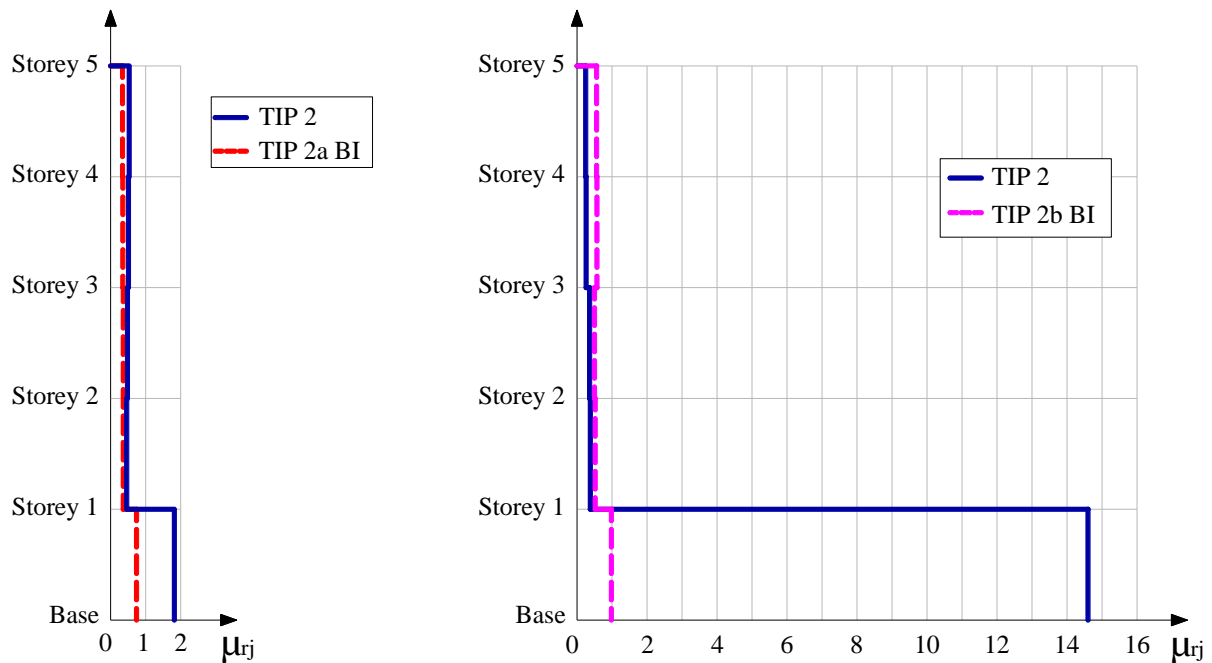

Figure 8: a) The required ductility for each storey of fixed base (TYPE 2) and base isolated (TYPE 2a BI) of new structures designed with allowable ductility $\mu_a = 1$.

b) The required ductility for each storey of fixed base (TYPE 2) and base isolated (TYPE 2b BI) of existing buildings) designed with allowable ductility $\mu_a = 4$

Comparing the results of the required deformation of structural elements of the first storeys, we conclude that for the nonisolated structures the deformation demand is higher, while for isolated structures, structural elements almost does not have deformations, because these deformations are mostly developed on the isolation system.

Seismic isolation of existing buildings with soft first storey (and weak storey) reduces the required ductility of the first storey from $\mu_{r1} = 14.6$ as in the case of structure TYPE 2, to $\mu_{r1} = 0.98$ in the structure TYPE 2b BI. So, with seismic isolation of existing soft storey structures, it is provided that the structure behaves in the elastic range (even the soft storey).

Seismic isolation is used very effectively to improve the required ductility of the structure if it was designed with higher value of the required ductility which in practice is impossible to achieve.

The nonlinear analyses of isolated structures, TYPE 2a BI and TYPE 2b BI, are conducted using the yield strength of the existing storeys. The fact that the required ductility of isolated structures is less than 1, shows that the structure has sufficient strength (because its elastic strength capacity can be higher than needed).

CONCLUSION

In structures that represent the soft storey phenomenon, the seismic isolation manages to improve the structure response and is able to eliminate the defect.

For new base isolated structures, it is possible to design them to behave close to elastic range. So the isolation of buildings calculated in linear phase ($\mu_a = 1$) improves the first storey to develop no plastic deformations.

The benefit of seismic isolation in the reduction of yield strength (shear force) is well known. This study shows another benefit, the reduction of storey ductility of building structures.

If we apply the seismic isolation on existing structures (designed and built in a previous period of time) with soft and weak first storey, it will state that storeys ductility demand will be significantly improved.

Through seismic isolation of existing buildings with soft storey (and weak storey) with high required ductility it is possible to reduce considerably the value of this ductility. By using the seismic isolation, even the soft storey response is within the elastic range.

Seismic isolation is used very effectively to improve the ductility of the structure if it is designed with higher value ductility demand which in practice is impossible to achieve.

REFERENCES

- [1] Chopra, A.K., "Dynamics of Structures: Theory and Application to Earthquake Engineering", 2nd Ed, Pearson Prentice Hall, Upper Saddle River, New Jersey, 2007
- [2] Skinner, R.I., Robinson, W.H., McVerry, G.H., "An Introduction to Seismic Isolation", John Wiley & Sons Ltd., New York, 1993.
- [3] Naeim, F., Kelly, J.M., "Design of Seismic Isolated Structures", John Wiley & Sons, New York, 1999.
- [4] Higashino, M., Okamoto, S., "Response Control and Seismic Isolation of Buildings", Taylor & Francis, New York, 2006
- [5] Kelly, J.M., "Earthquake Resistant Design with Rubber", Springer-Verlag London Limited, 1997.
- [6] Kelly, E, Trevor. "Base Isolation of Structures", Holmes, Consulting Group Ltd, 2001.
- [7] SAP2000®, Integrated Finite Element Analysis and Design of Structures, analysis Reference, Vol. 1&2, Computer and Structures, Inc, Berkeley, California, USA, 2000
- [8] Seranaj, A., "Dynamic Response and Seismic Analysis of Base Isolated Buildings", Monograph, Scholar's Press, www.omniscryptum.com, Germany, 2016
- [9] Seranaj, A., "Reagimi Dinamik dhe Analiza Sizmike e Strukturave të Izoluara në Bazë me Izolator Gome me Fibra", Disertacion Doktorature, Tiranë, Albania, 2015