



Durham E-Theses

An investigation into how Chinese college students make sense of films and TV series from an intercultural perspective: Implications for English language teaching

YANG, HUI

How to cite:

YANG, HUI (2011) *An investigation into how Chinese college students make sense of films and TV series from an intercultural perspective: Implications for English language teaching*, Durham theses, Durham University. Available at Durham E-Theses Online: <http://etheses.dur.ac.uk/779/>

Use policy

The full-text may be used and/or reproduced, and given to third parties in any format or medium, without prior permission or charge, for personal research or study, educational, or not-for-profit purposes provided that:

- a full bibliographic reference is made to the original source
- a [link](#) is made to the metadata record in Durham E-Theses
- the full-text is not changed in any way

The full-text must not be sold in any format or medium without the formal permission of the copyright holders.

Please consult the [full Durham E-Theses policy](#) for further details.

Academic Support Office, Durham University, University Office, Old Elvet, Durham DH1 3HP
e-mail: e-theses.admin@dur.ac.uk Tel: +44 0191 334 6107
<http://etheses.dur.ac.uk>

**An Investigation into
How Chinese College Students Make Sense of Films and TV Series from an
Intercultural Perspective:
Implications for English Language Teaching**

(Linda) Hui Yang

A Thesis submitted for the degree
of
Doctor of Philosophy
in
Education



School of Education

February 2011

For my parents and my husband.

献给我的父母和我的丈夫。

Abstract

Title: An Investigation into How Chinese College Students Make Sense of Films and TV Series from an Intercultural Perspective: Implications for English Language Teaching

Author: (Linda) Hui Yang

Abstract:

This study investigates how Chinese College Students (CCSs) make sense of foreign films and TV series from an intercultural perspective, and then explores the theoretical and pedagogical implications of the findings on the use of foreign films and TV series in English language teaching, particularly for developing students' intercultural communicative competence.

The study employed a questionnaire survey and multiple-stage semi-structured interviews. Research subjects were second-year or above CCSs with students from 15 Beijing universities participating.

The empirical findings suggest that:

- In the Chinese context, foreign films and TV series are the main resource Chinese college students use, and the one they prefer to use, to learn about the U.K. and the U.S.A.
- Making sense of foreign films and TV series is a highly complex and dynamic process which is culturally specific. Chinese college students' undertake sense-making activities which fall into five main categories: 1) comprehending the plot; 2) compare: identifying differences; 3) compare: identifying similarities; 4) re-contextualizing; and 5) perceiving as realistic. These sense-making activities tend to be intertwined and occur on various levels.
- These sense-making activities affect Chinese college students' understanding of and attitudes to foreign people and culture, as well as to local people and culture.

A Foreign Media Sense-Making (FMSM) model is developed based on the sense-making activities identified and the variables which influence them. This model provides a theoretical framework suggesting how foreign films and TV series can be used to develop students' intercultural communicative competence in the English language teaching classroom, and an intercultural approach to the use of foreign films and TV series in ELT is suggested.

The findings give valuable insights and have practical implications for those interested in using foreign films and TV series in ELT. The FMSM model provides a conceptual framework and useful resource for the development of future research and teaching programmes.

Table of Contents

Abstract	v
Table of Contents	vii
Acknowledgements	xi
Declaration	xii
Statement of Copyright	xii
Chapter One: Introduction	1
Chapter Two: Research Context	6
2.1 Education Systems in China	6
2.1.1 School Education System	7
2.1.2 English Language Education in the School Education System.....	7
2.2 Media Censorship and Piracy in China	9
2.2.1 Media Censorship in China.....	10
2.2.2 Media Piracy in China	11
2.3 Chapter Summary.....	12
Chapter Three: Literature Review	13
3.1 Mass Media Communication & Effects.....	13
3.1.1 Mass Communication Models.....	14
3.1.2 Media Effects.....	19
3.2 Intercultural Communicative Competence in ELT.....	25
3.3 Films & TV Series in ELT	32
3.3.1 Films in ELT: Non-Chinese Context	32
3.3.2 TV Series in ELT: Non-Chinese Context	41
3.3.3 Films in ELT: Chinese Context.....	41
3.3.4 Summary	51
3.4 Conclusion.....	54
Chapter Four: Empirical Study, Research Questions and Methodology	56
4.1 Research Questions	56
4.2 Research Methodology.....	58
4.2.1 Questionnaire.....	58
4.2.2 Semi-structured Interview	61
4.3 The Pilot Study	65
4.3.1 Pilot Questionnaire	66

4.3.2 Pilot Semi-structured Interview	67
4.3.3 Reflections on the Pilot Study	67
4.4 Ethics Issues	68
4.5. Fieldwork	71
4.5.1 Sampling	71
4.5.2 Data Collection	72
4.6 Validity and Reliability	74
4.7 Data Analysis Techniques	79
4.7.1 Grounded Theory	80
4.7.2 Bilingual Coding Techniques	80
4.7.3 Bilingual Data Presentation	83
4.8 Valuable Extra	84
Chapter Five: Data Analysis – Research Questions 1 & 2.....	85
5.1 Research Question 1	86
5.2 Research Question 2	90
Chapter Six: Data Analysis – Research Question 3	95
6.1 Comprehending the Plot	95
6.2 Compare: Identifying Differences	106
6.2.1 Compare: Identifying Differences: Fictional Character(s) and Self/Significant Individual.....	106
6.2.2 Compare: Identifying Differences: Fictional Character(s) and Chinese People in General.....	109
6.2.3 Compare: Identifying Differences: Generalised Group of People Represented by Fictional Character(s) and Chinese People in General.....	114
6.2.4 Summary.....	122
6.3 Compare: Identifying Similarities.....	123
6.3.1 Compare: Identifying Similarities: Fictional Character(s) & Self/Significant Individual.....	123
6.3.2 Compare: Identifying Similarities: Fictional Character(s) and Chinese People in General.....	136
6.3.3 Compare: Identifying Similarities: Generalised Group of People Represented by Fictional Character(s) and Chinese People in General.....	143
6.3.4 Summary.....	148
6.4 Re-contextualizing.....	149
6.4.1 Re-contextualizing Fictional Character(s) in a Personal Context	149
6.4.2 Re-contextualizing Fictional Character(s) in the Chinese Context	151

6.4.3 Re-contextualizing Self in the Fictional Context	157
6.4.4 Re-contextualizing Chinese People in General in the Fictional Context	161
6.4.5 Summary	164
6.5 Perceiving as Realistic.....	165
6.5.1 Mirror of Reality	166
6.5.2 Perceiving as Realistic: General to Specific	173
6.5.3 Summary	184
6.6 Chapter Summary.....	186
Chapter Seven: Data Analysis – Research Question 4.....	187
7.1. Effect on Understanding of and Attitudes to Self/Significant Individuals	188
7.2 Effect on Understanding of and Attitudes to Groups of Chinese People in General	189
7.3 Effect on Understanding of and Attitudes to Generalized People Represented by Fictional Character(s)	190
7. 4 Reinforcing/Challenging Philosophy of Life	195
7. 5 Summary	196
Chapter Eight: Discussion	198
8.1 A Foreign Media Sense-Making Model.....	199
8.1.1 Mass Media Communication Models	199
8.1.2 Structure of Model: Foreign Media Sense-Making.....	201
8.1.3 Viewer Variables.....	202
8.1.4 Environmental Variables	203
8.1.5 Sense-Making Activities	204
8.1.6 Effects	206
8.1.7 Implications of the Model	207
8.2 Current Use of Foreign Films and TV Series in ELT in China.....	208
8.3 Critical Review of Literature Based on Findings	214
8.4 Using Foreign Films in ELT: An Intercultural Approach.....	219
8.4.1 Intercultural Communicative Competence	219
8.4.2 Teaching Material	221
8.4.3 Role of the Teacher.....	221
8.4.4 Learning Activities.....	222
8.4.5 Film/Clip Selection Criteria.....	223
8.4.6 Prompt Questions: Pre-viewing and Post-viewing	225
8.4.7 Application in the Chinese Context	226
8.4.8 Application in the Wider Context	227
8.5 Chapter Summary.....	228

Chapter Nine: Conclusion.....	230
9.1 Summary of the Study.....	230
9.2 Summary of the Research Findings.....	231
9.3 Limitations of the Current Study.....	234
9.4 Directions for Future Research	235
9.5 Concluding Remarks.....	235
Appendix 1: English Questionnaire	237
Appendix 2: Chinese Questionnaire	247
Appendix 3: Interview Questions.....	256
Appendix 4: Interview Film Card	259
Appendix 5: Film Clip Descriptions.....	262
Appendix 6: Sample Individual Interview Transcript.....	271
Appendix 7: Sample Group Interview Transcript.....	281
Appendix 8: List of Data Analysis Codes.....	299
References	308

Acknowledgements

“学海无涯- *Learning never ends*”. (Chinese proverb)

My warmest and heartfelt thanks go to my supervisors Dr Anwei Feng and Professor Mike Fleming for their encouraging and inspiring supervision. I am deeply indebted to both of them for their constant guidance, support, patience and encouragement to me and their confidence in me throughout the journey. I am also indebted to Professor Mike Byram for his insightful and valuable remarks on various occasions.

I am grateful for various financial support provided by University of Durham, Intercultural Studies Group in the School of Education and Ustinov College during the course of my research.

I would like to express my deep appreciation for the support of the teachers from all the universities that I visited for my fieldwork in Beijing. I also truly appreciate all the students who voluntarily took part in my pilot study and fieldwork. A special thank you goes to Anita Shepherd for her patience and professional and efficient administrative support throughout the whole course.

I have benefited from the opportunity to present and discuss my work with scholars who specialise in intercultural studies from around the world at annual *Cultnet* meetings from 2007 to present. Their comments and feedback have been valuable to me. Here, I would like to express my deep gratitude to them.

I would also like to thank Dr Penny Wilson and Miss Theresa McKinven for their support and trust in me founding and leading the Ustinov Intercultural Forum (UIF) from 2006 to 2009. In addition, a warm thank you goes to the section of Intercultural Dialogue, Culture sector, UNESCO, for providing me with a three-month internship opportunity in 2008 in Paris, France. By applying professional knowledge in practice and exploring ideas with an intercultural team, I gained valuable experience, skills and insights, on both an academic level and a personal level.

On a personal level, I would like to thank my parents, Xueling and Yawen, for their unconditional and consistent love, support, encouragement, intelligence and inspiration throughout the whole course. Above all, I would like to thank my loving husband, Andrew, for his keen eye for typographical errors and his intellectual comments on my thesis that are surpassed only by his affection, tolerance, and willingness to provide many cups of tea.

Declaration

This PhD thesis is my own work and no part of the work contained in it has been submitted for a degree at this or any other university.

Statement of Copyright

The copyright of this thesis rests with the author. No quotation from it should be published without prior written consent and information derived from it should be acknowledged.

Chapter One: Introduction

Let me begin this thesis by telling you a story about myself. In the middle of the 1980s, I was a pupil in primary school in a beautiful city located in the northeast of China. At that time, my dad went to Canada to work for a few years. There was only mum and I at home. We kept in touch with dad by writing letters. Telephone wasn't common in households at that time. In 1989, my dad came back from Canada. I was 11 years old. He brought lots of gifts for me and mum. Along with the pretty dresses, the Yamaha keyboard and many other gifts, dad brought back a colour TV, a video cassette player and 20 video cassettes. Each video cassette had five films. Dad said those films were the most popular ones in Canada. At that time, video cassettes with foreign films were not accessible in the stores in China. There were not so many programs on TV, and only black and white foreign films were broadcast on TV. Colour TV wasn't common either. It was the first time that I watched *Star Wars* (1977). Unlike the black and white films broadcast on TV, which were dubbed in Chinese, the film was in English with no subtitles. Although I couldn't understand the language, I still remember how my eyes were glued to the images, how fascinated I was by the sound and the story, and how I kept asking dad to translate what the characters on the screen said. I still remember how amazed I was by the shiny and colourful light swords those warriors used, and how scared I was by the bad guy in the black mask and the black cape. That was when I fell in love with English films.

We moved to Beijing, the capital of China, after I entered the secondary school. Although most of the students started learning English in the first year of junior high school, dad had started teaching me English when I was in primary school. I loved learning English and I loved watching English films. I enjoyed imitating the way the characters spoke. From junior high school to high school, I rarely missed any foreign films broadcast on TV, although they were dubbed in Chinese. I always tried to persuade my parents to buy me more films from the stores. I still remember how much I loved *The Lion King* (1994) and *Pretty Woman* (1990).

After I entered the university to study English as my major, dad bought me another gift, a Sony mini DVD-player! I could carry it in my bag wherever I went. I was so excited and gave him a big hug! That was the beginning of my journey of learning English through watching films and becoming a film-buff. At that time, we could buy pirated VCDs or DVDs from the library bookstore. Each film cost only 5 yuan, which is equivalent to 40 pence. I could even get a discount as well if I bought more than three films at a time. I was one of their favourite customers because I visited the bookstore whenever I had time to check whether they had any new English films, and I rarely left with empty bags. In order to improve my English, I still remember that I watched *Home Alone*

3 (1997) about 20 times to try to learn all the sentences said by the characters in the film. I watched films whenever I had time. Since I was the only one who had a mini DVD-player in our year, sometimes I had film-nights in our dorm with all the other girls crowded around my player!

As time went by, I watched almost all the pirated films I could find. I felt that I benefited greatly from my learning-while-being-entertained method. Due to the fact that most of the films that I watched were American films, I gradually picked up an American accent and learned more and more expressions suitable for use in various scenarios that could not be learnt from textbooks. To this day, even though I have lived in the U.K. for a number of years, when people first meet me (including the first time my husband-to-be met me) they ask me the same question: "You have an American accent. Have you lived in America before?"

During my four-year undergraduate program, I taught English to young students aged from 6 to 14 on a part-time basis. In doing so, I gained strong interest in teaching English. After completing my undergraduate degree, I went on to study an M.A. in English language teaching (ELT) and Applied Linguistics at King's College London. One of my favourite courses was *Intercultural Studies*. Due to my strong interest in intercultural studies in English language teaching, upon my graduation at King's College London, I applied for and got an offer for the PhD program in Intercultural Studies at School of Education, Durham University. Before I started my PhD study, I taught English listening and speaking for first-year students in a university in Beijing, China, from 2005 to 2006. During that one-year teaching, I found that watching foreign films and TV series had become one of the common activities in Chinese college students' lives. With the development of technology and the economy, they could get pirated DVDs from stores or even download them for free from the internet. Although the media is censored in China and the government imports less than 20 foreign films and TV series each year, students could find almost any films or TV series they wanted on the internet and download them free and fast.

I tried using some film clips in the classes to help my students improve their listening and speaking skills. I consulted some of my colleagues to try to find out good approaches that they could recommend. However, only one or two had tried to use films in their classrooms, and the most common approach was to show a full-length film on Friday for an easy lesson. Although films were always very popular among students in the class, deep down in my mind I couldn't help thinking that, as films are such rich, powerful and attractive materials, there has got to be a better way to use them, and I am going to find that way!

My passion for intercultural studies and exploring the value of films in ELT made me start looking at these two issues together. In the field of ELT, Byram's (1997) notion of intercultural

communicative competence (ICC) describes a person who not only is able to conduct successfully face-to-face intercultural communication, but also is interculturally competent in interpreting foreign cultural products. As a language instructor in ELT, an English language learner, a film-buff and a keen researcher, my attention was gradually drawn by several key aspects of ICC which are directly relevant to 'interpreting the cultural product', such as knowledge of self and other, openness and curiosity, ability to decentre and relate, and critical cultural awareness. As an English language learner and a film-buff, I had personally benefited from watching foreign films and TV series in terms of improvement of linguistic competence and entertainment, but I had never consciously watched films treating them as foreign cultural products, which is what they are. Having started seeing foreign films as foreign cultural products from an intercultural perspective, I couldn't help but wonder, how do language learners in general interpret the films? Do they watch films critically? Do they simply take the films at their face value? Do they learn anything about foreign people and foreign countries as result of watching foreign films? Considering how easily accessible foreign films are for language learners, and how common it is to watch foreign films nowadays among college students, I started feeling a kind of concern and responsibility. I felt that, as a language instructor, it was important to find out how my students *make sense* of these cultural products, and to find out ways to help students develop their intercultural communicative competence by using them. This led me to the aim of the current study, which is, as the title of this thesis indicates, *An Investigation into How Chinese College Students Make Sense of Films and TV Series from an Intercultural Perspective: Implications for English Language Teaching*.

One might notice that I use the phrase 'make sense of' instead of the word 'interpret' when talking about foreign films. I don't intend to make any clear distinction between these two phrases, which seem to be used inter-changeably by people most of the time. The reason why I use 'make sense of' instead of 'interpret' is that, personally, I think that 'make sense of' gives more space than 'interpret'. It seems to me that 'interpret' emphasizes the 'meaning' more, and 'make sense of' includes both the 'meaning' and the 'actions' which produce the meaning. Hence, I consider that 'make sense of' suits the spirit of the current study better.

To fulfil the broad aim of the current study, six research questions were proposed.

RQ1: From which resource do Chinese college students (CCSs) think they learn the most about the people and cultures of English speaking countries, in particular the U.K. and the U.S.A.?

RQ2: What type(s) of media do CCSs prefer to use in order to learn about people and cultures of the U.K. and the U.S.A.?

RQ3: How do CCSs make sense of films and TV series produced in other cultures, specifically films and TV series produced in the U.K. or U.S.A? (core question)

RQ4: Are there any discernible effects of foreign film viewing on CCSs' understanding of and attitudes to other peoples and cultures? If so, what are they?

RQ5: What is the current status of using English films and TV series in the ELT classroom?

RQ6: What are the theoretical and pedagogical implications for English teachers in the Chinese context?

The study was conducted in China. Research subjects were non-English-major Chinese undergraduate college students. English majors were excluded because of two main considerations, the level of their English proficiency and their pre-existing knowledge of the target countries, neither of which is representative of college students who do not specialise in English.

To answer the above research questions, the thesis will begin by providing a brief account of research context (chapter two). Chapter three will provide the theoretical background to the current study by reviewing existing literature in three areas. The first two areas are mass communication models and effects (with particular emphasis on audiences), and intercultural communicative competence in English Language Teaching (ELT). The third part of literature view, which deals with the use of foreign films and TV series in English language teaching in both Chinese and non-Chinese contexts, will not only present the research background, but will also address Research Question 5 by providing the current status of using English films and TV series in ELT.

Following the literature review, chapter four will describe the research methodology used in the study, including the qualitative (semi-structured individual and group interviews with film-clips-viewing) and quantitative (questionnaire) data collection methods adopted for both the pilot study at Durham and the fieldwork in China. The data analysis techniques employed will also be discussed.

Chapter five will illustrate the empirical findings gathered from the questionnaire which answer Research Questions 1 and 2. Some of the relevant findings gathered from semi-structured interviews will also be presented.

Chapter six focuses on presenting the empirical findings related to Research Question 3, which unveil how Chinese college students make sense of foreign films and TV series. These findings,

which identify five main categories of sense-making activities, emerge from the semi-structured interviews. Variables which influence the sense-making activities will also be identified.

Chapter seven will illustrate empirical findings related to Research Question 4, which deals with discernible effects of viewing foreign films on Chinese college students' knowledge of and attitudes to foreign peoples and cultures. Variables which influence these effects will also be discussed.

Chapter eight is the discussion chapter, which will fulfil two functions. First, it will provide supplementary empirical findings gathered from the semi-structured interviews for Research Question 5 (RQ5). RQ5 will be mainly answered by the literature review on using films and TV series in ELT (section 3.3). The supplementary findings are concerned with the current teaching approaches used by Chinese college language instructors. Second, chapter eight will provide answers to Research Question 6 by presenting a Foreign Media Sense-Making (FMSM) model and discussing both the theoretical and pedagogical implications of using foreign films and TV series in the Chinese context.

Chapter nine is the conclusion, and will provide a summary of the research findings, discuss the limitations of the current study, suggest some directions for future research, and, finally, provide my personal reflections on the research journey I have taken.

Chapter Two: Research Context

The purpose of this chapter is to provide a brief account of the cultural context in which the empirical research data was collected. The data was collected in China, which has been commonly known as the People's Republic of China (PRC) since 1949 when the PRC was established. China is a single-party state governed by the Communist Party of China (Walton, 2001). The government has control over mainland China and largely over the special administrative regions¹ of Hong Kong (since 1997) and Macau (since 1999). At the current date, China is the most populous state in the world, with over 1.3 billion people. It is ranked the 4th largest country in the world with a land area of more than 9 million sq km (CIA, 2010). The research subjects were college students mostly aged between 19 and 20 in 2007 when the interviews and surveys were conducted, and so most were born in 1987 or 1988. This chapter will discuss both the education system they were studying in and their educational background, with particular focus on the English language education they have received prior to participating in the study.

2.1 Education Systems in China

"Education guidelines: education must serve the socialist modernization drive, be integrated with production and labour and foster builders and successors with all-round development in moral, intellectual and physical education." (State Education Commission PRC, 1996)

It is stated in the Constitution of the PRC that all citizens have the right and obligation to receive education. In China there are three main education systems, which are listed below (Chinese National Commission for UNESCO and Chinese Adult Education Association, 2008:7).

- The system of school education (pre-school education, primary education, secondary education and higher education)
- The system of vocational education
- The system of adult education

The first system is the general school system in China, within which higher education is the focus of the current study. This system is described in more detail in the following section. The vocational education system includes vocational and technical education, which aims to meet the society's demand for high quality, skilled workers. Adult education is a kind of basic education for adults who seek to develop their own talents and other potential continuously, improving their

¹Special-administrative region: Is a provincial-level administrative division for PRC, for which creation is provided by Article 31 of the Constitution of the People's Republic of China. Article 31 says "The state may establish special administrative regions when necessary. The systems to be instituted in special administrative regions shall be prescribed by law enacted by the National People's Congress in the light of the specific conditions". (Elihu & Greenwood, 1999:394)

moral and scientific competence and adapting themselves to the economic, cultural and social changes. Adult education is also a broad channel which provides opportunities to satisfy people's needs in life and help them achieve individual development and 'personality perfection' (ibid).

2.1.1 School Education System

In China the current regular schooling system consists of 3-year kindergarten (for 3-5 year old children); 9-year compulsory education (6-year primary education and 3-year junior high school education in most provinces, or 5-year primary education and 4-year junior high school education in a limited number of provinces); 3-year senior high school education and higher education (4-year college education; and graduate education for 2-year master's and 3-year doctoral degrees (ibid).

The general trend in China is for school education (pre-school, compulsory and senior high school) and higher education to be financed by the state, and vocational education and adult education to be financed by other social sectors.

Upon completing senior high school, students who apply for tertiary education will take the annual National Higher Education Entrance Examination², commonly known as the Gao Kao (高考), designed by Ministry of Education in mainland China. This examination is a prerequisite for entrance into almost all higher education institutions at the undergraduate level in mainland China. It is usually taken by students in their last year of high school in mainland China, although there has been no age restriction since 2001. Some other students who apply for adult education will take other tests designed for adult education (Chinadetail, 2011).

2.1.2 English Language Education in the School Education System

In China the curriculum (for all subjects) is developed for three stages: pre-school; primary school; and junior-high and high school. The curriculum for pre-school is formulated by the state education commission. The curriculums for the other two stages, primary school and junior-high and senior-high school, have two levels, state-determined and province³-determined. The curriculum designed by the state refers to the unilateral compulsory curriculum. The province-

² Tertiary education entrance examinations started in the early years when modern universities emerged in China, and continued after the People's Republic of China was established in 1949 until the Cultural Revolution began in 1966, at which time the education system and other sectors of life were disrupted. The first National Higher Education Entrance Examination was held in 1977, after the Great Cultural Revolution. It was a history-making event. There was no limit on the age or official educational background of examinees, and consequently it provided opportunities for those from the society who wanted to try their luck in the examination after the ten years of the Great Cultural Revolution. The youngest were in their early teens, and the oldest were in their late thirties. The total number of candidates in the national college entrance exam of 1977 was 5.7 million. Although the Ministry of Education eventually expanded enrolment, adding 63 000 more to the university admission quotas, the admission ratio was the lowest in history of the PRC, only 4.8%, with 272,971 students being admitted to university. (Wei, 2008). For more information on Great Cultural Revolution, please refer to Bo Ma, 1995 *Blood Red Sunset: A Memoir of the Chinese Cultural Revolution*, New York

³ Province 省: administrative divisions of the People's Republic of China. There are 22 provinces in total.

determined curriculum mainly aims to facilitate the local economic and cultural development, and is arranged by the educational authorities of the provinces and autonomous regions under the direction of the central government. This indicates that, while following the guidance of the unified national curriculum, the local-curriculum in each province may vary (State Education Commission PRC, 1996).

In terms of English language education, according to the National report provided by the State Education Commission of China in 1996, English was not one of the listed subjects in the state-curriculum in the pre-school stage in 1996. At this time my research subjects were in primary school, and at that time in the primary school stage only some schools offered foreign language teaching (i.e. English) due to differences among schools (e.g. school finances, human resources, etc).

However, English was already one of the compulsory subjects offered in junior-high and high schools. A summary of the total number of class periods (45 minutes each) of each compulsory subject provided by junior-high school and high school in 1996 is provided in Table 2.1. In junior-high school, students could choose to study foreign language (i.e. English) for either 204 or 400 periods. Students had the flexibility to study English for additional hours. This means that most of my research subjects started learning English in the first year of junior-high school. Hence, when graduating from high school, they had already studied English for 6 years.

In tertiary education, College English is only compulsory for non-English majors for the first two years. Students can self-study in the next two years. Undergraduate students who are non-English majors must pass CET⁴ (College English Test) Band 4 or Band 6 in order to get their degrees (Lin, 2008). Consequently, it is safe to assume that by the time when I collected my empirical data my research subjects had already studied English for around 8 years.

It is worth mentioning that in 2001 the Ministry of Education issued the first set of *primary school* English text books, and encouraged primary schools to start offering English lessons in several regions in China (Ministry of Education, 2001). Nowadays, primary schools start offering English lessons in year three in most cities (Lin, 2008). This means students who entered primary school in or after 2001 will most probably receive a longer period of English education than my research

⁴ College English Test (CET): The CET consists of the non-English-specialized "Band 4" (CET4), in which certificate-holders have reached the English level required of non-English major undergraduate students. The certificate-holders of "Band 6" (CET6) have reached the English level required of non-English major postgraduates. The test originally included listening, reading and writing sections. The spoken test was optional and required certain points from the written test. The CET was reformed in 2005. Several changes were made, including: Re-ordered and re-organized sections; more listening and spoken sections; new "Skimming & Scanning" and "Translation" sections; New grading system: scores are now graded on a curved scale, so that the highest score possible is 710, while the lowest mark is a score of 290 (finish all questions but all wrong); Passing grades and qualification certificates were eliminated; A more detailed score report is provided on each section. (Ministry of Education, 2005)

subjects before entering university. However, whether the differences in the number of years of learning English will result in differences in the English proficiency of graduates has yet to be shown.

Junior-high School (3 years)		High School (3 years)		
Subject	Period	Subject	Period compulsory	Period alternative
Moral	200	Moral and Politics	184	
Chinese	534	Chinese	380	
Maths	468	Maths	390	
Foreign language 1	204	Foreign language	289	96
Foreign language 2	400			
History	200	History	136	120
Geography	153	Geography	102	120
Physics	164	Physics	187	127
Chemistry	96	Chemistry	187	96
Biology	153	Biology	102	72
Sports	200	Sports	184	
Arts	100	Arts	68	
Labour skills	200	Labour skills	4 weeks a year	
Music	100			

Table 2.1 Chinese Junior-High and High School class periods

Having briefly reviewed the school education system, and, in particular, English language education in China, the following section will provide a brief account of media censorship and media piracy in China.

2.2 Media Censorship and Piracy in China

In China, there are different forms of media, including newspaper, television, internet, radio etc. Bearing in mind the purpose of the current study, this section mainly focuses on two types of media, television and internet.

In 1978 only 13.8% households had television in China. All of these were 9 inches black and white televisions made in China. There was no access to foreign-brand televisions (Chen and Hu, 2011). Radios and newspaper were the two main forms of media. In that same year (1978), the Chinese government permitted the importation of technology from abroad for the purpose of manufacturing colour televisions. In 1982, the first major colour television production started. By the end of 1980s it was becoming more and more common for households to have colour television (Liu, 2006). From the founding of the People's Republic of China in 1949 and until the 1980s, almost all media organisations in China were state-run (Zhang and Xiao, 1998).

On September 20, 1987, China's first E-mail, titled "Crossing the Great Wall to Join the World," marked the beginning of the use of the Internet by Chinese. With the development of the

economy and technology, since the end of 1990s more and more Chinese have started using the Internet (China research and education network, 2001).

The following sections will discuss two main features of media in China, censorship and piracy.

2.2.1 Media Censorship in China

Censorship in China is officially implemented by the government of the country. The special administrative regions of Hong Kong and Macau have their own legal systems, and are largely self-governing, so these censorship policies do not apply there (Sino-British Joint Declaration, 1984). Censored media include essentially all forms of media which are capable of reaching a large audience, including television, film, print media, radio, theatre, text messaging, instant messaging, video games, literature and the Internet.

The two primary censoring agencies are the General Administration of Press and Publication (GAPP) and the State Administration of Radio, Film, and Television (SARFT). GAPP licenses publishers and screen written publications (including those on the Internet), and has the power to ban materials and shut down outlets (Preeti et al, 2010). Also, it restricts foreign journalists' access to China for interviews (Jia, 2004)

- Foreign media

SARFT has similar authority to GAPP over radio, television, film, and Internet broadcasts (Preeti et al 2010). With regard to foreign media, the reception of international radio services, such as VOA and BBC, is restricted. In cities, the interference is especially strong. There are also restrictions on international satellite services. Only hotels with a three star or higher rating have permission to receive such signals. Generally, with the exception of government officials of a certain ranking, the general public is kept from receiving such services (Jia, 2004).

There is no motion picture rating system in China. Hence, films must be deemed to be suitable for all audiences in order to be allowed to screen (The Guardian, 2006). For foreign-made films, this sometimes means controversial footage must be cut before such films can play in Chinese cinemas. Only twenty new foreign films a year are allowed to show within the country (Devin, 2007).

- Internet

According to an empirical survey conducted by two students at Harvard, at least 18,000 websites are blocked from within the country (Zittrain and Edelman, 2002). Banned sites have included YouTube (CNN, 2009), Facebook (from July 2009) and Twitter (Wauters, 2009). More recently,

through individual negotiations with the Chinese government, Wikipedia (Barak, 2008) and Google (The New York Times, 2010) have been opened up for public viewing (with certain restrictions) from within mainland China.

Despite all the censorship, as mentioned in the introduction, people still can access foreign films and TV series easily by purchasing pirated DVDs and downloading from the internet. The following section will focus on the reasons behind this media piracy in China.

2.2.2 Media Piracy in China

“No country contributes more to the piracy problem, or will play a more critical role in shaping the future of international piracy, for better or worse, than China.” (Priest, 2006:796).

According to copyright industry estimates, more than 90% of all music CDs, film DVDs, and software sold in China is pirated (Priest, 2006:798). As mentioned in the introduction, based on my personal experience and observation, most of the foreign films and TV series sold in China are pirated. When I was in the university, pirated foreign films in DVDs were available in many different stores, bookshops, supermarkets and audio-visual stores etc. I still remember that after I graduated from King’s College London and went back to Beijing in 2005, I asked one of my cousins to find out where I could buy genuine DVDs because I got used to buying genuine DVDs from HMV⁵ when I was in London. She was a bit confused and said: “we don’t buy genuine DVDs, only pirated ones. Even if you want to buy genuine DVDs, you cannot find them anyway”. In the last couple of years the situation has changed a lot, and in 2010 I observed pirated DVDs are now only available from street vendors, market stalls and backstreet shops, not from major supermarkets and chain stores. Only genuine DVDs (and music CDs) can now be purchased from official shops.

By 2004, China had the second-highest number of internet users in the world. It has been estimated that this number is increasing by 27% annually, and by January 2006 had reached approximately 110 million users (Jiang, 2004). Internet piracy provides alternative access to foreign media programs, such as films and TV series. Using Baidu⁶ or Google to search, it is not difficult to find out that there are many websites (both Chinese and foreign) that offer free-viewing and free-downloading. In addition, the characteristics of a multi-media player called Bao Feng Ying Yin (暴风影音), which was created by Chinese computer programmers, has made watching pirated foreign films downloaded from internet very easy. The software can be easily found by using any search engine, and downloaded for free. Once installed it can play many kinds

⁵ HMV: HMV Group is a British global entertainment retail chain store. It sells CDs, DVDs, games, MP3, concert tickets etc.

⁶ Baidu: Baidu Inc offers many services, including a Chinese search engine for websites, audio files, images, and audio-visual (e.g. film) programs.

of audio- and audio-visual files which many other media players cannot play. When I was in China in 2007, I found out that this multi-media player had become the most commonly used software for watching pirated films downloaded from the internet.

2.3 Chapter Summary

This chapter has provided a description of the cultural context of the current study. Bearing the focus of the study in mind, two main aspects of the cultural context were presented. First, a brief account was given of the school education system in China and the English education provided (pre-school, primary-school, junior-high school and senior-high school). Second, media censorship and piracy, particularly in regard to foreign media, were reviewed, combining some of my personal experiences and observations with literature findings.

It is clear that, although the media is censored in China, Chinese people can still easily access a wide range of foreign films and TV series at very little or no cost, due to media piracy. In universities/colleges both teachers and students have access to DVDs or video cassettes of films, pirated or genuine, for classroom use.

Having described the research context, the next chapter will review the literature which provides the theoretical background for the current study.

Chapter Three: Literature Review

Having provided a brief account of the research context in the previous chapter, this chapter reviews the literature which provides the background to the current research project. First, the literature concerned with the mass media communication process will be reviewed. Due to the fact that, among all six research questions, Research Question 3 (How do Chinese college students make sense of films and TV series produced in the U.K. and U.S.A.?) is the core question of the current study, the literature dealing with *audience* will be discussed in most detail. The literature concerning media's effect on audience will be discussed as well. This literature is relevant to Research Question 4 (Are there any discernable effects of film viewing on Chinese college students' understanding of and attitudes to other people's and cultures? If there are, what are they?).

Second, the development of the aims and purposes of English language teaching (ELT) will be reviewed with a focus on the development from linguistic competence to intercultural communicative competence (ICC) in ELT. Here, the term ELT is used to represent both EFL (Teaching English as Foreign Language) and ESL (Teaching English as Second Language). The term EFL is often used to describe the teaching of English in countries where English is not widely used functionally, while the term ESL often describes the teaching of English in a country where English is used functionally, either as a first or second language. However, I am aware that this distinction is not perceived consistently by all scholars in the world (see Nayar Bhaskaran, 1997).

The third section deals with a wide array of literature containing pedagogical claims of *WHY* and *HOW* to use films and TV series in both the Chinese context as well as the non-Chinese context in ELT. The final section provides a critical discussion of the literature mentioned above.

3.1 Mass Media Communication & Effects

The Oxford Advanced Learners' Dictionary defines *media* as the plural form of *medium* (2003:796). In Buckingham's understanding, a medium is something that people use when they want to communicate with others indirectly instead of directly face-to-face (2003). The word *mass* refers to 'a large number of people' (Oxford Advanced Learners' Dictionary: 790). The definitions of these two words convey two fundamental features of mass media. First, media exist in different forms, such as printed (newspaper, magazine), audio (radio) and audio-visual (films and TV series). Second, media is designed to reach large number of audiences (Kolker, 2009). Hence, traditionally, the nature of mass media communication (in short, mass communication) has been perceived as one-directional, one-sided and impersonal, which makes mass communication different from

other types of human communication (McQuail, 2005). Recently, with more and more options available, such as phone-in, on-line voting and text-messaging, there have been more interactions between the media and the audiences. However, film-viewing and television-viewing (i.e. TV series) still remain one-directional and one-sided communication most of the time.

In the school of media study, different scholars have different understanding of the mass communication process, as well as the parties involved in the process. The following section will further explore these issues by reviewing several influential mass communication models used in the media study discipline.

3.1.1 Mass Communication Models

Traditionally, mass communication has been perceived as a linear process (Hiebert and Gibbons, 1999). For example, American political scientist Lasswell (1948) describes the mass communication process by asking following questions:

- Who?
- Says what?
- In which channel?
- To whom?
- With what effect?

This has been known and cited as the Lasswell Formula, and has been illustrated clearly by a diagram produced by McQuail and Windahl (1993:14) and reproduced here in Fig. 3.1.

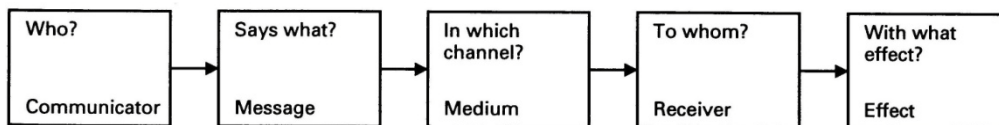

Fig. 3.1 The Lasswell Formula with corresponding elements of the communication process (Lasswell 1948)

The Lasswell Formula has received criticisms which mainly fall into two categories. One, it has been considered as too simple. It takes for granted that the communicator has some intention of influencing the receiver. Second, it assumes that the effect is always there. However, one thing worth mentioning is that Lasswell's interest, at the time, was political communication and propaganda. For analysing propaganda, the formula fits well (McQuail and Windahl 1993: 14-15).

Braddock (1959) developed the Lasswell Formula further by adding two more features, the context of the communication and the communicator's intention. Also, Braddock does not

assume that the effect is always there. However, in Braddock's model (as shown below), mass communication is still a linear process, which means the communicator produces the message and delivers the message via a medium to a receiver/audience. Another commonality the two models share is that the communicator is the one who decides the meaning(s) attached to the message, not the audience.

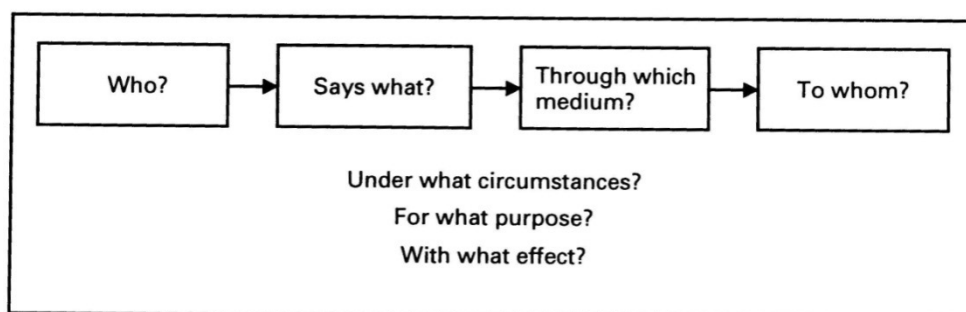

Fig. 3.2 Braddock's extension of the Lasswell Formula (from McQuail and Windahl 1993:14)

Shannon and Weaver (1949) proposed a Mathematical Model of the communication process, applying a mathematical approach to communication studies. Although the model was originally used to deal with issues within the field of information theory, such as the process of communication via telephone (explaining the technical jargon appearing in the model), it has been used analogically by behavioural and linguistic scholars (McQuail and Windahl, 1993: 16).

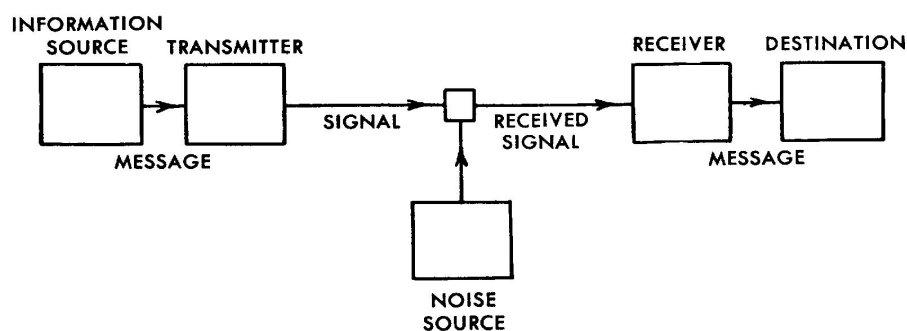

Fig. 3.3 Shannon and Weaver's 'Mathematical Model' (Shannon and Weaver, 1949).

As shown by the model, first in the process is the 'information source' (i.e. director of a film/communicator) producing a message (i.e. the meaning that the director wants to convey) to be communicated. In the next step, the message is formed into 'transmitter' (i.e. film) which delivers the signal (i.e. sound and moving images in the film). The signal is received by the receiver (i.e. audience's visual and audio senses) who then reconstruct the message (the meaning as interpreted by the audience) based on the received signal. Finally, the message reaches the destination which is audience's consciousness. The 'noise' interferes with the signal before it is

received by the audience. For example, in a cinema, the sound of the film may be interfered with by another audience member's cough, and the picture may not be clear. The presence of 'noise', to some extent, may interfere with the audience's reconstruction of the meaning which is intended by the director. If there is too much noise, the meaning may be lost all together.

Comparing the above three models, Lasswell's is the most linear and simplest. Although Braddock added three more features into the model, it is still linear in nature. What makes Shannon and Weaver's model different is that they point out that the intended meaning (by communicator) and the received meaning (by receiver/audience) may not be the same due to the presence of 'noise', which is environmental in nature. However, none of the three models look at the characteristics of the 'receiver'.

Maletzke (in McQuail and Windahl, 1993:46-53), a German scholar, proposed a very detailed communication model which was developed from the school of social psychology. The model gives a very detailed account of the 'communicator', the 'medium' and the 'receiver'. Considering the focus of current study, the discussion here will focus on the receiver part of the model.

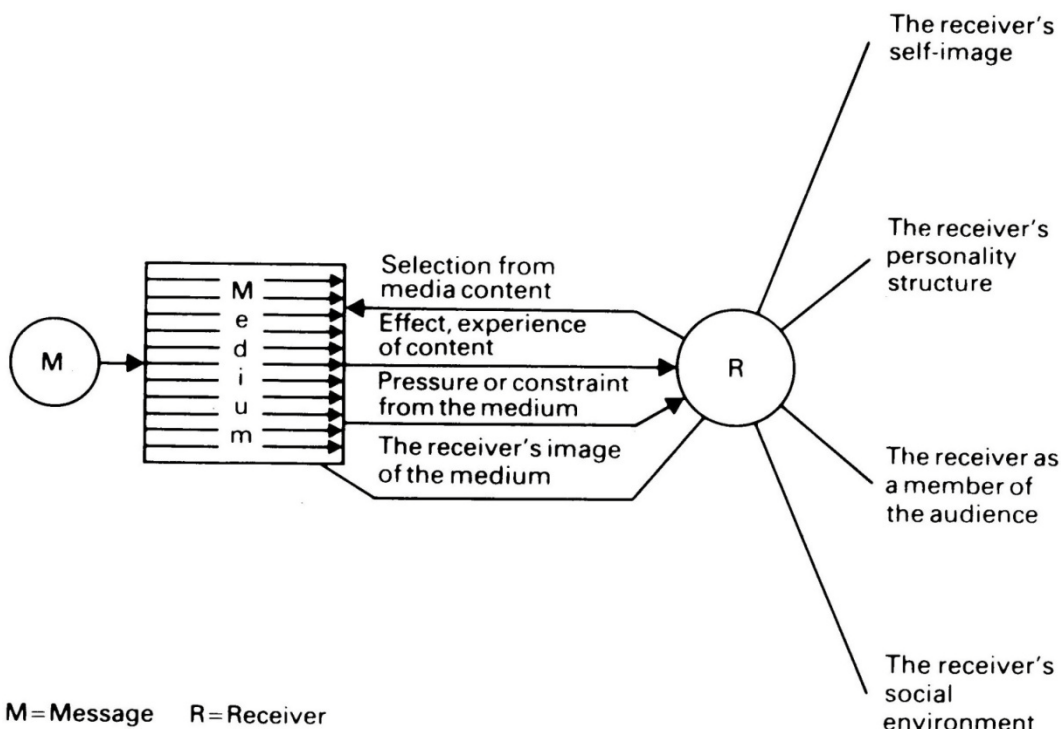

Fig. 3.4 The receiver part of the Maletzke model, showing audience behaviour as the result of a number of factors (Maletzke 1963)

According to Maletzke, various factors affect the receiver's reconstruction of meaning (e.g. making sense of a story in the film). Factors fall into two main categories, 'personal factors' and 'medium-related factors'. Personal factors are the ones which are directly relevant to receiver

him/herself, such as 'self-image' (perception of self), 'personality structure', 'social context' (the society and community where receiver live, groups s/he belongs to, people whom s/he interacts with). Medium-related factors refer to the interaction/relationship between the medium (i.e. film) and the receiver (audience), including 'selection from media content' (e.g. what to watch depends on expectation from media), 'the receiver's image of the medium' (i.e. like or dislike, trust or distrust), 'effect, experience of content' (e.g. whether or not enjoy viewing the film), and 'pressure or constraint from the medium' (i.e. the limits of the nature of the media).

One main point illustrated by the model is that the process of mass communication is very complex, and far from being linear in the way early models suggested. Also, meaning produced by the receiver is not always the same as the meaning the communicator planned to deliver, due to the influences of many complex factors during the process.

The above models illustrate an important development in the understanding of mass communication process. The process is complex in nature and is affected by everything involved in the process, including the communicator, the media, the audience and the effect (Baran and Davis, 2008; McQuail, 2005).

Within the school of 'audience research' (e.g. Alasuutari, 1999; Livingstone, 1993; Jensen and Rosengren, 1990; Ang, 1985), one research direction is studying an audience's interpretation of media (also known as 'audience reception study' see O'Sullivan, 1998; Staiger, 2005), which includes issues such as how an audience makes sense of TV series (i.e. Livingstone, 1998) and films (i.e. Steiger, 1992). The essence of this approach is giving the power to the audiences who give meaning to messages (Jensen and Rosengren, 1990). This means the audiences are the ones who produce the meaning of the messages. In addition, this approach studies audiences from a cultural perspective. This means that the approach emphasizes an understanding that messages always have multiple meanings, and are interpreted according to the context and culture of audiences (McQuail, 2005).

One of the forerunners of reception analysis, Stewart Hall (1980), proposed an Encoding/Decoding model, which was formulated in relation to television, but could also apply to any mass medium (i.e. film).

What Hall specifically points out is that the two acts, the communicator encoding media with a planned/preferred meaning, as well as the audience decoding the media, are both affected by their own cultural background, such as their own experience and outlook. This means that audiences do not necessarily decode (make-sense/interpret) the media as the communicators (i.e. director) planned, and may produce different or even opposite meanings. Hence, the general

implication of Hall's model is that meaning as decoded does not necessarily correspond with meaning as encoded (Baran and Davis, 2008; Ruddock, 2001).

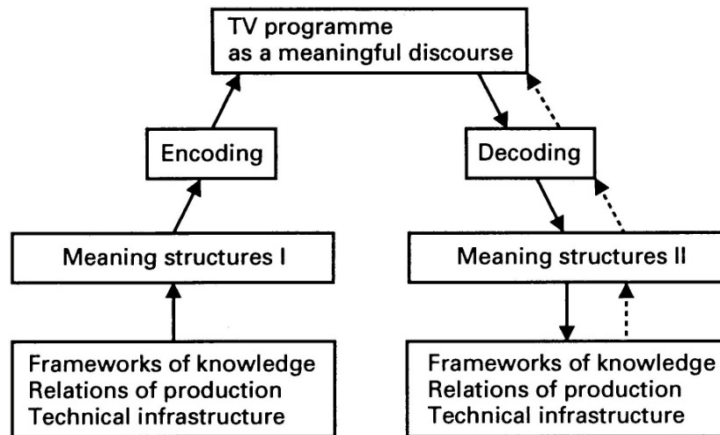

Fig. 3.5 Hall's encoding/decoding model (Hall 1980)

Although Hall developed the model in the domain of culture, and pointed out that the audiences' cultural background affects their making sense of media, Hall did not explain *how* and *in what way* cultural background affects the audiences.

Hall's model has been widely applied by studies that focus on audience reception analysis (McQuail, 2005). Among audience reception studies, one of the focuses is to study particular audiences with domestic fictional media programs, in particular films and TV series. Such studies include women and soap opera (i.e. Geraghty, 1991), adolescents and TV series (i.e. Pasquire, 1996), children and films (i.e. Tobin, 2000), children and TV series (i.e. Buckingham, 1996) and adult audiences with TV series (Morley, 1986; Livingstone, 1990).

Studies on audiences with foreign fictional TV series have also been conducted (e.g. Liebes and Katz 1986; Biltereyst, 1991). Liebes and Katz (1986) did a comparative study of how audiences from Israel and the U.S.A. make sense of an episode of *Dallas*⁷, a popular American TV series. Another comparative study was conducted by Biltereyst (1991), who also used *Dallas* to study American audiences and audiences from one of the European countries.

In the Chinese context, studies on Chinese audiences with domestic fictional media have been carried out as well. For example, Friedman (2008) conducted a study in Taiwan focusing on Taiwanese audiences' reception of the Taiwanese film *Twin Bracelets*⁸ (1991) (the actors speak

⁷ *Dallas* (1978-1991): it is an American prime-time TV series that originally ran from 1978 to 1991. It revolved around the Ewings, a wealthy Texas family in the oil and cattle-ranching industries. The show was broadcast for thirteen seasons from 1978 through 1991 (IMDB, 2011)

⁸ *Twin Bracelets* (1991): the film tells a story about two girls who are best friends, in a remote fishing village, struggle to remain committed to their declaration of love in their tradition-bound society (Chinesetapes, 2011)

mandarin in the film). The research subjects were from various age groups, from teenagers to grandparents.

In terms of Chinese audiences with foreign fictional media, Zhang and Harwood (2002) conducted a research on 412 college students from a medium-sized Chinese medical college in mainland China. However, the main purpose of the research was not concerning audience reception. The intention was to find out foreign programs' impact on Chinese's traditional values. The results of their study indicated that foreign media program did have impact on Chinese college students' interpersonal harmony values. No correlation was found between foreign media and impact on Chinese values of hierarchical relations. The findings were mainly drawn from quantitative data using statistics, and hence lacked in-depth qualitative analysis. McIntyre (2003) conducted a study in Hong Kong to find out the impact of western media exposure on Hong Kong citizens' Chinese cultural values. The subjects included in the study were adults (above 18) from randomly selected households. The study applied both qualitative (telephone interview) and quantitative (questionnaire) research methods. Their research findings indicated that exposure to western media had no significant effect on audiences' 'Chineseness' (the term they used). Instead, the 'Chineseness' of the parents had significant impact. Their findings contradicted the findings from the study conducted by Zhang and Harwood mentioned previously.

As far as Chinese audience and fictional media is concerned, based on the literature the author managed to find, it seems that studies fall into two main categories. The first is audience reception to domestic fictional media. The second is foreign media impact on audiences, such as the effect on the cultural values of the audience.

In terms of how Chinese college students (CCSs) (in mainland China) make sense of films and TV series produced in the west, and in particular the U.K. and the U.S.A., few studies have been conducted (so far, no studies have been found by the author) focusing specifically on how CCSs make sense of films and TV series produced in the U.K. and U.S.A. It seems that the field of Chinese audience reception of foreign fictional media has, to date, received little attention.

The following part of the section will review the literature concerning media effects on audiences.

3.1.2 Media Effects

The purpose of reviewing the relevant literature concerned with media effects on audiences is to provide background to the Research Question 4.

RQ 4: Are there any discernible effects of film viewing on CCSs' understanding of and attitudes to other peoples and cultures? If there are, what are they?

Media product effect, in short media effect, has been one of the main areas of research within media studies (Bryant and Oliver, 2008) ever since the 1930s (McQuail, 2005). In the early stage, media were perceived as very powerful in terms of shaping people's opinions and beliefs and changing their life habits in accordance with the intentions of the communicators (Bauer and Bauer, 1960). However, this view was based on observation rather than scientific research (McQuail, 2005). This assumption was later challenged by other scholars (i.e. Berelson, 1959; Klapper, 1960). It was then proposed that media does have influence or effects, however, the effects do not always happen on a one-to-one, direct basis between the media and the audiences. This is due to the fact that external variables, such as the pre-existing structure of social relationships and the cultural context, affect in part the audiences' media choice, attention and response (Trenaman and McQuail, 1961). As research and scholarship in the area has advanced, media researchers have proposed various effect models (i.e. Scheufele and Tewksbury, 2007; Comstock et al, 1978; Rogers and Shoemaker, 1973), various types of effects and various factors which influence the effects (McQuail 2005; McQuail and Windahl, 1993).

Klapper (1960) proposed three types of effects, namely *conversion* (change of opinion or belief according to the intention of the communicator), *minor change* (change of cognition, belief or behaviour in terms of form or intensity) and *reinforcement* (confirmation of an existing belief, opinion or behaviour pattern) (in McQuail 2005:465). McQuail (2005:466) then widened Klapper's typology by adding two other possibilities, *intended change* and *unintended change*, as well as defining four levels of effects, *individual, society, institution* and *culture*.

Combining Klapper's and McQuail's works together, the effects can be re-grouped as follows (also see Hovland et al 1949):

- Cognitive (knowledge structure, belief)
- Affective (opinion)
- Behavioural (behaviour)

In terms of the *nature* of the above types of effects, several categories emerged:

- Intended
- Unintended
- Reinforced

All three types of effects (no matter what nature) can occur on individual and collective (i.e. societal, institutional and cultural) levels.

Perse (2001:51) suggested four different kinds of effects.

- Direct effects
Nature: immediate, observable, short term, emphasis on change
Audience variables: not relevant
- Conditional effects
Nature: individualised, reinforcement and change, cognitive, affective and behavioural
Audience variables: social factors, such as categories, relationships; individual differences
- Cumulative effects (gradual and long term)
Nature: cognitive or affective, rarely behavioural, based on cumulative exposure, enduring effects
Audience variables: not relevant
- Cognitive-transactional effects
Nature: immediate and short term, based on one-shot exposure, cognitive and affective, behavioural effects possible
Audience variables: schema, mood, goals

Comparing Perse's typology with McQuail's and Klapper's, one commonality they share is the three types of effects, *cognitive*, *affective* and *behavioural*. However, in terms of the nature of the effects, Perse identified the possibility of long-term and short-term (or immediate) effects. In addition, Perse took audience variables into account, including individual differences, schema, mood, goals (motivation), and social factors (culturally specific).

In terms of long- and short-term effects, similar proposals have been made. For example, Golding (1981) distinguished different types of news effects, all of which can occur on individual and collective levels.

- Planned and short term
- Unplanned and short term
- Planned and long term
- Unplanned and long term

It is important to know that Golding's focus is news effects, whilst the others refer to all types of media.

Like long term effects, 'sleepers effects', which refers to 'effects that do not show up until much later' (McQuail: 2005), has drawn attentions from researchers focusing on films (i.e. Malamuth and Check, 1981) and advertisements (Larisy and Tinkham, 1999).

Having discussed different types of effects and the natures of effects, variables which influence the effects will now be reviewed. Variables proposed by scholars can be categorized in terms of the part of the communication process they apply to, *source*, *content*, *medium* or *audience*.

- Source

McGuire (1973) suggested several characteristics of the *source*, such as credibility, authoritativeness, attractiveness and closeness to the audience, will influence the effects.

- Content

In terms of *content*, according to McGuire (1973) obtainment of the effects intended is associated with repetition, consistency and lack of alternatives. Also, it has been proposed that obtainment of the intended effects tends to be greater when the topics are distant from audience (McQuail 2005:472).

- Medium

Researchers have not been able to decide on the relative value of different types of media (McQuail 2005:472). However, Katz et al (1977) claims that, based on measures of comprehension or recall, it seems that written or verbal messages are more effective than pictorial images.

- Audience

Variables associated with audience fall into three groups, namely WHO, WHY, and HOW. WHO refers to characteristics of audience, such as, individual difference, schema, mood, social factors (Perse, 2001), level of prior knowledge (Krugman, 1965). WHY refers to reasons of viewing a program, including, goals (Perse, 2001), motivation and interest (Krugman, 1965), choice of content (Bauer, 1964). HOW deals with audience's interpretation of the program (Bauer, 1964), balance or argument (i.e. whether or not the plot makes sense to audience) (McQuail, 2005) and degree of involvement (Krugman, 1965). Ray (1973) suggested that high involvement (high interest and high attention) affect and determine the kinds of effects which occur. Similarly, Chaffee and Roser (1986) defined high involvement as a necessary condition for consistency of effects.

To sum up, the literature which has been reviewed so far identifies three different types of media effect. First is cognitive effects, which change the audience's framework of knowledge. Second is affective effects, which change the audience's attitudes and emotions. Third is the change of the audiences' behaviour. In addition, different types of effects have different kinds of *natures*, which can be long term, short term, intentional, unintentional, and reinforced, as well as sleeper.

Variables influencing the effects generally fall into four main categories, source, content, medium, and audience. Media effects occur on two different levels, individual and collective.

Having reviewed the media effect literature, bearing Research Question 4 in mind, the rest part of this section will discuss empirical studies focusing on 'the impact of foreign TV programs on domestic audiences'.

In the school of media effect studies, 'the effects of foreign TV programs on domestic audiences' appears to be a fairly new branch (Elasmar, 2003). Based on the literature the author managed to find, empirical studies, which are relevant to the current research, mainly fall into two categories.

The first category is studies to do with finding out the 'effects of imported TV programs on domestic audiences' attitudes and values'. The imported TV programs refer to all kinds of programs normally shown on TV, such as news, talk show, TV series, films and news. For example, Kang and Morgan (1988) conducted a research study to find out the impact of U.S television on attitudes of college students in South Korea. Research findings indicated that female students who viewed U.S. television tended to have liberal attitudes about gender roles and family values. In terms of male viewers, more exposure to U.S. television appeared to be associated with the hostility toward the United States and protectiveness of their own culture. Also, two studies conducted in the Chinese context (Hong Kong and Mainland China), which have been discussed in the previous section, focused on the effects of foreign TV programs on Chinese audiences' traditional values. Another similar study was conducted by Zhao (1989) to find out the effects of foreign media on Chinese women's values. However, comparing the above studies, their findings show inconsistency. For example, the study conducted in China by Zhang and Harwood (2002) showed that foreign fictional programs did have impact on some Chinese traditional values, but not all. Another study conducted by McIntyre (2003) in Hong Kong indicated weak correlation between media exposure and effect on audiences' 'Chineseness'. Although the study carried out in South Korea indicates positive correlation between foreign TV exposure and effect on attitudes, another study conducted by Elasmar and Hunter (1993) found these effects to be weak. The inconsistency of findings could be due to several factors, including research context, types of TV programs, individual characteristics and research method. In terms of research method, it seems that the use of a questionnaire survey is the most common used among the media effect researchers referred to above. The purpose of the questionnaires is mainly to find out the amount of exposure of foreign TV programs (i.e. how many hours per week etc) and the research subjects' attitudes or values toward certain topics (with the particular topics depending on research purposes). Interviews are sometimes used to obtain in-depth answers (i.e. Zhang and Harwood 2002).

The second category is studies to do with 'foreign TV programs' effect on domestic audiences' perception of foreign people and country'. For example, Zaharopoulos (1997) conducted research on Greek high school students. The findings suggest that students who watch American TV programs more often tend to have more positive perceptions of Americans' characteristics. Gender appeared to be an important variable. Females who watched American TV programs appeared to be more positive than male students who watched the same amount.

Ekachai et al (1999) conducted research in Thailand on the general public. Research findings show that frequent exposure to U.S. media is related to Thai people's perception of Americans. Possible variables were proposed, such as the direct contact and experience of the subjects to Americans.

Another study was conducted in Israel (Weimann, 1984) on American programs' effects on adolescents and undergraduates. Findings indicated that viewers generally overestimated the levels of wealth and income in America. Heavy viewers overestimated more than light viewers. Heavy viewers tend to portray a better picture of life in the U.S.A. in terms of wealth and standard of living.

Comparing the above studies, although they were conducted in different contexts with different research subjects involved, their research findings share three commonalities. First, they all focused on TV programs (fictional and non-fictional) produced in the United States. No other foreign media programs were involved. Second, they all concluded that American television does have effect on domestic audiences' perceptions of Americans. Hence, the types of effect identified were mainly cognitive. Third, the identification of correlation between the amount of exposure to media and the effects was the main focus.

Tan and Simpson (1986) conducted research both in Taiwan and Mexico. Their findings indicated: first, that American television was the major source of social stereotypes of Americans; second, that the amount of the television viewing was a strong indicator of perception and attitudes towards Americans; and third, that effects tend to be greatest when other sources of exposure are limited.

However, another study conducted by Beadle in 2003 suggested otherwise. The aim of the study was to find out American television programs' effects on Argentine management personnel's perceptions of the United States. Findings indicated that perceptions of Americans' lifestyle are not merely from exposure to media. The situation is complex, with variables such as age, education, experience, amount of television exposure, personal contact and demographic characteristics all influencing the effects significantly. The study concluded that the effect of American media on non-domestic audiences is quite weak. Similarly, Straubhaar (1999) argued

that media effects are a complex matter. In addition to exposure to media, other variables contribute to the development of perceptions and interpretations of media events. Also, the context of viewing should be taken into account.

In terms of the studies described above, three things stand out. First of all, there have been substantial studies focusing on 'effects of foreign media on domestic audiences' perceptions on foreign people and country'. However, there seems to be some inconsistency in terms of research findings. One thing worth mentioning is that the literature referred to above shows that, in terms of 'effects of foreign media on domestic audiences' perceptions on foreign people and country', television programs produced in the United States have been the main focus, not involving programs produced in other English speaking countries, such as the U.K.

Second, in general, studies focused on television programs. Both fictional and non-fictional programs which commonly appear on TV were included. Third, findings indicated two types of effects, namely cognitive and affective. However, none of the studies seem to identify the nature of the effects, such as long-term, short-term or sleeper. Several variables suggested to influence effects are amount of exposure, direct contact and experience (i.e. with foreign people), availability of source of exposure, age, education, demographic characters. Finally, in terms of the significance of media effects, there is inconsistency among research findings. Some found the effects to be strong and to be related to media exposure and gender. Some argued that effects are weak, due to the presence of other variables. One possible reason for this inconsistency is the research context, which may include the history of media contact of the country.

At this stage, it would be interesting to review the research in the Chinese context. However, no empirical studies which aim at the 'effect of foreign fictional media on Chinese audiences' understanding of and/or attitudes to other peoples and countries' have been found.

Having reviewed the literature on the mass communication process, in particular audience reception, as well as media effects, the following section will discuss the literature on 'intercultural communicative competence' in English language teaching.

3.2 Intercultural Communicative Competence in ELT

Prior to 1960s, in the field of English language teaching, foreign language learners were required to master English language linguistic competence, which was defined by Chomsky (1965) as the knowledge of systematic potential, or whether or not an utterance is a possible grammatical structure in a language. This was the main pedagogical focus at that time (McDonough and Shaw, 2003).

By the late 1960s, with the expansion of worldwide communication networks, combined with increasing travel for pleasure, business and other purposes, communication between people from different countries and cultural backgrounds was becoming increasingly common. Consequently, amongst English language educators and researchers, there was growing dissatisfaction with emphasis merely on linguistic competence in the target language. Many argued that this kind of teaching produced learners who were structurally competent, but who were often 'communicatively incompetent' (Johnson, 1981).

As a result, in the early 1970s, a deeper concept of what it actually means to know a language, and to be able to apply the language to communicate with people in a variety of settings and situations effectively, started to grow. One of the earliest terms for this concept was communicative competence (CC), which was proposed in Hymes' critique of Chomsky (Byram, 1997). Hymes (1972) criticizes Chomsky's view of language on the grounds that Chomsky paid exclusive attention to 'correctness' at the expense of 'appropriateness' of the use of language in a particular context. Hymes was concerned with the social and cultural knowledge which speakers need in order to understand and use linguistic forms. His view was that communicative competence encompassed not only knowledge, but also the ability to put that knowledge into use in real life communication.

Hymes's work proved to have substantial influence among English language educationists (Savignon, 2005). His CC model has been further developed by many educational practitioners and researchers for the purpose of ELT (for example, Canale and Swain 1980; Canale 1983; Faerch and Phillipson 1984; van Ek 1986). Two very influential models of communicative competence were proposed, one in Europe by van Ek (1986), and the other in North America by Canale and Swain (1980) (Byram, 1997). Canale (1983) also proposes a slightly modified model based on Canale and Swain's model in 1980 (Alpetkin, 2002).

Van Ek identifies six dimensions of 'communicative ability' (CA): linguistic competence, sociolinguistic competence, discourse competence, strategic competence, socio-cultural competence and social competences. In Canale and Swain's proposal, three components of CC were identified, namely grammatical or linguistic competence, sociolinguistic competence, which "... is made up of two sets of rules: sociocultural rules of use and rules of discourse" (1980, p.30), and strategic competence.

Since the mid 1980s, many educators and researchers have continued to reflect on the CC model, questioning the appropriateness of the objectives and the exhaustive quality of the concept, which for so long served its purpose, having introduced a radically different approach to the

grammar-translation method. There were two main critiques of CC. First, the notion of native speaker-based CC was considered to be idealistic and unrealistic (Corbett, 2003:4; Byram, 1997:11), because no language learners can speak in the same way as native speakers, due to different cultural backgrounds (Byram, 1997; Kramsch, 1995, 2003). Second, it was argued that the CC model fails to reflect the lingua franca status of English as well as native speakership (Byram, 1995, 1997; Byram, Nichols and Stevens, 2001).

The concept of 'intercultural communication' was introduced into the foreign language literature in the 1970s (Samovar and Porter, 1972). As a result, by the late 1980s an 'intercultural approach' to foreign and second language education was introduced (Corbett, 2003), stimulating re-examination and re-consideration of even the most basic assumptions about the function of language and the goal of ELT. Educators in the intercultural and language fields advocated greater effort to be made on the development of 'intercultural competence' (IC). A special Issue of *International Journal of Intercultural Relations* (Martin, 1989) and special issue of *Journal of Language and Intercultural Communication* (Young and Sercombe, 2010), as well as Byram's Intercultural Competence (IC) model (1997), further enhanced scholarship in this area.

Before discussing IC in ELT, it is worth looking at the development of the concept of intercultural communication. The notion of intercultural communication started in late 1950s. It was first used by the anthropologist, Edward R. Hall, who is widely recognised as the founder of the intercultural communication field (Rogers and Hart, 2002; Kitao, 1985), in his influential 1959 book *The Silent Language*. This book is mainly concerned with non-verbal human communication, and in particular how 'space' and 'time' influence how people interact with each other (Rogers and Hart, 2002:12). Gradually, the idea of intercultural communication has attracted much attention across different disciplines. In the 1960s, the emphasis of intercultural communication was on the cross-cultural communication between western experts (Cleveland et al, 1960), military personnel, and aid workers with "natives" of less developed countries (Gardner, 1962). In the 1970s, more research on different topics was done under the umbrella of intercultural communication, such as migration (Brein and David, 1971; Gama and Pederson, 1977), multicultural education (Dolce, 1973; Pearson 1977), racism in American education (Landis, 1977) and cross-cultural training (Fiedlera et al, 1971). In the 1980s, with further development of travel, business and education, more research topics appeared, such as immigrants in American universities (Ting-Toomy, 1981), business (Adelman and Lustig, 1981), intercultural competence for migrants in America (Martin, 1987), and second language education (Pesner and Auld, 1980).

Attempts have been made to define intercultural communication. Jandt (2004) defines intercultural communication as face-to-face interactions among people of diverse cultures.

Gudykunst and Kim propose that intercultural communication is a 'transactional, symbolic process involving the attribution of meaning between people from different cultures' (2003:17). In the field of ELT, Byram (2004) describes intercultural communication as face-to-face communication which takes place between two or more persons with different cultural backgrounds who carry different language and discourse strategies. The interaction is 'embodied into intercultural situations, comprising potential communication problems' (Byram, 1995:171). More specifically, Byram (1997) emphasizes that 'intercultural communication' is communication 'on the basis of respect for individuals and equality of human rights as the democratic basis for social interaction' (Byram, Gribkova and Starkey, 2002:9).

Comparing the above notions of intercultural communication, several commonalities can be identified. First, they all perceive the nature of intercultural communication as face-to-face interaction. Second, intercultural communication is between two or more individuals who are from different cultural backgrounds, and/or from different countries. Third, communication language normally is used in two different types of situations. For example, between two individuals A and B, the language used might be A's mother tongue and B's foreign/second language, or both A's and B's second/foreign language. In Byram's view, in the field of ELT, in terms of intercultural communication, English is used in both types of situations.

In order to increase the quality and quantity of intercultural communication, many researchers define intercultural competencies in specific disciplines, such as human resources (Storti, 2009), business (Moran etc 2009; Chen and An, 2009), international education administration (Paige and Goode, 2009), social work (Fong, 2009), engineering (Grandin and Hedderich (2009), health care (Anad and Lahiri, 2009), religious organizations (Yancey, 2009), global leadership (Jokinen, 2005) and working for global organizations (Hunter et al 2006; Griffith and Harvey, 2001). One area which has attracted lots of attention from researchers is acculturation of immigrants and sojourners in the host country. Proposed models that fall into this area are Navas's Relative Acculturation Extended Model (2005), Bennett's Development Model of Intercultural Sensitivity (1986), Hammer's Behavioural Dimensions of Intercultural Effectiveness (1987), Rathje's Coherence-Cohesion Model of Intercultural Competence (2007), Bennett's Developmental Intercultural Competence Model (1986), Gullahorn and Gullahorn's U-Curve Model of Intercultural Adjustment (1962), Kim's Intercultural Communicative Competence Model (1988) as well as Attitude Acculturation Model development by Berry et al (1989). Some other models have a more general focus, which is interpersonal communication in intercultural context. These include the Facework-Based Model of Intercultural Competence, which focuses on solving face-oriented conflict behaviour, developed by Ting-Toomey and Kurogi (1998), Deardorff's Pyramid Model of

Intercultural Competence (Deardorff, 2006), Intercultural Interlocutor Competence Models and the Worldviews Convergence Model developed by Fantini (1995), the Intercultural Maturity Model (King and Magolda, 2005), the Intercultural Communicative Accommodation Model (Gallois et al, 1988), the Model of Intercultural Communicative Competence (Arasartnam, 2008), the Multilevel Process Change Model of Intercultural Competence (Ting-Toomy, 1999), the Anxiety/Uncertainty Management Model of Intercultural Competence (Hammer et al, 1998), Deardorff's Process Model of Intercultural Competence (Deardorff, 2006) as well as the Relational Model of Intercultural Competence developed by Imahori and Lanigan (1989) after Spitzberg and Cupach (1984).

In terms of intercultural communication in the field of ELT, a widely cited model of 'Intercultural Communicative Competence' has been developed by Byram (1997) which contributed to the concept of an 'intercultural speaker' (a successful interlocutor involved in intercultural communication and interaction) in his working paper with Zarate (Byram & Zarate, 1994), which eventually influenced the *Common European Framework of Reference for Languages* of the Council of Europe (Byram, 2009). Byram's Intercultural Communicative Competence (ICC) model is 'firmly based in foreign language teaching' (Byram, 2009:322).

There are four sub-competencies of Byram's ICC, linguistic competence, sociolinguistic competence, discourse competence and intercultural competence.

- Linguistic competence

Linguistic competence refers to an intercultural speaker has the capacity to apply knowledge of the rules of the target language to successfully interpret and produce spoken and written language (Byram, 1997:48).

- Sociolinguistic competence

Sociolinguistic competence means to be able to not only deliver and express his or her message but also understand the language delivered by an interlocutor as well as the meanings behind it, no matter whether the meanings are expressed explicitly or hidden. In Byram's model, the interlocutor can be a native speaker or a non-native speaker of the target language (Byram, 1997:48).

- Discourse competence

Discourse competence deals with the ability to understand an interlocutor's strategies of interaction (following their own cultural conventions), negotiate one's own interaction strategies

with those of interlocutor, and to discover new strategies which facilitate a successful communication in an intercultural context (Byram, 1997:48).

Byram defined the above three sub-competences by refining the traditional term communicative competence. What makes Byram's ICC model stand out is the addition of intercultural competence (IC), which will be explained in detail in the following section.

- Intercultural Competence (IC)

Byram defines IC as the kind of competence which enables an individual, when engaged in intercultural communication, to be able to "decentre and take up of the others' perspective on their own culture, anticipating, and where possible resolving, dysfunctions in communication and behaviour" (Byram, 1997:42). Briefly speaking, IC is the ability to interact effectively with people from cultures that we recognize as being different from our own (Byram, 2004:297).

There are four sub-components of IC. They are: *knowledge*, *attitudes*, *skills* and *critical cultural awareness* (Byram 2009:323). Each sub-component is also known by a French term.

Knowledge (savours) includes "social groups and their products and practices in one's own and in one's interlocutor's country, and of the general processes of societal and individual interaction" (Byram, Nichols and Stevens 2001:6).

Attitudes (savoir-etre) include two main parts, namely, curiosity and openness to otherness (Byram, 2009:323), as well as "cognitive ability to establish and maintain a relationship between native cultures and foreign cultures" (Byram, Nichols and Stevens, 2001:56).

There are two types of skills. One is *skills of interpreting/relating (savoir comprendre)* which deal with the ability to interpret a document from another culture and to explain it, as well as to relate it to documents or events from one's own culture. The other type of skills refer to *skills of discovery and interaction (savoir apprendre/faire)*, which means the ability to acquire new knowledge of a culture and cultural practices, as well as the ability to access knowledge, attitudes and skills under the constraints of real-time communication (Byram, Nichols and Stevens 2001).

Finally, Byram defines *critical cultural awareness (savoir s'engager)* as "an ability to evaluate critically and, on the basis of explicit criteria, perspectives, practices and products in one's own and other cultures and countries." (2009:323)

As Belz (2007), citing Bredella, rightly points out, 'Byram is one of the very few scholars ... who extensively operationalizes the notion of intercultural competence in structured foreign language learning' (p.136). One main purpose of Byram's ICC model is to specify purposes and aims that

can be used in planning, teaching and assessment (Byram, 2009). Although the IC concept (with the more complex ICC model) provides a list of competencies as objectives for teaching and learning, there is no definition of levels or degrees of the competencies, or stages that one can go through to reach perfection. Furthermore, there is no relationship among the sub-competencies within IC or within the more complex ICC model (Byram, 2009:324-5).

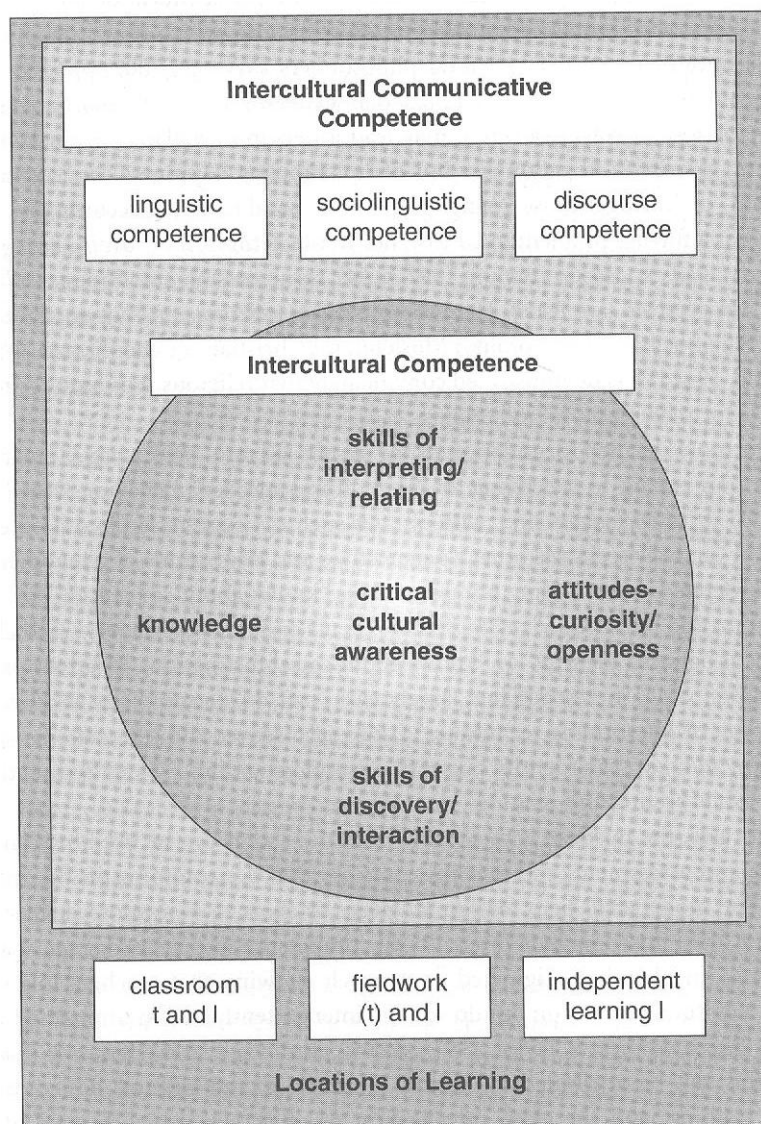

Fig 3.6 Intercultural Communicative Competence (Byram, 2009)

Although Byram developed his model with the concept of an intercultural speaker (ICS) and the focus of interpersonal (or face-to-face) communication in the intercultural context, the application of components of his ICC model, in particular intercultural competence, go beyond interpersonal communication. That is to say, based on Byram's ICC model, an interculturally competent individual who masters linguistic competence, sociolinguistic competence, discourse competence and intercultural competence, can conduct successful face-to-face and interpersonal

intercultural communication and is interculturally competent when interpreting cultural products (i.e. films or TV series) from different countries. As discussed in the first section in this chapter, as far as the nature of mass communication is concerned, the communication between a viewer and a media program (i.e. film) is one-directional and impersonal. This is significantly different from interpersonal and face-to-face communication with another individual.

Comparing all of the above models of intercultural competence with the purpose of current study, it seems that Byram's notion of intercultural competence (sub-competence of ICC) will be the most relevant.

Having reviewed the relevant literature on intercultural competence in ELT, as well as on mass communication and the effects of media programs (i.e. film, TV series) on audiences, the following section will analyze the literature on the use of films and TV series in ELT.

3.3 Films & TV Series in ELT

The purpose of this chapter is to review literature on the use of films and TV series in English language teaching (ELT) both in the Chinese context and non-Chinese context. However, first of all the definitions of a number of terms will be clarified.

- **Films and TV Series**

In terms of this literature review 'films and TV series' refer to films and TV series produced in English speaking countries which, in general, are viewed in the cinemas and/or on TV.

In the non-Chinese context, the majority of the literature deals with using films in ELT. Only few of them address the use of TV series, such as Jane Sherman (2003), Sert (2008), Goldman (1993) and Markham (2008).

Similarly, in the Chinese context, most of the literature discusses the use of films in college English classes. However, a number of teachers recommend several TV series which are beneficial for ELT. This will be further illustrated in the later part of this chapter.

3.3.1 Films in ELT: Non-Chinese Context

Stempleski and Tomalin (2001) have stated "for more than fifty years teachers have been using films both in and outside the language class" (p.2). As early as in the 1960s, films have been used as visual aids to help learners comprehend the literature (Bouman, 1996). Ever since the 1970s, ELT teachers have proposed the use of films in the English language classroom to help improve learners' English proficiency (St. Martin, 1978; Morley and Lawrence, 1972), including grammar (Ruhl, 1978), speaking and listening skills (British Council 1974; Chapple and Curtis, 2000),

vocabulary, reading, translation, (Mollica, 1978) and writing skills (Harris, 1983; Gex, 1982; Kasper, 2000; Flutt-Dupuy, 2001). In the early stage, some teachers believed that films were only suitable for advanced learners (Parker, 1976). With the advance of research and pedagogy, films have been used to assist learners at all language levels, ranging from elementary to advanced (Stempleski and Tomalin, 2001).

The following two sections will review WHY and HOW language teachers have used films to help learners improve their English proficiency.

A. Why films?

Entertaining and motivating

Many teachers believe that films are entertaining, motivating (Sherman, 2003), enjoyable (Holden, 2000) and relaxing, and are able to lower students' anxiety (Macdonald and Macdonald, 1991), hence increasing students' interest in class participation, as well as in learning English (Holden 2000; Shea 1995). The thrill of being able to understand the real thing (Sherman 2003) and the sense of achievement motivates students a great deal (Kirk, 1992). Hill (1999) even argues that films have great potential for motivating learners (Lin 2000a) at any stage of learning.

Authentic language input

It is believed that films provide authentic language input (Swaffar and Vlatten, 1997) which, compared to video made specifically for language learners, offers a variety of language (Lin 2000a) with much wider linguistic (Tasuki, 1992), paralinguistic and paragrammatic levels (Wood, 1999). Kirk (1992) values films as second only to native English language teachers. The language is up-to-date and interactive, with daily conversational exchange, different accents, vocabulary, grammar and syntax (Sherman 2003). Stempleski and Arcario (1992) emphasizes that films provide *real language*, in the sense that films are intended for native speakers. The language is ungraded and unsimplified, and is spoken at a normal pace and in typical accents. Also, the language is real (because it's current), and it makes use of idioms and expressions common in contemporary English-speaking environments.

Authentic culture input

Sherman (2003) believes authentic video (including films and TV series) is a "window on English language culture" (p.2) and the "second best thing after living and studying in (the) target cultural context. Authentic video helps to substitute for this experience; it brings the English-speaking-language world to the learner" (P.3) (Aiex 1988). Similarly, Macdonald and Macdonald (1991) believe that films are the next best thing to reality, because they display countless examples of problematical behaviour, conflicts and crushes, private lifestyles and casual speech. Such

authentic experiences, on which students can draw, are almost impossible to convey in class settings by other means, and are the next best thing to reality. Wood (1992) asserts that videos offer a multicultural and multilingual oasis which is essentially helpful when there is limited contact with those whose first language is English. Stempleski and Arcario (1992) hold a slightly different view. They suggest that films provide an authentic *look at culture*, in a sense that the films show how native speakers of English look at themselves. Hence, carefully chosen films can provide countless topics for cross-cultural discussion, enhancing students' awareness of their own culture in addition to that of natives who speak the target language. Holden (2000) interprets films as authentic input of foreign culture, in the sense that films are perceived as cultural products rather than reliable representations of the reality.

In addition, films' accessibility (Sherman 2003), as well as stimuli for language output (Katchen 1998), for example as a springboard for discussion activities (Conlon 1991; Holden 2000), appear to be two other advantages for ELT.

B. How to use films?

Debate: Whole film or clip?

In terms of integrating films into language classrooms, there has been a debate over whether to use whole film or to use clips (segments/excerpts) (Lin, 2000a).

The question of *time* has been one of the primary concerns about using whole films in the classroom. Most film scripts have about 120 pages, and one page roughly translates into one minute of a film (Jones and Jolliffe 2006). Hence, most films running time is about 2 hours, such as *Valentine's Day* (2009), which runs 125 minutes, and *Crazy Hart* (2009), which runs 112 minutes (IMDB 2010). However, the length of a film is quite genre dependent. Animations are usually about 90 minutes, such as *Princess and the Frog* (2009), which runs 97 minutes, whilst adventure films are usually somewhat longer than 2 hours. For example, the length of *Avatar 3D* (2009) is 163 minutes (IMDB, 2010).

Looking at the classroom context, the typical two-period class session is less than two hours. Things like getting the students settled and checking attendance consume some of this time. Therefore, many teachers advocate using short films clips, in order to make sure there will be more time for intensive and systematic language practice (Stempleski and Tomalin, 1990). In addition to clips being economical in provision of time for other activities, many teachers justify film clips as the incorporation of extra-textual materials that are motivational and enjoyable (Chiang, 1997 in Lin 2000a). Students can view the entire film at home or in the university multimedia centre instead of during the class session (Katchen 1998). The use of full-length films

is recommended in the role of a substitute or stand-in for a teacher who is unexpectedly forced out of the classroom by illness or emergency (Katchen, 1998).

However, the approach of using films clips is not without critics. A major criticism is that films, which are made for entertaining audiences, are meant to be experienced in their entirety. Film clips prevents the film from drawing the audiences into an emotional realm which is valuable to the overall goal of educating young adults (Shea, 1995). Students who enter the extended viewing experience after a period of careful and sufficient preparation are exposing themselves to “mass quantities” of comprehensible input (Krashen, 1982, cited by Shea, 1995). Students are also ready to recognize the “emotional and narrative dynamic of the video as a story about important things in human experience, aesthetic and ethical things like dreams, imagination, and commitment; things that drive language and ultimately stimulate students to learn it in the first place” (Shea, 1995). It seems that Shea’s point is that such an emotional interaction with the film simply cannot happen through a short clip.

Roles in class

In the language class, films are used either as visual aids to teaching (Bordwell 1969) or as supplementary materials (Aiex 1988; Colwell 2006) to the textbook (Stempleski and Tomalin 2001). On some occasions, films become the major instructional material (Lin 2002b). For example, Lin (2000a) developed a film-course entirely based on the film *You’ve Got Mail* (1998) to help develop college learners’ speaking and listening skills. Films have been found as the only course content in literature (Aiex 1988) and history classes (Rehborn 1987) as well.

C. Teaching approaches

For more than 50 years, films have been adopted by English language teachers to facilitate their teaching and achievement of educational outcomes (Bordwell 1969; Morley and Lawrence 1972; Brumfit 1990; Wood 1999; Kaye and Matson 2000; Sherman 2003; Glge 2008; Kuppens 2010). Several common film-based approaches will be reviewed below.

Linguistic-oriented approach

Many instructors elect to concentrate mainly on the linguistic features in a film, such as vocabulary, phonetic examples that it illustrates, discourse features (Wood, 1999), or grammar (Bardovi-Harling and Bergstrom, 1996). A linguistic-oriented approach (or language-only-approach) aims at enhancing learners linguistic competence (Visscher, 1990), including grammar (Rehborn 1987), in particular, tense (Bardovi-Harlig and Hergstrom 1996), and grammatical structures (Shea 1995), vocabulary (Parker 1976), including slang and idioms (Colwell 2006), listening (Stoller 1988; Han 1994; Holden 2000), speaking (Stoller 1988; Lin, 2002a), including fluency (Chapple and Curtis

2000; Donley 2000), speech skills (Katchen 1998) and accents (Colwell 2006), reading (Mollica 1978; Gex 1982), writing (St. Martin, 1978, Goldman, 1993) and academic writing (Kasper 2000). This approach has been applied in the classroom setting (Wood, 1999) at all language levels (Stempleski and Tomalin, 2001). In addition to linguistic competence, films have been used to help learners enhance their translation skills (Mollica 1978; Lin, 2002b). Among all these aspects, speaking and listening skills have been two main focuses for film-based-instruction (Stempleski and Tomalin, 2001).

However, the linguistic-oriented approach does not exist without criticism. Visscher (1990) questions the language-only approach and pointed out more potential of films in ELT.

Communication-oriented approach

In addition to linguistic competence, films have been used to help develop learners' communicative competence (Han 1994), communication skills (Holden 2000; Lin 2000b), pragmatic competence (Alicia 2007), non-verbal communication skills (Colwell 2006) and critical thinking skills (Lin 2000b), as well as motivation (Rebhorn 1987; Han 1994; Ryan 1998).

Comparing the above two approaches, the main difference is that the communication-orientated approach emphasizes not only linguistic competence, but also emphasizes students' ability to apply the knowledge and skills needed for successful communication.

Cultural approach

Another approach is a more culturally orientated approach. Conlon (1991) conducted a project which used the film *Witness* (1985) to develop students' listening and speaking skills as well as cultural awareness, particularly awareness of American culture and the criminal justice system. Griffin and Sherriffs (1994) propose using films to teach learners values. Wood (1997), apart from using films to help improve learners' linguistic and communicative competences, proposes several activities based on the film *Kramer VS Kramer* (1979) to lead to intercultural insights. Overall, activities at both pre-viewing and viewing stages seem mainly to enhance learners' vocabulary, listening and speaking skills, and at the same time ensure students' comprehension and understanding of the plot. According to Wood (1997), cultural activities at post-viewing stage can lead to intercultural insights, such as discussions among students on cultural differences they have observed, based on their understanding of the characters and their own culture (Japan, in this case). Alternatively, students can carry out an after-class-survey, in which learners research the situation in their own country with regard to issues raised by the film. The teacher can then facilitate collation of the information gathered in a class session, stressing the use of approximation to form an overall picture, while at the same time reminding students that the

results of an informal survey should never be considered as objective statements of fact. Often teachers will need to stop students from over-generalizing.

The outcomes of both Conlon's (1991) and Wood's (1997) approaches are more knowledge-based. Conlon focuses on increasing students' knowledge of one aspect of the target culture. On the other hand, Wood's intercultural insights mainly refer to students' knowledge of and understanding of characters in the film and the students' home culture, as well as differences and similarities between the fictional characters and their own culture. From another slightly different angle, O'Mara (1991) uses film to enhance students' understanding of intercultural communication.

Corbett (2003) suggests English language students can develop the intercultural skills of interpretation and critical awareness by using media studies techniques to analyze media texts (i.e. film and TV) in the language classroom. However, he fails to reference any concrete examples of teachers applying this approach, or any published research on the effectiveness of the approach.

In addition to above linguistic-oriented, communication-oriented and cultural approaches, some teachers use films as Friday afternoon relaxation (Stempleski and Arcario 1992). Last but not least, Stempleski and Tomalin (2001) suggest, in addition to linguistic competence, students can also learn film-making techniques.

D. Selection criteria

Although many scholars have discussed using films in ELT, very few have presented selection criteria in terms of what films to choose and how to choose. Stempleski and Tomalin (2001) suggests that in "in limited class periods, short film clips of two to five minutes are going to be more useful than longer sequences." (p.7). They also recommend keeping a good balance between appreciating the film and learning the language, because the prime reasons for watching film are entertainment and wonder. Sherman (2003) proposes the following 6 criteria. The film should be popular, interest learners, be visually attractive, and be linguistically easy. In addition, the film should avoid taboo subject matter, and the subject matter should be suitable for the age of the learners.

E. Teaching methods

This section reviews the literature on the applications of films in ELT classes. Although some instructors use full-length film (Conlon, 1991; Lin, 2000a; Sherman, 2003), whilst some others choose short film clips (Kaye and Matson, 2000; Stempleski, 1987; Stempleski and Tomalin 2001; Sherman, 2003), film-based activities generally mainly fall into three stages, namely, *pre-viewing*,

viewing, and *post-viewing* (Stoller 1988; Lin 2000b; Lin 2002a). Language instructors who are keen on using films for ELT, including Colwell 2006; Wood 1997; Katchen 1998; Bardovi-Harlig and Bergstrom 1996; Flutt-Dupuy 2001; Shea 1995; Stempleski and Tomalin 2001; and Sherman 2003, have designed a great number of activities for teachers to choose from. Due to the large number, they will not all be listed here. However, after careful review, a number of popular *types of activities* in each of the three-viewing stages have been identified by the author. They are presented in Table 3.1.

Stage	Type of Activity	Purpose
Pre-viewing	Cultural background introduction	Comprehension
	Film subject background	Comprehension
	Key vocabulary	Comprehension
	Pre-viewing questions	Comprehension
Viewing	Dictation	Listening, writing, vocabulary
	Imitation	Speaking
	Note-taking	Listening, writing
	Repetitive viewing	Listening skill, comprehension
Post-viewing	Character description	Speaking
	Comprehension check	Comprehension
	Debate	Speaking
	Dialogue completion	Listening, writing
	Discussion (comprehension, character, events, realism, music, ending)	Comprehension, interpretation
	Film review	Writing
	Film journal	Writing
	Intonation practice	Speaking, listening
	Anticipation of future events	Comprehension
	Role-play	Speaking, interests
	Re-tell story	Speaking
	Re-write script	Writing
	Study film script	Linguistic competence
	Transcription	Listening, writing
Vocabulary matching	Vocabulary	

Table 3.1 Film-based activities in the non-Chinese context

Although most of the activities are designed to assist learners' *comprehension* of the story and enhance their *linguistic competence*, a few have been identified to have a slightly different focus, which is more culturally driven. For example, *Culture Check*, the only one activity focuses on culture in Stempleski and Tomalin's book (2001), helps students analyse and discuss the view of their own culture portrayed in a film made in the U.K. or the U.S.A. Sherman (2003) proposes *Over the top* (p.207), which allow learners' to judge level of realism of the film. Another activity of Sherman (2003), *Picture it* (p.210), provides students with opportunities to discuss stereotypes and compare their expectations with reality.

F. Viewing techniques

The combination of audio and visual characteristics of films allows teachers to apply different viewing techniques to assist their teaching. Table 3.2 contains Stempleski and Tomalin's (2001) summary.

Types of viewing	Techniques
Normal viewing	Vision on/sound on
Silent viewing	Vision on/sound off
Sound only viewing	Vision of/sound on
Still-viewing	Pause/still/free-frame control

Table 3.2 Viewing techniques

Sherman (2003) proposes different ways of taking advantage of the fact that most of the DVDs offer soundtracks and subtitles in variety of language, such as the target language (L2) and the learner's mother language (L1). She suggests the techniques listed in Table 3.3 to help enhance learners' linguistic competence.

Techniques	Purposes
L1 soundtrack	Compare understanding with original L2 version
L1 soundtrack + L2 subtitles	Vocabulary extension
L2 Soundtrack + L1 subtitles	Check comprehension, translation exercises
L2 soundtrack + L2 subtitles	Transcribing script, improve comprehension, reading

Table 3.3 Use of subtitles

Although some scholars argue that there are differences between 'captions' and 'subtitles' (Screenfront. Ca, 2008 in Zarei, 2009), in the U.K. the term *subtitles* is usually used to mean both *captions* and *subtitles* (Zarei, 2008). The discussion here will adopt the same convention.

In the literature, there has been a debate on advantages and weaknesses of using subtitles in foreign language teaching (Zarei, 2009). Scholars who favour subtitles propose several merits of using subtitles. First, subtitles provide massive quantities of authentic and comprehensible input (Vanderplank, 1988:272-3; Borrás and Lafayette, 1994), and hence increase comprehension (Danan, 2004). Second, subtitled films may have potential to facilitate learners' vocabulary acquisition by encouraging learners to consciously notice new vocabulary and idioms (Wilson, 2002) and assisting learners' understanding of new vocabulary with simultaneous visual, textual and audio input (Baltova, 1999).

Several possible problems arising from using subtitles have also been raised. First, subtitles may be distracting and laziness may create a degree of dependence on the subtitles (Zanon, 2006). Second, viewers might rely on reading too much, which might not lead to better listening comprehension (Birds and Williams, 2002). King (2002) suggested several advantages of watching films without subtitles, such as developing high tolerance of ambiguity, enhancing listening strategies by guessing meaning from context and giving learners a sense of accomplishment and self-assurance.

Empirical studies have been carried out investigating effect of subtitling on foreign language learning (Zarei, 2009). Zanon (2006) concluded that subtitling (L2) could motivate learners to appreciate the content of the films to an extent that far surpasses that achieved when the film is presented to them dubbed (L1 soundtrack). Kusumarasdyati (2005) found subtitled film DVDs (*Bimodal subtitling*) is effective teaching device to enhance learners' listening skills. Borrás and Lafayette (1994) discovered that subtitles (*Bimodal subtitling*) enhance learners' comprehension of short video segments and learners' production of L2.

Another branch of empirical studies examines the effect of using different types of subtitles on vocabulary learning (Zarei, 2009). Koolstra and Beentjes (1999) found that television programmes with L2 soundtrack and L1 subtitles (*Standard subtitling*) help children learn vocabulary effectively. Neuman and Koskisen (1992) concluded that television programs with L2 subtitles are beneficial to learners' vocabulary recognition. Markham (1999) discovered that L2 subtitles improve learners' ability of aural word recognition.

A more recent study focusing on the effect of three types of subtitling on L2 vocabulary learning was conducted by Zarei (2009). Zarei adopted Zanon's categorisation of three types of subtitling (2006:47) which coincide with three common techniques of using subtitles proposed by language instructors and listed in **Table 3.3** above.

1. Bimodal subtitling: L2 soundtrack + L2 subtitles
2. Standard subtitling: L2 soundtrack + L1 subtitles
3. Reversed subtitling: L1 soundtrack + L2 subtitles

Among the above three types of subtitling, the study discovered that *Bimodal subtitling* proved to be the most effective for vocabulary recognition and recall due to the ‘combination of orthographic and phonological information’ Bimodal subtitling provides. *Standard subtitling* produced better results than *Reversed subtitling*. This might be because when the soundtrack is in L1, learners may not feel the need to read L2 subtitles, because comprehension is easily achieved without the subtitles. When learners do not read L2 subtitles, they do not learn new vocabulary productively (Zarei, 2009:82).

3.3.2 TV Series in ELT: Non-Chinese Context

Although the majority of the literature deals with the use of *films* in ELT, a few language teachers propose the use of TV series to help enhance learners’ linguistic competence, including reading (Markham 2008), writing, grammar (Goldman 1993), listening and speaking (Sert 2008). Zanon (2006) found that, accompanied by explicit instruction, the use of TV series may enhance students’ pragmatic skills. Similarly, Sert (2008) advocates using the British TV series *Coupling* (2000) to help improve learners’ awareness of figure of speech as part of everyday speech, which can be taught as part of communicative competence.

Although films and TV series are two different types of media texts, teachers seem to give similar reasons ‘why’ and similar approaches to ‘how’ to use them in ELT. One good example is Sherman (2003) who advocates the advantages of using and how to use authentic video. According to her, authentic video includes both films and TV series. All film-based and TV series-based activities can be used interchangeably. However, the only difference addressed is that film is a one-off story, whilst TV series tell a story over a longer period of time. In addition, each film lasts between 90 to 120 minutes, which is longer than one episode of a TV series (Sherman 2003).

3.3.3 Films in ELT: Chinese Context

The attitude of Chinese teachers towards using films for English teaching, and their implementation in classroom settings, will now be considered. Not surprisingly, many Chinese instructors perceive films as valuable resources for college English language teaching (Meng, 2009; Liu et al, 2009; Fang and Li, 2008; Shi, 2008; Zhang, 2008b).

The following two sections will describe WHY and HOW Chinese teachers have used films in the college English language teaching setting.

A. Why films?

Attractive and motivating

Films attract students because they tell complete stories (Dou and Wang 2001). Second, films are a form of art (Bo 2006a). Their vivid plots (Dou and Wang 2001; Bo 2006a) make them particularly interesting to learners (Huang 2009). Hence, during the past decade, many Chinese teachers have come to believe that films can motivate learners and increase their interest in learning English (Pan, 1999; Tang 2006; Fang and Li 2008; Yuan, 2009), and at the same time enliven class atmosphere (Zhang, 2009b; Zhu, 2009; Yang, 2009b).

Authentic language input and context

One of the most important reasons why Chinese teachers are keen on using films is the *language input*. The language itself has been widely recognized as being realistic (Zhao 2002; Long 2003; Chen 2007b; Ma 2009), authentic (Fang and Li 2008), clear and standard (Lan 2009), natural (Jiang 2009b) and rich (Cui 2006; Niu et al 2007). More specifically, film provides language with great varieties, such as accents and social class (Chen 2009a), dialects, vocabulary and pronunciation (Chen 2009b), syntax (Kang 2008), (地道的表达方法) authentic expressions (Shi and Li 2008) and 地道英语口语 authentic oral English (Tang 2006). Hence, some teachers believe that film is the next best thing to conversations with native speakers of English speaking countries (Zhang 2009b).

Lan's (2009) view is that films provide *standard* English. Similarly, Zhang (2009b) emphasizes that films provide *accurate* British and American English. Neither Lan nor Zhang give any further explanation on what is meant by standard and accurate English, and what English counts as standard and accurate.

In addition to the language itself, the context in which it is used has been recognized as another advantage of using films (Cui 2006; Chen 2009b). It is believed that films are close to life (Chen 2009a) and provide *realistic life scenarios* (Chen 2007b) and natural (Pan 1999) and realistic contexts of communication (Zhao 2002; Long 2003; Tang 2006; Ma 2009).

Apparently it is particularly important in the Chinese context that films provide both audio and visual messages, which make the language much easier for learners to understand (Dou and Wang 2001; Cui 2006), and allow learners to imitate the language (Chen 2007a).

Mirroring Western culture

Another main reason why films are favoured by Chinese instructors has to do with western-cultural-input, which is two-fold. First, it is widely accepted that films "realistically reflect cultural background" (Chen 2007b), such as society, history, nature, geography and custom in English

speaking countries (Bo 2006a; Tang 2006). Similarly, Yang (2009b) asserts “viewing an old American film is equal to living in the U.S.A. for ten days” (p.128). Zhao (2009) claims that films vividly and comprehensively ‘deliver’ another culture, including language, value, ways of thinking, lifestyles, etc. Hence, he describes teaching with film as the “most direct, realistic and accurate” approach to look at another culture. Similarly, Zhou (2009a) believes that films are the most direct reflection of a country’s social life and national culture, and hence that films are effective supplements for English teaching. Kang (2008) even describes films as “an encyclopaedia for life, culture and customs in English speaking countries” (p.135). Zhang (2009b) sees film as “a mirror which reflects the reality” (p.141).

In addition to the belief that films reflect culture realistically, some teachers look at films-as-culture-input from a slightly different angle. Huang and Liu (2009) and Long (2003) both argue that language is part of culture, and hence that studying language from film is a way of learning the culture. Shi (2008) believes that language and culture are so closely integrated that many films, in addition to being entertainment product, are “mirrors to western culture” (p.166).

Lan (2009) and Ma (2009) both claim films can help learners see cultural differences between the east and the west.

Good for teaching

Films are seen to be good for teaching as they tell stories which provide great variety of topics, and these can be used by teachers to assist their teaching (Chen 2007b). In addition, films can always catch students attention and keep them focused for long periods of time (Bo 2006a). Also, Wang (2001) suggests that films allow teachers to organize different kinds of activities in the class which effectively enhance students speaking and listening skills.

B. How to use films?

Whole film and clip

Chinese teachers use both full-length films and clips in the class. Tang (2006) proposes showing a whole film in the class just to give students a general understanding of the story. Dou and Wang (2001) suggests 15-minutes clips, whilst Zhang (2009a) prefers clips no longer than 3 minutes. Tang (2006) also favours clips for intensive or extensive language study.

Roles in class

Some teachers use films as supplementary material in the class. One common approach is to use clips from films which deal with the similar situations to those appearing in the textbook. In this

case films provide alternative and extra input on the same topic and subject as the textbook, and hence assist the students' learning (Jiang 2009).

On the other hand, sometimes films serve as the only course content. This type of course is usually named as *Film appreciation class (FAC)*. In many universities, FAC is neither a compulsory nor an optional course. Teachers simply show one or two films per term without any teaching activities arranged. Teachers usually sit at the back of the class and watch the films till the end with the students (Li 2003). However, this approach is not without critics. Niu et al (2007) believes that teachers should make better use of films.

C. Teaching approaches

Chinese teachers have been using films to assist their ELT for three or four decades (Pan, 1999, Yuan 2000; Zhao 2002; Cui 2006; Jiang 2009; Wang 2010).

Linguistic-oriented approach

Films have been used by Chinese English instructors to help learners enhance their linguistic competence, including speaking (Dou and Wang 2001; Long 2003; Gao 2008; Chen 2010), listening (Zhao 2002; Yang 2001; Bo 2006b; Zhou 2009a; Zhang 2009a; Chen 2010), writing (Lu, 2009; Bo 2006a) and reading (Dou and Wang 2001; Bo 2006a). Among these, speaking and listening are the two main focuses (Huang, 2009; Lan, 2009; Ou, 2009; Wu, 2009; Yang, 2009a; You, 2009).

More specifically, in terms of speaking, fluency (Liu 2005) and pronunciation (Kang 2008) are the main focuses. Yang (2009a) argues that using films helps develop learners' accurate British and American pronunciation.

Some teachers use films to improve learners' vocabulary (Ma, 2009; Wang 2009), including English taboo words (Tian, 2009).

Communication-oriented approach

In addition to linguistic competence, films have been used to develop learners' communicative competence (Bo 200a), because it is believed that films provide natural language context (Fang and Li 2008), as well as realistic communication scenarios (Li 2009).

Culture-oriented approach

Another approach is a more culturally oriented approach. Some teachers suggest using films to enhance learners' knowledge of western culture (Cui 2006; Fang and Li 2008) because films represent all aspects of life, custom, religion, history (Tong 2009) and culture of a nation directly (Zhou 2009a). Wang (2009) advocates the use of films for developing understanding on British and American culture because films deliver values, beliefs and emotions of English speaking

countries. Chen (2010) even argues that films reflect real life and are a window into western culture. Hence, learners can understand western culture better through films.

In addition, Fang and Li (2008) and Wu and Ma (2009) explain the value of films in terms of helping learners see cultural differences between the east and the west. However, it seems that what they meant by cultural differences has more to do with different ways of communication, for example the perception that Chinese are more direct than westerners.

Inter/Cross-cultural approach

Many Chinese teachers advocate using films to enhance learners' 跨文化交际能力 Kua Wen Hua Jiao Ji Neng Li (KWH) (Liu et al 2009; Zhang 2007; Gao 2008; Zhou 2009a; Chen 2009a), which can be translated into either cross-cultural communicative competence (CCC) or intercultural communicative competence (ICC). The Chinese character 跨 (Kua) literally means *cross*. One influential model of KWH proposed by Jia (1997) appears to be similar to Byram's (1997) concept of ICC. Hence, the term intercultural communicative competence (ICC) will be used in the rest of this section, which will look at what Chinese teachers have said about using films for KWH.

Li (2009) suggests that films can help learners not only improve their vocabulary, speaking and listening skills, but that they can also enhance students' ICC, because students can learn non-verbal communication. They can also learn more about British and American culture, as well as cultural differences between China and the West, such as ways of thinking. Li stresses gaining more knowledge of western culture and knowledge of the cultural difference between China and the West in a general sense. Therefore, it can be speculated that the concept of ICC in Li's mind is more knowledge-based. Ma (2009) also has high confidence that films can help improve learners' ICC, because students can see cultural differences between China and the West. What Li and Ma share is that of *knowing-cultural-differences* between China and the target country. Ou (2009) also stresses the importance of knowing cultural differences between China and the West for successful intercultural encounters. Xiao (2009) expresses the need for Chinese learners to improve their ICC. According to Xiao, one main reason why learners' ICC is underdeveloped is because they don't know enough about western culture. Xiao then indicates that using films is an effective way for teaching cultural knowledge. Yang (2009b) proposes that films which deal with the theme of cultural conflict, such as "*Crash* (2004) can vividly and directly reflect western culture, and help students understand cultural differences between Chinese and the West. Students can better understand different ways of thinking and different values between the West and China through the development of the plot and the story of the films, and hence develop their intercultural communicative competence" (p.128).

Looking at what is said above about using films to enhance learners' ICC, we can find some things in common. First, film is widely recognized as valuable resource for improving students' ICC in the English classroom in the Chinese context. Second, teachers who recommend use of film did not give a clear definition of ICC. It seems that what they mean is that ICC consists of two parts, linguistic competence and cultural knowledge (which includes knowledge of western culture and knowledge of cultural differences between China and target country). Hence, the concept of ICC in Chinese teachers' minds is different from the ICC concepts proposed in the West (e.g. Byram's ICC).

In terms of cultural knowledge, Tong (2009) suggests using films to teach religion, history, art and literature. Wu (2009) proposes using films to help learners to develop their communicative competence.

D. Selection criteria

In comparison with the literature existing in the non-Chinese context, there is more discussion in the Chinese literature concerning selection of suitable films for ELT.

Learners' English proficiency

In order to ensure comprehension, it has been suggested that the language should not be too difficult (Fang and Li 2008). Teachers should choose films according to learners' English proficiency (You 2009). More specifically, Bo (2006a) suggests films produced by Walt Disney are more suitable for lower level students. Similarly, Huang (2009) recommends cartoon films for first-year students. However neither Bo nor Huang give further justification for their criteria.

Good films

Jiao and Gao (2009) suggests choosing good films which contain clear pronunciation and provide rich language and cultural background. Lu (2009) and Yang (2009b) recommend recent award-winning films, because they are up-to-date and are more attractive to students. At the same time, the language is well polished. Although Lu and Yang did not give any further explanation on what they meant by polished language, it can be speculated that the concept is similar to that of *accurate, standard* English, which repetitively appears in the Chinese context. Tang (2006) reminds teachers to make sure the picture is clear.

Film language and plot

Some teachers propose several language-related factors to keep in mind when choosing films. It is widely accepted that the film should contain rich language (Niu et al 2007; Li 2009; You 2009), which contains a large amount of dialogue (Lu 2009; Yang 2009a). Ma (2009) and Zhao (2002) have slightly different view. They propose choosing films which contain simple dialogues.

In addition to language, Chen (2007b) and Fang and Li (2008) propose choosing films with interesting plots. Ma (2009) reminds readers that the plot should be simple.

Film genre

Zhou (2009a) suggests using films in different genres, such as drama, comedy and science-fiction. However, Zhou does not provide any justification of her criteria. Lan (2009), on the other hand, proposes to avoid cartoons because the language in cartoon films, in particular the pronunciation and intonation, is very exaggerated. Zhou (2009a) believes war films are not suitable for ELT use, because war films normally do not contain rich dialogues. Plus, the background music is so loud that it may disturb students listening to the film.

Close to life

Some teachers recommend choosing films that are close to life (Bo 2006a; Chen 2007b; Li 2009; You 2009). Niu et al (2007) suggests choosing films which reflect reality. Bo (2006a) and Fang (2008), on the other hand, favour films which reflect the cultural background in different periods of time. However, none of above authors give any further suggestions or indicators that can be used to evaluate films in terms of how they are close to life, or reflect reality or the target cultural background.

Healthy content

Many teachers emphasize the importance of choosing films which have positive (Fang and Li 2008; Lu 2009) and healthy content (Dou and Wang 2001; Chen 2007b; You 2009). Avoidance of the sections which portray sex and violence is recommended (Lu 2009; Yang 2009b), in case students get distracted from learning knowledge or their mentality is affected negatively.

You (2009) suggests choosing films which are beneficial for helping students' develop a "correct" philosophy of life, as well as films which can help students interpret western culture from a "correct" perspective. The concept of correctness seems to be the key argument, but, You does not give any further clarification.

Teaching aims

Last but not least, for those teachers who use films as supplementary material, it is recommended for teachers to bear lesson aims and teaching needs in mind when choosing films (Chen 2007b; Tang 2006).

E. Teaching methods

In terms of teaching, it is suggested that a teacher's preparation before the class is vital, because films are rich in language and cultural resources, especially foreign English films (Dou and Wang

2001). In terms of preparation, Niu et al (2007) suggests to prepare a workbook beforehand in order to help learners with their comprehension and with their class-room activity participation.

Stage	Types of Activity	Purpose
Pre-viewing	Cultural background	Cultural knowledge, comprehension
	Difficult language	Comprehension, vocabulary
	Film background	comprehension
	Main characters	Comprehension, interests
	Plot summary	comprehension
	Pre-viewing questions	comprehension
Viewing	Repeat after character	Pronunciation, intonation
	Comprehension questions	comprehension
	Dictation	Listening, writing
	Note-taking	Listening, comprehension
	Speed-reading (subtitles)	Listening, reading
	Information-gap	Comprehension, listening, writing
Post-viewing	Debate	Speaking
	Dialogue completion	Comprehension, writing
	Dialogue memorization	Speaking
	Dictation	Listening, writing
	Discussion (characters, incidents)	Comprehension, speaking
	Film review	Comprehension, writing
	Plot summary	Comprehension, Writing
	Re-write film script	writing
	Role-play	speaking
	Story-telling	Comprehension, speaking
	Translation	translation
	True or False	Comprehension

Table 3.4 Film-based activities in the Chinese context

(Chen 2007b; Yuan 2000; Pan 1999; Huang 2009; Lu 2009; Niu et al 2007; Zhou 2009a; Li 2003; Yang 2009b; Lan 2009; Jiang 2009b; Wang 2001; Dou and Wang 2001; Long 2003)

The rest of this section will review popular types of film-based activities in the Chinese ELT context in the past decade, which generally fall into three stages, *pre-viewing*, *viewing*, and *post-viewing* (Long 2003; Chen 2007b; Lu 2009). This three-stage approach (Table 3.4) coincides with film-based activities in the non-Chinese context (Table 3.1).

Like activities in the non-Chinese context, most of the activities are designed to enhance students' comprehension and development of linguistic competence. This means that although many teachers discuss using films to develop learners' linguistic competence and ICC, most of the activities are still language-oriented. However, the activities that address cultural knowledge and ICC tend to take place in the post-viewing stage in the form of film-review. In the pre-viewing stage, the only type of activity which touches upon culture is *Cultural background* activity.

Viewing techniques

Chinese teachers also make use of audio-visual characteristics of films. Several viewing techniques are listed in Table 3.5 (Bo 2006a; Tang 2006).

Types of viewing	Techniques
Normal viewing	Vision on/sound on
Silent viewing	Vision on/sound off
Sound only viewing	Vision of/sound on
Still-viewing	Pause/still/free-frame control
Repetitive viewing	View chosen clip again and again

Table 3.5 Viewing techniques

Two scholars mention the use of subtitles (Zhao 2002; You2009), as listed in Table 3.6.

Techniques	Purposes
English soundtrack + Chinese subtitles	Listening, comprehension
English Soundtrack + English and Chinese subtitles	Listening, comprehension

Table 3.6 Use of subtitles

Teaching difficulties

Chinese teachers have encountered two main difficulties when using films in ELT. First, due to the fact that there are a fixed number of classes each term and teaching with film needs time, not having enough time is one common difficulty. Second, it takes a lot of time to prepare a class which involves the use of films, because films contain variety of subjects and rich cultural discourses (Tang 2006).

Recommended films and TV series

Table 3.7 shows films and TV series which have been recommended by Chinese teachers for College English language class during the past decade. TV series are highlighted in grey.

Film/TV Series	Teaching Purposes
American Beauty (1999)	Emotional world of confused Americans (Wang 2009)
	Different kinds of problems in American society (Xiao 2009)
Brave Heart (1997)	History and war in Scotland. Let students feel real history (Zhou 2009a)
Casablanca (1942)	English for college learners (Zhou 2009a)
Crash (2004)	Multi-ethnic culture in the U.S.A. (Xiao 2009) Western culture and cultural differences (Yang 2009b)
Dances with Wolves (1990)	The process of American government opening up the West. Indians innocence (Huang 2009a)
Finding Nemo (2003)	Beginner listening (Bo 2006a)
Forrest Gump (1994)	American cultural background (Bo 2006a)
	Natural and common English (Yang 2009b)
	American social problems, such as Jenny's father's sexual abuse (Cui 2006)
	Philosophy of life (Huang 2009a)
Gladiator (2000)	Key historical incidents in America (Wang 2009; Zhou 2009a)
Gladiator (2000)	Western culture; History (Tong 2009)
Friends (1994-2004)	American culture; Thanks giving, Halloween, Christmas (Chi 2009)
	Speaking, pronunciation (Kang 2008)
Gone with the wind (1939)	Vocabulary, syntax, intonation, American culture, civil war, ICC (Bo 2006a)
Growing Pains (1985-92)	Listening (Zhu and Wang 2008)
Gua Sha (2001)	Western and Asian cultural differences and conflicts (Yang 2009)
Ice Age (2002)	Language for beginner (Li 2009)
King Lear (1983)	Speed reading for advanced learner (Bo 2006a)
Kongfu Panda (2008)	Beginner English (Li 2009)
Lion King (1994)	Speed reading for lower level learners (Bo 2006a)
Pride and Prejudice (2005)	Different people's value on love. Ways of dressing in different occasions (Chen 2007a)
Roman Holiday (1953)	Language (Yang 2009b)
Sex and the City (1998-2004)	Western career women's city life (Liao 2008)
Sound of Music (1965)	Language characters of people in different ages and occupations (Chen 2007a)
Waterloo Bridge (1940)	Language for college learners (Zhou 2009a)
Working Girl (1988)	Business English (Niu et al 2007)

Table 3.7 Films recommended by Chinese teachers of English

Old films, such as *Sound of Music*, *Roman Holiday* and *Casablanca*, are recommended by some Chinese teachers, because they believe that the language in old films is clear and slow, which makes it good supplementary material (Yang 2009b; Zhou 2009a). However, Zhu and Wang (2008)

think *Casablanca* is not good material for listening practice because the language is too old and not up-to-date.

3.3.4 Summary

This section has reviewed the use of films and TV series in ELT in both the Chinese and non-Chinese contexts. Looking at the literature, several similarities and differences have been identified between the two contexts.

A. Similarities

First, films are widely recognised as a valuable resource for ELT due to their unique advantages, namely providing *language-input*, *entertainment*, *motivation* and *culture-input*. Although there is little literature about TV series, the reasons why they are beneficial for ELT are more or less the same as film. Film-based and TV-series-based activities can be used interchangeably.

Second, films and TV series, and in particular films, play two different roles in educational setting. Most instructors use them as supplementary material to a textbook. Some teachers design film-based course in which films are used as the only material.

Third, most of the time, teachers use films and TV series for development of learners' linguistic competence. Although communication-oriented and cultural-oriented approaches have been identified, a linguistic-oriented approach is the most dominant one, especially in the Chinese context.

In addition, the three-stage-viewing technique is widely applied in both the International and the Chinese contexts. Activities fall into three stages, namely pre-viewing, viewing and post-viewing. Teachers are aware of the value of subtitles in both the learners' first language and second language. Attempts have been made to make use of the combination of subtitles, soundtracks, sound and the picture.

Finally, both full-length film and short-clips have been used in the classroom settings. There has been a debate in the non-Chinese context. In the Chinese context, the main concern about using full-length film is the amount of time it requires.

B. Differences

Through this review, we can identify six major differences between scholars inside and outside China in terms of their perceptions and attitudes regarding film use in the ELT classroom. First, although *language-input* has been recognized by teachers in both contexts as one of the advantages of films and TV series, it seems that, comparatively, Chinese teachers specifically

emphasize *realistic, standard, accurate and common* English, as well as the *context* in which that language is used.

Second, although *culture-input* is recognized as another advantage of films and TV series in both contexts, views on the nature of the culture-input vary. In the non-Chinese context, the views range from one extreme, that films brings the reality to learners (Aiex 1988), to another, as Holden (2000) suggests that people find the films interesting rather than films realistically reflect the reality of the target country. However, in the Chinese context, it seems that instructors share a fairly unified view that films and TV series realistically reflect the reality in English speaking countries. This view is similar to that of Aiex (1988) in the non-Chinese context.

Third, in terms of the nature of culture-oriented teaching approaches, in the non-Chinese context instructors' approaches are more knowledge-based, both in terms of knowledge of target culture, and in terms of knowledge of differences between fictional characters and the learner's own culture. However, in the Chinese context, instructors' approaches are two-fold. One is knowledge-based, in the sense of knowing more about target culture and cultural differences between the West and China. Second, in the literature from 2007 onwards, many Chinese teachers advocate using films to develop students' intercultural communicative competence (ICC). However, although those teachers did not give clear definition on what they mean by ICC, literature shows that the concept of ICC in their mind is different from Byram's ICC notion. Chinese teachers' concept of ICC seems to include three main components, namely, linguistic competence, social linguistic competence, and cultural knowledge. The first two components seem to overlap with two sub-competences (linguistic competence and social-linguistic competence) of Byram's ICC model. The third component, cultural knowledge, which includes knowledge of the target people and country, as well as of differences between self and others, seems to be similar to the 'knowledge (Savours)' in Byram's IC model. However, Chinese version of ICC emphasizes knowledge on target country more, whilst Byram emphasized knowledge of both self and other.

Fourth, in terms of selection criteria, it seems that Chinese instructors have longer lists with slightly different emphasis to teachers in the non-Chinese context. However, they do have some criteria in common. For example, chosen films or TV series need to be attractive to students. Also, the learner's language proficiency is another factor to keep in mind, because it is believed that learners will get put off if the language is too difficult to understand. The subject matter and age appropriateness are another two factors proposed in the non-Chinese context. Similarly, a number of Chinese teachers remind readers to avoid violent and sexual scenes. Although age appropriateness is not mentioned by Chinese teachers, the criterion of healthy content indicates that teachers will need to choose the content which is appropriate for learners in their age. In

terms of *healthy content*, there is another layer of meaning which refers to the content that will help learners develop correct philosophy of life and correct interpretation of western culture. This concept of correctness-related-criterion seems to be culturally specific. Another culturally specific criterion has to do with the concept of good films, which according to some Chinese teachers are the recent award-winning films, because they provide polished and up-to-date language. It seems that the concepts of *authority* and *standard* play an important role in Chinese teachers' teaching pedagogy and classroom implementation. What is more, some Chinese teachers recommend several genres suitable for ELT, namely drama, comedy and science-fiction. However, no justification is provided. Interestingly, some teachers recommend cartoons for beginner level students, whilst one teacher Lan (2009) thinks the opposite, because cartoon language is too exaggerated. Another important criterion provided by Chinese teachers has to do with reflecting-reality and reflecting-culture. However, whether or not a film or TV series reflect cultural background or reality is a subjective matter. Last but not least, it is suggested in the non-Chinese context short-film clips of two-to-five-minutes are suitable for classroom use, whilst no such recommendation has been made in China.

Turning to classroom-implementation, although instructors in both contexts follow the same three-stage-viewing procedure and share many over-lap types of activities, some activities in each stage vary. Comparing both contexts, several types of activities are seem to only exist in the Chinese context, and they appear to be linguistic-oriented, such as *Speed reading* (subtitles), *Information-gap*, *Dictation*, *Dialogue memorization* and *Translation*. Also, at the pre-viewing stage, two types of activities are used by Chinese teachers only, namely, *Main characters* and *Plot summary*. These two activities serve the same purpose, to assist learners' comprehension by introducing main characters and providing a plot summary produced by the teacher before viewing. Although instructors in both contexts propose activities which are culturally driven, the number of this type of activities compared to linguistic-oriented activities is very small. Especially in the Chinese context, only two types of activities touch upon culture, namely, *Cultural background* (pre-viewing stage) and *Discussion* (post-viewing stage). The *Cultural background* activity mainly serves the purpose of helping learners gain more knowledge of the target culture in order to better understand the film. In terms of the *Film review* activity, teachers ask students to write whatever they want to write about after viewing the film. Sometimes teachers will ask students to share their reviews with other students in the class. However, the description of this activity is very general, with no follow-up action described.

Finally, in terms of using films and TV series for ELT, difficulties have been raised by Chinese teachers. One is the limitation of time. The other one is that teachers need a lot of time to do

plenty of preparation before the class, due to the fact that the films and the TV series produced in English speaking countries are foreign and culturally specific.

3.4 Conclusion

Now, let us pause and picture a group of Chinese students sitting in a language classroom watching *Harry Potter*⁹. All students' attention is fully focussed on the moving pictures, plot and the sound from the big screen. They watch the western actors act and listen to them talking in English.

Do they understand this foreign film? Do they share the same understanding as each other? Do they enjoy watching it? Is there anything else going on in their minds? Does the film make them believe this is how British students live?

Having reviewed the literature on mass media communication process, audience reception (Hall's encoding and decoding), and media effects on audience, what is going on between this film and the Chinese students in above scenario is clearly a complex communication process between Chinese audiences and foreign cultural product. However, this process has often been perceived by the teachers simply as one-directional and linear with unified interpretation. In the current research context, the communication is between English films or TV series produced in the U.K. and U.S.A. and Chinese college students, for whom English is a foreign language.

Bearing this in mind, let us re-examine how the ELT instructors have been using films and TV series in the ELT classrooms. It seems that ELT instructors, both in the Chinese and non-Chinese contexts, have generally assumed that films can help students improve their English and knowledge on target culture. Although the literature quotes many advantages of using such media in ELT classrooms, the empirical evidence for the effectiveness of the approach is limited. Secondly, the vital stage of how students make sense of film is ignored. Teachers, especially in the Chinese context, seem to assume students will learn what they want them to learn. In other words, students will understand and share a unified interpretation of the film which will be the same as the teacher's. However, it is clear at this stage that this assumption needs to be at least questioned and subjected to empirical investigation.

Hence, by looking at audiences watching foreign films and TV series on a micro-level, in particular Chinese college students viewing English films, and discovering how they make sense of these foreign fictional programs, the author expected to make useful findings relating to the use of films

⁹ Harry Potter: full name of this film is *Harry Potter and the Philosopher's Stone* (2001). This British film is about a young boy, Harry Potter, who was rescued from the outrageous neglect of his aunt and uncle. With a great destiny, Harry his worth while attending Hogwarts School of Witchcraft and Wizardry.

in ELT, and particularly relating to the goal of ELT from an intercultural perspective in the Chinese context, both theoretically and pedagogically.

The next chapter will discuss the research questions, the methods that have been applied in the current research and the data analysis techniques used.

Chapter Four: Empirical Study, Research Questions and Methodology

“The whole research journey, from initial planning, design, pilot, field work to data analysis, has been a real reflexive and learning experience for me.” (My note on the 5th November 2009)

The preceding chapter has provided a detailed analysis of the complex nature of communication between media programs and audience, media effects, and intercultural communicative competence in ELT, as well as the use of foreign films and TV series in ELT both in the Chinese and non-Chinese contexts. Although a significant number of ways to use foreign films in the ELT classroom setting have been suggested by English instructors, empirical research focusing on how students actually make sense of the foreign fictional programs that they view was found to be limited.

As mentioned before, the main aim of the current empirical research is to explore how films and TV series, in particular those produced in the U.K. and the U.S.A., can be better used in the Chinese higher education context from an intercultural perspective. By investigating and examining how Chinese college students make sense of the programs that they watch, it is hoped that the findings will have valuable theoretical and pedagogical implications for the use of foreign English films and TV series in College ELT in China. The empirical research was conducted in several universities in China.

This chapter considers the research questions, the design of the empirical study, the data collection process and the data analysis techniques adopted in this study. After addressing the research questions, the design of the two tools used to gather the empirical data, namely the questionnaire and the semi-structured interview, are considered. Ethical issues are then discussed, followed by a detailed description of the pilot studies and the main fieldwork and data collection. Issues of validity and reliability of the data are discussed. Finally the techniques employed in analysing the data are described.

4.1 Research Questions

The following six research questions were designed to provide answers which would allow the main research objective of this study to be achieved.

- RQ1: From which resource do Chinese college students (CCSs) think they learn the most about the people and cultures of English speaking countries, in particular the U.K. and the U.S.A.?

- RQ2: What type(s) of media do CCSs prefer to use in order to learn about people and cultures of the U.K. and the U.S.A.?
- RQ3: How do CCSs make sense of films and TV series produced in other cultures, specifically films and TV series produced in the U.K. or U.S.A? (core question)
- RQ4: Are there any discernible effects of foreign film viewing on CCSs' understanding of and attitudes to other peoples and cultures? If so, what are they?
- RQ5: What is the current status of using English films and TV series in ELT classroom?
- RQ6: What are the theoretical and pedagogical implications for English teachers in the Chinese context?

Research Question (RQ) 1 and RQ 2 are designed to obtain a broad and general picture of *what is going on* in the Chinese context. To be specific, it is hoped to find out, from CCSs' point of view, how important the films and TV series produced in the U.K. and the U.S.A. are as resources for the CCSs in terms of learning about the two countries, including people, culture etc. Also, among all types of resources available, whether CCSs *prefer* to use films and TV series when they want to learn more about the U.K. and the U.S.A.

RQ 3 is a core question. As discussed before, existing research on audience reception shows that the communication between the media program and the audience is a complex process. Empirical research on how Chinese audiences make sense of foreign English language media programs is almost non-existent. Hence, RQ 3 aims to provide an in-depth understanding of how CCSs make sense of the films and TV series produced in the U.K. and the U.S.A. from an intercultural perspective.

RQ 4 aims to find out whether CCSs are influenced by the programs that they watch. More specifically, whether CCSs gain more knowledge of the people and culture of the U.K. and U.S.A., and whether their existing understanding, attitudes or view changes as a result of viewing the films and TV program produced in these two countries.

RQ 5 aims to look at the use of films and TV series in ELT *inside* and *outside* of China. RQ 5 has been answered in the previous chapter (section 3.3). The empirical research performed in this study provides supplementary data on the current approaches to using films and TV series adopted by research participants' instructors in college English classes.

RQ 6 looks at the theoretical and practical implications of the current study, and will be discussed in the discussion chapter.

4.2 Research Methodology

“Fitness for purpose has been the guiding principle throughout my research method design.” (My note on 17th June 2007)

A mixture of quantitative and qualitative methodologies has been adopted for this empirical research. Mixed methods of this kind, which have been frequently used to research similar phenomena (Bryman 2004), are not only able to gather and analyse generalizable data, but also to carry out in-depth investigation to look at a fraction of the participants more closely (Basit 2010).

Given the research questions, it was considered appropriate to focus on questionnaire surveys and semi-structured interviews, as this approach has been found to be able to produce both quantitative and qualitative data, with the latter providing access to what is inside the subjects' minds (Tuckman, 1994:216). The sections below describe the design of the questionnaire and the semi-structured interviews.

4.2.1 Questionnaire

Questionnaires are the most widely used and useful instrument to collect quantitative data providing a general picture of the research phenomena (Wilson and McLean 1994; Cohen et al, 2007; De Vaus, 2002: 94; McMillan and Schumacher, 1997: 252). Questionnaires offer considerable advantages in administration, allowing access to large numbers of people simultaneously (Basit 2010).

In the literature, three basic types of questionnaire are normally recognized. They are *structured*, *semi-structured* and *unstructured* questionnaires. The current research used a semi-structured questionnaire, because, as Cohen et al (2007:321) identify,

between a completely open questionnaire that is akin to an open invitation to “write what one wants” and a totally closed, completely structured questionnaire, there is a powerful tool of the semi-structured questionnaire (...) the researcher can select several types of questionnaire, from highly structured to unstructured.

In the questionnaire, closed- and open-ended questions are used. The reason why most of the questions are closed questions is because of the straightforward data required. Also, closed questions are quick to complete (Basit 2010), which avoids the students becoming bored and impatient, and ensures a good return rate. In addition, closed questions are straightforward to code and “do not discriminate unduly on the basis of how articulate respondents are” (Wilson and McLean 1994:21). Several open-ended questions are included in the questionnaire. This is because closed questions do not enable respondents to add any further remarks and comments, which can create problems if the categories are not exhaustive or have bias in them (Oppenheim

1992:115). Open questions enable participants to provide responses in their own terms, avoiding the limitations of pre-set categories of responses (Cohen et al 2007).

During the process of the questionnaire design, a considerable amount of effort was made to incorporate several essential elements of a well-developed questionnaire, namely layout, clarity of wording, simplicity of design, clear instructions and assurance of confidentiality and anonymity (Cohen et al 2007). In order to convey the aim of the research and the importance of the research, to provide assurance of confidentiality and to encourage respondents' replies, a covering letter was included. Cohen et al (2007:339) provided a list of items which should be taken into consideration when preparing a covering letter, and this list was very helpful.

The questionnaire was made available in both Chinese and English, in order to ensure respondents had the opportunity to choose whichever language they preferred. The English version is reproduced in Appendix 1 and the Chinese version in Appendix 2.

The questionnaire contains five parts. Each part includes several questions. Parts one, two, three and four were designed to answer Research Questions 1 and 2. In addition, findings from these four parts would provide useful information for the later semi-structured interviews. The final part of the questionnaire, part five, aimed to produce a list of films and TV series that, from CCSs' views, helped them learn about the U.K. and the U.S.A. This part was not essential in terms of answering any empirical research questions, but it was useful in terms of helping the author prepare the interview sub-questions and choice of clips, as well as appropriate prompts and probes.

During the process of developing the questionnaire in both languages, it was not always possible to find equivalent words to express the same meaning in both languages. Just as Berreman (2004) said:

People of different cultures and different languages categorize their experiences and the world around them differently, and they verbalize them in different ways. Literal translation of words for objects, ideas, attitudes, and beliefs is often impossible.
(pp.184-185)

For example, question 3 in part three asks respondents to choose one number from 1 to 5 to indicate to what extent they believe they have learned about the two countries from listed resources. In order to avoid the ambiguity of the degree each number represents, one phrase was attached to each number to give uniform understanding. However, I found that it was extremely difficult to find equivalent English words which deliver the exact same meaning as the Chinese words chosen, even after consulting another bilingual academic expert. Hence, bearing the *fitness*

for purpose principle in mind, I chose not to translate those phrases and kept the Chinese phrases in both English and Chinese questionnaires.

Part five of the questionnaire contains a list of films and TV series. It was important to ensure that this list contained most of the films and series the CCSs would have watched. I developed the list from several main resources, including the Internet Movie Database (IMDB)¹⁰, my own personal experience of being a movie-buff for many years, feedback from some friends who were still undertaking undergraduate studies in China, as well as from my supervisors. Among these resources, IMDB and my personal experience and knowledge played the most important roles.

I made the selection of films included in the list based on several criteria. First, the films and TV series should be ones that are likely to have been watched by current CCSs. Second, the list should contain material from a number of eras, including films and TV dated from as early as 1930s. This is because films such as *Modern Times* (1936), *The Wizard of Oz* (1939), *Gone with the Wind* (1939), are the earliest films that were imported to China. They are now viewed in China as absolute classics, in particular *Modern Times* and *Gone with the Wind* (both in cinema and literature). Hence, although these films were made 70 years ago, it was not a surprise to me that some of the CCSs had seen those films. In addition, the style, story-line and topics of films and TV series vary as time goes by. It was possible that CCSs might view old and new films differently. The third criterion was that the list should contain programs of all genres¹¹. This is because genre is one of the key elements people use to decide what program to watch. Also, it was possible that people make sense of programs in different genres differently.

Following the above criteria, I did extensive research using IMDB. Ideally, a similar database produced in China would have been the best resource to help me produce the list, but there was none available. IMDB is long-established and comprehensive movie-database. Hence, it was considered IMDB was the best resource available.

During the selection process, the *popularity* of a film or TV series was the most important aspect. It was assumed that the more popular a film was, the more influential it was internationally, and hence the more likely that it had been viewed by the CCSs in China. Hence, I made use of the on-line voting system provided by IMDB. All the films had been voted on by on-line IMDB users worldwide. I collected top films voted by genre, top films voted by decade, and all-time box office receipts (U.S.A., non-U.S.A., World-wide). After that, based on my experience and knowledge, I

¹⁰ The Internet Movie Database (IMDB) is 'an online database of information related to movies, television shows, actors, production crew personnel, video games, and most recently, fictional characters featured in visual entertainment media. IMDB launched on October 7 1990, and in 1998 was acquired by Amazon.com (Wikipedia, 2010)

¹¹ Types of genres: action, adventure, animation, biography, comedy, crime, documentary, drama, fantasy, history, horror, independent, music, musical, mystery, romance, Sci-fi, Short, sport, thriller, war, western (IMDB: 2007).

chose the ones which are most likely to have been seen by CCSs. I also used the on-line search engine 'Google' to help me identify whether certain films or TV series had entered Chinese market (including both the ones imported by the Chinese government and the pirated ones on the black market).

In case any important films or TV series were missed out of the list, part six in the questionnaire gave CCSs opportunities to write down any other program they had watched and felt had influenced them.

Like all types of research methods, using a questionnaire has advantages and disadvantages. On the one hand, a questionnaire has some merits in comparison to using interviews. For example, it is cheaper and quicker to administer, avoids interviewer bias and effects, and is convenient for respondents (Moser 1958, Wilson and McClean 1994, McMillan and Schumacher 1997, Bryman 2004). On the other hand, a questionnaire cannot probe and prompt, ask follow-up questions or collect additional data. Also, compared to interviews, there can be a low response rate, and respondents might reply according to social desirability rather personal willingness (Moser, 1958; Oppenheim, 1992; Bryman 2004).

Having explained the design of the questionnaire which answers the Research Questions 1 and 2, the following section will discuss the use and design of the complementary semi-structured interviews that answer Research Questions 3 and 4.

4.2.2 Semi-structured Interview

Interviews are one of the most popular methods of gathering qualitative data for social science researchers (Basit 2010). Interviews have many advantages. For example, interviews are not only able to reveal and explore the research subjects, but also allow researchers to conduct in-depth focused study on specific issues and themes (Cohen et al 2007). Kitwood (1977) (in Cohen et al 2007) believes that a well-conducted interview, with respondents being sincere and well-motivated, may obtain accurate data. Unlike questionnaires, interviews always allow face-to-face interaction, which is helpful for trust and building cooperation between the researcher and respondent (Dooley 2001). In addition, the interviewer can be flexible (Bailey 1994), is able to clarify comments from the respondents, and can stimulate the respondent to give richer and full answers (Robson 1993). In addition, in an interview, any unexpected results from the questionnaire can be followed up in order to gain deeper understanding of the participants (Kerliner 1970).

Hence, the use of interviews has been identified as an appropriate method to answer Research Questions 3 and 4. Among the three available types of interviews, namely structured-interviews,

semi-structured interviews, and unstructured interviews, I decided to use semi-structured interviews, which are the most favoured type of interview used in educational research (Basit 2003). There are several reasons for this choice. First, due to the fact that no frameworks or models for dealing with a Chinese audience viewing films and TV series produced in the English speaking countries have been found in the existing literature, the nature of Research Questions 3 and 4 is mainly exploratory. RQs 3 and 4 provide the main direction and issues to explore. However, the course of an interview needs to be flexible enough to allow supplementary questions, prompts and probes to be used during the interview in order to gain comprehensive, in-depth and rich data. Compared to other interview types, it is believed that the semi-structured interview meets the above requirements (Cohen et al 2007; Basit 2010), and hence is the appropriate research method for the project.

In terms of format of the interview questions, the *indirect approach* was adopted, because the less obvious the purposes of the questions are, the more likely frank and open responses will be produced (Tuckman 1972). Also, in addition to the main questions, prompts and probes were also prepared. Prompts provide opportunity to clarify topics or questions and probes allow the researcher to ask respondents to extend, elaborate, provide details for and clarify their answers. In this way the researcher is more likely to obtain the richness, comprehensiveness and depth of honest responses which are some of the hallmarks of successful interviews (Morrison 1993; Patton 1980).

According to the way in which an interview is administered, interviews are divided into two main types, namely, individual interviews and group interviews. *Individual interviews* comprise personal or face-to-face interviews and telephone interviews (Baker, 1999; Bryman 2004). Group interviews, sometimes described as focus groups or focused interviews (Baker, 1999; Bryman 2004), have been very popular because they are a less expensive yet effective way to get responses from a small group of people to a focused matter (Baker, 1999:224).

Hence, in addition to *individual interviews*, I decided to conduct *group interviews* as well in order to ensure the comprehensiveness, richness and trust-worthiness of the data. This is due to several characteristics of group interviews. First, a group interview can generate a wider range of responses than individual interviews. Second, a group interview can bring together people with "varied opinions, or as representative of different collectivises" (Cohen et al 2007:373). In addition, as Bodgan and Bklen (1992:100) indicated, group interviews are useful 'for gaining an insight to what might be pursued in subsequent individual interviews'. Also, some interviewees may not feel entirely comfortable being interviewed alone by a stranger.

In addition to the above beneficial features provided by group interviews, another reason for interviewing CCSs both individually and as groups is because, based on my personal experience as a student inside and outside of China, as well as observation as a college English teacher in China, CCSs watch films in different settings. For example, they sometimes watch program alone in their dormitory, at the cinema or at home. At other times, they may watch films together with friends or family members. By interviewing CCSs both individually and as a group, it was hoped to capture, as much as possible, authentic and comprehensive data which will give in-depth answers to the research questions.

However, group interviews are not without disadvantages. As Arksey and Knight (1999) rightly point out, some interviewees might be reticent in front of others. They also suggested that some people might be more dominant than others, who may withhold information and not speak out in front of other group members. As a result, a 'public-line' or 'group-think' (Watts and Ebbutt 1987) might be produced instead of more personal, honest response. In addition, as Watts and Ebbutt point out (1987), group interviews have little space allowing personal matters to emerge. These issues were kept in mind when conducting the group-interviews, and counter-actions were taken when these issues arose. For example, after asking the questions, I would let the more reticent interviewees express themselves first and then let the dominant ones speak. In addition, when the group provided uniform statements, efforts were made to ask each individual to give further explanation of their statement.

The design of the semi-structured interview I used will now be described. Each interview contained five stages (see Appendix 3 for details).

Stage A

Take personal information from respondents.

Stage B

Warm up interviewee by chatting casually, and meanwhile search for more information and further explanations on their answers to questions in Questionnaire section 3.

Stage C

A film card in A4 size was prepared in advance (Appendix 4). The card includes the names and posters of films and TV series, in total 36, showing on the front and back of the card. By showing the card to the interviewee, it was hoped to help the interviewee recall a memory of a film or TV series they have seen before. Also, by asking them about their memory of the program they've watched, what they think and how they felt about the program, it was hoped to identify any long-term effect (i.e. whether or not they had learned anything about Americans or British from the

program). Also, interviewees' answers were used to help decide on the clips which were viewed later.

Stage D

Twenty-three clips from seven films and one American TV series were chosen (see Appendix 5 for a description of each clip). There were three main criteria that were used to choose the clips. First, based on observation, research on IMDB, genre and anticipation, chosen clips should include the ones the interviewees might have seen before and the ones they might not have seen before. Second, the clips should cover as many different subjects and topics as possible. Third, based on my experience and knowledge as a Chinese citizen and college English teacher, I chose clips that contained issues which might stimulate rich responses from the Chinese students.

The average length of each clip was 2-3 minutes. Depending on the interviewees' answers to questions in Stages B and C, two or three clips would be shown to the interviewee. I always gave the interviewee a chance to choose what they wanted to watch. The clip was either from a film he or she had seen before, or from a program they had not seen before. After each clip I asked them a series of questions which aimed to discover how they made sense of the clip.

Stage E

The main purpose of this stage was to find out whether their teachers used films in their English classes. If their answer was no, I asked them questions to find out their opinions on using films in ELT. If the answer was yes, I asked them about their views on their teachers' methods. These views are a valuable resource for examining pedagogical implications of using films in ELT. In addition, by asking students to recommend any program they believe can help students learn more about the U.K. and U.S.A., it was hoped to get extra data to help answer Research Questions 3 and 4 (sense-making and effect).

In the fieldwork, both individual- and group-interviews were conducted following the above steps.

Having presented the rationale and design of the research methods (see table below for summary), the following section will look at the pilot study relating to the proposed research programme.

Research method	Research question(s)
Questionnaire	Research questions 1 & 2
Semi-structured interview	Research questions 3 & 4
Literature review (chapter 3)	Research question 5
Discussion (chapter 8)	Research question 6

4.3 The Pilot Study

“熟能生巧 (*Practice makes perfect*) *Pilot is fun yet rewarding.*” (My note on 7th August 2007)

It is highly advisable to carry out a pilot study before carrying out any major research project. A pilot study is an essential step in terms of the design of research programmes, as well as in enhancing the validity and reliability of the research methods (Basit 2010). As Basit (2010:71-72) also pointed out, a pilot study allows the researcher to:

1. Illustrate their ability to conduct and manage a study and lend credence to their claims
2. Verify the reliability of the research in general
3. Experience the mechanics of research, i.e.; gaining access to the sample, gathering data, and analysing data
4. Focus on a smaller sample to carry out research, using the same procedures that will be used in the main study, thereby gaining confidence as a researcher
5. Ascertain the validity and reliability of the data by concentrating on a few participants
6. Learn how to conduct research in an ethical manner
7. Test the research instruments, for example the interview schedule, the questionnaire and the observation checklist
8. Obtain feedback on the possible ways in which the research instruments can be improved
9. Modify the research instruments to eliminate any ambiguous, leading, insensitive, offensive or superfluous questions or statements
10. Revise the research instruments to include any significant questions that have been omitted
11. Determine the time required to complete the data collection and data analysis phases in the actual study
12. Highlight gaps and wastage in data collection
13. Predict research problems and establish the feasibility of the main study

I found Basit's list of advantages of conducting a pilot study particularly useful in terms of providing guidance for me with regard to *why* I needed to conduct a pilot study, *what* can be expected from the study, and *how* to carry out and make use of it.

I conducted the pilot study in Durham in August 2007. Due to the fact that in Chinese universities the summer vacation usually runs from mid-July till the end of August, at this time it would have been very difficult to access students on campus in China. Also, the first term of the Chinese academic year starts at the beginning of September, and so I only had one month to conduct the pilot study before the start of the fieldwork. In addition, in August many Chinese students who have just completed their undergraduate study in China arrive at Durham to undertake an English

language program to get them ready for their postgraduate study at Durham University. Being a Chinese research student and having been active in students' societies allowed me to have convenient access to these Chinese students. The fact that many of them had just completed four-year undergraduate study in China made it possible for them to provide an up-to-date picture of Chinese college students' life. Hence, it was considered appropriate to carry out pilot study at Durham University where, after the pilot study, I could also have face-to-face discussions with my supervisors before commencing the fieldwork.

4.3.1 Pilot Questionnaire

Piloting a questionnaire can increase the reliability, validity and practicability of the questionnaire (Morrison 1993; Wilson and McLean 2994:47). As Oppenheim (1992:48) emphasises, 'everything about the questionnaire needs to be piloted'. Basit (2010) also states that questionnaires need to be carefully formulated and piloted.

Fifty Chinese students, among whom there were 26 females and 24 males, participated in the pilot study. Due to the fact that we all lived in the same college, all the questionnaires were completed in my presence. I found this to be particularly useful and beneficial in terms of the practice of self-administration and the improvement of the questionnaire.

As mentioned before, the questionnaire was available in both Chinese and English. Participants were given the choice to choose whichever language they preferred. Interestingly, 39 out of 50 participants chose Chinese questionnaires, giving the reason that they were not confident enough to fill in English ones, because they were worried about giving the *wrong answer* due to misunderstanding of the questions. The 11 students who chose English questionnaire sought confirmation of their understanding of the questions several times with me during the process.

Due to the fact that some of the students who chose English questionnaire had difficulty with the language, in order to ensure the research subjects' accurate understanding of each question, it was decided to use only the Chinese questionnaire in the fieldwork.

In order to avoid any translation issues, six British graduate students filled in the English questionnaire in my presence. Their answers did not form part of the study, but part of the feedback which was concerned with the language of the questionnaire was taken into consideration.

Several amendments were made based on participants' feedback, including wordings in several questions in Part One and Part Four, the list of resources in Part Three, the list of films and TV series, as well as the Chinese translation on some of the films in Part Five. With regard to the

participants' feedback on Part Five, they not only helped finalize the list, but also played an important role in terms of the choice of films and clips for semi-structured interviews, which will be further explained in detail in the following section.

4.3.2 Pilot Semi-structured Interview

As with the questionnaire, all interview schedules were piloted carefully, which Basit (2010) suggests is an essential step in a research project.

Four individual interviews were carried out. Two male and two female students participated in the pilot interviews. No group-interviews were conducted due to the difficulty of finding a date and time which was convenient for everyone.

Having been able to conduct the full interview several times, I found the experience was extremely helpful in terms of formatting and delivering interview schedules, as well as in practising and improving my interview skills. Interview Stages A and B are quite straightforward, with questions which were not difficult to manage. Since the interviews provide the main data for the project, and in particular Stage C and Stage D are two core stages, the wordings of questions, sub-questions, probes and prompts was critical. To obtain maximum value from the pilot, I kept self-reflective journals after each interview. Also, since all the interviews were audio-recorded, I made sure to listen to the interview again before the next one. In doing so, I could not only improve my interview skills, but also identify directions and issues to address, and possible sub-questions and probes to try out at the following interview.

In terms of administering the interview, the pilot study showed that there was not always enough time for Stage E, because Stage C and D usually stimulated rich responses from interviewees, although interviewees responded to different clips differently. Since the questions in Stage E are not core questions, it was decided to leave enough time for Stages C and D in the fieldwork and to conduct Stage E if there was enough time left at the end.

In addition, I found that, due to the fact that I had spent a couple of years in the U.K. already at the time the pilot was conducted, some of the Chinese phrases and the forms of expression used by Chinese interviewees were difficult for me to understand.

4.3.3 Reflections on the Pilot Study

Referring back to Basit's list of advantages of pilot studies reproduced at the start of this section (Basit 2010), advantages 7 to 13 relate to improving the research instruments and administration of the main study. I have described in sections 4.3.1 and 4.3.2 the various improvements I was

able to make as a result of piloting both the questionnaire and the interviews, and these provide good examples of the advantages Basit describes.

Basit's advantages 1, 3, 4 and 6 relate to the development of the researcher. The whole pilot experience was a learning and self-improvement experience for me. Also, it was a major confidence boost in terms of thinking of myself as a capable researcher who could carry out research in an ethical way within schedule, as well as confirming to myself the great value of my research project and the appropriateness of the methodology (Basit's advantages 2 and 5). The pilot study also provided an opportunity for me to reflect and improve on my research skills, such as identifying and accessing the sample, and gathering and analysing data. Also, it allowed me to identify methodological issues, which meant that I was able to pay attention to subtle issues that might arise again in the main study. As a researcher I clearly gained all the advantages Basit describes.

Eventually, the main study collected rich, comprehensive and high quality data, due partly to the careful pilot study. The following sections will report the fieldwork that I carried out to collect both quantitative and qualitative data from September 2007 to October 2007.

4.4 Ethics Issues

Ethical considerations have been recognized as extremely important in educational research, and all researchers should ensure that their research is conducted in an ethical matter (Basit 2010). According to May (2001:59), "ethics is concerned with the attempt to formulate codes and principles of moral behaviour". Simons (1995:436) defines ethics as the "search for rules of conduct that enable us to operate defensibly in the political contexts in which we have to conduct educational research". Due to the fact that the research reported here deals with human being as subjects, every attempt must be made to adhere to relevant ethical principles. In this respect and according to Durham University Code of Practice (DUCP) (2004), all education research should be conducted within an ethic of respect for people, knowledge, values and quality of education research.

In addition to all above ethics issues, the ESRC (2005:1) states six key principles of ethical research:

- Research should be designed, reviewed and undertaken to ensure integrity and quality
- Research staff and subjects must be informed fully about the purpose, methods and intended possible uses of the research, what their participation in the research entails

and what risks, if any, are involved (though some variation is allowed in exceptional contexts)

- The confidentiality of information supplied by research subjects and the anonymity of respondents must be respected
- Research participants must participate in a voluntary way, free from any coercion
- Harm to research participants must be avoided
- The independence of research must be clear, and any conflicts of interest or partiality must be explicit

Specifically regarding questionnaires, Cohen et al (2007:317) emphasize that “respondents cannot be coerced into completing a questionnaire”. In terms of interviews, Kvale (1996: 111-120) summarises three main ethical issues, namely informed consent (written or orally), confidentiality and the consequences of the interviews. Basit (2010: 117) points out that:

The interview must be conducted with acute sensitivity and fitness. We must not be judgemental. We are interviewing them to discover their perceptions of the social world, not to impose our own views on them. Ultimately, we have to recognize that what the interviewees say is individual to them; it may be biased and subjective, but if it is their view of the social world, whether rational, blinkered, pompous or naïve, then it should be accepted.

In addition, Oppenheim (1992:64-65) advises researchers to be aware of the potential ethical problems in interviewing and the resultant biases that may be created as a result of these problems. He acknowledges some ethical issues connected with the way interviewees relate to interviewers. On the one hand:

- They resent instruction by a complete stranger
- They do not want to be too accurate or attentive in their responses
- They want to share in the control of the interview and ask questions of the interviewer
- They fear the potential use to which their responses might be put

And conversely:

- They may feel enormously flattered at being interviewed at all
- They may engage in elaborate displays of friendship and hospitality
- They may involve the interviewers in personal or family matters
- They may seek to strike up a lasting relationship

With regard to participants' privacy, it is worth emphasizing that, as Basit (2010) points out, ethical research respects participants' right to privacy not just during the research, but forever after.

All above ethical issues have been taken into serious consideration in the current research project. A detailed proposal specifying how the research would be carried out in an ethical manner was also submitted and approved by the departmental Ethics Committee.

Getting participants' informed consent is considered to be an essential part of conducting ethical research (Kavle 1996; Bryman 2004; Durham University 2004). Getting the informed consent of participants means that they agree to take part in the research after having been fully informed of their involvement expected by them, what will be done with the data, and whether there is any risk involved (Basit 2010). Cohen et al (2007:55) confirms that informed consent requires an explanation and description of several factors, including:

- The purpose, content and procedures of the research
- Any foreseeable risks and negative outcomes, discomfort or consequence and how they will be handled
- Benefits that might derive from the research
- Incentives to participate and rewards from participating
- Right to voluntary non-participation withdrawal and rejoining the project
- Rights and obligations to confidentiality and non-disclosure of the research, participants and outcomes
- Disclosure of any alternative procedures that may be advantageous
- Opportunities for participants to ask questions about any aspect of the research
- Signed contracts for participation

It is worth mentioning that I did not obtain written informed consent from my participants. I obtained oral informed consent from them instead. This is culturally specific to China. Based on author's experience and observation, although ethics is important everywhere, it is perhaps not being taken so seriously in China for the time being. The idea of trust is important, and it is particularly important in my case, an encounter between two strangers, the interviewer and the interviewee. If I asked them to sign a paper-based informed consent agreement, this would make the students feel as if I do not trust them and want to make sure to do something to protect myself. As a result, this will end up either with them withdrawing from the research or not being able to be completely relaxed and honest with their opinions during the interview. Hence, it was considered appropriate to get oral informed consent from them instead.

4.5. Fieldwork

Under this heading, there are two critical issues to be addressed, namely, *sampling* and *data collection*.

4.5.1 Sampling

The term sample refers to the segment of the population that is selected for research. It is a subset of the population (Bryman, 2004:543-544). Hence, sampling arises directly from defining the population on which the research will focus (Cohen et al 2007). "The quality of a piece of research stands or falls not only by the appropriateness of methodology and instrumentation but also by the suitability of the sampling strategy that has been adopted" (Cohen et al 2007:100; Morrison 1993).

Ideally, the target population of the current research is all the Chinese college students (CCSs) in China. However, in practice, this is impossible in terms of cost and time for me to carry out suitable research methods. Also, in China there is a huge gap between big, developed cities and relatively small, remote ones. As a result of differences of contexts, CCSs' experience may vary. Hence, it is impossible to find a sample which represents the whole population. An appropriate solution is to select a sample which represents a segment of the whole population (Basit 2010). There are several critical issues that need to be taken into consideration when sampling (Cohen et al 2007:100):

- The sample size
- Representativeness and parameters of the sample
- Access to the sample
- The sampling strategy to be used

During the process of determining the sample size, a number of things have been taken into account, including the purpose of the research being carried out, the nature of the population under scrutiny, the money and time available, the likely response rates, the number of the researchers conducting the research and the type of analysis being undertaken, as well as attrition rates and respondent mortality (Bryman, 2004; Cohen et al 2007). Gorard (2003:60) suggests that 'it is wise to overestimate rather than to underestimate the size of the sample required' (Gorard 2003:60) and to 'use larger rather than small samples, particularly in quantitative research' (Cohen et al 2007:118).

Consequently, taking into account all the foregoing factors, it was planned to include second-third- and fourth-year non-English-major undergraduate students from 15 universities in a big and modern city which is politically and economically developed in China (Beijing). First of all, this city

was chosen because, among all the cities in China, it has the most universities. Second, the college student population in the 15 universities is very diversified in the sense that they are from different regions and cities in China. Third, the targeted students major in different subjects, which are evenly distributed through the art, social science and science disciplines. The first-year students were not included because they had just completed their high-school study in July 2007 and registered in the university at the beginning of September. Hence, they would not have had sufficient experience of Chinese undergraduate students' life considering the length of time they would have spent in the university at the time the data collection was carried out. Also, undergraduate students who majored in English were left out, because their higher-level of English proficiency and more comprehensive knowledge on English speaking countries make them less representative.

The accessibility of the sample is another key issue that must be taken into consideration at the early stage of the research. It is critical to be aware not only of whether or not access is possible, but also of how access to the target group will be carried out (Cohen et al 2007:110).

Instead of approaching universities formally to get the permission from higher management personnel to allow me to conduct the research, I decided to use a more informal approach, contacting college English teachers directly. Due to the fact that I grew up and received education in Beijing, this was considered to be an effective and efficient way to secure research subjects, especially in view of time constraints.

There are two types of sample strategies, namely, probability (also known as random samples) and non-probability (also known as purposeful samples) sampling (Cohen et al 2007). Having taken factors such as sample size, accessibility, representativeness, cost and time available into account, it was decided to adopt the *convenience sampling approach*, which is usually defined as one type of non-probability sample strategy (Cohen and Holliday 1996; Cohen et al 2007). Convenience sampling means the researcher uses what is easily accessible to him/her (Basit 2010:52).

4.5.2 Data Collection

The data collection period lasted for a month from September 2007 to October 2007. There were two phases of data collection. I collected and analysed the quantitative data before conducting the semi-structured interviews, because, as mentioned before, some of the questionnaire findings would be helpful for the interviews. Hence, after collecting and analysing the questionnaire, the semi-structured interviews were carried out.

In terms of the questionnaire, 500 copies of the questionnaire were distributed, of which 425 valid responses were returned. Among the 425 respondents, there were 208 male and 217 female students. This is a good balance in terms of gender.

With regard to questionnaire administration, a self-administered approach was adopted. I used two types of self-administered approach, classified by Basit (2010) as *self-administered to be completed in the researcher's presence*, and *self-administered to be completed in the teacher's presence*. I self-administered the questionnaires in one university, where the students filled in the questionnaires in my presence. In terms of the other 14 universities, the teacher of each class administered questionnaires on my behalf.

There are two reasons for the above decision. First, having consulted targeted teachers from 15 universities, their feedback showed that the presence of the researcher was not necessarily required in all universities. Many teachers were confident that they would be able to administer the questionnaire. In addition, some of the teachers indicated that it was more convenient for them if the researcher was not present, because they planned on administering the questionnaire at the beginning of the class. I respected those teachers' feedback and provided them with a comprehensive and detailed briefing on the project, the questionnaire, and possible issues the students might raise with the teacher. This was done before the teachers were to administer the questionnaires, making sure they could answer student questions (a similar scenario is discussed by Basit, 2010).

My personal experience confirmed the advantages of a self-administered questionnaire to be completed in the researcher's presence, as, as Cohen et al (2007) points out, the researcher is able to provide any information requested by the respondents. However, based on the questionnaire return rate and validity, my research also showed that self-administered questionnaires to be completed in the teacher's presence is also a very effective approach, as long as the researcher provides a comprehensive briefing, and the teachers involved are well motivated and recognize the value of the research project.

I self-administered all the semi-structured interviews. Students participated in the interviews purely on a voluntary basis. In Part A of the questionnaire, students who were willing to be interviewed could leave me their contact information. I got in touch with all the students who indicated willingness to participate through an individual e-mail, which included explanation of the research purpose, a briefing on interview schedule and purposes, proposed dates, time slots and locations for them to be interviewed. This information was included in the e-mail itself, rather than in an attachment, because people might have been scared of possible viruses. Also, I offered

them the choice of being interviewed individually or in a group because some students may not have been comfortable to be interviewed by a stranger alone. These actions were carried out to ensure that the research subjects felt at ease and the research was conducted in an ethical way.

In the end, 14 individual and 3 group interviews were conducted. In terms of the group interviews, one group had four students (one male and three females), while the other two groups both had two female students. In total, 21 students were interviewed, among whom there were 7 male and 14 female students. Below is the list of the clips used for the interview. In total, 23 clips were chosen from 8 films and one TV series. Among those 8 films, two were set in the U.K. and 6 were set in the U.S.A. The TV series, *Friends*, is an American program, and the setting was mainly in the U.S.A.

Clip	Length (minutes)	Film/TV series
A father-son chat	2.5	AP
Before the ship sinks	5.5	T
Chandler's date	2.5	FS
Change the lock	2.5	C
Couple dinner	2	BJ
College day	1.5	FG
Dining saloon	4.5	T
Director	1.5	C
Lesbian wedding	2	FS
London bench day	1.5	L
Phoebe calls London	1.5	FS
Prepare for launch	2	BJ
Prom	1	AP
Rachel doing laundry	3	FS
Return home	3.5	BH
Shop for gun	2	C
Step off	3.5	SR
Stifler's party	4.5	AP
The noble right	2.5	BH
Two black men	2	C
Two policemen	6.5	
Virgin deal	3	AP
Women and children first	2.5	T

AP= American Pie (1999); BH= Brave Heart (1995) BJ= Bridget Jones's Diary (2001); C= Crash (2004); FG= Forrest Gump; FS= Friends T= Titanic (1997); LA= Love Actually (2003); SR = School of Rock (2003)

4.6 Validity and Reliability

"Validity is the touchstone of all types of educational research" (Cohen et al 2007:134). If a particular study is invalid, then it is worthless. Hence, validity is a key requirement for both quantitative and qualitative research (Cohen et al 2007:64). However, it is widely recognized that

it is impossible for research to be totally valid because threats to validity cannot be completely removed, though they can be minimized, in both quantitative and qualitative research (Basil 2010). Hence validity should be seen as a matter of degree rather than absolute perfection (Gronlund 1981). What can be done is to strive to minimize invalidity and maximize validity at all stages during research. Cohen et al (2007:144-146) suggest a number of ways to help minimize threats to validity throughout the various stages of a research project. The items on Cohen et al's list which are most relevant to my research experience in each of the stage of the study are as follows.

Research Design Stage

- Choosing an appropriate time scale (as discussed in 4.3)
- Ensuring that there are adequate resources for the required research to be carried out (through effective preparation)
- Selecting an appropriate methodology for answering the research questions (as discussed in 4.5.2)
- Selecting appropriate instruments for gathering the type of data required (quantitative and qualitative, as discussed in 4.5.2)
- Using an appropriate sample (as discussed in 4.5.1)
- Using appropriate instruments: ensuring that readability levels are appropriate; avoiding any ambiguity of instructions, terms and questions; using instruments that will catch the complexity of issues; avoiding leading questions; avoiding making the instruments too short or too long' avoiding too many or too few items for each issues (achieved through the pilot study)

Stage of Data Collection

- Minimizing reactivity effects (by offering the respondents the choice of group or individual interviews, and by my friendly approach)
- Trying to avoid dropout rates among respondents (by effective communication prior to conducting the research)
- Taking steps to avoid non-return of questionnaires (by effective communication with the teachers administering the questionnaires)
- Ensuring standardized procedures for administering interviews and gathering questionnaire data (also through effective communication with the teachers, and through conducting all the interviews myself)
- Building on the motivations and confidence of respondents (using my interpersonal skills)

Stage of Data Analysis

- Avoiding poor coding of the qualitative data (this took a lot of time and discussions with supervisors)
- Avoiding making inferences and generalizations beyond the capability of the data to support such statements
- Avoiding selective use of data
- Avoiding unfair telescoping of data (degrading the data)

To avoid the last three threats I was always very careful to be faithful to and honest with the data. This was helped by the fact I was analysing the data in the spirit of grounded theory.

“Reliability denotes that the research process can be repeated at another time on similar participants in a similar context with the same results. The data collection methods and the way the research is carried out have to remain uninfluenced by the difference in the sample and setting” (Basit 2010:69). Cohen et al (2007) suggest that “reliability is a necessary but insufficient condition for validity in research and validity may be a sufficient but not necessary condition for reliability” (p.133).

In terms of ensuring the reliability of qualitative data analysis, the ‘inter-rater reliability’ approach suggested by Denzin and Lincoln (1994) was applied. This means that, in order to strengthen the reliability of the interpretations of qualitative data, throughout the qualitative data analysis process I checked and discussed my interpretations of the data with my two supervisors.

Me being a researcher and an outsider to what was being researched, as all the subjects were undergraduate students whom I had never met before, made an important contribution to ensuring validity and reliability for both the quantitative and qualitative research. This researcher-being-an-outsider approach has been recognized by Bimrose and Bayne (1995).

In terms of interview validity, I made sure to be always aware of the potential issues raised by Cohen et al (2007:150) in order to minimize the amount of bias in the interviews as much as possible. They are:

- A tendency for the interviewer to see the respondent in his or her own image
- A tendency for the interviewer to seek answers that support preconceived notions
- Misperceptions on the part of the interviewer of what the respondent is saying
- Misunderstanding on the part of the respondent of what is being asked

Several examples will be given to illustrate how I avoided the above tendencies. For instance, there were no pre-conceived notions in this study. Also, several techniques were applied to avoid

any misperception of interviewees' statements, such as asking for clarification from interviewees and repeating back their statements in my own words. In addition, efforts were made throughout the interviews to make sure interviewees' answers were consistent with my questions. If an inconsistency was identified, I rephrased the question or broke the question into sub-questions. Also, prior, during and even after the interview, efforts were made to avoid myself being influenced by interviewee's appearance, personalities, views and experiences.

In addition, efforts were made to maintain good rapport with interviewees to ensure the 'honesty, depth, richness and scope of the data achieved', which is considered to be another effective approach to address qualitative research validity (Basit 2010:64). Several key elements proved to be helpful to building a good rapport. First, the initial greeting e-mail with briefing on the project, interview schedule, and flexibility in terms of date, time and location of the interview. Second, getting oral consent instead of written informed consent helped interviewees feel at ease. Third, as Oppenheim (1992) pointed out, having a high level of interpersonal skills makes rapport-building a lot easier. Another factor which came as a surprise to me was that my identity of being a twenty-something Chinese research student who is pursuing PhD degree in the U.K. presents a positive, hard-working and approachable-big-sister image to many interviewees, especially female interviewees, to whom I could relate to easily. As a result, my identity played a very positive role in building rapport, and maintaining smooth, pleasant and rich communication. Meanwhile, efforts were made to avoid too much rapport, because this might result in interviewees not taking the interview seriously (Cohen et al 2007).

Some researchers suggest that the interview transcripts must be taken back to the participants for validation. In this case, because of the nature of my research, I felt this was unnecessary and would not have made the research any more valid. As long as the researcher has gained the permission from the participants before the interview and has not in any way invented or distorted the data, the research is likely to be valid and ethical (Basit 2010). Gaining participants' validation by showing them the transcripts may risk losing important data. Not everyone likes to see their strong and/or critical views in print. Also, interviewees may say something in the interview and then contradict themselves later in the interview. From a research point of view, this might be an important finding, but the interviewees might want to remove the statements to avoid any embarrassment (Basit 2010). This is especially possible in the case of my research, where participants have been extremely open about their views and opinions. Due to the fact that films clips have been used during the interviews, rich and in-depth discussions have been stimulated. Hence, in order to avoid losing valuable data, I chose not to ask participants to read the printed transcripts.

Performance of a careful pilot study has been recognized as an effective way to enhance reliability (Cohen 2007). By doing a pilot study, I practised and improved the skills of administering questionnaires and interviews, and recognized the extended use of close questions, as well as the reliability in the coding of responses. In addition, several causes of bias in interviews proposed by Oppenheim (1992:151) have provided positive direction during my self-training process:

- Biased sampling
- Poor rapport between interview and interviewee
- Changes to question wording
- Poor prompting and biased probing
- Poor use management of support materials
- Alternations to the sequence of questions
- Inconsistent coding of responses
- Selective or interpreted recoding of data/transcripts
- Poor handling of difficult interviews

In addition, having been self-reflexive, I spent a great deal of effort preparing supplementary questions, probes, and prompts, as well as avoiding leading questions based on the lessons learned from each pilot interview.

In terms of the questionnaire, in addition to performing the pilot study (Morrison 1993), validity has also been addressed through a number ways which have been recognized in the literature as being effective, namely careful sampling, honesty, depth and richness of the data (Winter 2000), appropriate instrumentation and appropriate treatment of the data (Cohen et al 2007).

Cultural validity has been considered as another issue to address for the current research project. Morgan (2005) refers to *cultural validity* as the validity to be taken into consideration when a researcher conducts research in a culture which is different from his or her own (i.e. a British student carries out research in China). Although I am a Chinese research student with a Chinese nationality, by the time I conducted the fieldwork I had lived and studied in Durham University for almost two years. I had gradually, both socially and academically, adjusted to cultural context in Durham. In addition, the knowledge that I have learned and the teaching that I have received are western-school oriented. It was expected that, just as I experienced when I went back to China after one year of Master degree study in King's College London, I would experience reverse-cultural-shock when I went back to collect my data. This meant I needed to re-adjust to my own culture, both socially and academically. What happened in the pilot study, when I realised some of my Chinese vocabulary and ways of expressions were not up-to-date, also raised my awareness

on this issue. Hence, cultural validity was perceived as an essential element for my research. I made sure to gain a better understanding of the possible differences in attitudes towards research in both British and Chinese cultures, choose research instruments that were acceptable to the Chinese participants, checked the meanings of terms and phrases provided by participants which confused me, and was sure to be aware of my own cultural filters as a researcher.

4.7 Data Analysis Techniques

“Linda: I have learned the most from analysing data.

Mike (supervisor): I agree totally. When you buried yourself in the data, you were particularly honest handling the data and not ignoring complexities. Some other people, in order to get things done, just ignore it. But if you allow the complexities to emerge and face them, then you are doing it better, you are researching better.” (Transcript of supervision on 12th May 2009)

Both raw quantitative and qualitative data need to be analyzed to make sense of the meaning they are conveying (Basit 2003). Quantitative data offers a broad picture and precision, whereas qualitative data presents details and depth (Basit 2010; Basit 2003). Due to the fact that this study has collected both quantitative and qualitative data, various analysis techniques have been applied.

SPSS software has been used to analyze the quantitative data. The questionnaire was carefully formulated taking data analysis requirements into consideration. Most of the questions were closed questions. Although there were some open questions, the required answers were only words or phrases. Hence the quantitative data was straightforward to analyze.

Before the qualitative data could be analyzed, the interviews had to be transcribed (one individual- and one group-interview transcript samples are provided as Appendix 6 and Appendix 7). I transcribed the interviews in Chinese, the language used when conducting the interviews. As mentioned before, all interviews were audio-recorded with permission from the interviewees. Although Mishler (1986:365) argues that audio-recording ‘filters out important contextual factors, neglecting the visual and non-verbal aspects of the interview communication’ which ‘frequently gives more information than the verbal communication’ (Cohen et al 2007:36-7), it was not considered appropriate to use video-recording for the current research. There are several reasons for this decision. First, I self-administered all the interviews. During each interview, I not only audio-recorded the conversation, but also took notes when I noticed anything occurring worth noting (i.e. when the interviewee laughed, smiled or appeared to be confused when watching the clips). Each interviewee has a profile, which includes notes which were taken during the interview and reflexive notes taken after the interview. Second, video-recording is much more intrusive than audio recording. People can easily become uncomfortable when realising their every

movement is being recorded. Hence, I decided not to video-tape the interviews. As discussed before, in the Ethical issues section, as well as in the Validity and Reliability section, research needs to be carried out in an ethical way. Bias should be minimised. The use of video might risk interfering with interviewees too much, because they would be very aware of the camera's presence, and as a result, the data collected could have less openness or honesty. In addition, if using video makes respondents uncomfortable, it is not an ethical way to conduct research. Plus, it would not preserve the anonymity of the interviewees as easily. Most importantly, I listened to the audio-recording and took further notes right after each interview when my memory was still fresh. I took all the actions possible to ensure the comprehensiveness of the data.

4.7.1 Grounded Theory

"Linda: I'm not going to impose any theories on my data. I want to put what I have read before aside and just focus on my data to see what my data tells me.

Mike: Yes, let the data speak for itself." (Transcript for supervision on 23rd January 2008).

Grounded theory has been applied in the process of data analysis. In particular, qualitative data has been analysed in the spirit of grounded theory. That theory emerges from the data, instead of the data analysis being directed by existing theory, is a significant feature of grounded theory (Glaser and Strauss, 1967). As discussed before, the purpose of the qualitative data is to answer the core Research Questions 3 and 4 which are, in nature, exploratory. It would not be true to the findings to force any predetermined theory onto the data. It was considered most appropriate to let the data speak for itself, and to develop a theory that is grounded in data which is systematically gathered.

Hence, throughout the data analysis process, the four features of grounded theory summarized by Cohen et al (2007:491) have been the guiding principles:

- a) Theory is emergent rather than predefined and tested
- b) Theory emerges from the data rather than vice versa
- c) Theory generation is a consequence of, and partner to, systematic data collection and analysis
- d) Patterns and theories are implicit in data, waiting to be discovered

4.7.2 Bilingual Coding Techniques

Basit (2010:189) points out that 'coding is another significant element of the grounded theory approach, the purpose of which is to break down and deconstruct the data to make sense of them and then to reconstruct and synthesize the data to consider the links, similarities and differences'. Miles and Huberman (1994:56) define codes as 'tags or labels for assigning units of meaning to the descriptive or inferential information compiled during a study. Codes usually are attached to

chunks of varying size – words, phrases, sentences, or whole paragraphs, connected or unconnected to a specific setting. They can take the form of straightforward category label or a more complex one.

In the process of coding the qualitative data, I used both English and Chinese. I used whichever language that I felt could best describe what was in my mind and deliver my meaning. There are three reasons why this happened. First, the interviews were conducted in Chinese. Transcriptions are in Chinese. Automatically, the words or phrases used for coding would be Chinese. Second, although transcriptions are in Chinese, the majority of the literature is in English and this thesis is written in English. Third, due to the fact that I had spent considerable amount of time in the U.K. where the daily language for communication and study had been English, I sometimes thought in Chinese and sometimes in English. Before I came to the U.K., I always thought in Chinese. This is perhaps due to the improvement of my English proficiency.

During the data analysis process, Nvivo software was used to assist the organization of texts, codes, sub-categories and categories, instead of the traditional cut and paste method. Nvivo was only used to help organize the data. The software was not used in the analysis.

Although the qualitative data focuses on a smaller number of people than the quantitative data, the data collected was very detailed and rich. Cohen et al (2007:461) state that there is no single or correct way to analyse qualitative data. In addition to the four principles of grounded theory presented in previous section, the principles of *fitness for purpose* and *always keeping research questions in mind* have been guiding me through the data analysis.

Due to the fact that no existing theory was imposed on the data, which is extremely rich and complex, the qualitative data analysis process was very time-consuming. I tried two different approaches. At the beginning, I tried to treat the data as a whole and looked for patterns and categories. This turned out to be inappropriate approach, because the individuality of each participant was largely sacrificed, which ended up losing valuable findings. Hence, it was decided to combine two different approaches, treating each interview data separately, but meanwhile looking at data as a whole to see broad categories.

Several coding techniques have been applied during the analysis process, namely, open, axial, selective and constant comparison, all of which are recognized as key coding methods in grounded theory (Basit 2010). Constant comparison, which was referred to as the core method of analysis by Glaser and Strauss (1967), has been extremely helpful in my case. Strauss and Corbin (1990) state that the function of the constant comparison method is that it helps the research break through assumptions and uncover new dimensions. By using constant comparison, not only

did categories become clear and emerge from the data, but I could also draw on my personal experience and professional knowledge, as well as relevant literature on the subject. In particular, by drawing on personal experience, I came to understand myself better and better, and, meanwhile, also understood data better and better. As Walford (2001:98) points out, “all research is researching yourself”.

During the data-analysis process, I adopted Mason’s (2002) three types of data-reading-approaches, namely literal reading, interpretive reading and reflexive reading. These techniques have been very helpful, especially when I struggled with coming up with categories.

I have also come to realise that there is not always one single meaning of a text. As Cohen et al (2007) point out, texts carry many layers of meaning, requiring researchers to exert a great amount of effort in striving to catch them. Interpretation usually happens simultaneously with data analysis, especially during the coding process. At the initial stage of data analysis, I ended up having more than 300 codes. In the process of categorising and grouping the codes, it became apparent that it was not a straightforward process. Some of the texts can have more than one code. Some of the codes seem to belong to more than one category. There is not always a clear-cut division between categories. Many of them are inter-connected. The final lists of categories under two themes, *make sense* (RQ3) and *effect* (RQ4) are presented below. (A list of codes from which the categories were developed is provided in Appendix 8.)

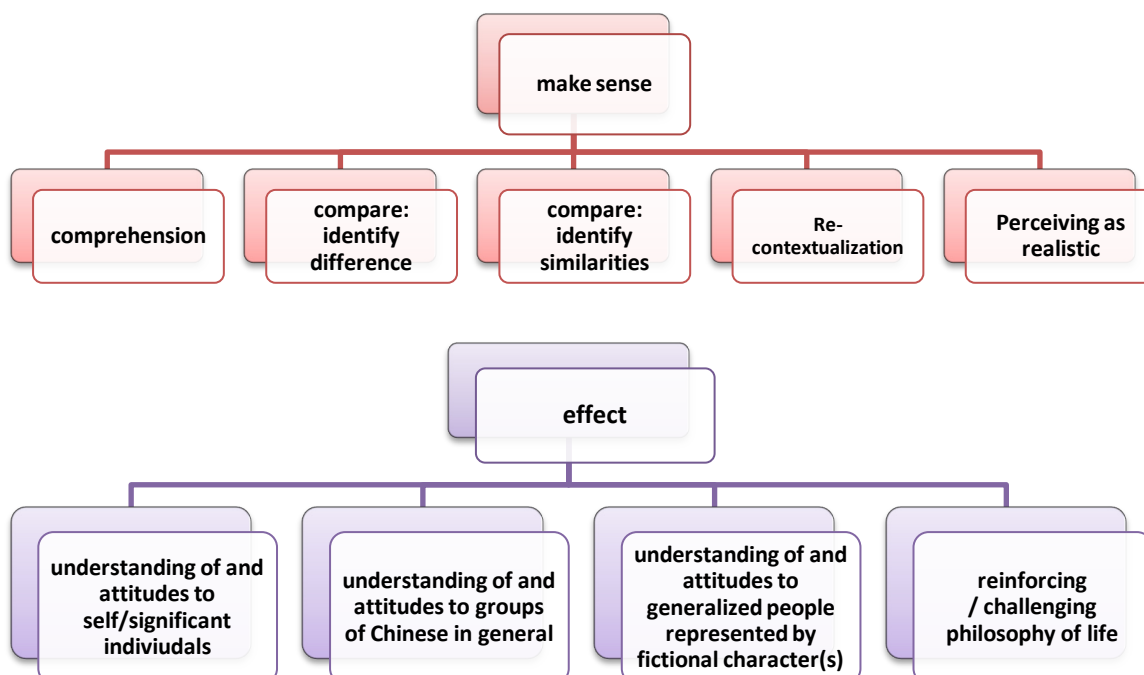

The role that I have been playing during the journey of data analysis has gradually drawn my attention. The research subjects were Chinese students who were still studying in China. I am a Chinese researcher who has been studying and living in the U.K. for several years. Being older than the research subjects, having received higher education, and having more life experience both in China and the U.K., has made me able to have more insight into the clips than my subjects. This allowed me to understand and evaluate the CCSs' interpretation of the clips and identify any misunderstandings which are culturally specific. However, sometimes it occurred to me that, although I have been looking at the codes that emerged from the data as the *other*, and trying to distance myself and look at the data as an outsider, the Chinese culture deeply rooted within me caused me to experience a reaction towards a couple of the clips similar to my research subjects. This sometimes made me feel like I was switching places.

4.7.3 Bilingual Data Presentation

Berremán (2004) suggested that it is not possible to literally translate words between cultures, because languages and people are shaped by their cultures. My data analysis experiences agree with Berremán's view. As mentioned previously, all interviews were conducted in Chinese, and hence the Chinese transcripts. In addition to the bilingual-coding during the data analysis process, I presented selected text extracts both in Chinese and English for my two supervisors in each supervision session. Those sessions turned out to be very useful, because we identified and tackled several translation difficulties thanks to the input from my bi-lingual and bi-cultural supervisor-team. In addition, in the process of writing up data analysis, I gradually realised an issue in regard to translation. Translating from one language to another is like cooking a foreign dish. Sometimes, although all the right ingredients are used, the taste might not turn out to be the same. Hence, I agree with Gonzalez and Lincoln (2006) in terms of the importance of presenting the data in its natural language, and the importance of making data accessible for readers of the language.

Consequently, making the results accessible in the multiple languages, will give readers the option of the original language of the data along with the "presentation" language (p.34).

As the current study is mainly concerned with using films and TV series produced in the U.K. and the U.S.A. in ELT in the Chinese context, it is safe to assume that the readers will be able to speak either English or Chinese or both. Hence, it was decided that the text extracts be presented both in Chinese and English in the data analysis chapters.

4.8 Valuable Extra

Throughout my research journey, many ideas, reflections, questions, and insights emerged when I was reading, walking, working in the library or having supervision sessions with supervisors. I managed to keep notes whenever I could by writing on my notebook, in my laptop, in my mobile phone etc. Also, I kept audio-recording for all sessions that I had with my supervisors. Afterwards, I always transcribed them and kept a copy together with a supervision record with main issues listed. All of these notes and memos have been extremely helpful for data analysis. Robson (1993:387) argues that memos are not data in themselves, but help the process of data analysis. However, Cohen (2007:467) holds a slightly different idea that “if reflexivity is part of the data analysis process then memos may become legitimate secondary data in the process or journey of data analysis.”

No matter whether memos are categorised as secondary data or merely notes, the role they play and value they add onto a research project cannot be underestimated. As has been widely recognized, a researcher brings their own perceptions, interests, bias, preferences, biography, background and agenda into the data (Cohen 2007; Walford 2001), and therefore well-kept memos and notes, which function as record of reflexive journey of researcher, should be taken into serious consideration.

Having been supervised by a bilingual- and bicultural-supervisory team has been truly valuable throughout every stage of my research project. I have two supervisors. One of them is British and the other one is British-Chinese who is bilingual. Each supervision session was an intercultural encounter among three researchers with different cultural backgrounds and identities. The richness of and inspiration from such encounters are not achievable from mono-lingual and mono-cultural encounters. I see this as an extra advantage. For example, during data analysis, my supervisors were able to view and interpret data from different cultural perspectives, which was truly helpful. In addition, their world views and beliefs also influenced the data analysis.

Although the data was extremely rich, messy and appeared to make no sense to me at the initial stage, patience, faith, being-honest-to-data, and creativity have proved to be the keys to unlock the door to the advancement of knowledge.

*“Linda: You are right that I am honest with my data. Along the way, I am becoming critical. I understand myself better. I realised that, I learned a lot about philosophy of life, differences among people from my data, not from textbooks.
Mike: (smiles).”* (Transcript of Supervision on 12th May 2009)

Chapter Five: Data Analysis – Research Questions 1 & 2

The previous chapter has discussed the research questions, research method, data collection and data analysis approach. The current chapter reports the findings relating to Research Questions 1 and 2.

- **RQ1: From which resource do Chinese college students (CCSs) think they learn the most about the people and cultures of English speaking countries, in particular the U.K. and the U.S.A.?**
- **RQ2: What type(s) of media do CCSs prefer to use in order to learn about people and cultures of the U.K. and the U.S.A.?**

The purpose of RQ1 is to confirm the author's hypothesis that films (including TV series) produced in the U.K. and the U.S.A. are one of the major resources available in the Chinese context for CCSs to learn about the above two countries. The hypothesis was based on author's personal experience and observation as a college student and college English teacher in China, where CCSs seem to have very little direct exposure to the U.K. and the U.S.A. RQ2 aims to discover, among all the resources available, whether films (including TV series) produced in the U.K. and the U.S.A. are one of the resources CCSs would like to use when they want to learn more about these two countries. Although RQ1 and RQ2 are not the core questions of the current study, it is believed that the findings will provide useful information for English language teachers in China. The findings also confirm the importance of the core questions of the study.

Data to answer the first two research questions was mainly obtained from the questionnaire survey, and so this chapter will concentrate on the questionnaire findings. However, some explanation of and reinforcement to the questionnaire findings were obtained from the interview data, and so those findings, together with some interview extracts, will be presented as well. Most of the interview data will be discussed in the following two chapters.

With regard to the questionnaire participants, among 425 questionnaire respondents there are 208 male and 217 female CCSs. In terms of gender, this is a good balance. The majority participants were in the 2nd year of their undergraduate study (80%), 11% were in the 3rd year and 9% were in the 4th year (final year). The majority (76%) of students were aged between 16 and 20, 24% were aged between 21 and 25. There was only one student who was aged between 26 and 30. In terms of interviews, 14 individual and 3 group interviews were carried out. In total, 21 students were interviewed, among whom there were 7 male and 14 female students.

The empirical findings will now be presented in the order of research questions.

5.1 Research Question 1

The author’s personal experience and observation led to a hypothesis that most of the CCSs might not know a lot about the English speaking countries, in particular the U.S.A. and the U.K., due to limited direct contact with the target cultures. Hence, in the questionnaire, students were asked to indicate, by selecting the relevant number from 5 (quite a lot), 4 (a lot), 3 (some), 2 (little) and 1 (very little), how much they believed they knew about the main English speaking countries, U.S.A., U.K., Australia, Canada, South Africa and New Zealand. I had particular interest in finding out how much CCSs believe they know about the U.K. and the U.S.A.

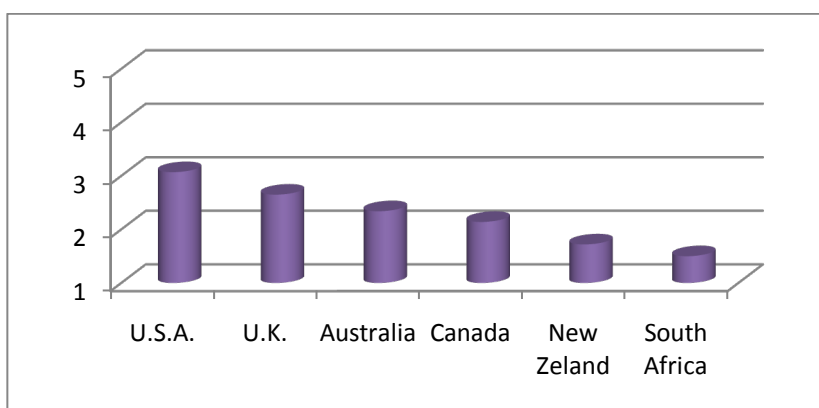

Fig. 5.1 Average response to knowledge about English-speaking countries (5=quite a lot; 1=very little)

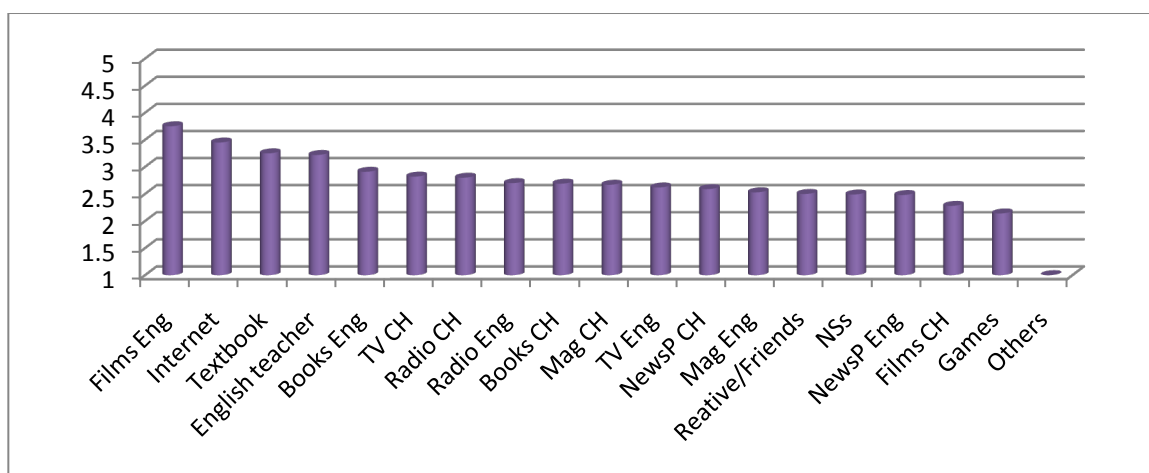

Fig. 5.2 Average response to knowledge gained from learning resources (5=quite a lot; 1=very little)

Figure 5.1 shows the weighted average response for each of the listed English speaking countries. Although the amount of perceived knowledge is generally low, the U.S.A. is the country students

believed they knew most about, with the average response being ‘some’ knowledge. As Figure 5.1 shows, students believed their knowledge of the U.K. was somewhere between ‘some’ and ‘little’.

With regard to how much those students believed they learned about the U.K. and the U.S.A. from a set of listed resources, Figure 5.2 shows the questionnaire findings based on students’ selections from one of the five numbers, 5 (quite a lot), 4 (a lot), 3 (some), 2 (little), and 1 (very little).

The top four resources from which students believed they learned more than just ‘some’ knowledge about the U.K. and the U.S.A. were films produced in the U.K. and the U.S.A. (Films Eng), internet, English textbook and English language teacher. Among the top four resources, films were perceived as providing almost ‘a lot’ of knowledge for the students (3.75), followed by internet (3.45). Textbook and teacher were almost equal (3.25, 3.22). It is worth noting that native English speakers (ranked the 4th from the bottom) were not ranked as a major learning resource. This probably indicates that these college students had very limited direct contact with people from English speaking countries, and that their exposure to the peoples and cultures of the U.K. and the U.S.A. mainly relied on indirect sources. Comparing TV and radio programs produced in the U.K. and the U.S.A. with the media programs produced in China, students believe that they have learned more from the Chinese ones than from the English ones. They also believe they learnt more from Chinese newspapers than from English newspapers, but learnt more from English books than Chinese books.

With regard to RQ1, interview findings reinforced the questionnaire findings that films produced in the U.K. and the U.S.A. have been the main resource. The word ‘films’ is usually interpreted as both films and TV series.

- **1st main resource: Films and TV series produced in the U.S.A. and the U.K.**

Based on interview findings, among the films and TV series those students watched, the American ones are much more popular than the U.K. ones. Three possible reasons were indicated.

First, American films and TV series were more popular and easily accessible on the internet. The data suggests several common ways for the interviewees to access films and TV series, including the internet (downloading pirated films), the university website (full-length feature films and TV series), the film club at the university, and buying pirated DVDs from street vendors and from the supermarket. Several popular websites mentioned by the interviewees that provide pirated film downloading and on-line watching services are VeryCD, Emule and Tudou¹² (土豆网). One thing

¹² 土豆网 (Tudou): is one of the largest video websites in the People’s Republic of China where users can upload, view

worth mentioning is that, when the author was in the same city where the empirical data was collected in the summer 2010 three years after the survey was performed, she noticed that the supermarkets do not sell pirated DVDs any more. However, pirated DVDs can still be bought from street vendors.

Second, peer influence appears to have strong impact on some students' choice of films. With regard to American films and TV series, it seems that contemporary TV series, Hollywood films and blockbusters are particularly popular. Third, teachers' recommendation appeared to affect students' choice of viewing as well. For example:

(Q.5.1.1)

Interviewer: 你们都看什么剧? 美剧还是英剧?

CM: 不看英剧。

LM: 美剧, 一般都看美剧。

Interviewer: 为什么看美剧?

CM: 因为比较 popular .

LM: 对, 英剧我们都获得不了资源, 我们都不知道最近什么英剧比较流行, 但是美剧就很快就传过来了。

CM: 对对。《越狱》啊什么的, Hero 啦, 《实习生格雷》啊, 《绝望的主妇》啦什么的, 很多啦。而且同学他们都在叫我看。谁看了一个都会很激动跟我说, 诶呀什么什么很好看。(看着 LM)比如说她一直在宿舍里喊, 《越狱》很好看。

LM: (笑) 然后你就被拉下水了, 哈哈。然后最近我们就在宿舍里。《实习生格雷》很好看。

English translation:

Interviewer: What TV series do you watch? American ones or British ones?

CM: (I) don't watch British TV series.

LM: American TV series. Usually (we) all watch American ones.

Interviewer: Why American TV series?

CM: Because they are more popular.

LM: Yah, we don't have resources to get the British TV series. We don't know what's popular recently. But American TV series are quickly available online.

CM: Yah, yah. Like, *Prison Break*, *Hero*, *Grey's Anatomy*, *Desperate Housewives*, etc, a lot. Plus, the course mates all asked me to watch it. Everyone who watched it told me with excitement how good the show was. For example, (looking at LM) she kept telling me, in the dorm, how fantastic the *Grey's Anatomy* was.

LM: (laugh) haha, welcome to the club. We've been watching *Grey's Anatomy* recently in our dorm. It's great to watch.

- **2nd Main resource: Internet**

Questionnaire findings indicated another main resource is internet. In terms of the internet, when some interviewees were asked to give more details of what they do on internet, most of the activities mentioned were related to entertainment. Several popular activities were mentioned by the students, such as downloading films, on-line shopping, chatting and playing games. Students did mention that they occasionally get some on-line articles when they had papers due.

- **3rd main resource: English textbook**

As discussed, English textbook is another main resource for those students. However, students seemed to have low expectations of it. For example:

(Q.5.1.2)

PWB: 教科书属于那种条条框框式的。就是说它专门给你讲，比如说英国的吃饭的 table manners 和中国的有什么不一样，就一条一条列出来，[...]反正教科书上是一条一条的，干的死的。就是那些你就了解到了。

English translation:

PWB: Textbooks are like, sticking within the box. I mean, it specifically tells you, for example, the differences between British and Chinese table manners, which are listed one by one. [...] what's in the textbook is like a list, dry and not flexible. That's all you learn from it.

- **4th main resource: English language teachers**

As shown by the questionnaire results, English teachers ranked as the fourth most influential learning resource. However, there is inconsistency in terms of to what extent students were satisfied with their language teachers' teaching when it comes to 'teaching target culture'. According to the interviewees, language teachers mainly use two approaches. One is the approach of introducing cultural background which is relevant to the curriculum and textbook content. The other one is to share personal experience of studying or travelling in the English speaking countries. Two exemplary text extracts are presented below.

(Q.5.1.3)

HWY: 我觉得她/他会扩充一点。就是她/他在讲她/他的课文，和她/他课文有关的，讲一点当地的文化背景。但不是很多，只有零星的一点。

English translation:

HWY: I think s/he could expand a little. S/he could introduce a little bit of cultural background which is relevant to the content in the textbook. But not a lot, only a little bit.

(Q.5.1.4)

LM: 我觉得咱们的老师去过很多国家，上课的时候讲很多她/他的经历。我觉得大学老师还好一点，高中的英语老师就直接教课本就没有什么了解。

CM: 高考。

LM: 对对。上大学以后我觉得我们这个老师，有在外国求学的经历，上课的时候会时不时给我说好多。

English translation:

LM: I think our teacher has been to many countries, and s/he talks a lot about her/his personal experiences during lessons. I think English language teachers in the university are better, teachers in high school just taught us the content directly from the textbook without any understanding.

CM: (for) the university entrance examination.

LM: Indeed. After entering the university, we feel that our teacher has experience of studying abroad, and s/he talks quite a lot about it (the experience) now and then during the classes.

• **Other resources**

Some other types of resources were mentioned by the interviewees as well, such as the radio programs produced in the U.K. and the U.S.A. (BBC and VOA). There were three main ways to access to them. One was downloading from the internet. Another one was to buy pirated CDs. They also reported that the English language teachers sometimes used these programs in the listening classes. It is worth mentioning that the main purpose of using BBC and VOA by interviewees was to improve their listening skills. However, they also believed that, while they are practising listening skills, they can also learn something about those two countries. Two types of Chinese radio programs were mentioned too. They are Easy FM¹³ and CRI¹⁴. These two programs seem to be very popular among the students. The main reason for listening to these radio programs was to improve listening skills.

5.2 Research Question 2

As explained previously, Research Question 2 aims to find out what type of media Chinese college students prefer to use when they want to learn more about the U.K. and the U.S.A., as opposed to ones they thought they learn from (RQ1). Students were asked to choose their first and second preferences from the resources listed in the questionnaire. The findings are indicated by Figure 5.3.

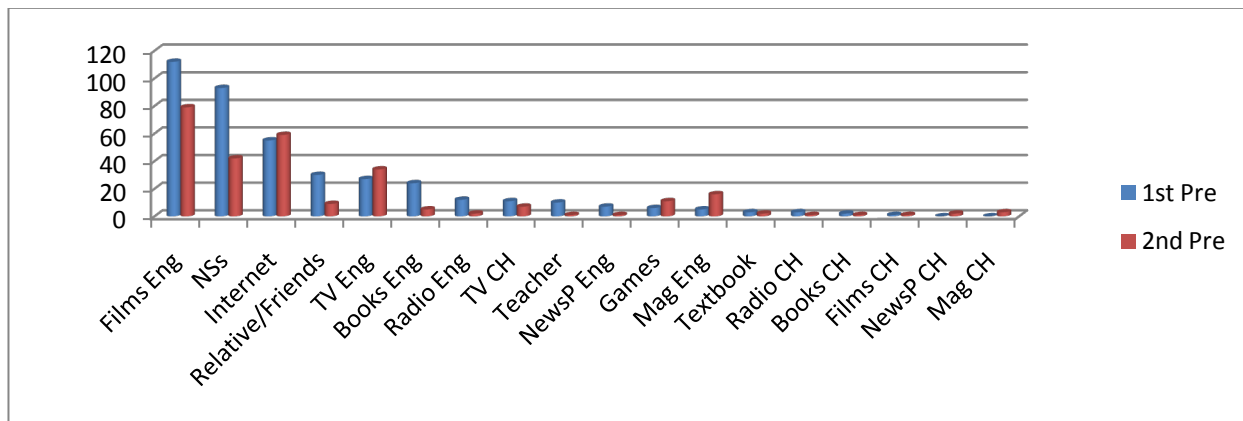

Fig. 5.3 Preferences for resources for learning about the U.K. and U.S.A.

As illustrated, films produced in the U.K. and the U.S.A. are at the top for both the first and the second choice. Hence, it is reasonable to conclude that it is the most popular type of media program for those Chinese college students to use when they want to learn more about the U.K.

¹³ Easy FM: is a radio station in Beijing, China on 91.5 FM. It is a member of the China Radio International group of radio stations. The programs are in English, while the commercials are in Mandarin (the official language of the country). Internet streaming is available. There are hosts from China and English speaking countries.

¹⁴ CRI: is a radio station on 91.9 FM, which is a part of China Radio International. It broadcasts in English and Mandarin. It was launched in February 27 2006. There are hosts from China and English speaking countries.

and the U.S.A. The second popular type of media is internet, followed by TV programs, books and radio programs produced in the U.K. and the U.S.A. It is worth noticing that although English native speakers appeared not to be a resource from which these students have gained much knowledge, the students still have high interest in face-to-face interaction with British and Americans. On the other hand the English teacher, one of the main resources of current knowledge, was only ranked 9th in terms of preference. Similarly, English textbook was ranked the 6th from the bottom in terms of preference, when it was ranked as one of the main resources in response to RQ1. This indicates that students might not have high expectation of and may lack interest in the English language teacher's teaching and the English textbook.

- **Why do most students prefer films and TV series?**

Why do these students prefer to use films more than all other resources? Some explanations are provided by the interview data. For example,

(Q.5.2.1)

GH: 电影很直接, 然后也比较真实, 毕竟是外国人直接拍的, 比较真实。再一个也很快, 看报纸的话, 很多单词也不认识所以很困难。

Interviewer: 你说的很快是什么意思?

GH: 很快就是, 它有一些文化的很深层的东西, 可以通过他的动作和语言表达出来。但是看报纸的话, 也不是说不容易, 但是比较困难。

Interviewer: 为什么困难?

GH: 因为读英文报纸, 毕竟不是那个专业的学生, 所以要费一些时间。而且看那些电影的话, 因为它毕竟是一个完整的剧情, 而且是自己喜欢的题材, 所以比较有兴趣, 所以能够看下去。然后在那个过程中接受他们的东西

English translation:

GH: films are direct, and also relatively more realistic, after all, are made by foreigners directly, and are quite realistic. Also, films are fast. Reading (English) newspaper is very difficult because there are many words that (I) don't understand.

Interviewer: What do you mean by 'fast'?

GH: Very 'fast' means, there's some in-depth cultural things that can be expressed by his/her (actor) movements and language. But reading a newspaper, I don't say it's not easy, but it's relatively more difficult.

Interviewer: Why difficult?

GH: Because reading English newspaper, after all, (I am) not majoring in English, so (I have) to spend some more time. However, when watching films, because, after all, there is a complete story line, plus the subjects are the ones that I like, so I have more interest and therefore can keep watching. Then, during the viewing process, (I) learn things about them.

(Q.5.2.2)

PWB: 看着不累。看报纸, 看一会就累了, 其他的, 看觉得挺无聊的。电影我觉得是一个比较好的方式吧。[...] 但是电影是比较, 比较, 综合的, 比较一次性的, 就能提供这么多。

English translation:

PWB: It's not tiring to watch. I get tired after reading a newspaper for only a little while. Others, boring. I think films are good. [...] However, films are relatively more comprehensive, and all-together at once provide this much (of information).

The comments above indicate that the characteristics of film (i.e. audio-visual, telling the whole story) make films stand out among other resources. It seems that students' English language difficulty is one of the main reasons which make films stand out. The combination of audio and visual makes it easier for the students to understand and follow the meaning than with other types of resources, such as English newspapers. Also, several phrases were frequently used by different interviewees to explain why they prefer films, such as 直接 (direct), 快 (quick), 综合 (comprehensive), 一次性 (altogether at once). This further indicates that the fact that a film can stimulate the visual, audio and cognitive senses of the students at the same time makes the content easier to understand and follow, so the students experience both less fatigue and more sense of achievement. Second, the fact that each film tells a whole story, and that the subject matter is likely to interest the students, makes it easier and more interesting to watch.

It is worth mentioning is that GH seems to perceive films as reflecting reality, as shown above (Q.5.2.1). The main reason from his point of view is that the films were made by native English speakers. GH is not the only one who holds this view.

(Q.5.2.3)

GMX: 电影，就是能够反映一点美国那种现实吧。现在美国的大片大部分都是为了满足，他们平时太紧张了，然后就满足那些视觉和听觉感受的那种，就 Hollywood 的电影好多就是那样的，就是反映一些现实的电影好象也不是很多

English translation:

GMX: Films, kind of can reflect a bit of the reality of the U.S.A. Nowadays, the majority of American blockbusters are made for satisfying (people), they (people) are too stressed, to satisfy those visual and auditory experience, many Hollywood films are like that. Few of those films can reflect reality.

(Q.5.2.4)

CJY: 觉得还是电影吧。我还是希望通过电影来了解一些的。就是有些电影我觉得，它们，只要我觉得那些导演，只要它有深度，然后这种他的电影应该还是能够表现一些东西的。只要不是我觉得那什么科幻啊什么的，然后纯粹就是，比如说就展现他们的高科技什么的，不要是这种。或者是一些很细的那些东西，我觉得还是可能展现他们那种生活细节的。人物风情的，然后通过那个还是可以看到很多别的国家。比如说这个 *Forrest Gump*，他不是一直在跑嘛，然后这些途中，然后，还是可以看到美国优美的风景啊。

English translation:

CJY: I think it's films. I do wish to learn more from the films. I think, some films, they, as long as those directors, as long as it (film) is deep, films of this kind can reflect stuff. I think, as long as it (film) is not sci-fi, and not purely, for example, to show-off high technology etc, not films like this kind. Or (the type of films portray) very detailed things, I think, can reflect details of their life. Films about people and scenery, (I) can see a lot of other countries through them. For example, *Forrest Gump*, he keeps running, along his journey, then, I can see a lot of beautiful scenery in the U.S.A.

The similarity between GMX and CJY is that both of them perceived films as, to some extent, reflecting the reality of the country of origin. Comparing GMX and CJY with GH (Q.5.2.1), it seems that GH's perception appears to be more extreme and generalized. They have different criteria for judging the extent of reality. These criteria fall into three categories: the genre of the film (i.e. sci-fi, romance), the type of film (i.e. Hollywood, blockbuster) and the maker of the film (i.e. made by native English speakers).

The comments quoted above indicate two main reasons why films produced in the U.K. and the U.S.A. are the most popular among the research participants. The first is to do with students' English difficulties. The second is to do with the characteristics of films, such as audio-visual, full story-line. The third is related to students' perceptions as to what extent films reflect reality, which might be relevant to their expectations during film-viewing.

- **Why do students prefer native English speakers?**

The second most popular resource indicated by the questionnaire findings was Native English speakers. However, interview data show that, although students prefer this resource, there was limited contact in their context.

As the questionnaire findings also indicate, Internet ranked the third most popular resource among the participants. The characteristics of internet (informative and convenient) appear to be the main reason that makes it popular. However, according to the interview data, students tend to visit Chinese websites for entertainment purposes, such as playing on-line games, on-line shopping, reading Chinese novels, gossiping about stars (both Chinese and foreign) and on-line chatting.

- **Why do students NOT prefer English language teachers and English textbooks?**

As shown by the questionnaire finding, the English language teacher was only ranked 11th and English textbooks ranked 13th by the participants. Interview findings indicate that some of the students were not entirely satisfied with their English language teacher's approach (content and techniques) and the content of the textbook. For example,

(Q.5.2.5)

GH: 课本那个肯定是，它为了学校才编的教材，肯定是比较生硬的。老师，因为上课比较少，二年纪，[...]他/她上课主要还是讲课本，讲他/她自己的课件。所以介绍的很少。

English translation:

GH: Textbooks are definitely (a source of cultural learning), (but) because they are specially edited for the universities, they are certainly quite crude. Our teacher, because there are fewer English lessons in the second year, [...]s/he mainly sticks to

the textbook content, lectures her/his own course materials. Hence, introduces very little on culture.

(Q.5.2.6)

PWB: 教科书属于那种条条框框式的。就是说它专门给你讲，比如说英国的吃饭的 table manners 和中国的有什么不一样，就一条一条列出来，[...]反正教科书上是一条一条的，干的死的。就是那些你就了解到了。

English translation:

PWB: Textbooks are like, sticking within the box. I mean, it specifically tells you, for example, the differences between British and Chinese table manners, which are listed one by one.

[...] what's in the textbook is like a list, dry and not flexible. That's all you learn from it.

(Q.5.2.7)

HWY: 除了上英语课，老师会推荐一些英语网站。其实是很表面的东西。而且我们也很想去了解那个，当地的真正的文化是什么。

English translation

HWY: In addition to English lessons, (English language) teachers would recommend some English websites. Actually those are superficial stuff. Plus, we also want to understand the real local culture and so on.

The current chapter has provided the answers for Research Question 1 and 2. As discussed, films and TV series in the U.K. and the U.S.A. have been the main resources available for CCSs to learn about these two countries. Although English textbooks and English language teachers are two other main resources, students do not have high expectation of them. Among the films and TV series students have access to, most of them are produced in the U.S.A. When students want to learn more about the U.K. and the U.S.A., the resource they would prefer to use is films and TV series produced in the U.K. and the U.S.A. Although students would love to have direct contact with native English speakers from these two countries, access in the Chinese context is too limited. Sadly, English teachers and textbook were ranked very low by the participants.

The answers to the first two research questions demonstrate the importance of the main part of this study. Given that films and TV series are the primary method by which CCSs learn about the target cultures of English language teaching, and given that students would like to make more use of these resources, teachers must understand how students make sense and learn from them. Hence, this leads to the core research question for current study, which is how students actually make sense of films and TV series produced in the U.K. and the U.S.A. Also important for teachers to know is whether viewing films and TV series produced in the U.K. and the U.S.A. has any effect on students' knowledge and attitudes to the people and culture of these two countries. The following chapters will unveil the findings step by step.

Chapter Six: Data Analysis – Research Question 3

The current chapter presents the empirical findings gathered from semi-structured interview data which answer the following research question.

- **RQ3: How do Chinese college students (CCSs) make sense of films and TV series produced in other cultures, specifically films and TV series produced in the U.K. or U.S.A? (core question)**

As discussed previously, 14 individual and 3 group interviews were carried out. In total 21 students were interviewed, among whom there were 7 male and 14 female students. In each interview, participant(s) viewed 3 to 4 clips chosen from films and TV series produced in either the U.K. or the U.S.A.

Research Question 3 aims to investigate how Chinese college students make sense of films and TV series produced in the U.K. and U.S.A. As the findings gathered from the interview data will show, for these Chinese college students making sense of films and TV series produced in the U.S.A. and the U.K. is a very complex process, rather than the linear process many language instructors assume.

‘Comprehending the plot’ is the first of the five main categories of sense-making activities which emerged from the empirical data. Here ‘comprehending the plot’ refers to a student understanding the story-line by being able to follow and understand what happens.

Due to the fact that the films and TV series produced in the U.S.A. and the U.K. are *foreign* media programs to the Chinese college students, simply comprehending the plot appears to be very challenging. Without being able to understand the story-line, many of the attractions of film referred to in the previous section will not be present. The following section will provide illustration of this.

6.1 Comprehending the Plot

(Q.6.1.1)

Interviewer: 那他们怎么放电影? 说英文中文字幕还是英文字幕?

LAQ: 就是听的肯定是英文, 放的时候一般就是中文字幕。要不然就完全就不懂。

English translation:

Interviewer: So how do they play films? English soundtrack with Chinese subtitles or English subtitles?

LAQ: Definitely English soundtrack, normally with Chinese subtitles. Otherwise I cannot understand anything.

(Q.6.1.2)

PP: 以前是说英语中文字母。这段时间, 就是想练听力嘛, 就是说英语没有字母。

但是大部分都听不懂。哈哈(笑)，要多听好多遍。这段时间主要看 *Coyote Ugly*。也挺好看的。我都看了 3 遍了吧，还没全听懂呢。

English translation:

PP: In the past, English soundtrack with Chinese subtitles. At the moment, (I) want to practice listening skills, (watch with) English soundtrack with no subtitles. But I cannot understand most of it. Hahaha (laugh). Need to listen to many times. Recently, I mainly watch *Coyote Ugly*. It's enjoyable to watch. I have watched it three times and still do not understand completely.

- **English soundtrack and Chinese subtitles**

According to the interviewees, based on their experience, watching with *English soundtrack* and *Chinese subtitles* is the most common way of watching films produced in the U.K. and the U.S.A. (Here, films include both films and TV series.) There are two main reasons behind this. First, the comprehending the plot of the film appears to be very challenging without the help of Chinese subtitles. Many other interviewees indicated they encountered similar problems.

(Q.6.1.3)

Interviewer: 那你们如果看英文和英文字幕，你们看得懂吗？

S1: 我看过电影频道的，看过一两次，看不下去。哈哈。因为它那个，本身我英文也不是特别好，因为是，日常说话，可能就很快，特别是长的句子带连读什么的，本来就是英文，然后还特别快，根本就是看不懂，有的地方就很模糊，如果在电脑上看，来来会回还可以再看看。电影频道就不行，放了后就没了。

S2: 我正好看了一部英文电影，中文和英文字幕都没有。就是很小很小的句子都还懂，然后就主要看情节。而且那部电影是我小时候看过的，我知道情节，我偶尔能听的懂几句小的句子，心里面还有点窃喜，但是长的句子就不懂了。

English translation:

Interviewer: If you watch with English soundtrack and English subtitles, can you understand?

S1: I have watched Movie Channel once or twice. Couldn't understand and couldn't keep watching. Hahaha. Because my English is not particularly good, it's daily conversation, and very fast with long sentences etc. I completely could not understand because it's in English and very fast. And some bits are very confusing. If I watch on my computer, I can watch it again. But (I) cannot do the same with the Movie Channel, once it's finished, it's gone.

S2: I just watched a film with English soundtrack with neither Chinese nor English subtitles. I could only understand very, very short sentences. After a while, I mainly paid attention to the story. Actually I watched that film when I was little, so I knew the plot. Sometimes I was able to understand a few short sentences, which made me feel happy inside, but when the sentences were long, I couldn't understand.

(Q.6.1.4)

JT: 我原来在家试过，就是 DVD 嘛，就是把字幕全调掉了，然后就看那个片子，然后我发现，有些时候能听得懂，因为有画面嘛，大概知道他在赶什么，然后如果他的话很简短，[...]有些听的懂，但是如果他说的很长很长的话，能听懂单词都已经满困难的了，然后就只能看一下画面了。

English translation:

JT: I tried once at home by using a DVD. I watched the film with no subtitles. I found that sometimes I could understand what they were saying because the pictures let me know basically what they were doing. If they used simple short sentences, I could

sometimes understand. But if they spoke very long sentences, it was already very difficult to understand the words, not to mention sentences. I could only look at the pictures.

The three student comments above indicate that the main challenge for these students when viewing English films was their English language proficiency. The length of the sentences, the intensity and the speed of the dialogue appear to be the main issue for these students. Full comprehension of the plot was very challenging with no subtitles. Hence, while listening to the English soundtrack, the Chinese subtitles play an important role in terms of assisting their comprehension of the plot of the film.

In addition to assist plot-comprehension, the second reason for viewing the film with Chinese subtitles was to improve their English, in particular their listening comprehension. This appears to be a commonality among these interviewees.

(Q.6.1.5)

DYY: 因为大多数是从网上荡下来的, 所以, 大多数是说英文看中文字幕. 我比较希望是说英文, 英文字幕. 有时候说的太快了听不太清楚. 有时候看一下字幕的话会比较清楚. 还是主要出于学习英语的目的.

English translation:

DYY: Because most (of the films) are downloaded from the internet, hence, most of them have English soundtrack and Chinese subtitles. I would like (to watch) with English soundtrack and English subtitles. (But) sometimes the speaking is too fast and I cannot hear very clearly. Sometimes it is clearer if I look at the (Chinese) subtitles. Still, my main purpose is to improve English.

(Q.6.1.6)

XY: 因为我第一遍的时候是用中文字幕看的嘛, 基本上我知道它大概的故事, 然后第二遍我调成英文字幕的话我可以了解里面一些比较地道的表达方法。

English translation:

XY: Because when I watch it with Chinese subtitles the first time, I understand the general story. Then, the second time, I use English subtitles so that I can understand and learn some authentic expressions.

The above comments have shown that there are two main reasons why students like viewing films with English soundtrack and Chinese subtitles. The first is to assist with plot comprehension. The second is to improve English proficiency. Based on the students' experience, watching films and TV series produced in the U.K. and U.S.A. is challenging due to the English language level. They heavily rely on the Chinese subtitles while using the English soundtrack. Without the Chinese subtitles, it is very challenging for them to achieve even basic comprehension of the plot of the program that they watch.

- **Plot comprehension: challenging**

As mentioned, during the interviews 23 clips (eight films and one TV series) were shown to the interviewees in order to find out how they made sense of them. Three to four clips were shown for each interview. Empirical findings indicate that students sometimes encountered great difficulty when it came to comprehending the basic plot of the film, due to language level. For example, the clip *Shop for gun*¹⁵ was shown to the interviewees in several different interviews. None of those interviewees had seen the film before. The clip was shown with English soundtrack and Chinese subtitles.

(Q.6.1.7)

(After viewing the clip for the first time)

LAQ: 没明白。

Interviewer: 没明白? 为什么?

LAQ: 不知道他们干吗要买枪。

Interviewer: 是因为他们说话快吗?

LAQ: 是很快。

Interviewer: 你知道他们说什么吗?

LAQ: 看字幕。还有就是他们为什么要用阿拉伯语说，一会又用英语说。不是太明白。

Interviewer: 那你看完第一遍对它的理解是什么? 能不能大概说一下?

LAQ: 就是两个人来买枪，然后由于种种原因，他们俩就是商量到底是买还是不买，还是买哪种。然后那个老板就急于想卖出去吧？然后就让他们俩商量，到旁边商量去。然后那个男的觉得老板不耐烦啊，侮辱他啊什么的，就吵起来了。

English translation:

LAQ: (I) don't understand.

Interviewer: Don't understand? Why?

LAQ: (I) don't understand why they want to buy a gun.

Interviewer: Is it because they speak too fast?

LAQ: They do speak very fast.

Interviewer: Do you understand what they said?

LAQ: Use (Chinese) subtitles. Also, why do they speak in Arabic, and sometimes speak in English? Don't quite understand.

Interviewer: What is your understanding of the clip? Can you please explain a bit?

LAQ: Two people want to buy gun, then due to various reasons, these two are discussing whether to buy or not, or which kind to buy. Then perhaps the owner wants to sell quickly? Then asks these two to discuss somewhere else. Then that man feels the owner is not patient, insult him etc. Then (they) start arguing.

Although there were Chinese subtitles, it was still very difficult for LAQ to fully comprehend what happened. The clip was shown to her for the second time to see if it made any difference.

¹⁵ Shop for gun: this clip was chosen from American film *Crash* (2004). In this clip, two customers (father and daughter who is in her 20s), who are Iranian immigrants to the U.S.A., want to buy a revolver in a gun store. They talk to each other in Persian, an Iranian language. The shop owner (a middle aged white man) behind the counter has an argument with one of the customers (father). The argument between the two is full of issues on races and 911. The father ended up leaving the store unwillingly. The shop owner sells the gun to the daughter.

(Q.6.1.8)

(After viewing the clip for the second time)

LAQ: 还是没太明白。这两个人是阿拉伯人吧？后来加入美国国籍了。然后但是那个老板知道他们是阿拉伯人以后...两个国家以前有过冲突吗？阿拉伯国家和美国原来有过什么冲突吗？

English translation:

LAQ: (I) still don't quite understand. Are these two people Arabic? Join American nationality later. Then, after the owner knew they are Arabic... are there any conflicts between these two countries? Has there been any conflicts between Arabic countries and the States in the past?

It seems that viewing the clip for the second time with Chinese subtitles, LAQ was able to understand a bit more (the customers were immigrants to the U.S.A.), but still did not follow the storyline. There are two possible reasons behind this. First, this clip is dialogue-intense. Characters speak very fast with emotions and without much body language. Hence, even with the availability of the Chinese subtitles, the high speed dialogue was difficult for LAQ to follow. Second, LAQ's existing knowledge of the context of what happened in the clip might be another factor, including different groups of immigrants and racial issues in the U.S.A., and the 911 incident, which was mentioned by the shop owner when he was arguing with the middle-aged Persian immigrant.

LAQ was not the only interviewee who found this clip difficulty to follow. After viewing the clip for the first time, SYY said:

(Q.6.1.9)

SYY: 不是很懂，因为我刚才一直在注意他那个...我一直想听他讲英语，又觉得他讲的不是英语，就同时就是觉得有一点混乱。

Interviewer: 你懂了多少？

SYY: 说实话不是很懂。

Interviewer: 你的理解是什么？

SYY: 我的理解就是，就是两个人去买枪嘛，那不过他没有办法拿定主意想买哪一种嘛，那那个就是特别生气嘛，那那个男的就...她老爸，他就是说不要买了...是吧？这女的就是还想做一些协商，不过她也不是说特别坚决吧我觉得。

Interviewer: 那那个卖枪的呢？

SYY: 那个白人胖子不象中国的商人的特点就是一定要把这个东西卖给你嘛。他在乎的不是利润嘛，在乎的就是说...这个东西...就是说他做这比生意到底高兴不高兴吧我觉得。

Interviewer: 那你说他为什么突然间就发火了？

SYY: 是不是因为他们没有拿定主意呢？是这样吗？

Interviewer: 她爸爸后来就发脾气，你知道他为什么发脾气？

SYY: 是不是关于歧视之类的？可能是关于这方面的东西。我实在没看懂这个东西。

English translation:

SYY: (I) don't quite understand because I kept paying attention to ... I kept listening to him speaking English, and then felt he did not speak English, then (I) felt a bit confused at the same time.

Interviewer: How much do you understand?

SY: My understanding is, two people went to buy gun, but he couldn't decide which kind to buy, that one got angry, that guy ... her dad, he said he did not want to buy... is that right? This girl still wanted to discuss, but she was not very determined, I think.

Interviewer: What about the one who sell the gun?

SY: That white fat guy is different from Chinese business men who really want to sell you this. He doesn't care about profit, he cares ... this ... he cares about whether he is happy to do this business or not, I think.

Interviewer: Then can you tell me why he got angry suddenly?

SY: Is it because he couldn't make up his mind? Is it right?

Interviewer: Her dad got angry later, do you know why?

SY: Is it about racial discrimination? Perhaps it's about things in this aspect. I honestly don't understand this clip.

(After viewing for the second time)

Interviewer: 这一遍呢?

SY: 差不多理解了。因为他本来讲的不是英语嘛，所以说他就觉得他不是美国的公民啊，就没有，可以说没有那个...没有条件来买枪吧。是这样吗？所以说不卖给他枪吧。那不过，首先在买枪的时候他们两个就拿不定主意吧？所以他们就在商量嘛。所以就引起冲突了，这样。

English translation:

Interviewer: How about this time?

SY: More or less understand. Because he (customer) did not speak English, hence, he (owner) felt he was not American citizen, then cannot ... cannot erm ... afford gun. Is it right? Hence, (owner) refused to sell the gun to him. But, first of all they (two customers) could not make p their mind, right? Hence, they were discussing with each other. Hence, the argument.

Both LAQ and SY identified great difficulty in understanding the clip. SY seemed to understand a bit more than LAQ after viewing the second time. However, neither of them was able to fully comprehend what happened. One thing worth pointing out is that, as underlined statement above from SY shows, SY identified differences between the shop owner in the clip and Chinese business men. What she did was more than 'comprehending the basic plot'. This will be further discussed at the end of this section.

The clip was also shown to a group-interview of three girls and one boy. None of them had watched the film before. After viewing the first time, they said:

(Q.6.1.10)

S3: 我没看明白。

S2: 是不是，他买枪，然后他们两个说话然后语言不是很通，然后就吵起来了？

S1: 他们是不是两个阿拉伯人？然后听不懂，然后很急的要卖给他们，又不回他话，就产生(S2: 误会)误会了？

Interviewer asks S3: 你呢?

S3: 没看懂。

Interviewer: 为什么呢? 是不是因为看不到字幕?

S3: 啊

S2: 基本上看不清楚，很快。

Interviewer: 那你们说老板的态度如何?

S2: 不好。

Interviewer: 为什么不好?

S2: 他们两个是黑人吗?

S1: 种族关系吧?

S3: 他们两个也是白人啊?

S1: 他们是黄种人好象是。

S2: 他们两个不是白人啊?

S1: 他们两个是阿拉伯人。(S2: 黄种人?) 肯定不是美国人

S2: 那就是说是外来异族啊, 那可能是种族方面的问题啦。

S1: 美国人就是这个方面比较有特点。

[...]

S4: 我感觉它和这个 911 事件有关。因为他要去买枪, 老板听说他是阿拉伯人, 就拒绝把枪卖给他们。说他是用 717 飞机去撞他们的楼, 说他可能就是...由于 911 时间引发的那种美国民族和阿拉伯民族之间的仇恨, 虽然, 他们在买枪, 其实阿拉伯人也很憎恶卖国对他中东地区一直以来的插手干涉。就是, 民族上的矛盾在他们两个人的个体之间发生了很激烈的碰撞。

English translation:

S3: I don't understand.

S2: Is it, he (wanted to) buy gun. Then they couldn't communicate because of language. Then started arguing?

S1: Are these two Arabic? Then, (the owner) couldn't understand but really wanted to sell (the gun) quickly, then (S2: misunderstanding) misunderstanding occurred?

Interviewer asks S3: What do you think?

S3: I don't understand.

Interviewer: Why? Is it because of subtitles?

S3: Yes.

S2: Too fast, I basically couldn't see them.

Interviewer: What do you think about the owner's attitude?

S2: Not good.

Interviewer: Why not good?

S2: Are those two black?

S1: Is it racial problems?

S3: Are those two white as well?

S1: They seem to be yellow.

S2: Aren't they white?

S1: They are Arabs (S2: yellow?) definitely not Americans.

S2: That means (they are) foreign race. Then it's definitely racial problems.

S1: Americans are particularly well-known in this aspect.

[...]

S4: I think this is relevant to 911. Because he wanted to buy gun, owner realised they were Arabic, then refused to sell the gun to them. (The owner) said he (customer) used 717 airplane to crush their building. Accused he (customer) is...due to 911 which caused the hatred between Americans and Arabic. Although, they buy gun, actually, Arabic also hate Americans' interferences in the Middle East all this time. The conflicts between two national groups caused the intensive clashes between these two individuals.

Like LAQ and SYY, in this group three students showed great difficulty in comprehending the clip even with the help of Chinese subtitles. Also, it is worth mentioning that S3 and S2 showed difficulty when they tried to identify the two customers' racial identity. Comparatively, S1 did

better, although her guess was wrong¹⁶. S4 stood out among the four. S4's English proficiency appeared to be better than the rest of the three because he was able to follow most of the dialogue. Another factor seems to be related with the relevant cultural background knowledge, in particular, racial issues and incident 911.

(Q.6.1.11)

(After viewing the second time)

Interviewer: 这次如何?

S1: 我觉得好象他可能是因为, 应该是文化的差异吧。因为他一开始, 他们两个在讨论, 然后老板不知道他们买不买, 然后才发生矛盾。就是因为发生矛盾以后大家心理不开心, 然后老板才会讲关于恐怖事件的事情。

S3: 差不多。

S4: 就是我感觉他一开始可能不知道他是阿拉伯人, 但是一听到他是阿拉伯人才...有开始还想把强卖给他, 说买什么私下讨论, 想卖给他。后来他们用阿拉伯语讨论, 老板体会来, 所以我就不卖了。

S1: 他刚刚不是, 是那个卖枪的人先引起来的。他一开始可能以为老板就是跟他声音大声一点可能因为他是种族歧视, 因为大家都知道美国人种族歧视是很严重的, 他们又不是这个国家的人, 然后发现那个老板一下子对他声音很大的话, 就以为种族歧视。是客人觉得种族歧视然后他们才那个的。

English translation:

Interviewer: What about this time?

S1: I think perhaps it's because, perhaps it should be cultural differences. Because at the beginning, he, they were discussing, then the owner didn't know whether they wanted to buy or not, then the conflict started. Because everyone wasn't happy due to the conflict, that's why the owner talked about the terrorists incidents.

S3: Maybe.

S4: I think he (owner) didn't know he's Arabic at the beginning, but only heard he was Arabic then ... (owner) wanted to sell the gun to him at the beginning, said something like discuss in private, wanted to sell it to him. Later (two customers) talked in Arabic, then the owner realised, then I (the owner) don't want to sell.

S1: Didn't he, the person who wanted to buy gun, cause (the argument) first? At the beginning he thought the owner talked to him in a louder voice, thought he's racially discriminating, because everyone knows Americans have serious racial discrimination, they (two customers) are not people from this country, then found that owner suddenly talked to him in very loud voice, then believed it's racial discrimination. It's the customer felt being discriminated against, then they started that.

The second-time viewing helped S1 gain better understanding of what happened. However, S2's and S3's reaction did not seem to indicate any better understanding of the clip. Comparing S1 and S4, although they both managed to follow the basic story-line, it seems that they had slightly different views on the cause of the argument between the owner and the customer. What they did is more than 'comprehending the plot'. What they did was to try, based on a basic comprehension of the plot, to interpret character's action by applying their own views and relevant knowledge, including Americans, conflicts between the U.S.A. and Arabic countries, and a

¹⁶ The two customers are Iranian immigrants to the States and speak Persian to each other. In the film, they were mistaken by others as Arabic as well because of the stereotypes. Hence, S2's 'mistake' is understandable.

stereotype of Americans (racial discriminators). In doing so, the character's action makes sense to them.

Although the above data shows the great difficulties students encounter in comprehending the basic plot when they view a clip from an English film that they had never seen before, other findings suggest this is not always the case.

The clip, *Step off*¹⁷, was chosen from the American film, *School of Rock* (2003). Unlike other films, I could not find any DVD with Chinese subtitles. Hence, I showed the clip at two individual-interviews and one group-interview with English subtitles on. None of them had watched the film before. Before viewing, they were given the option of viewing the clip with or without English subtitles. They all asked for English subtitles because of lack of confidence of viewing without any subtitles. Below is that happened after they viewed the clip for the first time.

(Q.6.1.12)

Interviewer: 我给你放一个片段，看看你能看懂多少。你要英文字幕吗？

SYY: 要吧，要不然太挑战了。

[...]

(After viewing)

Interviewer: 这个片段没有中文字幕，只有英文字母，你看完片段后，你大概懂多少？

SYY: 100%懂，可以这样说。

Interviewer: 不错嘛！

SYY: 我觉得比较简单我觉得。

Interviewer: 你说100%是？

SYY: 这个片段我觉得还是比较简单吧我觉得。不管语言方面还是表达意思方面都明白了。... 比如说刚才那个小男孩，他老爸还是对他有点担心的嘛，[...] 不过我相信全班的同学都会喜欢上这个老师的。

English translation:

Interviewer: I will show you a clip, see how much you can understand. Do you need English subtitles?

SYY: Yes, otherwise it's too challenging.

[...]

(After viewing)

Interviewer: This clip doesn't have Chinese subtitles, only English subtitles, how much do you understand after viewing it?

SYY: 100% understand, I can say.

Interviewer: Not bad!

SYY: I think it's relatively easy.

Interviewer: What do you mean by 100%?

SYY: I think this clip is pretty easy. I understand both language and the meaning. For example, the little boy, his dad is a bit worried about him, [...] I believe all students in the class will fall in love with this teacher.

¹⁷ Step off: a clip chosen from the film *School of Rock* (2003). In the clip, a substitute teacher, who used to be member of a rock band, saw a boy was criticised by his father before he entered the school in the morning. He then tried to encourage students to express their anger and unhappiness through rock music.

(Q.6.1.13)

S1: 就是让他们把想法都表达出来, 把烦恼都抛开吧。我觉得是那个意思。

S4: 师生之间的方式挺开放, 挺活泼的。

English translation:

S1: (The teacher) encourages them to express all the thoughts, get rid of all the troubles. I think that's what it's about.

S4: The relationship between the teacher and the students is fairly open and lively.

(Q.6.1.14)

DC: 100%懂, 可以这样说。有一些短语可能不明白, 但不影响理解。就是 Zac 父亲跟他说 Rock music 只能在学习之后。他就很失落, 正好被那个老师看见了。老师就用自己的方法帮助小孩认识 Rock music 的真谛, 帮助他重新振作。

English translation:

DC: 100% understand, I can say. Perhaps cannot understand some of the phrases, but does not affect comprehension. Zac's dad told him that Rock music comes after study. Then he (Zac) felt blue, and was seen by that teacher. Then the teacher used his own method to help the kids understand the spirit of Rock music, to cheer him up.

There is a clear contrast, in terms of comprehending the basic plot, between the clip *Step off* and the clip *Shop for gun*. Both of the clips were new to the interviewees. In terms of *Shop for gun*, many of them could not follow the plot even after viewing with Chinese subtitles. Some of them needed to view more than one time. However, all the interviewees managed to comprehend the plot of *Step off* even without Chinese subtitles. Some students clearly showed different levels of understanding of these two clips (i.e. SYY and S1).

What makes this difference? Let us look at some more clips.

Among the 23 clips, the clip *Shop for gun* appeared to be the most difficult. Another clip, *Director*, from the same film, *Crash (2004)*, was shown to four individuals, who had never seen the film before. Three of them managed to understand the basic plot with the help of Chinese subtitles. One of them indicated the clip was too difficult. Another clip, *Two black men*, from *Crash (2004)*, was shown to two interviewees who had not seen the film before. They managed to follow the plot but indicated difficulty in following the dialogue. Clips from *Titanic (1997)* appeared to be easy to comprehend because all interviewees had seen the film before. The clips from *American Pie (1999)*, including *A father-son chat*, *Stifler's party* and *Prom*, appeared to be easy to comprehend, although the interviewees had not watched the film before. However, one student watched part of *American Pie Presents Band Camp (2005)*. All interviewees indicated the clip, *London bench day*, from *Love Actually (2003)* was easy to comprehend, although none of them had watched the film before. Four out of ten interviewees indicated that the dialogue between Chandler and his friends and the dialogue between Chandler and Aurora in the clip from *Friends*, *Chandler's date*, was too difficult to follow. Another clip from *Friends*, *Phoebe calls London*, was shown to two interviewees who appeared to have difficulty identifying the nationality of Emily's

housekeeper. The clip *Rachel doing laundry*, from *Friends*, was shown to two interviewees. Both of them managed to comprehend the plot without necessarily understanding all the dialogue.

To sum up, the above findings indicate that watching a foreign English film is not always an easy task for these Chinese college students. Some films are difficult and some are relatively easy. Students heavily rely on Chinese subtitles. Due to the English language level and level of existing relevant cultural background knowledge, comprehending the plot sometimes appears to be challenging. Even with the help of Chinese subtitles, viewing only once does not always guarantee plot comprehension. Different levels of English proficiency and existing background knowledge affect students' level of comprehension. However, not being able to understand every single word does not necessarily mean being unable to follow the basic story-line, due to the fact that students can also obtain information from the images.

Possible variables which affect students' ability to comprehend the plot of films have been identified. The first is the student's English language proficiency, which affects to what extent a student can comprehend a clip with or without Chinese subtitles. The second variable deals with students' existing knowledge (including stereotypes) of the relevant cultural background and his/her personal views. The third factor is whether or not the student has watched the film before. A clip tends to be a lot easier to comprehend if it's been watched before. However, not having watched a film before does not necessarily make a clip difficult (i.e. *Step off*). The fourth variable has to do with the *subject* the content of the clip touches upon. It seems that the clips which appear to be relatively easy for students to comprehend are the ones which deal with subjects that students seem to be familiar with, such as father and son (i.e. *A father-son chat*, *London bench day*), teacher and students (*Step off*), racial issues between White and Black (i.e. *Two black men*, *Director*), relationships between men and women (*Chandler's date*, *Rachel doing laundry*), and differences among classes (i.e. *Women and children first*, *Dining saloon*). Clips which deal with subjects which are less familiar to students tend to be more difficult to comprehend, such as different racial groups in the U.S.A. (i.e. *Shop for gun*). In addition to the issue of the subject, another factor is the balance between the intensity of the language (vocabulary, length of sentences, dialogue and speed) and the visual images (setting, body movement). The final variable is whether the student watches the clip alone or with others, such as with classmates and flatmates. As discussed, students do not always have unified comprehension of the same clip. Their understandings may influence each other on various levels.

As discussed, making sense of films often involves more than comprehending the plot. For example, SYY (Q.6.1.9) identified differences between the U.S.A. culture and the Chinese culture by comparing the character (shop owner) and Chinese businessmen. Based on the empirical

findings gathered from participants, in addition to ‘comprehending the plot’, ‘Compare: identifying differences’ appeared to be another major category of activities involved in making sense of films produced in the U.K. and the U.S.A. This will be the focus of the following section.

6.2 Compare: Identifying Differences

In terms of how Chinese college students (CCSs) make sense of foreign films, identifying differences through comparison sense-making activities is one of the major categories. During the process of data analysis, it gradually became apparent that what CCSs do is more complex than merely identifying the differences. They conduct this type of sense-making activity on three different levels. Each level will be illustrated by findings from the empirical data.

- Compare: identifying differences: fictional character(s) and self/significant individual
- Compare: identifying differences: fictional character(s) and Chinese people in general
- Compare: identifying differences: generalised group of people represented by fictional character(s) and Chinese people in general

6.2.1 Compare: Identifying Differences: Fictional Character(s) and Self/Significant Individual

Having watched the clip *Stifler's party*¹⁸, PWB said:

(Q.6.2.1.1)

PWB: 这种形式就是特别好，那个家里特别大，请很多人来，也不胡闹什么的。象我们现在，平时聚会都没地出去玩，除了吃顿饭，唱歌就没什么事了，然后觉得特别单调，人家这个挺有意思的，说会话啊什么的。

English translation:

PWB: This kind of activity is very good. That home is very big, (Stifler) invites a lot of people, and they don't make a mess. Look at us now, usually we have no place to have fun. Apart from having meals together and singing songs, there is nothing else to do, and I feel very bored. They seem to have fun, chat together etc.

PWB compared the characters with himself, and identified differences between how the high school students socialise with each other in the clip and his own experience of socialising with his friends. As a result, PWB seems to admire what happens among the fictional characters in the clip.

I showed another clip, *London bench day*¹⁹, to two female students (JT and TXH). Having watched the clip, JT talks about the 11-year old boy, *Sam*, from the clip.

¹⁸ *Stifler's party*: a clip chosen from film *American Pie* (1999). In the clip, Stifler hosts a party in his mom's house. Many high school students come to attend his party. Several boys who are Stifler's friends attempted to get girls' attention unsuccessfully.

¹⁹ *London bench day*: A clip chosen from British film *Love Actually* (2003). In the clip, the 11-year old boy Sam sits on the same bench with his step-dad. Sam's mom just passed away. Sam has been very upset. His step-dad decides to have a chat with him to find out what troubles him. Sam confessed that he's in love with a girl.

(Q.6.2.1.2)

JT: 用中国人的话，就是早熟。我以前有一个同学的弟弟，他也是是在 10 几岁的时候教女朋友啊什么的。但是我觉得完全跟他不一样，他会用爱这个词，说我爱上了一个人，会为此而烦恼，他觉得这是一个很男中的问题，觉得很痛苦，但是那个小孩那就是想找一个女孩子，为了谈恋爱而谈恋爱，完全不是一回事，觉得那种很幼稚，小孩子玩游戏，过家家，但是他就是真的已经谈论到什么爱啊，爱情那方面，就不太一样，深度也不一样。

English translation:

JT: In Chinese people's saying, this is precocious. I used to know a younger brother of my ex-classmate. He also had a girlfriend when he was about ten. But I think he is completely different from him (Sam). He (Sam) used the word love and said I'm in love with a person. He's worried because of this. He thinks this is a very serious issue and feels pain. But that child (ex-classmate's brother) just wanted to be with a girl, and went out with her for the sake of dating. That's completely different. I think that's very childish, children playing games and playing families. But this boy is really talking about love, feelings etc. It's very different and it's different in terms of depth.

JT responded to the character, Sam, quite strongly. In addition, JT compared the fictional Sam with a real Chinese boy (the younger brother of her friend) based on her understanding and views of their attitudes towards dating and love. JT identified the differences between these two boys in terms of their attitudes towards dating, as well as how serious they were in their feelings towards their girlfriends as the result of comparison. She has not thought about the fact that Sam was playing a part created for him by an older writer, rather than representing the typical behaviour of a U.K. 11 year old boy.

Another female participant TXH said:

(Q.6.2.1.3)

TXH: 而且，这个小孩很有意思，可以和他爸爸这么直接的表达。一般中国家庭之间的沟通不会那么直接。现在，在中国，可能父母和子女一般不会谈论爱情，像这么小的时候，像我父母和我就没有谈过，其实他们认为孩子应该在恰当的时候做恰当的事情，可能不能理解小的时候就会理解有这种感情吧。

English translation:

TXH: Also, this child is very interesting. He can express himself to his father so directly. Normally, in Chinese families, communication would not be this direct. In China, probably parents and children would not talk about dating. For example, when I was this little, my parents had never talked to me about this before. Actually, they think that children should do the appropriate things at the appropriate times. They probably would not understand young children would understand and develop this kind of feeling.

Like JT, TXH also responded to the same character, Sam. Unlike JT, TXH was impressed by the communication between Sam and his dad, and the fact that Sam told his dad about being in love with a girl. According to TXH, Chinese parents normally would not talk about dating with their children in such direct way. She took her own experience as an example and compared the communication between herself and her parents with the communication between Sam and his father, and specifically the two generations talking about dating. She also gave an explanation as

to why her parents did not talk to her about dating, as if she shared that understanding with her parents.

The above two text extracts show that JT and TXH both responded strongly towards the character, Sam. Although they both reacted to the same character, they were impressed by different things which happened around Sam. TXH compared Sam with herself, and Sam's dad with her parents, in terms of communication between two generations on dating issues. JT compared Sam with another young boy whom she knew went out with a girl.

Having reviewed the above interview extracts, what do they tell us?

First, as the above examples show, 'identifying differences' is another main category which has emerged from the qualitative data with regard to Chinese college students (CCSs) making sense of films and TV series produced in the U.K. and the U.S.A. Usually students identify differences by comparing the characters with themselves, comparing characters with other significant people in their lives, such as parents and partners, and comparing characters with other people whom they know. In short, CCSs identify differences by comparing one or more fictional characters to self or Chinese people who are closely related with self in the Chinese context.

Secondly, the Chinese people with whom CCSs tend to compare characters with are the individuals who in real life share something in common with the characters. For example, the Chinese boy whom JT compared Sam with shared things in common with the character Sam. They both were boys who went out with girls at a similar age.

Finally, CCSs' existing knowledge and life experience play an essential role in the process of identifying differences.

Before moving forward to the next section, let us look at TXH's comments again (Q.6.2.1.3). In addition to TXH comparing Sam with herself, TXH compared Sam and his father with Chinese families in general by saying: "normally, in Chinese families, communication would not be this direct. In China, probably parents and children would not talk about dating". However, what she was doing at that time was to mainly compare Sam with herself. Her generalized view and understanding on communication between children and parents in Chinese families was mostly developed from her personal experience with her parents. However, TXH's comparison between Sam and his father and Chinese families in general may still be valid.

The following section will consider examples where CCSs make sense of films by identifying differences between character(s) and Chinese people.

6.2.2 Compare: Identifying Differences: Fictional Character(s) and Chinese People in General

(Q.6.2.2.1)

GW: [...] 而且, 他们 6 个人之间也有很复杂的感情问题, 这两个人在一起, 然后又分开, 然后又在一起。我就觉得在中国一般两个人在一起, 然后分开, 再见面都很尴尬, 他们还可以这样, 象没事一样, 一面可以共同生活, 还可以再符合。我就觉得挺不可思意的。

English translation:

GW: [...] Plus, there's also complex love issues among those six. The two get together (Rachel and Ross), and separate, and get together again. I think, in China, normally, after two people get together and then separate, they would feel embarrassed when they meet again. They (Ross and Rachel) can still act like nothing happened, and live together, and then can get back together again. It's beyond my imagination.

As the result of comparison, GW identified differences between the fictional characters Rachel and Ross (from American sitcom *Friends*) and Chinese people in general, rather than identifying differences between these characters and particular individuals, such as herself or people close to her in the Chinese context, which happened in the examples presented in the previous section.

I showed the clip, *Chandler's date*²⁰ from the same show, *Friends*, to a group of four CCSs. After viewing the clip, they said:

(Q.6.2.2.2)

S1: 他们没什么忌讳, 想说什么就说什么。

S3: 没错。我觉得中国一帮男的女的住在一起肯定不敢这么说。

S1: 对阿。

S2: 肯定隐藏。自己跑到屋子里想一想啊。(S3: 对阿) 要不然找一个知心的朋友说两句。

English translation:

S1: There's no taboos. They say whatever they want to say.

S3: Exactly. I think a group of Chinese men and women would definitely not dare to talk like this.

S1: yah.

S2: I definitely would hide. Stay in my room alone and think things over. (S3: Yah) Or find a good friend and say a few words.

In the view of the CCSs, the characters have no restraints on what they talk about. (This mainly refers to Chandler talking to his friends about his date with a woman called Aurora, who has told him she only wants to maintain a sexual relationship with him, as she is married and also has a boyfriend.) The discussion among the CCSs recorded above shows that they compared the characters, five friends, with an equivalent group of Chinese friends of men and women. In particular, they identified differences between the way the five fictional friends talked to each

²⁰ Chandler's date: a clip chosen from American sitcom *Friends* (1994-2004). In the clip, Chandler's shares his experience of his date with a beautiful Italian woman who has already been married and has a boyfriend at the same time. The woman, Aurora, only wants a sexual relationship with Chandler. Knowing the situation, Chandler decides to keep dating Aurora.

other about Chandler's date with Aurora, and the way that an equivalent group of Chinese friends would discuss (or not discuss) the same situation.

After viewing the same clip, JT said:

(Q.6.2.2.3)

JT: 我觉得... 他 (Chandler)会对自己的朋友也会说起这件事。在中国应该不会把这些事情宣扬。而且, 我觉得...可能男的可能会有一点大男子主义, 他们不会接受自己的女人有别的伴侣。基本上不可能有这种现象。 [...]

English translation:

JT: I think ... he (Chandler) also tells his friends about this thing. In China, people would not publicize these things. Also, I think ... probably, Chinese men are a bit male chauvinistic. They would not accept their woman having other partners. Basically, it's impossible for things like this to happen. [...]

JT reacted strongly towards the fact that Chandler shared his experience of dating Aurora with his friends. Regarding discussing relationship issues with friends, JT compared Chandler with Chinese men in two aspects.

First, according to her, Chinese men would not 'publicize these things'. Interestingly, JT used the word 'publicize'. This indicates, from JT's point of view, how private issues such as personal relationships are. This means, based on JT's knowledge of Chinese men, things like having a casual sexual relationship with a woman who is married are too private to be shared with others, even with friends.

Second, another aspect JT compared Chandler with Chinese men was maintaining a sexual relationship with a woman who had other sexual partners at the same time. According to JT's knowledge of Chinese men, they would not do that as they tend to be a bit male chauvinistic.

The above two examples show that, rather than identifying differences between characters and self or other specific individuals who are related to self, some CCSs identify differences between characters and a group of Chinese people. However, they do not identify differences between characters and just any group of Chinese people. They identify differences between characters and a particular group of Chinese people who are similar or equivalent to the characters in some way. For example, in the case of the clip *Chandler's date* from *Friends*, JT compared Chandler with single Chinese men. S1 and S2 compared five friends (three male and two female) with a group of Chinese friends of men and women.

Let us look at another example from GW. During the interview, when asked to talk about films or TV series that she has watched before, GW mentioned one of her favourites, the American TV

series *Growing Pains*²¹. (This TV series was produced in the 1980s. The program told stories about an American family as the children grew up, focussing on the relationships between the children and the parents.) After first explaining what the TV series was about, she talked about one episode which had left her with a deep impression.

(Q.6.2.2.4)

GW: 它那个电视剧就是讲的一家人，然后几个孩子在一起，小孩子，恋爱，烦恼，经常成长中的烦恼啊那些。比如说那个小孩子，处于青春期成长发育当中吧，她想那个买那个 Bra，然后象那种事情她爸爸妈妈就会跟她细心交流啊，帮她去商店给她挑选啊。我觉得在这个方面吧，特别是在那个方面中国家长还是比较保守的。她那个，家长愿意心平气和帮她去了解啊什么的。就她那个第一次月经，她妈妈都会很耐心跟她讲啊。我觉得这在中国简直不可能。我觉得触动挺大的。像一般美国人都很开放，那上面不仅母亲对那方面，女孩子进入青春期这方面教育挺关注的。而且她爸爸也挺关注她这方面的。跟中国的文化差异很大的。就是那一集感觉印象特别深。

English translation:

GW: That TV series is about a family with a number of children living together, young children, love, pain, pains suffered while growing up, etc. For example, one child, (she was) in the stage of adolescence and development, she wanted to buy a bra, and then, things like that, her dad and mom communicated with her carefully, went shopping and helped her choose a bra. I think, in this aspect, especially in that aspect, Chinese parents are fairly conservative. Her parents were calm and willing to help her understand etc. When she had her first period, her mom explained to her very patiently. I think this is impossible in China. This stirred my feelings greatly. Like, Americans, normally, are all very open. In that aspect, education for girls entering puberty, not only her mom pays close attention, but her dad also gave her a lot of attention in this aspect. There are lots of cultural differences from China. I have a fairly deep impression on that Episode.

Among all the films and TV series GW mentioned during her interview, she seemed to feel particularly strongly toward *Growing Pains*. She had a lot to talk about this TV series, and especially about the one particular episode. Although she watched it many years ago before she went to college, she still remembered what happened in this episode very clearly.

In the episode that she mentioned, GW talked about two things that happened to the daughter, buying her first bra and having her first period. GW was strongly impressed by the daughter's parents and their approach to their daughter concerning these two issues, and compared the fictional parents with her view of Chinese parents. In terms of bra shopping, the fictional U.S.A. parents were calm and willing to help their daughter understand, whereas, according to GW's knowledge, Chinese parents tend to be more conservative in this aspect. GW also felt particularly strongly about the fictional mother who explained to her daughter "patiently" when she had her first period. GW believed that Chinese parents would not do so. Perhaps GW felt very strongly

²¹ *Growing Pains* (1985-1992) is American TV series about series of adventures happen in one family. In the family, there are initially two boys and one girl with a psychiatrist father and a journalist mother. A baby sister is born during the series.

about this particular episode because of the strong contrast with her own experience of these two potentially traumatic events in a young woman's life.

In addition, GW viewed American people as all very open. It seems that this existing view and understanding of Americans in general played an important role in forming her understanding of the fictional parents' approach to their daughter, particularly in helping their daughter gain more knowledge about puberty. However, one can also speculate that GW's view on Americans was partly the result of watching this episode.

In addition, GW also commented on two of the main characters, the younger son and the elder daughter in the family. Later on in the interview, she said:

(Q.6.2.2.5)

GW: 而且他们在家还特别自由。那个女孩有一个小弟弟，跟她经常吵架。我觉得在中国家庭嘛，不要说就是两代人之间，就是长辈和晚辈，就是平辈之间比如说姐姐比弟弟妹妹大很多，弟弟妹妹也要对姐姐尊重。可是她的弟弟就拿她姐姐开玩笑啊什么的。这种关系感觉特别轻松吧。跟中国挺不一样的。

English translation:

GW: Plus, they are very free at home. That girl has a little brother who often quarrels with her. I think in Chinese families, not mention two generations, I mean, older and young generations, even the same generation, for example, if an elder sister is a lot older than brothers and sisters, brothers and sisters should respect the elder sister. But her brother makes fun of his sister etc. This kind of relationship feels very relaxed. It's quite different from China.

GW identified differences between the relationship between the brother and the sister in *Growing Pains* and the relationship between brothers and sisters in Chinese families. According to her understanding, the relationship between the brother and the sister in the program is relaxed. In comparison, the relationships in Chinese families, not only between two generations, but also between brother and sisters, emphasise respect.

In a group interview, student S2, who also had also watched *Growing Pains*, said:

(Q.6.2.2.6)

S1: 大一点以后看了 *Growing Pains*。这个讲的是家庭里面的故事，两个儿子一个女儿，3个孩子。讲的是... 可以看到他们父母怎么养育自己的孩子的。他们就是很开放，让孩子去做自己喜欢做的事情，然后对孩子很支持的。不像中国父母就是，中国父母在思想上去束缚孩子，他们更有一种朋友之间的感觉。可以互相沟通什么的。即使小孩和父母说说笑笑也不会成为什么问题，更能促进他们的友谊。

English translation:

S1: After I got older, I started watching *Growing Pains*. It's about stories in the family, two sons and one daughters, three Children. It's about ... how these parents raise their own children. They are very open, let children do things that they like, and very supportive to their children. Unlike Chinese parents, Chinese parents fetter their children's thoughts. They (in *Growing Pains*) feel more like friends, they can

communicate with each other etc. Even though the children chat and joke with the parents, this doesn't cause a problem, but rather enhances their friendship.

S1 identified differences by comparing the fictional parents with Chinese parents. She did so by explaining her understanding and views on Chinese parents' approach to their children, which, according to S1, was to "fetter their children's thoughts". The Chinese equivalent of the word 'fetter' is usually used with negative meaning attached, in the same sense as in English. For example, according to Oxford Advanced Learner's Dictionary, 'fetter' means to restrict someone's freedom to do what they want (2000:468). From her comments during her process of comparison, S1 seems to have positive attitudes towards the fictional parents. In contrast, her attitudes towards Chinese parents, and specifically their approach toward their children, appear to have more negative tendency.

Regarding the same clip, *London bench day* from *Love Actually* (2003), CJY said:

(Q.6.2.2.7)

CJY: 我觉得这个爸爸和孩子是平等的, 像朋友一样。有些问题会去讨论, 大家都是平等的, 然后后来沟通, 交流。而且和我们这边不一样。至少和我们大部分家庭都不一样。我们是一种家长制, 对吧, 他们那种还是, 就像朋友一样, 11岁, 就可以和父亲这样说话。我觉得这样定位很好的。就像朋友一样, 挺好的。

English translation:

CJY: I think this father and his child are equal, like friends. They discuss various issues on an equal footing and really communicate. It's not the same as here. At least, it's different from the majority of our families. We have a parental control system, don't we? They are kind of still like friends, (he is only) 11 years old, and can talk to his father like that. I feel this kind of relationship is very good. Just like friends, really good.

Like three other CCSs who viewed the same clip, CJY responded to the two main characters, Sam and his father, and specifically to the relationship between them. According to CJY, he perceived that Sam and his father were like friends, and that they communicated with each other. In CJY's view this was different to most families in China. His comparison is not directly with his own family, but with his understanding of Chinese families. In addition, his positive attitude towards the relationship between fictional dad and son indicates that, as a result of comparison, he was not entirely happy with the relationship between parents and children in Chinese family in general.

To summarize, the above examples illustrate that, as a result of undertaking comparison, in addition to identifying differences between characters and specific individuals in the Chinese context, CCSs sometimes identifying differences between characters and equivalent groups of Chinese people. CCSs do not compare with just *any* group of Chinese people, but with specific

groups of Chinese people who share certain things in common with the characters, such as gender, age, family position, position in society, occupation, etc.

Several variables play an essential role during the process of identifying differences. One of these is the basic information gained from plot comprehension and understanding of the characters. However, CCSs also apply their existing knowledge of Chinese people and China, as well as existing knowledge relevant to people in the character's position. What is more, CCSs apply personal experience and values and beliefs relevant to the characters and the events that happen around characters. By identifying differences through a process of comparison, when watching foreign films CCSs may reinforce or form positive or negative attitudes towards characters and towards the equivalent group of Chinese people (this point will be further explored in the next chapter).

6.2.3 Compare: Identifying Differences: Generalised Group of People Represented by Fictional Character(s) and Chinese People in General

(Q.6.2.3.1)

GW: 好象美国人不是单纯的看你的社会地位，而且是看你的中间那段努力的过程吧。中国人注重一个结果，比如说你混到了一个科级，处级，不会认为你一开始起点是那么低，在经过这么长时间达到这个水平已经是你付出努力。他们不会这么看。

English translation:

GW: It seems that Americans don't purely judge you based on your social status, what they also care how you got there. Chinese people only care about the result. For example, if you manage to become an executive or manager, (they) wouldn't care whether or not you started from a very low position, or whether or not you reached this high level by your own endeavour. They don't care about this.

Having watched the film *Forrest Gump* prior the interview, based on her understanding of the main character, Forrest, GW identified the differences in attitudes between American people and Chinese people.

The focus of this section is to illustrate the third type of 'identifying differences' activity, identifying differences between people represented by the character(s) and Chinese people. Let us look at some more examples collected from the empirical data.

DYY talked about the film *The Graduate* he had seen before.

(Q.6.2.3.2)

DYY: 就是这个男主角叫 Ben。他是一个美国人，[...]，他最后就会很直接的，很大胆的，很疯狂的去追求那个女朋友，不顾周围所有人的一种排斥一种诅咒，他会勇敢的追求自己的爱情。而且其实在中国来看的话，这简直是不敢相信的，我觉得国人还是偏向于传统思想，他不会直接的去表露，我觉得很少会有人这么大胆。

English translation:

DYY: This leading man is called Ben. He is an American, [...] In the end, he (*Ben*) very directly, bravely, madly pursues his girlfriend, regardless of all the people around and their rejection and taunts, he bravely pursues his love. However, really, as far as China is concerned, this is simply unbelievable. I think Chinese people still tend to be conservative, and they would not dare to reveal themselves. I think very few people would be this brave.

DYY responded strongly to the film, and in particular how the character Ben pursued his girlfriend. DYY believed that people in China would not do something this brave because, according to his view of Chinese people, they tend to be conservative. After comparing the character Ben with Chinese people, DYY then continued:

(Q.6.2.3.3)

DYY: 美国人他们会很独立，他们会有自己的思想，他们不会说，父母说，这件事情不对，而我认为这见事情是对的，因为父母说不对，所以我不去会去做，他们不会这样。他们会，很自我，很独立，我既然认为这件事情是对的，我就一定要去做。中国孩子的话，首先他肯定会，首先他周围的人对他的思维的影响会很大，如果说某个人说这件事情不对，而且说的是还是比较有道理，他们他可能就至少会，原来是 100%的一种情绪上去做，现在也可能是 50%了。像美国人他们就不会这样。

English translation:

DYY: Americans, they are very independent. They have their own thoughts. They would not say, "my parents said this is not the right thing to do, and so even though I think this is right, because parents said it's not right, I cannot do it". They are not like this. They can (be) ... very self-assured, very independent, "if I believe this is the right thing to do, I will definitely do it". However, a Chinese young person, first, he definitely would not ... firstly, people around ... will influence his ideas a lot, if someone says, this is not right and (this person) sounds quite reasonable, his determination will reduce, originally he was 100% determined to do it, now he is perhaps 50% determined. But Americans, they are not like this.

It seems that DYY's perception of Americans being independent and not easily influenced by their parents (in terms of pursuing things that they want) has a strong link with how he felt about the main character, Ben. In other words, he has made a link between the character Ben and bigger group of people who are from the same cultural context as Ben, the U.S.A. This is probably because DYY's understanding of the character Ben fits his existing perceptions of Americans, and, as a result, the character triggered and reinforced this existing perception of American people.

DYY identified particular differences by comparing American people with Chinese young people in terms of to what extent they would be influenced by others. Although he used the term 'Americans' during the process of comparison, it seems that he was more specifically referring to American young people, because of the reference to Chinese young people and parents. This shows a tendency for DDY to generalize.

However, it seems that the idea of independence features prominently in DYY's perception of Americans. This idea of Americans being independent could either be part of DYY's existing

knowledge and perception of Americans, or this idea could have developed through the process of comparing American film characters with Chinese young people. Alternatively, this idea could also be the combination DYY's pre-existing perception of Americans, and the 'comparison sense-making activity' he undertook while watching the film clip. This issue, which is related with 'effect', will further addressed in the next chapter, which will deal with discernible effects of films viewing on Chinese college students' understanding of and attitudes to other peoples and cultures.

Looking at above example, DYY started by comparing the character Ben, an American young man, with Chinese people. Then, he compared American young people in general with Chinese young people. This indicates that DYY's comparison activity fall into two stages, first comparing a character with Chinese people, and then comparing American young people with Chinese young people. As a result, DYY identified differences between the character and Chinese people, and differences between American young people and Chinese young people.

Let's look at another example which also falls into this category.

After viewing the clip *London bench day* from the film *Love Actually* (2003), LAQ explained what she thought of the father's approach to his son. She showed positive attitude towards the father character. Then she said:

(Q.6.2.3.4)

LAQ: 我觉得，外国就是，父母和小孩的关系比中国父母和小孩的关系要平等一些。在我们国家就少。

Interviewer: 我们国家是怎样?

LAQ: 中国就是我是老子你是儿子你就得听我的。不听我的你就挨打，但是外国我觉得就不是这样子的。感觉上应该不是这样子的。

Interviewer: 为什么呢?

LAQ: 我就觉得东方和西方的差异问题吧。中国还是传统一些，比西方肯定，各个方面都传统一些，就是中国自古以来的那种挂念，那种家庭礼教的观念。从古到今就是这样子的，我是长辈，你是小辈，说话就得和我很尊敬，就得很尊重我。要是有什么言语上的冒犯啊什么的，就肯定就会受责备或者惩罚。整个就觉得西方文化比中国开放很多，各个方面都很开放很多。

English translation:

LAQ: I think, in foreign countries, the relationship between parents and children is more equal compared to Chinese parents-and-children relationship. It's rare in our country.

Interviewer: What about our country?

LAQ: In China, I am father, you are son, you have to obey me. If you don't obey, I will beat you. But in foreign countries, I think it's not like this. It feels that it shouldn't be like this.

Interviewer: Why?

LAQ: I think this is the difference between the East and the West. China is more conservative, definitely, compares to the west, more conservative in every aspect. It's kind of concept ever since ancient China, the concept of family and code of ethics. It's always the same from ancient times to the present, I am the senior member of

the family and you are the younger member of the family, you need to respect me. If there's any verbal offence, it will certainly be blamed and punished. Overall, I feel that western culture is a lot more open than China, a lot more open in every aspect.

What LAQ did was to compare two groups of people, foreign parents and children and Chinese parents and children. In particular, LAQ compared the relationship between foreign parents and their children with the relationship between Chinese parents and their children. In doing so, LAQ expressed her ideas of what the relationship is like in both groups. In addition LAQ gave reasons behind the differences between these two groups by exploring and giving examples such as the concept of family and the family code of ethics in the Chinese culture.

Considering DYY and LAQ, in their sense-making process they both compared people represented by the character with Chinese people. As a result of their comparison, they both identified differences between the two groups and enhanced their understanding and view of both the group of people represented by characters and the Chinese people.

- **Concepts of 'foreign' and 'western'**

It is worth mentioning the word 'foreign' that LAQ used in the process of comparison. In a previous part of the interview extract, when LAQ was talking about the characters Sam and the father, she was aware that both of the characters were British. However, LAQ went a step further and made a comparison between Chinese people and foreign people, rather than people from any particular country. From the reasons that LAQ gave to explain the differences between foreign people and Chinese people, such as cultural differences between the East and the West, there is a strong link between the concept of 'foreign' and the concept of the 'western'. The concepts of 'foreign' and 'western', to some extent, are identical or interchangeable for LAQ.

More similar cases were found from the qualitative data. For example, DC talked about an American film that she watched before, *Mean Girls*²².

(Q.6.2.3.5)

DC: 我记得还有一个镜头是他们高中老师脱衣服，她想脱一件，结果把两件给脱了，这个镜头我想，也许他们那边师生关系不像我们这边那么严肃，他们那边好像更多的是朋友，互相玩伴的关系，多与传道守业解惑的关系。中国肯定会有师道尊严，中国 5000 年的文化，而且儒家的文化就是尊师重教，这种已经是根深蒂固了，不可能改变。

English translation:

DC: I remember there was also a scene, in which, their high school teacher took off her tops. She wanted to take off one; as a result, she took off both of them. This scene made me wonder, probably, teacher and students relationship over their side, might not be as this serious as our side. On their side, it seems more like friends,

²² Mean Girls: it is an American film released in 2004. The film is about a girl's (used to be homeschooled) complex love and hate relationship with three other girls in from the same high school.

playmates for each other. In China, it's definitely the absolutely authority of the teachers. Five-thousand years of history in China, plus, the Confucius culture is about 'honour the teacher and respect his teaching'. This is deep-rooted and impossible to be changed.

Here, the two groups of people DC compared were teachers and students in China and teachers and students 'on their side'. Based on the fact that the characters in the film were Americans, it could be speculated that the teachers and students 'on their side' that DC was referring to were from the U.S.A.

However, this is not necessarily the case. It seems that many CCSs do not always distinguish between countries in the west. Based on findings from the qualitative data, many CCSs use words such as *foreign* (外国), *western* (西方), *on their side* (他们那边), *they* (他们), as catch-all phrases which blur the boundaries between individual countries, in particular, the U.K. and the U.S.A.

For example, PP used 'foreign countries' (国外) during her comparison activity. After viewing A *father-son chat*²³, PP said:

(Q.6.2.3.6)

PP: 太逗了。我觉得这种父亲在中国肯定看不见的这种。我们学校初二的时候就组织去开发区看过性教育展，都是图片什么的，... 但是老师从来不会谈这个，只要你自己去看，你看就得了，回来车上也不要说，谁也不许说，就那样，就是比较闭会的那种。但是他们的这个就是... 这就是一项知识，没有什么可以闭会的，而且父母也是希望你掌握... 因为掌握这个知识，你有了这个知识总比没有好，你自己不会受到伤害。就是这些... 像中国好多孩子你自己没有这些知识，然后就去别的渠道去获取。反正就是不正常，不好的那种。还是这样比较好。而且我觉得，在国外他们那个孩子和家长之间的交流特别好，就是很像朋友那种，什么亲爱的，宝贝我爱你啊什么的，这些说的很多，我觉得在中国很少见。就比较不善于表达自己感情的那种。

English translation:

PP: This is so funny. I think this type of dad definitely does not exist in China. In the second year of secondary school, our school organized a trip to a Sex Education Exhibition, all pictures etc. ... but teacher never talked about it, just let yourself to watch, just watch, and not supposed to talk about it in the bus on the way back, no one was supposed to talk about it. It's fairly kind of like, taboo. But for them, this is ... this is a kind of knowledge, there isn't anything forbidden, plus, parents also want you to master (the knowledge) ... because it's always better to know the knowledge than not knowing, you will not get hurt. Things like ... like many Chinese young people, don't have this knowledge, and obtain from other resources. Anyway, it's not normal, not good. This way is better. Plus, I think, in foreign countries, communication between Children and parents is particularly good, very much like friends, they say a lot, like, 'dear', 'Baby, I love you' etc. I think, this rarely happens in China. Relatively not very good at expressing own feelings.

²³ A father-son chat: a clip chosen from the film *American Pie* (1999). In the clip, Jim, who has a pack with his friends to lose their virginity by the end of high school, is checking his newly purchased condoms. He father knocked on the door and came in with a bag of adult magazine. His father tries to help his son to learn more about female body.

There is a lot of comparison going on. First, based on PP's comments that the type of dad like Jim's father does not exist in China, it can be speculated that this idea of PP's was reached from a comparison between the character, Jim's father, and Chinese fathers in general. Hence, the fact that PP believed no father like Jim's father exists in China was due to the sharp contrast between the character and the image of Chinese father in PP's mind.

Also, PP's personal experience at school in terms of receiving sex education from teachers played an essential role in terms of facilitating her views and understanding of Chinese people's view on sex education and how to approach it for young people. The word 'taboo' PP used indicates PP's view on teachers' and students' attitude toward sex education at school.

In addition, PP compared communication between parents and children in foreign countries with communication between parents and children in China. The phrase indicates that the particular group of people, parents and children in foreign countries, is not limited to people in the U.S.A. To PP the characters Jim and his dad represent a group of people which includes not only Americans, but also people from other countries.

Also, by saying "this way is better" (这样比较好) indicates that PP could prefer both the fictional parents' approach as well as parents in foreign countries approach to their children in terms of sex education. What is more, PP's comments on communication between parents and children in foreign countries indicate her positive attitude towards them. Meanwhile, PP's comments also indicate that PP had, to some extent, a negative attitude towards Chinese people's approach towards sex education and communication between parents and children.

The previous examples show that sometimes CCSs compare group of people represented by characters with group of Chinese people who are equivalent with the characters. As a result, CCSs identifying differences between two groups may form or reinforce either positive or negative attitudes to both groups of people. Information gained from viewing the films and TV series, existing knowledge and personal experience all play essential roles in identifying differences during the sense-making process.

The text extract below is from a four-people group interview. After viewing the clip, *Step off* from the film *School of Rock* (2003), four CCSs had a discussion:

(Q.6.2.3.7)

S1: 朋友盛过老师。在中国，老师就是老师。不过课堂上老师就是老师，下了课你可以和他成为朋友，但是一般在课堂上他们都不会，就是备好课给你将，提问题，有的时候还是可以说自己的见解，但是很多时候都是说一些已经成型的理论什么的。

S4: 我感觉中国的那种师生关系可能就是在当时要更严肃一些，外国更活泼，更互动。但是我觉得从长期看，因为可能受多年从前的思想影响，中国那种门第观念很浓重，一说谁谁是我的老师，就像利益集团一样，但是在外国有没有这种东西我不清楚。可能在外国可能如果上的学历比较高的话，像你的导师是谁啊，教授是谁啊，可以以为自豪的，但是我觉得在中国好像这种观念，从小学中学就有这种观念了。你看往往就是毕业多少年后再相距那种，对老师的那种感情就像自己的长官一样，就是门第观念特别，一说出自哪个师们，就跟武侠小说一样。

S1: 就是觉得美国那边不一样吧。挺开放的，不像我们那么严肃吧。

S3: 其实他们那种教学方式挺好的，相对比来说，我们这边就是比较压抑吧。

S2: 没错。而且英美那边的老师就是特别放得开我觉得。不像我们这边，特别严肃。

English translation:

S1: Being a friend more than being a teacher. In China, teacher is teacher. In the class, teacher is teacher. You can be friends with him after class, but, normally, not in the class. (Chinese teachers) Prepare lesson and teach you, ask questions, sometimes (we) can express our own opinion, but, most of the time, (teacher) will explain existing theories etc.

S4: I think the Chinese-teacher-and-students-relationship is probably more serious, whilst, foreign (-teacher-and-students-relationship) is more lively and interactive. But I think, looking from long-term perspective, it's probably has long been influenced by traditional ideology, the kind of Chinese concept of status is very strong, once said someone is my teacher, it's like a benefit group. But I'm not sure whether things are like this or not in foreign countries. Probably, in foreign countries, maybe, when pursuing a higher degree, for example, who is your supervisor, who is your professor, people whom you can be proud of. But I think, in China, this concept exists from primary school. [...]

S1: (I) feel that the (teachers on) U.S.A. side is not the same as over here. Fairly open, not as serious as we are.

S3: Yah. Actually, their teaching approach is pretty good, comparatively, we are relatively constrained.

S2: Indeed. Plus, teachers over the U.K. and U.S.A. sides are fairly relaxed, not like our side, very serious.

There is a lot comparison going on. First of all, S1 compared the character, teacher Dewy, with Chinese teachers. Following S1, S4 compared foreign teachers with Chinese teachers. In explaining the reasons for the differences between these two groups, S4 drew on his knowledge on Chinese culture, specifically the concept of status. Although he tried to imagine the relationship between teachers and students in foreign countries, he did not reach any definite conclusion.

S1 noticed the differences between American teachers and Chinese teachers. S3 pointed out more differences by further comparing these two groups. From S3's comments, there is a subtle hint that S3 might have a positive attitude towards American teachers. It can be speculated that S3 has a slightly negative attitude towards Chinese teachers. S2 also made a comparison. However, it seems that for S2, teachers from the U.K. and the U.S.A. are in a single group, as she compared them as a group with Chinese teachers. A hint of positive attitude towards British and

American teachers and negative attitude toward Chinese teachers can be detected in S2's statements.

First of all, the above example shows that, having viewed the films, talking with peers facilitates CCSs making sense of what they watch. This demonstrates one of the factors which affect CCSs making sense of films, peer influence.

Second, although CCSs are aware of the fact the U.S.A. and U.K. are two different countries, most of the time they group these two countries together in process of comparison.

Third, comparing two groups of people often leads to certain understandings and views about both groups. However, this is not always the case. Some CCSs reach an overall understanding of both foreign people and Chinese people by identifying differences. However, for some CCSs reach an understanding of Chinese people, whilst their understanding of foreign people is speculation, with nothing being certain.

Last but not least, identifying differences as a result of comparison sometimes leads to or reinforces positive or negative attitude towards to foreign people and Chinese people.

With regard to attitudes, let's look at another example. I showed the clip, *London bench day* from the film *Love Actually* (2003), to two CCSs, JT and TXH. After viewing the clip, they explained to me what happened in the clip and then continued:

(Q.6.2.3.8)

JT:他们和中国处理不一样。他们的小孩子不用学那么多的东西，以后一样可以成长起来，到最后他会明白很多事情，慢慢自己会成为，就是家长希望的那个样子。其实另外一种方式就是管，和孩子沟通啊，好像其实也能达到一种很好的效果，就是跟中国国家完全不一样的方式的话，不是说是中国好还是英国好，因为国情不一样，就是你在里面体会到的是一种不同，而不是好坏。两种方式都会有他的问题吧。

Interviewer: 方式如何不同?

JT: 他们就是一种相对比较理智的一种态度吧。然后中国可能比较感情用事一点，就觉得自己的孩子，为什么不能管？我就不准他这个样子，我是他妈妈，我生他，为什么我连管他的权利有没有？就比较感情用事。他们就会比较理智，就不想自己是不是父亲还是母亲，然后去降低自己的告诉，做朋友，去看待这种问题。

English translation:

JT: [...] they approach to things differently from Chinese. Their children do not need to learn so many things and they can still grow up, eventually they will understand many things, gradually they will grow into people ... as their parents expected. Actually, another approach is to control. To communicate with children, it seems can also reach a very good result. This approach is completely different from China. (I'm) not saying China is good or U.K. is good, because conditions of two countries are different. It's difference that I realized not good or bad. Two approaches both have problems, I guess.

Interviewer: What difference?

J: Their attitude is relatively sensible, while Chinese are rather under the sway of emotions. (Chinese parents) think “why can’t I control my own child?” I do not allow her (behave) like this. I am her mum, I gave birth to her, why don’t I even have the right to control my child?! Rather emotional. They are more sensible, (they) don’t consider themselves whether they are father or mother, they would be friends with their children, to deal with the issue.

JT compared British parents’ approach to children with Chinese parents’ approach to children. However, having noticed the differences between two groups, JT did not state any preference for either British or Chinese parents’ approaches. Instead of showing any positive or negative attitudes towards either of the group after comparison like some of the CCSs did, JT emphasized the differences between two groups.

Compared to the other CCSs, something very special about JT is that she was able to distance herself and look at British and Chinese parents with an objective attitude, taking context into consideration.

6.2.4 Summary

In addition to ‘comprehending the plot’, another main category of sense-making activities emerged from the empirical data is ‘compare: identifying differences’. When Chinese college students (CCSs) make sense of films and TV series produced in the U.K. and the U.S.A., they may identify differences on three different levels.

The first level is comparing fictional character(s) with the student herself/himself or Chinese individuals who play significant roles in their lives, such as parents and teachers. Also, some CCSs compare characters with individuals whom they know, such as a relative of a course-mate. The second level is comparing fictional character(s) with equivalent groups of Chinese people, rather than individuals. Findings indicate that CCSs do not compare fictional characters with just any individual or group of Chinese people; rather they compare characters with individuals or groups of Chinese people who share some commonalities with those characters, such as age, gender and family or society position.

The third level is comparing groups of people represented by fictional character(s) with Chinese people. The findings from qualitative data suggest that CCSs do not tend to distinguish between British and American. Instead, they tend to mix them together. Although CCSs are aware of the fact that the U.K. and the U.S.A. are two different countries, it seems that for many CCSs British and American belong to the same group. By using catch-all phrases such as ‘foreign’, ‘over their side’ and ‘western’, it seems that the boundaries among countries in the west (specifically the U.K. and the U.S.A.) are blurred to them, not on a geographical level, but on a cultural level.

In addition to identifying three levels at which differences are compared, three important variables which affect identifying these differences have also been identified. They are: interpretation or understanding of the clip (or film); existing relevant knowledge; and life experience.

- **Interpretation**

Here, interpretation includes plot comprehension and interpretation of the characters. As mentioned, plot comprehension refers to understanding of what happened in the clip or full-length film. 'Interpretation of the characters' refers to viewers' personal interpretation of the characters' actions, motivations and personalities, or, in other words, the student's view on what kind of person a character is and why a character does certain things etc.

- **Knowledge**

This refers to viewers' existing relevant knowledge of *themselves* and *foreign people and culture*. This knowledge is text-relevant, which means the relevant knowledge depends on the characters and context provided in the clip (or film), such as nationality, ethnicity, age, occupation etc.

- **Experience**

This refers to viewers' having personal experiences which are similar to the experiences of the the character(s) in the clip. For example, communication between parents and child in everyday circumstances happens both to fictional characters and to viewers themselves.

With regard to the core research question, how Chinese college students make sense of films and TV series produced in the U.K. and the U.S.A., two of the main categories emerging from empirical data, 'comprehending plot' and 'compare: identifying differences' have been illustrated in above sections.

The third category of sense-making activities, 'compare: identifying similarities', will be the focus of the following section.

6.3 Compare: Identifying Similarities

"I was, and still am, surprised and fascinated by the fact that those Chinese college students manage to see so much in common between themselves and those fictional characters in foreign films." (My memo on the 27th Aug 2009)

6.3.1 Compare: Identifying Similarities: Fictional Character(s) & Self/Significant Individual

(Q.6.3.1.1)

PP: 这个我觉得跟中国差不多吧。比如说,我们...就是说跟男朋友约会之前, (我)肯定也想把自己打扮的漂亮一点, 然后就问宿舍同学我穿这个怎么样? 我应该

怎么办，应该怎么办。就是大家都会讨论这个东西。我觉得这个应该挺像的。

English translation:

PP: I think this is more or less the same with China. For example, we...before going out with a boyfriend, (I) definitely want to dress up prettier, and then ask my course-mates in the flat “how do I look wearing this?” What should I do and so on.

Everybody talks about this. I think this ought to be very similar.

Having watched a clip from the film *Bridget Jones's Diary*²⁴, *Prepare for launch*²⁵, PP, who had not seen the film before, briefly told me her understanding of the plot. Then, by comparing the character Bridget with herself, PP recognized similarities between herself and the character. First, according to PP's personal experience, like Bridget, she also dresses herself up before a date with a boyfriend. Second, like Bridget, PP also talks to her friends to ask for advice before going out with a guy she likes. In addition, the word *everybody* PP used in the underlined sentence indicates that PP believed that she was not the only Chinese girl who does this; other Chinese girls do this too. Although PP did not give details of whom she meant by *everybody*, it can be speculated from her comments who *everybody* refers to: PP's friends in or outside of the college, course-mates from the flat, and most probably, any other Chinese girls in the similar age group in China.

WZT, another female Chinese college student, also watched the same clip for the first time. While WZT was explaining her understanding of the clip, she said:

(Q.6.3.1.2)

WZT: 然后再一个，她这点和我挺像的。

interviewer: 怎么了？

WZT: 就是说她就是要和男人约会，要问自己的闺蜜。这个我觉得是...基本上我们这个年龄的女生都会的。

English translation:

WZT: And one more thing, she is pretty similar to me in this aspect.

Interviewer: How?

WZT: (I mean) She is going to go out with a man, and wants to ask her close friends. This I feel that ... basically all girls in our age would do (things like this).

WZT pointed out one thing she had in common with the character, Bridget, is that she also seeks for advice from close friends before going out with a boyfriend. In addition, according to WZT, she is not the only Chinese girl who shares this similarity with the character: she believed that *all* Chinese girls in her age would do so.

²⁴ *Bridget Jones's Diary* (2001): this British film is about Bridget, an average thirty-something British woman who is “struggling against her age, her weight, her job, her lack of a man, and her many imperfections. As a New Year's Resolution, Bridget decides to take control of her life, starting by keeping a diary in which she will always tell the complete truth”(IMDB, 2009) about herself. The film tells of the love affairs between Bridget and two British men, Daniel, who appears to be a playboy, and Darcy, whom Bridget finally falls in love with.

²⁵ *Prepare for launch*: a clip chosen from the British film *Bridget Jones's Diary* (2001). In the clip, Bridget needs to prepare for an important social occasion at her work, at which Bridget plans to entice Daniel, the man she fancies and hopes to date. Bridget turns to her close friends, Jude, Sharon and Tom, to ask for help. The clip also includes Bridget's preparation in her bedroom, such as choosing which underwear to wear, practicing her introductory speech, etc.

First of all, the above two examples show that PP and WZT both responded to the main character, Bridget. In addition, both of them compared themselves with the character and identified similarities in terms of things that they do before a date.

Second, they identified similarities between the character and not only themselves, but also other Chinese girls. Comments from PP and WZT, such as “everyone talks about this” and “all girls in our age would do”, indicate that the Chinese girls PP and WZT were referring to include not just *any* Chinese girls but the Chinese girls who belong to the same age group in the society. A tendency to generalize is evident.

Finally, WZT’s and PP’s interpretation of the character, personal experience, and knowledge of themselves and other Chinese girls in a similar age group, all played an important role in the process of identifying similarities.

There was a male student, XY, who had watched the same film before. However, he could not recall much when he was asked to describe the film. Two reasons might have caused this. One, XY’s memory of the film was not fresh, due to the fact that he watched it a year ago. Two, a film which is mainly about a thirty-something-single-woman’s love story might not make a deep impression on male CCSs, as XY himself explained: “I don’t have a deep impression on this film; probably it’s because of the fact that I am a man.” However, for female CCSs, such as WZT and PP, they both appeared to respond to the female character by identifying similarities with her. This is because they both are female and both share the similar experiences with Bridget, making it easier for them to relate to the character.

Now, let’s look at another male CCS’s response to the same clip. PWB watched the clip for the first time. After he told me what happened in the clip, I asked:

(Q.6.3.1.3)

Interviewer: 那有让你对英国那边的女生约会有了解吗?

PWB: 这个我到没怎么在意。女孩子出去都需要准备啊。而且我对这个也不了解。我怎么知道她们要怎么准备。

Interviewer: 会不会觉得这个英国女孩和中国女孩有什么不一样?

PWB: 没什么不一样啊。中国人不会说,像,一群人在一起讨论。应该就自己打扮了。

English translation:

Interviewer: Does this tell you how girls in Britain prepare before going out for a date?

PWB: Actually I didn’t pay attention (to this). All girls need to prepare before going out. Plus, I don’t know about this. How do I know how they prepare?

Interviewer: Do you feel there are any difference between this British woman and Chinese girls?

PWB: There is nothing different. Chinese people would not, like, a group of people gather together and discuss. (They) probably would dress up on their own.

Overall, PWB did not seem to respond to the character Bridget as strongly as WZT and PP did, let alone identifying similarity with the character. PWB did not seem to have sufficient amount of relevant knowledge and experience about what girls do before going out with boyfriends to make any relevant comparisons. Finally, although PWB stated that there was no difference between Bridget and Chinese girls, his comments actually suggest the opposite.

Looking at PWB's comments more closely, especially the last underlined sentence, perhaps he answered the questions before thinking things through. He clearly had not made any comparisons while watching the clip. At the beginning, he explained that he did not really know what girls do before the date. After further prompting, he first said that there was nothing different between the character and Chinese girls. Then he pointed out that Chinese girls actually would not consult their friends, which is opposite to what Bridget does in the clip. This final point is interesting, because he already admitted that he knew almost nothing about Chinese girls on this matter. Where did he get this idea then? Actually he used the words *Chinese people*, instead of *Chinese girls*, suggesting that his final statement was his assumption, guess or speculation, based on his general knowledge on Chinese people, as well as his experience as a male.

Looking at above examples, *gender* seems to be one of the main factors affecting CCSs identifying similarities with a character. For example, WZT and PP recognized things in common with the character Bridget, whilst PWB did not. It can be seen that some part of the CCSs' framework of knowledge, life experience and interests is gender specific, and this affects their response to, involvement with and interpretation of the characters.

Now, let's look at another exemplary interview extract from data. I showed the clip, *A father-son chat* from the film *American Pie* (1999), to XY, the male CCS mentioned above. He had watched the film before. Although he could not remember the details of the film, he still remembered the main plot, which is three final-year high school boys trying to lose their virginity before going to the college. After viewing the clip, he said:

(Q.6.3.1.4)

XY: 像他们父子之间聊天吧, 觉得他们也, 恩...说明他们之前也没聊过这方面的话题。但是实际上, 就是他老爸可能觉得儿子没了解的那么多。但是实际上他都了解。就是...我们其实都这样, 虽然...关于性这方面的知识, 基本上都是自己, 自己都忘了从什么地方东拼西凑, 慢慢就了解了。其实并不是什么性教育课啊, 爸妈也没讲过。恩...但是他爸爸把杂志带给他看, 就是也挺有美国特色的。中国的话, 都比较含蓄嘛, 但是他的话, 就恩...他老爸也觉得比较尴尬, 但是还是把它拿出来给他看。他可能就是觉得自己以前也是经历过来的吧。

English translation:

XY: For example the chat between that dad and son, (I) think that they also, erm ... this shows they have not talked about topics in this aspect before. But actually, the dad probably thinks that (his) son does not know that much. But actually he knows it

all. It's ... we actually all (do) the same, although ... about the knowledge on sex, basically it's all self, even (I myself do not remember where (I) gathered all the bits of the knowledge from places, gradually understanding. Actually it's not from sex education classes; dad and mom didn't talk about this. Erm ... but his father brought magazines for him, this has American characteristics. Chinese people, all relatively reserved, but him, erm ... his dad of course feels embarrassed, but he still brought him the magazine. He probably himself has received similar education before.

In addition to interpreting the characters in the clip, XY identified similarity with the character, Jim. As indicated by the underlined sentences, according to XY, his experience of gaining knowledge about and reaching an understanding of sex is similar to Jim. However, the film does not actually tell us how Jim learns about sex. XY decided that Jim has gained this knowledge from sources other than his parents, including sex education classes. This means, how Jim learns about sex is part of XY's interpretation on this character. XY identified similarity between himself and Jim based on his interpretation of Jim as well as his own experience.

In addition, the fact that XY said "we actually all do the same" (我们其实都这样) indicates that XY not only identified the similarity between himself and Jim but also, he identified similarity between other Chinese people and Jim. XY's comments do not indicate which group of Chinese he refers to as 'we'. He probably intended to refer to the Chinese guys who belong to the same social group as he does.

The rest of the interview extract after the underlined sentences provides an additional example of identifying difference. XY's comments on Jim's dad indicate that XY's understanding of Jim's dad fits his existing impression of Americans. In other words, to XY, the characteristics of Jim's dad are recognizably American. XY compares Jim's dad with Chinese parents, most probably Chinese dads. As a result, XY identifies the differences between Jim's dad and Chinese dads.

The exemplary interview extract above demonstrates that Chinese college students, through comparison, sometimes identify similarities between themselves and the fictional character(s). In addition, as XY's interview extract indicates, sometimes identification of similarities and differences go hand in hand.

I showed the clip, *Dining saloon*²⁶ from the film *Titanic* (1997), to WZT. Like all other CCSs, WZT had watched the film before. After viewing the clip, I asked WZT about the characters in the clip.

(Q.6.3.1.5)

Interviewer: 你刚才说了很多上流社会的人，那你觉得那些上层社会的人对 Jack 的态度如何？

²⁶ Dining Saloon: a clip chosen from the film *Titanic* (1997). In the clip, Jack, a freelance artist, who saved Rose, an upper-class lady in her twenty's, was invited to dine with her and other upper-class friends in the first class lounge in the ship called *Titanic*.

WZT: 有钱人嘛，就会做一点，我觉得也比较正常，你看现在的社会，我们大学生之间都有，就是家里条件好一点的，和条件不好的。像我们上学期的时候，我们隔壁宿舍的，有一个北京的，还有一个海南的，北京的那个比较有钱，然后海南的那个来回飞来飞去的嘛，然后他们是两个农村的，反正她们之间两极分化挺严重的。就是我觉得，在一个宿舍里，大家最好，我们宿舍也有，就是北京的那个很有钱，然后也有特别就是，昨天那个女孩子，他们家就是比较没钱的。我们剩下的就是比较中等阶级。

English translation:

Interviewer: You talked a lot about upper-class people just now, what do you think of their attitudes towards Jack?

WZT: Rich people, usually, are a bit arrogant, I think (this) is normal. Look at the society nowadays, it even exists between us, the college students, (students) from families with better conditions, and (students) from (families with) bad conditions.

For example, in last term, the dorm next to ours, there's a (student from) Beijing, and one (student from) Hainan, the one from Beijing is quite rich, and the one from Hainan fly between home and the Uni, and there're two others from rural area, anyway, the polarization is quite serious. I think, in a dorm, it's best that everyone... It is the same in our dorm, the one from Beijing is quite rich, and especially the girl from yesterday (the girl that was interviewed by me the day before), her family is relatively poor. The rest of us are relatively middle-class.

WZT identified the similarities between the characters, the arrogant rich passengers and Jack (who does not have money), with her experience as a college student in Beijing. More specifically, according to WZT, just as there is a gap between the rich and the poor passengers in the film, there is also a division among CCSs, including those in her own dorm, due to the difference of wealth among CCSs. After telling me about the division among students in her dorm and the dorm next to hers, she then continued:

(Q.6.3.1.6)

WZT: 我们宿舍北京的那个特有钱，但是人特别好。剩下我们几个都是中等阶级的了。像她们宿舍两个没钱的，两个有钱的，两极分化特别严重。天啊，闹的帮派什么的。所以我觉得很正常。比如说我在火车上一个民工，背着大包的那种，我就会瞪他一眼，那种鄙视我不会说出来，但是我有时候会有那种很厌恶的感觉。当然和他比我属于比较有钱的那种了，但是我上面也有比我有钱的，但是我就有资格，也不是说有资格，我是说我鄙视那种人，也不能说是鄙视吧，就是有的时候就是这样，我觉得是很正常的一种行为，我上面的人也可以这么鄙视我。我觉得是很正常的。[...]

English translation:

WZT: The one from Beijing in our dorm is very rich, but a very nice person. The rest of us are all middle-class. Like, in their dorm, two poor (students) and two rich (students), the polarization is very serious. Oh my god, gangs and conflicts etc. So, I think this is very normal. For example, if I encountered a 'migrant worker', the kind with big bag, I would give him a contemptuous look. I would not tell the feeling of contempt, but sometimes I have discussed this kind of feeling. Of course, comparing to him, I count as rich, but there are people who are richer than me, but I am qualified, not qualified, I mean, I despise that type of people, well, not despise, well, sometimes it's like this. I think this is a normal behaviour. People above me can also despise me. This is very normal.

It seems that WZT's point of view on the matter of the rich and the poor is heavily influenced by her own belief and experience, and more specifically what has happened around her. Not only is there a wealth-relevant-division in her dorm and the one next to hers, but there are also problems among CCSs in the dorm next to hers caused by the division.

The above text extracts show that WZT identified similarities between the characters and herself and the CCSs around her, as well as people who fall into the rich and poor groups in the society. Based on WZT's comments, she looked down on migrant workers in the train, while she also was aware that she may well be looked down upon by those who were richer than her. The fact that she accepts this social hierarchy is interesting.

I showed another clip, *Director*²⁷, to the same student, WZT. She had not watched the film before. After viewing, while she was telling me her understanding of the character, she specifically pointed out one issue in the clip which confused her:

(Q.6.3.1.7)

WZT: [...] 所以我很奇怪他怎么能，当一个导演。

Interviewer: 哦...

WZT: 我觉得真正来说，我觉得，白人应该是当个导演，因为在各种领域里我觉得白人应该是头儿。黑人，要么，你根本就连这个领域进不来，要么你近来了只能做个副手那样的。像我们家，就是，这个就能和我们家联系了，我们家是个自治州，自治州不就是应该民族自治嘛。我们那边是藏族自治州，那就是藏族人自治了，象我们这种，象我是土族的嘛，然后还有那种汉族的，然后进去之后就只能当个副手。从来没说，汉族人进去了，当了个主任，藏族人进去了反而当了个副主任，这个绝对是绝对不可能的。所以我看这个我就觉得特别莫名其妙，我就觉得黑人居然能当个导演，因为我觉得，正常的话，要么黑人就是这个剧组都进不来，要么就算他进来了，他也是个副手。结果他还是个导演。真奇怪。

English translation:

WZT: [...] So, I'm very confused that how come he (Cameron) can be, a director.

Interviewer: Uh huh...

WZT: I think, really, I think the white people should be directors, I think the white are leaders in all kinds of fields. The black, either, you basically cannot enter this field at all, or, even if you enter (the field) you can only be a deputy. Like in my family, like, this can be related with my family, we are in the autonomous prefecture; autonomous prefecture is an ethnic group autonomous prefecture. Ours is the Tibetan Autonomous Prefecture, which means, Tibetan self-governing, like, for example, I am Tu, and there are (people who are) Han, then, (Han) can only be a deputy when enter (i.e. organization). It's never, like, Han people enter and become the director, and Tibetan enter and become a deputy instead. This is absolutely impossible. Therefore, when I saw this, I felt puzzled, the black can actually be a director because I think, normally, either the black cannot even enter the crew or,

²⁷ Director: the clip chosen from the American film *Crash* (2004). In the clip, a black director Cameron shoots scene with the rest of the crew. After the shooting, Cameron is happy with it but another member of the crew who is a white guy suggests the need for another take because the black actor does not sound 'black'. Although Cameron does not see need for another take, he then decides to do it again.

even if he takes the part, he can at the most be a deputy. Unexpectedly, he is a director. Really strange.

As the first underlined sentence shows, WZT felt puzzled about the fact that the director in the clip is black. This is partly due to the mismatch between her existing stereotypical knowledge and view of white and black people and what happens in the clip. WZT is from Qing Hai Province²⁸ which is in one of the Tibetan Autonomous Prefectures²⁹ in the west of China, where the majority of the population is Tibetan. The rest of the population is formed by some other ethnic groups, such as Tu³⁰, Han, etc. Although Han has the biggest population in China, it is the minority in autonomous prefectures. According to WZT's experience, the Tibetan is always superior to Han in her hometown. Although WZT did not provide any details about her own ethnic group, Tu, it can be speculated that Tu's status might be similar to Han³¹. It seems that WZT also assumes a similar hierarchical relationship exists between white and black people. WZT response to the clip therefore is culturally specific. One can only speculate that Obama's election to U.S.A. president may have changed her view since the time of the interview, and that the clip would not generate this level of confusion if she viewed it now.

A female CCS who had watched the film *Gone with the Wind* (1939)³² told me that the film was her all-time favourite. She explained:

(Q.6.3.1.8)

SY: 我最喜欢的电影就是说...到现在为止...我最喜欢的电影还是乱世佳人啊。

Interviewer: 为什么?

SY: 就是因为,我也不知道我看的时候是什么心情,不过就是说看的时候触动最大的就是那一次。不过现在让我回忆一下情节我也想不太起来了。

Interviewer: 为什么会对你触动这么大?哪一方面?

SY: 不知道,可能说...当时的话,就是Scarlett的境地和和我那个情境也比较相似吧,因为那个时候我也出现感情上的问题(不好意思),当时挺痛苦的...哈哈(脸红)

Interviewer: 哦,我明白了!

SY: 不好意思说...(笑)

Interviewer: 没关系。(微笑)

²⁸ Qing Hai Province is located in the west of China, is one of the 22 provinces in China. A province is a translation of Sheng (省), which is the first level of administrative division in China.

²⁹ An autonomous prefecture is a second-level political-administrative division, between province and county levels, granted independence in internal affairs by the Chinese Constitution. With representation from the nationalities of the region exercising autonomy, the governing bodies of autonomous prefectures exercise substantial freedom in the formation of educational, scientific and cultural policy, operating with state financial, material and technical assistance (2004, Constitution of People's Republic of China). In Qing Hai Province, there are eight Autonomous Prefectures, among which five of them are Tibetan Autonomous Prefectures, divided by region. They are Haibei, Haidong, Hainan, Huangnan, Yushu, and Golog, Tibetan Autonomous Prefectures.

³⁰ Tu is one of the official 56 ethnic groups in China.

³¹ Han is one of the official 56 ethnic groups in China. Han has the biggest population compares to the rest of the ethnic groups

³² *Gone with the Wind* (1939): One of the main storylines in this American film is the love affairs between the main female character, Scarlet, and two other men: Ashley, the man whom she has wanted for so long and who finally marries another woman, and Rhett, the man whom she truly loved but finally loses.

English translation:

SYY: My favourite film is ... until now ... my favourite film is still *Gone with the Wind*.

Interviewer: Why?

SYY: Because, I don't know what mood I had when I watched it, but, that was the time when my feelings were most greatly stirred. But I cannot remember the details when I recall the plot now.

Interviewer: Why did it stir your feelings this greatly? Which aspect?

SYY: I don't know, at that time, Scarlett's situation was quite similar to my situation because, at that time, I also encountered problems concerned with love and emotions (appeared to be shy), I felt very painful at that time, hahaha (face was blushing).

Interviewer: Uh huh, I see!

SYY: I'm too embarrassed to tell ... (laugh)

Interviewer: That's all right (smile).

Although SYY did not give details of the situation which she indicated to be similar to Scarlet's, based on SYY's comments, what she was experiencing at that time seems to be similar to Scarlet's experience with either Ashley or Rhett or both. The similarity between SYY's experiences and those of the character seems to have struck a sympathetic chord.

This exemplary interview extract shows that the identification of similarity between the character and the CCS herself plays an important role in the viewing experience and the CCS's involvement in the film. SYY's experience shows that even though it was a long time ago when she viewed the film, and even though she could not remember the details of the plot, she still remembered was how greatly her emotions were stirred by the fact that she shared similar experiences with the character portrayed in the film.

Let's look at another similar example. When talking about films that gave deep impression, XY told me that *American Beauty*³³ was his favourite film and gave him a deep impression. I asked why:

(Q.6.3.1.9)

Interviewer: 为什么会这么深刻呢?

XY: 就是觉得和自己有多相象的地方.平时有很多地方,和他想的就是有,就是觉得有很多相同点。

[...]

Interviewer: 我觉得你也就 19 岁,你多大?

XY: 20 岁。

Interviewer: 你才 20 岁,那你觉得会从他身上看到自己的影子呢?我觉得这个很奇怪哦。说说?

XY: 比如说他的颓废吧。其实我也有过那种感觉。因为,其实初中的时候,也算是非常,就是成绩很好的那种,然后什么地方都会照顾着我。但是上了高中以

³³ *American Beauty* (1999): The film is about a 42-year-old suburbanite Lester Burnham, under the pressures of family and career, suffers a midlife crisis, becoming infatuated with his daughter's friends Angela. While his wife has an affair with her business associate, Lester quits his job, buys a new car, begins weight-training and smokes cannabis. In the end, Angela tries to seduce Lester. While Angela is in the bathroom, Lester is shot by his wife.

后，因为也是在外地上学嘛，因为比较自由，所以过的也很堕落，然后最后成绩也不是很好，然后就觉得，就是挺颓废的。就是，他是事业失败，我是学业也是有点失败那种。

Interviewer: 哦！你是读高中的是那样子的是吗？

XY: 对。恩，然后，就是原来理想不同嘛，原来上高中时候想着，我觉得很多人都是这么想的，说自己不说清华北大吧，至少南大应该能上的，什么的，但是最后发现就是情况和自己想的完全不一样，所以觉得挺失败的。 [...]

English translation:

Interviewer: Why such deep impression?

XY: (Because) I feel that (Lester) shares many things similar with me. In normal times, many things, that he thinks, (I) feel that (we) share many similarities.

[...]

Interviewer: I guess you are only 19. How old are you?

XY: 20 years old.

Interviewer: You are only 20 years old, and you can see yourself in him? I think this is very strange, could you please explain?

XY: For example, his decadence. Actually I too had that kind of feeling. Because, actually (when I was in) junior school, (I was) counted as very much the type of (students who) achieves very good results, therefore I was looked after everywhere. But after I was sent to high school, because I studied in a place other than my hometown, therefore it's freer, therefore led a degenerate life, then the results were not very good, then (I) felt very decadent. It's kind of, his career was a failure, my study was a bit of a failure.

Interviewer: Uh huh! It was in high school when you were like that, was it?

XY: Yes. Erm, and then, because (I had a) different dream, before, when I was in high school I thought, I think many people think in this way, even if I don't get into Tsinghua University or Peking University, at least (I can get in) Nanjing University etc, but, in the end I realized, the situation was not the same as I thought, therefore (I) felt like a failure. [...]

As is shown by the underlined sentence, the main reason why XY had such deep impression of that film was because he felt he had so much in common with one of the main characters, Lester. I was a bit surprised when he told me he found many similarities with the character, due to the fact that XY, a Chinese young CCS who was only 20 years old, and the character Lester, a married 40-something-American-man who suffers from mid-life crisis, do not appear to share anything significant in common. At the time when XY watched that film he was still in high school, which means he was about 16 to 18 at that time. However, XY's comments unveil the 'mystery'. The word *failure* used by XY indicates how depressed and unhappy he might have been about his study when he was in high school. This also explains why XY had such strong sympathetic response to Lester.

Then XY continued:

(Q.6.3.1.10)

XY: [...] 然后还有一个就是那种，他不是因为喜欢一个小女孩，所以就，恩，好象下定决心，然后改造自己，什么锻炼身体，又去晨跑啊，还跑到车库里去，去举那个什么东西...

Interviewer: 那个...那个...? 对! (我们指的是哑铃)

XY: 然后, 其实我也有过, 比如喜欢一个女生的话, 我会觉得万一她不喜欢我怎么办? 应该把自己变得更厉害啊, 不管是看上去还是其他各方面, 都应该把自己变得更优秀一点, 就是包括像什么锻炼身体啊什么的。就是这种情况, 就是和他一样。其他还有, 就是, 我刚提到的一样, 就是在沙发上, 想和他妻子浪漫一下这种, 我也挺有感触的。虽然当时没有女朋友, 但是, 当时心理也有这种想法吧, 就觉得应该很浪漫的一件事, 不要被其他的比较世俗东西打扰。

English translation:

XY: [...] Then, it's like, he (Lester) likes a young girl, therefore, erm, he made up his mind to change himself, like, train (his) body, morning-run, and also lift that ... that ...in the garage.

Interviewer: That ... that... Yes! (We were referring to the weights)

XY: Then, actually, I too used to, for example, I like a girl, I would feel that what should I do if she does not like me? (I) should turn myself into a better (person), no matter whether in appearance or other aspects, should turn myself into a more outstanding (person), including things like doing physical exercise and so on. In this case, (I think) the same with him. Also others, like, as I mentioned earlier, (Lester and his wife) on the sofa, (he) wants to do something romantic with his wife, I also felt strongly towards this. Although (I) didn't have a girlfriend at that time, I also had this kind of thought at that time, I felt that such romantic incident should not be interrupted by other common and little things.

Another similarity XY identified between himself and the character, Lester, is their attitude and approach towards the girl they fancy. In the film, Lester had a crush on his daughter's friend, *Angela*, and started pursuing her by improving himself, such as doing physical training etc. XY's comments indicate that he not only agreed with Lester's attitude and approach but also, most probably, XY has done a similar thing too.

In addition, XY mentioned a scene which Lester is fooling around with his wife on the sofa. They had to stop because the wife was worried whether Lester will spill the beer in his hand on the expensive sofa. Lester got upset because of this. Although XY did not have wife nor girl friend at the time when he watched the film, it seems that XY could identify with the character and sympathize the way Lester feels.

XY then continued:

(Q.6.3.1.11)

XY: 还有他的勇气。我是经常会想到。我经常去想, 有些事我本来不想去做, 可是我想, 我在这种最年轻的时候, 如果我不去做的话, 到了中老年我更不敢去做了。到了以后回想起来, 这些事如果我做了失败了, 当然就算了, 如果我连试都没有试过肯定会后悔的。万一我成功了呢? 比如说那个女孩我非常喜欢, 很想去追她可是一直没去追, 但是这样的话我等到老了以后再回想起来, 我也许就会想, 如果我追了, 是不是就成功了呢? 也许会是一个很美好的爱情什么的。这样会很遗憾的。就会和你去追了但是没追到就很不一样了。什么事情你都要去史一样, 就要有勇气去史一样, 可以不去管它的后果, 这样会给你以后脑子的东西, 有很多回忆的地方。

English translation:

XY: And also his courage, I always remember. I often think that there are some things that I do not plan to do, but I think, when I am in the youngest time (in my life), if I do not do it, I wouldn't dare to do it when I am middle-aged or older. Later when I recall, these things, if I did it and failed, it's OK, if I didn't even try, I would definitely regret. What if I succeed? For example that girl, I like her very much, very much wanted to pursue but didn't, but until later when I am old and remember all this, I probably would think, if I went for it, maybe I would have succeeded? Probably it'd be a beautiful love etc. In this way, it'd be such a pity. It's very much different from you tried to pursue the girl but didn't succeed. You should try everything, be brave, do not care about results, in this way, in your mind, (in the future) there will be many memories.

In the film, to fight against his mid-life crisis, Lester makes dramatic changes to his life, such as quitting his job, working at a fast-food restaurant and working out to attract Angela's attention. This behaviour can be interpreted in many ways, such as Lester is being impulsive, rebellious, etc. However, XY viewed this as a good quality of Lester, his courage. He was deeply impressed with Lester's courage; he valued it a lot. XY's comments indicate that he was perhaps influenced by Lester's attitude, which was to strive to pursue the girl he desired, and he also seemed to be very much motivated by Lester and his courage. It seems that, in addition to identifying similarities with the character, the character also played a role in forming XY's view, outlook on life, and his approach to things desired. An effect on his behaviour is detected.

Last but not least, let's look at what GW said about a film that she liked, *Princess Diaries*³⁴.

(Q.6.3.1.12)

GW: 我觉得这个奶奶对孙女还是比较理解的。虽然她一开始就一直是一个贵族，一个王后，一个国家的统治者，可是她接触到一些新鲜事物文化的时候改变思想也很快，可以接受一些新的想法。我觉得跟中国没什么大的差别，因为我奶奶也很开放。她接受新事物特别快。不过相比较与中国来说，中国现在每个家长都像那样几乎不太可能的，中国家长那种，家长权威，孩子观念上特别...

English translation:

GW: I think this grandma very understands her granddaughter. Although, from the very beginning she had always been noble, a Queen, the ruler of a country, she also changed her thoughts very quickly when encountering new things and culture, (she) could accept new ideas. I think it is no different from China because my grandma is also very open. She accepts new things very quickly. However, relatively speaking, it's impossible for all the parents in all families to think like this, Chinese parents ...

GW found something similar between the grandma (the Queen) in the film and her own grandma. Both of the fictional and Chinese grandmas are open, and easily accept new ideas. Comparing to other CCSs above, what is significant about GW is that she did not generalize to say that all

³⁴ *Princess Diaries* (2001): A fifteen-year-old American schoolgirl, Mia, is visited by her grandmother, the Queen, Clarisse Renaldi, from the fictional European country Genovia. Mia learns that she is the heir to the Genovian throne and attends "princess lessons" with her grandmother. "So begins a comical transformation towards poise and princess-ness, including a media storm, jealous schoolmates, and a plot to take over her country." (2001, Official plot summary) After a period of doubt, Mia accepts the throne.

grandmas are like that. Instead she tried to be objective and took what she knew about Chinese parents into consideration.

A group of four students talked about the film *Forrest Gump* (1994), which they had all watched before.

(Q.6.3.1.13)

S1:我们宿舍有人叫你 Forrest Gump.我觉得你们的气质很象。

S4: 我吗? (laugh)

S1: 你和那个 Forrest Gump.

S1,2,3: (giggles)

S4: (giggles)我们班确实有一个 Forrest Gump,但是不是我。

S2:谁?

S3:谁啊?

S2:天啊! 和我们呵甘一样诶!

S1: 叫什么啊? 看看我们认不认识。

S4: YY,认识吗?

S1: (immediately) 哦, 我认识他, 我们是一个宣传部的。

English translation:

S1: Someone from my dorm calls you Forrest Gump. I think you two have similar characteristics.

S4: Me? (Laugh)

S1: You and that Forrest Gump.

S1,2&3: (giggles)

S4: (giggles) There is indeed a Forrest Gump in my class, but he's not me.

S2: Who?

S3: Who is he?

S2: Oh my god! Same as our Forrest!

S1: What is his name? See whether we know him or not.

S4: Do you know YY?

S1: (immediately) Ah, I know him. We are from the same Publicity group (from student union)

S1 identified similarity between the character, Forrest, and one of the interviewees S4. S4 noticed the similarity between one of his course mates and Forrest. Comparing GW and above group, what they share in common is that they identifying similarities between the fictional character and someone else who is close to them, instead of with themselves.

To sum up, what the above interview extracts have illustrated is that, although the films and TV series that Chinese college students (CCSs) watch are either produced in the U.K. or the U.S.A, CCSs sometimes recognize and identifying similarities between the characters and individuals in real life, including themselves and people who are closely related with them, such as flat-mates, course-mates, relatives etc. Similarities with the characters included views, attitudes, behaviours, relationships, beliefs, values, experience and personalities.

Several factors affect CCSs identifying similarity with the characters. First, findings from qualitative data suggest that gender plays an essential role. It seems that girls tend to identify similarity with female characters, whilst boys tend to identify similarity with male characters. Another set of factors, including CCSs' existing knowledge, views, beliefs, values and their personal experience, appear to be important in identifying similarity with the characters. Finally, another influential element is CCSs' understanding and interpretation of the characters, including the character's motivation, attitudes and behaviour.

Furthermore, in addition to identifying similarity between characters and themselves, some of the CCSs have a tendency to identify similarity between the characters and particular groups of people in the Chinese society. This may result in CCSs forming a perception about self and about the group that s/he belongs to, or may reinforce an existing perception. This has to do with the issue of the 'effect', which will be dealt with in the next chapter.

The following section will present more examples which fall into the category of 'Compare: identifying similarities between characters and Chinese people'.

6.3.2 Compare: Identifying Similarities: Fictional Character(s) and Chinese People in General

(Q.6.3.2.1)

GW: 我觉得中国现在就有有点象*Brokeback mountain*那个年代的时候。发展个再过十几二十年, 也许就会发展到象*Friends*里那样, 大家对待同性恋态度一样。

English translation:

GW: I think China now is a little bit similar to *Brokeback Mountain*³⁵, that period of time. After ten or twenty years of development, maybe we will develop to be like *Friends*³⁶ and everyone's attitude to homosexuals will be the same.

Having watched the clip *Lesbian wedding*³⁷, GW immediately started talking about her views on homosexuality. It seems that the clip played a role as a stimulus that triggered GW's existing views on homosexuality. The interview extract above shows that GW identified the similarity between Chinese people's attitudes towards homosexuality and two different fictional programs which were set in different times.

LAQ told me the things which appeared in her mind when she was viewing the clip, *Dining saloon* from the film *Titanic* (1997), which she had seen before.

³⁵ *Brokeback Mountain* (2005): The film set in 1970s America, tells stories about the forbidden love between two cowboys.

³⁶ *Friends* (1994-2004): The American sit-com TV series *Friends* is set in Manhattan, U.S.A. The show, which lasted ten years from 1994 to 2004, portrays complex stories happening around the six friends and their lives and friendship during ten years.

³⁷ *Lesbian wedding*: a clip chosen from American sitcom *Friends* (1994-2004). In the clip, Ross's ex-wife is marrying Susan. All six friends attend their wedding.

(Q.6.3.2.2)

LAQ: 我就是觉得从这个上面不是因为，他们开始说话的时候对他都很讽刺那样的，他住在3等仓，嘲笑他那样的，然后就想到中国很多地方，不知道，反正就是有一种感觉就觉得中国很多地方也是这样子的，好像觉得你有钱就可以，不管在哪个地方都很受人尊敬的样子，你要是没钱的话，比如说象在街上要饭的，他要是走到一个饭馆面前怎么怎么样，他肯定会被赶出去，好像人的同情心还有本能的那种，良知啊那些东西好像慢慢就没有了。每个地方都一样我觉得。

English translation:

LAQ: [...] I feel that, in the film, when they started talking to him, they were very ironic to him, he lived in the third-class cabin, laughing at him. Then, (I) thought about many things in China, I don't know, anyway, I kind of feel that many things in China are also like this. It seems that as long as you are rich, (you) will be respected by people no matter where (you are), if you are poor, for example, beggars on the street, if he go to the front of a restaurant and so and so, he'd definitely be thrown out. It seems that people's basic instinct of being able to sympathize, conscience, things like that, seems slowly disappearing. Every place is the same, I think.

The characters, the rich passengers and Jack, as well as how they treated Jack, made LAQ think about things in China which appear to be similar, such as, the rich and the poor and how the rich treat the poor. The example which LAQ used to illustrate her point shows her understanding and view of the rich and the poor developed from her experience in China. Comparing LAQ with examples shown in the previous section, what seems to make LAQ different is that she did not identify similarities between the characters and particular individuals, such as herself. Instead, she identified similarities between the characters and particular groups of people in China, the rich and the poor.

What LAQ said in the end particularly drew my attention. It seems that she reached a generalized idea about the rich and the poor not only in China, but also every other place. It would be reasonable to speculate that LAQ most probably was referring to people represented by the characters, such as Americans and British. Interestingly, where did LAQ get this idea? Was it her existing view on this matter or was it from what is shown in the film? It could be either or both. The viewing experience, in particular, identifying similarities between the characters and equivalent groups of Chinese people, seems to play an important role in forming or enhancing a viewer's view.

Let's look at another example from CM who viewed the same clip as LAQ. She had watched the film *Titanic* before. After explaining what happened in the clip, CM continued:

(Q.6.3.2.3)

CM: 我觉得,首先,英国有很大等级差别,穷人和富人生活是不一样的,生活习惯也是截然不同... 反正,中国不是也是一样的吗? 就是一些达观贵人对穷苦百姓也不是一样的,只是换一个国家换一种方式吧了。

Interviewer: 中国是什么方式?

CM: 中国 ... 首先, 一个是‘零落绸缎’一个是‘粗布麻衣’。还有一些吃饭的 ... 吃饭的达观贵人家里分上坐下作, 一般家庭不会分的。然后 ... 贵人们也会比较虚伪的虚寒温暖, 老百姓就是比较朴实的问话。

English translation:

CM: I think, firstly, there is huge difference between classes in the U.K., life of the poor and the life of the rich are different, living habits are completely different ... anyway, isn't China the same? Those high officials and people with high status treat the poor common people the same (way), it's simply different way in different country.

Interviewer: What is the approach in China?

CM: China ... first of all, one is '(wearing) silks and satins', one is '(wearing) coarse cloth and hemp garment'. And those eating (manners) ... eating in high officials' and the rich' families, there are upper-seat and lower-seat, whilst there isn't such difference in common families. Then ...those high officials and rich people are also very hypocritical and pretend to inquire after (someone's) well-being, the ordinary people would inquire sincerely and honestly.

Although the film *Titanic* is based on a true story, most of the characters in the film are fictional, with several exceptions, such as the *captain, designer of the ship, the band* and some of the *crew*. The captain, designer and the crew of the ship are British, due to the fact that *Titanic* was designed and built in Britain. In the clip, *Dining saloon*, the characters, including the rich passengers and the poor Jack, are all Americans with one exception, Thomas, the designer of the ship. Interestingly, CM, for some reason, got the idea that those characters were all British. It can be speculated that CM got this idea from the fact that she might have noticed that the ship was sailing from Britain, and hence, most of the passengers should be British. Alternatively, she associated this sort of class behaviour between the rich passengers and Jack with what she already knew about or thought of British. In other words, some of the behaviours of the characters matched with CM's existing impression of the British. This might also have something to do with the fact that she probably was aware that the actress Kate Winslet, who played as the character Rose, is British.

In addition, as the underlined sentences indicate, like LAQ in the previous example, CM not only noticed the contrast between the rich passengers and Jack, who is poor, but also identified similarities between those characters with equivalent groups of people in China, including 'high officials and people with high status' as opposed to 'poor common people'. The last underlined sentence indicates that CM seems to have a positive attitude towards the poor and a negative attitude towards the rich in China. This might be the result of viewing the clip, or the clip might have triggered her existing views and attitudes to the two groups of people. The possibility that clip-viewing reinforced her existing views and attitudes is also there.

Looking at comments both from CM and LAQ, in terms of identifying similarities, although the wordings they used are slightly different, what they share in common is that they both recognized

the similarities between the characters in the film with particular groups of Chinese people. In addition, the characters in the film and the equivalent groups of Chinese people fall into two categories of people which are strongly associated with wealth and status in the societies, both in the fictional world and the reality. This also reflects their views on the rich and the poor both in the film and in China.

I showed the clip *Two black men*³⁸ to GMX, who had not seen the film before. She talked about her understanding on the two characters after viewing.

(Q.6.3.2.4)

GMX: 就是他们，你歧视我们，让我们害怕，我就要买一个买一个更威胁的东西，让你们害怕我，就是对社会的危害也挺大的，对别人，本来人就是人嘛，大家都应该是平等的对待嘛，对别人有一种不公平的看法，而且你对别人那种压迫越深，然后别人那种就是一腻烦心理，就是越大，如果我得势了的话，对反压迫，对以前你压迫过的人，或者是现在对待别人他就会用那种更狠的方式对待你。就是中国那种，婆婆媳妇，恶性循环，当了婆婆之后对她的以后的媳妇更狠毒了，感觉就是这种模式在不停的重复。就是觉得在美国那边种族其实还是存在的。

English translation:

GMX: They...you discriminate against us, make us afraid, I will buy something which is more threatening, to make you scared of us. This is very bad for society. For other people...actually, people should be treated equally. If you had unfair view to other people, and when you oppress others, the deeper you oppress others, the more and stronger the counter attitudes are. When I get the upper hand in the situation, I will treat you as you did to me before, only treat you in more ruthless and relentless way. It's like the kind of relationship, in China, mother-in-law and daughter-in-law, its vicious cycle, when you become mother-in-law, you are even more relentless towards your own daughter in law. It's like this kind of model is in the non-stop repetition. I think, in America, racial discrimination still exists.

Based on her interpretation of the two characters, two black guys, GMX developed her understanding and view on them, in terms of what they think, how they feel and why they do what they do (rob the white couple's car). As the underlined sentences illustrate, GMX recognized that these two characters, in particular their attitudes towards whites and the motivation of their behaviour, share similarities with some of the Chinese people, specifically daughters-in-law and their attitudes toward mothers-in-law, as well as the characteristics of their relationship. What fascinates me is that, although from surface level these two groups of people, black and white people and Chinese daughters-in-law and mothers-in-law, do not seem to be linked with each other in any obvious way, GMX managed to find something they share in common from *her* perspective.

³⁸ Two black men: The clip was chosen from the film *Crash* (2004). In the clip, one evening, on a street in Los Angeles, U.S.A., two twenty something black men rob a car from a white couple.

In addition, as the final statement made by GMX indicates, it seems that her understanding of what happens between the characters in the clip further enhanced her idea of existence of racial discrimination in the U.S.A.

The film, *School of Rock*³⁹, reminded DYY about another film with a similar subject, teacher and student, *Dead Poets Society*⁴⁰, which he liked very much. While he was telling me what the film was about, DYY pointed out several similarities he noticed between the high school in the film and the schools in China in general.

(Q.6.3.2.5)

Interviewer: 你说 *School of Rock* 让你想起死亡诗社, 能不能解释一下?

DYY: *School of Rock* 跟那个 *Dead Poets Society* 很像的. [...] 它是美国一个比较 ... 高中, 那个学校升学率挺好的, 而且那 (里的学生) 都是进名牌大学, 所以他们学校都管的挺严的, 像中国式的管理, 什么都很严格。然后里面的学生, 也许有自己的爱好, 由于有种种原因不能够, 就像中国一样, 不能够发挥和表达出来。然后那个老师, 也是以前那个大学的毕业生, 然后他回去教书, 因为他自己有这样的经历, 就回去以后 ... 他是教诗歌的, 他就教那些孩子们, 英语我忘了, 但是翻译成汉语就是说:“你有什么就要说什么, 你一定不能让你每一天都荒废”。因为他说出这样的话。。。他敢于说出这样的话我很佩服他。他一种反传统的教育方式, 他很少给学生布置作业, 听写啊, 背诵啊, 他会鼓励孩子们去自己创造诗歌, 鼓励孩子们去做自己喜欢的事情。这样一种方式我觉得真的很棒!

English translation:

Interviewer: You mentioned this film reminds you about *Dead Poets society*, could you please explain a bit?

DYY: [...] *School of Rock* is very similar to *Dead Poets Society*. [...] It's an American ... high school, rating of that school is pretty good, and they (students from that high school) all go to top universities. Therefore, their school is very strict, just like Chinese-style management, everything is very strict. Those students in the school, they have their own interests as well, but due to various reasons, (they) cannot, it's like in China, cannot be articulate and creative. Then, that teacher, (he) used to graduate from that school, then he went back to teach, because he had this kind of experience, then after he went back ... he taught poetry, he thought those kids, I cannot remember (how to say this) in English, but translated into Chinese is: “Do what you want, you must not waste every day”. Because of what he said ... he dared to say things like this, I greatly admire him. He used anti-traditional teaching approach, he rarely gave students assignment, listening, memorising, he encouraged kids to create their poems, encouraged kids to do things that they liked. This approach I think is truly great!

³⁹ *School of Rock* (2003): The film is about a rock musician, guitar player Dewey Finn, who gets fired from his band. He needs to raise some money to pay his rent and his bills. He takes a job as a 4th grade substitute teacher at an uptight private preparatory school where his attitude and approach have a powerful influence on his students.

⁴⁰ *Dead Poets Society* (1989): John Keating is a new teacher of English at Welton Academy. His unorthodox methods include encouraging students to tear pages from their textbook and having them stand on his desk. He also tells them they may call him “Captain, my captain.” Inspired by Keating, the students revive the literary club of which their English master was a member, the *Dead Poets Society*. After one of the students commits suicide, there is an investigation into Keating's teaching methods and Keating is dismissed from his post. As Keating leaves, his former students address him as “Captain, my captain”, standing on their desks.

As shown by the underlined sentences, DYY identified similarities between school and students, as portrayed in the film, with students and schools in China. Both of the similarities identified by DYY illustrate not only his understanding on the school and students in the film, but also reflect how DYY felt about Chinese schools and students in general. Looking at DYY's comments, the phrases he used, such as 'strict' and 'cannot express' etc, indicate DYY's negative attitudes towards traditional approaches both in the film and China. Meanwhile, the rest of the text extract, especially the last underlined sentence, demonstrates how much DYY admired the teacher and his positive attitudes toward the teacher's approach to his students.

Clearly DYY's perception of Chinese schools and students assisted his interpretation and understanding of the school and students in the film, and vice versa. His understanding of and positive attitude towards the teacher character might have, to some extent, affected his existing perception and negative attitudes towards Chinese schools and students. According to DYY's comments, it would be reasonable to suggest that DYY's understanding of Chinese schools and students as well as his negative attitudes toward them have been reinforced.

Last but not least, let's look at another example from a female CCS, GW. Among the films that GW had seen before, *Lost in Translation*⁴¹ seems to have made a deep impression on GW, and she still remembered many of the details. For example, she said:

(Q.6.3.2.6)

GW: 我其实以前一直以为,美国人,他们历史比较短,我觉得不会,象中国人,看什么东西都会产生对历史的感慨,感怀啊,见花落泪,望月生情啊那种中国人经常会这样,可是像那个女主角来到东经嘛,对窗外的高楼啊,自己在那里霞思啊什么的,然后我觉得这看起来性格更象亚洲人。都可以在傍边做诗那种。就是感觉跟一贯美国人和西方人在亚洲人心中的形象有点差别吧。他们(美国人)给我们的感觉就是嘻嘻哈哈的,他们没心没肺的那种感觉,只要今天快乐,今朝悠久今朝最,每天都活的很开心的那种。可是那个女主角她就是那个,对人生岸标,对人生有更高的境界和追求,思考人生到底是什么样的。给我的印象很深刻。

English translation:

GW: Before, I actually always thought, Americans, their history is relatively short, I thought (they) would not, like Chinese, when see things, (we) would sigh with emotions towards history, reflections, shed tears when see flowers, develop emotions when see moon. Chinese people would always be like this. But that leading lady (in the film) came to Tokyo, (she) looked at tall buildings outside of the window, fancy sitting there alone etc, and then I feel that (her) personality looks more like Asian, the kind who would write poems. (I) just feel (she) is a little different from the image, of American, which has always been in Asian people's mind. They (Americans) give us an impression that (they are) laughing and joking, they are inattentive and

⁴¹ *Lost in Translation* (2003): The film is mainly about a "relationship which more than friends but less than love affair" (Coppola, 2004) between a middle-aged American movie, Bob Harris, and a recently married American young woman, Charlotte. Bob Harris, far past his prime, comes to Tokyo, Japan for a commercial. Charlotte stays in Tokyo temporarily with her husband who is a photographer on assignment.

careless, as long as (I am) happy today, (I'll) drink all the wine today and get drunk, live very happily everyday. But that leading lady (she), her thought about the purpose of life, her higher expectation and search for meaning of life. (She) thought about what life really is. (That) gave me fairly deep impression.

The leading lady whom GW was referring to is Charlotte. As underlined sentences suggest, GW felt that Charlotte's personality was quite similar to Asian instead of American. In other words, this American young woman's personality matches with the characteristics of Asian in GW's framework of knowledge rather than images of Americans that GW always had. The fact that GW identified the character with *Asian*, instead of Chinese, indicates that it seems GW had particular image, the kind of image that Chinese and people from other Asian countries share in common. However, in general, when Chinese people use the word Asian, they refer to East-Asian. This means, GW not only identified similarity between the character with Chinese, but also with East-Asian people in general. In doing so, a challenge to her existing stereotype of Americans is detected.

In addition, the similarity between the character and East-Asian people, as well as the difference between the character and the stereotypical American, seem to be the main reasons why GW was confused and had such deep impression on this bit of the film. Clearly, GW's interpretation on the character, Charlotte, as well as her existing knowledge and idea on both American and East-Asian people, including Chinese, played an important role in her process of making sense of the film.

Before moving on to next section, let's look at final example. After viewing the clip, *Director*, from the film *Crash*, GW, who had not seen the film before, said:

(Q.6.3.2.7)

GW: 我大概看明白了。我就觉得这两个人吧，这个白人，拍电影当中黑人说了一句话，然后他就觉得那个黑人说的话不符合黑人的表达方式，他用了白人表达语言的方式，他就觉得预约了他的身份和肤色。然后他让他该过来。但是我觉得他是，要求改的是个白人吧？他有自己的种族的文化，他也许就是挂念里面还是有一些discrimination。然后他就得强迫，他就感觉...我们那个时候老师跟我们说过，很多人就喜欢贴标签，把一类的人归到一类，就是说我们一谈到英国人，就觉得很绅士很古板什么的，就很容易刻板印象给人家贴标签。属于那种，谈到黑人，他就觉得黑人就得用这样的方式说话。但是因为这个导演他自己是个黑人，他就很能理解这个黑人说这种话的感觉吧。两个人之间产生矛盾和摩擦了。我觉得这个白人还是对黑人有很大偏见的。感觉像中国古代那种说话也是分等级的啦，就是皇上才可以叫朕，叫寡人什么的，不能预约身份还有等级地位。在他们那边反映在肤色之间那种，不能越过界限吧。

English translation:

GW: I think I generally understand (what happened). I think these two people, this white person, during shooting, a black person said one sentence, and he (the white person) thought what that black person said did not fit black people's way of talking. He (the black actor) spoke in the white's way. He (the white person) felt that he (the black actor) went beyond his identify and skin color. Then, he asked (the black

director) to change it back. But I think, the person who asked for this is white. He has culture of his own race, probably in his mind, there's also some discrimination. Then, he'd force, he thought ... at that time, our teacher told us before, many people like to label, group people into groups, that is to say, when we talk about British, we'd think they are gentle, old-fashioned etc, easily label others due to stereotype. He's like that, when talk about the black, he then thought, the black should talk like this. But, because this director, himself is black, he understood this black (actor) very much. As a result there was friction and conflicts between them (black and white directors). I think this white person has bias towards the black. It feels like in ancient China, there's different ranks with the way people talk, that's to say, only emperor can call himself Zhen⁴², and Gua Ren⁴³ etc, cannot go beyond status and positions. (Same thing) reflected by between skin colors on their side, cannot cross the line.

GW recognized the similarities between the characters, Cameron (the black director) and the white guy (member of the crew), and the emperor and common people in ancient China. More specifically, what GW found they share in common is the difference, boundary and hierarchy between two characters with different skin colors and ancient Chinese people with different social status. It is interesting that GW managed to identify similarities between fictional characters a foreign film which set in 21st century U.S.A., with some of the Chinese people in ancient China. What she did crosses borders and time. GW's understanding of the characters and her knowledge, views etc of Chinese people play an important role.

All the interview extracts presented in this section fall into the same category, which is Chinese college students (CCSs) identifying similarities between fictional characters and equivalent groups of Chinese people, with the one exception of GW, who recognized similarity with the character of East-Asian people, to which Chinese people belong.

One thing worth mentioning is the words '*on their side*' (在他们那边) used by GW at the end of her comments. As mentioned in previous section, many CCSs tend to use catch-all phrases, such as 'they', 'their side' etc to indicate people represented by the characters. In the case of GW, most probably she was referring to Americans. This means, GW not only identified similarity between the characters and the Chinese people, but a tendency of identifying similarities between people represented by the characters and Chinese people is also there. This will be the focus of the following section.

6.3.3 Compare: Identifying Similarities: Generalised Group of People Represented by Fictional Character(s) and Chinese People in General

I showed the clip, *Shop for gun* from the film *Crash* (2004), to a group-of-four CCSs. I asked them whether the clip helped them learn anything about Americans, one of the female CCS said:

⁴² Zhen means 'I' in ancient Chinese. This word was only used by Chinese Emperors.

⁴³ Gua Ren means the royal 'we' in ancient Chinese. Same as Zhen, the words were only allowed to be used by Emperors.

(Q.6.3.3.1)

S1: 我觉得美国人自身，他可能自己不觉得，但是做为外国人会可能对这个比较在意吧，就想我也是，上海人和美国人有点像，因为上海人，不是说上海人看不起外地人嘛，然后象我这种上海人根本不觉得上海人怎么样，大家都是中国人，都一样，但是我来到北京以后，来北京之前，我姐姐在北京上大学，说你到了外地千万别说你是上海人，要说你就说你是南方人。不然人家会不喜欢。我们宿舍还可以吧，后来有一次和别人聚餐，和上海男同学，他带了一个外地的同学，他说，中国一共有良种人，一个是上海人，一个是外地人。然后就感觉有点像，本事自己是没有认识到这个问题，但是别人会知道这件事情就很敏感。

English translation:

S1: Racial discrimination. I think Americans themselves, they probably are not aware, but, as foreign people, probably care very much. For example, me too...I think, there's a bit similarities between American and people from Shanghai. People say that people from Shanghai look down upon people from other cities. Actually, people from Shanghai, like myself, absolutely do not think anything special about us (people from Shanghai), we are all Chinese, all the same. But after I came to Beijing...before I came to Beijing, my older sister who was in Beijing University, told me that: "You must NOT tell others that you are from Shanghai, tell them that you are from the South, otherwise, others will not like you." Things are ok in my dorm. But, there was one time at a gathering, with a course-mate who's also from Shanghai. He came with bunch of students who are not from Shanghai. They said: "there are two types of people in China. One is people who are from Shanghai. The other is people who are not from Shanghai."

S1 identified similarities between not only characters but also peoples represented by the characters, Americans and foreigners, with Shang Hai Ren⁴⁴ (people from Shang Hai) and the rest of Chinese population. S1's view on Americans and foreigners, as well as their attitudes towards each other, seems to be affected by her understanding of what happens among the characters in the film. Second, as a person from Shang Hai, S1's knowledge gained from her sister, as well as experience in the college social life, played an important role in forming her view on Chinese people, in particular, Shang Hai Ren and other non-Shang Hai Ren; as well as her interpretation of the characters and peoples represented by the characters.

I showed the clip, *The noble right*⁴⁵, from the film *Brave Heart*⁴⁶, to two students JT and TXH who both had watched the film before. After viewing the clip, JT said:

⁴⁴ Shang Hai is the largest city and most metropolitan city in China. Ren, in Chinese 人, refers to person and people. Therefore, Shang Hai Ren refers to person/people from Shang Hai, China.

⁴⁵ The noble right: The clip was chosen from the film *Braveheart* (1995). In the clip, on the day when William Wallace returns his hometown in Scotland, there happens to be a wedding. Including Wallace, while everyone is dancing happily, musicians stop playing as a group of armed horseman with banners ride into the midst of the festivities. An English nobleman stops in front of the bride and announces that he has come to claim 'prima noctes', which is the English noble's right to take Scottish bride's first night. The bride's father and husband tried to stop but couldn't because the horsemen point their lances at the villagers. In the end, the bride was taken away.

⁴⁶ *Braveheart* (1995): A fictionalized account of William Wallace's fighting against the English for the "freedom" of occupied Scotland, *Braveheart* traces Wallace's exploits from the revenge-killing of a sheriff and the storming of a castle to the sacking of York and his defeat at the Battle of Falkirk. After a period in hiding, Wallace is captured and taken to England, where he is tied, convicted, and hanged.

(Q.6.3.3.2)

JT: 我觉得太野蛮了。

Interviewer: 谁野蛮?

JT: 就是那个抢新娘的那个人。给人的感觉就有点像，政治经济学书上写的那个，当时资本主义发家的时候，强占劳动人民的土地啊什么的，有那种感觉（笑）... 然后，就是，我不太了解英国这方面的历史，也不知道，因为现在，英国分成几部分，不太了解它的历史，可能就是因为当时民族，他们是不同民族的吧？

Interviewer: 对。

JT: 就是 Scotland 和 England，就是这种民族，好象是 England 先发展起来后，就侵占原始民族他们的领土啊什么的，就觉得，当时在想英国的一个历史问题，他在历史上如何形成现在的规模。而且，英国不是一段时间和爱尔兰有矛盾，就是因为北爱尔兰的问题 ... 就是大概能看出来英国的一些，就是有点象中国历史上的三国啊，那些历史，最后又融合成一个中国。大概就是觉得有点像这个。

Interviewer: 就是通过战争?

JT: 就是野蛮的掠夺 (笑)。

English translation:

JT: I think this is so cruel.

Interviewer: Who is cruel?

JT: That person who seized the bride. It feels a bit like what's described in the Politics and Economics textbooks at the time when the Capitalism was building up the fortune, occupying working people's land etc, that kind of feeling (laugh) ... then, it's, I don't quite know this aspect of the history of Britain, I also don't know, because now, how many parts in the U.K., (I) don't quite know it's history, probably it's because of the peoples at that time – they are different nations, are they?

Interviewer: Yes.

JY: It's Scotland and England, is this kind of nation, it seems English developed first, then invaded primitive people's land etc, feels like, at that moment (when I was watching the clip, I was) thinking about Britain's history, how it became its current scale. Plus, there's time when England had a problem with Ireland, it's because of the issue of Northern Ireland ... (I can) generally notice some, it feels like the Three Kingdoms in the Chinese history, that history, in the end (they became) one China. Generally it feels like this.

Interviewer: Through wars?

JT: It's brutal plunder (laugh).

JT sees the union of the kingdoms of the U.K. as similar to the Three Kingdoms⁴⁷ of China. This view is developed from her understanding of the character and her knowledge of three nations in the U.K. and the history of China. Lacking detailed knowledge of the specific historical context of the film, JT used more general historical information, such as the U.K. being made of three different nations, and the conflict with Ireland, to help assist her understanding.

Braveheart, set at the turn of the 14th century in Scotland, is about a Scottish hero, William Wallace, who leads his people in a rebellion against the tyranny of the English King. Both England and Scotland, during the time from 13th to 14th centuries, were still in feudalism. Capitalism did not start until two centuries later. JT's view that the cruelty of the character that seizes the bride

⁴⁷Three Kingdoms (三国): is a period in the history of China, part of an era of disunity called the Six Dynasties. It refers to the period between the foundation of the Wei in 220 and the conquest of the Wu by the Jin Dynasty in 280. The three kingdoms were Wei (魏), Shu (蜀), and Wu (吴).

is related to early capitalism, and in particular the idea of 'seizure of land', as taught in her textbooks, is interesting.

What the above exemplary interview extract illustrates is that, whether or not CCSs apply the correct relevant knowledge, making sense of foreign films depends on their existing framework of knowledge of foreign people and countries, as well as Chinese people and China.

Let's look at another example from GW when she was talking about an American film, *Brokeback Mountain*.

(Q.6.3.3.3)

GW: 其实, 同性恋在美国好象也挺不能被接受, 不然 *Brokeback Mountain* 怎么会里面写那两个男的在一起也挺遭家里人反对的? 特别是他们那种, 一开始结婚了, 然后又变成同行恋, 感觉有双性恋倾向那种。象他们肯定不会太接受。但是我觉得, 这方面我觉得, 中西方还是有点共同的吧。其实我觉得美国这个社会, 不一定所有的人都能接受这种现象吧, 中国也是。就是老一辈的人吧。就象我们大学生身边的人, 这些我就觉得可以接受。他们说, 都是爱, 只是爱的对象不一样。

English translation:

GW: Actually, homosexuals in the Unites States do not quite seem to be accepted, otherwise, in *Brokeback Mountain*, how come those two guys' families against them being together? Especially when they, they got married at the beginning, then became gay, then, feels like bisexual. They (people around two guys) definitely cannot accept this. But I think, in this aspect I think, China and the west shares similarities. Actually I think, American society, not necessarily everyone can accept this phenomenon, so is China. For example, old generation (cannot accept). For example, us, university students, I can accept this. People say, it's the same love, it's just the person whom (you) love is different.

GW's comments indicate that she most probably developed the idea of to what extent homosexuals are accepted in the U.S.A. from viewing the film. Based on what she 'learned' about Americans from the film as well as what she already knew about Chinese people's attitudes towards homosexuals, GW saw similarities between people from two countries, the U.S.A. and China.

Now, let's look at what GW said about another film, *Princess Diaries*⁴⁸. In another text extract from GW presented in the first section in current chapter, GW identified similarity between her own grandma and the character, the Queen, who is also a grandma, in the film. In addition, GW said:

⁴⁸ *Princess Diaries* (2001): A fifteen-year-old American schoolgirl, Mia, is visited by her grandmother, the Queen, Clarisse Renaldi, from the fictional European country Genovia. Mia learns that she is the heir to the Genovian throne and attends "princess lessons" with her grandmother. "So begins a comical transformation towards poise and princess-ness, including a media storm, jealous schoolmates, and a plot to take over her country." (2001, Official plot summary) After a period of doubt, Mia announces her acceptance of the throne at the Genovian Independence Day Ball.

(Q.6.3.3.4)

GW: 我觉得*Princess Diaries* 对我挺大的感触就是，因为那个公主,她本来是生活在美国嘛，可是她的奶奶是一个欧洲那边的一个皇族。他们在 ... 其实觉得英美两个国家还是有很大差异的，英国比较古老传统，结果她们两个在一起发生很多摩擦碰撞啊，就是感觉古老的思想 and 现代美国人的文化进行一种冲撞那种感觉。就是她和奶奶之间经常会发生矛盾啊，她会比较随意吗，不像贵族那样举止优雅啊什么的，有点象外国版的“还珠格格”了。

English translation:

GW: I think *Princess Diaries*, what stirred my feelings most is that, because that princess, she used to live in America, but her grandma is a royal member over there. They are ... actually I think U.K. and U.S.A., two countries share great differences. U.K. is fairly old and traditional, as a result, when both of them were together, there were lots of conflicts and crash, it feels like, old thinking is clashing with modern American culture. Conflicts often happened between her and her grandma. She's relatively relaxed, unlike the nobles with elegant manners. It's a bit like foreign version of *Princess Pearl*⁴⁹.

Two things strike me from GW's comments. First, GW perceived the U.K. as traditional, whilst she viewed the U.S.A. as comparatively modern. It seems that she most probably got this idea from the characters in the film, the Mia (granddaughter), and the Queen (grandma). Alternatively, even if she might have had this view already before viewing the film, it can be speculated that viewing the film reinforced this view. However, all the characters and the country in the film, Genovia, are fictional. Where did GW get the idea of that the country is the U.K.? This is possibly due to GW's lack of information about what happens in the film, such as the fact that the country, Genovia, supposedly in Europe, does not actually exist. Even though there are indications in the film that the country is not the U.K., GW did not pick them up. It seems that certain things portrayed in the film matched GW's existing knowledge and impression of the U.K., such as the Queen, nobles, and being traditional. This example shows that, when making sense of foreign films, CCSs do not always fully comprehend what is happening in the film. Occasionally, unexpected interpretations of foreign films and TV series are made!

Second, GW noticed some commonality between the film, *Princess Diaries*, and a Chinese TV series, *Princess Pearl*. Considering the plots of two shows, it seems that the similarities identified by GW are mainly to do with the characters and things that happen around the characters, such as a common girl becomes a Princess, conflicts between the tradition and modern, etc.

Although GW seems to be simply identifying similarities between two shows, one from the U.S.A. and one from China, the fact that GW developed her views on the U.K. and the U.S.A. based on

⁴⁹ *Princess Pearl* (1998) (还珠格格): is one of the most popular TV series in China. It is about street girl, Xiao Yan Zi, who in a mix-up ends up as a Princess (officially titled Guan Zhu Ge Ge) instead of her sworn sister. The adventures continue as Xiao Yan Zi tries to adjust to palace life, deals with the clashes happens in the palace with Emperor, falls in love with the fifth princess, and all the while trying to give her sworn sister back the title of Princess (IMDB, 2009).

her understanding of the characters makes me wonder. Did GW perceive Americans as the street-girl, Xiao Yan Zi, and the British as members of the royal family?

6.3.4 Summary

The current section has illustrated another main category of sense-making activities, 'compare: identifying similarities', which emerged from empirical data, with regard to how Chinese college students (CCSs) make sense of films and TV series produced in the U.K. and the U.S.A.

In a similar way to identifying differences, CCSs identify similarities on three levels. First, sometimes CCSs identify similarities (IS) between fictional characters and themselves, and occasionally with individuals who are closely related with them or play a significant role in their lives, such as grandma, course-mates, flat-mates and friends.

Second, at times CCSs recognize similarities between fictional characters and groups of Chinese people. On this level, 'groups of Chinese people' are of two types. One type of group refers to the groups which the CCSs themselves belong to. This usually happens when CCSs identify similarities between characters and themselves and other individuals close to their lives, and then tend to generalize their view from individuals to the larger group which they belong to. The second type of group does not seem to include CCSs themselves in any obvious way, but appears to have things in common with the characters. One special case is GW and her interpretation of the character from *Lost in Translation*. She identified similarity between the character and East-Asian people in general, which goes beyond the boundary of China.

Finally, occasionally, CCSs identify similarities between groups of people represented by the characters and groups of Chinese people.

Four main variables which affect identification of similarities have been identified. They are interpretation of characters, knowledge, life experience and gender.

As illustrated by examples in the section on 'comparing: identifying differences', CCSs' knowledge and life experience play an essential role in making sense, whether they view a clip or a whole film. CCSs' process of identifying similarity always involves the application of their interpretation of characters and their behaviour, knowledge of the other peoples and cultures represented by the characters, as well as the knowledge of themselves, the Chinese people and their culture. Due to the fact the films, including characters, events, etc, are foreign in nature, sometimes lack of relevant knowledge results in an unexpected interpretation.

In addition, the variable of gender stands out in the process of 'comparing: identifying similarities' in particular. The gender factor did not appear to be significant in the empirical data illustrating

the process of ‘comparing: identifying differences’, but was very evident in the data illustrating ‘comparing: identifying similarities’.

CCSs are highly diversified in terms of interests, framework of knowledge on self and others, life experience, beliefs and values. Framework of knowledge, life experience and interests appear to be gender specific. Every student is a complex individual with her or his own characteristics. As a result, due to the nature of diversity within unity, CCSs’ sense-making activities are culturally specific, unpredictable and highly variable.

The following section will focus on another main category of sense-making activities, ‘re-contextualizing’, which also emerged from the empirical findings.

6.4 Re-contextualizing

“I am more than certain that Chinese college students are rarely passive viewers. There are so many things going on in their mind. Never underestimate the power of imagination one has when making sense of foreign films.” (My memo on the 21st Oct 2009)

Previous sections have identified several main categories of sense-making activities from examination of the empirical data. They are ‘comprehending the plot’, ‘compare: identifying differences’ and ‘compare: identifying similarities’. The current section will focus on another main category of sense-making activities which can be broadly termed ‘re-contextualize’. According to the Oxford Dictionary, ‘to contextualize’ is “to consider something in relation to the situation in which it happens or exists” (2000:267). Hence, the new term with the prefix ‘re’ suggests ‘to think about or reflect on something heard and/or seen in a *different* context’. One might ask how CCSs re-contextualize what they watch during the process of making sense of foreign films or clips of films, and what the re-contextualisation has to do with intercultural learning. This chapter will address this question step by step.

6.4.1 Re-contextualizing Fictional Character(s) in a Personal Context

A female CCS, GW, talked about the characters Bridget and her gay friend Tom after viewing the clip *Prepare for launch*⁵⁰, from the film *Bridget Jones’s Diary* for the first time.

(Q.6.4.1.1)

GW: 我觉得他们就是比较多元化的那种，她可以接受 gay 什么的。像...怎么说呢，其实我也可以接受 gay，也可以和同性恋做朋友，但是如果这个同性恋是发生在我的家庭里，和亲属有血缘关系的那种，我不能接受。[...] 我可以和他们做朋友，但是...就是怎么说...就是涉及到（我）自身利益的时候，我就不太能接受了。其实我们在宿舍里讨论过这个问题。我们大家说同性恋我们都可以接受。现在，

⁵⁰ Prepare for launch: The clip was chosen from the British film, *Bridget Jones’s Diary* (2001). In the clip, Bridget needs to prepare for an important social occasion at her work, at which Bridget plans to entice Daniel, the man she fancies and hopes to date. Bridget turns to her close friends, Jude, Sharon and Tom, to ask for help. The clip also includes Bridget’s preparation in her bedroom, such as choosing which underwear to wear, practicing her introductory speech, etc.

(大家)不是就是说不能歧视同性恋嘛。就是...这个就是因为性取向有的人是天生的,你这个是改变不了的,没有原因,没有理由去歧视人家。但是怎么说呢...如果(同性恋)是...比如说我的孩子,或者怎么样,这个我真的接受不了。 [...]

English translation:

GW: I think they are very kind of diverse, she can accept gay etc. For example, how to say, actually I also can accept gays, and be friends with homosexuals, but if this gay was in my family, and was related by blood, that kind, I cannot accept it. [...] I can be friends with them, but ... how to say ... when it involves my own interests, I cannot accept. In fact, we discussed about this in the dorm. We all said that we could accept homosexuals. Nowadays, (people) all say that homosexuals should not be discriminated. It's ... this is because some people's sexual preferences are born like this, you cannot change this, no reasons, no excuse to discriminate them. But how to say ... if (a homosexual) was ... for example my child, or someone like that, this I really cannot accept. [...]

There are two levels of re-contextualisation here. GW shows tolerance or acceptance of gay culture and homosexuality and has no problem discussing it with her flat mates in China. What is more noteworthy in this quote is that, for some reason, GW went a step further by imagining (or re-contextualizing) Tom as a family member. Her comments indicate that she clearly has boundaries in terms of to what extent she can accept and tolerate gay culture in her personal life. It can be seen that, fundamentally, she does not accept homosexuality, because her intolerance of a family member (a more significant member in her society) being gay is clearly more telling/revealing than her 'tolerance' of others who are gay.

PP, another female CCS, talked about the things that had made a deep impression from the film *Coyote Ugly*⁵¹.

(Q.6.4.1.2)

PP: 一个是独立。他们...美国孩子真的是很独立.而且家长也很赞同,她就是可能也就是 18, 9 岁吧.就是因为(她)自己有一个梦想,她就可以放弃一切,她就可以自己般出去住。她本来就是在一个单亲家庭,然后她就离开她父亲,就般出去住,住在一个挺破的房子。然后自己要去出去找工作,养活自己。我觉得在中国,这种情况太少了。就是说,按她的年龄,她应该上大学,她已经有了大学生活了,然后家庭也挺好了, 如果在中国,我已经有这么好的生活,我何必 ... 虽然我也有梦想,但是我何必为了自己的梦想那么辛苦,我觉得不值得,放弃那些不值得。

English translation:

PP: One is independence. They ... American kids are truly very independent. Plus, parents are also supportive. She is probably only about 18 or 19 years old. Simply because (she) had her own dream she gave up everything; she moved out (from home) and lived on her own. She's from a single-parent family, and then she left her dad, and moved out, and lived in a fairly run-down house. Then (she) went out on her own and looked for job, supported herself. I think in China, this kind of situation is

⁵¹ *Coyote Ugly* (2000): This American film is about 21-year-old aspiring songwriter Violet leaves her childhood home for New York City. After trying unsuccessfully to gain the support of any music studios, she takes a job as a bartender at the public house *Coyote Ugly*. Working there gives Violet the confidence to overcome her stage-fright and perform her songs.

too rare. (I) mean, according to her age, she should have gone to college, already had college life, and have got a good family. If it was in China, I have already got such a good life, there is no need for me to ... although I too have dreams, but there is no need for me to work that hard for my dreams. I think it's not worth it; to give up that much is just not worth it.

PP reacted strongly to and had deep impression of the leading character, Violet, including her behaviour and things happened around her. On the basis of her interpretation of Violet, as the underlined sentences show, PP re-contextualized Violet's situation in her personal context, and imagined what she would do. Although PP started by saying 'if it was in China', which makes it look as if she was referring to a more generalized Chinese context, the rest of her comments, such as 'I already have such a good life', suggest PP's statements were on a personal level.

In addition to imagining her own reaction in Violet's situation, it seems that PP developed a generalized view of what most Chinese would do in the same situation. Also, as the first underlined sentence suggests, PP seemed to develop a generalized view on American young people and parents based on her understanding of the characters. It is possible to speculate that the view already existed in PP's framework of knowledge and was reinforced by her interpretation of the character Violet.

The two examples above show that, when making sense of films and TV series produced in the U.K. and the U.S.A., Chinese college students (CCSs) sometimes re-contextualize fictional characters in their personal settings.

Two factors may play main roles in this type of sense-making activity: the interpretation of the characters; and knowledge of self and personal settings.

6.4.2 Re-contextualizing Fictional Character(s) in the Chinese Context

DYY talked about the main character, the teacher Dewey, in the clip *Step off* from the film *School of Rock*, which he had seen before.

(Q.6.4.2.1)

DYY: 就像中国的话, 就不可能出现这种情况。如果出现这样的老师, 很迅速的就被抄了。而且孩子也会觉得很惊讶, 怎么会有这样一个老师, 也许他们本身就无法接受这样一个老师? 他本身也许就会跑去告状啊什么的, 不要这样一个老师, 这个老师不好。这个肯定是有很大文化差异。 [...]

English translation:

DYY: For example, in China, it's impossible for this kind of situation to happen. If this kind of teacher appeared, (he'll) quickly get fired. Plus, kids will also feel very surprised: how come there appears such a teacher? Perhaps they would run (away) and complain that they don't want such kind of teacher, that this teacher is not good. There are definitely huge cultural differences. [...]

DYY re-contextualized the character, Dewey, in the Chinese context. What is interesting is that DYY imagined not only how Dewey would fit into Chinese schools, but also how Chinese kids would react to such a teacher. What were the reasons behind him being so sure that a teacher like Dewey would not survive in the Chinese schools, and that the kids would not put up with a teacher like him? Probably the reasons are DYY's views on how Chinese teachers normally behave in the class and the students' expectations and attitudes towards teachers. For example, perhaps his experience of being a student all the way from primary school to the college in China made him believe that Chinese teachers should be serious, and not like Dewey, who seems to be quite relaxed and can joke with students. Also, DYY might think that Chinese students would not accept such teacher because they regard teachers as authority, and would never challenge them. Nonetheless, DYY's interpretation of the character Dewey together with his existing view and knowledge of Chinese schools and students appear to be two main factors in the process of re-contextualizing. As a result, it can be speculated that DYY's perception of Chinese schools and students was to some extent affected, and possibly reinforced, by his making sense of the film through re-contextualization.

A female CCS, JT, had a lot to say about *Sex and the City*⁵², an American TV series that she had seen before. The text extract below is part of her comments.

(Q.6.4.2.2)

JT: [...] 然后我就去看 *Sex and the City*。后来我发现，自己根本和它们不是一个世界的人。就觉得思维完全是脱节的。我在想那个，因为他们都是对那种，不讲爱的，只谈性的那种人，她们这几个女人。她们生活满好的。如果把她们的思想拿到中国来的话我觉得这样的人可能会被口水淹死!我觉得她们完全跟我们不是一个思想的人了.[...]

English translation:

JT: [...] Then I watched *Sex and the City*. Later on I realized I'm completely in a different world with them (the characters). (I) felt that (our) thinking is completely incompatible. I was thinking this because they were all the kind of people who don't talk about love, just about sex, these women. They lived pretty good lives. If (we) moved their kind of thinking to China, I think people of this kind would probably be drowned by people's spit! I think they are people whose thoughts are completely different from ours. [...]

The four main female characters in the show *Sex and the City* are four American women in their thirties and forties in Manhattan, U.S.A. JT developed her views of the four characters by viewing the show. It is clear that JT reacted with great intensity. As the underlined sentence illustrates, JT re-contextualized the characters by imposing their ways of thinking and attitudes towards sex and

⁵² *Sex and the City* (1998-2004): The American TV series, *Sex and the city*, is about the friendship and relationships of four middle-aged American working women. Narrated by Carrie Bradshaw, a column writer in new York City, this romantic comedy series follows the lives and loves of Carrie and her three best friends, Samantha, Miranda and Charlotte.

love on a group of Chinese women in a similar situation, and imagined what things would be like for women of this kind in the Chinese context. In doing so, it seems that JT noticed a huge contrast and cultural clash not only between the characters and herself, but also the characters and Chinese women in general. In the process of undertaking re-contextualizing and comparing activities, JT's interpretation of the characters and her existing knowledge of Chinese people played important roles.

I showed a clip, *Women and children first*⁵³, from the film *Titanic* to WZT who had watched the film before. After viewing the clip, she immediately said:

(Q.6.4.2.3)

WZT: 这个要是以前看的话,也就真的不会去想,但是,现在再看,他的那个建议,就是让妇女和儿童先上船,我觉得这个,在中国,是做不到的。这个在中国肯定是做不到的。这个你说,现在挤个工交车啊,你说要真有这个规定,你说妇女和孩子先上,先别说妇女了,妇女她毕竟和中年的男人是一样的嘛。你说让妇女和孩子先上,我们虽然也算不上孩子的话,但是基本上属于比大人肯定要小一点了,肯定都不会让你上的。现在中国,我觉得两个国家真的是,美国和日本,要中国学习的方面那么多。我觉得这种细节上表现的特别明显。就像他这样子妇女和孩子先上,当时你就,比如说会不会采纳,当时我觉得,如果放在中国的话,提这个意见的人都不会有。提这个建议说妇女和孩子先上?肯定你什么建议都没有,就一窝蜂全上(船)去了。我们同学,前两天,去西客站买票,就比如说开那个窗口,他们那个窗口特别奇怪,他先开一个,大家都涌到这了。然后,过了半小时,他开了旁边一个,然后一群人涌过去了。然后,半个小时以后,又开另外一个,一群人又涌到另外一边去了。根本没有什么排队啊,先让着点什么什么。基本上就是,普遍看,整个中国那么看的话,相当少了,那种人,特别特别少。

English translation:

WZT: When I watched this in the past, I probably would not think (about this). But, when I watch this again now, his proposal, (the one that) women and children first (to get on the boat), I think this, in China, (Chinese people) would not be able to propose this. This would definitely not be proposed. For example, nowadays (when people) get on a bus, if there's really such rule, let's say women and children get on (the bus) first, although we do not count as children, basically (we are) younger than adults, (they) would definitely not let you get on (the bus) first. China these days, I think there are actually two countries, U.S.A. and Japan, there are so many things that China needs to learn (from those two countries). I think (the differences) are particularly obvious in these details. For example he (proposes) women and children first, at that moment, whether (people) are going to accept (the proposal) or not, at that moment I felt, if it was in China, there would not even be such a person to make this suggestion. To suggest letting women and children first? There definitely wouldn't be such a suggestion; (people) would be like a swarm of bees (to get on the boat). My course-mate, a couple of days ago, went to buy train tickets at the (Beijing) West Train Station. For example, opening the window, their window is very strange,

⁵³ Women and children first: This is the clip which was chosen from American film, *Titanic* (1997). In the clip, after the captain was informed the ship which can come and rescue will not arrive until 4 hours later. The ship's second officer, Lightoller, asks the captain whether to get the women and children into the lifeboats. The captain nods abstractly. Flares are sent up as water continues to flood the decks. Lightoller orders the crew to load the lifeboats. The band plays a waltz as Lightoller invites women to step onto the first lifeboat.

one opened first and everyone swarmed towards it. Then, half an hour later, the one next to it opened, and then a crowd swarmed over. Then, half an hour later, again another one opened, and a group of people again swarmed towards another side. (There) wasn't anyone to queue, (nor) compromise etc. Basically, overall, looking at China generally, quite few, that type of people, very very few.

WZT's immediate reaction and the length and richness of her comments show how strongly she felt about the 'women and children first' suggestion proposed by the crew of the Titanic. As underlined sentences indicate, WZT frequently re-contextualized the event which happens in the clip in the Chinese context and imagined how Chinese people would respond. It seems that WZT's speculation of Chinese people's reaction to the incident is heavily affected by her personal experience, her knowledge of what her course-mate experienced, together with her existing perception of Chinese people in general.

In addition, WZT's speculation about the reaction of Chinese people to the incident triggers a comparison between Chinese and people from the U.S.A. and Japan. What might have happened in her mind was that she formed view of Americans based on her understanding on the characters in the film and her existing knowledge on Americans. Although the character who proposes 'women and children first' is British and the rest of the characters in the clip are British and American, WZT probably perceived those characters as Americans, because the research findings suggest that CCSs cannot always distinguish between Americans and British. Surprisingly WZT also mentioned the Japanese, but there is nothing from the clip that suggests anything to do with Japanese. WZT probably had already developed certain views of the Japanese and the differences between Japanese and Chinese. These views were brought out by the re-contextualizing activities. WZT's comments indicate that she has rather positive views and attitudes towards Americans and Japanese, but comparatively negative perception and attitudes towards Chinese in general. WZT's perception of and attitudes towards Chinese, American and Japanese seemed to have been reinforced through the re-contextualizing and comparison activities.

As the first sentence in her comments indicates, WZT noticed that her reaction and interpretation of the same film have varied over time. WZT had watched this film a couple of years before. When she watched part of the same film again at the interview, she reacted to and interpreted the film differently. What made this difference? WZT comments about another clip, *Dining saloon*, from the same film, *Titanic*, answer this question.

(Q.6.4.2.4)

WZT: 这个我是在初三看的嘛。那个时候看根本没想过。但是，今天看的话，因为我们那个学法律的嘛，学法律的(学生)，我们上个学期学的是法理学。它有的地方讲到这个等级制度，因为我们，法理学讲到外国法了嘛，主要讲的就是美国，司法制度等级啊这些，美国英国德国，主要讲这三个。现在看的话，刚才

看的时候脑子里就闪了一下，但是初三看的时候没学过嘛，初三我们看是因为语文课本上有。语文课本上节选了 *Titanic*，然后我们老师就给我们放这个片子就给我们看了一边，当时纯粹是奔着爱情片去的嘛。

Interviewer: 那你脑子里闪过的是什么？

WZT: 就是等级制度。因为是自己刚学过的，马上就可以联系起来。我觉得现在，比如说，两年前看的电影和两年后看，是不一样的，因为两年前你的脑子里停留在一个阶段，因为这两年你毕竟是在成长嘛，岁月肯定不是白过的，肯定会有一些成长经验的，所以看的东西以后感觉肯定不一样的。

English translation:

WZT: I watched this when I was in the third year of secondary school. (I) Didn't think about this at that time. But, when I watched (it) today, because we study law, law (-students), we have learned Jurisprudence last term. Some parts of (Jurisprudence) mention about hierarchy. Because we, Jurisprudence referred to foreign law as well, mainly stress the U.S.A., the judicial and hierarchy system, etc, the U.S.A., the U.K. and Germany, mainly these three (countries). Now when I watch the (clip), (when I) watched it just now, it flashed in my mind, but (when I) watched it in my third year of secondary school, because I had not learned about (Jurisprudence), we watched it in the third year of secondary school was because it was in the Chinese textbook.

Excerpt from the *Titanic* was in the Chinese textbook. Then our teacher showed us this film, we purely watched the film as a love story at the time.

Interviewer: What flashed in your mind?

WZT: Hierarchy. Because I just learned about it, (I) immediately can relate with it. I think now, for example, to watch a film that (I) have watched it two years ago, it's different, because your mind stays in one stage two years ago, because these two years, after all, you are growing up, years are definitely not wasted, definitely have some experience of growing up, therefore the feeling after watching is definitely different.

It is thus clear that one's framework of knowledge and life experience play important role in making sense of foreign films. Furthermore, what happened to WZT illustrates how one's framework of knowledge and life experience change over time due to what people see, observe, learn and experience every day. Therefore, one's interpretation of the same film may not remain constant.

One more thing worth noting is that, among all the forty-nine films and TV series mentioned by CCSs, *Titanic* was the *only* film that had been seen by *all* the interviewees. When talking about things from *Titanic* that had made a deep impression, the 'women and children first' scene was the most frequently mentioned. For example, PP said:

(Q.6.4.2.5)

PP: 就是妇女和小孩先上那一幕。给我印象也特别深。怎么说呢，在中国，确实就是人的素质没有国外高，我确实就是有这么一种感觉。就是我觉得如果在中国发生这种事，肯定当时全都挤乱了。死的人更多可能得。

English translation:

PP: The scene which (is about) 'women and children first'. (It) gave me very deep impression. How to say, in China, people's deep rooted quality is indeed not as good as foreign (people). I really have this kind of feeling. I think, if this kind of incident

happened in China, definitely it'd be chaos at that time. More people probably would have died.

PP re-contextualized the incident in China and imagined how Chinese people would react and what would happen. In doing so, PP displayed a relatively negative view towards Chinese people and a comparatively positive idea about foreigners in general. The word 'indeed' used by PP when she talked about Chinese people's 素质 (deep rooted quality) not as good as foreigners' indicates that her views on both Chinese people and foreigners existed prior to viewing the film. There is no direct translation in English for 素质. 素质 is a common phrase used by Chinese to refer to individual's deep rooted virtue, talent and ability.

PP's comments indicate that she was most probably referring to people's virtue. Although PP did not specify what she meant by foreigners, and she might not know the nationality of each character in the scene, it can be speculated that PP mainly referred to Americans and British, using foreigners as a catch-all phrase (see the discussion on 'concepts of foreign and western' in section 6.2.3). Last, but not least, it could be speculated that by imagining and picturing Chinese people's reaction to the incident that happens on Titanic, PP's perceptions on and attitudes towards Chinese and foreigners with regard to intrinsic quality were reinforced.

Looking at the comments from WZT and PP on the 'women and children first' clip, both of them share similar understandings of and attitudes to this type of social phenomenon in China, and feel strongly about it.

XY, a male student, talked about *South Park*⁵⁴, an American cartoon TV series that he watched before. He had particularly deep impression of one of the episodes, although he watched it a while ago.

(Q.6.4.2.6)

XY: 你看, 那个 Philip, 有另外一个人, 就是加拿大的那个两个戏剧演员. 就因为电视上讲脏话, 然后小孩不是都学嘛, 然后就美国家长就开始投诉啊, 法律上. 最后, 弄的加拿大和美国还要打仗. 就是那种, 什么事情可以搞大吧就是。

Interviewer: 你什么意思, 搞大?

XY: 就是他们家长特别认真. 小孩从电视上学了脏话他们就立刻就这个电视有问题, 就要求停播啊之类的. 如果要是在中国的话, 可能家长会觉得这个不好, 但是只会让小孩不看, 他不会说去投诉电视台说你怎么能放这个节目啊什么的。

English translation:

XY: You see, that Philip, there's another person, (they) are those comedians in Canada. Because (they) spoke dirty language on TV, the children all imitated (them), and then American parents started complaining (about TV station), legally. In the end, it turned out that Canada and U.S.A started a war. Kind of, everything can be

⁵⁴ South Park (1997-present): South Park is an American animation sitcom series about a group of four-8-year-old schoolboys in the fictional town of South Park in the mountains of Colorado. Plots are set in motion by, often unusual, events.

exaggerated (by them).

Interviewer: What do you mean by exaggerated?

XY: Because their parents are very serious. Children learned dirty language from TV and they immediately believed something was wrong with this program and requested to stop the program. If it were in China, perhaps parents would think this program's not good, but they would just ask their children not to watch it, but they would not complain about the TV station and say, 'how could you broadcast such a program?'

XY re-contextualized and imagined how Chinese parents would react. In doing so, he identified the differences between the characters and the Chinese parents.

To sum up, the examples shown in this section have illustrated that, although the films that CCSs watch are foreign films either produced in the U.K. or the U.S.A., CCSs sometimes re-contextualize the fictional characters, including their thoughts, behaviours and situations, in the Chinese context. In so doing, CCSs tend to imagine how the characters would cope and the reactions from Chinese people. As a result, sometimes comparison activities, in particular, between the characters and Chinese, occur. Data indicates that, most of the time, comparison activities coming after re-contextualization lead to identification of differences.

Several factors play important roles in the process of this type of sense-making activity, including interpretation of characters and relevant personal experience, as well as knowledge of self, Chinese people and China. In addition, one's framework of knowledge and life experience changes over time, and, as result, making sense of foreign films and TV series may vary with time. Last but not least, sometimes re-contextualizing characters in the Chinese context may reinforce CCSs' existing perception of and attitudes towards both Chinese people and people represented by the characters.

6.4.3 Re-contextualizing Self in the Fictional Context

(Q.6.4.3.1)

SYY: 就是那两个人吧。假如说，我是那个女孩子的话，我就特别喜欢那个男生，因为他特别幽默。

English translation:

SYY: Those two people. Imagine, if I were that girl, I'd like that man very much because he is very funny.

The above comments are from a female Chinese college student, SYY, who watched the clip, *Rachel doing laundry*⁵⁵. It was the first time for her to view the clip, although she had watched some episodes of the show before. The two characters mentioned by SYY are Ross and Rachel. What SYY did here was to re-contextualize herself in the fictional setting. More specifically, she

⁵⁵ Rachel doing laundry: The clip was chosen from American sitcom *Friends* (1996-2006). In the clip, Rachael and Ross are about the wash clothes in a public laundry room. A middle-age American woman took Rachael's washing machine. With Ross's help, Rachael gets the washing machine back. Later on Rachael and the same woman struggle with the use of a cart. Rachael wins the cart by sitting in it. Ross and Rachael were both happy with the result in the end.

imagined herself as Rachel interacting with Ross. In doing so, she responded to Ross with affection.

Another female student, GW who watched the same clip, said:

(Q.6.4.3.2)

GW: 这段我看过的。我就觉得第一点，就是那个胖女人和他们争夺洗衣机。我觉得他们比较强调人权，强调自己的权利，如果，我觉得，这种事情发生在我身上，我就是觉得息事宁人比较好。因为旁边这么多洗衣机，不要为了这个洗衣机的问题和其他人产生争执啊什么的，然后成为周围人瞩目的焦点。我觉得中国人就是那种中庸态度特别强。（中国人）就不会愿意在公众场合让自己成为公众焦点，不会那么锋芒毕露吧。中国人讲究韬光养晦。美国人就不一样，他们就感觉，觉得是自己的权利就一定要去争取那种，不在乎在公众场合。中国人就会觉得特别丢脸。他们应该这方面和中国，东西方文化有很大差异。 [...]

English translation:

GW: I have seen this episode. I think, first, that fat woman scrambles for the washing machine with them. I think they fairly emphasize human rights, emphasize their own rights, if, I think, this incident happened to me, I would think that it's better to make concessions to avoid trouble. Because there are still many washing machines near by, don't dispute with others because of the issue of washing machines, then become the centre of the attention from people around. I think Chinese have strong attitudes of taking a mean course. (Chinese). Do not want to become centre of the attention in the public occasions; do not make a showy display of ability. Chinese devote particular care to keeping a low profile. Americans are different, they think, they, if it's own right then will definitely fight for that, do not care if it's in public occasions. Chinese people will find it very humiliating. In this aspect they should follow China, there's great difference between the western and oriental cultures. [...]

First of all, based on GW's interpretation of Ross and Rachel, GW developed her interpretation of their actions with regard to fighting for the washing machine with the other woman. Then, as the underlined sentences show, GW re-contextualized herself in Rachel's situation and imagined what her reactions would be, as well as the reasons behind those actions. When 'walking' in Rachel's shoes, it would be reasonable to speculate that there was a comparison going on in GW's mind between Rachel and Ross and herself, in terms of their views and attitudes towards the washing-machine-incident. Also the second half of GW's comments indicate that she has a generalized perception of both Chinese and Americans. Where did these ideas come from? For example, did the concept of 'emphasizing human right' merely come from Ross and Rachel's actions in a sitcom, or was the idea from GW's pre-existing knowledge of Americans? Was her concept of Chinese people being keen to 'keep a low profile' only developed by imagining her own behaviour in an imagined scenario? It could be argued that GW's ideas on both groups of people existed prior to the interview, or even viewing the clip for the first time. If this was the case, those ideas automatically played an important role in her making sense of the clip. However, it would be reasonable to speculate that GW's perceptions of both Chinese and Americans were affected, and

probably reinforced, by her sense-making activities, including interpreting the characters and re-contextualizing herself in the fictional setting.

Looking at comments from both SYY and GW, it seems that GW reacted more strongly and had a lot more to talk about than SYY. This is probably partly due to the fact that GW had already watched the whole episode before, whilst SYY only viewed the clip for the first time. Another possible reason is individual differences. Although SYY and GW both re-contextualized themselves in the *same* character's situation, the things which were prominent to each of them were *different*.

I showed a clip, *Prepare for launch*⁵⁶, to WZT, who had not seen the film before. After viewing, she pointed out one thing she had in common with the main character Bridget: seeking for advice from close friends before going out for a date. WZT then continued:

(Q.6.4.3.3)

WZT: [...] 现在的女生不一样了。现在的女生都是，有一句话就是，(如果你)喜欢我就应该喜欢我的全部。不要让我为你改变。(如果)我为你改变是我为你自愿。不要强迫我为你改变。我看她(Bridget)也是很自愿的改变。但是换了我的话，我就是这个样子，你喜欢是这个样子，不喜欢(我)也是这个样子。(如果你)不喜欢(我)就拉倒了。喜欢的话，我要是也很喜欢你的话，我会慢慢的试图稍微改变一下。你比如说你喜欢长头发的，那我就留一下长头发，倒无所谓。但是要那么着，诶呀，把自己的腿的毛给拔的，那个毛，给拔的，天啊，太折磨自己了！我这个人还是比较以自己为中心的。我不行，就算我再怎么喜欢你，我也不至于那样去糟践自己。

English translation:

WZT: [...] Girls are different nowadays. Girls these days are all, there's a sentence, it's, '(if you) like me, like everything about me'. Do not ask me to change for you. (If) I change for you it's because I am willing to change for you. Do not force me to change for you. I think she (Bridget) changes herself voluntarily. But if it were me, this is how I am, I am like this if you like me, and I am still like this even if you don't like (me). Then forget about it if (you) do not like (me). If you like me, and if I like you very much too, I will gradually try to change slightly. For example, you like long hair, then I will grow long hair, it doesn't matter. But if I have to do that, ouch, wax hair off her legs, that hair, wax, my god, torture herself too much! I am quite self-centered. I cannot. No matter how much I like you, I would not go so far as to torment myself.

After first recognizing similarity between Bridget and herself, WZT re-contextualized herself in Bridget's situation and imagined her behaviour and reaction, as the second underlined sentence shows. In doing so, it seems that there was a comparison going on between herself and Bridget, which results WZT seeing differences between herself and Bridget with regard to their attitudes to a relationship. In addition, the words 'girls these days' (现在的女生) used by WZT shown in the

⁵⁶ Prepare for launch: A clip from the British film, *Bridge Jones's Diary* (2001). In the clip, Bridget needs to prepare for an important social occasion at her work, at which Bridget plans to entice Daniel, the man she fancies and hopes to date. Bridget turns to her close friends, Jude, Sharon and Tom, to ask for help. The clip also includes Bridget's preparation in her bedroom, such as choosing which underwear to wear, practicing her introductory speech, etc.

first underlined sentence indicate that WZT has a rather generalized idea of Chinese girls, most probably girls in her age group, and thinks they are more similar to her than to Bridget.

Now, let us look at another example from the same student, WZT. Having watched the clip, *Director*, from the film *Crash* that she had not watched before, WZT said:

(Q.6.4.3.4)

WZT: 他的意思是，那个演员，他说话好像是在尽力掩盖他的身份啊。

Interviewer: 哦！你是说他说话不像黑人？

WZT: 对。然后我马上就想到一个人，Jackson嘛。

Interviewer: 哦！Michael Jackson？

WZT: 整容啊乱七八糟的，想掩盖自己黑人的身份嘛。他那个演员，不是说话不黑，其实就是想把自己的身份给掩盖掉。我觉得这个没什么啊。我觉得，就跟如果是我的话，我的身份，如果别人会歧视我的话，我也会尽力掩盖啊。能怎么着掩饰就怎么掩饰啊。

English translation:

WZT: What he (Fred) meant was, that actor (Jamal), he spoke as if he was trying his best to cover up his identity.

Interviewer: Uh huh! You mean he did not speak like a black person?

WZT: Yes. Then I immediately thought of one person, Jackson.

Interviewer: Oh! Michael Jackson⁵⁷?

WZT: Cosmetics surgery etc, a mess. (Michael Jackson) Wanted to cover up his own black identity. That actor, it's not (he) spoke less black, actually (he) wanted to conceal his own identity. I think there's nothing wrong with it. I think, for example if it were me, my identity, if others discriminate against me, I'd do my best to disguise. Do whatever I can do to hide.

As the underlined sentences indicate, WZT re-contextualized herself in the situation of the discriminated character, Jamal (the black actor), and imagined her own reaction and behaviour. Although my data cannot provide an explanation of why WZT would conceal her identity against people who discriminate her, it can be argued that this re-contextualization sense-making activity played an important role in WZT's interpretation and judgment of Jamal's actions and intentions. At this point, I cannot help but wonder what made WZT think that Jamal was discriminated against in the clip? Was it because Jamal was black, and that made WZT automatically associate the character with the wider black community and their stereotypical status in the society? Or was it because the character that questioned Jamal's accent happened to be a white man, which WZT associated with racial discrimination? It could be either or both. Also, it seems that Jamal's behaviour prompted WZT not only to think of a person in real life, Michael Jackson, but also identified a similarity between those two, which was to cover up their identity. Therefore, it would be reasonable to speculate that, prior to viewing the clip, the idea of 'concealing identity' with regard to race and discrimination most probably already existed in WZT's framework of

⁵⁷ Michael Jackson: Michael Jackson (August 29, 1958 – June 25, 2009), known as the "King of Pop", was one of the most successful and influential musician and singer. Despises his success in his career, his 'changing appearances' drew media publicity, with changes to his nose and to the color of his skin (from black to white)

knowledge and values. These affected her making sense of the fictional characters and real people, and her own decisions regarding her behaviour in a similar situation.

To sum up, the examples in this section have demonstrated that, when making sense of foreign films and TV series, sometimes Chinese college students re-contextualize themselves in fictional settings and imagine their actions and behaviours if they were in the character's shoes. Sense-making activities of this kind are sometimes accompanied by comparison activities, which lead CCSs to see differences and similarities between themselves and the characters.

Several factors influence the process of sense-making activities of this kind, including the CCSs' interpretation of the characters, relevant knowledge of self, Chinese people, and people represented by the characters, as well as personal experience. In addition, whether CCSs are new to the programme as well as whether CCSs watch the whole or part of the show are another two factors which may affect CCSs' response to and making sense of foreign films.

6.4.4 Re-contextualizing Chinese People in General in the Fictional Context

(Q.6.4.4.1)

JT: 如果一个中国男人知道一个女的, 她同时有丈夫有男朋友还想和自己发生一段关系的话, 估计那男的就得把那个女的给杀了, 就得疯了!

English translation:

JT: If a Chinese man knew a woman while she's married and had a boyfriend and still wanted to have a relationship with him, (I) assume that (Chinese) man would kill that woman, would've gone mad!

The comments above are from the text extract of the two female students that I interviewed together. I showed JT and TXH the clip, *Chandler's date*⁵⁸ from American sitcom *Friends*, which they had not seen before.

(Q.6.4.4.2)

JT: 我一开始我觉得那个男的非常镇定, 听说她有丈夫, 而且和他结婚, 他一直问她是不是寡妇啊什么的. 我觉得他非常镇定, 就是他们已经不认为女人这样子有什么问题. 如果一个中国男人知道一个女的, 她同时有丈夫有男朋友还想和自己发生一段关系的话, 估计那男的就得把那个女的给杀了, 就得疯了! 就是我觉得, 一个是, 那个男人非常镇定, 就是女的这样不是什么特别不可原谅的问题. 还有就是, 他们朋友之间什么都在这里说. 不是说这是什么特别大的事情, 他们就是很平常的事情, 和朋友分享, 没有什么问题. 但是就和我们文化不一样的就是, 如果中国人, 一个男人, 很大男子主义嘛, 中国的男人都是这样, 然后就如果他同时脚踏两支船的话, 他会给自己最好的朋友将, 但是他绝对不会讲得很多, 因为他的朋友也会怪他, 就是说你怎么这个样子?

TXH: 对, 你也太没用了。

JT: 脚踏两支船, 一个都解决不了, 什么的, 但是他们之间这些朋友好像也不觉

⁵⁸ Chandler's date: The clip was chosen from American sitcom *Friends* (1996-2006). In the clip, Chandler shares his dating experience with a very beautiful woman, Aurora. Aurora is married and have a boyfriend, meanwhile, wants to maintain sexual relationship with Chandler. Chandler tells his friends that he will keep seeing Aurora. His friends, Monica and Phoebe disapprove, whilst, Ross and Joey support Chandler's decision.

得是什么问题。

English translation:

JT: At the very beginning, I thought that man (Chandler) was very calm, (when he) heard that she (Aurora) had a husband, and got married, he (Chandler) kept asking her whether she's widow or not etc. I think he's very calm (because) he didn't think there's any problem with this woman's behaviour. If a Chinese man knew a woman while she's married and had a boyfriend and still wanted to have a relationship with him, (I) assume that (Chinese) man would kill that woman, would've gone mad! (I) feel that, one is, that guy (Chandler) was very calm, that is to say, that woman's behaviour is not something that cannot be forgiven. Also, among their friends (they) talk about everything here. Not something very big, they (talk about) common things, to share with friends, no problem. But what is different from our culture is that a man, if a Chinese, is very male chauvinist – all Chinese men are like this; if he straddles two boats at the same time, he would tell his best friends, but he would not tell a lot because his friends would criticize him, saying, 'how could you do this?'

TXH: Yah. 'You are too useless'.

JT: Straddling two boats cannot solve either one of them, etc. But it seems that, among these friends, (they) don't think this is a problem.

JT re-contextualized a Chinese man in Chandler's situation and speculated how he would handle things in the same circumstances, such as dating Aurora and sharing with his friends, as well as the reasons for his actions. Although JT said 'one Chinese man', her comment 'all Chinese men are like this' indicates that, most probably, in her mind she was referring to Chinese men in general. In addition, JT took a further step and speculated how this Chinese guy's friends would react. It is interesting that JT and TXH even thought about what the friends would say to him. Such a vivid picture portrayed by JT and THX showed their perception of Chinese men, in particular with regard to issues of views and attitudes towards dating.

It seems that there was a comparison between Chinese men and Chandler, as well as between Chinese friends and Chandler's friends. It is interesting that JT believed Chandler's friends were happy with him going out with a women like Aurora. However, if we look closely at what happens in the clip, actually there were different opinions among Chandler's friends on this issue. Two female friends, Monica and Phoebe, clearly were not happy about it, whilst male friends Ross and Joey were happy for Chandler, because they were pleased with the idea of sex-with-no-responsibility. What made JT interpret Chandler's friends in this way? This may be due to the fact that the show is a comedy, and JT might not have been able to pick up the signals, such as sarcasm and irony, which are culturally specific but help the audience to comprehend the show. Another possible reason is language proficiency, because it was the first time JT watched the clip, and she might not have understood everything that the characters said.

From the discussion between JT and TXH, it would be reasonable to say that JT and TXH influenced each other's interpretation of the clip to some extent. Therefore, it can be argued that

'peer influence' is another aspect which affects students making sense of foreign films and TV series.

Now, let us look at another example from JT when she talked about *Sex and the City*, an American TV series. JT said that the four main female characters are very different from Chinese. I then prompted her:

(Q.6.4.4.3)

Interviewer: 你刚才说和咱们太不一样了。怎么不一样了?

JT: 中国人很含蓄,尤其是东方的话,尤其是中国人特别讲究含蓄,像这种什么欲望啊,性啊,都不会去说的。但是,她们就在一个餐馆里面,4个人围着坐在一起,就在讨论昨天和哪个男生上床,而且有些时候说的激动了,它们四个人讲的很激动,在那里,讲的很大声,拍桌子,然后讲一些特别受不了的那种话。我觉得,如果是中国人,两个人悄悄在家里说都挺不容易的了,还在餐馆里面4个人围着大声的说,我觉得简直是不可能的,对中国人来说是不可能的。

English translation:

Interviewer: You mentioned that they are very different from us. How different?

JT: Chinese are very reserved, especially in the East, especially Chinese particularly stress being reticent; things like desire, sex, (Chinese) would never talk about. But they sit in a restaurant, 4 individuals sit around (the table) together, and discuss sleeping with some guy yesterday, plus, sometimes they talk with excitement, those 4 people talk with a lot of excitement, (sitting) there, talk very loudly, bang the table, and then speak some language that (I) very much cannot stand. I think if it were Chinese, two people would quietly talk (about it) at home at the most; I think it's almost impossible (for those two Chinese) to be sitting in a restaurant and talking about it loudly. It's impossible for Chinese to behave like this.

One of the social routines of these four fictional female friends is sitting in a restaurant or café sharing with each other their thoughts, views and experience of dating. It seems that JT reacted particularly strongly to and had deep impression of this particular aspect of the show. It seems JT tried to put Chinese people into the characters' context. In doing so, there was a comparison going on in JT's mind which resulted in her seeing the differences between the four characters and Chinese people in general.

To summarize, the text extracts in this section have demonstrated that Chinese college students (CCSs) sometimes re-contextualize Chinese people in general, rather than any particular individual, in the fictional character's settings. In doing so, CCSs imagine Chinese people's responses and reactions in the fictional circumstances. Usually, this type of re-contextualization activity is accompanied by comparison between the characters and the Chinese people in general. Findings from the data suggest that the comparison activities usually result in CCSs finding differences between the characters and Chinese people. From a linguistic point of view, the second conditional clauses that are often used indicate re-contextualizing sense-making activities.

Factors, such as CCSs' interpretation and understanding of the characters, as well as existing knowledge and views of the Chinese population in general, play essential roles in the process of this type of sense-making activity.

6.4.5 Summary

The current chapter has identified and illustrated another main category of Chinese college students' (CCSs) sense-making activities, re-contextualizing. These activities broadly fall into four sub-categories.

- **Re-contextualizing the fictional character(s) in a personal context**

CCSs sometimes re-contextualize fictional characters in the CCSs' own personal settings, and imagine their reaction and behaviour.

- **Re-contextualizing the fictional character(s) in a Chinese context**

At times CCSs re-contextualize fictional characters in the general Chinese context, rather than any individual personal settings. As a result, CCSs normally try to visualize how the fictional characters would fit into the Chinese context, as well as how Chinese people in general would react to the characters.

Comparing these two types of sense-making activities, what they share in common is that CCSs seem to move the fictional characters from the film and project them into reality, in particular, into the Chinese context where CCSs belong.

- **Re-contextualizing self in the fictional context**

Every now and then, CCSs re-contextualize themselves in the fictional characters' setting and imagine how they would behave and feel.

- **Re-contextualizing Chinese people in general in the fictional context**

Occasionally, CCSs project Chinese people in general, rather than any particular individual Chinese, into the character's settings.

Looking at the third and final interpretative activities, what they share in common is that CCSs appear to move Chinese people from the Chinese setting and project them into the characters' fictional context. Sometimes CCSs picture themselves, a particular group of Chinese or a general Chinese in the characters' shoes.

The findings suggest that re-contextualization sense-making activities are often accompanied with comparison activities, which usually lead CCSs to seeing differences, and occasionally similarities, between fictional characters and either the CCSs themselves or Chinese people, depending on the type of re-contextualization activities.

Due to the nature of re-contextualization activities, there are three main parties involved. They are the fictional characters, the CCSs themselves, and Chinese people in general. Only occasionally did people represented by the characters appear in the process.

The data suggests the factors which play important role in the process of re-contextualizing activities include knowledge of self, Chinese people and China, the CCSs' life experience, as well as interpretation of characters and their surroundings. In addition, whether or not CCSs have seen the show before, as well as whether they watch part or the whole programme, appear to be another two elements which affect CCSs making-sense of foreign films and TV series. When CCSs watch a show for the first time, language and culturally specific signals in the programme, such as humour, might be difficult for the CCSs to comprehend.

6.5 Perceiving as Realistic

“Tom Clancy once said ‘the difference between fiction and reality is fiction has to make sense’. My data convinced me that the relationship between fiction and reality is far more complex than that.” (My memo on 11th December 2009)

Having presented findings identifying sense-making activities falling into the main categories ‘comprehending plot’, ‘comparing: identifying differences’, ‘comparing: identifying similarities’, and ‘re-contextualizing’ from the empirical data, the current section identifies and illustrates a final category of sense-making activities, titled ‘perceiving as realistic’. The concept of something being ‘realistic’ is a complex one. A film might be perceived as unrealistic if a hero shoots a gun too many times without reloading, or is able to fight lots of people at once. However, that is not the sense of realism which is of interest here. In the current study the interest is in whether the film is perceived as realistic in the sense of being a true reflection of life and culture in the foreign country. With the focus of current study, foreign country refers to both the U.K. and the U.S.A.

The issue of ‘perceiving foreign films as realistic reflections of foreign countries’ was briefly touched upon in chapter five. As mentioned previously, in the Chinese context the term *film* has been used to refer to both films and TV series. As illustrated by text extracts Q.5.2.1, Q.5.2.3 and Q.5.2.4 in chapter five, some students perceive foreign films as realistic representation of foreign countries and some students perceive foreign films as, at least to some extent, reflecting the reality of foreign countries and cultures. Judging criteria fall into three categories, genre of the

films, the type of film (i.e. Hollywood, blockbuster) and the maker of the film (i.e. made by native English speakers rather than Chinese).

This category of sense-making activities is particularly important in the intercultural education context. When CCSs watch films from different cultures, specifically from the U.K. and U.S.A., there is significant scope for misinterpretation, such as perceiving the content of the foreign film as reflecting reality when this might not have been the intention of the director. Therefore, this section will have useful implications for teachers who are keen on using foreign films in their ELT classroom.

6.5.1 Mirror of Reality

(Q.6.5.1.1)

GH: 电影很直接, 然后也比较真实.

English translation:

GH: Films are very direct, and also they are quite realistic.

Chinese college students (CCSs) do not watch foreign films with a blank mind. Rather, they watch films with their existing perceptions and expectations of foreign films and foreign countries/cultures, and these play an important role in the process of making sense of the films. Do CCSs consider foreign films to be merely a form of entertainment, or a mirror of reality, or more? We shall find out.

(Q.6.5.1.2)

JT: 电影是一种比较大众, 而且是比较通俗的一种形式。[...] 就是如果是靠中国人, 中国节目来看国外的文化的话, 可能会美化, 或者是有些不好的地方会丑化, 好的地方会过于美化。

English translation:

JT: Film is comparatively popular, and also it's relatively common. [...] If I rely on Chinese people and view foreign culture through Chinese programs, it'd be embellished, or some bad aspects would be exaggerated and some good aspects would be over embellished.

First of all, JT, a female Chinese college student, believed foreign films *can* reflect reality, whereas films made in China about foreign people and cultures would provide a distorted view. This means, JT may see the content of foreign films as an accurate representation of how things are and what is going on in the films' countries of origin, such as the U.S.A. and the U.K. It can be speculated that JT seeing foreign films as mirror of reality might make her a vulnerable viewer, in the sense that she might take the films at face value without being critical. Hence, her perceptions of and attitudes towards foreign people and cultures could be affected.

Other findings suggest that JT is not the only CCS who holds such views.

(Q.6.5.1.3)

GH: 电影很直接, 然后也比较真实。毕竟是外国人直接拍的, 比较真实。再一个也很快, 看报纸的话, 很多单词也不认识。所以很困难。

Interviewer: 你说的很快是什么意思?

GH: 很快就是, 它有一些文化的很深层的东西, 可以通过他的动作和语言表达出来。但是看报纸的话, 比较困难。

Interviewer: 为什么困难?

GH: 因为读英文报纸, 毕竟不是那个专业的学生, 所以要费一些时间。而且看那些电影的话, 因为它毕竟是一个完整的剧情, 而且是自己喜欢的题材, 所以比较有兴趣, 所以能够看下去, 然后在那个过程中接受他们的东西。

Interviewer: 你说最直接, 最快的, 我还是有点不明白。

GH: 直接就是, 你要是读什么名著的话, 一本读完了, 你不一定还有什么印象, 你再读读很多才能通过他们的, 吃饭是什么样子, 问候是什么样子, 慢慢的才能总结出他们的文化。你要是看电影的话, 他就是这样子, 动作就是这样子, 然后你就看到他们怎么怎么礼貌, 怎么怎么问候这样子。就快嘛, 那就不用说了, 快就是, 他那边有了, 我看电影, 他是最新的嘛, 2006, 2007年, 这样子很快。

Interviewer: 那你说的直接, 就是有声有图象...?

GH: 对, 就是比较有意思, 你看名著我我看了就忘掉了。

Interviewer: 那报纸呢?

GH: 都是新闻, 但是也有文化的。那种不太真实, 有色眼睛那样子看的话不太真实。

Interviewer: 你是说报纸通过另外一个人的报道?

GH: 对。

Interviewer: 那电影呢? 电影不是也是个人导演出来的?

GH: 但是它不是中国人导演的, 他是当地人导演的。我拍中国的肯定是按照我的角度来对吧?

Interviewer: 你说的报纸是不是中国人报道?

GH: 环球时报, 中国记者写的也有, 但大部分文章是翻译过来的, 不是自己写的, 他选的, 就是从其他报纸, 选的, 编辑报纸, 这个内容是外国人看中国, 是直接翻译过来的, 但是那些对中国不好的东西他是不会翻译过来的, 这种东西你是看不到的。

Interviewer: 那你说外国人拍外国电影?

GH: 可信度还是高一些。比较反映现实。

English translation:

GH: Films are very direct, and it's quite realistic. After all, they are directly made by foreigners, pretty realistic. In addition, very fast. If I read newspaper, I do not understand many words. Therefore, it's hard.

Interviewer: What did you mean when you said 'fast'?

GH: Fast means, there's deep cultural things, which can be expressed by their actions and language. But if read newspaper, it's quite hard.

Interviewer: Why hard?

GH: Because reading English newspaper, after all, (I'm) not English major, therefore, it will take some time. Plus, watching films, because, after all, a complete story, plus, it's my favourite subjects, therefore very interested, can keep watching it, and learn about their stuff during the process.

Interviewer: You said straightforward, fast, I still do not quite understand.

GH: Straightforward means, if you read classic novels, you probably won't have any impression after reading one book, you read again and a lot, then can through their, what it is like to have meals, what it is like to greet, can slowly summarize their culture. If you watch films, s/he is like this, actions is like this, then you can see how

they are being polite, how to greet. It's fact, it goes without saying that, fast means, they have them over there, I watch films, it's the latest, 2006, 2007, it's very quick in this way.

Interviewer: What you said direct, it means it has sound and picture ...?

G: Yes, it's very interesting. You see, reading classics, I'll forget after I read it.

Interviewer: What about newspaper?

GH: All news, but there's also things related with culture. It's not very realistic, it's not realistic if look at things through coloured spectacles.

Interviewer: Did you mean newspaper is reported by another person?

GH: Yes.

Interviewer: What about films? Aren't films directed by director?

GH: But they are not directed by Chinese director. It's directed by native director. If I film China, I definitely do it from my own perspective.

Interviewer: Is the newspaper reported by Chinese?

GH: *Global Times*, there are articles written by Chinese journalists, most of the articles are translated (from English to Chinese), but written by themselves. They choose, from other newspapers, select, edit newspaper. This content is how foreigners look at China, they are translated directly, but the things which are not good for China are not translated. You can find these things.

Interviewer: What about the foreign films made by foreigners?

GH: Reliability is higher. Reflect reality more.

GH, a male CCS, also clearly perceived foreign films as a reliable representation of reality.

- **Concept of authority**

Comparing JT and GH, it seems that both of them share a similar concept of *authority*. In other words, in terms of reflecting reality of foreign countries, JT and GH believe that foreign films made by people from films' countries of origin hold authority over films made by others, such as films made by Chinese about foreign countries. This is culturally specific, and shows a perception by students like GH that the media in China is controlled by the government and doesn't reflect reality anyway. Students from a different cultural background may have different ideas. For example, U.K. students may consider films about China made by U.K. film-makers to be more realistic than films about China made by Chinese film-makers because U.K. students might assume that Chinese film makers mainly want the audiences to see the best in the country.

(Q.6.5.1.4)

WZT: 像那个 Titanic 号的片段, 它那个就是, 有一个问题, 就是你看, 为什么人家国家能够做到的, 妇女的儿童先上那个, 我们国家做不到, 它这个就是, 感觉就是有一种, 就是看完片子以后可以思考一下, 就有一种深思那种感觉, 就是发人...什么引人...啊, 引人入胜啊, 事后就是什么, 深思啊, 这样的, 引起人的那个什么, 考虑啊, 就那样的, 它那个方面。还有就是最后这个白人黑人种族这个问题, 现在种族问题不是也闹的挺凶的嘛, 这个也是个社会问题嘛。我觉得, 电影吧, 它这个做为一个, 平常人都会看嘛, 这个电影, 我觉得从电影里也能了解到一些社会问题(哦), 像这些影片都是很有价值的, 它是经典嘛, 那这方面定是有原因的, 像那个同性恋的那个问题, 你说, 现在基本上社会上出现什么问题他就能拍出来什么样的电影。[...]

English translation:

WZT: Like that clip in *Titanic*, that is, there's a problem, you see, why people in their country can do that, the one about women and children first, our country cannot, this is, it feels there is a kind of, can think about it after viewing this film, have a feeling of thinking deeply, it's like...give people food for thought ..., interesting and absorbing, after viewing, think over, like this, made people, consider, like that, that aspect. And there is a problem of white and black race at the end. Nowadays, the racial issues cause lots of rumpus, this is also social problem. I think films, as, ordinary people all watch it, films, I think can learn some social issues from films. For example these films are all valuable because they are classic. For example that issue of homosexual, you see, nowadays whatever problems exist in the society we can make whatever kind of films. [...]

WZT believed that foreign films on the one hand are products of the society they came from; on the other hand, realistically reflect aspects of certain social issues. WZT's views seem to have developed from her past viewing experience. For example, having viewed clips such as *Women and children first*, *Shop for gun* and *Prepare for launch*, it seems that the similarity between the clip content and the situations and people WZT experienced in real life made WZT perceive the content of the clips as realistic.

Looking at the above three examples from JT, GH and WZT, all of them seem to share similar high confidence in perceiving that foreign films mirror foreign reality, although the reasons behind their views are different. However, other findings suggest that such views are not universal among CCSs.

(Q.6.5.1.5)

GW: 电影也不是完全能够真实的反映一个国家, 就是你, 对美国可能不了解, 但是对自己国家了解, 你看中国一些影片, 难道就彻底的反映中国的国情吗? 所以我觉得有时候放的一些东西, 不一定就是真实再现了一个国家的风土人情吧。我主要乐意看书什么的。所以我就想以后要亲眼体会以下。

English translation:

GW: films cannot fully realistically reflect a country, it's like, perhaps you do not know much about the U.S.A., but you do know a lot about own country. When you watch some Chinese films, could it really be said that they can completely reflect the conditions of China? Therefore I think sometimes the films I have watched do not necessarily mirror a country's customs and practices. I am mainly satisfied by reading about these things. However, I also want to personally experience them.

Unlike previous three CCSs, GW did not perceive foreign films as an accurate representation of reality. Instead she believed that there is a gap between foreign films and the reality of foreign countries. Another two female CCSs share similar views with GW.

(Q.6.5.1.6)

Interviewer: 你在看美/英剧, 在看的同时, 除了想欣赏故事情节和提高英语目的之外, 你们有没有确实是抱着了解一些当地风土人情的这种目的去看的?

CM: 没有

LM: 没有, 因为电影跟实际生活有差距.有些可能不会去了解.

CM: 对对对.

LM: 我只是为了...很大一部分原因是为了娱乐。

CM:对, 消遣。

LM: 然后顺便多听听英语, 英语很重要很重要嘛

English translation:

Interviewer: You watch American/British films. Meanwhile, except aiming to appreciate the plot and improving your English, have you wanted to learn about things?

CM: No.

LM: No, because there's distance between films and reality. Some things perhaps cannot be learned.

CM: Yah, yah.

LM: We only want to, the major reason is for entertainment purposes.

CM: True, for passing time.

LM: Then, at the same time, try to listen to English. English is very important.

Like GW, CM and LM do not perceive foreign films as mirror of reality. For CM and LM, the two main purposes for viewing foreign films are entertainment and improving English. These views appear to be very common among CCSs.

(Q.6.5.1.7)

HWY: 虽然电影肯定是, 因为是人写的, 肯定是有一点和事实不符, 但是电影人还是希望能够把真实的现实社会展现给我们观众看的。所以他应该会描写一下当下大家比较关注的问题。不管是关于人的心理问题, 人性的脆弱也好, 或者是社会问题, 都会从电影里面展现给我们看, 从这个角度我们能了解不少。[...] 因为电影人嘛, 就是从电影人的角度去感受美国那种, 就是他们为什么要选择这个题材? 不管是他们出于商业角度还是, 那你就会感觉到, 啊, 原来美国人对商业这个东西, 对, 恩, 他们在电影方面持的是这样一个观点。那么就可以从这个角度来考虑美国人在这个文化, 他们对文化的态度, 不是说从电影本身里面的故事去考虑。

English translation:

HWY: Although films, because they are written by people, definitely do not correspond entirely with the reality, but these people still wish to show the true realities of society to our audiences. Therefore, they should be describing issues which concern everyone. No matter whether it's about people's psychological issues, weakness of mankind, or social problems, all will be presented to us. From this perspective, we can learn a lot. [...] Because people who make films, they experience the U.S.A. through their own perspective, so why do they chose this subject? No matter whether they have a business perspective or other perspective, then you can see that, "ah, it turns out Americans see business in this way, yes, erm, in films they hold this particular view". Then we can consider American culture from this angle, their attitudes towards their culture, rather than to consider the stories within the films.

Unlike GH and JT, who perceive foreign films as mirroring the reality of foreign countries, HWY's view is more critical. However, although HWY recognises the gap between foreign films and the reality, she seems to assume that the purpose of films makers is to represent aspects of reality to the audiences. However, this assumption is a bit over-generalized, because film makers may have other intentions. It could be speculated that, having this perception in mind, HWY is more likely to

be influenced by the foreign films with regard to understanding of and attitudes to foreign countries.

Now, let's look at another example from a group-interview of four CCSs.

(Q.6.5.1.8)

S4: [...] 我感觉它是不是跟真正的美国社会是贴近的，因为从中国的电影我就能看出来，它往往带有一些艺术化的东西，他是不是真实的美国社会的？美国的真实社会是不是每个人都象 *Forrest* 那样都能得到社会的爱，他又那么的爱社会？是不是就象 *Shawshank Redemption* 里面那样每个人受冤枉，然后在监狱里那么黑暗造成那种暴力呢？是不是整个社会的场景都是那样？它仅仅是把其中的某个点，经过艺术家的演绎，演绎出过就是为了好看，吸引你，能够印发你心理的东西，但是他未必就是真正很平凡很平淡的生活。

English translation:

S4: [...] I feel that it's not close to the true American society, because I can see this from Chinese films. They often have some artistic things. Is it real American society? Can every American be loved by the society in the same way as *Forrest*? And love the society that much? Is everyone treated unjustly like in the *Shawshank Redemption*, and when in prison does the darkness make everyone that violent? Is the whole society like that? It's merely one aspect, through artist's inference and interpretation, the purpose is to look good and attract you, to stimulate your inner thoughts, but it's not necessarily the real, very ordinary very prosaic life.

What makes S4 stands out among other CCSs is that he holds a comparatively sophisticated view of the extent to which foreign films reflect reality. Instead of seeing foreign films as completely realistic, S4 not only recognized the nature of foreign films as product of films makers for various entertainment purposes, but also was able to distance himself and look at foreign films more critically.

After hearing S4's comment, I continued asking the four of them what they thought about the clips they watched during the interview. They said:

(Q.6.5.1.9)

S4: 我感觉他们是经过演绎的。美国人也并不是每天都在象 *Forrest* 那样用他笨笨的头脑在思索。他也要吃饭睡觉，都有嘛。我感觉他们能够体现一种生活的东西，但是体现的并不是很完全，或者是他体现的比真正生活高那么一点点的东西。他的经过提炼，凝结出来的。

S1: 价值就是很小的一部分，都是商业片吧，纯属娱乐，你看电影就是休闲娱乐放松马，你哪会去深层次的去考虑他的内在联系。除非你特别特别喜欢，重复的看，比如 *Titanic*，比较煽情，但是会有很大的触动，但是大多出都是娱乐方面的。

S2: 比较同意。艺术嘛，就像他说的那种，它不是真实的，他是从生活中截取的某一方面去突出的表现他。就是说你从一个电影里面你可能会体会到一种文化，但是这种文化只是一个片面的东西，就是你不能很深刻的或者全面的去了解它，也可能你从这里学到的，看到的，理解到的，就是偏差了，就是不是很准确。她说的记录片挺好的，如果是记录片可能会更全面更真实一点吧。

English translation:

S4: I think they (FFs) have been rationalised. Americans definitely do not behave

every day the way Forrest does, thinking by using his thick head. They also need to eat and sleep, and all that. I think they (FFs) can embody some things from real life, but not fully, or what they do embody is bigger than life. It's been refined and condensed.

S1: They are all commercial films, purely for entertainment. You watch films because you want to have fun and relax. You don't think deeply about the things connected within (the film). Unless you like it particularly much and watch it repeatedly, such as Titanic, very sensational, there you will be greatly touched, but most of it is for entertainment.

S2: Quite agree. Art, well, like what he said, it's not real, it's the part of life from which has been cut out and highlighted. It means you perhaps can learn a kind of culture from films, but this type of culture is merely one-sided, it means you cannot understand it very deeply and fully. Probably what you learn, see and understand is not very deviated, but not quite accurate. She said documentary is good. If it's documentary, probably they are more realistic.

All above three CCSs seems to share the similar view that foreign films, as entertainment products, are products developed from life but bigger than life. With regard to the group-phenomenon, it is clear that S4's view not only facilitated but also set the tone for the rest of the discussion. It can be speculated the views of the other two CCSs were, at least to some extent, affected by S4.

During the course of the interviews, it seemed these young adults sometimes wanted to impress each other, or myself, by expressing sophisticated views. This was particularly evident in the group interviews. The CCSs are in the same age-group and with similar educational background, and when they are sitting together and expressing their opinions, naturally there are social influences at work. This was particularly evident when above discussion took place. I noticed during this group-interview that S4 (the boy) seemed to be trying hard to impress the girls (particularly S2).

The above examples illustrate that, in terms of the extent to which foreign films reflect the reality of the countries of the film's origin, CCSs hold varying views. Findings from the data suggest three types of CCSs, *believers*, *doubters* and *sceptics*. *Believers* (i.e. GH Q.6.5.1.3; JT Q.6.5.1.2) tend to believe that foreign films mirror the reality of society, and have high confidence in learning about the origin countries via foreign films. In other words, believers perceive the content of foreign films to be an accurate representation of how things are and what is going on in films' countries of origin. *Sceptics* (i.e. GW Q.6.5.1.5; LM and CM Q.6.5.1.6), instead of seeing foreign films in a superficial way, tend to see foreign films as entertainment product, created by film makers who distance the foreign films from actual reality for artistic or entertainment purposes. They have very low confidence in learning anything from the foreign films about the people and culture represented by foreign films. *Doubters* (i.e. HWY Q.6.5.1.7) are in between *believers* and *sceptics*. They tend to believe that, although foreign films do not fully represent whole picture of the reality, *some things* within foreign films *do* reflect the reality, because foreign films are part of the society.

They reason that because Chinese films portray some reality but are not entirely realistic, foreign films are the same. It is worth pointing out that the above three labels are used to describe the interviewees' identities in the interviews. This is not an attempt to label any individual permanently.

Now, moving past CCSs' *general* views on foreign, let us find out what they say about specific *individual* foreign films.

6.5.2 Perceiving as Realistic: General to Specific

(Q.6.5.2.1)

Interviewer: 你看过 *Friends*, 能说说吗?

DC: 因为它是情景喜剧, 我觉得它就是对美国的文化生活, 尤其是他们是处与中层阶级, 就是对那个阶级的生活, 我觉得有更多深入的了解。因为它每一集比较短, [...], 而 *Friends* 持续了 10 年, 而且它几乎就是超越不了的经典了。它已经囊括了 10 年美国中产阶级, 他们的生活事业, 感情, 家庭, 各个方面的各个问题, 就已经全囊括进去了。它就是特别贴近生活 [...]

English translation:

Interviewer: Having watched *Friends*, could you please talk about it?

DC: Because it is a situation-comedy, I think it includes life in the U.S.A., especially the life of those who are middle-class (people). I think I have a more in-depth understanding of the life of that class. Because each episode is very short, [...] plus it lasted ten years, and it's almost a classic that can never be overtaken. It includes ten years of the American middle-classes, their life and career, love, family, all sorts of problems in all aspects, all (have been) included in (*Friends*). It's very close to life. [...]

In this quote a female student, DC, talks about one of her favourite shows, *Friends*. For DC, *Friends* is realistic. Given DC's passionate comment about how much she had learned from *Friends* and how classic and realistic the show was, it can be speculated *Friends* has had a significant impact on DC's perception of Americans and their country. However, DC did recognize *Friends* as a sit-com, which is well-known to be a genre which tends to exaggerate reality. Nevertheless, it seems that knowledge of the genre of the show did not deter her from perceiving *Friends* as realistic. One reason might be, as the underlined sentence shows, that DC recognizes lots of similarity between what happened in *Friends* and her own experience, or her existing knowledge about Americans. In the case of DC, the similarity between fantasy and reality overpowered the awareness of the genre. As a result, similarity between fiction and reality leads to the viewer seeing fiction as realistic. Therefore, it can be argued that one of the variables which leads to CCSs seeing foreign films as realistic is *closeness to life*. Here is another example.

(Q.6.5.2.2)

GW: 我觉得 *Growing Pains*, 小鬼当家, 也挺逗乐的。我觉得 *Growing Pains* 挺贴近生活的, 感觉特别真实。那些事就像发生在自己身边一样。然后 *Princess Diary* 灰姑娘变公主, 的确很少, 而且也有童话的意味在里面。但是像 *Growing Pains*, 还有 *Friends*, 就真的是生活中每天都有这样的事情发生。小的事情都能体现出来。

English translation:

GW: I think *Growing Pains* and *Home Alone* are quite funny. I think *Growing Pains* is fairly close to life, it feels particularly realistic. Those things are like (things that) happen around me. And *Princess Diaries*, it's about Cinderella becoming a princess, this rarely happens, it includes a bit of fairy tale. But, like *Growing Pains* and *Friends*, it's really like the sort of things that would happen in everyday life. Even small things can be reflected.

The comparison between *Princess Diaries* with *Growing Pains*, *Home Alone* and *Friends*, further illustrates the important role of this variable, *close to life*.

Two female CCSs talk about *Prison Break*.

(Q.6.5.2.3)

JT: 情节好...

TXH: 对对对。

JT: 然后 *Scofield* 很帅...

TXH: 我觉得他很强啊, 计划什么的...

JT: 天才。首先情节口人心选, 里面 ...但是 *Prison break* 不够生活化...

TXH: 肯定不会发生这种事情, 生活中。

JT: 而且, 他越拍越离谱。第一寄比较好, 后来越排越离谱, 我就不看了。

English translation:

JT: Good plot.

TXH: Yah, yah.

JT: And *Scofield* is very handsome.

TXH: I think he's so awesome, makes plans etc....

JT: Genius! First of all, the plot is enthralling ... but *Prison Break* is not lifelike enough.

TXH: This kind of things definitely can never happen in real life.

JT: And, it's becoming farther and farther away from what is normal. The first season is better but it became more and more outrageous later. Then I stopped watching it.

Again, the factor *close to life* strongly affects the above two CCSs' judgment on *Prison Break*, which is perceived as unrealistic. Also, in the case of JT, as the underlined sentences show, her judgment of the show being unrealistic had a negative effect on her interest and motivation to continue viewing the program. Teachers should keep this in mind when they want to use foreign films as aid to enhance CCSs' motivation in the class. This issue will be further addressed in the discussion chapter.

In terms of the CCSs' comments on individual foreign films, it seems that the above two CCSs are not the only ones who perceive *Prison Break*⁵⁹ as unrealistic. CJY shared the similar opinion with regard to the show.

(Q.6.5.2.4)

CJY: 我都看了。在这之前我基本没看过欧美的连续剧。这主要还是因为情节上

⁵⁹ *Prison Break* (2005-2009): Due to a political conspiracy an innocent man is sent to death row and his only hope is his brother, who makes it his mission to deliberately get himself sent to the same prison in order to break the both of them out from the inside out (IMDB)

的原因吸引我吧。就是情节，悬念非常多。[...]可能应该是夸张的。

Interviewer: 你为什么会觉得他是夸张的呢？

CJY: 觉得那样的话太恐怖了，只是知觉上觉得应该没有那么恐怖吧。我觉得他制度上应该有预防这种事情发生的。政府完全被公司操控，应该没有那么严重。我觉得 *Prison Break* 那个情况，简直太乱了，监狱里面，随便警察跟，当时 *Shawshank Redemption* 那里面和它挺相象的，警察和囚犯有一些很多的交流，很多的，比如说囚犯帮警察干点什么事，她就有一些好处什么的，也挺象的。但是它里面要真的是那么乱，她确实太乱了，我觉得，就是随便找人搞把刀子就可以随便杀人，当然这个还要受惩罚，受乘法是肯定的。 [...]

English translation:?

CJY: I watched all of it. I had never watched American or European dramas before this. It's mainly because of the plot, which attracts me a lot. [...] I think it's probably exaggerated.

Interviewer: What made you think it's exaggerated?

CJY: I think that'd be too scary if that's true. My intuition tells me that real life shouldn't be that scary. I think they should have a system to prevent things like this kind happening. Government is completely controlled by company. It shouldn't be that horrible. I think *Prison Break*, it's too complicated, in the prison, casually with policeman, at the time, *Shawshank Redemption* has something similar to that. There's a lot of communication between policemen and prisoners, pretty much. For example, the prisoners can benefit by helping the police. But if it's truly that messy, it's indeed too complicated, I think, find a knife and then kill a man without any concern, of course this will be punished, that's for sure. [...]

Unlike *Prison Break*, which was perceived by many CCSs as unrealistic, *Forrest Gump* received quite positive comments. When asked to recommend foreign films which can help CCSs learn more about the U.S.A. and U.K., among all the foreign films recommended by the CCSs, *Forrest Gump* appeared to be the most popular.

(Q.6.5.2.5)

PP: 我觉得 *Forrest Gump* 里面就是什么都有了。水门事件，还有刺杀总统，越南战争。什么都有了。高一的时候就看过了，那个时候老师就是为了让了解文化。

English translation:

PP: I think *Forrest Gump* includes everything: the Watergate Scandal, the assassination of the president, the Vietnam War – it has everything. I watched it in my first year of high school. At that time our teacher recommended that we watch it (*Forrest Gump*) in order to know more about (American) culture.

Forrest Gump portrays the life of a low-intelligence man from his childhood to his late life. The film includes a lot of historical moments and events over large period of time which are well-known among CCSs. It seems that CCSs perceive the show as realistic when the content of the film matches their existing knowledge about the target countries.

(Q.6.5.2.6)

JT: 首先，Tom Hanks 的演技很好。就把一个很善良，很单纯的人，很真实的展现在我们面前。然后他还展现了...让我们相信人性是有善的一面的。

English translation:

JT: First, Tom Hanks has great acting skills. He realistically represented a very

kindhearted, innocent person in front of us. Then he showed ..., let us believe, there's good in human nature.

The fact that JT was aware the character, Forrest, was fictional, did not affect JT's belief in the realistic aspect of the character. It seems to me that JT's judgment on the quality of actor's performance plays an important role. In short, good and convincing acting leads JT to perceive the character as realistic. JT was not the only case. The British actress Helen Mirren's acting was so convincing that S4 believed that he learned something about the Queen of the U.K. from the film *The Queen*.

(Q.6.5.2.7)

Interviewer: 哪一部电影让你对英国有了解?

S4: 应该是女王吧。[...] 那个女王, 觉得, 那个演员把她, 她女王比较, 坚韧的一面表达出来了。

English translation

Interviewer: Which film helped you learn about the U.K.?

S4: Should be *The Queen*. [...]. That queen, I feel, that actress delivered the strong aspects of the personality of *The Queen*.

In addition to *acting quality*, some CCSs seem to value award-winning foreign films as more realistic.

(Q.6.5.2.8)

CM: 有一些电影是很反映现实的嘛。就比方说去年的 *Crash*, 好像是比较反映现实。我们看的有一些还是比较那个 ...

LM: Hollywood.

CM: 好来屋大片不是很反映现实。比如, *Ocean's eleven; Parots of Carobean*。那种根本和现实生活没有任何关系。

*Interviewer: 你看过 *Crash* 吗?*

CM&LM: 我们两个没看。

R: 那你为什么觉得反映现实?

LM: 我当时看奥斯卡扮颁奖典礼听他们说的 ... 他们说那个很好, 但是一直没有去看 .[...]

*Interviewer: 那 *Ocean's Eleven* 为什么不现实?*

CM: 因为太离谱了...

LM: 身边不可能发生这种事.

CM: 对。

English translation:

CM: Some of the films reflect reality very much. For example, last year's *Crash* seems to reflect reality. Some (of the films) that we have watched are relatively ...

LM: Hollywood (films)...

CM: Hollywood blockbusters cannot reflect reality. For example, *Ocean's Eleven, Pirates of Caribbean*. That kind (of films) has completely nothing to do with real life.

*Interviewer: Have you watched *Crash*?*

CM&LM: Neither of us has watched it before.

Interviewer: Why do you think it reflects reality?

LM: At that time I watched the Oscar Award Ceremony, I heard from them ... they said that (film) was very good, but I haven't watched ... [...]

*Interviewer: Why is *Ocean's Eleven* not realistic?*

CM: Because it's too far away from what is normal...

LM: This kind of thing is impossible to happen around us.

CM: Yah.

For CM and LM, there are two factors affect their judgment on whether or not a foreign film is realistic. One is *close to life* which has already been discussed previously. The other one is *award-winning*. They both seem to value the award-winning-film so much that they believed *Crash* is realistic even though they had not seen it before, simply because the film won an award. In addition, what is interesting is that CM and LM, in the first section of this chapter, both viewed foreign films as *not* being realistic in general, due to being an entertainment product. However, it seems that their general view of foreign films changed when it came to individual foreign films. One variable behind this change might be *award-winning*. CM and LM are not the only CCSs think in this way.

(Q.6.5.2.9)

GH: 比如说美国那种西部牛仔的话, 你可以选择什么 *Brokeback mountain*。这个片子虽然有争议但是能够反映西部牛在那种生活是不是? 虽然他是同性恋那样子吧, 但是它是能反映现实的, 要不然它怎么能拿奖的。

Interviewer: (笑) 拿奖的就是好的?

GH: 那也不一定, 但是它一定有它拿奖的理由。

English translation:

GH: For example (if wanting to know about) American western cowboys, you could choose, for example, *Brokeback Mountain*. Although this film is a bit controversial it can reflect (American) western cowboys' life, doesn't it? Although they are gays, it can still reflect reality. Otherwise how come it won the award?

Interviewer: (laugh⁶⁰) it's good as long as it's award-winning (film)?

GH: Not necessarily. But there must be reasons behind its winning the award.

Chinese college students seem to particularly value authority. For example, although LM and CM had not watched the film before, they perceived *Crash* as realistic because it is award-winning films. The student GH has a firm belief that the film *Brokeback Mountain* can reflect reality because it has won an award. In addition, as discussed previously, native English speakers have been perceived as an authority on America/U.K., and the films made by native speakers of foreign country are perceived as realistic by some students for this reason (Q.6.1.5.3).

Another variable which affects CCSs perception of whether or not a foreign film is realistic is *film-reviews*.

(Q.6.5.2.10)

HWY: 这个, 因为我看过一些影评, 它比较针对当下的美国问题吧, 可能这个现实性会比较大一点。所以我觉得显示意义会比较大, 这个反映的问题应该会比较真实一点。

English translation:

HWY: This (film), because I have read some film reviews (that said) it (*Crash*) is

⁶⁰ When analysing the data, I was a little surprised by my reaction towards GH's comments.

specifically about current problems in the U.S.A. Probably this (Crash) is more realistic. Therefore, I think (Crash) can reflect reality relatively more. The problems reflected by this film should be relatively more realistic.

In addition to *film reviews*, *rearranged-from-a-true-story* appeared to be another form of authority.

(Q.6.5.2.11)

S2:就是印象比较深的就是那部永不妥协。而且我觉得应该比较反映现实吧。就是关于那个环境，因为它是根据真实事件改编的。

English translation

S2: One film that I have deep impression of is *Erin Brockovich*⁶¹. Plus, I think this film should reflect reality relatively more. It's about the environment. Because it's adapted from a true event.

Here is another example. When asked to recommend any films which helped him learn anything about the U.K., S4 said:

(Q.6.5.2.12)

S4 应该是 *The Queen* 吧。因为那里面也有讲到 Diana 王妃死，对王室，对英国皇室的影响。还有，应该是还算比较写实一点吧，所以，应该是，让我们最多了解的应该就是英国皇室，就是尤其是 Diana 王妃死的那一段时期。那个女王，觉得，应该把她，她女王比较，坚韧的一面表达出来了。

English translation:

S4: Should be *The Queen*. Because it mentioned the death of Princess Diana, and (it's) influence on the royal family, the British royal family. Plus, it should be relatively realistic. Therefore, it should be that what (it) helps us learn the most about is the British royal family, especially in that period of time when Princess Dianna died. That queen, I think, she (the actress) delivered the strong aspect of the personality of the Queen.

A female Chinese college student, LAQ talked about the film *Babel*⁶².

(Q.6.5.2.13)

LAQ: 里面我觉得女主角，我觉得她那个女的被射中以后，然后有 2 个情节特别能反映现在现实的一些东西。

Interviewer: 比如说？

LAQ: 一个是，当时在沙漠里面，没有什么东西，Peter 让一车人等他们，但是那些人就是为了他们自己的利益，就是觉得如果等下去的话他们自己就是利益会得到侵害，所以就是仍下他们两个，那一车人开车走了... 因为那些人觉得他们两个是累赘... 救援人员也不到，那些人等的不耐烦了... 而且 Peter 一直和他们说，但是他们还是走了。[...] 还有一个就是，那个女的或救后... 当时，有个黑人为他们提供住宿... 还找人帮哪个女的疗伤，最后 Peter 从钱夹里拿出来一叠钱给那个难的，那个男的说做了这一切不是为了钱，他单纯只是想帮助他，而不是

⁶¹ Erin Brockovich (2000): An unemployed single mother becomes a legal assistant and almost single-handedly brings down a California power company accused of polluting a city's water supply. (IMDB)

⁶² Babel (2006): Tragedy strikes a married couple on vacation in the Moroccan desert, touching off an interlocking story involving four different families (IMDB). The couple LAQ was talking about is Peter (Brad Pitt) and his wife Cate (Susan Blancett) went to Moroccan for a vacation to try to fix their marriage. Cate was accidently shot by two boys who were tried out their new rifle. The rest of the story is about how the local people in the village helped Cate while Cate and Peter were waiting for ambulance.

想到说这个白人会给我多少钱。[...]我觉得这反映出,有的人觉得别人帮我是有目的的,但是有的时候别人有可能只是看到你有困难,是真心想帮你,并没有什么其他的企图。

English translation:

LAQ: I think that the leading lady, I think after she was shot, there were two scenes that particularly reflect something in reality.

Interviewer: For example?

LAQ: One (scene) is: at that time in the desert there wasn't anything; Peter asked the passengers in the coach to wait for them, but they only cared about their own benefit and thought that if they kept waiting their own benefits would be infringed. Therefore, (they) abandoned both of them. All the passengers in the coach left ... because they thought that they (Peter and injured wife) were a burden ... the ambulance corps hadn't arrived either, those people couldn't wait any longer ... Although Peter kept asking them to wait, they still left. [...] Another (scene) is of that woman after being rescued ... at that time, there was a black man who offered them accommodation and food ... and found people to provide medical help for that lady. In the end, Peter took a pile of money from his wallet and gave it to that guy and the guy said he didn't do all this for money; he just wanted to help them, rather than thinking about how much money this white person could give him. [...] I think this reflects that some people think other people who help them have certain purposes, but, sometimes, others may see you in trouble and truly simply want to help you, without any other aims.

The reasons why LAQ perceived those two scenes as realistic might be either because the narrative was very convincing or because what happens in the story coincided with what LAQ had experienced in China, or both. In addition, as the underlined sentences show, LAQ did not make any distinction in terms of which group of people she was referring to. It appeared that she was talking about people in general, regardless of nationality and country. She was pointing out something people have in common. It can be speculated that LAQ's perceptions of people in general were reinforced.

A male Chinese college student, CJY explained to me why he thought *Prison Break* was unrealistic.

(Q.6.5.2.14)

CJY: 我都看了。在这之前我基本没看过欧美的连续剧,然后看了以后,这主要还是因为情节上的原因吸引我吧。就是情节,悬念非常多。恩...然后文化方面,就是觉得,它上面讲的感觉美国政治非常黑暗,就是什么总统副总统啊,又是副总统制造谋杀,包括,当时现在还没出来,幕后黑手好像是将军还是什么。恩..就觉得好象一切都被操控住了,政府想做什么就做什么。好象挺黑暗的,可能应该是夸张的

Interviewer: 你为什么会觉得它是夸张的呢?

CJY: 觉得那样的话太恐怖了。只是知觉上觉得应该没有那么恐怖吧。我觉得他制度上应该有预防这种事情发生的。政府完全被公司操控,应该没有那么严重。我觉得 *Prison Break* 那个情况,简直太乱了,监狱里面,随便警察跟,当时 *Shaw Shank Redemption*. 那里面和它挺相象的。警察和囚犯有一些很多的交流,很多的,比如说囚犯帮警察干点什么事,他就有一些好处什么的,也挺象的。但是它里面要真的是那么乱,它确实太乱了,我觉得,就是随便找人搞把刀子就可以随便杀人,当然这个还要受惩罚,受乘法是肯定的。还有一次还是,他

在监狱里面闹事吧，打电话也很随便。他们那个地方打电话也很随便。

English translation:

CJY: I have watched all of it. I had never watched Euro-American TV series (TV series produced in European countries or U.S.A.) before that. After I watched, the plot was the main reason that attracted me. It's the plot, lots of suspense. Erm ... about culture, I think, American politics portrayed in the show was very dark, things like the President and the Vice-President, and the Vice-President initiates murder, including, it's not out yet at the moment, possibly the person behind the scene is a general or someone else. Erm... it feels like everything was controlled, the government does whatever it wants to. It seems very dark, probably it's exaggerated.

Interviewer: What made you think it's exaggerated?

CJY: I think it'd be too horrible if it's true. My intuition tells me that it should not be that horrible. I think the system should be able to prevent this kind of things from happening. The government is completely controlled. Should not be that terrible. I think things in Prison Break, too chaotic, in the prison, casually with police, at the time in Shawshank Redemption, it's very similar to it. There's a lot of negotiations between the police and the prisoners, for example, the prisoner will benefit if he helped the police with something etc, very similar. If it's really that chaotic in there, it's indeed too chaotic, I think, simply ask someone to get a knife and then can kill someone, of course will be punished because of this, definitely be punished. I remember, there is one time, there's trouble in the prison, they can make phone calls as they wish. At that place they can make phone calls whenever they like.

Although CJY did not provide detailed reasons why he believed Prison Break was unrealistic, the fact that CJY frequently used the word chaotic to describe how he felt about the stories based on his intuition indicates that there is a gap between the plot and CJY's common sense. For example, the film did not correspond to what he felt it should be like in prison and how government in a country works. The gap between fiction and what happens in real life made CJY perceive the plot to be exaggerated.

Looking at two examples above of LAQ and CJY, it seems that the extent to which the foreign films have a convincing narrative plays an important role in whether or not CCSs perceive foreign films as realistic.

A female CCS, PP told me how realistic she thought *American Pie* was.

(Q.6.5.2.15)

PP: 生活方面. 因为这个太真实了。就是拍的他们大学生的生活，就是...真的是太真实了，你一看就能...哦...原来他们就是...因为是同龄人嘛，我们在这边是这样，他们在那边原来是那样的。真实不敢想象那种。而且很好奇，所以这个了解比较多。

English translation:

PP: Life aspects. Because this is too real. (The film) describes their college students' life, it's, it's truly so realistic, when you watch it, oh, they turn out to be ... because (we are) in the same age, we are like this here, they turn out to be like that over there. I really cannot imagine. Plus, (I am) very curious. Therefore, I can know a bit more via this.

PP's comments as well as her body language and facial expression indicated how enthusiastic she was about the film *American Pie* (there are two sequels; we are talking about American Pie 1). She had so much to talk about and liked the film a lot. Looking at the underlined sentences closely, there might be two reasons why PP perceived American Pie as realistic. First, she found it was very easy to relate to the characters in the film, due to the similarities she shared them. Second, PP's expectation of the film played an important role. Due to the fact that she was very curious about American college students' life, she watched the film with certain expectations which made her perceive the film as a source of information. Based on the fact that PP perceived the film as being realistic, it would be reasonable to speculate that PP has gained a certain understanding of American college students' life from the film. However, whether or not the film is reliable representation of American college students' life is another question.

Now, let us look at another example from the same student, PP, who explained to me what made her believe the clip, *A father-son chat* from *American Pie* was realistic.

(Q.6.5.2.16)

PP: 就是感觉吧。我就是觉得怎么说呢...就是觉得我看了这个片段以后真的想把这个电影就是完全再看一遍。就是挺吸引我的那种。就是他排的那个...就是我以前有过一些了解,就是可能知道一点这方面的知识,然后一看,哦,然后就系统化的,就是真的是这样,然后到底是怎么样的我想把他弄清楚,可能我还会去找别的类似题材的电影去看。就感觉怎么说,就是真实。我就觉得真实的东西就是真的挺吸引人的。

English translation:

R: What makes you think this clip is realistic?

PP: I just feel it. I think, how to say ... I really wanted to watch the whole film after finish watching this clip. It kind of attracts me very much. What they filmed ... I've known some of it, I mean, I may know a little knowledge in this aspect, then watch it, oh, then systematic, it's really, then I want to know exactly, probably I would look for other films with similar subjects to watch. How to say, it's just realistic. I really feel that realistic things attract people a lot.

What PP said reminds me about the previous two examples which illustrate how sometimes the plot is so convincing that CCSs believe it is realistic. PP's comments further indicate another variable, namely *convincing narrative*, which affects CCSs' judgment of whether or not a foreign film is realistic.

Another female CCS, CM, explained to me why she thought the film *Legally Blond*⁶³ was realistic.

(Q.6.5.2.17)

CM: 我觉得那部片子很能反映美国大学生的实际生活。比如说那个女的,本来就很好看,又是金发美女,在学校里很风光,当然就和帅哥在一起。但是约会和结婚是两会事,后来帅哥把她抛弃了。我觉得就很...而且他也有点素食爱情

⁶³ *Legally Blond* (2001): When a blonde sorority queen is dumped by her boyfriend, she decides to follow him to law school to get him back and, once there, learns she has more legal savvy than she ever imagined. (IMDB)

的味道。就是方方面面就是很快的吗，我觉得就是比较能反映...我觉得跟我想象中的美国大学生活比较接近一点。最后她通过自己的努力证明自己不是一个花瓶。我觉得还满贴近现实的。而且影片满搞笑的嘛，我觉得...123 我没全看过，还满好的。

English translation:

CM: I think that film very much realistically reflects American College students' lives. For example, that girl, she's very pretty, plus she's a blonde beauty, very popular in Uni, naturally she goes out with handsome guy. But dating and marriage are two different things. The handsome guy abandoned her later on. I feel that it's very ... plus it feels like 'instant love'. I mean every aspect develops very fast, I feel that it can reflect ... I feel that it's quite close to what I imagined how American college students' lives would be. In the end, she proved that she is not a vase. I think it's pretty close to reality. Plus, the film is quite funny, I think ... I haven't seen all three films, pretty good.

The case of CM shows that sometimes the similarity between plot and CCSs' existing perception on people from the country of origin affects their perception of the reality of foreign films. Therefore, it can be argued that the match and/or similarity between plot and CCSs' existing perception tend to reinforce their existing perception of people and culture in the foreign films' country of origin.

Having watched the clip, *Dining saloon* from the film *Titanic* (1997), which WZT had watched twice before, she talked about the character, Jack.

(Q.6.5.2.18)

WZT: 他是一个异类。我不觉得好多没钱的人可以做到和 Jack 一样。我觉得没钱的人面对有钱的人，他只能有两中态度，要么就是发奋，你看我以后肯定要比你有钱，我要如何如何，比你有钱，要么就是，诶呀反正我是没钱，你就是有钱，你有钱就有你的钱吧，就是比较属于那种自暴自弃的，我也没想过要怎么富起来，反正你过的是你的生活，我过的是我的生活，也不能说是自暴自弃吧自暴自弃那种就是无所谓拉，就这样吧，就是对现在也不满足，但也不想着要做到人家那个地步，就那样。像他这样子，不卑不亢的那种态度，就是，脸上面不改色心不跳的那种，你对我甩过来的冷言冷语，我都是拿我的方式回击过去，我觉得这样的人很少，我不认为现在会有这种人，我觉得一般，没钱的要吗就是特别自卑。

English translation:

WZT: He is different. I don't think many people who don't have money can do the same as Jack does. I think, when the poor face to the rich, he can only have two attitudes, either make a determined effort, look, I will definitely be richer than you in the future, I want to do this and that to be richer than you. Or, well, I am poor anyway, you are rich, you have money so be it, this is the attitude of people who give up on themselves. I have never thought how to get rich, anyway you live your life, and I live mine, it's not actually give up on themselves, it's doesn't care, like this. It's not satisfied with reality, but do not want to really do to the extent like others, like that. Like him (Jack), neither haughty nor humble kind of attitude, it's keeping his countenance and retaining his heart beat, you throw mocking words toward me, I will fight back in my way. I think there are very few of this kind of people. I don't think people of this type exist in the society. I think, normally, the poor usually feel very inferior.

It seems that WZT has strong opinions on how the poor normally behave. Due to the fact that, at the point when I conducted the interview, WZT did not have any direct contact with people from English speaking countries, it can be speculated that these opinions were the result of her personal experience and opinion of the Chinese poor. The conflict between Jack's character and her existing understanding of the poor did not make her question her existing perception of the poor. Rather, it led her to draw a generalized conclusion that a person like Jack does not exist in the society, which means that the character is not realistic.

SYY, a female CCS, talked about the character, Chandler, after watching the clip *Chandler's date* from *Friends*.

(Q.6.5.2.19)

Interviewer: 那有让你对美国男人有认识吗?

SYY: 美国男人就是花花公子型的, 吃喝玩乐。

Interviewer: 你觉得这个片子有夸张吗?

SYY: 我觉得肯定会有些夸张, 在现实生活中我觉得每个人不都是这样吧。肯定也有做事特别稳妥, 而且我相信大部分人是这样的

Interviewer: 大部分人哪样的?

SYY: 这个只有符合他一个人的特点吧, 我觉得。

Interviewer: 你觉得大部分人是怎样的?

SYY: 就是说还是讲责任的。

Interviewer: 你是说大部分美国人?

SYY: 我是这样觉得的。

[...]

Interviewer: 哦, 我明白了。那你觉得这个小片段给你的印象和你平时对美国人的印象一致吗?

SYY: 那到没有。我平时接触到的美国人, 我觉得他们都很绅士风度的。

English translation:

Interviewer: Does it help you know more about American men?

SYY: American men are playboys, eat, drink and be merry.

Interviewer: Do you think this clip is exaggerated?

SYY: I think it's certainly exaggerated. I don't think everyone is like this in reality. There are definitely people who are reliable, plus, I believe most of the people are like this.

Interviewer: Most of the people are like what?

SYY: This only fits his characteristics only.

Interviewer: What do you think of the majority of people?

SYY: They have sense of responsibility.

Interviewer: Do you mean majority of Americans?

SYY: I believe so.

[...]

Interviewer: Oh, I see. Do you think this clip matches your impression on Americans?

SYY: Not really. Americans whom I come into contact with, I think they are all very gentle.

It is worth mentioning that, among all the CCSs, SYY had a lot more contact with people from English speaking countries, in particular, U.S.A., U.K. and Australia, than other CCSs. This is

because of the special context of her university, in which 70% students were non-Chinese students who study Mandarin in Beijing. SY's real-life experience of direct-contact with Americans affected the extent to which SY perceived the character as realistic.

6.5.3 Summary

The current section has identified Chinese college students' sense-making activities in a category which has been named 'perceiving as realistic'.

- **Perceiving as realistic: general to specific**

First of all, making sense of foreign films is a continuum process. CCSs' sense-making activities start even before the actual viewing takes place. For example, findings in this chapter have demonstrated that CCSs already have a perception of to what extent foreign films reflect the reality of the films' countries of origin developed from their previous experiences of foreign films, their experience of Chinese films and their life experience.

Secondly, when it comes to individual foreign films, with regard to 'perceiving as realistic', CCSs' perception and judgment may vary from general to specific.

Finally, three types of CCSs have been identified, *believer*, *doubter* and *sceptic*.

As explained above, *believer* and *sceptic* are two extremes. *Believers* perceive foreign films as window to reality, which makes them vulnerable, in the sense that they might take the foreign films at face value without being critical. Their understanding of and attitudes to people and culture of the U.K. and the U.S.A. will most likely will be affected by them making sense of foreign films. *Sceptics* are almost entirely opposite to *believers*, and perceive foreign films as purely entertainment products which do not have any value in terms of representing anything about the films' countries of origin. *Doubters*, are in the middle between two extremes. This means, although they perceive foreign films as entertainment products, meanwhile, they believe that foreign films, as products of that society, can tell us something about the society.

As mentioned above, with regard to 'perceiving as realistic', students may vary from general to specific. Their *believer*, *doubter* and *sceptic* roles may also change according to context and time. That is to say, some *believers*, who believe that foreign films mirror reality, might become more critical towards an individual film. Also, some *sceptics* who claim foreign films cannot reflect reality at all, may be much less critical and of an individual film or a clip and perceive them as realistic. *Doubters* may also perceive individual films as *believers* or *sceptics*.

In reality, each CCS is a complex individual who might be the combination of all above three categories as to what extent they perceive individual foreign films to be realistic. From an intercultural perspective, a teacher should not assume a student to be either a complete believer or critic all the time, because students' judgments tend to vary for each individual foreign film. Knowing the reasons behind these differences will be helpful for teachers who are keen on using foreign films English language classrooms from an intercultural perspective.

- **Perceiving as realistic: variables**

Several variables have been identified as affecting the degree to which CCSs perceive films as being realistic. Firstly, students seem to respect and value *authority* a lot. Authority appears to be one main variables which affect CCSs' perceiving as realistic activities. Authority takes different forms, such as *native English speakers*, *film reviews*, *award-winning* and *rearranged-from-true-story*. This means sometimes CCSs perceive foreign film as realistic simply because they are made by natives of target countries or rearranged from a true story, such as the death of the Princess Diana in the film *The Queen*. At times, some CCSs tend to judge one or more foreign films as realistic because of positive film reviews. In some extreme cases, CCSs perceive a film, such as *Crash*, as realistic merely because it won an award, even though they have not seen the film yet.

The second main variable which appears in the findings frequently is *close-to-life*. To be more specific, to what extent what is portrayed in the film is similar to what CCSs see, know and experience in their real life effects this type of sense-making activities. The more similar it is, the more realistic the film appears to the CCSs.

Two other variables, which have to do with the quality of foreign films, have been identified, *acting quality* and *convincing narrative*. Sometimes an actor's acting is so good that CCSs perceive the character in the film as realistic. Similarly, at times, a story narrative is so convincing that CCSs perceive it as real. With regard to the variable *convincing narrative*, there seems be a link with the variable *close to life*. Take *Prison Break* as an example. All CCSs who mentioned this show told me that it is not realistic because it is too chaotic and exaggerated. This is most probably because CCSs notice that story is far from being close to life, which made the narrative unconvincing.

In addition, CCSs' viewing expectations and motives strongly affect their perceiving as realistic activities. For example, PP perceived *American Pie (1)* as realistic because she expected to learn about American college students' life from the foreign film prior to the viewing.

Last but not least, CCSs' knowledge and existing perceptions of the people and countries of the foreign films origin, as well as real-life experience, such as direct-contact with natives, play an

important role in CCSs' perceiving as realistic activities. Although existing perceptions and direct-contact with natives have been identified from data findings, it can be assumed that CCSs' overall existing framework of knowledge and real-life experience play essential roles all the way through their sense-making activities.

6.6 Chapter Summary

It would be reasonable to argue that Chinese college students rarely just sit there and watch foreign films passively. Clearly they are very active viewers, and there is so much going on in their mind. The process of making sense of foreign films is far from the linear process many language instructors assume. The sense-making activities are dynamic, complex, unpredictable and culturally specific.

The rich empirical findings suggest that sense-making activities fall into five main categories: comprehending the plot; compare: identifying differences; compare: identifying similarities; re-contextualizing; and perceiving as realistic.

The word 'imagination' struck me so much when I analyzed text extracts in the re-contextualizing category. Re-contextualizing and imagination go hand in hand. Imagination allows CCSs to travel between reality and the fictional context. Imagination carries CCSs to worlds that never were. It allows CCSs to be able to interact with fictional characters and experience a fictional and foreign world. It provides a space for self-reflection, comparison and enriches meanings of experience from making sense of foreign films.

At this point, as a researcher in intercultural studies and an English language teacher, I am struck by the potential value and power of foreign films in the language classroom my findings have uncovered, especially from an intercultural perspective. The educational implications for English language teaching from intercultural perspective will be addressed in detail in the discussion chapter.

Having illustrated the empirical findings for Research Question 3, the following chapter will report the findings related to Research Question 4, which deals with the effect from foreign-film viewing on Chinese college students' understanding of and attitudes to other peoples and cultures.

Chapter Seven: Data Analysis – Research Question 4

The previous chapter identified five main categories of sense-making activities relevant to Research Question 3 (RQ3), which investigated how Chinese college students make sense of foreign films (including both films and TV series). The current chapter reports the empirical findings relevant to Research Question (RQ) 4.

RQ4: Are there any discernible effects of foreign film viewing on Chinese college students' understanding of and attitudes to other peoples and cultures? If so, what are they?

As explained previously, the qualitative data gathered by semi-structured individual and group interviews mainly aimed to answer RQ3, which is the core research question. However, it was also hoped to elicit empirical findings relevant to RQ4. In the process of data analysis, I came to the realization that there is a very thin and blurred line between making sense of foreign films and being affected as the result of viewing the film. For example, a student forms his or her own interpretation of the film after viewing it. As a result, an understanding of and/or an opinion/view on the subject of the film is formed. There is a blurred line between the understanding/view resulting entirely from the student's existing framework of knowledge, and the understanding/view being the effect of the film-viewing. Hence, whether the film-viewing influences student's understandings of and views on a subject, or whether the film-viewing simply triggers the recall of existing knowledge is not always easy to tell. To identify clear and strong evidence of effect is not as easy as might be expected.

To gain strong evidence of effect, long-term ethnographical research would be ideal. The current research was to a large extent just a snapshot which captures the students' understanding/views at a particular time, although there was some limited potential to identify effects by questioning them before and after exposure to various film clips. The data gathered from the interviews turned out to be rich and dynamic, and, as shown in the previous chapter, provides strong evidence for Chinese college students undertaking a range of sense-making activities during film viewing. However, identifying evidence of effect is quite another matter, because the students' views and opinions can be affected by many other resources, not only by film-viewing. Nevertheless, several possible effects of watching films have been identified, and these will be discussed in this chapter.

The word effect is a broad term. Films can have effects on audiences' emotions, behaviours, ways of thinking, knowledge and attitudes etc. The empirical data does show there is significant impact on students' emotions as result of film-viewing. However, as stated in the RQ4 above, the focus of

the current study is to identify the possible effects on CCSs' knowledge of and attitudes to peoples and cultures as result of foreign-film-viewing.

In the previous chapter six main categories of sense-making activities ('comprehending the plot', 'compare: identifying differences', 'compare: identifying similarities', 're-contextualizing' and 'perceiving as realistic') have been illustrated through interview extracts, and several of these extracts also provide positive evidence that foreign-film viewing affects Chinese college students.

One of the main findings, which may be surprising to some, is that sometimes foreign-film viewing not only has effect on Chinese college students' understanding of and attitudes to otherness, but also has effect on Chinese college students' understanding of and attitudes to themselves and Chinese people in general. Hence, the effect is two way. Empirical evidence for this finding will be provided and discussed step by step in the rest of the chapter.

7.1. Effect on Understanding of and Attitudes to Self/Significant Individuals

(Q.7.1.1)

SYY: 我觉得他们师生之间是特别平等的关系, 不管你是说, 你的观点我是否同意, 我都表示对你的一种尊重。在国内的话, [...] 不过就是说在高中初中时候, 我确实遇到那个问题, 好象老师说一就是一说二就是二, 而且我们是以考试答案为标准的。

English translation:

SYY: I think there is fairly equal relationship between the teacher and the students. No matter whether I agree with your view, I show respect to you. In China, [...] when in high school, I indeed encountered that problem. It seemed teacher was always right, no matter what. Everything was measured by exams.

Having watched the clip *Step off*⁶⁴, SYY compared and identified the differences between the relationship between fictional characters (students and their teacher) with that between her and her teacher in high school. SYY's comments, in particular, the words 确实 (indeed) and 问题 (problem) indicate that prior to watching the clip she already wasn't happy with her teacher-related-experience in high school. Hence, it is unlikely that SYY formed this negative attitude for the first time as the result of clip-viewing. Her existing understanding and attitude were probably triggered by the clip-viewing. As a result of identifying differences between herself and the characters, her understanding and attitudes most probably were reinforced. Data indicates that many interviewees shared similar understandings and attitudes with SYY with regard to the relationship between teachers and students in China and the teacher's approach towards students. By providing a contrasting model in the fictional teacher, her understanding of which

⁶⁴ Step off: a clip chosen from the film *School of Rock* (2003). In the clip, a substitute teacher, who used to be member of a rock band, saw a boy was criticised by his father before he entered the school in the morning. He then tried to encourage students to express their anger and unhappiness through rock music.

aspects of her interaction with her own teacher made her unhappy may have also been refined. However, she does not generalize her attitude to all Chinese teachers.

The above text extracts illustrates that sense-making activities, such as identifying difference between fictional character and self, may lead to reinforcement and refinement. These are associated with student's existing understanding and attitudes towards self and/or significant individuals. A text extract used in the previous chapter (Q.6.2.1.1) also indicates the same effect.

7.2 Effect on Understanding of and Attitudes to Groups of Chinese People in General

In the previous chapter, text extracts (Q.6.2.2.6), (Q.6.2.2.7) and (Q.6.3.2.5) indicate that sense-making activities such as 'compare: identifying differences between fictional character and group of Chinese people in general' may lead to reinforcement and refinement of understandings of and negative attitudes to a group of Chinese people in general (in these cases Chinese parents). Let us look at another example below.

(Q.7.2.1)

JT: 他们就是一种相对比较理智的一种态度吧。然后中国可能比较感情用事一点，就觉得自己的孩子，为什么不能管？我就不准他这个样子，我是他妈妈，我生他，为什么我连管他的权利有没有？就比较感情用事。他们就会比较理智，就不想自己是不是父亲还是母亲，然后去降低自己的告诉，做朋友，去看待这种问题。

TXH: 我觉得中国的父母对子女寄与太多的希望。而且就是把自己子女当做是，好象不希望走自己的错路，想把他们引导到自己希望的路上来，但是往往有时候小孩子未必会明白，未必会理解，就发生一些冲突，而且曾经听说过说中国的小孩子是在英国长身体的时候就是拼命学习，背负太多的压力，然后到了大学了，一下子就都放松了，有一些人是这样子的，我爸爸那个时候大概就是这样子的。他们把自己的小孩子当成一个独立的人来看，没有把他们设置在自己，十分希望他做一什么，望子成龙这样的角度来看。就是，希望他比较健康快乐的成长，而不是那种希望他们会成功或者怎么样。

English translation:

JT: They have a comparatively more sensible attitude. And Chinese parents are comparatively more emotional. They feel that why can't I exercise control over my own child? I don't allow him/her to do this, I gave him/her birth, why don't I have the right to discipline him/her? Comparatively more emotional. They are relatively more sensible. They don't act like parents, they act like friends instead.

TXH: I think Chinese parents have too high hopes for children. Plus, they treat own children in such a way that they don't seem to want children to make their own mistakes. They want to guide the children to go the way that they want. But the children do not necessarily understand. Hence, the conflicts. Plus, I heard that Chinese children work super hard while British children develop physically. Chinese children suffer from too much pressure, and suddenly relax after enter the university. Some people are like this. My dad was like this at that time. They treat their children like independent adults. They don't wish their children to become top of the cherry. They wish them to grow-up with happiness and health, instead of just focusing on being successful.

Having watched the clip *London bench day*⁶⁵, JT and TXH both compared the fictional character (Sam's dad) with Chinese parents in general, particularly in terms of the parents' parenting approach to children. In addition, TXH compared her dad with the fictional dad. Both of the above students also showed the tendency to generalize about Chinese parents. It seems that TXH mainly developed this generalization based on her personal experience. In the process of data analysis, it seems that many interviewees shared similar views on Chinese parents' approach to children. Hence, it can be speculated that TXH's and JT's views on Chinese parents were due to their existing perceptions prior to the clip-viewing. However, the text extract above indicates the possible reinforcement of their existing understanding of Chinese parents as the result of clip-viewing. They may also have refined their ideas of the aspects of Chinese parenting that they disliked by observing the fictional character behaving in a contrasting way.

All four examples (three from the previous chapter and the one quoted above) indicate that sense-making activities, such as 'compare: identify difference between fictional character with group of Chinese people in general', sometimes lead to reinforcement (and possible refinement) of an existing understanding of a group of Chinese people. Reinforcement of an existing negative attitude was indicated by three out of four of the examples.

7.3 Effect on Understanding of and Attitudes to Generalized People Represented by Fictional Character(s)

Chinese college student DYY had watched the film *Crash* prior the interview. Having watched the clip *Two black men* again, he said:

(Q.7.3.1)

DYY: 黑人还是过于敏感了, 过于敏感, 就是说, 还是长期受到那种压抑, 会很尖锐。面对事情有时候会失去理智。白人, 他们确实很优秀。在各个领域都是主流。因为他们主流角色, 会很自然印发别人的一种嫉妒吧。亚洲人还是那个, 一部大制作里面的小角色, 永远是成不了主角。[...] 他们可能就是处于那种只能勤劳的干, 不能够有一些很正义, 很让人出忽意料的那种举动, 他们的生活都偏于平庸。象他们经营的都是一些餐馆, 杂货店, 冒险精神还是差了一点。

English translation:

DYY: The black are overly sensitive, overly sensitive. I mean, they have been constrained for long time. Hence, their attitudes are intense. The white, they are indeed very outstanding. They are the main stream in various kinds of fields. Being in the main stream naturally causes others' jealousy. Asians are, small characters in a big production, can never become main characters. [...] They seem to be only able to work diligently. They don't have strong sense of justice and don't act against expectations. They tend to live ordinary live. Like, they usually run business like restaurants and grocery stores. They are relatively lack of spirit of taking risks.

⁶⁵ London bench day: A clip chosen from British film *Love Actually* (2003). In the clip, the 11-year old boy Sam sits on the same bench with his step-dad. Sam's mom just passed away. Sam has been very upset. His step-dad decides to have a chat with him to find out what troubles him. Sam confessed that he's in love with a girl.

The clip was about two twenty-something year old black men robbing a white couple's car and running off. Data indicates that the most of the interviewees were aware of the racial conflicts between the whites and the blacks in the U.S.A. prior to interview. Hence, it can be speculated that the clip-viewing reinforced DYY's understanding of the blacks and the whites in the U.S.A. The word he used to describe the white, such as 'indeed very outstanding' (确实很优秀), and the way he described the black as 'overly sensitive' (过于敏感) indicate his positive attitude to the white and negative attitude towards the black.

There were no Asian people in the clip. However, DYY's may have formed his view of Asians as result of whole-film viewing⁶⁶. Although it would not be reasonable to conclude that DYY formed this view solely as result of film-viewing or clip-viewing, it can be suggested that film-viewing has reinforced his existing view of Asian people in general. As mentioned in the previous chapter, when Chinese people talk about Asians, they refer to East-Asians.

The film *Forrest Gump* gave GW very deep impression after she watched it in the first-year of college. She said:

(Q.7.3.2)

GW: *Forrest Gump* [...] 这个片子在大一的时候看了一遍，所以我印象特别深刻。但是看的时候就觉得 Forrest，人家说他是智障，就是我觉得他，老师也说过，在那个片子里面宣扬的思想就是，一个被感觉好象就是，被上帝放弃的人，就是任何人都有闪光点，在美国的社会很自由，就象你这个人在平常人身上看来很多不足啊，但是只要身上有闪光点在那个社会就会被发觉，会能得到自己的发挥自己的作用，只要坚持下去。

English translation:

GW: *Forrest Gump* [...] I watched this film once in the first-year. Hence, I have a deep impression of it. When I watched it, I felt that Forrest, other people say he is retarded, I think he, our teacher also mentioned to us that, the film wants to advocate that a person who seems to be abandoned by the God, everyone has own good quality. American society is a very free society. Even if you seem to be having a lot of shortcomings, as long as you have own good qualities, as long as you keep going, you eventually will realize your own value.

As the first underlined sentence, in particular the words 印象深刻 (deep impression), indicates that the film had strong impact on GW. It seems that GW refined her understanding of American society as result of viewing the film. Data indicates that perceiving American society as free society is a common view shared by most of the interviewees. Hence, it can be speculated that GW's views on American society existed prior to the film-viewing, and that the film-viewing refined and reinforced her existing understanding of the country.

⁶⁶ Crash (2004): the film includes several stories interweave during two days in Los Angeles involving a collection of inter-related characters from difference races in the U.S.A. The clip DYY watched portrays two car thieves (black) who are constantly theorizing on society and race, rob the car which belongs to a white district attorney and his irritated wife (white), especially after she's robbed. In the film, there's also an American-Korean couple who are people traffickers.

The above two text extracts suggest that film-viewing may reinforce students' existing understanding of groups of people represented by the fictional characters. This is most likely to occur when the fictional characters are similar to students' existing perception of the people represented by the fictional character, and as a result, existing perceptions are confirmed and reinforced. Another example, (Q.6.5.2.17) which has been presented in the previous chapter, also indicates that the similarity between the fictional characters and the students' understanding of American college students is the main variable in the characters being perceived as realistic. As a result, reinforcement occurs.

The examples above indicate that film-viewing may lead to refinement or change of Chinese college students' existing understanding of the group of people represented by the fictional characters. The main variable governing the occurrence of this type of effect is the degree of similarity or contrast between the fictional character and viewer's existing images of the people represented by the fictional character.

As discussed in the previous chapter (see Q.6.5.2.15), as the result of sense-making activities such as 'perceiving as realistic', students sometimes gain more knowledge about people represented by a fictional character. In addition, due to the fact that students share different frameworks of knowledge and life experience, as well as different personal characteristics, making-sense of foreign films is a dynamic and complex process, the results of which are sometimes unpredictable.

For example, HWY told me what she had learned from *American Pie* and *Mean Girls*, both of which she had watched prior to the interview.

(Q.7.3.3)

HWY: 我觉得，其实这些片子，就象 *American Pie* 还有 *Mean girls*，它不是讲的高中生活嘛，所以我觉得，它吧，就是美国人当下年轻人，那种有一点焦虑，然后，不想刻守传统，然后，美国那个，然后，因为它是世界第一大国，所以，美国人又特别希望，站在一个特别高的姿态，因为，然后可能觉得自己本国东西是最好的，然后又强调人权自由啊这种东西，它拍出来的片子其实有些是很多普通人的梦想，[...] 因为很多人看这片子就会产声共鸣，觉得那个是就是真实生活中的自己。然后，所以很多片子看到后来觉得很温馨，但是是一个套路，就是，你知道它最后会有点煽情，告诉你做人的道理。这是，可能是美国人自己内心缺乏那种安全感，然后，才会拍这样的片子找到一些安慰。

English translation:

HWY: I think, actually these films, like *American Pie* and *Mean Girls*, they are about high school students, hence I feel that, the current American young people are a bit anxious, and don't want to follow the traditions. The U.S.A., because it's the most powerful country in the world, hence, Americans want to, because they believe things from their country are the best, and also they emphasizes human rights and things like that, the films they produce include a lot of common people's dreams [...], because many people will develop sympathetic response to the film, think that's themselves in the reality. Hence, feel very warm by viewing many films. But those

films follow the same pattern, which is, you know that in the end it will be emotional, and telling you the truth in life. Perhaps this is because Americans are lack of sense of security and hence produce this type of films to seek for some comfort.

Although *American Pie* and *Mean Girls* are about high school students, HWY reached a generalized view on American young people as result of viewing the two films. In addition, HWY has a specific view about the reasons and motivations of the people who produced the films. In doing so, HWY drew on other generalized perceptions of American people which may have been developed or reinforced by reflecting on *why* films like *American Pie* and *Mean Girls* were produced. Again, the second underlined sentence indicates the potential strong impact from films on audiences, including their emotions.

Comparing HWY with all previous students, they all showed the tendency to reach a generalized understanding of self and/or other as result of film-viewing. What makes HWY different is that, in addition to making sense of the content of the films, she went a step further to interpret film-makers' motivation and reasons of production. In doing so, her views of American people may have been refined. It seems that HWY's interpretation of the motivations of the film producers may have been a cause of her view of Americans being insecure. However, a pre-existing view of the insecurity of Americans may also have lead to her interpretation of the film producers' motivations.

The current chapter so far has illustrated the effects of foreign film-viewing on Chinese college students' understanding of and attitudes to themselves, significant individuals around them, generalized groups of Chinese people and generalized people represented by the fictional character(s). In addition to the evidences presented in this chapter, text extracts reported in the previous chapter also indicate the effect on understanding of and attitudes to generalized groups of Chinese people and generalized people represented by the fictional characters (i.e. Q.6.4.3.2; Q.6.2.3.6). The effects identified so far are mostly reinforcement and refinement of existing understandings and attitudes. It is difficult to separate creation of new understandings and attitudes from reinforcement and refinement, as the subjects of the study had already been exposed to many influences prior to the interviews and clip-viewing taking place, and would have had pre-existing understandings and perceptions about all of the subject matter presented. The influence of film in forming these attitudes in the first place can only be speculated. However, distinguishing examples of foreign films challenging existing knowledge/understandings/attitudes is easier.

(Q.7.3.4)

GW: 可能是我们平时对美国了解的很肤浅不够深刻吧。我觉得看这个片子的时候，那个时候是在上高中，不象在大学，接触的外国人也有，视野这么开阔。

那时候就是感觉看这个挺触动的，跟一贯的美国人在中国人的心目中那种形象定式就感觉完全不太一样。而且这个女主角特别喜欢日本古老的文化，她去东经，京都，日本最具有古老文化的城市，看日本传统的婚礼，去寺庙什么的，就是感觉特别触动，就是外国人，西方人对那些亚洲的文化也特别感兴趣吧。挺触动的。

English translation:

GW: Perhaps our understanding of the U.S.A. is superficial and not deep enough. When I watched this film, I was in high school at the time, not like in the university, have access to foreigners, have widened vision. At that time, I was deeply stirred emotionally by this film, the character was different from the usual images of Americans in Chinese people's mind. Plus, this female character likes ancient Japanese culture very much. She went to Tokyo, Kyoto, the oldest cultural city in Japan. She watched the traditional Japanese wedding, went to temple. I was deeply touched. It seems foreigners, westerners are also very much interested in Asian culture. I was deeply stirred.

Viewing the film *Lost in Translation* (2003) affected GW differently to all of effects illustrated so far in the current chapter. The female character does not fit GW's existing stereotypes of Americans. As GW pointed out during the interview (see Q.6.3.2.6 in chapter six), she felt that the female character did not conform to the image of a typical American she had in her mind. Instead, she felt that the fictional character was more similar to an East-Asian. It seems that the fictional character challenged GW's existing images of Americans. As a result, GW developed an altered understanding of not only Americans, but also Western people in general. This also shows her tendency of generalization. From an initial stereotype of Americans as having no interest in foreign culture, she now thinks westerners in general have an interest in Asian culture. The underlined sentence indicates that her change of life experience through direct contact with foreigners seems to have reinforced the change in attitude first stimulated by film-watching. Although GW did not specify the nationalities of the foreigners she had contact with and the nature of their relationship (be it stranger, acquaintance or friend), what she had learned and experienced in the college also countered her initial stereotype of Americans. She did not realise that, like the fictional character in *Lost in Translation*, foreign students and foreign teachers in China would naturally be those foreigners interested in Asian culture, and perhaps not typical of all foreigners. Again, the words 挺触动的(deeply stirred emotionally) indicate the emotional impact from the film.

GW was not the only interviewee with direct contact with foreigners. SYY had several friends from English speaking countries, including the U.S.A. Canada and Australia. Observing these two students closely, it seems that their experience from direct contacts with foreigners plays an important role both in terms of making sense of foreign films and the effect on them.

The example from GW (Q.7.3.4) indicates that direct contact with foreigners reinforced the effect of change of existing stereotypes of Americans. Data gathered from SYY also suggests a similar

finding. Having watched the clip *Chandler's date*, unlike some other students who perceived Americans as casual and do not care so much about marriage after viewing the same clip, SYJ pointed out that the image portrayed in the clip (she was referring to Chandler) is not the same as the Americans she knew in the reality who appeared to be very gentle and polite. She indicated that although she had seen many other films portraying similar images of Americans, she believed that Americans in real life are not like that. This is also an example of SYJ challenging what she perceived to be a stereotype (Chandler in the clip). In this case her stereotype was based on the foreign American students she knew, and her response was to reject the challenge, unlike GW, who accepted the challenge to her stereotype represented by *Lost in Translation*. However, both students put more faith in their own life experience of a limited number of foreigners than in the stereotypes represented in many foreign films.

7. 4 Reinforcing/Challenging Philosophy of Life

(Q.7.4.1)

LAQ: 那片子其实还不错，我那时候和我同学还在讨论，我说这个片子拍的那么恐怖，现在做过山车，狠多人看了那部片子以后肯定都不敢坐了。我说你说那个片子他要告诉人一个什么道理啊，拍的那么恐怖！其实我也不知道是什么意思，拍的那么恐怖能有什么意思啊？她说，就是要告诉你，生活中任何一个很小的失误都有可能导致人的死。

Interviewer: 那你个人觉得呢？

LAQ: 我觉得对。其实我当时看这个片子我没看完，我是和同学晚上在网吧刷夜的时候，她在看那个片子，看的我就特别害怕，我就看不下去了，不感看了，因为拍的确实挺恐怖的。然后后来那天和那个同学聊天无意中说起这个片子了，我就说，你说他拍那个片子有什么意思，其实我还不明白是什么意思，拍那个片子，那么多吓人的东西有什么意思啊，就跟我讲这个道理，后来我仔细一想确实是这个。

English translation:

LAQ: That film is actually not bad. At that time, I also discussed with my course mate, I said this film is so scary, like the roller coaster, many people are too scared to sit on it after seeing that film. I asked her what do you think that film wants to tell us, such a scary film. Actually, I didn't know what the film wants to tell us, what else can a scary film tell us? She said, the film wants to tell you that any single mistake in life can lead to death.

Interviewer: What do you think?

LAQ: I think she's right. Actually I didn't watch the full film, we watched the film on-line in internet bar, she watched this film, I was too scared to keep watching it, I didn't dare to watch it because it's really very scary. Then, when we were chatting the other day and we mentioned this film accidentally, I asked, what do you think that film tells us. Actually I didn't understand what that film was about, couldn't figure out the meaning of it with so many scary things. Then she told me what she thought. I thought about it carefully later on and I think she's right.

The film LAQ was talking about is *Final Destination 3*⁶⁷. What the above text extract shows is neither effect on attitudes towards self nor effect on attitudes towards others, but rather effect on one's philosophy of life. As discussed before, due to the dynamic and complex nature of making sense of foreign films, sometimes film-viewing has unexpected effects on students. Although what LAQ said at the beginning looks a bit superficial, she still ended up having a generalized view on philosophy of life. The underlined sentences indicate that there is another variable for effect, peer influence. The meaning of the film was not obtained directly by LAQ, but from her friend. It can be speculated that it had added weight coming from a friend.

Another example (Q.6.3.1.11) was presented in the previous chapter where a male student XY's philosophy of life was affected after viewing the film *American Beauty* (1999). The text extract shows strong evidence that the forty-something fictional character Lester's determination and efforts on pursuing high school girl Angela had impact on XY's philosophy of life. As the result, XY developed the view that he should not be afraid of failure and should pursue his desires.

7. 5 Summary

To sum up, making-sense of foreign films *sometimes* affects Chinese college students' understanding of and attitudes to not only themselves and generalized groups of Chinese people, but also generalized group of people represented by fictional character(s). The effect is two dimensional, Self and Others. Here, 'Self' includes both the individual and Chinese people in general. 'Other' indicates foreign people represented by the fictional characters.

Distinguishing between *learning/developing new* knowledge/understandings/attitudes and *reinforcing/refining existing* knowledge/understandings/attitudes was difficult, as the research subjects were all well-educated young adults, who had been exposed previously to the subject matter addressed by each of the films used in the study. However, *challenges to existing* knowledge/understandings/attitudes were easier to distinguish.

Four categories of effects emerged from the data.

- Reinforcement of understanding of and attitudes to self/significant individual: (Q.7.1.1)
- Reinforcement of understanding of and attitudes to generalized group of Chinese people: (Q.7.2.1)

⁶⁷ Final Destination 3 (2006): A student's premonition of a deadly rollercoaster ride saves her life and a few of her friends but not from death itself which seeks out those who escaped their fate. The survivors mysteriously start dying and it's up to Wendy to stop it before she's next. The two girls LAQ was referring to are two friends of Wendy's who, among a few of others, survived from the deadly rollercoaster ride. The two girls go to Salon to get fake tan but end up dead in the fake tan machine (the oven LAQ refers to).

- Reinforcement of/challenge to understanding of and attitudes to generalized group of foreign people represented by fictional character: (Q.7.3.1), (Q.7.3.2), (Q.7.3.3)
- Reinforcement of/challenge to philosophy of life: (Q.7.4.1)

It is notable that viewing foreign films allowed Chinese college students to *reinforce* and *refine* their understandings of and attitudes to 'Self', where 'Self' includes the individual Chinese student, other Chinese individuals, groups of Chinese people and East-Asian in general, but not to *challenge* these understandings/attitudes. On the other hand, foreign films were able to *reinforce*, *refine* and *challenge* both understandings of and attitudes to 'Others' (where 'Others' indicates groups of foreigners), and to *reinforce*, *refine* and *challenge* the students' philosophy of life.

Three variables have been identified with regard to the effects on Chinese college students as a result of foreign film-viewing.

- Framework of knowledge
- Life experience (e.g. direct contact with foreigners)
- Peer influence

The previous chapter showed that Chinese college students' existing *framework of knowledge* and *life experience* are two main variables which affect making sense of foreign films. A number of text extracts in this chapter have illustrated the essential role these two variables also play in terms of the effect of foreign film-viewing on students. Other examples of the role of these two variables on effect in chapter six include (Q.6.4.2.3) and (Q.6.4.2.4). Data indicates that although *direct contact with foreigners* is limited, among all the interviewees, two students (GW and SYY) had foreign friends. As discussed above, it seems that their experience from direct contact with foreigners plays an important role in terms of making sense of foreign films and the effect of those films on them. Both placed more faith in their own experience of contact with a limited number of foreigners than in the stereotypes presented in foreign films.

Peer influence was shown in the last chapter to influence how Chinese college students make sense of films. This chapter also identified it as a variable influencing the effect of foreign films on the students.

To conclude, the current chapter has reported the empirical findings relevant to Research Question 4, relating to the effect on Chinese college students' understanding of and attitudes to Self and Others as result of foreign film-viewing. In addition to illustrating that effect is two-dimensional, the nature of effect, in terms of *reinforcement/refinement of* and *challenge of* existing understandings and attitudes, has been discussed.

Chapter Eight: Discussion

First of all, let us revisit the research questions for the current study.

- RQ1: From which resource do Chinese college students (CCSs) think they learn the most about the people and cultures of English speaking countries, in particular the U.K. and the U.S.A.?
- RQ2: What type(s) of media do CCSs prefer to use in order to learn about people and cultures of the U.K. and the U.S.A.?
- RQ3: How do CCSs make sense of films and TV series produced in other cultures, specifically films and TV series produced in the U.K. or U.S.A? (core question)
- RQ4: Are there any discernible effects of foreign film viewing on CCSs' understanding of and attitudes to other peoples and cultures? If so, what are they?
- RQ5: What is the current status of using English films and TV series in ELT classroom?
- RQ6: What are the theoretical and pedagogical implications for English teachers in the Chinese context?

The purpose of this discussion chapter is to use the results of the current study and the existing literature to produce a Foreign Media Sense-Making (FMSM) model, and to discuss the theoretical and pedagogical implications of the research on the use of foreign films (including both films and TV series) in English language teaching (ELT), particularly in terms of developing intercultural communicative competence (ICC) in the Chinese context.

Empirical findings for the first four research questions have been presented in the previous three chapters. Research Question 5 has been partly answered by the literature analysis on using films in English language teaching both in Chinese and non-Chinese contexts (section 3.3). Some data has also been collected from the semi-structured interviews with Chinese college students with regards to how their teachers have been using films in the English language class. The findings from this data will be presented in the discussion later in this chapter. Research Question 6 will be answered later in this chapter.

As the three data analysis chapters show, both quantitative and qualitative data is rich. In particular, the qualitative data gathered from semi-structured interviews is very complex and dynamic. During the course of qualitative data analysis, one main feature which stood out was the tension between the 'particular' and the 'general'. Due to the fact that the students are highly diversified in terms of their framework of knowledge, life experience, beliefs and values and personalities etc, their sense-making activities are also highly diversified, individualised and,

sometimes, unpredictable. The films students watch are also very different from each other in terms of subject, plot, genre and context. Each individual student and each individual film could be in a separate category. However, several common categories of sense-making activities emerged from the highly diversified data, together with the key variables which affect how individual students undertake these activities. Although the sense-making activities have been presented in different categories on different levels, it is important to be aware that the activities always intertwine and integrate together.

As discussed, the empirical findings to the first two research questions demonstrate the importance of the main part of this study, how Chinese college students make sense of foreign films (including TV series). Given that foreign films are the primary resource from which CCSs learn about peoples and cultures of the U.K. and the U.S.A., and given that students would like to make more use of these resources, English language teachers must understand how students make sense and learn from foreign films. It is also important for teachers to know how films can affect students' understandings of and attitudes to peoples and cultures as result of viewing the foreign films, together with the skills and abilities that can be developed through making sense of the films. This knowledge will allow teachers to develop classroom activities based around foreign films.

8.1 A Foreign Media Sense-Making Model

8.1.1 Mass Media Communication Models

Section 3.1.1 of the literature review discussed current models of mass media communication. Many of these models are similar to Hall's (1980) model, which is presented again in Fig. 8.1 below. The interest of the scholars who develop these communication models is in the communication process between the producers of the media and the audience. The focus is on the message which is encoded by the producers and then decoded by the audience, and the variables influencing the differences between the intended meaning and the received meaning. Cultural background and framework of knowledge of both producer and audience are seen as things underlying this process.

As discussed in the literature review, Hall's model applies to TV series and films (both domestic and foreign) and the audience. Hall points out that both communicators, the producers of the media program and the audience, are affected by their own cultural background. The current study confirms Hall's argument that the meaning as decoded does not necessarily correspond with meaning as encoded. As a matter of fact, meanings decoded by audiences are highly diversified. Although Hall developed the model in the domain of culture and points out that

audience’s cultural background affects making sense of media, Hall did not explain *how* and *in what way* cultural background affects the audiences. Also, Hall’s model only gives a general process of media and audience communication. No details were given in terms of decoding activities.

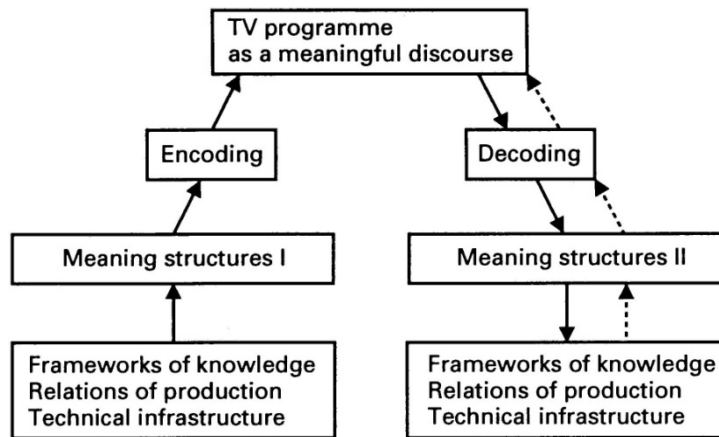

Fig. 8.1 Hall’s encoding/decoding model (Hall 1980)

This study focussed on understanding the decoding branch of the process. The empirical findings show that when Chinese college students watch films made in the U.K. and the U.S.A., they do far more than decoding messages encoded in the film by the producers, and this is why the term sense-making has been used. In chapter 6 five categories of sense-making activities emerged from the data, ‘comprehending the plot’, ‘compare: identifying differences’, ‘compare: identifying similarities’, ‘re-contextualizing’ and ‘perceiving as realistic’. Although one outcome of these activities was ‘interpretation of plot and characters’, which corresponds to ‘meaning structures II’ in Hall’s model, there were clearly other outcomes in terms of effects on the students knowledge and attitudes towards both foreign people and Chinese people, and even effects on their philosophy of life.

Hall’s model also suggests that the viewer decodes the media product and then combines the results of the decoding with their ‘knowledge base’ and other variables to obtain the meaning. However, my study found that variables such as knowledge and life experience affected the sense-making activities directly, and that the final interpretation of plot and characters (meaning) is only one of the results of the sense-making activities. Direct effects on knowledge, attitudes and the other changeable variables also occur as a result of the sense-making activities.

Chapter five found that Chinese college students mainly watch films made in the U.K. and the U.S.A. 1) for entertainment; 2) to improve their English; and 3) to learn something about foreign people and culture. While one of the intentions of the producers of the films is to entertain

domestic audiences, it is fairly safe to assume that they do not intend to help foreigners to learn English and to learn about the people and cultures of the U.K. and the U.S.A. Therefore Hall's communication model cannot capture entirely the observations of this study.

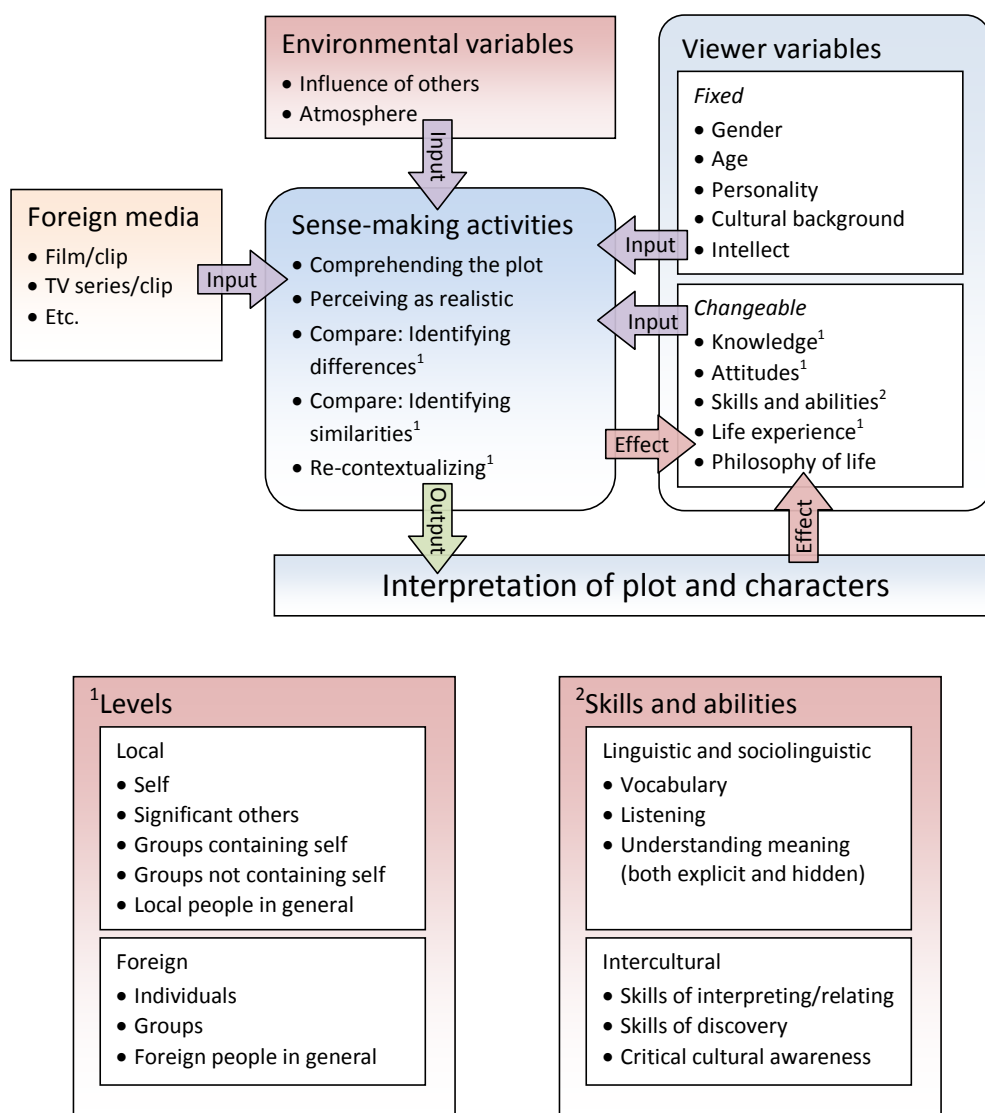

Fig. 8.2. Foreign Media Sense-Making (FMSM) Model

8.1.2 Structure of Model: Foreign Media Sense-Making

This study sees the Chinese college student as a 'consumer' of foreign films. Foreign films are viewed as cultural media products of a foreign culture. A new 'Foreign Media Sense-Making Model' has been developed directly from the research findings, and is illustrated in Fig. 8.2. Although the new model is developed from the empirical findings of current study in the Chinese context, which aimed to unveil how Chinese college students make sense of films and TV series produced in the U.K. and the U.S.A., it should be applicable to foreign media in general, including films, TV series, radios, newspaper, novels etc., wherever the media are 'foreign' to the viewer in the sense of being the product of a foreign culture.

In this model, foreign media refers to all types of media including films, TV series etc. In addition, the media can be either a clip or the whole program. The key components of the new model are the sense-making activities, the variables related to the Chinese student viewing the foreign film and performing the sense-making, and variables related to the environment in which the student views and makes sense of the film. The five categories of sense-making activities emerged directly from the data during the analysis presented in chapter six. Variables affecting the outcome of these activities were also identified for each category of sense-making activity (chapter six) and for the observed effects (chapter seven).

8.1.3 Viewer Variables

In the model, variables related to the viewer have been divided into two types, *fixed* variables, which are those that cannot be changed by watching films, and *varied* and *changeable* variables, which are those that can be affected by watching and making sense of films. Fixed variables include gender, age, and personality (some people would argue that personality and intellect can be changed but here I've contrasted with more obvious changeable variables), all of which emerged clearly from the data as affecting the sense-making activities. Despite all the interviewees being Chinese, cultural background (which includes nationality and race) was also seen to have a significant effect on sense-making process, particularly through the interviews extracts from WZT (chapter seven, Q.6.3.1.7) who came from a Tu minority background. Intellect has been added to the list of fixed variables, although it did not emerge clearly from the data. All of the interviewees had achieved admittance to good Chinese universities, and so there was not a large range of intellectual capability. However, it is reasonable to expect intellectual capability and personality do influence making sense of foreign films (including TV series).

In terms of changeable variables relating to the viewer, knowledge, attitudes, life experience and philosophy of life all emerged clearly from the data. In terms of making sense of foreign films, knowledge, attitudes and life experience can be divided into different levels related to local and foreign people, as shown in the figure. Each individual has different knowledge of, attitudes to, and life experience of self, significant local others (such as family and close friends), local groups containing self (such as group of same sex peers), local groups not containing self (e.g. Chinese parents), and local people in general (e.g. Chinese people). They also have different knowledge of, attitudes to, and life experience of foreign individuals (such as International students studying in China), groups of foreigners (e.g. foreign English teachers or Japanese) and foreign people in general.

Skills and abilities are also changeable variables relating to the viewer. The relevant skills and abilities are listed in the box at the bottom right of Fig. 8.2.

Listening skills, vocabulary and understanding the meaning (both explicit and hidden) emerged from the data discussed in section 6.1.1, which relates to sense-making activities in the category 'comprehending the plot'. These skills are not only important to sense-making activities, but they are also the ones Chinese college students would like to improve as a result of watching foreign films. In terms of Byram's (1997) model of intercultural communicative competence (Fig. 3.6), these skills are part of linguistic competence (vocabulary and listening skills) and socio-linguistic competence (understanding meaning both explicit and hidden).

Intercultural skills and abilities (in the current new model) also both influence sense-making activities and can be affected by those activities. Following the terms used by Byram, Nichols and Stevens (2001), one category of these skills is called 'skills of interpreting and relating', which is the skill to interpret documents (including films) from another culture and explain them, and to relate them to documents and events from one's own culture. The examples presented in sections 6.4.1, 6.4.2, 6.4.3 and 6.4.4 of 're-contextualising' activities (in chapter six) demonstrate this type of skill (at varying skill levels). Another category is 'skills of discovery', which means the ability to acquire new knowledge of a culture and cultural practices. One of the interviewees appeared to have skills of this kind. She indicated that, after watching a film that she likes, if there is anything she does not understand she would normally search for more information on the same subject, such as history of a foreign country. Having gained more knowledge on the subject, she would watch the film again to gain a better understanding of the film. Finally, using Byram's (2009) definition, 'critical cultural awareness' refers to the ability to evaluate perspectives, practices and products in one's own and other cultures and countries critically and objectively. The data contained few examples of this ability, but a female Chinese college student JT (Q.6.2.3.8) in section 6.2.3, chapter indicated that, unlike other students, she was able to identify differences in parenting styles between Chinese and Western parents objectively without judging either Chinese or Western parents.

8.1.4 Environmental Variables

In addition to variables related to the viewer, there are also environmental variables related to the environment in which the viewer views the film and conducts the sense making activities. The influence of peers on the sense-making activities of individual students emerged clearly from the data (e.g. Q.6.2.3.7). During the semi-structured interviews, there were also occasions when my questions prompted students to perform sense-making activities that they wouldn't have otherwise undertaken. The film may then have affected them in ways that otherwise would not have been the case. In the model the influence of peers and seniors has been grouped together in

the variable 'influence of others'. For example, after viewing the clip *Prepare for launch*⁶⁸ PWB (Q.6.3.1.3) initially indicates that he does not think there are any differences between Chinese girls and British girls in terms of preparation before going out for a date with boyfriend. However, having been prompted by my question, he thought about it more and pointed out some differences between his perception of Chinese girls and the fictional character Bridget.

The data showed that Chinese college students watch films in various environments, including in cinemas, in dorms by themselves or with others, and in the English language classroom. The atmosphere of the environment (meaning generally the mood and emotions of the people watching) will also affect the outcome of sense-making activities. The data contains an example of a group of Chinese college students comparing each other and classmates with *Forrest Gump* in a light-hearted manner (Q.6.3.1.13). The mood of the group will most likely have affected the outcomes of the sense-making activity.

8.1.5 Sense-Making Activities

As discussed in chapter six, in the process of making sense of foreign films and TV series, audiences conduct five types of sense-making activities, 'comprehending the plot', 'perceiving as realistic', 'compare: identifying differences', 'compare: identifying similarities', and 're-contextualizing'.

'Comprehending the plot' has to do with audience's understanding of where and what happens and who is/are involved in the story. During the data analysis the outcome of this type of sense-making activity was found to be most affected by the students' English language skills (vocabulary, listening skills, understanding meaning), existing knowledge regarding the subject matter and people like the characters, whether or not the student had watched the film before (part of life experience and knowledge), and whether or not the subject matter was familiar to the student (also part of life experience and knowledge). The interpretation of the plot and characters formed by the students both influences and is affected by the other types of sense-making activities.

'Perceiving as realistic' has to do with the extent to which the audience believes the film reflects reality in its cultural context (the target culture). There are a number of variables influencing perceiving a film as realistic which relate to the film being viewed, rather than the viewer or the environment. In the model these variables are taken to be properties of the foreign media and are not included in the model as separate variables, but form part of the foreign media box. These

⁶⁸ Prepare for launch: a clip chosen from the British film *Bridge Jones's Diary* (2001). In the clip, Bridget needs to prepare for an important social occasion at her work, at which Bridget plans to entice Daniel, the man she fancies and hopes to date. Bridget turns to her close friends, Jude, Sharon and Tom, to ask for help. The clip also includes Bridget's preparation in her bedroom, such as choosing which underwear to wear, practicing her introductory speech, etc.

variables include the genre of the film, having a convincing narrative, having quality acting, and having been adapted from a true story. However, viewer variables were also found to influence 'perceiving as realistic'. The Chinese students interviewed valued authority a lot, and placed value on films being produced by native English speakers, having won awards and having good *reviews*. This relates to the variable 'cultural background'. The degree to which a film was thought to have a convincing narrative and quality acting was affected by knowledge, attitudes and life experience related to the people and subject matter in the film. Students were also found to fall into three categories (*believer, doubter* and *sceptic*) influenced by the variables 'personality' and 'philosophy of life' and other variables. Because of the complex interaction of all the variables, individual student's perception of to what extent foreign films are reliable representations of reality in general and individual films was found to vary greatly. Perceiving a film as realistic was found to both affect and be affected by the other types of sense-making activities, and to influence the effect the film and sense-making activities had on the changeable viewer variables.

'Identifying differences' and 'identifying similarities' are both the results of comparisons conducted on various levels. Three levels were observed in the study. The first level is viewers compare foreign fictional characters with individuals, including themselves and/or significant others. The second level refers to viewers comparing foreign fictional characters with an equivalent generalized group of local people, containing or not containing self. The third level deals with viewers comparing people represented by the fictional characters with local people in general. Here, 'people represented by characters' includes both groups of foreign people and foreign people in general. These levels mirror the levels of knowledge, attitudes and life experience listed in the box at the bottom left of Fig. 8.2, and indeed knowledge, attitudes and life experience were found to be the main viewer variables effecting and affected by this type of sense-making activity. In addition, gender was found to be an important factor in terms of identifying similarity with self and groups containing self.

'Re-contextualizing' was the most sophisticated type of sense-making activity observed in this study. The activity of re-contextualizing is closely related to Byram, Nichols and Stevens (2001) 'skills of interpreting and relating' which is the skill to interpret documents (including films) from another culture and explain them, and to relate them to documents and events from one's own culture. Re-contextualizing was observed on four levels in this study: re-contextualizing fictional character(s) in personal context; re-contextualizing fictional character(s) in Chinese context; re-contextualizing self in fictional context; and re-contextualizing Chinese people in general in the fictional context. However, re-contextualization could take place at all the levels listed in the Levels box in the bottom left of Fig. 8.2. The variables significantly influencing and affected by this

type of sense-making activity are also knowledge, attitudes and life experience, together with the skills of interpreting/relating.

This classification of sense-making activities undertaken by viewers of foreign films presented here is unique, and there are no comparable classifications in the literature with which these categories could be compared.

8.1.6 Effects

The questionnaire results reported in chapter five indicated that Chinese college students believed films produced in the U.K. and U.S.A. were the main resource from which they learnt about the people and cultures of these countries, so clearly watching and making sense of films affects knowledge. As watching a film is a life experience, watching and making sense of films influences life experience.

The semi-structured interviews indicated that improving English skills motivated the students to watch films, so it is reasonable to assume that these skills are affected by film-viewing, although the current study did not gather data proving that these skills were actually improved. English skills were, however, found to be important for comprehending the plot, and the exercise of skills is normally thought to improve them. Likewise, the intercultural skills defined in the model are exercised in the sense making activities, and perhaps could be improved through film watching.

In addition to the effects identified from chapter five, four other categories of effects were identified through analysis of the data collect in the semi-structured interviews (chapter seven): reinforcement/refinement of understanding of and attitudes to self/significant local other; reinforcement/refinement of understanding of and attitudes to generalized groups of Chinese people; reinforcement/refinement/challenge of understanding of and attitudes to generalized groups of foreign people represented by the fictional characters; and reinforcement/refinement of/challenge to philosophy of life. In terms of the variables in the model, understanding refers to knowledge

While interpretation of the plot and characters may directly affect a viewer's knowledge of and attitudes towards foreign people, changes to the knowledge of and attitudes towards self and local people also come through the sense-making activities directly. Consequently in the model (Fig. 8.2) there are two 'effects' arrows indicating that both the sense-making activities and the interpretation of the plot and characters affect the changeable viewer variables.

The 'input' arrows in the model show that the media, the viewer variables (both fixed and changeable) and the environmental variables are inputs to the sense-making activities, while the

'output' arrow indicates that 'interpretation of the plot and characters' (or in other words the sense or meaning of the film) is the output of sense-making process.

Referring back to the review of media effects literature (section 3.1.2), Klapper's (1960) three types of effects have all been observed and captured in the model: *conversion* (here the result of challenge to understanding and attitudes), *minor change* (here called refinement), and *reinforcement*. In terms of McQuail's (2005) classification into *intended change* and *unintended change*, all of the effects observed and incorporated into the model are clearly unintended by the producers of the media. McQuail's levels of effect, *individual*, *society*, *institution* and *culture* map quite well onto the levels defined in the new model, although McQuail (2005) does not consider the distinction between local and foreign. The new model contains all three groups of effects (Hovland et al 1949): cognitive (effect on knowledge); affective (effect on attitudes); and behavioural (effect on philosophy of life). Many of the audience variables identified by Krugman (1965) and Perse (2001) have been incorporated into the model, including individual differences, level of prior knowledge, and whether or not the plot makes sense. In terms of the distinction between short-term and long-term effects (Golding, 1981), short-term effects on the emotions of the audience have only been included in the model as an environment variable (atmosphere). From an educational point of view only long-term effects are of interest.

8.1.7 Implications of the Model

Although the new model is developed from the empirical findings of current study in the Chinese context, which aimed to unveil how Chinese college students make sense of films and TV series produced in the U.K. and the U.S.A, it should be applicable to foreign media in general, including films, TV series, radios, newspaper, novels etc., wherever the media are 'foreign' to the viewer in the sense of being the product of a foreign culture.

From an educational perspective, the model shows:

- By watching and making sense of foreign films the knowledge of and attitudes of students towards foreign people, themselves, local people and cultures can be changed, and some of their linguistic, sociolinguistic and intercultural skills can potentially be improved.
- The teacher can influence the effects of the sense-making activities (both directly through the environment variables and through selection of appropriate media) in order to encourage development of the knowledge and attitudes, and some of the skills, which make up intercultural communicative competence (Byram, 1997).

- The sense-making activities can be arranged as either individual or small group class activities where students can also practice some of the two-way communication skills (e.g. discourse competence, social-linguistic competence) which are not directly affected by viewing and making sense of media.
- In constructing classroom activities around the sense-making activities, teachers should be aware of the individual differences reflected in the viewer variables and environmental variables (e.g. group dynamics).

8.2 Current Use of Foreign Films and TV Series in ELT in China

To answer Research Question 5, which aims at researching the current status of using foreign films in ELT, section 3.3 reviewed the literature on using foreign films and TV series in English language teaching in both Chinese and non-Chinese contexts. To provide supplementary findings, in particular with the current use of foreign films in ELT in the Chinese context, this section will report the empirical findings from semi-structured interviews regarding how Chinese college English language teachers have been using foreign films and TV series in their language class, based on Chinese college students' own experiences.

Among twenty interviewees, fourteen students indicated their English teachers had used the films in the class. Several approaches to using films in English language class by teachers were described by students based on their own personal experience.

- **Relaxation and film appreciation**

One common approach among Chinese college English teachers is to show part of a film or an episode of TV series (e.g. *Friends*) during 10-minute breaks between lessons⁶⁹. This is indicated by the following exemplary text extracts.

(Q.8.2.1)

GH: 我们现在的老师有时候在课间有 10 分钟时间嘛, 以前老师没有放. 但是他一节课肯定放不完, 是连着放的, 下节课接着放. [...]

Interviewer: 有人看?

GH: 有人看, 挺喜欢看的. [...]

Interviewer: 那你们这些老师用电影, 也就放过电影, 放完干什么?

GH: 放完就完了, 紧接着讲课啊。

English translation:

GH: Our current teacher sometimes lets us watch films during the 10-minute break between lessons. Our previous teacher didn't do so. But we cannot watch the whole film during one lesson break. The teacher will keep showing the same film during the next break.

⁶⁹ Break between lessons: In Chinese universities, usually there is a 10-minute break in the middle of one class. This means, there are two lessons in each class.

Interviewer: Are there any students to watch?

GH: There are. It is enjoyable to watch.

Interviewer: Then does your teacher organize any follow-up activities after viewing?

GH: Only lets us watch the film. After viewing, (teacher) has to continue the lesson.

(Q.8.2.2)

Interviewer: 你们老师放电影的主要方式是什么?

GMX: 就是课余时间给我们放, 放着好玩。

Interviewer: 那你们老师有没有让你们去学习一下里面的内容?

GMX: 没有。他就是给我们放 [...]

English translation:

Interviewer: What is your teacher's approach of using films?

GMX: It's just for fun. S/he lets us watch during break between lessons.

Interviewer: Did your teacher help you study the film itself?

GMX: No. S/he merely let us watch the films.

(Q.8.2.3)

LAQ: 放过。就是我们每次课间的时候, [...]

Interviewer: 你们老师放片子的目的是什么?

LAQ: 他主要可能是想让我们就感受一下口语说话的那个感觉。

Interviewer: 放完片子还有什么活动吗?

LAQ: 完了就完了。

English translation:

LAQ: (Our teacher) has shown films to us, during breaks between lessons. [...]

Interviewer: What are your teachers' purposes of showing you the film?

LAQ: Perhaps s/he wants us to experience the spoken language in the film.

Interviewer: Does your teacher organize any follow-up activities after viewing the film?

LAQ: No activities. Only watching films.

Students were not informed of the educational purpose (if the teacher had any in mind) of film-viewing. Students' comments indicate the possible purpose of this approach is for relaxation, exposure of authentic English language, entertainment and film appreciation. There were no follow-up activities or assignments after viewing.

- **Improve listening skills**

Another common approach is to use film-viewing to try to help students' improve their English listening skills. WZT's English teacher is one of a number of teachers who were reported to use films to try to help their students improve listening skills. Let us look at an exemplary text extract below.

(Q.8.2.4)

Interviewer: 我知道你们老师给你们放过电影, 他是放了就放了, 还是有没有什么活动啊?

WZT: 没有活动。他就是讲解一下, 他给我们放电影, 主要想给我们练习听力。想让我们练听力, 他就把整个的字幕去掉了, 然后我就不想看了, 因为字幕去掉了我就整个电影理解不了了, 理解不了了我就根本不想看了, 他把字幕加上了我就根本练不了听力了, 我就直接盯着那个字幕, 它演到哪里就看到哪。然

后他演完了以后，也不会对国家啊什么的介绍，他顶多说，诶呀，你们就练一下听力啊，这个人物挺搞笑的什么的。就这样。

[...]

Interviewer: 那他主要还是放电影，然后练习听力，没什么活动？

WZT: 恩。也没有什么活动，没搞过。有时候时间的关系，没放完，然后顶多他对后面的故事情节做个概述。他就是说了一下，简单介绍一下。

[...]

Interviewer: 那你觉得你们老师给你们放电影什么的有帮助吗？

WZT: 诶呀说实话我觉得效果不大。主要是看的一头雾水，也不理解，听也听不太懂。看完了就完了。但是我们都喜欢看。

English translation:

Interviewer: You told me that your teacher use films. Does he organize any activities after viewing the film?

WZT: No activities. He only explains a bit, saying he will show us a film, he mainly wants to help us practise listening skills. Let us practise listening skills. He got rid of all subtitles. Then I didn't want to watch because I couldn't understand the whole film. I don't want to watch if I cannot understand the film. I cannot practise listening skills if he added subtitles because I would stare at the subtitles. After viewing, teacher did not introduce anything about that country. At most, he would say, oh, this character is funny, you can practise listening skills. That's it.

[...]

Interviewer: In addition to showing you film and helping you practise listening skills, does he organize any activities?

WZT: Well, no activities, he never organized any. Sometimes he couldn't show the whole film due to time limitation. He would tell us the gist of the rest of the film. He simply mentioned it, briefly introduced it.

[...]

Interviewer: Do you find what your teacher did was helpful, such as watching film, helping you practise listening skills?

WZT: To tell the truth, there is very little help. It's mainly because I was confused, didn't understand the film and the language. That's it after watching it. But we all love watching films.

It seems that teachers simply let the students watch the films without subtitles and assume students' listening skill will improve automatically as result of watching the film. However, they seem to be unaware of the fact that students encounter great difficulty in understanding the film without subtitles, as this study has discovered. This study has also shown clearly that unless they are able to understand the film, students will lose motivation to keep watching the film, and will end up feeling confused and discouraged. This example shows a teacher engaging in an inefficient way of using resource and time without achieving their purpose of improving students' listening skills. It is notable that no pre-viewing or follow-up activities are organized by the teacher.

- **Improve pronunciation**

Some teachers attempt to use films to help students improve their pronunciation. However, in the same way as when using films to try to improve students' listening skills, the common 'teaching method' is to show the film without any subtitles without any organised pre-viewing or

follow-up activities. Teachers seem to share a common assumption that students will automatically improve their pronunciation simply by watching the films. For example,

(Q.8.2.5)

PP: 这是我们上英语课老师放的, 因为我们英语老师是特别喜欢英音, 她说这部片子 (*The Queen*) 英音特别好, 然后就给我们放了。[...] 她上课就是总放电影, 就是让我们多看这个多了解那边的文化。

Interviewer: 她的教学方法是什么?

PP: 她也没...就不象你说的那种, 靠这种方法来教学, 她就是...比如说学课文学时间长了, 累了我放 10 分钟, 你们看一下, 多看一些对你们有好处。只是限于这么一点, 但是她不会去讲, 你从这个学到什么得到什么, 她不会去讲这些。她只是就是给你设计一下, 你要是自己喜欢的话你回去再看他不会给你在课上讲这些东西。

English translation:

PP: This (showing films to us during lessons) is something our English teacher does. Because our English teacher likes the British accent a lot, she said the British accent in this film (*The Queen*) is very good, so she showed us the film. [...] She often shows us films in the class. Her purpose is to let us learn more about culture on the other side.

Interviewer: What is her teaching method?

PP: She doesn't use films to teach. She simply For example after working on articles for a long period of time, we are tired, and she will show us film for 10-minutes. (She said) watching more films is helpful for you. This is the only thing she does. And she didn't teach us, what you can learn from this, etc. She didn't mention these. She only plays some of the film, and if you like the film you can finish watching film after class. She doesn't discuss anything about film in class.

- **Learn cultural knowledge**

As PP's comments above also indicate, another reason Chinese teachers give for using films in the English language class is to help students learn more knowledge about the target culture. However, like the other teachers, PP's teacher simply shows the films without any further instruction, pre-viewing activities or follow-up activities. It seems that the teacher assumes that by watching foreign films, students will automatically learn more about the foreign culture. However, the empirical findings illustrated in chapter six indicate that making sense of foreign film is never a linear process like many teachers, such as PP's teacher, appear to assume. This study has shown it is a complex and dynamic process, and hence the type of approach clearly needs to be improved.

Several reasons for using foreign films in English language class have been identified among the teachers of participants of the semi-structured interviews. Some language teachers use films for relaxation or film-appreciation. Some language teachers use films to help learners improve their listening skills, pronunciation and knowledge of target culture. However, although the reasons and intentions vary, the teaching 'approach' is the same in each case. The English language teachers show either whole or part of the film or TV series in the college classroom setting

without any pre-viewing or post-viewing activities, assuming that the students will benefit in the way the teachers have in mind.

In addition to this approach, some teachers use film to provide a topic for other activities. Although most of the students indicated that their teachers do not organize any pre-viewing instruction or follow-up activities after film-viewing, one student, SY, indicated that their teacher had asked students to write a film-review after watching the film *Lost in Translation*. SY's teacher emphasized that there was no need for students to watch the film again, but simply to go ahead and write about anything the students felt and wanted to write about. However, due to the fact that teacher did not show any subtitles, SY could not understand the film, and ended up confused. The teacher did not provide any feedback or follow-up after students submitted their film-reviews. At the time of the interview, SY indicated that she was still confused by that assignment. Unless the educational purpose SY's teacher had in his/her mind was simply to give students a topic for a written English assignment, it seems unlikely the teacher's purpose was achieved.

- **Are students satisfied?**

Now, let us look at how students feel about their teachers' approaches.

(Q.8.2.6)

Interviewer: 你们老师怎么用?

JT: 就放吧。

TXH: 没说什么。

Interviewer: 什么时候给你们放?

TXH: 上课放。

JT: 上课放。[...] 放了那个我没太看懂。

TXH: 因为全是英文的, 然后又没有中文字幕。

JT: 全是英文字幕, 然后我做在后面看不到字幕, 然后我不知道他在说什么。他好象, 不是为了用电影去教学, 仅仅是, 因为上次的和环保有关系。他是为了引入题目。

TXH: 但是他也没有再谈起放的这个片子了。也没有再怎么谈论。

Interviewer: 那他全放还是就放一点?

JT: 放到下课。就是能放多少就放多少。其实上英语课就是这么无聊。

TXH: 对啊, 我也觉得挺无聊的。

JT: 相当无聊。

TXH: [...] 现在的教学太 boring 了。

JT: 很枯燥的。

English translation:

Interviewer: How does your teacher use films?

JT: Just let us watch.

TXH: Didn't say anything.

Interviewer: When does your teacher let you watch?

TXH: In the lesson.

JT: In the lesson. [...] I didn't quite understand.

TXH: Because the soundtrack is all in English without any Chinese subtitles.

JT: Only English subtitles. I couldn't see the subtitles because I sat at the far back. I didn't understand what s/he's talking about. S/he didn't seem to use films to teach us anything. That film was about environment. S/he only used it to lead in the topic.

TXH: And s/he didn't play this film again and didn't mention about it again.

Interviewer: Did s/he show you whole film or a bit of a film?

JT: S/he let us watch the film till the end of the lesson and stopped wherever the film was. Actually, English lessons are always boring like this.

TXH: Yah, I also feel bored.

JT: Very boring.

TXHL [...] Teaching methods are too boring.

JT: Very uninteresting.

(Q.8.2.7)

Interviewer: 你们老师是如何用电影的呢? 组织其他的活动吗? 还是只是放电影?

GW: 没什么其他活动。挺单调的。

Interviewer: 那你们老师怎么选择电影的? 那你们要看什么就看什么, 还是老师...?

GW: 他没有问过我们。他一般都选择那些句子比较浅显的, 不是特别深奥的, 动画片放的特别多。Disney 的动画片放的特别多。[...] 还有比经典的海上钢琴师, 阿甘正传啊, 勇敢的心, 与狼刚舞, 就是比较经典的。不是特别经典就是特别幼稚的我觉得。就没有一个特别贴近我们生活的。 [...]

English translation:

Interviewer: How does your teacher use films? Does s/he organize any activities? Or just let you watch the films?

GW: No other activities. Pretty boring.

Interviewer: How does your teacher choose film? Do you get to watch whatever you want or it's up to the teacher...?

GW: S/he never asked us. S/he usually chooses those that have relatively more simple sentences, not too difficult to understand. A lot of cartoons. S/he shows a lot of Disney cartoons. [...] and some classic films, like, *Pianist, Forrest Gump, Brave Heart, Dances with Wolves*, those classic ones. They are either very classic ones or childish ones. None of them are close to our lives.

The exemplary text extracts above indicate a common negative attitude among interviewees towards their teachers' methods of using films in English language class. First, due to the language difficulty, the students are not able to understand the film without the assistance of subtitles. This dramatically reduces students' motivation to keeping watching and paying attention to the films. In addition, feeling confused leads to a lack of sense of achievement and to discouragement. Secondly, as the final underlined sentence from GW's comments indicates, the films chosen by teachers do not always fit with the students' interests. According to GW, films that are closer to the students' lives would be more attractive.

Comparing what is happening in the English classrooms of the students participating in this study (which appears to be very thin) with the literature that has been written by English instructors in the Chinese context, there is a huge gap between what is proclaimed in the literature and what is really happening.

8.3 Critical Review of Literature Based on Findings

This section will revisit and review critically the literature addressing the use foreign films and TV series in both the non-Chinese and Chinese contexts (literature review, section 3.3), using the empirical findings of current study. In doing so, the pros and cons of the approaches presented in the existing literature will be discussed (bearing in mind that no evidence has been found that these approaches are actually being used in practise in the Chinese content). As usual, the word 'films' will be used to represent both films and TV series.

- **Why films?**

The findings of this study confirm the main reason for using films in the English language classroom suggested by the literature in both Chinese and non-Chinese contexts (e.g. Dou and Wang 2001; Bo 2006a; Huang 2009, Sherman 2003, Hill 1999), which is that films are motivating and entertaining. Films are potentially good for teaching, as they are attention-catching, and it is easy to have discussion on various topics from the films, as the semi-structured interviews have shown. In addition, the findings emphasise that both full-length films and clip from films can be so powerful that they stimulate rich and dynamic cognitive and affective responses from students. This further indicates the audio-visual advantages and potential of using films in an educational setting. Also, words such as direct (直接), quick (快), 综合 (comprehensive), altogether at one (一次性) (chapter 5, section 5.2 GH Q.5.2.1) used by students to demonstrate the advantages of films over other resources, such as textbooks (dry '干的', not flexible '死的', sticking to the box '一条一条的', Q.5.2.6 in chapter five) indicate that the fact that films can stimulate students' audio, visual and cognitive senses at once makes them stand out. Students love films!

However, empirical findings cast doubt on another reason suggested by the literature. In the Chinese context many teachers perceive foreign films as a realistic representation of the target culture, or a mirror on Western Culture (e.g. Chen 2007b; Yang 2009b; Zhou 2009a; Zhang 2009b). However, three types of viewers emerged from the data, *believers*, *doubters* and *sceptics*. Those teachers who believe films reflect the reality of the target culture seem to fall into the category of *believers*, who tend to take films at their face value. However, the findings presented in chapter six clearly indicate this view is inadequate. Perhaps surprisingly, some students are more critical when making sense of foreign films than language teachers who have published scholarly articles on the subject. It is important to note that those teachers perceiving films as realistic directly affects their teaching approach, choice of films, and activities, and also, their knowledge of and attitudes to target cultures and perhaps towards themselves. Such teachers clearly will not be able to make the most effective use of foreign films.

With regard to another main reason for using foreign films in ELT provided by literature in the non-Chinese context, the empirical findings confirm some language instructors' suggestions, such as Stempleski and Arcario (1992) view that films show how native speakers of English look at themselves, and Holden's view that foreign films can be seen as cultural products for entertainment, instead of as realistic representations of reality. In addition, Macdonald and Macdonald's (1999) view that films providing countless examples of problematical behaviour, conflicts and crushes, private lifestyles etc which cannot be provided by other means, seem to be reasonable, as long as films are perceived as cultural produce rather than the mirror of reality some language instructors assume. However, comparatively, Sherman's (2003) perceptions on films as 'window on English language culture' and Aiex's (1988) views that films is the 'second best thing after living and studying in the target cultural context', and Wood's (1992) proposal of films provide multicultural and multilingual oasis to language learners, seem to be rather too general and express the same view as the Chinese scholars referenced above.

- **What are films used for?**

Literature indicates that, both in the Chinese context and non-Chinese context, one main purpose of using films in ELT classroom setting is to improve students' linguistic competence (e.g. Dou and Wang 2001; Zhao 2002; Zhou 2009; Visscher, 1990; Rebhorn 1987; Stempleski 2001).

In the Chinese context, another approach is to help learners gain more knowledge of the target culture and knowledge of the cultural differences between local and target cultures (e.g. Cui 2006; Fang and Li 2008; Zhou 2009a). Although there is some discussion in the literature (e.g. Xiao 2009) about using films to develop Intercultural Communicative Competence, as discussed in the literature review, this seems to be interpreted as the combination of linguistic competence and cultural knowledge (including knowledge of cultural differences) and is different from the notion of intercultural communicative competence developed by Byram (1997).

In the non-Chinese context, films also have been suggested to help develop learners' competence and skills for effective two-way communication (e.g. Holden 2000, Ryan 1998). In addition, Conlon (1991) proposed using the film *Witness* to help language learners (who were studying in the States) improve their awareness of American cultural and justice system. Although Conlon did acknowledge the fact that films are a form of art, the actual lesson plan and classroom activities Conlon provides indicate lack of criticality in terms of to what extent the film reflects the reality in the states. In addition, most of the tasks focus on analysis of fictional characters. The potential richness of students' responses when allowed more freedom, as indicated by current study, is ignored. Wood (1997) used films to lead to intercultural insights and, although like Conlon the

dynamic meanings produced by students as a result of making sense of film are ignored, Wood did point out the need to stop students from over-generalizing. Last but not least, Corbett's (2003) suggestion that intercultural skills of interpretation and critical cultural awareness can be developed by analysing the cultural text (film) further indicates that, in terms of using foreign films in ELT, the common 'hole' that language instructors fail to recognize is that rich, dynamic and complex meanings can be produced by the students utilizing their own experience, knowledge, attitudes etc.

Empirical findings (chapter six) on the sense-making activities clearly illustrate the complexity of making sense of foreign films. As result of film-viewing, students' knowledge of and attitudes to peoples and cultures on various levels (as shown in the model) and philosophy of life can be changed/reinforced/refined. Hence, it can be argued that foreign films have much more potential and value in the English language classroom than the current literature presents. As the model proposed here indicates, foreign films can be used to improve many of the components of intercultural communicative competence (ICC) (Byram, 1997). Language teachers can help improve learners' ICC by choice of film and by prescribing or influencing the environmental variables (i.e. interaction of students with teacher, interaction between students, classroom atmosphere), making use of activities developed around the sense-making of foreign films. More detailed recommendations on how teachers can use films to improve ICC will be presented in section 8.4.

In addition, findings suggest that films also have the potential of raising students' deeply felt moral issues, such as social hierarchy (WZT Q.6.3.1.6) and views on homosexuality (GW Q.6.4.1.1). All of these are issues teachers and students can discuss in the class from an intercultural perspective.

- **Selection criteria**

In the literature, some Chinese instructors suggest using a film's suitability to the 'learners' English proficiency' as one of the criteria for choosing foreign films for use in the English language classroom (e.g. Fang 2008; You 2009). This approach is supported by the empirical findings. In particular the findings concerned with the first category of sense-making activities, 'comprehending the plot', clearly show that Chinese college students encounter great language difficulties when watching foreign films. Data analysis indicates that, for Chinese college students who are not majoring in English, lack of relevant background knowledge, unfamiliarity with the subject, and language-intense dialogues are three main challenges for the students.

However, Bo's (2006a) and Huang's (2009) suggestions about using cartoons for lower level students are questionable, because cartoon films are not necessarily easier to understand. As Lan (2009) observed, the language in cartoons, in particular the pronunciation and intonation, tends to be exaggerated. Although this study only identified one instance of a teacher making use of cartoons (Q 8.2.1.7), the student was not positive.

In addition, there is some disagreement in the literature in terms of whether to choose films with a large amount of dialogue (Lu 2009, Yang 2009a) or with simple dialogue (Ma 2009, Zhao 2002). The findings of this study indicate that films with too much fast dialogue are not advisable, as, even with Chinese subtitles, students will struggle to follow. On the other hand, simple dialogue may be associated with childish films which do not interest the student and have limited value for developing knowledge and attitudes towards the target culture, and so these are also not advisable. The subject matter of the film should be considered together with the complexity of the language. As discussed in chapter six in the section about comprehending the plot, the clip *Shop for gun* appeared to be the most difficult for students to comprehend, even with Chinese subtitles, because it has very long and language-intense dialogues without many body gestures to help, and students seem to lack of knowledge on the detail of racial issues in America. The clip *Step off* from *School of Rock* was a lot easier for students to comprehend, even without Chinese subtitles, because it is about teachers and students, a subject they are familiar with, and the clip has a rich context and body gestures to support the dialogue.

In addition to language related criteria, some teachers prefer to choose *award-winning* films (Yang 2009b), films with *interesting plots* (Chen 2007b, Fang and Li, 2008), and films that are *close to life* (Bo, 2006a, Chen 2007b). The empirical findings of this study support these suggestions, because data analysis indicates that films with above features are very popular among students. In terms of the criteria of *close-to-life*, first, findings indicate that close-to-life is one of the variables which affect whether or not students perceive a film as realistic or not. For example, student JT lost interest in watching *Prison Break* after the series became more and more unrealistic, although she loved watching the first season (Q.6.5.2.3 in chapter six). When films are perceived by students as unrealistic, they tend to lose interest in watching them. However, even if a teacher perceives a film as close to life, data indicates that students may not share the same view. The teacher's own knowledge of and attitudes to the target culture, together with the other variables included in the model, will influence their perception. Niu et al (2008) advocates choosing films that reflect reality. While this appears to be an appropriate goal, in practice teachers may struggle to achieve it.

Also, the concept of 'correctness' among Chinese teachers is common in the literature. You (2009) suggests choosing films that can help students develop a 'correct' philosophy of life and films that can help students interpret western culture from a 'correct' perspective. However, such films are unlikely to be of interest to students, who, as the data has shown, have access to a wide range of foreign films through various channels and have their own view of the notion of 'correctness'. Secondly, this approach does not support the notion of intercultural competence, which emphasises the ability to decentre and to understand issues and situations from various perspectives without rushing to judging prematurely the correctness of any particular perspective, and exercising critical cultural awareness.

Last but not least, although there is limited literature available in the non-Chinese context, the criteria proposed by Sherman (2003), such as films should be popular, interesting to learners, visually attractive, have a subject suitable to learners and be linguistically easy, are confirmed by the current study.

- **How to use films?**

The findings presented in this thesis clearly indicate that both full-length film and carefully chosen clips from films not only can engage students, but also stimulate rich responses. In particular, with full-length films, some of the students still remember a film very clearly many years after watching it. This indicates the how powerful these films are. Although both full-length films and clips from films have been suggested in the literature by the teachers, the value which can be gained has been under-estimated. Tang (2006) recommends the use of full-length films just so that the students understand the story. Zhang (2009) and Tang (2006) recommend using clips, but mainly for intensive and extensive language study. In the non-Chinese context, there has been debate about whether to use full-length-film or clips. However, from this study it is clear that both full-length films and film clips have much more educational value than has been recognised previously.

Table 3.4 in the literature review presented a range of pre-viewing, viewing and post-viewing activities recommended by Chinese scholars. Most of these activities are designed to enhance students' comprehension and development of linguistic competence. However, this study found only one of these activities actually being used in the classroom, the post-viewing film review. Unfortunately the students involved were completely confused about the purpose of the activity.

With regard to the non-Chinese context, Table 3.1 in the literature review presents a range of commonly used activities arranged by pre-viewing, viewing and post-viewing stages. Most of the activities are designed with two common purposes, development of linguistic competence and

enhancement of comprehension. In addition, although only a limited number of activities which are culturally-related have been proposed, Sherman's (2003) *Over the top* (students judge the realism of film) and *Picture it* (challenge stereotype) activities appear to be consistent with sense-making activities identified in this study.

To sum up, the current section has critically reviewed the literature on using films in English language teaching both in the Chinese and non-Chinese contexts in light of the data findings, and compared the recommended approaches with the current teaching approaches by college English teachers in China. It is clear that although teachers do use films in the ELT classroom, they lack awareness of the activities already available in the literature to achieve value from these films. Appreciation of the value of films from an intercultural perspective, and in particular, to help development students' intercultural communicative competence (ICC), is absent both from the literature and from current practise.

Having presented the current approach of using films in ELT in the Chinese context and the critically reviewed the literature on using films in ELT both in the Chinese and non-Chinese contexts by using empirical findings, the following section will provide more detailed teaching suggestions for using foreign films in English language teaching.

8.4 Using Foreign Films in ELT: An Intercultural Approach

This section suggests an *intercultural approach* to using foreign films (including both films and TV series) in college level English language teaching based on the Foreign Media Sense-Making (FMSM) model described in section 8.1. The approach is called 'intercultural' because the ultimate goal of this approach is to help college students develop intercultural communicative competence (ICC), a widely recognized notion developed by Byram (1997). Although the study that led to the development of the model was conducted in China, it is believed that the model and this intercultural approach to using films in the English language (or indeed any second language) classroom can be applied more widely. However, the particular challenges for applying this approach in the Chinese context will be discussed, together with the advantages gained in applying the approach in an ESL classroom in the U.S.A. or the U.K.

8.4.1 Intercultural Communicative Competence

As discussed in section 3.2 of the literature, Intercultural Communicative Competence is a model of the competencies that enable a person engage successfully in intercultural communication and interaction (Byram, 1997). Intercultural Communicative Competence includes four sub-competences: *linguistic competence*, *socio-linguistic competence*, *discourse competence* and *intercultural competence*. A person who is interculturally competent is one who is able to

“decentre and take up the others’ perspective on their own culture, anticipating, and where possible resolving, dysfunctions in communication and behaviour” (Byram, 1997:42). In broad terms the requirements for each of the sub-competencies of Intercultural Communicative Competence can be broken down into the categories of knowledge, attitudes, skills and abilities. To align with the new model, all the requirements for ICC can be listed together under these categories as follows.

- **Knowledge**

ICC requires knowledge of the social groups, products and practices at each of the levels defined in the ‘Levels’ box of Fig. 8.2, and knowledge of self. Film-viewing can assist greatly with knowledge of the foreign culture. Reflection on the similarities and differences between the foreign culture and the local culture during sense-making activities can assist in developing a de-centred knowledge of the local culture, and also of oneself.

- **Attitudes**

ICC requires an attitude of curiosity and openness to self and to others, again at all the levels defined in the ‘Levels’ box of Fig. 8.2. Sense-making activities during film-viewing, particularly comparison and re-contextualization activities, can allow students to challenge existing (perhaps negative, positive, or otherwise judgemental) attitudes towards foreign people, local people and self.

- **Skills and abilities**

A number of the skills and abilities required for ICC are listed in the ‘Skills and abilities’ box of Fig. 8.2. These skills and abilities can be developed through sense-making activities associated with film viewing. ICC also requires a number of other skills and abilities. For example, linguistic competence, reading, writing and speaking skills are required. For socio-linguistic competence, the student must be able to deliver their message successfully in the target language. Discourse competence requires understanding and using strategies of interaction when engaging in dialogue. Within intercultural competence, skill of interaction requires students to be able access knowledge, attitudes and skills under real-time communication constraints. These other skills and abilities can be developed by activities appropriately structured around sense-making activities.

Having a clear goal (i.e. the development of at least some of the knowledge, attitudes, skills and abilities required for ICC) for classroom activities based around the viewing of foreign films allows both teachers and students to be clear about the expected objectives and values of their learning activities, and allows teachers to construct a conceptual framework in which to place or construct

these activities. However, in order to fully achieve the goals, students should be introduced to the concept of ICC at the start of the course of study.

8.4.2 Teaching Material

Before going into specific teaching methods, the issue of ‘teaching material’ needs to be addressed. That is to say, the current section focuses on *WHAT* is to be used before addressing *HOW* to use this material.

According to the literature about using foreign films in ELT in the Chinese context, a commonly recognized teaching material is film itself. That is to say, content of the film, and sometimes the producer (e.g. producer’s intention of making the film) are the teaching materials widely recognized by language instructors. However, from an intercultural perspective, the current study provides convincing evidence that students themselves can be treated as ‘material’ in a sense that students conduct complex sense-making activities which produce rich and dynamic meanings. These should be used in teaching and learning too. This is to say, bearing the goal of developing ICC in mind, not only is the film teaching material, but also the highly diversified, culturally specific and individualised meanings, interpretations and reflections produced by the students as result of undertaking sense-making activities can also be used as teaching material. These products of the students are valuable and ready-to-use teaching materials that can be used to help develop ICC in the classroom setting.

Hence, the proposed approach of using films to help develop students’ intercultural communicative competence in ELT in the Chinese context encourages making use of the materials provided by both film and students. This does not mean other materials, such as the internet, foreign magazines, foreign newspapers and foreign books should not be used. They can be used as supplementary material around film-based activities, or similar activities can be based around them, as they are also examples of foreign media (in terms of the model).

8.4.3 Role of the Teacher

The term ‘teach’ can be interpreted in different ways by instructors from different cultural backgrounds. A common understanding of ‘teach’ among Chinese instructors seems to be *giving* information about something, *giving* lessons to students. For example, in literature produced in the Chinese context, a commonly shared view on the role of teacher among many instructors is that, in addition to helping students learn, the teacher should be *telling students what to do and what to think*. For example, You (2009) suggests the teacher selects films to help students interpret western culture from a ‘correct’ perspective and develop a ‘correct’ philosophy of life. This view is not compatible with the development of true intercultural communicative

competence, which requires students to de-centre and consider events and issues from multiple perspectives without making judgements on correctness.

The intercultural approach emphasizes that the language teacher should act as a facilitator who provides assistance and guidance to help students achieve the desired learning outcomes, instead of telling students the 'correct' way of thinking. As mentioned above, the students need to be clear about the concept of ICC and to understand that the activities they are undertaking will help them develop that competence.

8.4.4 Learning Activities

This section aims to provide examples of teaching techniques for the suggested intercultural approach of using foreign films in ELT that language instructors can consider using. The literature review identified many teaching activities based around film-viewing. These were summarised in Tables 3.1 and 3.4. The majority of these activities are designed to enhance students' comprehension and linguistic competence. They are generally teacher driven activities with pre-defined outcomes (right answers). While these activities are useful in the English language classroom, and they help develop some of the skills which are required for ICC, the focus in this discussion is on activities which arise directly out of this study and which are based around the new Foreign Media Sense-Making model described above.

Some students will perform some of the sense-making activities spontaneously on viewing a foreign film or clip, as this study showed. However, by the teacher asking appropriate prompt questions all students in a class can be prompted to undertake these sense-making activities. The outcomes of the sense-making activities will be influenced by the environment in which the student performs the activities, particularly whether they work alone, with a partner, in a small group, or with the whole class, and the extent to which the teacher prompts or leads. Apart from when students work alone, the learning takes place through a discussion, where each student voices their thoughts and ideas. The reporting of the results of the activities occurs through written reflective reports or verbal reports, and this reporting develops other skills required for ICC.

Therefore, by selecting appropriate films or clips, asking appropriate prompt questions and directing the students to consider the questions in a variety of environments (individual, with partner, in a small group, as a whole class) the teacher can facilitate the development of the students' intercultural communicative competence. Just as sense-making was shown to be a highly complex and dynamic process, the student's learning which takes place through these

activities is also not linear, but highly complex and diversified, involving all the effects described in section 8.1.6.

Having students participate in one-on-one, small group and class discussions allows them to develop a number of skills of ICC, including discourse competence and socio-linguistic competence. However, perhaps more importantly, these activities will provide opportunities for students to contact otherness (i.e. different interpretations, knowledge, life experiences) by sharing their highly diversified interpretations and views, and learning from each other. Teachers can encourage students to be open to and curious about different opinions from other students. They can also encourage students to reflect on themselves and always ask themselves the question of 'why do I think in this way?' In doing so, students can develop open and curious attitudes towards otherness and the ability to decentre.

Only certain language teachers will have the capability to implement this approach well. Clearly the higher a teacher's personal ICC, the more effectively s/he will be able to administer this approach. The need for teacher training is indicated here.

Two aspects of the new approach will be discussed here, the selection of films or clips and the selection of prompt questions.

8.4.5 Film/Clip Selection Criteria

The empirical findings clearly illustrate that both full-length films and film clips have great potential to develop students' ICC, because they not only can engage the students and stimulate rich responses from them (through the sense-making activities identified in the model), but also can influence students on many levels in various aspects (the variables, levels and skills and abilities in the model).

Due to the limitation on face-to-face contact time within the class, and the fact that teachers have a standard curriculum to follow, in the classroom setting the use of carefully chosen clips is recommended. The classroom is the place where teachers can directly influence the students' learning. The use of clips allow many more issues and situations to be explored in the time available. A single feature film may require 160 minutes or more to view. Experience gained during this study proved that clips with average length between three to four minutes can effectively grasp students' attention and stimulate rich responses and discussions. Since much of the learning around film-viewing will come from the related activities, clips of this length are recommended.

To ensure the effective use of time and resources and to achieve the desired teaching outcomes, appropriate choice of clips is vital. The rest of this section will provide recommendations on selection criteria.

- **Objective of teaching**

First of all, the teacher must decide on the desired teaching outcome(s) of the activities related to film-viewing. There will be other (not related to film viewing, standard curriculum) class-room learning activities that develop some aspects of ICC. Due to time constraints only certain aspects and levels of knowledge and attitudes will be able to be covered using the approach proposed here. The teacher must decide what will be addressed and select an appropriate set of film clips. Each film clip should have a primary purpose.

- **Subject**

This has two dimensions. The subjects addressed by the clips should be the ones that students are interested in and familiar with, because they will be interested in watching and will relate to the clips easier. They will also be more likely to learn about themselves and local people through the sense-making activities. Findings indicate subjects such as parents and children, teachers and students, school, university, young people, relationships, hierarchy in the society, racial issues are the ones that stimulated rich responses from the students and which they are very interested in.

In making the selection, teachers must make subjective decisions to some extent in terms of foreseeing the subjects that might interest the students. Both the literature review and the empirical findings of this study indicate that teachers rarely take students-related-factors into account or consult students. Indeed, some teachers let the students watch films simply because the teachers like them.

- **Films' popularity**

Clips that come from Hollywood blockbusters or popular TV series are likely to capture the students' interest. They are also more likely to watch the rest of the film or TV series from an intercultural perspective after the formal class. Teachers can check the internet for film rankings and information. In choosing the films according to the students' concept of authority, popularity and award-winning must be taken into accounts. Engaging and exciting the students is the key to success.

- **Language intensity**

This study has shown that the students' language level is a major obstacle to sense making. The English proficiency of the students should be taken into account, and clips with rapid, intense dialogues, strong accents and lack of visual cues should generally be avoided. In order for the activities proposed here to be successful it is necessary that the students can understand the clip.

- **Gender**

Are the films of more interest to girls or boys? This study has found that due to gender differences, girls and boys relate the characters differently and conduct different sense-making activities. A blend of girl clips, boy clips and neutral clips should be used. This can stimulate a range of rich responses and be helpful in organizing activities with groups of boys and groups of girls.

8.4.6 Prompt Questions: Pre-viewing and Post-viewing

This section presents suggested prompt questions which language teachers can consider using in pre-viewing and post-viewing stages. First, teachers could consider asking students some pre-viewing prompt questions. The purposes of doing this are to set the context and introducing the theme of the film without directly telling students what the film is about. A few of suggested pre-viewing prompts can be found below.

- Have you heard of ...? / Has anyone heard of ...?; What do you know about it?
- Have you been to ...? / Has anyone been to ...?; Were you happy/scared/annoyed etc ...?
- Do you like/hate ...? Why? / Does anyone like/hate ...? Why?

Different prompt questions will cause the students to undertake different sense-making activities. This section gives examples of the types of prompt questions that can be used in the post-viewing stage. The questions can be categorised according to the sense making activity they prompt. However, each individual film clip will have its own special features which will allow the teacher to generate alternative or additional questions for each category.

Comprehending the plot

- Who is/are involved?
- Where did it happen?
- What is her/his nationality/race/ethnicity?
- What has s/he done or what happened to him/her?
- Why has s/he done so?
- How do you feel about what s/he has done and why?

- What is the relationship among the characters? What do you think of it?
- Which character is your favourite and why?
- When you don't understand all the language in the clip, what else helped you understand what happened?

Perceiving as realistic

- Do you know anyone who is similar to the character? Why are the similarities?
- Can you imagine someone like this can exist in the reality? Why?
- Does the character remind you someone you know or familiar with?
- Would you be a friend with someone like the character, why?

Compare: Identifying differences/similarities

- Comparing yourself to the character, are there any differences/similarities? What are they?
- Comparing someone close to you or that you know to the characters, are there any differences/similarities? What are they?
- Have you met anyone or do you know anyone who is similar to the character? What are the similarities?
- Is it common in your culture for people to do something like the character did? Why?
- Do you think it is possible for the people where the character is from to do something like the character did? Why?
- Does what happened to the character(s) remind you of anything of yourself? Someone you know? Your own culture? Or the target country? What and Why?

Re-contextualizing

- Would you have done the same as the character and why?
- Would people around you like the character and why?
- If someone like the character did the same thing in your country, how do you think people will feel about it?
- Can you imagine someone like this that exists in the reality? Why?
- Can you imagine someone like this to exist in your country? Why?

8.4.7 Application in the Chinese Context

Due to the tradition of paper-based examinations, Chinese college students normally have the tendency of seeking for the 'right' answer. The intercultural approach of using films in ELT suggested here emphasizes the development of intercultural communicative competence which requires students to be able to decentre, be open and curious to differences, and to be able to

critically evaluate self and others. Subtly encouraging students to ‘think’ differently is a potential challenge for the teachers.

All the classroom activities can also be used in fieldwork and independent study. Due to the fact that time is limited in the classroom setting, it is helpful for the teachers to arrange assignments to encourage students to undertake the sense-making activities in their own time. In addition, there are other resources that can be used in fieldwork and independent study. For example, although direct contact with native speakers is limited, as the economy and tourism industry develop in China, it is possible to make use of native speakers as a resource in the process. For example, as fieldwork assignment, students can compare their interpretation of the film with that of a native speaker and then produce a group-presentation in the class. Having alternative input from another culture on the same film will be valuable resource. In terms of the internet, students can be encouraged to check IMDB to find out film-reviews by foreign audiences on the same film and bring it to class for discussion.

8.4.8 Application in the Wider Context

There is nothing in the Foreign Media Sense-Making (FMSM) model or the suggested intercultural approach to using films in the ELT classroom which limits it to the Chinese context. Intercultural Communicative Competence is a concept that naturally applies to people from all cultural backgrounds. The suggested approach can also be applied in ELT classrooms containing students from a large variety of cultural backgrounds, such as ESL classrooms in the U.K. In this type of environment students would be exposed to a far more diverse range of cultural views and life experience during the one-to-one and group discussions taking place around the sense-making activities. In addition, in the Chinese context students will tend to perform the sense-making activities in Chinese, as this study clearly demonstrated. However, in ELT environment where English is the only common language of the students, all communication throughout the sense-making activities would be performed in English, leading to more rapid development of Intercultural Communicative Competence in English.

Although the new model is developed from the empirical findings of current study in the Chinese context, which aimed to unveil how Chinese college students make sense of films and TV series produced in the U.K. and the U.S.A, it should be applicable to foreign media in general, including films, TV series, radios, newspaper, novels etc., wherever the media are ‘foreign’ to the viewer in the sense of being the product of a foreign culture.

8.5 Chapter Summary

This chapter presented a model of Foreign Media Sense-Making which arose from the data analysis presented in the previous three chapters. This model recognises that when viewing foreign films (or indeed any foreign media) the main focus is not on the communication of an intended message from the producers to the audience by the media. Most of the effects occurring when people view foreign media (such as refinement of knowledge and attitudes regarding the target culture and the local culture, and development of communicative skills and abilities) are unintended by the creators of the media. The model shows that by viewing and making sense of foreign media students can improve their knowledge, attitudes and skills which are relevant to Intercultural Communicative Competence. Through performing sense-making activities students learn not only about the foreign culture on several levels, but also about their own culture on several levels.

Part of Research Question 5, concerning the current use of films in ELT in China, was answered in the literature review (section 3.3.3). This chapter completed the answer to the question by looking at the experiences of the students participating in this study. A number of their teachers did show parts of films in the ELT classroom, and the intentions of the teachers varied, including relaxation, improve listening skills, improve pronunciation, and learning about the target culture. However, in almost all cases the approach of the teachers was the same: show the clip without any pre-viewing or follow up activities. Mostly the clips were shown without subtitles and the students didn't understand and felt that they gained nothing. The one exception was one application of the *Film review* follow up activity. However, the students were left unsure of what the intention of the teacher was and what they were supposed to get out of the activity.

Based on the data findings and the new model, the chapter then critically reviewed the current literature concerning the use of films and TV series in ELT. Much of current literature was found to focus on using films to help develop skills associated with linguistic and socio-linguistic competence. However, according to the findings of this study, none of the techniques suggested in the literature are being widely applied in ELT at college level in China. This study also showed that films have the potential to help develop the much wider range of knowledge, attitudes, skills and abilities required for intercultural communicative competence, something which is not discussed in the current literature.

A new intercultural approach to using films in ELT was then suggested. Based on the new model for Foreign Media Sense-Making, this approach suggests that teachers use the development of the knowledge, attitudes, skills and abilities required for Intercultural Communicative Competence as a framework for film-viewing activities. By providing the various environments

(for individual and group activities) and asking appropriate prompt questions, teachers can guide students into undertaking the various sense-making activities, and in doing so improve their intercultural communicative competence.

Chapter Nine: Conclusion

“Although this study is approaching the end, I am still fascinated by the research, just as I have been throughout this research journey, which is full of bitterness, sweetness, confusion, excitement, curiosity, self-reflection and, most importantly, sense of achievement and self-improvement. Coming to the ‘end’ of this thesis symbolizes the beginning of life-long research journey during which I will make full use of the knowledge and skills that I have gained throughout the days at School of Education, Durham University .” (My note on 06 Jan 2011)

9.1 Summary of the Study

The main purpose of this study was to find out how foreign films (including both films and TV series) are used in English language teaching (ELT) in the Chinese context, and what further potential they have from an intercultural perspective. The study originated from a research interest that the author had developed over the years, motivated by her own learning, teaching experience and observation. This research interest was to explore and unveil the value of using foreign films in ELT by looking in detail at how Chinese college students make sense of foreign films on a micro-level from an intercultural perspective.

In order to achieve the main purpose of the study, six research questions were asked.

- RQ1: From which resource do Chinese college students (CCSs) think they learn the most about the people and cultures of English speaking countries, in particular the U.K. and the U.S.A.?
- RQ2: What type(s) of media do CCSs prefer to use in order to learn about people and cultures of the U.K. and the U.S.A.?
- RQ3: How do CCSs make sense of films and TV series produced in other cultures, specifically films and TV series produced in the U.K. or U.S.A? (core question)
- RQ4: Are there any discernible effects of foreign film viewing on CCSs’ understanding of and attitudes to other peoples and cultures? If so, what are they?
- RQ5: What is the current status of using English films and TV series in ELT classroom?
- RQ6: What are the theoretical and pedagogical implications for English teachers in the Chinese context?

Before collecting empirical data, the existing literature providing the background to the current study was reviewed critically in detail (chapter three). First, the literature on mass communication models, with particular with focus on audiences and effects, indicated that the mass communication process is far from being linear. Meanings produced by audiences as result of making sense of a media program do not necessarily correspond with the meaning intended by

the producer(s). Little literature was found focusing of the effects of foreign films on Chinese audiences' knowledge of and attitudes to peoples and cultures, showing that how Chinese audiences make sense of foreign media has received little empirical research attention. Second, the literature on the development of the aims of ELT indicated that Byram's notion of intercultural communicative competence (ICC) appeared to be most relevant to the current study in the sense that, following Byram's definition, an intercultural competent individual not only can conduct successful face-to-face intercultural interpersonal communication, but s/he is also intercultural competent when interpreting cultural products (e.g. films) from other cultures, which is directly relevant to the current study.

Having reviewed the relevant literature on research methodology, a mixture of quantitative and qualitative research methodologies was adopted for the current study. The pilot study was conducted in Durham and the fieldwork was conducted in China. Questionnaires were used to answer Research Questions 1 and 2. Semi-structured interviews were used to provide answers to Research Questions 3 and 4. There were 425 valid questionnaires with 208 male and 217 female Chinese college students. Fourteen individual interviews and three group interviews were conducted. Among twenty-one interviewees, there were seven male and fourteen female Chinese college students. Research Question 5 was mainly answered by reviewing existing literature on the use of foreign films in ELT in both Chinese and non-Chinese contexts. Data collected from semi-structured interviews provided supplementary evidence on current approaches to using films in ELT used by Chinese college English language instructors. Finally, Research Question 6 was answered in the discussion chapter.

9.2 Summary of the Research Findings

This section will summarise the main research findings of this study. First, this study found Chinese college students (CCSs) believed that they learned the most about the U.K. and the U.S.A. from films (including both films and TV series) produced in the U.K. and the U.S.A. Although English teachers and textbooks were also considered main resources, CCSs did not have high expectations of them, and were not keen to make further use of them. Films produced in the U.S.A. were the most popular. When CCSs wanted to learn more about above two countries, the resource most would prefer to use was films produced in the U.K. and the U.S.A. Although CCSs expressed strong willingness to learn from direct contact with native English speakers from these two countries, access to native English speakers is limited, and is usually out of the control of both the student and the teacher.

Second, this study found CCSs are very active viewers and do not watch films passively unless they cannot understand what is going on at all. The process of CCSs making sense of films produced in

the U.K. and the U.S.A. is complex, and is far from the linear process many language instructors appear to assume. The process is full of sense-making activities which are dynamic, complex and culturally specific. As result of these sense-making activities, the meaning produced is rich, unpredictable, individualised and culturally specific. This study found that the sense-making activities fall into five main categories, *comprehending the plot*, *compare: identifying differences*, *compare: identifying similarities*, *re-contextualization* and *perceiving as realistic*. All these sense-making activities are intertwined. Apart from *comprehending the plot* and *perceiving as realistic*, the other sense-making activities happen on various levels, including *individual*, *group* and *local/foreign people in general*. Variables which affect the sense-making activities were also identified in the process of data analysis. They include variables associated with the audience, such as gender, personality, existing framework of knowledge and life experience (including whether or not the student had watched the film before), attitudes (including concept of authority), skills and abilities (including language proficiency), and philosophy of life. Variables associated with the film itself include the subject of the film and another four variables which are specifically concerned with the *perceiving as realistic* sense-making activity, *rearranged-from-true-story*, *close-to-life*, *convincing narrative*, and *acting quality*. In terms of perceiving films as realistic, this study found students could be broadly categorised by type of viewer as *believers*, *doubters*, and *sceptics*. However, various variables could cause students to change their type according to the specific film viewed. Variables associated with the environment in which the student views the film include the influence of others (including peers and teachers) and the mood of the audience.

Third, making-sense of foreign films sometimes affects CCSs' knowledge of and attitudes to both Others and Self. In terms of the natures of the effects, *reinforcement/refinement of* and *challenge of* existing understandings and attitudes, and *reinforcement of/challenge to philosophy of life* were all identified through the data analysis. The main variables influencing the extent of the effects were identified as existing framework of knowledge, life experience (including direct contact with foreigners), and peer influence (part of the *influence of others* environment variable).

Fourth, empirical findings indicated that there is a huge gap between what is in the literature and the reality of what is happening in the Chinese context. According to the participants' experience, although teachers have been using films for several purposes, including film-appreciation, relaxation, improving listening skills, pronunciation and knowledge on the target culture, inadequate teaching methods meant the educational purposes were not being achieved. Participants were not satisfied with teachers' approaches to using foreign films in the language classes.

Literature concerning both the Chinese and the non-Chinese contexts indicates that, used appropriately, foreign films are widely recognized as useful materials in ELT in terms of improving learners' linguistic competence, communicative competence and gaining more cultural knowledge. The results of this study indicate that, in addition, foreign films can be used to help develop learners' intercultural communicative competence (ICC). Here, instead of seeing films as 'mirror of the reality', as many language instructors appear to do, films should be treated as a cultural product of the other culture.

From the empirical findings relating to students making sense of foreign films and being affected by those films, including the categories of sense-making activities and the relevant variables emerging from the data, a Foreign Media Sense-Making (FMSM) model was developed to provide theoretical framework of the activities occurring when viewers watch and reflect on foreign films (chapter 8, Fig. 8.2). Although the FMSM model was developed based on the empirical study conducted in China and using the media of films and TV series, it is believed that the model can be applied in a wider context (see section 8.4.7).

Based on the processes observed in this study and represented by the FMSM model, an *intercultural approach* for using films in ELT was suggested. The purpose of intercultural approach is to develop learners' intercultural communicative competence (ICC), a notion developed by Byram (1997). In this approach the teacher selects an appropriate range of clips which will expose students to scenarios which are likely to help them develop the knowledge, attitudes, skills and abilities which form Intercultural Communicative Competence. By influencing the environment through asking suitable prompt questions and arranging opportunities for students to interact in various ways to consider these questions, the teacher stimulates the students to undertake the sense-making activities and to reinforce/refine/challenge their knowledge and attitudes, while at the same time building up relevant skills.

This thesis discussed using this intercultural approach in the Chinese context. The intercultural approach has several key features. The intercultural approach:

- Encourages making use of materials provided by both films and, in particular, the students themselves (including their different backgrounds, knowledge, attitudes and life experiences, the sense-making activities they undertake and the various meanings they produce as result). The use of students as a teaching/learning resource has received very little attention from language instructors.

- Emphasizes that the teacher should act as a facilitator instead of an ‘authority’ who tells students the ‘correct’ way of thinking and doing things, which is a common view of the role of a teacher among many Chinese language instructors.
- While recognizing the value of both full-length films and films clips in developing students’ ICC, recommends that teachers carefully choose clips with average length of between three to four minutes, because it was found that clips of this length can effectively grasp students’ attention and stimulate rich responses and sense-making activities.
- Suggests several film/clip selection criteria for teachers to take into consideration, including the objective of teaching, the subject, the film’s popularity, the language intensity and any gender specificity.
- Encourages language instructors to make full use of existing film-based activities proposed in both Chinese and non-Chinese context. In addition, it suggests that both individual- and group-activities can be designed based on the sense-making activities observed in this study.
- Suggests prompt questions which fall into five main sense-making categories (section 8.4.5) that instructors can consider to use or personalise, according to their own teaching needs and context.

9.3 Limitations of the Current Study

As with all research, this research study is not without its limitations. The main limitation is that the data was gathered from one country at one particular time. Although the theoretical and pedagogical implications which were developed from the empirical findings are suggested to be applicable in wider second language teaching context, no evidence has yet been collected to demonstrate this.

Only college students were involved in the empirical research, since the primary focus of the study was on them. However, interviews with teachers might have contributed usefully to the research on current practices of using foreign films in ELT in the Chinese context.

With regard to effect, a longer-term empirical study may have allowed clearer identification of the effects of foreign film-viewing on knowledge and attitudes (and perhaps even skills and abilities).

The FMSM model was developed from a study in which the only foreign media was films and TV series produced in the U.K. and the U.S.A., but was suggested to have wider application. No evidence has yet been collected to demonstrate that students perform similar sense-making

activities when reading or viewing other forms of foreign media, such as books, newspapers, radio programmes and magazines etc. to support the wider application of the model.

With regard to the suggested intercultural approach of using films in ELT to help students develop their intercultural communicative competence, the approach was developed based on the empirical findings, the model which emerged from these findings and the literature. The approach has not yet been tried out in a classroom setting.

9.4 Directions for Future Research

Having developed the Foreign Media Sense-Making (FMSM) model, the next step would be to test the model by using various forms of foreign media and using various groups of audiences from different countries. This would involve performing comparative studies in contexts other than the Chinese College student context used here.

Another direction of future research would be to test the suggested intercultural approach of using films to help develop learners' intercultural communicative competence (ICC) in ELT classroom. This approach can be tested in different cultural contexts as well.

Last but not least, due to the fact that FMSM contains most of the sub-competences of ICC, in particular linguistic competence, social-linguistic competence and intercultural competence (without skills of interaction), further research could focus on ways of using the FMS model as part of ICC assessment in various cultural contexts.

9.5 Concluding Remarks

In addition to being a contribution to the literature on foreign language teaching and intercultural education, this thesis is also a fruitful reflective-journal of a (part U.K.-educated) Chinese researcher's intercultural journey exploring how Chinese students make sense of films and TV series produced in the U.K. and U.S.A., and what further potential foreign films have in English language teaching from intercultural perspective, under the guidance of an intercultural team of supervisors.

One thing I have realized is that completing a PhD thesis is not only about becoming a qualified researcher. More importantly, it is about personal improvement and learning how to apply skills and knowledge, gained research, in day-to-day life. In the process of analysing data, I realize that I came to understand myself better and better. As I reach the end of this research study, I realize that I have matured, not only as a researcher, but also as a person.

One of my supervisors, Professor Mike Fleming, once said during one of our supervision sessions: “research is about contributing to knowledge”. Indeed, research is not only about understanding what is going on but also about sharing personal understandings and interpretations with the rest of the world. Although my study only focuses on audiences making sense of foreign films, I have come to the realization that we are living a life full of making sense of things around us. We live, we make sense and we research. Every researcher is different. With the same data, each researcher’s sense-making is individualised and culturally specific, shaped by their unique framework of knowledge, life experience and philosophy of life. Hence, there is no absolute right or wrong. There is always individual contribution to the shared knowledge of humankind. This thesis is my personal contribution to the shared knowledge of the wider community. I sincerely hope that my contribution will be of some use to researchers, instructors and students who are keen on using films for English language teaching and learning.

Appendix 1: English Questionnaire

Please choose the language of questionnaire.

Chinese

English

Dear Students:

I'm a Ph.D. student of Durham University in the UK. The purpose of this questionnaire survey, as part of my research, is to find out how Chinese college students acquire cultural knowledge of English speaking countries, particularly the U.S.A. and the U.K.

The questionnaire will take **NO MORE THAN 10 MINUTES** to fill in. The information you provide in this questionnaire will be used for my research only. Your personal details will be absolutely confidential and will in no circumstances be revealed to any other parties.

Your time and help is truly appreciated. If you have any queries or concerns regarding this questionnaire, please feel free to contact me at hui.yang@durham.ac.uk.

Thank you very much!

Hui Yang

Questionnaire

PART ONE: Personal details:

1. Name (optional) _____
2. May I contact you again for future reference if needed? (Please ✓)
Yes No
(If **Yes**, please give your e-mail address & name _____)
3. Sex
a) Male b) Female
4. Age
a) 16-20 b) 21-25 c) 26-30 d) 31-35 e) 36-40 f) 41 & Above
5. Nationality _____
6. Current residence:
City _____; Country _____
7. Current institution that you are enrolled in _____.
8. Type of degree that you are doing
a) Bachelor b) Master c) Ph.D. d) Post-doctorate
e) Other _____
9. Which major/subject are you specializing in?

10. Which year are you in now?
a) 1st year b) 2nd year c) 3rd year d) 4th year & above

PART TWO:

1. Which of the following countries have you been to and for what reason? (please ✓ the relevant boxes) AND, please enter how long you were there for?

If you have not been to any of the following countries, please go to question 2.

Country	For travel	For education	How long?
United Kingdom (U.K.)			
United States of America (U.S.A.)			
Australia			
Canada			
New Zealand			
South Africa			

2. On a scale of 1 to 5, how much do you believe you know about the following English speaking countries? (Please circle the relevant number)

5 = 非常多; 4 = 比较多; 3 = 一些; 2 = 比较少; 1 = 非常少

Country	5	4	3	2	1
	非常多	比较多	一些	比较少	非常少
United Kingdom (U.K.)	5	4	3	2	1
United States of America (U.S.A.)	5	4	3	2	1
Australia	5	4	3	2	1
Canada	5	4	3	2	1
New Zealand	5	4	3	2	1
South Africa	5	4	3	2	1

PART THREE:

3. Looking specifically at the U.K. and U.S.A., from your experience, how much do you believe you have learned about the people and cultures of these two countries from the following sources that are available in China? (Please circle the relevant number)

5= 非常多; 4 = 比较多; 3 = 一些; 2 = 比较少; 1 = 非常少

Sources	5	4	3	2	1
	非常多	比较多	一些	比较少	非常少
a). English textbooks	5	4	3	2	1
b). Your English teachers	5	4	3	2	1
c). Friends and/or relatives who traveled and/or lived abroad	5	4	3	2	1
d). Interacting with Native English speakers	5	4	3	2	1
e). Radio broadcasts produced in the U.K. and/or U.S.A.	5	4	3	2	1
f). Radio broadcasts produced in China	5	4	3	2	1
g). TV programs produced in the U.K. and/or U.S.A.	5	4	3	2	1
h). TV programs produced in China	5	4	3	2	1
i). Films produced in the U.K. and/or U.S.A.	5	4	3	2	1
j). Films produced in China	5	4	3	2	1
k). Books produced in the U.K. and/or U.S.A.	5	4	3	2	1
l). Books produced in China	5	4	3	2	1
m). Newspapers produced in the U.K. and/or U.S.A.	5	4	3	2	1

n). Newspapers produced in China	5	4	3	2	1
o). Magazines produced in the U.K. and/or U.S.A.	5	4	3	2	1
p). Magazines produced in China	5	4	3	2	1
q). Internet & Computers (e.g. computer games)	5	4	3	2	1
r). Other sources (please specify) _____	5	4	3	2	1

4. Of the above sources choose ONE/TWO source(s) that you prefer to use if you want to learn more about the people and cultures of the U.K. and U.S.A.

- 1) _____
 2) _____

PART FOUR:

Although many people simply watch films or TV series for entertainment purposes, in this part of the questionnaire, I'm interested in knowing about your views on learning about the culture of English speaking countries through films and TV programs.

Some films and TV series are listed below.

5. Please ✓ the ones you HAVE SEEN. For each one you have seen, please say how much you think you have learned about the people and culture of English speaking countries.

5= 非常多; 4 = 比较多; 3 = 一些; 2 = 比较少; 1 = 非常少

Films	Seen it	5	4	3	2	1
		非常多	比较多	一些	比较少	非常少
An officer and a Gentleman 军官与绅士		5	4	3	2	1
All the President's Men 水门事件		5	4	3	2	1
American Pie 1-3 美国派		5	4	3	2	1
Back to the Future 1-3 回到未来 1-3		5	4	3	2	1
Braveheart 勇敢的心		5	4	3	2	1
Basic Instinct 本能		5	4	3	2	1
Blazing Saddles 灼热的马鞍		5	4	3	2	1
Butch Cassidy and the Sundance Kid 虎豹小霸王		5	4	3	2	1
Bridget Jone's Diary 1-2 BJ 单身日记 1-2		5	4	3	2	1
Cars 汽车总动员		5	4	3	2	1
Casablanca 卡萨布兰卡		5	4	3	2	1
Crash 撞车		5	4	3	2	1
Charlie and the Chocolate Factory 查理和巧克力工厂		5	4	3	2	1
Cold Mountain 冷山		5	4	3	2	1
Dances with Wolve 与狼共舞		5	4	3	2	1

Devil Wears Prada 穿 PRADA 的恶魔		5	4	3	2	1
E.T. 外星人		5	4	3	2	1
Gone with the Wind 乱世佳人		5	4	3	2	1
Good night and Good luck 晚安, 好运		5	4	3	2	1
Harry Potter (series) 哈利 波特 (系列)		5	4	3	2	1
Forrest Gump 阿甘正传		5	4	3	2	1
Fahrenheit 9/11 华氏 911		5	4	3	2	1
Ghost 人鬼情未了		5	4	3	2	1
Grease 火爆浪子		5	4	3	2	1
Lost in Translation 迷失东京		5	4	3	2	1
Love Actually 真爱至上		5	4	3	2	1
Meet the Fockers 拜见岳父大人 1-2		5	4	3	2	1
Miss Congeniality 选美小姐 (选美俏佳人)		5	4	3	2	1
My Fair Lady 窈窕淑女		5	4	3	2	1
Mary Poppin 快乐满人间		5	4	3	2	1
Modern Times 摩登时代		5	4	3	2	1
Notting Hill 诺丁山		5	4	3	2	1
Mr. Bean's Holiday 憨豆先生的假期		5	4	3	2	1
Pirates of the Caribbean 1-3 加勒比海盗 1-3		5	4	3	2	1
Pretty Woman 漂亮女人 (风月俏佳人)		5	4	3	2	1
Queen Christina 克丽丝丁女王		5	4	3	2	1
Raging Bull 愤怒的公牛		5	4	3	2	1
Rocky 洛奇		5	4	3	2	1

Shrek 1-3 怪物史瑞克 1-3		5	4	3	2	1
Shakespeare in Love 莎翁情史		5	4	3	2	1
Shine 闪亮的风采		5	4	3	2	1
Star Wars 星球大战 1-6		5	4	3	2	1
Snow White and Seven Dwarf 白雪公主与七个小矮人		5	4	3	2	1
Stalker 潜行者		5	4	3	2	1
The Adventures of Robin Hood 罗宾汉历险记		5	4	3	2	1
The Blair Witch Project 布莱尔女巫		5	4	3	2	1
The Bodyguard 保镖		5	4	3	2	1
The English Patient 英国病人		5	4	3	2	1
The Graduate 毕业生		5	4	3	2	1
The Longest Day 碧血长天 (最长的一天)		5	4	3	2	1
The Shining 闪灵		5	4	3	2	1
The Proposition 关键协议		5	4	3	2	1
Titanic 泰坦尼克号		5	4	3	2	1
The Philadelphia Story 费城故事		5	4	3	2	1
The Silence of the Lamb 沉默的羔羊		5	4	3	2	1
The School of Rock 摇滚校园		5	4	3	2	1
The Lion King 狮子王		5	4	3	2	1
The Queen 女王		5	4	3	2	1
The Wizard of Oz 绿野仙踪		5	4	3	2	1
Toy Story 玩具总动员		5	4	3	2	1
Watership Down 海底沉舟		5	4	3	2	1

Walk the Line 一往无前		5	4	3	2	1
TV Series	Seen it	5	4	3	2	1
		非常多	比较多	一些	比较少	非常少
24 24 小时		5	4	3	2	1
Charmed 圣女魔咒		5	4	3	2	1
CSI: Crime Scene Investigation 犯罪现场调查		5	4	3	2	1
Desperate Housewives 绝望的主妇		5	4	3	2	1
ER 仁心仁术		5	4	3	2	1
Entourage 明星伙伴		5	4	3	2	1
Family Guy 恶搞之家		5	4	3	2	1
Friends 老友记		5	4	3	2	1
General Hospital 飞跃疯人院		5	4	3	2	1
Hollyoaks		5	4	3	2	1
Heros 英雄		5	4	3	2	1
Lost 迷失		5	4	3	2	1
One Tree Hill 篮球兄弟		5	4	3	2	1
Prison Break 越狱		5	4	3	2	1
South Park 南方公园		5	4	3	2	1
Sex and the City 欲望都市		5	4	3	2	1
Scrub 实习医生风云		5	4	3	2	1
The Simpsons 辛普森一家		5	4	3	2	1
The Office 办公室		5	4	3	2	1
The Wonder Years 两小无猜		5	4	3	2	1
米老鼠和唐老鸭 Mickey Mouse and Donald Duck		5	4	3	2	1
Ugly Betty 丑女也有出头天		5	4	3	2	1

6. If there are any films or TV series not listed above, from which you feel you've learned a lot about people or culture of English speaking countries, please write the names below.

1) _____

2) _____

3) _____

4) _____

THANK YOU VERY MUCH!

Appendix 2: Chinese Questionnaire

请选用问卷语言种类:

中文 英文

亲爱的同学，您好：

我是一名在读博士生，目前在英国杜伦大学就读。作为我的博士课题研究的一部分，此调查问卷目的在于了解当代中国大学生是如何获取关于英语国家文化的知识，特别是英国和美国。

此问卷只需要不超过 10 分钟来填写。您提供的信息仅用于本人博士课题研究。您的个人信息将会受到绝对的保密，不会在任何情况下透露给任何一方。

在这里，我对于您的时间与帮助表示真诚地感谢！如果您对于此问卷有任何疑问或顾虑，请随时与我联系。我的邮件是：hui.yang@dur.ac.uk

非常感谢！

杨慧

调查问卷

第一部分: 个人信息

1. 姓名 (可不填) _____
2. 如果将来需要的话, 我可以再和您联系吗? (请打)
可以 不可以
(如果可以, 请写出您的姓名和 e-mail: _____)
3. 性别
a) 男 b) 女
4. 年龄
a) 16-20 b) 21-25 c) 26-30 d) 31-35 e) 36-40 f) 41 或以上
5. 国籍 _____
6. 现居住地:
城市 _____; 国家 _____
7. 现就读大学 _____.
8. 在读学位
b) 本科 b) 硕士 c) 博士 d) P 博士后
e) 其他 _____
9. 您的专业/研究领域 _____
10. 这是您就读该学位的第几年?
c) 第一年 b) 第二年 c) 地三年 d) 第四年或以上

第二部分:

1. 您去过以下哪些国家? 去的原因是什么? (请在相关表格中打√)
并且, 请写出您在那里逗留了多久?

如果您没有去过以下任何国家, 请直接回答问题 2。

国家	旅游	学习	逗留了多久?
英国			
美国			
澳大利亚			
加拿大			
新西兰			
南非			

2. 您认为您对以下国家了解多少? (请圈选相应数字)

5 = 非常多; 4 = 比较多; 3 = 一些; 2 = 比较少; 1 = 非常少

Country	5	4	3	2	1
	非常多	比较多	一些	比较少	非常少
英国	5	4	3	2	1
美国	5	4	3	2	1
澳大利亚	5	4	3	2	1
加拿大	5	4	3	2	1
新西兰	5	4	3	2	1
南非	5	4	3	2	1

第三部分:

3. 根据您的经验, 以下列出的在国内能够接触到的资源中, 您认为从中了解到了多少关于英国和美国的人和文化? (请圈选相应数字)

5 = 非常多; 4 = 比较多; 3 = 一些; 2 = 比较少; 1 = 非常少

资源种类	5	4	3	2	1
	非常多	比较多	一些	比较少	非常少
a). 英语教科书	5	4	3	2	1
b). 你的英语老师	5	4	3	2	1
c). 曾经去国外旅游或学习过的亲戚或朋友	5	4	3	2	1
d). 和英语为母语的人交流	5	4	3	2	1
e). 英国/美国的广播节目	5	4	3	2	1
f). 中国的广播节目	5	4	3	2	1
g). 英国/美国电视节目	5	4	3	2	1
h). 中国电视节目	5	4	3	2	1
i). 英国/美国电影	5	4	3	2	1
j). 中国电影	5	4	3	2	1
k). 英国/美国出版的书籍	5	4	3	2	1
l). 中国出版的书籍	5	4	3	2	1
m). 英国/美国发行的报纸	5	4	3	2	1
n). 中国发行的报纸	5	4	3	2	1
o). 英国/美国出版的杂志	5	4	3	2	1
p). 中国出版的杂志	5	4	3	2	1
q). 网络资源和游戏(比如, 电脑游戏)	5	4	3	2	1
r). 其他来源(请注明) _____	5	4	3	2	1

4. 如果您想了解更多关于英国和美国的人与文化的话, 在以上列出的资源中, 您更喜欢使用哪个(或两个)?

- 1) _____
2) _____

第四部分:

虽然很多人看电影和电视主要是为了娱乐,但在以下问卷中,我非常有兴趣了解您对于通过英语电影/电视剧了解英语国家人民与文化的看法。

一些英语电影和电视剧已经被列出,请对您看过的电影/电视剧打√。对于您看过的电影/电视剧,请告诉我您觉得从中了解到关于英语国家的人与文化的程度。

5 = 非常多; 4 = 比较多; 3 = 一些; 2 = 比较少; 1 = 非常少

电影	看过	5	4	3	2	1
		非常多	比较多	一些	比较少	非常少
An officer and a Gentleman 军官与绅士		5	4	3	2	1
All the President's Men 水门事件		5	4	3	2	1
American Pie 1-3 美国派		5	4	3	2	1
Back to the Future 1-3 回到未来 1-3		5	4	3	2	1
Braveheart 勇敢的心		5	4	3	2	1
Basic Instinct 本能		5	4	3	2	1
Blazing Saddles 灼热的马鞍		5	4	3	2	1
Butch Cassidy and the Sundance Kid 虎豹小霸王		5	4	3	2	1
Bridget Jone's Diary 1-2 BJ 单身日记 1-2		5	4	3	2	1
Cars 汽车总动员		5	4	3	2	1
Casablanca 卡萨布兰卡		5	4	3	2	1
Crash 撞车		5	4	3	2	1
Charlie and the Chocolate Factory 查理和巧克力工厂		5	4	3	2	1
Cold Mountain 冷山		5	4	3	2	1
Dances with Wolve 与狼共舞		5	4	3	2	1
Devil Wears Prada 穿 PRADA 的恶魔		5	4	3	2	1

E.T. 外星人		5	4	3	2	1
Gone with the Wind 乱世佳人		5	4	3	2	1
Good night and Good luck 晚安, 好运		5	4	3	2	1
Harry Potter (series) 哈利 波特 (系列)		5	4	3	2	1
Forrest Gump 阿甘正传		5	4	3	2	1
Fahrenheit 9/11 华氏 911		5	4	3	2	1
Ghost 人鬼情未了		5	4	3	2	1
Grease 火爆浪子		5	4	3	2	1
Lost in Translation 迷失东京		5	4	3	2	1
Love Actually 真爱至上		5	4	3	2	1
Meet the Fockers 拜见岳父大人 1-2		5	4	3	2	1
Miss Congeniality 选美小姐 (选美俏佳人)		5	4	3	2	1
My Fair Lady 窈窕淑女		5	4	3	2	1
Mary Poppin 欢乐满人间		5	4	3	2	1
Modern Times 摩登时代		5	4	3	2	1
Notting Hill 诺丁山		5	4	3	2	1
Mr. Bean's Holiday 憨豆先生的假期		5	4	3	2	1
Pirates of the Caribbean 1-3 加勒比海盗 1-3		5	4	3	2	1
Pretty Woman 漂亮女人 (风月俏佳人)		5	4	3	2	1
Queen Christina 克丽丝丁女王		5	4	3	2	1
Raging Bull 愤怒的公牛		5	4	3	2	1
Rocky 洛奇		5	4	3	2	1
Shrek 1-3 怪物史瑞克 1-3		5	4	3	2	1

Shakespeare in Love 莎翁情史		5	4	3	2	1
Shine 闪亮的风采		5	4	3	2	1
Star Wars 星球大战 1-6		5	4	3	2	1
Snow White and Seven Dwarf 白雪公主与七个小矮人		5	4	3	2	1
Stalker 潜行者		5	4	3	2	1
The Adventures of Robin Hood 罗宾汉历险记		5	4	3	2	1
The Blair Witch Project 布莱尔女巫		5	4	3	2	1
The Bodyguard 保镖		5	4	3	2	1
The English Patient 英国病人		5	4	3	2	1
The Graduate 毕业生		5	4	3	2	1
The Longest Day 碧血长天 (最长的一天)		5	4	3	2	1
The Shining 闪灵		5	4	3	2	1
The Proposition 关键协议		5	4	3	2	1
Titanic 泰坦尼克号		5	4	3	2	1
The Philadelphia Story 费城故事		5	4	3	2	1
The Silence of the Lamb 沉默的羔羊		5	4	3	2	1
The School of Rock 摇滚校园		5	4	3	2	1
The Lion King 狮子王		5	4	3	2	1
The Queen 女王		5	4	3	2	1
The Wizard of Oz 绿野仙踪		5	4	3	2	1
Toy Story 玩具总动员		5	4	3	2	1
Watership Down 海底沉舟		5	4	3	2	1
Walk the Line 一往无前		5	4	3	2	1

电视剧	看过	5	4	3	2	1
		非常多	比较多	一些	比较少	非常少
24 24 小时		5	4	3	2	1
Charmed 圣女魔咒		5	4	3	2	1
CSI: Crime Scene Investigation 犯罪现场调查		5	4	3	2	1
Desperate Housewives 绝望的主妇		5	4	3	2	1
ER 仁心仁术		5	4	3	2	1
Entourage 明星伙伴		5	4	3	2	1
Family Guy 恶搞之家		5	4	3	2	1
Friends 老友记		5	4	3	2	1
General Hospital 飞跃疯人院		5	4	3	2	1
Hollyoaks		5	4	3	2	1
Heros 英雄		5	4	3	2	1
Lost 迷失		5	4	3	2	1
One Tree Hill 篮球兄弟		5	4	3	2	1
Prison Break 越狱		5	4	3	2	1
South Park 南方公园		5	4	3	2	1
Sex and the City 欲望都市		5	4	3	2	1
Scrub 实习医生风云		5	4	3	2	1
The Simpsons 辛普森一家		5	4	3	2	1
The Office 办公室		5	4	3	2	1
The Wonder Years 两小无猜		5	4	3	2	1
米老鼠和唐老鸭 Mickey Mouse and Donald Duck		5	4	3	2	1
Ugly Betty 丑女也有出头天		5	4	3	2	1

5. 如果您认为哪部电影或者电视剧可以让您了解到更多关于英国/美国人文与文化，而且没有被列出来的话，请注明。

1) _____

2) _____

3) _____

4) _____

十分感谢您的参与和帮助!

Appendix 3: Interview Questions

Interview (English)

(I will explain the purpose of the research and that the interviewee will have the right to withdraw from the research or the right not to answer any questions.)

A. Personal details:

1. Sex a. Male b. Female
2. The tertiary institution you are studying in _____
3. Which course(s) you are taking _____
4. Which year are you in _____
5. Hometown (if it's different from the current city you are staying) _____

B. Warm-up questions

1. In your experience as a student in the university, what are the major resources available for learning about the people and cultures of the U.K. and U.S.A?
2. If you want to learn more about the U.K. and U.S.A., which resource(s) do you prefer? And why?

C. General interview questions

1. Here is a list of English films and TV series (with pictures) that I have. Could you please have a quick look at it and then tell me which ones you have seen?
2. Among the ones you have seen, are there any of them that made a deep impression on you? And why?
3. Are there any films or TV series, either in this list or not, that helped you learn more about the U.K. or U.S.A or people in these two countries? And Why?

D. Clip-interview questions

1. I have some clips from several films and TV series. You can choose the one you want to watch. Which one would you like to watch?
2. Could you please tell me your understanding of this clip?
3. Does this clip help you learn more about U.K. or U.S.A or people in these two countries? And Why?

E. Follow-up questions (if there is enough time left)

1. Has your teacher used English films or TV series in the English class?
2. (If yes) Why and How? Do you find it's helpful?
3. (If no) Do you think it's a good idea to use English films or TV series in the English class? And Why?
4. If you were asked to recommend any film or TV series to help learning about the U.K. and U.S.A. or people in these two countries, which one(s) would you recommend?

访问 (Interview – Chinese)

(我对受访者解释研究的目的，而受访者将有权退出研究或有权不回答任何问题)

A. 个人信息:

1. 性别 a. 男 b. 女
2. 现就读大学 _____
3. 现就读专业 _____
4. 现几年级 _____
5. 老家 (如果和现居住地不同) _____

B. 热身问题

1. 根据你作为大学学生的经验，在你日常生活中，什么资源是你对于英国和美国国家和人进行了解得主要资源？
2. 如果你想对英国和美国进一步了解的话，你喜欢用哪个或哪些资源？为什么？

C. 主要访问问题

1. 我准备了一些英语电影和电视剧，它们都列在这卡片上。你可不可以快速的看一下，然后告诉我你看过哪些电影和电视剧？
2. 在看你过的电影和电视剧中，有哪些给你的印象特别深？为什么？
3. 有没有哪些这张卡片没有列到电影或者电视剧让你对英美国家有进一步的了解的呢？为什么？

D. 影视片段采访问题

1. 我准备了一些电影和电视剧的片段，你看看想看哪个？
2. 能不能给我解释一下你对这个片段的理解？
3. 你觉得这个片段有没有让你对英国或美国有近一部的了解？为什么？

E. 后续问题(如果有足够剩余时间)

1. 你的大学英语老师用过英语电影或者电视剧吗？
2. (如果用过) 用的原因和手段是什么？你觉得有帮助吗？
3. (如果没用过) 你觉得英语老师用英语电影或电视剧如何？为什么？
4. 如果有人想让你推荐几部电影或者电视剧来了解美国或者英国的话，你会推荐哪几部？

Appendix 4: Interview Film Card

American Pie
美国派

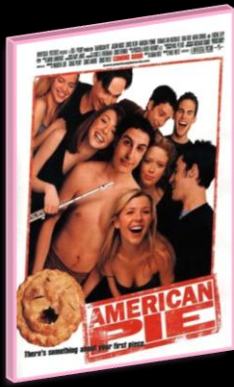

Braveheart
勇敢的心

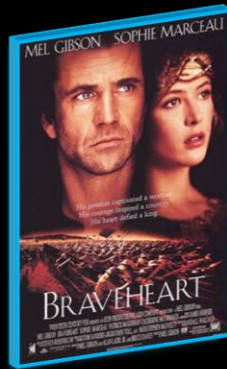

Basic Instinct
本能



Bridget Jones's Diary
BJ 单身日记

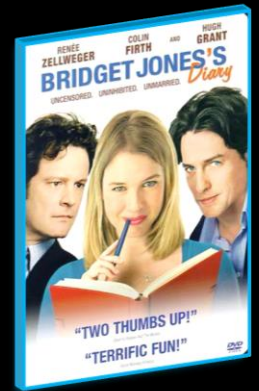

Cars
汽车总动员

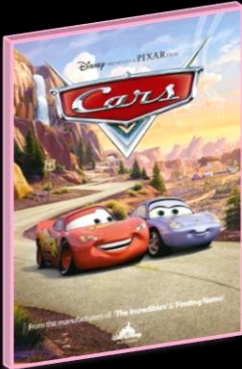

Crash
撞车



Cold Mountain
冷山



Gone with the Wind
乱世佳人



Mean Girls
贱女孩

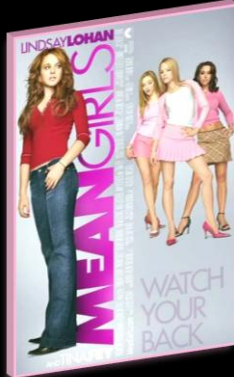

Harry Potter
哈利·波特



Forrest Gump
阿甘正传



Lost in Translation
迷失东京



Pirates of Caribbean
加勒比海盗



Shrek
怪物史瑞克



Star Wars
星球大战

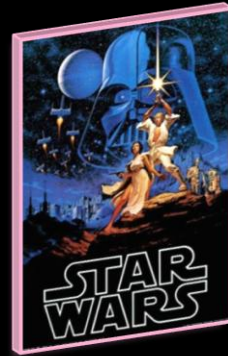

Titanic
泰坦尼克号



School of Rock
摇滚校园

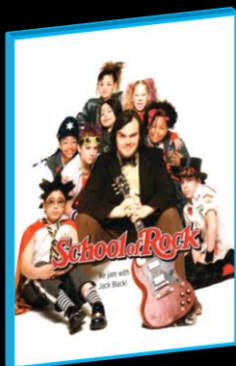

The Lion King
狮子王

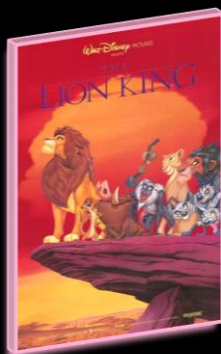

Casablanca
卡萨布兰卡



Devil Wears Prada
穿 PRADA 的恶魔



Dances with Wolves
与狼共舞



E.T.
外星人

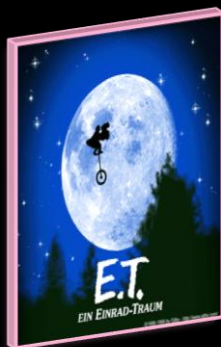

Ghost
人鬼情未了



Shakespeare in Love
莎翁情史

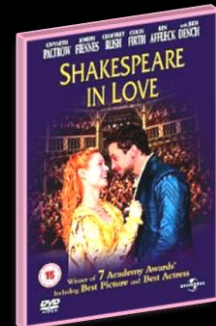

The Queen
女王



The Graduate
毕业生

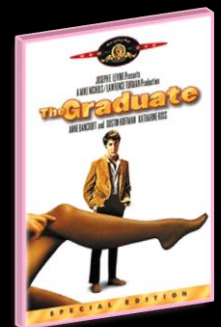

Snow White and Seven Dwarfs
白雪公主与七个小矮人



Friends
老友记

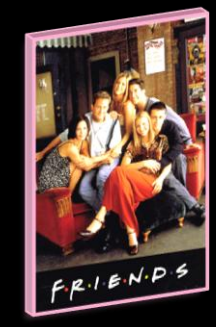

Desperate Housewives
绝望的主妇

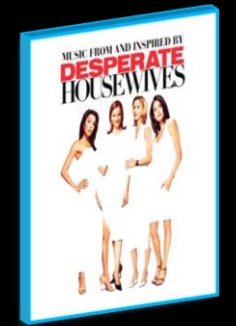

Prison Break
越狱

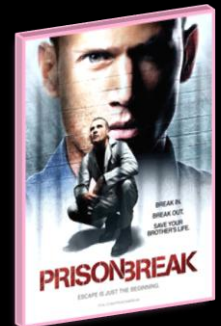

Sex and the City
欲望都市

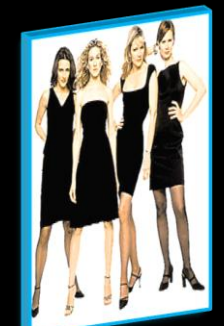

The Simpsons
辛普森一家



Appendix 5: Film Clip Descriptions

- **A father-son chat**

Film: American Pie (1999)

Setting: Jim's bedroom

Characters: Jim (final-year high school student); Jim's father

Duration: 2.5 minutes

Clip description:

One afternoon, Jim is examining a condom he just purchased. His dad comes in with three adult magazines, saying he wants to have a father-son chat. Jim's dad sits next to Jim on Jim's bed and tries to explain several female parts to Jim by using the three adult magazines he brought for Jim. Although Jim seems to be embarrassed, he lets his father keep on talking. When Jim's father asks him if he knows what a clitoris is, Jim seems to be annoyed and says: "Oh my god. Yes, I know what a clitoris is." The two talk over each other and then both apologize. Then Jim's father decides to leave the magazines to Jim. He opens Jim's bed stand's drawer and sees a condom. Jim wants to stop his father from finding out but it's too late. Jim's father remains calm and says: "well, it's better than tube socks." Jim's dad then leaves Jim's room and indicates will see him at the dinner.

- **Before the ship sinks**

Film: Titanic (1997)

Setting: the ship Titanic

Characters: Rose (young woman) Jack (young man), Thomas (designer of the ship), other passengers

Duration: 5.5 minutes

Clip description:

The ship is about to sink. People are running around trying to figure out ways to survive. Rose and Jack run into the designer of the ship, Thomas. Rose and Jack tell Thomas that it's time to leave. But Thomas decides to stay on the ship and gives his lifejacket to Rose. After Rose talks to Thomas, Jack reminds Rose is time to go. After saying goodbye, Rose leaves with Jack. While chaos is everywhere on the ship, the band is still playing a live music. After the end of a piece, the band members say goodbye to each other. However, after the members start walking away, one of the band members starts playing violin again. The rest of the members then join him to play the final piece. While the music is playing, people show different reactions towards the coming life-threatening moment.

- **Chandler's date**

TV series: Friends, Season 1, Episode 6 The One

Setting: Central Perk Coffee shop

Characters: Aurora (Italian woman in her 20s), Chandler (American man in his late 20s), Chandler's friends who are at the similar age group (Rachel, Ross, Joey, Monica)

Duration: 2.5 minutes

Clip description:

Chandler enters the coffee shop and greets his friends, Rachel, Ross, Joey, Monica. Chandler then starts telling his friends his date with an Italian woman Aurora that took place the day before.

According to Chandler, the date went very well. Although Aurora is married and has a boyfriend as well, Aurora tells Chandler that she only wants a sexual relationship with him. Monica says she is sorry things didn't work out. Chandler says he is seeing Aurora again. Chandler says he has got used to the idea that he will get the good aspects of a relationship, calling his relationship every man's dream. Phoebe and Monica dispute this. Although he denies it at the beginning, Ross then admits that this relationship is his fantasy.

- **Change the lock**

Film: *Crash* (2004)

Setting: Rick and Jean's home

Characters: Rick (husband, white), Jean (white, white), Daniel (locksmith, American-Mexican), Rick's colleagues.

Duration: 2.5 minutes

Clip description:

Rick is talking with his colleagues about his work at home. Jean comes to the ground floor from upstairs. Meanwhile, an American-Mexican locksmith, Daniel, is changing the lock on a door. Jean asks him how much longer it will take for him to finish the job. Daniel indicates that's the last lock. Jean then walks to Rick and says that she wants to talk to him for a minute. Rick walks to a corner in the house and lets Jean speak. Jean then asks Rick to have the locks changed again tomorrow because she thinks the locksmith is going to sell their keys to his gang members. Rick thinks Jean is over-reacting to what happened earlier (they got robbed by two black men). Jean is not convinced by her husband and tries to convince him. What she says contains some sensitive racial issues. Rick's colleagues remain quiet in the house. One of Rick's colleagues is black woman. She does not seem to be very comfortable with what Jean says. While Jean and Rick are arguing with each other, Daniel finishes the final lock and put the key on the table. He looks at Jean and leaves.

- **Couple dinner**

Film: *Bridget Jones's Diary*

Setting: a dining room

Characters: Bridget, Mark Darcy, Natasha (Mark's girlfriend), Tommy,

Duration: 2 minutes

Clip description:

Bridget is attending a dinner hosted by one of her friends. Among all the guests at the dinner, Bridget is the only one who is single. All other people are either married or in a relationship. Bridget ends up sitting at short end of the table, because two long-sides of the table are filled with couples. After people start eating, Tommy asks whether Bridget is still going out with Daniel, who works in the same office as Bridget. Bridget feels a bit embarrassed and says no. Tommy then tells Bridget to hurry up, while he points at his wife belly, indicating she is pregnant. Tommy then says that he doesn't understand why so many office girls with fine bodies cannot secure a man. Bridget asks Tommy whether it is one in three or one in four married couple who end up divorced. People keep talking and eating, and don't seem to notice Bridget's question. However, Mark answers the question by saying: "one in three." Bridget seems a bit surprised. Another female raises another question, asking why there are so many 30-something single women nowadays. Everyone looks at Bridget expecting an answer from her. Bridget indicates that she doesn't know and says: "perhaps it doesn't help that underneath the cloth our bodies are covered by scales." People then continue eating.

- **College day**

Film: Forrest Gump (1994)

Setting: in front of Foster Auditorium at the University of Alabama

Characters: Forrest (a simple man in his early 20s from Alabama, U.S.A.), , George Wallace (governor of Alabama), reporter, crowd (full of students and local people)

Duration: 1.5 minutes

Clip description:

Forrest is on the way to the University of Alabama and sees a crowd gathered in front of the Foster Auditorium. Forrest asks the guy next to him that is happening. The guy tells him that black people are going to the same university with them (white students). The Forrest sees the Alabama Governor George Wallace standing in front of Foster Auditorium in an attempt to stop desegregation of Alabama University by the enrolment of two black students, Vivian Malone and James Hood. While George is delivering his speech concerning the trend of military dictatorship of the country, Forrest is standing right next to him and a bit behind one of the soldiers next to George. Meanwhile, a reporter stands behind the crowd is describing the situation which is broadcasted live on TV. After Forrest moves away from the entrance of Foster Auditorium to see what is going on, two black students who have signed up for the summer courses walk into the building. The female student, Vivian, drops her notebook on the ground, but she doesn't seem to notice it and keeps on walking. Forrest picks up the notebook and returns it to Vivian.

- **Dining saloon**

Film: Titanic (1997)

Setting: first-class dining saloon, ship Titanic

Characters: Jack, Rose, Ruth (Rose's mom), Cal (Rose's fiancé), other guests on the ship including, Molly (middle-aged woman), Thomas (designer of the ship, middle-aged), Colonel Gracie (middle-aged man) etc.

Duration: Four and a half minutes

Clip description:

To thank Jack for saving Rose's life, Jack was invited to attend dinner at first-class dining saloon. Jack, in nice black suit borrowed from Molly, meets with Rose and walks with her towards the dinner table. On the way to the dinner table, Rose introduces Jack to different people.

The seating arrangements: Jack is seated opposite Rose, who is flanked by Cal and Thomas. Also at the table are Molly, Colonel Gracie, and four other guests.

Cal explains to the guests that Jack is from third-class and that he helped Rose. As waiters serve caviar and champagne, Rose says that Jack is a good artist and has shown her his work. Cal says that his opinion of fine art is different from Rose's, but that he does not wish to insult Jack. Jack waves at Cal. Rose coughs and gestures at Jack as the food is served. Jack takes his napkin and looks at the silver on the table in front of him. He asks Molly if this is all for him. Molly tells Jack to start at the outside and work his way in. While other people are talking, a waiter leans in front of Jack and asks him how he takes his caviar. Jack declines the caviar, saying he has never liked it. Rose smiles and looks down. Ruth asks Jack where he lives and how he can afford to travel. Rubbing under his nose, Jack says that he works from place to place and, with a repeated downward pointing motion of his hand, that he won his ticket on Titanic. Colonel Gracie says that life is a game of luck. Cal says that men make their own luck and asks Jack what he thinks about this. Jack replies with an upward jerk of his chin and a back-channel hum. Ruth asks if Jack likes his rootless existence. Jack says that he has everything he needs with him. He bites a bread roll and

says he loves not knowing what will happen each day. Ruth is watching him. He takes more champagne and says that life is a gift. Cal puts a cigarette in his mouth and Jack throws a box of matches to him. Jack says that they must “make each day count.” Molly says he has spoken well and Colonel Gracie says, “Hear! Hear!” Rose raises her glass “to making it count” and the guests drink to this.

- **Director**

Film: Crash (2004)

Setting: studio

Characters: Cameron (director, black), Fred (member of production crew, white), Jamal (actor, black)

Duration: 1.5 minutes

Clip description:

Cameron, the director, is very happy with the shooting of the commercial and the actor Jamal’s performance. As he walks away to get some coffee, Fred follows tells Cameron that they need to shoot the scene again. Cameron says that the shoot looked “pretty terrific”. Fred asks Cameron if Jamal is seeing a speech coach and if he has noticed that Jamal is “talking a lot less black lately”. Cameron laughs. Fred asks Cameron if there is a problem between Cameron and himself. Cameron says that they do not have a problem. Fred then claims that Cameron is “the expert” on this issue, but explains that one of Jamal’s lines rings false. After looking at Fred for a while, Cameron shouts to the crew that they will shoot the scene once more.

- **Lesbian wedding**

Film: Friends Season 2, Episode 11: The One with the Lesbian Wedding

Setting: event hall

Characters: all six friends (Rachel, Ross, Phoebe, Joy, Monica, Chandler), Carol (Ross’s ex-wife), Susan (Carol’s partner), guests to the wedding

Duration: 2 minutes

Clip description:

All six friends attend Carol’s wedding to Susan. Carol’s parents’ won’t give her away. Ross decides to give Carol away instead at the wedding. Joy and Chandler complain about not enjoying women’s attention at the wedding. Everyone witnesses the wedding ceremony.

- **London bench day**

Film: Love Actually (2003)

Setting: On a bench next to London Thames river, U.K.

Characters: Daniel (step-father), Sam (son, 11-year-old boy)

Duration: 1.5 minutes

Clip description:

Daniel and Sam are sitting on a bench in silence, looking across the Thames. Daniel has been worrying about Sam because Sam’s mom recently passed away. Daniel feels that he needs to talk to Sam to find out reasons why he’s been so upset recently. Daniel turns to Sam and asks what the problem is and tries to find out whether Sam’s been bullied at school. Sam reveals that he is in love. Daniel laughs and says that he is relieved because he thought it was something more serious. However Sam tells Daniel that nothing is worse than “total agony” of being in love. Daniel agrees. Both of them then look across the river together.

- **Phoebe calls London**

TV Series: Friends Season 4, Episode 24: The One with Ross's Wedding: Part 2

Setting: Monica's living room

Characters: Phoebe, British House keeper (in London Emily's house)

Duration: 1.5 minutes

Clip description:

In Monica's living room in New York, Phoebe tries to get in touch with the other four friends in London to warn them that Rachel is coming to London to tell Ross that she is still in love with him. Phoebe is worried that this will destroy Ross's wedding with Emily. She decides to give Emily's London house a call. A middle-aged British woman answers the ringing telephone, announcing it is the Waltham Phoebe asks this woman if it is Emily's parents' house. The woman in the house identifies herself as the housekeeper and tells Phoebe that her telephone manner is inappropriate. Phoebe listens as the housekeeper tells her that, on the telephone, first, one identifies oneself, and, secondly, one asks for "the person with whom one wishes to speak." Then the housekeeper puts down the receiver. Phoebe shouts, "No!" but it is too late; she redials. The housekeeper again answers saying it is the Waltham residence. Phoebe greets the housekeeper and introduces herself. Saying "please" many times, Phoebe asks to speak with Emily, "if it's not too much trouble." The housekeeper informs Phoebe that Emily is at a rehearsal dinner and that it is impolite to mock people. She says goodbye and moves to put the phone down. Phoebe shouts, "No!" again and promises to be nice. She then asks for the telephone number of the location of the rehearsal dinner. The housekeeper declines to give her this information. Phoebe tells the housekeeper that the wedding may be ruined; she threatens the housekeeper and demands the number. The housekeeper is annoyed by Phoebe and hangs up the phone.

- **Prepare for launch**

Film: Bridget Jones's Diary (2001)

Setting: a bar in London

Characters: Bridget (30-something British single working woman, Sharon, Jude, Tom

Duration: 2 minutes

Clip description:

Bridget needs to prepare for an important social occasion at her work, at which Bridget plans to entice Daniel (her boss), the man she fancies and hopes to date. Bridget meets her close friends Jude, Sharon and Tom, at a London bar to ask for help. Each of the three friends gives her tips. The clip also includes Bridget's preparation in her bedroom, such as choosing which underwear to wear, practicing her introductory speech, etc.

- **Prom**

Film: American Pie (1999)

Setting: event Hall

Characters: Jim, Kevin, Chris, Finch, Michelle,

Duration: 1 minute

Clip description:

Upon graduation from high school, Jim, Kevin, Chris and Finch all attend the Prom. Jim attends with his date, Michelle, who keeps telling him about her stories happened in Band Camp. Kevin and Chris attend the prom with their girlfriends, whilst, Finch attends the prom along.

- **Rachel doing laundry**

TV series: Friends Season 1, Episode 5: The One with the East German Laundry Detergent

Setting: laundry room

Characters: Ross, Rachel, middle-aged woman

Duration: 3 minutes

Clip description:

Eager to spend time with Rachel, Ross pretends his building's washroom is not working so he can join her at the laundry room in Rachel's building. When they are both in the laundry room, Rachel puts her basket on the washing machine so that people know it is reserved. However, a middle-aged woman moves her basket away and puts her clothes in instead. Rachel tries to get the washing machine back but gets told off by the woman. Ross sees everything and tells the woman that she should give Rachel back the machine because she knows the rules. Then the middle-aged woman gives in. Rachel is very happy with Ross's help.

- **Return home**

Film: Brave Heart (1995)

Setting: Wallace's hometown in Scotland

Characters: Wallace (Scottish young man), Murron (young Scottish woman), Hamish (Wallace's childhood friend in his hometown), other villagers.

Duration: 3.5 minutes

Clip description:

After growing up with his uncle abroad, Wallace returns to his hometown in Scotland. On the day of his return, there is a wedding party in the village. Wallace walks around and sees a beautiful young woman Murron who looks at him too. Suddenly, Hamish drops a big rock in front of Wallace to test of his manhood. Hamish says that English do not allow Scottish people use weapons, and hence they train themselves by throwing rocks. Wallace and Hamish start a competition to see who will knock the other down by a rock. Hamish throws a big rock towards Wallace but misses. Then it's Wallace's turn. Wallace picks up a small piece of stone from the ground instead and throws it at Hamish. The stone hits Hamish's forehead. After a short while, Hamish feels dizzy and sits on the ground. People start cheering happily. Hamish welcomes Wallace back home. The party goes on.

- **Shop for gun**

Film: Crash (2004)

Setting: A gun store

Characters: Dirk (gun store owner), Farhad (American-Iranian, 50s), Dorri (daughter to Farhad, 25, Andy (security guard)

Duration: 2 minutes

Clip description:

In a gun shop, Dirk, gun shop owner, after showing a revolver to his customers, says: "You get a free box of ammunition, what kind you want?" Farhad looks at the handgun and turns to his daughter Dorri then asks her in Farsi: "What did he say, ammunition?" Dorri then explains to him in Farsi what Dirk said. The Dirk asks what kind of bullets they would like. Farhad and his daughter start talking Farsi (subtitled) to discuss. At this point, Dirk says "Yo, Osama." Farhad and his daughter exchange comments in Farsi (unsubtitled). Farhad then asks Dirk if he is insulting him. The shopkeeper ridicules Farhad's English. Farhad raises his voice and declares himself to be an

American who knows his rights. Dirk pulls the gun back to his side of the counter and calls to a security guard, Andy, who moves towards them. Dorri tells her father to wait in the car. Dirk and Farhad shout at each other as Farhad and the security guard leave. Dorri tells Dirk to give her the gun or the money and that she'd prefer the money. Dirk slides the revolver back across the counter and repeats his question. Dorri asks for whatever ammunition fits. Dirk lists many kinds of ammunition, saying that all these fit the revolver. Dorri asks for "the ones in the red box". Dirk takes the red box and places it on the counter with the gun. Dorri snatches them up and leaves.

- **Step off**

Film: School of Rock (2003)

Setting: A primary school classroom in U.S.A.

Characters: Dewey (a 4th grade substitute teacher), Zack (one of Dewey's students, boy), and other students.

Duration: 3.5 minutes

Clip description:

While Dewey is walking to school in the morning, he sees Zack's father tell Zack off, telling Zack to do more work and no more rock music. After enters the school, Zack sits at his desk with his head on his hands. Dewey notices this. Then he praises the students, telling them they would have perfect grades, but also tells them, "Rock ain't about doing things perfect." Dewey encourages the pupils to tell him off, to break the rules and to enter into the spirit of rock. He then declares that it is time to write a rock song and asks the class what makes them angry, singing each of their complaints back at them in the form of rock lyrics. Zack is asked to provide a line of the song; his phrase (step-off) becomes the chorus and the whole class sing it together at the teacher's prompting. The children laugh and then clap as the teacher takes a bow.

- **Stifler's party**

Film: American Pie (1999)

Setting: Stifler's mom's house

Characters: final-year high school students (Stifler, Jim, Kevin, Sherman, Nadia, Chris, and other students at the party), a college female student

Duration: 4.5 minutes

Clip description:

Stifler is having a house party with a lot of final-year high school students attending. During the party, Stifler, the host, greets the guests, especially the pretty girls. While everyone is talking to everyone, Jim believes Nadia looks at him. Jim's friend, Kevin encourages Jim to go for it. Jim then tries to start a conversation with Nadia, unsuccessfully. Sherman tries to show off to Kevin and Jim that he is probably getting laid with a girl tonight. Jim and Kevin don't believe him. Meanwhile, in a field outdoor, Chris is sitting in a car with a college girl. Chris attempts to have sexual contact with the girl but failed. The girl tells Chris that he should be sensitive to girls.

- **The noble right**

Film: Brave Heart (1995)

Setting: a village in Scotland

Characters: Wallace, Hamish, groom, bride, villagers, English noble, English soliders

Duration: 2.5 minutes

Clip description:

On the day Wallace returns to his hometown in Scotland, the villagers are celebrating a wedding for a Scottish couple. While people are dancing and celebrating, a group of English soldiers are approaching. The English noble declares that it's his noble right to take the bride to his bed on the wedding night. The groom is very angry and wants to fight back but stopped by the soldiers with weapons. The bride stops the groom from struggling and indicates that she will go with the noble.

- **Two black men**

Film: Crash (2004)

Setting: a street in New York city, U.S.A.

Characters: Anthony (young man, black, early twenties), Peter (young man, black, early twenties), Rich (husband, white) and Jean (wife, white)

Duration: 2 minutes

Clip description:

Anthony flies out the door of a diner, Peter just one step behind him. Anthony is complaining about the service at the diner and suggests their poor service was racially motivated. Peter points out that the waitress (like Peter and Anthony) was black. Anthony asks Peter whether or not black women think in stereotypes and says that the waitress thought they wouldn't tip because they were black. Peter asks how much Anthony tipped. Anthony asks Peter whether he expects him to pay for the sort of service they have received. Peter laughs.

Meanwhile, a white couple, Rick and Jean walk together past a cinema while talking to each other. Anthony and Peter stop walking and watch the couple. Anthony says that Jean is afraid of Anthony and Peter because they are black. Peter says she is cold. Anthony says that they do not look threatening and that if anybody should be scared it is them. Anthony asks Peter why they are not scared. Peter says it is because they have guns. Anthony and Peter then each remove a handgun from their trousers and run toward a black car. Peter opens the car door, raising his weapon, and shouts at Jean, telling her to get out of the car. Anthony points his gun at Rick's face and demands the car keys. In the end, Anthony and Peter drive Rick's and Jean's car away.

- **Two policemen**

Film: Crash (2004)

Setting: a road in New York, U.S.A.

Characters: police officer John (white), police officer Tom (white), Cameron (director, black), Cameron's wife (half black and half white).

Duration: 6.5 minutes

Clip description:

One evening in New York, two police officers on-duty are informed with the description of a stolen car. John sees a car running on the road and starts following the car. His partner Tom who sits in the car with John points out that the car they are following is not the stolen car reported. But John insists that the couple in the car were doing something. He stopped the car and asked the couple to get off from their car. John starts checking whether Cameron has been drinking. Cameron's wife gets annoyed and says that Cameron never drinks and is Buddhist. John then asks both of them to put their hands behind their heads and stand against the car. Cameron's wife is angry and indicates that the reason why John is doing this to them is because of racial issues. Cameron asks his wife to stop talking. After searching Cameron's body, John starts searching Cameron's wife's body when she only wears a cocktail dress. She feels humiliated. Cameron asks

John to let them leave with a warning. John agrees and asks for Tom's opinion. Tom agrees by saying only: "yah." Cameron and his wife get on the car and drive away.

- **Virgin deal**

Film: American Pie (1999)

Setting: living room

Characters: Jim, Chris, Kevin, Finch, Sherman, a high school girl

Duration: 3 minutes

Clip description:

Three final-year high school boys, Jim, Kevin and Chris are resting in the living room after a house party the previous night. Finch, another high school boy, comes in and greets everyone. While they are talking about why Finch missed the party last night, Sherman came out from one of the rooms with a high school girl, they tell each other how special last night was and hugged goodbye. Jim and three of his friends were shocked by this scene. After the girl leaves, Sherman walks towards four guys and tells them that he is a real man now. Jim asks Sherman how he managed to make that happen. Sherman says it's just his time. He then wishes luck to other four guys and leaves. Jim and his friends cannot believe what happened to Sherman. They realize that they probably will end up going to the university as virgins. They decide to lose their virginity before high school ends.

- **Women and children first**

Film: Titanic (1997)

Setting: ship Titanic

Characters: Captain, ship crew

Duration: 2.5 minutes

Clip description:

Not long after the Titanic hits the iceberg, the captain is informed that the ship is going to sink in one hour's time, while the rescue ship will not arrive until four hours later. Hence, it becomes vital to get passengers on the lifeboats. However, the numbers of lifeboats on the ship are only enough for around half of the passengers. One of the crew suggests to the captain to let the women and children board on the lifeboats first. The captain agrees. After the decision has been announced, the band starts playing a live music on the ship. During the process, a little girl asks her mom when they can get on the boat, and her mom says they have to wait until the first-class passengers get on the lifeboats.

Appendix 6: Sample Individual Interview Transcript

INTERVIEWER: 到了北京习惯吗?

GW: 还是时候气候不是很习惯, 但是到了后来就好了, 还挺习惯的。

INTERVIEWER: 那学习呢?

GW: 上大学第一年一开时很不适应[……] 当时就特别不知道应该把中心放在哪里[……]感觉挺迷茫呢[……]但是现在基本上适应了。

[…]

INTERVIEWER: 那你在上大学期间你对英语国家, 特别是英国和美国, 你是主要通过哪些渠道进行了解的呢?

GW: 杂志, 还有老师, 因为英语课也是很重要的一门课, 那个老师在课堂上也会弄一些英美文化方面的。另外就是电影, 我看杂志比较多, 还有就是电视剧吧。那时候上英语课老师经常放老友记给我们看。

INTERVIEWER: 你刚才说的那个杂志, 什么样的杂志?

GW: 21 世纪英语报啊。

INTERVIEWER: 哦!

GW: 都是一些, 家开始是想借着杂志学英语, 然后那些杂志里面就会有一些英美文化方面的, 慢慢渗透到那个, 而且我也想过要出国, 所以归欧美的大学比较关注那种。

INTERVIEWER: 来看看你杂志比较多啊, 那你说在这个杂志中有没有印象比较深的文章, 或者是你还记得的, 能够让你对英国或者美国一点了解的?

GW: 说起来还挺惭愧的。我一般都肤浅的看了看, 对里面那些主要是八卦的啊, 明星的新闻比较感兴趣, 我觉得比较让我比较, 对美国 and 英国大学生啊, 对待那个…就是…

INTERVIEWER: 慢慢想, 没关系。

GW: 就是我对历史古老的国家比较感兴趣, 比如说美国和英国, 我对英国就比较感兴趣, 对那些有些, 杂志有时候会介绍一些英国的那些古老的背景, 比如说传说啊什么的, 还有那些宫殿以前的背景只类的, 我对一些关于介绍英国巨石镇的那个文章觉得印象特别深刻。

INTERVIEWER: 那你一开始看报纸的目的是…?

GW: 学英语。

INTERVIEWER: 哦! 那那种古老的东西是属于个人兴趣?

GW: 对, 个人兴趣。我对历史比较感兴趣。

INTERVIEWER: 在你的问卷当中, 你给老师打的分数也很高, 你们老师是怎么帮助你啊? 就是说, 在文化这方面, 老师是怎么做的?

GW: 因为我们有一个外教, 他是一个英国人, 他上次给我们放他在伦敦拍的一些照片, 伦敦个大景点, 他给我们放 PPT 给我们看, 老师在上课中, 我觉得上大学和高中不同的就是, 上高中, 老师教英语就是语法知识啊, 很少涉及那些英美文化背景, 然后上大学老师对语法这块, 单词这块讲的比较少一点, 介绍那些大学, 象我们上个学期那个老师去澳大利亚进修了嘛, 他走之前就给我们介绍了澳大利亚的教育体系, 还有大学什么的, 他们就平常上课就会讲一些

INTERVIEWER: 那你们的老师有没有用过电影?

GW: 经常放, 我们上个学期, 大一课比较轻松, 也没有考 4, 6 级的压力, 然后老师, 英语课课间都会放 Friends. 放一集, 然后有时候比如说, 一个月会给我们放一次电影给我们看, 放一些迪士尼的动画片。放那个 ‘海上钢琴师’, 还有那个女王, 就是英国刚拍的那一部电影嘛, 还有…挺多的吧。

INTERVIEWER: 你们老师是如何用电影的呢? 组织其他的活动吗? 还是只是放电影?

GW: 没什么其他活动。挺单调的。

INTERVIEWER: 那你们老师怎么选择电影的? 那你们要看什么就看什么, 还是老师…?

GW: 他没有问过我们。他一般都选择那些句子比较浅显的, 不是特别深奥的, 动画片放的特别多。Dysney 的动画片放的特别多。[……] 还有比较经典的海上钢琴师’, 阿甘正传啊, Brave Heart, D 与狼刚舞, 就是比较经典的。不是特别经典就是特别幼稚的我觉得。就没有一个特别贴近我们生活的。哦,

对了。上次放了一个足球宝贝，就是说一个女生，打扮的像个男生，然后进学校的足球队，挺搞笑的。

INTERVIEWER:你刚才说到电影和电视剧，什么样的电影，电视剧？你能解释一下吗？

GW: 贴近生活的。还有那个历史文化氛围的。比如关于英国以前贵族的生活什么的那些，我也挺乐意了解的。还有一些就是…美国的电影看的比较，也不是特别多，但是经常有好的，大家都推荐的话就愿意看。

INTERVIEWER: 哦，是吗？

GW: 恩。什么公主日记啊，和 Dynsney 大家都很喜欢看的。

INTERVIEWER:你刚才说到主要渠道是通过电影和电视剧，你能解释一个一下电影和电视剧怎么，在哪一方面，帮助你了解英美国家了？就是，人啊，文化啊这类东西？

GW: 就是通过他们的语言吧。我觉得，看电影和电视剧，象里面人物说的英语啊，跟我们上英语课本上学到的不是完全一样的。他们就比较贴近口语化。通过他们表达语言的方式，可以了解他们的思维方式啊什么的。光是从课本上那些写的很正规的那种文章，根本了解不到西方的思维方。

INTERVIEWER: 有没有哪部电影给你印象比较深的呢，从文化这个角度，或者是你就觉得印象特别深的电影？

GW: Forest Gump 吧. 还有 ‘心灵捕手 Good Will Hunting, 还有 The Shawshank Redemption.

INTERVIEWER: 印象比较深？

GW:对。因为这个老师经常放，然后印象特别深刻。

INTERVIEWER:为什么会这么深刻呢？主要是故事情节还是怎么样？

GW: 主要是故事情节，还有人物的性格。

INTERVIEWER: 哦。

GW: 如果说比较有趣一点的，我最近就特别喜欢看 Princess Diary，第三部快出来了。

INTERVIEWER: 公主日记是不是那个本来是一个贫民的小姑娘，然后回去当公主的那个？

GW: 对，就是那个。

INTERVIEWER: 你为什么这么喜欢这个电影？

GW: 大概女孩子都觉得从灰姑娘变公主的感觉特别好吧。看着挺有意思，挺轻松的。

INTERVIEWER: 那你觉得，虽然这个电影是关于公主的，那你觉得有没有让你对那边的人啊，或者是习惯啊，反正通过电影让你有没有了解吧，有吧？

GW: 我觉得 Princess Dairy 对我挺大的感触就是，因为那个公主她本来是生活在美国嘛，可是她的奶奶是一个欧洲那边的一个皇族。他们在。。。其实觉得英美两个国家还是有很大差异的，英国比较古老传统，结果她们两个在一起发生很多摩擦碰撞啊，就是感觉古老思想和现代美国人的文化进行一种冲撞那种感觉。就是她和奶奶之间经常会发生矛盾啊，她会比较随意吗，不象贵族那样举止幽雅啊什么的，有点象外国版的“还珠格格”了。

INTERVIEWER: 这个电影的主要线索之一也是奶奶和孙女之间的关系，那 Princess Diary 有没有让你对西方人，比如说长辈与晚辈之间的这种关系有一定认识呢？

GW: 我觉得和中国不一样的地方挺多的。我觉得它那个上面的奶奶对孙女还是比较理解的。虽然她一开始就一直是一个贵族，一个王后，一个国家的统治者，可是她接触到一些新鲜事物文化的时候改变思想也很快的，可以接受一些新的想法。我觉得跟中国没什么大的差别，因为我奶奶也很开放。她接受新事物特别快。恩…不过相比较与中国来说，中国现在每个家长都象那样几乎不太可能的，中国家长那种，家长权威，孩子观念上特别…

INTERVIEWER:那你觉得希望那边长辈和晚辈之间的关系是如何的呢？虽然你没有出过国，但是设想一下？

GW: 我觉得英国，比中国应该自由一些。最起码他们愿意放下自己所谓的架子啊，跟小孩子心平气和的去沟通。

INTERVIEWER: 在你的问卷中，我有问到主要通过哪种途径，你好象说到中国广播…？

GW: VOA.

INTERVIEWER: 哦！VOA.

GW: 然后老师还让我们听 BBC 只类的新闻。不过，老师让我们听的主要目的还是锻炼我们的听力。我觉得这个跟平时课堂上的听力教材还是有很大区别不一样。我们也就经常听一些广播什么的。

INTERVIEWER: 哦！

GW: 我觉得那个挺锻炼人的听力的。挺好的。如果想了解英美国家文化生活的活的话，我觉得听这个应该比听力教材管用的多

INTERVIEWER: 你在最后推荐了一部成长的烦恼？

GW: 对。

INTERVIEWER: 你看了很多吗？

GW: 我看的不是很多，因为就是高三毕业暑假看的。就是感觉听嘻嘻哈哈的。我对美国的电视剧的印象就是那种感觉，挺嘻嘻哈哈的。不象中国的电视剧。每个电视剧非要弄一个主题。非得什么思想政治教育方面的，非得往哪个精神主义那方面靠那种。我觉得他们就是写一些很平淡的生活，感觉没什么非得有一个中心思想吧，非得突出特别跌荡起伏的情节啊，但是每一集感觉特别贴近显示生活那种。挺平常的那种。生活中平凡，但是很有趣的那种。他那个电视剧就是讲的一家人，然后几个孩子在一起，小孩子，恋爱，烦恼，经常成长中的烦恼啊那些。[...] 比如说象那个小孩子，处于青春期成长发育当中吧，他想那个买那个 Bra，然后象那种事情她爸爸妈妈就会跟她细心交流啊，帮她去商店给她挑选啊，我觉得在这个方面吧，特别是在那个方面中国家长还是比较保守的。她那个就是家长愿意心平气和帮她去了解啊什么的。就她那个第一次月经，她妈妈都会很耐心跟她将啊，我觉得这在中国简直不可能。我觉得触动挺大的。象一般美国人都很开放，那上面不仅母亲对那方面，女孩子进入青春期这方面教育挺关注的。而且她爸爸也挺关注她这方面的，跟中国的文化差异很大的。

INTERVIEWER: 就是给你印象深？

GW: 对。就是那一集感觉印象特别深。而且在家还特别自由。那个女孩有一个小弟弟，跟她经常对着干嘛，我觉得在中国家庭马，不要说就是两代人之间，就是长辈和晚辈，我们家就是平辈之间比如说姐姐比弟弟妹妹大很多，弟弟妹妹对姐姐也要有一定的尊重。可是她的弟弟就拿她姐姐开玩笑啊什么的，感觉特别轻松吧。跟中国挺不一样的。

(Interviewer: explains about the film cards)

[...]

GW: 我平时还学日语，所以平时对日本文化比较感兴趣。

Interviewer:: 对，所以挺深刻的。

GW: 对 Lost in translation 印象特别深刻。有时候脑袋会混乱，就是关于那个，感觉东方文化和西方文化特别不一样。特别深厚的感觉。

Interviewer:: 能不能解释一下？

GW: 就是感觉东方文化和西方文化差别挺大的。我觉得日本这个民族和中国还。。。我觉得日本挺奇怪的，他们明明是亚洲国家，但是他确能几十年名列于世界强国，我觉得日本民族性特别奇怪。因为你看 Lost in translation。就是在日本，日本人就是感觉他很希望把自己靠向欧美那个方面，可是他们骨子里还摆脱不了自己是亚洲人的那个。。。就是东西方都结合吧，他们。。。就是感觉在日本那个民族的对他的历史了解过程中，对他的感觉更多的东西放文化的碰状吧。因为我了解日本明知威信的历史，它当时也是对美国被迫打开过门，可是他不象中国那样，一味的抵制，他被迫打开了自己的大门之后还反而笑脸相应那些，明明是别人用尖船礼炮打开过门，他们却很礼貌的，很乐意的换了另外一部嘴脸，把美国将军接到自己的国家，给他们家道欢呼的那种感觉，他们完全可以以另外一种心态。。。如果放在中国，大家肯定是民族气概特别高涨。我觉得日本民族最大的特点就是，永远看向强的一方。永远只跟着强的一方走。

Interviewer:: 你是读书看书学到的？

GW: 对。还有今年住家带了一个日本朋友回家。开始挺期待的，我学日语很长时间了，我带她回家，可是我发现在我家带了 2 个星期之中我们之间也产生了不少摩擦碰状什么的，就是感觉还是有很多文化差异。虽然日本和中国也是一脉相承的国家吧，可是我觉得还是有很多文化差异。比如说我就受不了她那种太过于礼让谦让那种，比如说她在我家吃个饭，每夹一个菜她都要站起来，鞠躬说谢谢什么的，然后我觉得特别不习惯。开始大家都觉得日本人很有礼节嘛，可是在我家带了半个多月了吧，我觉得现在在中国嘛，没有必要强调这么多理解，可以她就是根本从性格上改变不了。就是很...我知道日本人有很多礼节，我们明明是中国交往的方式很真诚的对待她，可是我觉得他们就是，因为太多的礼节了，就是把人感觉举止钱里之外的感觉。就是特别不能和他们真心交往。

Interviewer::我记得你给了 *Lost in translation* 5 分, 从文化这个角度来看, 你能解释一下吗?

GW: 就是有一个情节, 就是挺难以启齿的, 就是他那个男主角和女主角, 因为东经色情产业也很发达, 他们去了那个地方, 大街上, 就是, 东经应该是日本的政治文化中心, 可是象在北京, 就是觉得那种色情产业, 中国也应该有, 但是中国不会把它放在很大的太面上, 拿出来当一个正当的行当来经营吧, 可是他在那个大街上他们在走过商店的时候, 看到那个小姐穿的很暴露, 很挑逗的姿势在里面, 他们居然可以旁若无人, 当作很平常从旁边走过什么的, 然后我觉得这种事情在中国根本不可能发生。这就是大概日本人在那个方面特别开放的, 和其他亚洲国家相比较吧, 特别开放在那方面。[...]

Interviewer:: 那你从 *Lost in translation* 对日本人还有什么了解吗?

GW: 其实那个片子讲的还是美国人。

Interviewer:: 不管是美国人还是日本人, 你就说说吧。

GW: 我其实以前一直以为美国人他们历史比较短, 我觉得不会象中国人看什么东西都会产生对历史的感慨, 感怀啊, 见花落泪, 望月生情啊那种, 触景生情, 中国人经常会这样, 可是象那个女主角来到东经嘛, 对窗外的高楼啊, 自己在那里霞思啊什么的, 然后我觉得这看起来性格更象亚洲人。都可以在旁边做诗那种。就是感觉跟一贯美国人和西方人在亚洲人心中的形象有点差别吧。他们给我们的感觉就是嘻嘻哈哈的, 他们没心没肺的那种感觉, 只要今天快乐, 今朝悠久今朝最, 每天都活的很开心的那种。可是那个女主角她就是那个对人生岸标, 对人生有更高的境界和追求, 思考人生到底是什么样的, 还有自己的水球。给我的印象很深刻。

Interviewer:: 她让你觉得她和其他的美国人不一样是吧?

GW: 可能是我们平时对美国了解的很肤浅, 不够深刻吧。我觉得看这个片子的时候, 那个时候是在上高中, 不象在大学, 接触的外国人也有, 视野这么开阔。那时候就是感觉看这个挺触动的, 跟一贯的美国人在中国人的心目中那种形象定式就感觉完全不太一样。而且这个女主角特别喜欢日本古老的文化, 她去东经, 京都, 日本最具有古老文化的城市, 看日本传统的婚礼, 去寺庙什么的, 去求佛念经, 就是感觉特别触动, 就是外国人, 西方人对那些亚洲的文化也特别感兴趣吧, 挺触动的。[...]

GW: *Titanic*, 看的时候特别小, 记不得说的什么。

[...]

Interviewer:: [...] 我听说有的校园网有课件什么的, 在大学校园网上就可以看电影。

GW: 对, 我们学校没那个系统, 但是其他学校, 北大, 清华, 人大什么的都有校园网系统。然后可以直接在上面看电影。

Interviewer:: 你们不能上他们的网看吗?

GW: 那都是内部网, 都要经过学校认证, 连接才能上网。我们一般都网上下, 看到好的, 再去想买碟回来。然后经常看

(Interviewer: asks GW to indicate the ones she had deep impression on)

GW: *Titanic* 真的没什么印象了。那个时候特别小, 6, 7 岁吧。

Interviewer:: 说说 *Friends*.

GW: 最主要就是, *Friends* 在中国被各个大学的老师都强烈推荐。北京, 其他城市的大学基本上都会看 *Friends*. *Friends* 的碟在各大印象图书点都卖的挺好的。

Interviewer:: Why is it so popular that even teachers recommend students to watch it?

GW: 第一它比较长。拿来是一套配合学习, 也挺不错的。老师也挺推荐。感觉内容比较轻松, 说的内容比较贴近生活。然后就是比较长, 大家看 3, 4 年也看不完。

Interviewer:: Is *Friends* the most popular recent years?

GW: *Prison Break* 挺火。但是我没看过。

Interviewer:: 有没有什么清洁给你印象深, 或者出动你的地方?

GW: [...] 有一个特别奇怪的就是, 里面有一个女主角叫 *Phebee*, 感觉她就是行为特别怪怪的。而且, 他们 6 个人之间也有很复杂的感情问题, 这两个人在一起, 然后又分开, 然后又在一起。我就觉得在中国一般两个人在一起, 然后分开, 再见面都很尴尬, 他们还可以这样, 象没事一样, 一面可以共同生活, 还可以再符合, 我就觉得挺不可思议的。

[...]

GW: 其实我觉得他们(Ross and Rachedule)这种关系是满向往的那种关系。两个人感情到什么程度就怎么样那种关系。不用两个人分手之后还不能做朋友, 感觉挺尴尬的, 他们就是思想很开放, open。Open 和随意, 感情泛滥不一样。他们两个就是真心在一起就在一起, 不喜欢就分开, 凭自己真的感受, 对对方付出真感情, 没必要, 明明说, 象中国人要讲责任道义啊什么的, 明明不喜欢, 没有感情了, 还为了道义责任在一起, 为了孩子啊什么的, 我觉得没必要这样, 两个人既然没感情了, 就应该分开了我觉得。

Interviewer:: 那这个片子有没有告诉你一些你原来不知道的东西?

GW: 没什么特别大的印象。因为是室内情景喜剧, 大家的活动场所都在室内。没有涉及到美国其他方面啊什么的。

[...]

Interviewer:: 印象比较深的还有 *Gone with the wind*, 能不能说说?

GW: *Gone with the Wind*. 我看这部小说的原著。所以对这个片子印象特别深。高二下学期看的。同学推荐我看的。我以前对经典名著很反感, 所谓经典名著, 就是大家都说好, 确没有人去看的那种书。看完之后感觉故事内容挺吸引人的。就是战争背景下, 战争中那种爱情更加可歌可泣。而且女主角不是那种传统意义上单纯善良, 只会, 除了会恋爱什么都不会那种。她比较有心计, 为了保护自己的家园, 会在利益之间取舍。传统意义上的那种, 傻傻的, 除了谈恋爱, 只等男主角来的那种感觉特别不一样。

Interviewer:: 从文化这个角度来讲, 这个片子有没有让你对那个时期有一定的了解?

GW: 对美国的南北战争有一定了解。但是, 觉得就是美国贩卖奴隶啊, 因为 *Scarlett* 她们家有一个黑奴。但是我觉得, 没有想象中那么恶劣, 就是说贩卖人口啊, 感觉努力生活挺悲惨的, 感觉她们家黑人生活相对来说也比较不错吧。比较...就是, 战争年代, 挺惨烈的。以前之知道中国被侵略, 战争挺惨烈的, 觉得美国原来也发生这么惨痛的历史。

Interviewer:: 你刚才说到奴隶[...], 你为什么会有这种反差?

GW: 也许是, 我觉得在中国比较是, 怎么说呢, 中美文化差异吧。就象我们生活在中国这个地方, 共产党肯定会宣扬自己, 极力排斥西方经济文化体制, 吃人不吐骨头的体制, 中国宣传特意放大吧, 那种感觉。

Interviewer:: 那你是觉得这部片子纠正了了你的...?

GW: 思想吧。其实我觉得, 说中国被别的国家侵略, 其实中古在古代也侵略别的国家, 只不过, 每个人身在此山中, 不识庐山真面目, 在自己的国家政治文化气氛环境当中你就不能很客观的去认识自己的国家我觉得。其实我觉得出国留学也不是完全要学习希望文化和经济, 我觉得站在另外一个角度来审视自己的国家然后同时感受以下别的国家。

Interviewer:: 你为什么会有这种想法? 想站在另外一个角度来审视自己的国家?

GW: 我感觉在中国嘛, 还是挺没有言论自由的。就是中国一党执政嘛, 就不象其他国家有很多民主当派什么的, 我们的感觉, 而且我上大学对我触动挺深的就是 89 学潮啊, 文化大革命。我在上大学之前没听说国 89 学潮这回事。

Interviewer:: 你不知道?

GW: 我不知道。北方人谈政治比较多, 南方人比较清闲。来到这边听老师说过着方面, 听到后特别吃惊, 觉得共产党也会镇压大学生什么的。做一做什么暴力的事。所以我觉得生活在这个环境下我们还是被蒙蔽了感觉。

[...]

GW: 而且我也接触了日本的朋友, 我觉得中国对日本还是有很大的文化偏见的。

Interviewer:: 你刚才说到奴隶那方面, 是什么原因让你会觉得是咱们政府夸大了呢?

GW: 因为我对文化历史很感兴趣。对各个国家的文化都挺感兴趣的。换位思考吧, 因为站在别的国家, 别的文化, 比如说, 别的国家写些什么, 中国政府会说他们夸大了, 我想中国政府肯定在这方面也回。而且当时看了这本书以后也没想象中那么恐怖, 什么奴隶在那边没有人身自由啊什么的。他们家的下人还感觉挺, 有一个老奶奶, 就是 *Scarlett* 他们感觉很亲近的。不象我们历史书上描写的, 当时从非洲贩卖黑人过来, 死了多少多少人啊, 感觉特别悲惨啊什么的。因为那时候给我们的感觉, 所有的白人对黑人都是气压的感觉。可是我发现, 人嘛, 不管是哪个社会, 都会有好人和坏人。所以说, 就算是在白人社会, 象 *Scarlett* 她们家那种, 对下人特别和善。但是书中其实也写到了, 有时候 *Scarlett* 对那个黑人老奶奶特别反感啊什么的。但是我觉得人心都是善良的, 也是可以和平共处的。

Interviewer:: 你是从什么时候开始有换位思考这中想法的?

GW: 学日语吧。我爸爸以前学日语。我对外语很感兴趣的, 因为长大以后有个梦想, 以后想去宦游世界, 觉得学好外语很必要。学日语也很感兴趣, 爸爸也学过。在我这方面就有启蒙。学日语就会接触日本文化思想, 因为知道中国人和日本民族矛盾特别大, 在那种激烈的民族矛盾下通过对他们的民族文化了解之后, 我就觉得有时候中国人其实把别的民族想象的太坏了, 我觉得日本制造那么多事件, 其实是日本政府, 日本大多数人都很善良的, 我接触的那几个日本朋友都挺好的。所以我就会有时候看日本人对中国人的评价。就会产生换位思考的那种想法。[...] 而且那时候看 3 毛的书, [...] 通过她的视角看外国人觉得生活跟我们想象中不一样。

Interviewer:: 你什么时候开始学日语的?

GW: 我从初二, 初三开始的。但是上大学之后才把它当成第二外语。每周去上课什么的。

Interviewer:: 在你看过的这些片子中, 哪个片子让你对某个国家的人和文有了解呢?

GW: 看 Forrest Gump, 就是老师推荐的。也不止英语老师推荐, 心理学老师也推荐。所以这个片子在大一的时候看了 3 遍, 所以我印象特别深刻。但是看的时候就觉得 Forest, 人家说他是智障, 就是我觉得他, 老师也说过, 在那个片子里面宣扬的思想就是, 一个被感觉好象就是, 被上帝放弃的人, 天生有智障就是任何人都有闪光点, 在美国的社会很自由, 就象你这个人平常人身上看来很多不足啊, 但是只要身上有闪光点在那个社会就会被发觉, 会能得到自己的发挥自己的作用, 只要坚持下去。

[...]

GW: 看那个 The Shawshank Redemption 感觉印象挺深的。老师就放了两边。那个片子里面就是传达一种信念。而且我觉得, 看那个对我触动挺大的。明明是一个清白的人, 也可以被冤枉进监狱, 而且呆了那么多年, 在监牢里面, 监狱长欺压那些囚犯, 这种事情不禁发生在美国, 在中国也同样有。只要有文化社会啊, 社会体制啊, 别的国家有的情况我觉得中国也应该也有。

Interviewer:: 你刚才说要 Forrest, 只要身上有闪光点就会被发觉。那你觉得咱们中国呢? 象他这样的人?

GW: 我也不太清楚吧。

Interviewer:: 设想一下。

GW: 只要人身残志不残, 一直努力, 还是会被发现的。但是程度也许不一样。他在美国就受到大家很高的, 很大程度的好评。有很高社会地位。可在中国也许他只能算是过上正常的生活, 发挥到自己该有的作用, 别人也许不会有那种特别, 因为他是一个先天有残缺的人, 他现在努力了到这个程度, 因为他先天条件的不足, 给他特别大的那个什么, 就是他看到你努力到哪个层面上。不会因为你一开始起点很低, 然后你却可以爬到现在这个位子。对你特别的尊重, 我觉得应该不会这样。好象美国人不是单纯的看你的社会地位, 而且是看你的中间那段努力的过程吧, 中国人注重一个结果, 比如说你混到了一个科级, 处级, 不会认为你一开始起点是那么低, 在经过这么长时间达到这个水平已经是你付出努力, 他们不会这么看。就象有的人, 家里比如说有背景, 他可以混到这种水平和一个完全没有背景的混到这种水平, 大家不会用良种眼光来看带他们的我觉得, 都会还是一视同仁, 觉得一样。而不会因为你之前, 同样的高度你付出, 特别辛苦, 只提信念更强, 大家会对你更那个什么。我觉得在中国这个方面强调的很少。我个人也许有点偏见吧, 我也不知道。

Interviewer:: 说的很好。有什么说什么[...]

GW: 说的激动起来了。

(Interviewer: explains the background of the clip)

Clip 1: Friends – Rachel doing laundry

(After viewing)

Interviewer:: 有什么观后感?

GW: 这段我看过的。我就觉得第一点, 就是那个胖女人和他们争夺洗衣机。如果我觉得他们比较强调人权。强调自己的权利。如果我觉得这种事情发生在我身上, 我就是觉得息事宁人比较好, 因为旁边这么多洗衣机, 不要为了这个洗衣机的问题和其大人产生争执啊什么的。然后成为周围人瞩目的焦点。我觉得中国人就是那种中庸态度特别强。就不会愿意在公众场合让自己成为公众焦点, 不会那么锋芒毕露吧。中国人讲究韬光养晦。美国人就不一样, 他们就感觉, 觉得是自己的权利就一定要去争取那种, 不在乎在公众场合, 中国人就会觉得特别丢脸。他们应该这方面和中国, 东方文化有很大差异。Rachel 可以在 Ross 面前, 自己的贴身内衣可以拿出来, 洗什么的。而且他们两个当时还没有发展成男女朋友的关系吧。就算在中国是男女朋友之间的关系这方面也很尴尬很忌讳的。

(Interviewer: explains about the second clip)

Clip: 2: Friends – Lesbian wedding

(after viewing)

GW: 感想就是关于同性恋方面。这个事情吧，我就聊我周围对同性恋的看法吧。

Interviewer:: 你说吧。

GW: 因为当时我们上心理课的时候老师也出了一个心理测试题给我们。当时如果世界毁灭，会留下一些人，就是有一个人是同性恋，如果让他们选择如果留下一些人可以生存的话，就是问周围的同学。说老实话其实现在大学生对同性恋还是挺开放的。这种事情我们可以接受，但是发生在自己身上就是觉得可能性特别小，但是发生在别人身上挺能理解的。而且就是说，现在大学生里面同性恋挺多的。好象其实我们学校也有。所以我觉得同性恋，但是象他们这样能摆上正式场合拿去结婚的那个在中国不太可以被接受。你可以在地下秘密进行，但是拿到台面上大肆宣扬什么的，对家里的人来说肯定就会觉得没面子。

Interviewer:: 这个小片段有没有让你对通行连这个现象在美国有没有什么了解？

GW: 我不知道同性恋是从哪里发起的。当时因为日本漫画在全世界影响力特别大。日本漫画有一种漫画的分类就是‘单美’，就是同性恋的意思。所以那时候也看过那方面，但是他们把爱情写的特别为美，两个人都是精神恋爱啊什么的。所以我认为，知道这个也比较早。而且我们这代大学生对这方面也很开放的。如果再过十几二十年的话，象我们这么大的人，真正走向社会，社会真正靠我们这一代开始的话，就是这种现象在中国还是比较会被接受的吧。

Interviewer:: 那你觉得同性恋现象在美国，就现在而言接受的比较多？

GW: 其实同性恋在美国好象也挺不能被接受，不然 *Brokeback mountain* 怎么会里面写那两个男的在一起也挺遭家里人反对的。特别是他们那种，一开始结婚了，然后又变成同行恋，感觉有双性恋倾向那种。象他们肯定不会太接受。但是我觉得，这方面我觉得，中西方还是有点共同的吧。其实我觉得美国这个社会，不一定所有的人都能接受这种现象吧，中国也是。就是老一悲的人吧。就象我们大学生身边的人，这些我就觉得可以接受。他们说，都是爱，只是爱的对象不一样。

Interviewer:: 你对那个 *Brokeback mountain* 怎么看？

GW: 没看过。那时候中国不让播。

Interviewer:: 对，不让播。我都碟哦！

GW: 我同学也有。就是感觉啊，我买的 *Creazy English* 里面有截的片段，就是哪个 Jack 死了，另外一个人到他家里和他父亲谈话，但是杂志对他的评价就是这部电影就是有很重的美国西部口音，就是觉得学英语的话听那个挺费解的。也没怎么看。

Interviewer:: 你知道 *Brokeback mountain* 拍的是关于什么年代片子吗？

GW: 不太清楚。反正不是现代的对吧。应该就是 80 年代，90 年代西部牛在的感觉。跟现在可能还是不是一个年代吧。

Interviewer:: 那你刚才说，*Friends* 是现代的片子。*Brokeback mountain* 是关于比较远久的事情。有没有让你觉得在那个年代不接受，但是在现在的年代可以，你刚才说，他们都有反正美国同性恋方面的问题，那你说。。？

GW: 我觉得中国现在就有点象 *Brokeback mountain* 那个年代的时候。发展个再过十几二十年，也许就会发展到象 *Friends* 里那样，大家对待同性恋态度一样。最起码我们这辈人大家都可以接受这个现实了。因为我身边好象没有人反对同性恋的。就是觉得特别恶心啊，什么的。然后我有个同学他就是学漫画的，里面全都是同性恋的女生，他就在里面常常混水墨女在里面说什么，她不参与，就是那里听。就是觉得我们这一代人对同性恋还是比较开放吧。也许过了十几二十年后都可以接受，结婚啊什么的。就是中国法律也没有说同性恋可以结婚，不知道美国有没有法律同性恋可不可以结婚。但是中国人应该法律上还不承认这种关系。

Interviewer:: 那这个小片段还有刚才放的小片段有没有让你对美国人有一部的了解呢或者认识？或者你你原来有的认识，这个片段让你进一步确认了，有吗？

GW: 我觉得美国人思考的角度和别人不太一样。我觉得，什么都是相对而言的吧。每个地方和国家都有自己的文化，都有自己的意识形态。他们也许在他们那边，中国人当时，美国人总说中国人没有人权不平等什么的，可是如果想象一下，真正把美国那种所谓的平等自由，拿到中国来的话不一定也能行的通。国庆不一样嘛。不能说让大家跑到天安门广场说什么反对毛泽东，反对胡锦涛，不太可能。(critical) 象在美国，大家可以在白宫面前反对布石，但是这种动词拿到中国来不一定行得

通。我觉得中国也相对比较自由。而且，中国人没有那种，要求言论自由的欲望不是那么强。没有人会想着没事干去天安门广场，反对胡浸涛。在这方面，表达形式不一样，美国人口头化，表面化，平等自由什么的。美国人说中国人没有自由，生育自由都没有，计划生育什么的，可是考虑到中国的国情，如果不坚持计划生育的话，已经资源很匮乏了，竞争压力，就业压力都特别大，如果当时再不控制的话，肯定没法活了，所以美国人老说中国人没有自由，但是国情不一样，他们出发点肯定和我们不一样。他们追求的跟我们不一样。

[...]

Interviewer:: 你没看过美国派?

GW: 没有。

[...]

(Interviewer: explains about the background of the clip and the film)

Clip 3: American Pie –Virgin Deal

(after viewing)

GW: 我跟你讲一件事情，对我触动挺大的。我上大学一年了嘛，高中毕业之后一年多时间，家里同学没见面，回家见面聊天，就发现，现在好多大学生对性这方面非常非常开放。我不知道，其实我那些同学吧，她们都好多已经发生关系了。

Interviewer:: 你是说女孩子?

GW: 女孩子多，男孩子也特别多，最让我吃惊的就是好象是我初中的同学吧，男生没谈过恋爱的，他们说屈指可数就 3, 4 个了吧。

Interviewer:: 上了大学后就突然...?

GW: 上了大学之后就突然那样了。我觉得我当时挺被蒙蔽吧，我觉得高中那个时候学的是理科，特别呆，每天就知道做数学，物理化学，疑心住读圣贤书，两而不闻窗外事。对班上那些情况都不了解，一个年纪，十几个班，文科班的感觉比我们理科班的要开放一些。而且他们课业不象我们这么繁重，有些事情，有些男生女生发生关系是在高中啊，初中也有。

Interviewer:: 你们南方是不是比北方开放?

GW: 南方比较开放，比北方开放多了。我有个同学就是广州的，说男生和女生在卫生间发生那种关系。他们都是高中生。[...] 姐姐你可能出国好久，可能不了解。以前在高中都不说这些事，现在大家都上大学了，回家有男生女生在一起说，他们也会说到哪个男生和哪个女生在一起啊什么的。在一块同居的也有，就是大学生。[...] 有些男生也挺保守的，非处女不娶啊什么的。

Interviewer:: 这种人还寻在啊?

GW: [...] 不过现在大学生还是挺开放的。不过我还是挺保守的。第一我觉得爱情是精神产物。两个人不能因为空虚寂寞，现在好多大学生谈恋爱，他们说，归结起来五个字，耐不住寂寞，我觉得我不是那种人，我一定要找到我的珍爱。大家起码心灵要契合，有共同的思想，未来的发展，人生目标，全该一样吧，不然在一块也是短暂的。 [...]

Interviewer:: 这个小片段有没有让你对美国的高中生有一定的了解?

GW: 我觉得挺那个什么的。因为我一直就觉得欧美那些人在那个方面挺开放的，结果没想到他们在做那种事情之间还得经过一番思想挣扎。还要达成协议什么的。在我想象之中他们应该是想到那种，我记得原来看过一个片子，美国人在纽约，里面有降温吧，他演的爸爸，他的女儿交了一个美国男朋友，他们两个发生了关系，结果那个对我挺触动的。

Interviewer:: 哪方面?

GW: 就是她和她的男朋友在美国发生关系后，那个男生，她毕竟是从中国过去的女孩子，然后就对那方面就特别，想啊，那个片子很早很早了，最起码 10 年以上了吧，那个时候美国高中声就可以了，在那方面，当时我觉得...

Interviewer: 那个女孩子最后怎么样了?

GW: 那个女孩子还是和他发生关系了。

Interviewer:: 然后呢? 以后我就不记得了。

GW: 那一级给我印象特别深。这两个人，他们两个一开始就是在房间里，嘻嘻哈哈，结果那个男生把那个女生拉到床边，结果那个女生就很迟疑，惊慌失措，不象那个男生还那么自然，就觉得好

象挺应该的，那个女生就觉得特别，…就是东西方文化差异吧。男生就不会认为有什么。而且现在在大学里面，有很多男生也包着和这几个男生一样的想法，摆脱处男的帽子。

Interviewer:: 有这种人么？

GW: 有,有! 现在大学生挺开放的。南方大学听说更开放。[...] 在北方好一点，我觉得北京学习气氛还挺浓的。

[...]

Interviewer:: 你看过 Crash 吗？

GW: 听说过啊。听说获奥司卡奖了。但是高三没时间看。

(Interviewer: explains about the films and the clip)

Clip 4: Crash – Director

(after viewing)

GW: 我大能了解一些。我就觉得这两个人吧，这个白人，拍电影当中黑人说了一句话，然后他就觉得那个黑人说的话不符合黑人的表达方式，他用了白人表达语言的方式，他就觉得预约了他的身份和肤色。然后他让他该过来。但是我觉得他是，要求改的是个白人吧？

Interviewer:: 恩。

GW: 他有自己的种族的文化，他也许就是挂念里面还是有一些 discrimination 其实。然后他就得强迫，他就感觉，我们那个时候老师跟我们说过，很多人就喜欢贴标签，把一类的人归到一类，就是说我们一谈到英国人，就觉得很绅士很古板什么的，就很容易刻板印象给人家贴标签。属于那种，谈到黑人，他就觉得黑人就得用这样的方式说话。这就是文化冲撞吧。但是因为这个导演他自己是个黑人，他就很能理解这个黑人说这种话的感觉吧。两个人之间产生矛盾和摩擦了。我觉得这个白人还是对黑人有很大偏见的。感觉象中国古代那种说话也是分等级的啦，就是皇上才可以叫朕，叫寡人什么的，不能预约身份还有等级地位。在他们那边反映在肤色之间那种，不能越过界限吧。表达不清楚。

Interviewer:: [...] 那你说这个黑人导演一开始为什么没有想到白人导演想到的东西呢？

GW: 他自己生活的就是在黑人的背景下，文化氛围吧，他自己觉得一种很正常的表达方式，也许在不同的种族的人看来就是一种非正常的表达方式，他可以理解，因为他有相同的背景文化啊，也许他在生活经历中出现过同样的事，他可以理解自己的同胞，说话啊，思维想法方式啊，我觉得很顺的一句化。但是在别的种族的人站在他们的视角来看就不太一样了。

Interviewer:: 那你觉得他后来为什么又同意了呢？

GW: 不想发生摩擦吧。还有一种妥协吧。和这个白人导演发生摩擦啊，就是觉得合作就 compromise, 就得妥协。

Interviewer:: 那你说如果那个黑人演员不改过来，就这么说，如何？

GW: 对，我觉得没有必要一定改过来。

Interviewer:: 那你说为什么一定要改？

GW: 就是说艺术来原于生活但是高于生活，如果他这样一改，就会把片子当中，黑人的文化和白人文化区分的更明显一点吧。这样大家就更容易发现其中的差别。

[...]

Interviewer:: 我突然想起来了，既然你这个喜欢学英语，你觉得在学习外语的过程当中，哪一方面比较重要？你觉得对于说英语国家的文化了解重要吗？

GW: 很重要我觉得，因为，比如说一个单词的意思，它在那个环境下说出来，如果你对他的文化了解的话，即使你不知道他的意思，通过他们的思维方式或者文化背景就可以猜出来大概的意思。这方面有点惭愧，就是我在学英语的时候体会的还不是特别深刻，我学日语就特别体会这一点，[...] 有时候老师语法明明说一个词，[...] 我在做题的时候下意识就反映是这个意思。[...]

Interviewer:: 既然你觉得文化比较重要，在英语课堂中，那你觉得用电影帮助教学的手法你喜欢吗？有什么说什么。

GW: 我觉得什么事情都有两面性。她放这个是可以，但我觉得要适度，而且要荆条西选，有时候我就觉得，因为电影也不是完全能够真实的反映一个国家，就是你，对美国可能不了解，但是对自己国家了解，你看中国一些影片，难道就彻底的反映中国的国情吗？所以我觉得有时候放的一些东西，

不一定就是真实再现了一个国家的风土人情吧。我主要乐意看书什么的。所以我就想以后要亲眼体会以下。不想通过别人的视角来了解。

Interviewer::那你说的精挑细选指的是什么?

GW: 挑一些贴近生活的, 真实的, 不要艺术加工那么, 色彩那么太强烈的。

Interviewer::有没有哪布片子, 你推荐一下?

GW: 电视剧吧, 我我觉得 *Growing Pains*, 小鬼当家, 也挺逗乐的。我觉得 *Growing Pains* 挺贴近生活的, 感觉特别真实。象那些事啊就象发生在自己身边一样。然后 *Princess Diary* 灰姑娘变公主, 的确很少, 而且也有童话的意味在里面。但是想 *Growing Pains*, 还有 *Friends*, 就真的是生活中每天都有这样的事情发生。小的事情都能体现出来。

Interviewer::那你觉得我们今天看过的片段如何? 有没有文化价值?

GW: 我觉得不错。我就觉得象这个 *Crash*, 他是以 *Discrimination* 为什么视角。我们在看这部电影的时候, 觉得就不能把他放之四海接准, 但是我们知道他存在这种现象。我们应该通过这个现象看的更广一些, 不能死揪住一个点来看。这样看来就是美国社会中确实存在, 但是你也看到一些为了消除歧视啊, 美国人做出的努力。我觉得不能单看一个方面。就是电影毕竟是浓缩的, 它回把不同的, 他想体现他的主题的事情放在一起, 罗列在一起, 可是你也要看到他没有选择的那些。但是也是存在的一些东西。

Interviewer::你平时看电影会不会往这方面想?

GW: 会吧。特别是看到那些主题浓重的, 就是特别中国人跟日本人, 日本影片啊, 看的时候就是中国老是说日本多暴力多饿殍什么的, 有时候我就想到, 其实真正和我交往的日本同学他们是什么样的性格, 不是每个日本人都是那样。但是我跟英美国家的人交往太少了, 然后他们, 毕竟隔的也挺远的。平时交流不象中国和日本, 虽然有矛盾但是交流的还是多一点。所以以后如果有机会, 我一定要出国, 亲眼看以下, 认识一下。

Interviewer::说的好, 非常好。太感谢了。说的很好。

(end of interview)

Appendix 7: Sample Group Interview Transcript

(interviewer talks to interviewees very friendly to let them know to relax and be honest to the questions, do their best to tell the interview what's in their minds; then let each of them introduce themselves; asked them whether they are used to the lives in Beijing. After S4 introduced himself, the interviewer asked the girls to speak more loudly so that to ensure the recordings clear, everyone laughed. The atmosphere was pretty friendly and relaxed.)

[...]

Interviewer: 根据你们的大学生活，你觉得学习英语重要吗？

S2: 重要。

Interviewer: 说说为什么？

S2: 因为我觉得，英语是一个重要的交流工具，因为比如说你要和别人交流，象现在，我到你们学校来，看到好多外国人，可是我就是不敢上去和他们说话。[...]

Interviewer: 其他人有没有要补充的？为什么重要？

S1: 我觉得英语重要是因为社会压力。因为毕竟现在中国发展，越来越大了，要和世界接轨就必须学英语，高中还不觉得，高中的英语就是死的，整天就是作题，对自身英语没有什么作用，到了大学以后要求和以前不一样了，是全方面，不是光作题就可以了，大学毕业要考 4 级，这样是一种压力。[...]

S4: 我大一的时候对英语的重要性理解的不够，但是上大二之后由于教材什么的，利息理论什么的，都是用英语写的，所以我觉得要把英语搞好，因为首先第一点以后研究方向上，很多资料都是和英语有关。如果有更多的发展应该和世界上各个国家不同领域的人交流，比较现在世界上用的最广泛的官方语言。

Interviewer: 你还有什么要补充的吗？

S3: 我和他们讲的差不多吧。

Interviewer: [...] 学英语，有听说读写这几项技能，对吧？那么你说，对于学英语国家，说英语的国家，比如说，澳大利亚，美国啊，英国啊，对这个国家和人的文化进一步的了解，你们觉得重要吗？你们个人认为，是什么样的？

S3: 我就是感觉没有什么重要。

Interviewer: 解释一下，为什么？

S3: 老师讲多少就是多少了，没有想说去了解。

Interviewer: 说的好。那你觉得呢？(looking at S1)

S1: 学的时候没有意识到，[...]

[...]

Interviewer: 你们上大学是 4 年都学英语还是？

S1-3: 两年。

Interviewer: 那大三大四怎么半啊？

S2: 自己看。

[...]

Interviewer: 根据你们自己的经验，有什么说什么啊，根据自己的真实感受，在你作为大学生学习这一年多，在你课余时间啊，在你学习过程当中，对于说英语国家，特别是美国和英国，也是咱们中国同学接触比较多的。你们主要是通过哪些渠道呢？

S1: 看电影。

S2: 对，看电影挺多的。

Interviewer: 恩，你呢？

S3: 差不多。

Interviewer: 你呢？

S4: 看新闻。

S2: 哇，好厉害。

Interviewer: 看什么样的新闻？

S4: 就是看新闻联播，了解外国的事情。

Interviewer: 你是说中央电视台的新闻联播？

S4: 对，但是如果就是针对英语语言学习的话还是看电影，或者看 CNN。

Interviewer: 你们能收到 CNN, 对吗？

S4: 不是。可以买。可以买光盘看。

Interviewer: 哦！

S4: 对，在个大书店都可以买。

[...]

S4: CNN 好象是英国的。

[...]

Interviewer: 你们这能买到 BBC 吗？

S4: 能，可以。

[...]

Interviewer: 在日常生活中啊，你们三个人刚才说道电影，什么电影，解释一下？

S3: 我比较喜欢看好莱坞那些。

Interviewer: 好赖物的，大片？

S3: 狮子王啊什么的。(giggles)

Interviewer: 是属于别人推荐还是哪个抄的热就怎么样？

S2: 差不多就是抄的热。

S3: 差不多就是抄的热，有的时候自己想看的话。

S2: 还有些老片，比如乱世佳人啊，罗马假日。下下来想看一下啊什么的。

Interviewer: 为什么想看这些片子？

S2: (immediately) 因为我觉得它比较经典嘛，经典一定会有他的原因的。

Interviewer: 哦！

S2: 对吧？大家都赞同它，它肯定有他的价值。而且我看了一遍我都没舍得删，我觉得挺好的。

Interviewer: 为什么觉得好？

S2: 乱世佳人对吧？

Interviewer: 啊。

S2: 我觉得表现那种挺深刻的，就是那种战争的残酷，还郝思佳的坚忍。它也挺漂亮的，而且它也从不同角度反映了南北战争。

Interviewer: 不同的角度反映南北战争？说的再详细一点。

S2: 因为你看，在历史上说的话，南北战争是北方是工业嘛，南方是种植园，所以北方比南方先进，就是比较支持和赞同北方，虽然我不知道这段历史，其实我没有细研究过，应该这是说，也许吧，战争不可能是哪一方是对的，哪一方是错的，这样子是不可能的，但是总体来说，北方先进，南方落后，那也是正常的。也是历史的必然。但是它那个电影说的就是南方的人，也反映出这个战争在给这个国家带来先进的科技的同时，把它同化以后，也给南方一些美丽的土地啊，还有庄园造成了很大的损失。

interviewer: 你是觉得和你在历史书上学到的有反差是吗？

S2: 对对，就是从不同侧面去了解这个事件。

Interviewer: 恩，有意思。那你的，你还有没有什么要补充的？

S1: 没有。

S3 & S4 (silence indicated had nothing to add)

Interviewer: 那我问你们啊，你们如果去获得这些电影呢？

S2&S1: 网上下呗。

Interviewer: 网上下载?

S3: 下载。有时候电视频道播的时候有时候会看。[...] 老友记也播过。

Interviewer: 那你看电影多吗? (looks at S4)

S4: 有时候看。主要看老有记。我就感觉 Friends 很生活化, 挺实用的, 也挺搞笑的, 挺有意思。

interviewer: 你们都看过老有记吗?

S2: 没有。

S1: 没有。

Interviewer: 现在还下得来吗?

S3: 肯定下得来。

S4: 用迅雷那种。

Interviewer: 我问你们, 你们平时怎么看? 是听英文和英文字幕, 还是中文字幕, 还是没有字幕?

Ss: 一般都是英文, 中文字幕。

S2: 对。

Interviewer: 为什么呢?

S1: 因为下不到英语字幕的, 普遍都是有中文字幕。(S2: 有中文, 对), 然后是英文。但是一般是看中文, 英文就是耳边过的那种。

S2: (laugh) 如果能听的懂就挺英文, 一般长句子都看中文了。

S3: 看汉语了, 恩。

Interviewer: 你们看英文和中文字幕, 一遍能看得懂吗?

S2&S3: 一般都能看懂。

interviewer: 那你们如果看英文和英文字幕呢? 能看得懂吗? 试过吗?

S2: 我看过电影频道的, 看过一两次, 看不下去。哈哈。因为它那个, 本身我英文也不是特别好, 也不是特别好, 几乎是不好。因为是, 日常说话, 可能就比较快, 特别是长的句子带连读什么的, 本来听就很费劲了, 再就是英文, 然后说特快, 刷刷刷就没有了。根本就是看不懂, 有的地方就很模糊, 如果在电脑上看, 来来会回还可以再看看。电影频道就不行, 放了后就没了。

S1: 我昨天正好看了一部英文电影, 中文和英文字幕都没有。就是很小很小的句子都还懂, 然后就主要看情节。而且那部电影是我小时候看过的, 我知道情节, 我偶尔能挺的懂几句小的句子, 心里面还有点惬意, 但是长的句子就不懂了。(smiles and shy)

Interviewer: 那你呢?

S4: 有时候很多地方可能不懂, 但是看了两三遍就会有一个更深一点的理解。

(interrupt) Interviewer: 你是说看英文的英文字幕?

S4: 恩, 对。在电影中出现的句子, 虽然比较经典, 但是他那种生词量还是比较小的, 它都是比较生活化的词, 所以看两三遍还是可以的。

Interviewer: 那你们如果可以选择的话, 你记不记得在问卷当中问过你们, 如果你可以选择的话, 你们比较喜欢通过哪种渠道?

S1: 电影。

S2: 还是电影。

Interviewer: 为什么呢?

S1: 因为有图有声音。不会很枯燥, 容易把我们吸引住。如果看文字的话就睡觉了。

S2: (laugh) 就等于催眠了。

S2: 而且我觉得电影吧, 你看, 它就是说话对着屏幕, 口型, 表情, 你都可以去学, 去学原声的感觉, 怎么说英语, 在日常生活中, 用英语表达情绪啊什么的都可以。这个不错。

Interviewer: 那你呢? 你有什么看法? 你是比较喜欢哪种渠道? 你个人认为, 你个人的感觉。

S4: 我感觉有外国人交流最好了。很生活化的。

Interviewer: 那第二种选择呢? 间接资源。

S4: 如果要是学口语的话...

Interviewer: 我是说外国文化。

S4: 上网。

Interviewer: 为什么呢?

S4: 因为网络上关于外国事情很多, 这些媒体有很多关于外国的, 这些媒体肯定是加工过的。

Interviewer: 那你说哪个是加工过的?

S4: 就是电视啊, 尤其是国内的电视。

Interviewer: 哦! 加工过的。

S4: 但是通过网络的话, 可能会了解的, 一个是从范围上更多, 另一个是更原始, 更真实。

interviewer: 那你都看什么网。还是只是觉得网络很好, 但是没有具体去看过?

S4: ... 反正我自己也是学经济学专业的, 上外国的经济学网站比较多, 但它也不是很生活化, 只是很专业领域的。

S1: 我有补充。

Interviewer: 你说说。

S1: 如果是外国文化的话就是记录片吧。[...] 我觉得这比电影好, 你看电影主要看的是情节, 很少会接触到它的文化。

Interviewer: 在现有的资源里面, 哪种比较方便, 直接?

S1: 也就是电影吧。

S2: 只要是能在网上下载的就比较容易

Interviewer: 你们现在都下什么, 大片?

S3: 大片。

S1: 对, 基本上你想下的都能下。

S2: 因为知道的也不多, 外国的电影, 就象中国出的小电影我们还不知道, 外国出的小电影我们就更不知道了。只有那些宣传力度很大的那种我们才能知道。所以, 有那个需求才会有目标下那个电影。 [...]

(interviewer explains about the film cards, and gives instructions)

(while students filling in the film cards, sometimes they talked to each other)

S3: 你们谁看过那个勇敢的心? 我怎么觉得我看多啊?

S4: 勇敢的心...

S2: 我看过。看过开头。开头可恐怖了。好象人都变成都干尸了好象。

S1: 没有。是因为这个小孩。

S3: 勇敢的心讲的是不是 3K 党啊? 这个我知道啊。

S1: 这个小孩。

S3: 是不是有 3K 党啊?

S1: 不记得了。

S2: 不记得了。

[...]

S3: 我看的最多的就是阿甘正传。

S2: 哈哈, 阿甘。

S3: 我们的阿甘。

[...]

S3: Queen 你看了吗? 女王?

S4: 没有...

S2: 看过, 我们英语老师让看的。[...] 那个女王其实挺那个的...

S1: 很凶。

S2: 但是很有气质的。

S1: 有气质有什么用啊。

S2: 有用的。

[...]

S1: 我们宿舍有人叫你 Forrest Gump.我觉得你们的气质很象。

S4: 我吗? (laugh)

S1: 你和那个 Forrest Gump.

S1,2,3: (giggles)

S4: (giggles)我们班确实有一个 Forrest Gump,但是不是我。

S2:谁?

S3:谁啊?

S2:天啊? 和我们呵甘一样诶!

S1: 叫什么啊? 看看我们认不认识。

S4: YY,认识吗?

S1: (immediately) 哦, 我认识他, 我们是一个宣传部的。

[...]

S2: 我觉得他牙齿好白啊。

S3: 谁啊?

S2: 汽车总动员。

S1: hahaha

[...]

S1: 你觉得这 4 个女的谁好看?

S2: 都不好看。

S3: 哪个?

S2: 欲望都市。

[...]

S3: 我就特别喜欢啊甘正专。尤其是他跑步的时候, 我就觉得他, 诶呀怎么那么好啊!

[...]

Interviewer: 你们老师给你们放过女王是吗?

Ss: 恩, 对啊。

Interviewer: 播的目的是什么?

S3: 目的就是教英语。

Interviewer: 那你们喜欢吗? 女王这部片子?

S3: 我觉得还行。

S2:我觉得..还不错。(group influence)

Interviewer: 有的同学跟我说没看懂, 你们看懂了吗?

S3: 看懂了呀。

S1:有点象记录片。

S2:对有点象记录片, 不是很, 就是说也许我们理解的和它要表达的意思不是很一样吧。

S3: 这倒是。

S1: 而且我们看的是英文的。

S3: 我们看的时候就觉得跟英语老师讲的很象。

[...]

S2: 没中文你看的懂吗?

S1: 看不懂。可是我看的时候就没看懂。

S3: hahah, 一直都没看懂。

interviewer: 看完这部片子后的感觉如何?

S1: 就是那个女王比较有气质。也算是讲的时事吧, 讲的是 Prince Charles and Princess Diana。本身带按捺多王妃都听多了, 但具体也不了解, 看了看还是稍微有点了解这两个人的爱情。

S2: 恩, 知道了很多。而且也对英国王室也有一点稍微的深入的了解, 看了看 Bukim Palace 是什么样子。

interviewer: 那你说刚才对 Prince Charles and Princess Diana 的爱情故事, 你都了解到了什么? 你还记得住吗?

S3: 这个我以前看过, 带按捺王妃死的时候, 有很多书嘛, 关于他们两个的, 我看了。一开始是一个老师, 但是最后他们两个结婚了。但是这个电影吧, 我就觉得那个女王挺难的。就是很辛苦的那种我觉得。

Interviewer: (smile) 很辛苦?

S2: 就是活的不是很自由。有的时候必须伪装的活。其实我觉得他们不是不喜欢 Diana, 而是破于一种压力, 不能表现他们的感情。

S3: 对。

Interviewer: (looks at S4) 你看过吗?

S4: 我没看过。我和她们英语班不是在一起上的。

S1,2,3: (laugh together)

Interviewer: 那你说说老友记, 你看多少了?

S3: 大概看了两季吧。

Interviewer: 喜欢吗?

S4: 挺喜欢的。

interviewer: 有没有印象比较深的?

S3: 那个... 男主角叫什么?

Interviewer: 有三个男主角呢。

S4: 那个追求 Rachel 那个。

Interviewer: 哦, Ross!

S4: 他追求的过程。

Interviewer & all three girls: 哦!

Interviewer: 你在他身上能够学到一些什么还是什么? 为什么对他印象这么深啊?

S4: 也不是学到。就是, 他在追求, 一直被拒绝, 当他离开 Rachel 后, 在 Rachel 内心里也有波动, 它与整个 Friends, 因为整个 Friends 反映的是很生活化的, 带有一点轻幽默性质的。但是他在其中能够体现出这些东西, 我感觉挺好的。

Interviewer: 哦! 那你的? 你看过老友记对不对?

S3: 看过一点。我就觉得很好玩, 其实别的就没什么了。

Interviewer: 没有什么了, 是不是?

S3: 就觉得很好玩。挺搞笑的。

Interviewer: 我看你们都看过 Titanic, 喜欢吗?

S4: 喜欢。

Interviewer: 为什么呢?

S4: ...

Interviewer: 印象深吗? 为什么深? 哪深?

S4: 大概有两个场景比较深吧。一个是男主角教他怎么吐痰。往大海里面吐痰。另外一个当船沉了以后, 女主角躺在木板上, 男主角在水里支撑着模板, 最后活活冻死了。挺感人的。

interviewer: 那你说吐痰那个, 你为什么印象这么深呢?

S4: 因为我感觉女主角是出身贵族, 是很高贵, 很讲礼仪的家庭, 男主角是一个等于是出身于市井, 很社会化的, 两种社会背景很反差的人, 通过, 其实我感觉他们这种爱情就是从那个时候开始的, 虽然短暂但是非常深刻。

interviewer: 那你们有没有对于那个镜头或者片段记的比较清楚的?

S3:就是那个女的要从船上跳下去,被那个男的拉回来,把我吓死了。

Interviewer: 哦,其他的呢?还有吗?

S3:还有那个开枪自杀的那个,船上的那个。

Interviewer: 哦那个人啊。

S3:还有那个乐队。

S2:哦对.别人都在逃生,他们还在演奏 (S1 & S3 agree),我觉得他们好厉害。

S3:挺厉害的。

interviewer:怎么厉害?

S3:就是感觉不象我们,跟我们有差别。我觉得跟我们有很大的差别在这方面。

S2:其实人到生和死的边缘的时候,你一下子看开了,就什么都不害怕了。

interviewer:你刚才说很大差别,是什么意思?

S3:我觉得就是不一样。象我们的警察位置秩序嘛,就是他可能是杀了别人,然后他就把自己杀了,然后还有那个乐队,我觉得这要是中国他就会。。。他们就是那种很浪漫的感觉,而且他们追求那种感觉我觉得那个乐队挺好的。印象很深,反正感觉不一样。

interviewer:你想说什么 S4?

S4:整个的场景,那种两种场景的对比,一个在 80 年前的传上,另外是在 80 年以后,当女孩子成为 100 多岁的老太太的时候,她那个当时的反映,当她就是很平静微微到来那个故事,还有当最后男主角对女主角说,你会或的很长寿,我感觉那种,虽然话语很平淡,但是我感觉有一种精神的震撼。

S3:我觉得他们就是我们选择不一样。象中国的话,他也许就双双去死了,但是他们还活了一个。

S1-3:中国人就是要殉情嘛。

S3:而他们就活了一个。我就觉得这个很不一样。

S2:对于生命的观念不一样。

S3:对啊,就是对生命的。。。你看他们就活了一个。你看我们,肯定两个就全都死了,象梁祝啊。

L:那你觉得是什么观念呢?

S2:我觉得他们应该还是比较珍惜生命吧,就是活着就是一种资本。象中国人比较情绪化一点,好象没有那么理性。是这样的吧,好象现在都这样说。象中国人吧,都追求一种,人性啊,或者是人的感情上的一种超脱,梁祝啊。文学作品中就可以看的出来,大家都喜欢两个人到了最后就殉情。就觉得这样很美,最后话成蝴蝶什么的,就感到很浪漫。但是他们呢,就是很坚强,有生的希望就绝不放弃那种。就是说,他们不会说很傻的两个人,哦,我还能活,但是我还是和你一起去死。但是那个,如果是爱的话,他希望他爱的人能或的更好。

Interviewer: 哦!

S4:其实我感觉良种情感都挺深刻的。

S2:都挺不错的。

S4:一种是中国的梁祝的殉情,以一种对爱情的忠贞啊。在外国他那种经过若干年后,有一个青春的小女孩变成一个老太太,她依然能那么平静回忆这件事,依然希望在心中有这颗种子,我感觉也是一种很深的就象是那种涣涣流动的长河一样。

(all the girls, including the interviewer, were impressed by his Chinese, very beautifully put)

[...]

Interviewer: 还有还补充的吗?

S1:我觉得那首歌挺好听的。然后还有他们救人的时候就是 Lady first,小孩和女孩先走,然后因为可能在中国的话,毕竟自己也没有接触过这种事情,但是看外国这种救人的时候总是男生,男人总是站在最后,让女人和孩子先走,就觉得他们,好象这是他们的一种传统,只要遇到事情,就是要女孩和孩子先走。有点羡慕他们这种传统。(S2 laughs)因为中国表现的不是很明显吧,起码我觉得没有他们那么强烈。然后我看到这里印象挺深的。然后我对于外国人的话,我觉得他们是比较热爱生命的。也热爱生活,我觉得他们的生活是一种自我价值实现。不象中国,我觉得中国是一种责任,更多是一种责任。

S2:恩,对对对。

S3:我还想起来他就是上船的时候他好像是赌博赢了钱去的对吧?直接就去了。我觉得要是中国。。。想干点什么就直接去玩了,我就觉得挺少的。哈哈

S1:他们挺择性的。中国人肯定就把钱自己留着,或者给家里人存起来。

S3:直接就拿着包跑了。

S1:不会象他们那样洒脱。

S2:传统观念不一样。西方人毕竟不一样。就是差异。

S4:因为我感觉 Titanic,有依据统共植苗的还有一部经典的 Waterloo Bridge, 看过吗?

Interviewer and all the girls: 哦, 混段蓝桥。

S4:等于是 Titanic 男女主人公换了个各,若干年后,男主角再去回忆。另外我感觉他就是很具有浪漫性质的。他 Titanic 恋爱都是很闪电似的,但是爆发出的那种情感确是那种非常深厚的,非常浓烈的那种。

Interviewer: 在你们看过的这些电影电视剧中,有没有哪个让你觉得,诶,让我对当地的人啊,人土人请,从文化这个角度来看吧,有一些信息,就是有一些了解的?

S3: (immediately) 啊赶正转。

Interviewer: 哦!

S2: 历史性比较强。

S3: 我觉得 Forrest Gump 里面就是什么都有了。从水门事件, 对吧(S4: 哦对对), 还有刺杀总统, 南北战争

S4; (interrupt) 越南战争。

S3: 哦, 对对, 越南战争。什么都有了! [...] 高一的时候就看过了, 那个时候老师就是为了让了解文化。[...] 大一来了后又看了一次, 大家一起看吗, 所以印象很深刻。

Interviewer: 你想说什么? (to S2)

S2: 我想说也是, 比较系统一点吧, 时间都有了, 地点都有了, 很详细。而且, 他让主人公去亲身经历, 虽然有点演绎的那种色才, 就是搞的很搞笑, 很戏剧化, 但是好象电影带这你一起去经历一样。这部片子拍的挺好的。还有就是 Gong with the Wind, 也是历史方面的。

其实我觉得要是真正能反映他们文化或者是背景之类的还是比较历史一点, 和历史有关的那种电影比较好一点。象 Harry Potter, Pirates of Carobean, 这类的我觉得他就不会是很反映一个国家的文化, 因为他们就是 (s4:对太科幻了, 在现实生活中不存在), 我们去看了以后, 就觉得哦这是英国人的生活, 不可能, 就象如果说, 英国人都是魔法师啊, 不可能。

Interviewer: 那你们觉得 Friends 呢?

S2: 这种也可以。比较生活化。细致的方面 (S4: 对对)。

S3: 还有一个, 我忘记是什么了, 好象就是两个兄弟, 还有爸爸妈妈, 我忘记是什么了, 也就是类似的这个, 和 Friends 差不多的。就是他们家里人的那种关系。

Interviewer: 你还有什么补充的吗,Forrest Gump or other films?

S1: 因为现在电影看多了, 也记不起来了。但是我觉得我小的时候最早接触美国和外国电影的话是 Shirley Temple 系列的小电影。(S2: 还有卓别林的那个)那时候都是中文, 就是看, 黑白的, 然后四中文翻译嘛, 然后可以看到外国人和中国人的不一样吧。但小时候的话记性不是很深, 但是就是知道他们和中国人就是不一样, 能接触到外面的环境吧。就是特别了解, 就是提他舞啊什么的。那个小女孩长的也很漂亮, 黄色的头发, 兰色的眼睛, 然后和中国人特别不一样。然后接下来, Shirley Temple 的电影就不放了, 可能太久了吧。

[...]

S1: 大一点以后看了 Growing Pains。

S2: 哦, 那个我也看国。

Interviewer: 那你们觉得从文化这方面讲如何?

S2: 还不错。还不错。

S1: 他们是将是家庭里面的故事, 两个儿子一个女儿。3 个孩子。讲的是, 可以看到他们父母怎么养育自己的孩子的。他们就是很开放, 让孩子去做自己喜欢做的事情。然后对孩子很支持的。不象

中国父母就是，中国父母在思想上去束缚孩子，他们更有一种朋友之间的感觉。可以互相沟通什么的。即使小孩和父母说说笑笑也不会成为什么问题，更能促进他们的友谊。[...]

Interviewer: 有人看过欲望都市吗?

S1: 我看过。

Interviewer: 那你觉得怎么样? 从文化这个角度讲? 有没有让你觉得对美国中年女人...?

S1: 就觉得他们很开放。就是除了在生活中最重要的对他们来说是爱情。

Interviewer: 最主要就是爱情?

S1: 恩。一个换一个换，不象中国人，最好就是一生就要一个，然后永远就在一起，然后他们就是不适合的就换，不适合的就换，可能今天刚一见面，然后可能发生一些关系，第二天就不认识了，他们在这方面太开放了。

[...]

Interviewer: 那你们觉得 Friends 呢?

S3: [...] 我没什么印象特别深刻的，看完就完了。就是觉得很好玩。

S4: 我感觉，就是破译一下吧，**Friends** 就是我感觉反映了一种美国的那种自己的独立个性，还有家庭观念的那种融合以及碰状。因为一开始都是从学校出来的学生，他没有工作也找不到家庭，然后他们组成的一个临时的团体，但是团体又带有一点准家庭的性质。就这样的话，就是从前对美国了解就是感觉 18 岁后都挺独立的，但是从更深层上反映出那种对家的渴求，以及那种，因为他们也都在社会上忙碌，也都在找自己的工作，自身的一种独立性，对家的渴求，我感觉反映了美国很普遍的社会现象。从中能够看出它的一种社会的问题，或者是那种社会特点。

interviewer: 你说的对家的渴求，能解释以下吗?

他们走到一起，本身就是毫无亲请的一些人，但是最后我感觉他们那种氛围就象家一样的那种感觉。[...] 就是他们在心理上喜欢有家的。

[...]

S4: 我感觉他们整个，从 **Friends** 反映出来的，他们那种从 20 多岁到 30 对这是人生发展很重要的过程，他从那种很青春的，优点青色的到那种成熟，中间要经理那种心理的叛逆，那种生活方式的漂泊，那种对爱情的渴求，对家庭温暖的向往，需要一个，组建一个稳定状态，有工作有家庭，稳定湖脏的的追求，然后整个他们在社交上，恋爱观上，其实都是有很多中隐藏自己心理东西那种碰状的。

Interviewer: 你们几个有没有片子都看过 (S3: 就是 Titanic) 但是觉得文化价值不大的? Titanic 如何?

S3: 我觉得还有啊。

S2: 还好啊。

S4: 还有爱情的。

S3: 知道的东西还挺多的啊。

Interviewer: 为什么呢?

S3: 就是关于生命啊，关于什么我觉得挺多的。

S2: 就是观念嘛，思想上的东西。

S3: 行为都很不一样。

S4: 我感觉...

Interviewer: 你说你感觉怎么的?

S4: 我感觉，在爱情观这个问题，这个 **Forest Gump** 和 **Titanic**, **Waterloo Bridge**, 等等一系列美国电影，反映的都有些不同。因为他这些电影往往反映的都是很闪电式的爱情，然后通过 **Friends** and **Sexy and the City**, 更是那种，虽然意识很强烈，但是持久的很飘忽不定的那种东西。好象给人挺失望的感觉。但是 **Forest Gump** 不一样，他从小到大就和那一个女孩，(interviewer & girls laugh) 他就喜欢那个女孩，到最后那个女孩去世之后他也没喜欢其他人。所以我觉得 **Forest Gump** 是美国爱情观电影里的很特例的东西。**Forrest** 就一直很的，很其而不舍的。

[...]

Interviewer: 既然你们都看过 Titanic, 我就给你们放一个 Titanic 里面的一个小片段。[...] 我给你们放哪个比较好呢?

H. YANG

S1: 结局。

Interviewer: 不是。你们自己选吧 (explains each clip. then every decided to watch Dinner with rose)

Clip One: Titanic – Dining saloon

(after viewing)

Interviewer: 怎么样? 观后感? 谁先说说?

S2: 等级好森严感觉。他们好象就是有富人阶级和一般的世俗阶级。而且那两种阶级有不同的文化一样, 不好融合, 他刚开始装的挺象, 到后来就开始失态了。我就觉得他们英国就是, 可能现在还存在皇室嘛, 就是君主立宪制, 这种比较传统的等级观念还是比较明显。

S1: 我也有她这种想法, 就是等级挺森严的。低层和上层不一样, 上层看不起低层人, 讲话很讽刺那种感觉。然后还有感觉就是, 虽然他们是上层社会嘛, 开这种 party, 但是大家都是一种作为一种, 形式方面的, 你看这些人好象就是很假, 面目表情就是很僵硬, 可能就是因为你是一个上等人, 你就应该和这种人混在一起, 你就应该参加这种 party, 大家都不用心去交流, 就是很假很假, 你看他们的表情那个女的, 一看就是很严肃那种, 然后又看到这种下等人, 更是, 然后。。。

Interviewer: 你们两个还有要补充的吗?

S3: 恩, 差不多。

Interviewer: 你呢?

S4: 我感觉, 他虽然在这种等级观念很强的 party 里, 但是我感觉通过这种 party 更能够反映出 jack 的那种活泼, 或者说稍微有点赖皮的那种性格, 恰恰是这种性格才招至了女主角的好感吧。另外我感觉, 他未婚夫对她的那种爱, 虽然她一直不接受但是我觉得那种爱也是比较深的。就是他们时间相互爱。

Interviewer and the girls: laugh.

Interviewer: 太逗了。

S4: 我觉得, 女主角为什么更看好 Jack.就是等级上的新鲜感。他们之所以被对方吸引, 就是因为他们对对方的生活都很好奇, 能够让他们产生对爱情的萌芽。咱们假设 Titanic 没有沉没, 然后这个女的, 叫什么?

Interviewer: Rose.

S4: 对, 就是她真的和 jack 在一起, 他们的生活会如何? 她会不会在那种比较下等的生活模式里也会感到很厌倦呢? 她会不会感到很不适应呢? 另外就是那个男的, 就是没有追到她的未婚夫, 在沉船后又找了个新的太太, 就是感觉他们的这种东西, 可能还是爆发性比较强一些。

Interviewer: 哦。。。

S1: 我还有一个要补充的。

Interviewer:哦, 你说。

S1: 还有一点。就是看了这个片段就想起来, Jack 后来带着 Rose 去下等仓, 他们一起跳舞, 那他们作为下等人, 虽然他们没有豪华的生活, 但是他们就是很容易的融合在一起, 然后有说有笑的, 而这些上等人就是把自己的心隐藏起来, 即使他们小时候会有那种热情, 想象下等人那样大家一起说说笑笑, 但是生活中都把他们都磨平了。致使他们越老越封闭那种感觉, Jack 在里面, 作为一个下等人的身份上来, 虽然他没有他们那么豪华的外表, 但是他们生活好象更开心一点。其实我觉得该羡慕的是那种生活而不是那种外在的东西。

Interviewer: 那你们觉得这个片段有没有让你对当时的美国或者是英国有些了解? 或者是有没有给你一些印象或是怎么样? 或者是和你们刚才说的一样?

S1:那些就是我们的印象。对他们文化的印象。

S2: 对。

Interviewer: 我给你们放 Friends,好不好? 你们可以选择以下(explains the clips)

[...]

(decided to watch both clips)

Clip Two: Friends – Chandler's date

(after Chandler said: and none of the responsibilities; girls laughed.... after Ross said: of course not Yah, it is. Everyone laughed)

Interviewer: 来说说吧, 有什么感觉?

290

S2: 他说的话很搞笑啊。好开放啊。真的好开放啊。

S1: 他们没什么避讳，想说什么就说什么。

S3: 我觉得中国一帮男的女的住在一起肯定不敢这么说。

S1: 对啊。

S2: 肯定隐藏着，自己跑到屋子里想一想啊。(S3: 对啊!) 要不然找一个知心的朋友说两句 [...]

S4: 其实我觉得这种是，他们这种开放，在说话上没有拘束使他们的关系才能够那么好，才能够象一个家庭那样。

Interviewer: 有的同学啊，他们看完了这个小片段旧说，有的同学觉得对美国人的交往方式觉得他们什么都敢说。那你们觉得呢？

S2: [...] 就是那个什么，开放嘛 (laugh, feeling a bit shy)

Interviewer: 开放？

[...]

S2: 我觉得他们比较本真，也许吧。

本真？

S1: 本性的真实。

Interviewer: 哦！

S2: 也许吧，也许吧。是不是因为美国历史太短了，和我们一般的传统观念不一样。

S1: 我觉得他们可能把爱情和性看成两样东西了。妻子娶来是爱她 (S2 & S3 laughed) 那个的是满足一下身体的需要。(all girls laughed)

Interviewer: 你们有觉得通过这个小片段让你觉得美国男人和中国男人有什么不同吗？

S2: 当然有了。

Interviewer: 怎么不同？

All girls laughed (looked at S4)

Interviewer: 不要考虑他的存在，有什么说什么。

S1: 中国的男人嘛，爱和性是一个概念，都要专一。

S2: 灵与肉的结合，哈哈。

S1: 如果你在那个方面出轨的话就会被看为道德的问题。那就会有人谴责，所谓的偶把桑在后面乱说，对人？

S2: 我刚才说他们本真就是因为这个嘛，也许中国的男人也有这种想法，这个不错不用副责任什么的，但是他们一定不会说的，他们一定会装的很君子那样的。我觉得一般会这样的。哈哈。

Interviewer (looks at S4) 现在该论到你说了(S2 laughs)

S2: 同意还是不同意啊？

S3: 同意还是不同意啊？

Interviewer: 首先谈谈文化这个角度，然后在说说她们说的。

S4: 那我就说实话了。整个反映为人出事，经历的一种变化，他们现在在一起成活，但是他们 30 岁 40 岁还是可以这么说嘛。

(interrupts) **Interviewer:** 这个小片段就能让你看出来这个？

S4: 是啊，看出来。不是中国的事例也有类似的，叫...形容那种很轻狂的生活，其实本身美国男人中国男人不都一样嘛，是吧？(S2:哦，还是赞同。S3:恩，还是赞同)其实也许价值观有区别，社会的道德有区别，但是他的...其实也没多大区别。

[...]

(interviewer explains the background of the clip)

Clip Three: Friends – Pheobe calls London

(while viewing)

Students did not laugh when Pheobe says: "I do, I do, I do". After Rachel said: "you don't know, it's not over until someone says I do."

After Pheobe says:shir. S4 laughs (got the joke)

(after viewing)

Interviewer: 怎么样?

S2: (giggles)

S2: 挺好玩的。

Interviewer: 有什么观后感? 理解啊什么的?

S2: 觉得英国人和美国人思维好象也不一样啊。

Interviewer: 怎么不一样? 说说?

S2: 就是美国人很率性想说什么说什么。英国人就有点比较 (S1: 绅士嘛) 对啊, 较绅士啊, 很多礼仪啊都要注意啊, 你看, 它打电话就说她找谁, 然后马上就说你要问啊, 你要说自己是谁啊, 什么什么的, 就一大堆。

Interviewer: 那这是你原来就知道的还是通过这个片段看出来的? 或者是怎么样?

S2: 以前没注意这两个国家有什么区别。因为对我来说他们都是外国人, 说英语的外国人, 就刚看这个就发现, 当这两个国家的人对话的时候其实也是有差别的, 其实虽然都是移民过去, 以前美国人不是也从英国过去的嘛, 但是好象是演变的都不一样了。

Interviewer: 还有什么要补充的吗?

S1: 我也觉得美国和英国人不一样。美国人可能因为没有太多的历史, 他们就比较现代的东西, 不管什么都比较现代比较随性。不象, 他们可能没有什么束缚, 不象我们, 象我们传统国家的话, 生出来以后就是有很多东西被束缚住了, 都是一些传统的东西, 他们的一些东西就是很现代, 象他们讲的话我想英国也不会这样说吧。

S2: 对对对。

Interviewer: 这是你们两个第一次看这个对吗?

Ss 对, 第一次。

S2: 就看这个吧, 就觉得很开放, 很特别很帅性。

Interviewer: 你们两个呢?

S4: 我感觉, 他们生活方式来讲。美国可能是正三角, 英国是倒三角 (the girls: wow)。英国那可能就是那种重量, 支点的重量比较大, 美国就是比较轻的那种。

Interviewer: 我已经有点晕了, 你是什么意思啊?

S2: 他是不是想说根基的问题啊?

S4: 不是。就是到三角 (draw a picture) 美国处的状态是比较轻松的, 英国可能 (S2: 比较重) 相对担负的东西要重一些。那些社会价构, 压力也比较大一点吧。 (feels as if he wants to impress the girls that he's knowledgable)

Interviewer: 怎么个社会价构压力大?

S4: ...

Interviewer: 还是只是你的一种感觉?

S4: 没有空隙在挖掘了, 因为对这些国家了解也不是很多。

Interviewer: 这个小片段就是让你觉得英国沉重, 美国轻松一些。你是说态度还是精神?

S4: 都有吧。

[...]

Interviewer: 你们看过 School of Rock?

Together: 没有

[...]

Interviewer: 我不是为可考核你。我给你放的是说英语英语字幕 (S2: 还担心啊) 该怎么看怎么看, 你们能理解多少就多少, 我主要就是想知道象你们这样非英语专业, 大学 4 级还没考的学生究竟能看懂多少。明白吗?

S4: 恩。

Interviewer: 不是在考核你啊。就是如果你看完说, 哦, 我就是没看懂, 也不要不好意思。你看我英语专业的, 我大二的时候, 看英文电影也不见得看懂多少。明白吗?

Ss: 恩。

(interviewer explains background of the clip briefly)

S1: 这个剧情我知道。

[...]

Clip Four: School of Rock – Step off

[...]

Interviewer: 你们先告诉我真实感受。看懂多少? 看明白了吗?

S1: 情节什么都看的明白。

S2: 恩。

Interviewer: 哦, 知道怎么回事是吗?

S1: 恩。

Interviewer: 在语言这方面呢?

能不能大概描述一下这个故事发生了什么事情?

S2: 有一些句子的意思不太理解, 就是组合在一起的意思。

S1: 恩。

Interviewer: 那你们能不能说说这个故事发生什么了? 不是在考核你啊, 就是想知道你们的理解。

S3: 就是和他们了解, 就是让他们把想法都表达出来, 把烦恼都抛开吧。就是希望过的, 就是把烦恼都跑开, 好象是。我觉得是那个意思。

Interviewer: 那你们两个和她理解一样吗?

S1: 然后中间有一个情节就是他们用要滚的口气说话, 是吧?

Interviewer: 恩, 你呢? 你的理解是什么?

S4: 感觉师生之间的方式挺开放, 挺活泼的。

S2: 对。

[...]

你们觉得他们的师生关系如何?

S1: 朋友盛过老师。

Interviewer: 那你说在怎么中国呢?

S2: 老师就是老师。不过课堂上老师就是老师, 下了课你可以和他成为朋友, 但是一般在课堂上他们都不会, 就是备好课给你将, 上课提问题, 有的时候还是可以说自己的见解, 但是很多时候都是说一些已经成型的理论什么的。

S4: 我感觉中国的那种师生关系可能就是在当时要更严肃一些, 外国更活泼, 更互动。但是我觉得从长期看, 因为可能受多年从前的思想影响, 中国那种门第观念, 很浓重, 一说谁谁是我的老师, 就象利益集团一样, 但是在外国有没有这种东西我不清楚。可能在外国可能如果上的学历比较高的话, 象你的导师是谁啊, 教授是谁啊, 可以以为自豪的, 但是我觉得在中国好象这种观念, 从小学中学就有这种观念了。你看往往就是毕业多少年后再相距那种, 对老师的那种感情就象自己的长官一样, 就是门第观念特别, 一说出自哪个师们, 就跟武侠小说一样。

interviewer: 你的这些看法都是由这个小片段来的吗? 哪个情节触动你了, 有这种感觉?

S4: 就是感觉他们这种方式, 很开放, 活泼, 所以我就产发了一些联想。

Interviewer: 你觉得很轻松是吗?

S4: 对。

S3: 那个小孩还和老师顶撞。(S2: 对, 小孩都不怕老师的) 小孩什么都敢讲。

Interviewer: 如果给一个百分比的话, 你们自己觉得对这个片段懂了多少?

S2: 是从语言还是情节?

Interviewer: 就是理解, 故事情节。

S3: 一半吧我。

S2: 基本上就那样。

S3: 我觉得我一半就够了。

Interviewer: 你呢? 照实说, 自己是多少就多少。

S1: 情节上 70% 应该有吧。语言的话 (S2: 40%) 一半吧。就是几个单词看不懂, 然后剧情的话, 连续的剧情有点问题。

Interviewer: 你呢?

S4: 就是大体情节基本上能懂。

Interviewer: 你能不能说一下情节是什么?

S4: 一开始台词, 是怎么开始的我忘了。

Interviewer: 我不是让你翻译啊, 你看懂了什么?

S4: 一个学校, 通过摇滚的方式和同学交流, 他先让同学们抒发同学对他的愤怒与不满, 然后就把这个变成了一种乐趣。像 *stet up* (S1 speaks with very little voice: step off) 啊什么的那种。[...] 然后就是让自己抒发真正的那种摇滚的内河吧。

Interviewer: 你们对摇滚乐有了解吗? 喜欢听吗?

S3: 只是挺喜欢听那个节奏。

S4: 我听 Beyond 的那个。很中国化那种。

[...]

Interviewer: 你们听说过撞车这部片子吗?

S1: Crash

S2: 没。

Interviewer: 你们之间都没有人看过?

Ss: 没有。

[...]

Interviewer: 到现在为止你们最喜欢哪个片段?

S1: 老友记。

Interviewer: 老友记 (smiles)

S4: Titanic.

S1: 我觉得是这个 (School of rock)

Interviewer: 为什么呢?

S1: 我喜欢有还是有老师的那种环境。

interviewer: 那其他人呢? 其他人都喜欢哪个?

S4: 我喜欢 Titanic (S3 laughs) 这个比较经典。

Interviewer: 那你呢? 你喜欢哪个?

S3: 我? 老友记。

Interviewer: 那你呢?

S2: 我啊? 谈不上喜欢不喜欢, 都觉得还行。

[...]

Clip 5: Crash –Shop for gun (they all haven't seen it before)

(After viewing first time)

Interviewer: 你们看明白了吗? 说实话。

S3: 我没看明白。

Interviewer: 很多同学的确是看不懂。

S2: 是不是, 它买枪, 然后他们两个说话然后语言不是很通, 然后就吵起来了。

S4: 他...

Interviewer: (stops S4 and lets S1 speaks) 那你呢?

S1: 他们是不是两个阿拉伯人, 然后听不懂, 然后很急的要卖给他们, 又不回他话, 就产生那个了? (S2: 误会) 产生误会了。

Interviewer asks S3: 你呢？

S3: 没看懂。

Interviewer: 为什么呢？是不是因为看不到字幕？

S3: 啊

S2: 基本上看不清楚，很快。

Interviewer: 字幕确实很快。那你们说老板的态度如何？

S2: 不好。

Interviewer: 为什么不好？

S2: 他们两个是黑人吗？

S1: 种族关系吧？

Interviewer: 什么样的种族关系？

S3: 他们两个也是白人啊？

S1: 他们是黄种人好象是。

S2: 他们两个不是白人啊？

S1: 他们两个是阿拉伯人。（S2: 黄种人？）肯定不是美国人

S2: 那就是说是外来异族啊，那可能是种族方面的问题啦。

S1: 美国人就是这个方面比较有特点。

[...]

S4: 我感觉它和这个 911 事件有关。

Interviewer: 那你说说都发生了什么？

S4: 因为他要去买枪，老板听说他是阿拉伯人，就拒绝把枪卖给他们。说他是用 717 飞机去撞他们的楼，说他可能就是，由于 911 时间印发的那种美国民族和阿拉伯民族之间的仇恨，虽然，他们在买枪，其实阿拉伯人也很憎恶卖国对他中东地区一直以来的插手干涉，就是，民族上的矛盾在他们两个人的个体之间发生了很激烈的碰撞。

Interviewer: 那从文化来看，这个小片段有有没有让你对美国有一定的了解？

S4: 一方面老板为什么拒绝买给他，一方面就是 911 带给他们的那种恐慌。阿拉伯世界用飞机去撞他的楼，很暴力很恐怖的情景，使他一方面是惧怕，把枪卖给阿拉伯人，因为对他们同胞的杀戮使他有恐惧心理，震撼，也产生了一种愤怒，所以他拒绝把枪卖给阿拉伯人。他听到他们是阿拉伯人以后也表现了非常愤怒。

Interviewer: 那你觉得有种族歧视在里面？你觉得？

Interviewer: 我感觉和种族其实不大，但是种族之间的矛盾和分歧在里面更大。他是一种仇视状态，他为什么杀他同胞啊，阿拉伯人也在想你为什么老管我们的事情，老杀我们的兄弟啊。

[...]

Interviewer: 你们几个知道 911 吗？

S2: 啊，这个到知道。

Interviewer: 听他说完之后，你们觉得他说的对吗？

S1, S2: 仿佛是有点。

Interviewer: 为什么仿佛是有点呢？

S2: 因为只看了一个开头嘛，而且字幕也没有看清楚，我也看到 747 的飞机，然后我看解放我的国家，没看青那个字幕，我觉得好象也和战争有关系，但是没看清楚。也不知道到底是什么。

Interviewer: 我再给你们放一边，能理解到什么地步就是什么地步。看看有没有更多的发现。

(S3 left to answer phone call)

(After viewing the second time)

Interviewer: 这次如何？

S1: 我觉得好象他可能是因为, 应该是文化的差异吧。因为他一开始, 他们两个在讨论, 然后老板不知道他们买不买, 然后才发生矛盾, 就是因为发生矛盾以后大家心理不开心, 然后老板才会讲关于恐怖时间的事情。

S2: 差不多。

S4: 就是我感觉他一开始可能不知道他是阿拉伯人, 但是一听到他是阿拉伯人才...一开始还想把强卖给他, 说买什么私下讨论, 想卖给他, 后来他们用阿拉伯于讨论, 老板体会来, 所以我就不卖了。

S1: 他刚刚不是, 是那个卖枪的人先印起来的。他一开始可能以为老板就是跟他声音大声一点可能因为他是种族气质, 因为大家都知道美国人种族其实是很严重的, 他们又不是这个国家的人, 然后发现那个老板一下子对他声音很大的话, 就以为种族歧视, 是客人觉得种族歧视然后他们才那个的。

Interviewer: 那你们对种种族歧视方面的事情在美国了解多少?

S1: 大概知道点。以前看到一个报道, 警察把黑人, 黑人也每做什么坏的事情, 当场就把黑皮肤的人给打死了。然后报纸上就报道了

Interviewer: 那这个片段有没有让你对美国种族歧歧视这方面有什么了解, 新的东西还是确实还是什么?

S1: 我觉得美国人自身, 他可能自己不觉得, 但是做为外国人会可能对这个比较在意吧, 就想我也是, 上海人和美国人有点象, 因为上海人, 不是说上海人看不起外地人嘛, 然后象我这种上海人根本不觉得上海人怎么样, 大家都是中国人, 都一样, 但是我来到北京以后, 来北京之前, 我姐姐在北京上大学, 说你到了外地千万别说你是上海人, 要说你就说你是南方人。不然人家会不喜欢。我们宿舍还可以吧, 后来有一次和别人聚餐, 和上海男同学, 他带了一个外地的同学, 他说, 中国一共有两种人, 一个是上海人, 一个是外地人。然后就感觉有点象, 本事自己是没有认识到这个问题, 但是别人会知道这件事情就很敏感。(distinguish)

Interviewer: 你们有同感吗?

S4: 恩。。。

Interviewer: 在她说之前你们有这种感觉吗?

S4: 对中国的歧视到是没什么感觉。

Interviewer: 我是说对 S1 说的阿拉伯人敏感, 你在她说之前有这种感觉吗?

S4: 有一点吧。

Interviewer: 有一点?

S4: 就是她说了之后就更明朗了。一开始我就感觉可能和 911 有关。

Interviewer: 这是你的第一感觉?

S4: 对。

Interviewer: 那她说阿拉伯人敏感, 在你的想法中强烈吗? 还是听她说完后, 觉得, 哦, 确实是这样?

S4: 那她说经过 S2 点化, 我觉得有道理。

Interviewer: 那你觉得呢?

S2: 也觉得她(S1)说了以后就觉得有道理。

[...]

Interviewer: 如果老师通过这种片段的手法来帮助你们了解英语国家的文化这方面, 这种手法你们喜不喜欢? 好不好?

S3: 好。

S2: 好是好。

Interviewer: 你说为什么好?

S3: 我觉得更综合吧, 全面的什么都有了。

Interviewer: 你说的什么都有了, 包括什么?

S3: 听啊说啊, 写啊, 你还能知道他们讲的话, 还有背景啊, 还有剧情啊, 可以很享受的看, 这样很舒服啊, 我觉得, 要是说语言的话, 我觉得最好是跟将那个语言的人交流最好。

Interviewer: 你刚才说好到是好是什么意思?

S2: 我说好到是好, 但是有时候吧上课他就是注重情节了, 但是就不是很注重语言练习了。

Interviewer: 你是说学生是吗?

S2: 对于学生学英语来说。你要是这种电影你看一遍的话一般看的都是故事，第二遍才有可能去注重他的语言，第一边你要是注重的话也是一些非常简单自己听得懂的。哦，这句话我听得懂，然后很高兴。就可以注意一下。

Interviewer: 那你觉得从文化这方面呢？

S2: 文化还是可以的，因为你看情节就会去理解他们那个故事的内涵，故事的内涵我觉得就是有关于背景的吗，背景就是他的文化。

Interviewer: 你还有要补充的吗？

S1: 如果光从文化上面看，我更喜欢记录片，综艺节目，更直接。象你看，电影就是情节，没情节就不是电影了，对吧。但是如果你是记录片的话，有点象，用画面和声音的手段让你不是光看书，听老师讲，了解更多关于这个国家，更详细一点。而且，因为他本身我不能接触到，所以兴趣会更大。 [...]

Interviewer: 你呢？

S4: 如果个人要提高英语这种方式就够了，但是如果比较普遍去学习英语还是要全社会的倡导。

Interviewer: 那文化呢？老师用这种手段？

S4: 用这种手段当然好，因为它是很原太的。但是，我感觉它是不是跟真正的美国社会是贴近的，因为从中国的电影我就能看出来，它往往带有一些艺术化的东西，他是不是真实的美国社会的？美国的真实社会是不是每个人都象 Forrest 那样都能得到社会的爱 (girls giggles) 他又那么的爱社会？是不是就象 Shawshank Re 里面那样每个人受冤枉，然后在监狱里那么黑暗造成那种暴力呢？是不是整个社会的场景都是那样？它仅仅是把其中 (S2: 夸大) 的末个点，经过艺术家的演义，演绎出过就是为了好看，吸引你，能够印发你心理的东西，但是他未必就是真正很平凡很平淡的生活。

Interviewer: 那我们刚才放过的那几个片段如何？

S4: 我感觉他们是经过演绎的。跟美国的原声太的，美国人也并不是每天都在谈恋爱。都在象 Forrest 那样用他笨笨的头脑在思索。他也要吃饭睡觉，都有嘛。

Interviewer: 我是说我们刚才看多的比如说 Friends, Crash, 那几个，如何？

S4: 我感觉他们能够体现一种生活的东西，但是体现的并不是很完全，或者是他体现的比真正生活高那么一点点的东西。他的经过提炼，凝结出来的。

Interviewer: 你说提炼是什么意思？

S4: 因为她拍成电视剧肯定要提炼的，比如说咱们 5 个人在一起说话，然后拍成电视剧了，那不大可能。

Interviewer: 你们觉得我们刚才看国的这几个片段，[...] 从文化这方面来看，有没有价值？你们个人觉得？

S1: 价值就是很小的一部分。

Interviewer: 恩，你说。

S1: 都是商业片吧，纯属娱乐。你看电影就是休闲娱乐放松马，你哪会去深层次的去考虑他的内在联系。除非你特别特别喜欢，重复的看，比如 Titanc, 当时会很触动，但是会有很大的触动，但是大多出都是娱乐方面的。

Interviewer: 那你同意吗？

S2: 比较同意。艺术嘛，就象她说的那种，它不是真实的，他是从生活中截取的某一方面去突出的表现他。就是说你从一个电影里面你可能会体会到一种文化，但是这种文化只是一个片面的东西，就是你不能很深刻的或者全面的去了解它，也可能你从这里学到的，看到的，理解到的，就是偏差了，就是不是很准确。她说的记录片挺好的，如果是记录片可能会更全面更真实一点吧。

Interviewer: [...] 如果老师用这几个片子在英语课堂中的从文化角度来看话有价值吗？

S1: 应该有。

Interviewer: 这是你的真实想法吗？

S1: 是。就象你刚才，看好一段，老师就象你这样提问，让我们去思考，看我们总结出来的东西也不少吧。(everyone giggles) 然后大家，事实摆在面前是有作用的嘛，比课堂上真正懂的肯定要多很多，而且这里面不是光看，就是从自己内心里面感受到的，了解到的，不是象背过的东西。眼前晃晃就没了，看看就没了，这样子肯定会印象深刻吧。

Interviewer: 你呢？

H. YANG

S4: 感觉课堂上利用电影这种性质是非常好的。(girls giggles)

Interviewer: hahah,怎么我又问了一遍大家口气都变了!这是你真实想法吗?

S4: 是啊。确实放电影利用多媒体,利用现代话,就是感觉很好。

Interviewer:你觉得这几个片段文化价值大吗?

S4: 文化价值挺大的。

Interviewer:哈哈,为什么?

S4: 就象刚才放的这几个片子,他确实能够体现。。。从 Friends, 还有 Titanic 还有 School of Rock, 可能从不能的方面层次上,有的可能比较高雅一点,有的可能比较通俗一点,但是他们从不同的方面和层次体现美国社会倡导的,所隐藏的那么一种精神,和矛盾的存在,能体现美国,美国社会的一些片段啊什么的。

Interviewer:你们是不是以为我要用这个去教啊?

S1&2:没有啊。一点都没有。

Interviewer:你们可千万别以为我要用这个叫所以觉得这个肯定好。我觉得我们采访就这样。[...] 多谢你们的合作,实在是太感谢了。

Ss: 没事没事。

Appendix 8: List of Data Analysis Codes

List of codes and sub-codes

Code	Sub-code
Compare: see similarity	Character & self
	Character & dad
	Character & teacher
	Character & Chinese
	American with Chinese
	Western ppl with Chinese
	Group with Chinese
Compare: see difference	Character & self
	Character with parents
	Character with teacher
	Character with Chinese
	Westers (注意用的词) with chinese
Film clip	American Pie_Father Son Chat
	BJ Diary_Couple dinner
	BJ Diary_Prepare for Launch
	Crash_Director
	Titanic_Dining Saloon
	Titanic_Women and children
Films have seen	American Beauty
	American Pie
	BJ Diary
	Brave Heart
	Casablanca
	Coyote Ugly
	Dead Poets Society
	Desperate Housewife
	Devil Wears Prada
	Forrest Gump
	Friends
	Ghost
	Harry Potter
	Legally Blond
	Lion King
	Lost in translation
	Prison Break
	School of Rock
	Sex and the city
	Shrek
	Snow White
South Park	
The Graduate	
The Queen	
The Simpsons	
Titanic	
Interpretation change over time	Watched before
	Watched with friends
	Learned a lot till college (knowledge)

Recontextualize	Character in self place
	Self in fictional context
	Chinese in fictional context
	待定
分不清楚美国英国	Films do not like to see, comedy
Effect on perception	Films does not like to see, female subjects
	Reinforce the existing impression
	shape understanding, view, impression, perception
Titanic	interpretation, characters
	recall scenes
	recontextualize
Make sense	1_Activities after viewing
	1_Apply knowledge to understand
	1_Basic comprehension, wrong
	1_Compare_Identify differences
	1_Decenter, critical
	1_English soundtrack & Chinese subtitle
	1_Hard to distinguish British and American
	1_Identify similarity
	1_Recontextualize
	1_换位思考 Transposition thinking, ability to empathize
	Admire characters
	Apply personal experience
	Compare American TV and Chinese TV
	Compare foreign with China
Compare the characters in the film with Chinese	
Make sense	Critical
	Critical low
	Discuss with friends
	Diversity interpretation, Crash
	Diversity, Forrest gump
	Good actor
	Identify similarity
	MS, Interpretation of the text
	MS, Understanding text
	Perceive as realistic, Mirror reality, close to reality
	Produce meaning based on personal understanding on the story and interpretation
	Recontextualize character in the Chinese context
	Recontextualize the situation in own context
	Relate to Chinese culture that ss are familiar with
Relate to the characters in the film	
Speculate	
Viewing triggered memory of personal experience	
Language indicators	compare
	Re-contextualize
	Film can or cannot help learn UK and USA, students attitudes
	Motivation, purpose, expectation of viewing film
	Parents and Children, typical images
	Sense Making surface comprehension
	Stir feeling deeply
Teachers and students	
Affection to character	
After Viewing	
Before Viewing	

Effects on students' perception of people and culture	Further enhance	
	Further enhance existing impression on American and British, other resources, Friends, Clip Phobee, understands humor,	
	Further enhance existing views	
	Generalize	
	Learn more	
	Mean Girls, American Highschool girls intrigue against each other, similar to Chinese girls	
	Pereception	
	Views on Chinese people's intrinsic quality is not as good as westerners', Titanic, deep impression on Clip Women and Children First,	
	Views on college students love in China, Titanic, heartshaking love	
Factors influence sense making, interpretation	Film review	
	Interests in films	Interests in film, important, low interests, not think about it too much
		Interests in films are important, high interests, keep watching and studying
	Involvement	
	Making distinction between British and American as well as British and American films	Cannot tell whether Shawshank Redemption is British or American film
Hard to distinguish British and American, easy to tell Japanese and Korean		
Students' views on whether films and TV series produced in the UK and USA can help them learn more about these two countries	Film TV series helps learn UK and USA	Crash, learn more about American and USA
		Film, help learn UK and USA, Americans approach
		Films can help learn UK and USA, criteria, recommendations
		Films help learn UK and USA
		Films help learn UK and USA through language
		Films help learn UK and USA, American Pie
		Learn from comparing and differences
		Learn through Chinese films
	Students' talk on films and TV series cannot help learn more about UK and USA	Films are exaggerated, commercialized, intentionally and deliberately, not most original things
		Films are made in cultural context, compare, learn from differences
		Films cannot completely reflect a nation, need carefully chosen
Types of Viewer	Inactive viewer	
	Inspiration Seeker	
	naive	
	Opposite to native	

Motivation, purpose of viewing films	Film help 系统化知识 systematise knowledge
	Film, cultural product, learn by comparison
	Film, enriching self, classic sentences
	Film, enriching self, classic sentences (2)
	Films, enriching self, memorising scenes
	Gain new knowledge
	Likes to watch films very much in peacetime
	Purpose of seeing film, improve English
	Purpose of seeing film, inspiration
	Purpose of seeing film, practice listening skills
	Reason, like to see classic films, enrich self
	Value of film, film as something inspires people
	Students' comments on value of good and bad films in terms of learning
Master piece is much better than bad films	
Students' prior expectation brought to films and TV series	Expectation from films, class films are better than bad ones
	Films are made in cultural context, compare, learn from differences
	Learn most about USA, American Pie, because its so realistic
	Viewing film for the sake of viewing film
触动比较大, 震撼, stir feelings deeply,	
films or TV series which they have deep impression on	Deep impression, Titanic
	Film, Coyote Ugly, deep impression
	Film, deep impression, Coyote Ugly, American Parents, supportive
	Film, deep impression, Coyote Ugly, American young people, enthusiastic
	Film, deep impression, Coyote Ugly, American young people, independent
	Films which give students deep impression
	Films, deep impression Forrest Gump
	Reasons, learn UK and USA, American Pie, 太真实了 incredibly realistic
Typical images	American
	American teacher
	American young people
	Chinese
	Chinese parents
	Chinese teacher
	Chinese young people
	Fictional American parents, relationship with children
	Fictional American teacher
Western parents, with children	
Interpretation on character	
Not sure	
Preferable resources to learn more about UK and USA	films
	Internet
	Language partner
	News
	Teacher
Purposes of learning English and important skills students believe they need to develop	English in films is completely different from English we normally speak
	English that Chinese college students are learning is very formal not useful
	Main purpose of learning English, important skills speaking and listening
Resources for Chinese students to learn more about UK and USA	Film magazine produced in China
	films, English teachers, magazines
	Internet

Pay more attention on learning more on UK and USA on purpose	Resource, English class		
	Resource, films		
	Resource, Magazine		
	Resource, Newspaper		
	Resource, Radio		
	Resource, teacher		
	Resource, textbook,		
	Resource, Games		
Sense_making and interpretation process: Major topics	Parents and Children	American Pie, Clip Father and son, parents communication approach	
		American Pie, Clip Father and son, American sex education, parents attitude and approach,	
		American Pie, Clip Father and Son, parents communication approach, like friends, compare	
		Coyote Ugly, American and Chinese parents and children	
		Coyote Ugly, deep impression on American young people, parents, generalization, think of self	
		Growing Pains, parents and children, cultural differences	
		Princess Diary, grandparents and younger generation of family	
	Teacher and students	Mean Girls, speculate teacher and students relationship in America, compare with China	
		School of Rock, American and Chinese teachers and students,	
		School of Rock, compare American and Chinese teachers, teachers and students relationship, does not admire blindly	
		School of Rock, reminds about Dead Poets Society, teachers approach, compare with Chinese	
		School of Rock, place the teacher in the Chinese context, compare American and Chinese teaching approach	
	Personal interpretation on the clips shown	Andromeda, interpretation, attitude effect, over publicize America (2)	
		Crash, interpretation plays essential role of effect	
Crash, learn more about American and USA, interpretation of name and film			
Interpretation, retell story, own interpretation of scene			
Interpretation, seeing too much from the film, generalization			
Interpretation, using own knowledge in American			
Interpret text, use existing knowledge, stereotype			
Knowledge and interpretation			
realistic	American Pie, Learn more about USA, because its so realistic		
	Realistic things are attractive, complete knowledge system		

Types of reaction after viewing	American Pie, Clip Father and son, recall, think about own experience, sex education
	Associate
	BJ Diary, Launch, Gay phenomenon in UK and China
	Compare
	Coyote Ugly, compare American and Chinese young people, parents
	Crash, Clip Two Policemen, makes him think deeply
	Crash, deep impression, and thik deeply about racial descrimination in USA society
Types of reaction after viewing	Friends, Chandler date, views on sex relationships Americans are open, connect and project self
	Intercuality
	Mean Girls, speculate teacher and students relationship in America, compare with China
	Mean Girls, speculate teacher and students relationship in America, think of similar topic in China
	Place self in others position
Project	Coyote Ugly, Project self in similar situation
	Project, associate, imagine,BJ Diary launch, own view on gay and explanation
	Project, Friends, relationship
Relate	Titanic, heartshaking love, promoted thinking about, trigured, students love in college
Students talked about American Pie	American Pie, Clip father and son, Generalizing,
	American Pie, Clip Father and son,parents communication approach
	American Pie, Virgin Deal
	American Pie,Clip Father and son, American sex educaiton, parents attitude and approach,
	American Pie,Clip Father and Son,parents communication approach,like friends,compare
	American Pie,Clip Stefler Party, film as only resource of info, students tend to believe
	American Pie,film for entertainment, American young people are open, similarity, comparision, generalization
	American Pie.
Students comments Babel	
Ss comments BJ Diary	BJ Diary, Couple dinner
	BJ Diary, Launch
Brave heart	Brave Heart, deep impression on last scene, interpretation,strongly emotionally involved
	Brave Heart, heartshaking, spirit of freedom
	Brave Heart, likes the film, yearn for freedom, deep impression on last scene, cultural admosphere
	Brave Heart, Return Home
	Brave Heart, Wedding
Brokeback mountain	Brokeback Mountain, gays are not accepted in American society
Coyote Ugly	Coyoge Ugly, gives her deep impression
	Coyote Ugly, American and Chinese parents and children
	Coyote Ugly, American young people are open,imagine in China
	Coyote Ugly, compare American and Chinese young people
	Coyote Ugly, deep impression on American young peoples characteristic
	Coyote Ugly,deep impression on American young people, parents, generalization,think of self

Crash	Crash, Change the lock
	Crash, Clip Director shooting film
	Crash, Shop for gun
	Crash, Two policemen
	Crash,Clip Two Blackmen, effect, further enhance existing views
	interpretation plays essential role of effect
	learn more about American and USA, interpretation of name and film
	learn more about racial situation in USA
Dead Poets Society	
Desperate Housewives	
Devil wears Prada	
ET	
Final Destination	
Forrest Gump	Forrest Gump, College day
	Forrest Gump,students talk about FG in general
Friends	admire lifelong friendship
	Chandler date, American are open in sexual relationship, place self in others position
	Chandler date,only resource, use info from other resource
	compare attitudes to relationship, project in Chinese context
	Friends, Chandler's Date
	Friends, Lesbian wedding
	Friends, Rachel doing laundry
	Friends,Clip Phobee, understands humor,further enhance existing impression on American and British, other resources
	more indepth understanding on American middle class
popular, close to life	
Ghost	
Gong with the Wind	Gong with the wind, learn knowledge, decenter, highly critical
Good Will Hunting	
Growing Pains,	impression on American TV series and Chinese TV series, parents and children
Harry Porter	
Kill Bill	Kill Bill, American violence culture
Legally Blond	
Lion King	
Lost in Translation	
Love Actually	
Mean Girls	Mean Girls
	Mean Girls, role of personal experience,does not like the film because personally hate complex human relationships
	Mean Girls, speculate teacher and students relationship in America, compare with China
	Mean Girls, widen her vision on American high school girls
Pirates of Caribbean	
Pride and Prijudice	
Princess Diary	Princess Diary, elder member of the family with younger member of the family relationship
	Princess Diary, unexpected interpretation and reaction
Prison break	Prison Break, reflect American society racial situation, apply own knowledge in interpretation
Pulp fiction	Pulp Fiction,inspiration, philophy of life

School of rock	School of Rock, American and Chinese teachers and students,
	School of Rock, compare American and Chinese teachers, teachers and students relationship, does not admire blindly
	School of Rock, Dead Poets Society, interpretation on teacher, great teaching approach
	School of Rock, reminds about Dead Poets Society, teachers approach, compare with Chinese
	School of Rock, place the teacher in the Chinese context, compare American and Chinese teaching approach
Sex and the City	
Shawshank Redemption	Shawshank Redemption, like it very much, interpretation on film, emotionally involved,
Shirley Temple	
Shrek	
Sleep over	
Snow White	
South Park	
The Graduate	The Graduate, learn more about American and USA, generalization
	The Graduate, similarity, related, compare, connect
The Queen	
The Simpsons	
Titanic	deep impression on Clip Women and Children First, effect on perception
	deep impression on Priest scene, speculate strong religion in foreign countries
	deep impression on strong class characters, status in foreign countries, generalization
	Titanic, Before ship sink
	Titanic, Dinner with Rose
	Titanic, Women and Children first
	Titanic, heartshaking love
永不妥协	
Students' views on the English in films and textbooks and differences between them	Compare language in films with language in textbooks
Teachers use films and TV series in English classes in China	approaches
	satisfaction
Ways of accessing films and TV series produced in the UK and USA	Cinema
	DVD
	Film club
	Internet
	Intranet on campus
	Pirated DVD
Films, like to see	DG Films definitely see, blockbuster, new blockbuster, films with good publicity 大片
	DG Films see, old films, reason_ influence from mom
	Films like to see, has deep thoughts ideas in it, films that inspire my thoughts
	Films like to see, adapted from masterpiece
	Films like to see, Blockbuster
	Films like to see, Braveheart
	Films like to see, class films
	Films like to see, close to daily life, about history, Blockbusters
	Films like to see, Crash
	Films like to see, like the actress
	Films like to see, plot
Films recommended to see, associate with characters	

Films see a lot,	cartoon films
Films see a lot	popular ones
Films sees more	American films, know America better
Films want to watch	Reason, want to see a film, common language with peers
	Reason, want to see a film, everyone talks about it
	Reason, want to see a film, have read the book
不喜欢看的电影	Films do not like to see, Block Blusters
	Films do not like to see, comedy
	Films does not like to see, female subjects

References

- ADELMAN, M. B. & LUSTIG, M. W. 1981. Intercultural communication problems as perceived by Saudi Arabian and American managers *International Journal of Intercultural Relations*, 5, 349-363
- AIEX, N. K. 1988. Using Film, Video, and TV in the Classroom. *ERIC Digest* [Online], 11. Available: http://www.eric.ed.gov/ERICWebPortal/custom/portlets/recordDetails/detailmini.jsp?_nfpb=true&_ERICExtSearch_SearchValue_0=ED300848&ERICExtSearch_SearchType_0=no&accno=ED300848.
- ALASUUTARI, P. 1999. *Rethinking the media audience: the new agenda*, London, Sage.
- ALICIA., M.-F. 2007. Analysing Request Modification Devices in Films: Implications for Pragmatic Learning in Instructed Foreign Language Contexts *In: ALCON SOLER, E., SAFONT, JORDA., & MARIA, PILAR (EDS) (ed.) Intercultural Language Use and Language Learning*. Springer Netherlands.
- ALPTEKIN, C. 2002. Towards Intercultural Communicative Competence. *ELT Journal*, 56, 57-64.
- ANAND, R. & LAHIRI, I. 2009. Developing skills for intercultural competent care. *In: DEARDORFF, D. K. (ed.) The Sage Handbook of Intercultural Competence*. London: Sage.
- ANG, I. 1985. *Watching Dallas*, London, Methuen.
- ARASARATNAM, L. A. 2008. Further testing of a new model of intercultural communication competence. *Annual meeting of the International Communication Association*. New York.
- ARKSEY, H. & KNIGHT, P. 1999. *Interviewing for Social Scientists*, London, Sage.
- BAILEY, K. D. 1994. *Methods of Social Research*, New York, McGraw-Hill.
- BAKER, T. L. 1999. *Doing Social Research (3rd Ed)*. Boston, McGraw-Hill Companies, Inc.
- BALTOVA, I. 1999. Multisensory language teaching in a multidimensional curriculum: The use of authentic bimodal video in core French. *The Canadian Modern Language Review*, 56, 32-48.
- BARAK, S. 2008. China uncensors Wikipedia. *The Inquirer* [Online]. Available: <http://www.theinquirer.net/inquirer/news/1029579/china-uncensors-wikipedia> [Accessed 11 Jan 2011].
- BARAN, S. J. & DAVIS, D. K. 2008. *Mass Communication Theory: Foundations, Ferment, and Future*, Boston, Wadsworth Cengage Learning.
- BARDOVI-HARLIG, K. & BERGSTROM, A. 1996. Acquisition of Tense and Aspect in Second Language and Foreign Language Learning: Learner Narratives in ESL and FFL. *Canadian Modern Language Review*, 52, 308-30.
- BASIT, T. N. 2003. Manual or electronic: the role of coding in qualitative data analysis. *Educational Research*, 45, 143-154.
- BASIT, T. N. 2010. *Conducting Research In Educational Contexts*, London, Continuum International Publishing Group.
- BAUER, R. A. 1964. The obstinate audience. *American Psychologist*, 19, 319-28.
- BAUER, R. A. & BAUER, A. 1960. America, mass society and mass media. *Journal of social issues*, 10, 366.
- BEADLE, M. 2003. The influence of television and media use on Argentines about perceptions of the United States. *In: ELASMAR, M. G. (ed.) The impact of international television: A paradigm shift*. New Jersey: Lawrence Erlbaum Associates.
- BELZ, J. A. 2007. The development of intercultural communicative competence in telecollaborative partnerships. *In: O'DOWD, R. (ed.) Online intercultural exchange: An introduction for foreign language teachers*. Clevedon, UK: Multilingual Matters.
- BENNETT, M. J. 1986. A developmental approach to training for intercultural sensitivity. *International Journal of Intercultural Relations*, 10, 179-196.
- BERELSON, B. 1959. The state of communication research. *Public Opinion Quarterly*, 23, 16.

- BERREMAN, G., D. 2004. Ethnography: method and product. In: (ED.), V. K. S. (ed.) *Methodology and Fieldwork*. New Delhi, India: Oxford University Press.
- BERRY, J. W., KIM, U., POWER, A., YOUNG, M. & BUKAKI, M. 1989. Acculturation in plural societies. *Applied Psychology: An International Review*, 38, 185-206.
- BILTEREYST, D. 1991. Resisting American Hegemony: A Comparative Analysis of the Reception of Domestic and US Fiction. *European Journal of Communication*, 6, 469-497.
- BIMROSE, J. & BAYNE, R. 1995. A multicultural framework in counsellor training: a preliminary evaluation. *British Journal of Guidance and Counselling*, 23, 259-265.
- BIRDS, S. A. & WILLIAMS, J. N. 2002. The effect of bimodal input on implicit and explicit memory: An investigation into the benefits of within language subtitling. *Applied Psycholinguistics* [Online]. Available: <http://people.pwf.cam.ac.uk/jnw12/subtitling.pdf>.
- BO, Y. 2006a. 英文影视片练就地道英语——影视片的妙用 Mastering native English by using English language films - Ways of using English films. *电影评介 Movie Review*, 24, 87-88.
- BO, Y. 2006b. 影视片的英语视听教学之方法和途径 Ways of Video-based Listening Teaching. *宜春学院学报 Journal of Yichun University*, 5, 134-136.
- BOGDAN, R. G. & BIKLEN, S. K. 1992. *Qualitative Research for Education* In Boston, MA, Allyn & Bacon.
- BORDWELL, C. 1969. *The Film and the ESL Program: To View or Not to View*. Chilton Books, 401 Walnut Street, Philadelphia, Pa. 19106 (\$4.00 single issue).
- BORRAS, I. & LAFAYETTE, G. 1994. Effects of multimedia courseware subtitling on the speaking performance of college students of French. *The Modern Language Journal*, 78, 66-75.
- BOUMAN, L. 1996. Video, An Extra Dimension to the Study of Literature. *Language Learning Journal*, 13, 29-31.
- BRADDOCK, R. 1958. An extension of the "Lasswell Formula". *Journal of Communication*, 8, 88-93.
- BREIN, M. & DAVID, K. H. 1971. Intercultural communication and the adjustment of the Sojourner. *Psychological Bulletin*, 76, 215-230
- BRITISH COUNCIL 1974. *Recorded Materials for Teaching English: Information Guide No. 3*. English Teaching Information Centre, The British Council, 10 Spring Gardens, London SW1A 2BN, England (free of charge): British Council, London (England). English-Teaching Information Centre.
- BRUMFIT, C. J. 1990. *Video Applications in English Language Teaching* Pergamon Press/British Council.
- BRYANT, J. & OLIVER, M. B. 2008. *Media effects: advances in theory and research (3rd Ed)*, New York, Routledge.
- BRYMAN, A. 2004. *Social Research Methods*, Oxford: Oxford University Press.
- BUCKINGHAM, D. 1996. *Moving images: understanding children's emotional responses to television*, Manchester, Manchester University Press.
- BUCKINGHAM, D. 2003. *Media education : literacy, learning and contemporary culture / David Buckingham.*, Cambridge, Polity.
- BYRAM, M. 1995. Acquiring intercultural competence: A review of learning theories. In: SERCU., L. (ed.) *Intercultural competence: A challenge for language teachers and trainers in Europe*. Aalborg University Press.
- BYRAM, M. 1997. *Teaching and Assessing Intercultural Communication Competence*, New York, Multilingual Matters.
- BYRAM, M. 2004. *Routledge Encyclopedia of Language Teaching and Learning*, London, New York, Routledge.
- BYRAM, M. 2009. The intercultural speaker and the pedagogy of foreign language education. In: DEARDORFF, D. K. (ed.) *The Sage Handbook of Intercultural Competence*. London: Sage.
- BYRAM, M., GRIBKOVA, E. & STARKEY, H. 2002. Developing the intercultural dimension in language teaching: a practical introduction for teachers. *Modern languages* [Online].
- BYRAM, M., NICHOLS, A. & STEVENS, D. 2001. *Developing intercultural competence in practice*, Clevedon, UK, Multilingual Matters.

- BYRAM, M. & ZARATE, G. 1994. *Definitions, objectives and assessment of socio-cultural competence* Strasbourg, France, Council of Europe.
- CANALE, M. 1983. From communicative competence to communicative language pedagogy. In: J, R., & R, SCHMIDT (ed.) *Language and communication*. London: Longman.
- CANALE, M. & SWAIN, M. 1980. Theoretical base of communicative approaches to second language teaching and testing. *Applied Linguistics*, 1, 1-41.
- CHAFFEE, S. H. & ROSER, C. 1986. Involvement and the consistency of knowledge, attitudes and behavior. *Communication Research*, 3, 373-99.
- CHAPPLE, L. & CURTIS, A. 2000. Content-based Instruction in Hong Kong: Student Responses to Film. *System*, 28, 419-33.
- CHEN, G. M. & AN, R. 2009. A Chinese Model of Intercultural Leadership Competence. In: DEARDORFF, D. K. (ed.) *The SAGE Handbook of Intercultural Competence*. London, U.K.: Sage.
- CHEN, L. 2007a. 大学英语电影口语模仿存在的问题及对策 Imitation of English from films in College English classroom: problems and solutions. *教育与职业 Education and Vocation*, 03, 134-135.
- CHEN, L. 2007b. 观看英文原声电影与英美文化导入 Enjoying original English language movies and inputting English culture. *信阳农业高等专科学校学报 Journal of Xinyang Agricultural College* 02, 144-146.
- CHEN, R. 2009a. 英文电影与英语学习 English language films and English studies. *科技信息 Science & Technology Information*, 04, 418.
- CHEN, Y. 2009b. 认知同化论和利用英文电影进行教学 Assimilation of knowledge and using films for English language teaching. *大众科技 Popular Science & Technology*, 04, 150-151.
- CHEN, Y. 2010. 原版电影与英语教学 Original English language films and English language teaching. *长春理工大学学报(高教版) Journal of Changchun University of Science and Technology(Higher Education Edition)*, 1, 122-123.
- CHEN, Z. & HU, Y. 2011. 1978 年从盗版信号看世界 1978, watching the world through pirated signal. *Wangyi News* [Online]. Available: <http://news.163.com/special/00014DRO/worldcup78.html> [Accessed 11 Jan 2010].
- CHI, H. 2009. 看美剧,学英语 Watching American TV series, Learning English. *英语自学 Teach Yourself English*, 03, 37-38.
- CHINA RESEARCH AND EDUCATION NETWORK. 2001. Evolution of Internet in China. *China research and education network* [Online]. Available: http://www.edu.cn/introduction_1378/20060323/t20060323_4285.shtml [Accessed 12 Jan 2011].
- CHINADETAIL. 2011. *National College Entrance Examination* [Online]. Available: <http://www.chinadetail.com/History/EducationDevelopmentNationalCollegeEntranceExamination.php> [Accessed 11 Jan 2011].
- CHINESE NATIONAL COMMISSION FOR UNESCO & CHINESE ADULT EDUCATION ASSOCIATION 2008. Adult education and learning in China: development and present learning situation.
- CHINESETAPES. 2011. *The Twin Bracelets DVD* [Online]. Available: http://www.chinesetapes.com/movie_chinese/twin_bracelets.html [Accessed 16 Jan 2011].
- CHOMSKY, N. 1965. *Aspects of the theory of syntax*, London, M.I.T. Press.
- CIA. 2011. *China* [Online]. CIA. Available: <https://www.cia.gov/library/publications/the-world-factbook/geos/ch.html> [Accessed 10 Jan 2011].
- CLEVELAND, H., MANGONE, G. J. & ADAMS, J. C. 1960. *The overseas Americans*, New York, McGraw-Hill.
- CNN. 2009. Youtube blocked in China. Available: <http://edition.cnn.com/2009/TECH/ptech/03/25/youtube.china/> [Accessed 11 Jan 2011].
- COHEN, L. & HOLLIDAY, M. 1996. *Practical Statistics for Students*, London, Paul Chapman.

- COHEN, L., MANION, LAWRENCE., & MORRISON, KEITH 2007. *Research methods in education / Louis Cohen, Lawrence Manion and Keith Morrison*, London ; New York :, Routledge.
- COLWELL, H. 2006. Using Films with Mixed Level ESL Classes. *19th Annual EA Education Conference*.
- COMSTOCK, G., CHAFFEE, S., KATZMAN, N., MCCOMBS, M. & ROBERTS, D. 1978. *Television and Human Behavior*, New York, Columbia University Press.
- CONLON, S. H. 1991. Witness: The Movie. A Material Development Project. 1991-03-01.
- CONSTITUTION OF THE PEOPLE'S REPUBLIC OF CHINA. 2004. Constitution of the People's Republic of China. Available: http://www.npc.gov.cn/englishnpc/Constitution/node_2825.htm [Accessed 17 Jan 2010].
- CORBETT, J. 2003. *An intercultural approach to English language teaching* Clevedon, Multilingual Matters.
- CUI, J. 2006. 英美电影——英语语言文化的有效导入途径 British and American films - effect ways of introducing English language and culture. *电影评介 Movie Review*, 16, 67-68.
- DE VAUS, D. 2002. *Surveys in Social Research (5th edition)*, London: Routledge.
- DEARDORFF, D. K. 2006. Identification and assessment of intercultural competence as a student outcome of internationalization. *Journal of Studies in Intercultural Education*, 10, 241-266.
- DENZIN, N. K. & LINCOLN, Y. S. 1994. *Handbook of qualitative research* Thousand Oaks ; London Sage.
- DEVIN, Z. 2007. Dame Judi Dench Discusses Changes In Casino Royale For China. *Casino Royal Official Website* [Online]. Available: <http://commanderbond.net/4067/dame-judi-dench-discusses-changes-in-casino-royale-for-china.html> [Accessed 11 Jan 2011].
- DOCLE, C. 1973. Multicultural education - some issues. *Journal of Teaching Education*, 24, 282-283.
- DONLEY, K. M. 2000. Film for Fluency. *Forum v38*.
- DOOLEY, D. 2001. *Social Research Methods*, Englewood Cliffs, NJ, Prentice Hall.
- DOU, X. & WANG, Y. 2001. 谈如何提高英文电影欣赏课的教学效果 Discussion on how to improve the effectiveness of English Film appreciation lessons. *辽宁广播电视大学学报 Liaoning Radio and TV University Journal*, 4, 55.
- DURHAM UNIVERSITY 2004. *Department Code of Practice on Research Ethics*, Durham University, School of Education.
- EKACHAI, D., HINCHCLIFF-PELIAS, MARY., & KOMOLESVIN, ROSECHONGPORN. 1999. Where are those tall buildings. In: KAMALIPOUR, Y. R. (ed.) *Images of the U.S. around the world: a multicultural perspective* Suny Press.
- ELASMAR, M. G. 2003. *The impact of international television: a paradigm shift*, Lawrence Erlbaum Associates, Inc
- ELASMAR, M. G. & HUNTER, J. 1993. The impact of foreign TV on a domestic audience: A meta-analysis. *Communication Yearbook*, 20, 47-69.
- ELIHU, L. & GREENWOOD, C. 1999. *International Law Reports Volume 114 of International Law Reports Set Complete set*, Cambridge University Press.
- ESRC. 2005. *Research Ethics Framework* [Online]. Swidon: Economic and Social Research Council. Available: http://www.esrcsocietytoday.ac.uk/ESRCInfoCentre/Images/ESRC_Re_Ethics_Frame_tcm6-11291.pdf [Accessed 14 Aug 2010].
- FAERCH, C. H. & PHILLIPSON, R. 1984. *Learner language and language learning*, Clevedon, Avon, Multilingual Matters.
- FANG, W. & LI, N. 2008. 基于原版电影的大学英语教学 Teaching College English based on Original English language films. *电影文学 Movie Literature*, 10, 135.
- FANTINI, A. E. 1995. Introduction-Language, culture, and world view: Exploring the nexus. *International Journal of Intercultural Relations*, 19, 143-153.
- FIEDLERA, F. E., MITCHELL, T. & TRIANDIS, H. C. 1971. The culture assimilator: An approach to cross-cultural training *Journal of Applied Psychology*, 55, 95-102
- FLUITT-DUPUY, J. 2001. Teaching Argumentative Writing through Film. *TESOL Journal*, 10, 10-15.

- FONG, R. 2009. Culturally competence practice in social work. In: DEARDORFF, D. K. (ed.) *The Sage Handbook of Intercultural Competence* London: Sage.
- FRIEDMAN, S. L. 2008. Watching Twin Bracelets in China: The Role of Spectatorship and Identification in an Ethnographic Analysis of Film Reception. *Cultural Anthropology*, 21, 603-632.
- GALLOIS, C., FRANKLYN-STOKES, A., GILES, H. & COUPLAND, N. 1988. Communication accommodation in intercultural encounters. In: LIM, Y. Y. (ed.) *Theories in intercultural communication*. Newbury Park, CA: Sage.
- GAMA, E. M. P. & PEDERSEN, P. 1977. Readjustment problems of Brazilian returnees from graduate studies in the United States *International Journal of Intercultural Relations* 1, 46-59.
- GAO, Y. 2008. 浅析英语电影在英语教学中的应用 Analyzing using English language films in English language teaching. *科技信息 Science & Technology Information*, 26, 255-256.
- GARDNER, G. 1962. Cross-cultural communication. *Journal of Social Psychology*, 58, 241-256.
- GERAGHTY, C. 1991. *Women and soap opera: a study of prime time soaps* Cambridge, Polity Press.
- GEX, J. C. 1982. Films in the ESL Classroom. 1982-00-00.
- GILBERT, R. A. 1993. From Writing to Media with Literature in EFL. 1993-00-00.
- GLASER, B. G. & STRAUSS, A. L. 1967. *The Discovery of Grounded Theory*, Chicago, IL, Aldane.
- GLGE, S. 2008. Using feature films in language classes *Educational Studies*, 34, 1-9.
- GOLDING, P. 1981. The missing dimensions: news media and the management of change. In: KATZ, E. & SZECSEK, T. (eds.) *Mass media and social change*. London: Sage.
- GOLDMAN, M. E. 1993. Using Captioned TV for Teaching Reading. ERIC. Phi Delta Kappa, P.O. Box 789, Bloomington, IN 47402-0789
- GONZÁLEZ, E. M. G. Y. & LINCOLN, Y. S. 2006. Decolonizing Qualitative Research: Non-traditional Reporting Forms in the Academy. *Forum Qualitative Social Research* [Online], 7. Available: <http://www.qualitative-research.net/index.php/fqs/article/viewArticle/162/359> [Accessed 05 Nov 2009].
- GORARD, S. 2003. *Quantitative Methods in Social Science*, London, Continuum.
- GRANDIN, J. M. & HEDDERICH., H. 2009. Global competence for engineers. In: DEARDORFF, D. K. (ed.) *The Sage Handbook of Intercultural Competence*. London: Sage.
- GRIFFIN, K. & SHERRIFFS, E. 1994. Teaching Values through American Movies. ERIC [Online]. Available: http://eric.ed.gov/ERICWebPortal/search/detailmini.jsp?_nfpb=true&_ERICExtSearch_SearchValue_0=ED373543&ERICExtSearch_SearchType_0=no&accno=ED373543 [Accessed 24 Dec 2010].
- GRIFFITH, D. A. & HARVEY, M. G. 2001. An intercultural communication model for use in global interorganizational networks. *Journal of International Marketing*, 9, 87-103.
- GRONLUND, N. 1981. *Measurement and Evaluation in Teaching*, New York, Collier-Macmillan.
- GUDIKUNST, W. B. & KIM, Y. Y. 2003. *Communicating with strangers*, London McGraw-Hill.
- GULLAHORN, J. R. & GULLAHORN, J. E. 1962. An extension of the U-curve hypothesis. *Journal of Social Issues*, 3, 33-47.
- HALL, S. 1980. Encoding, decoding in the television discourse. In: HALL, S., HOBSON, D. & LOWE, P. (eds.) *Culture, media, language*. London: Hutchinson.
- HAMMER, M. R. 1987. Behavioural dimensions of intercultural effectiveness: A replication and extension. *International Journal of Intercultural Relations*, 11, 65-88.
- HAMMER, M. R., WISEMAN, R. L., RASMUSSEN, J. L. & BRUSHKE, J. C. 1998. A test of anxiety/uncertainty management theory: The intercultural adaptation context. *Communication Quarterly*, 46, 309-326.
- HAN, H. P. 1994. *Implementing the video-based instruction in the college-level ESL classroom based on second language acquisition and communicative competence theories*. PhD, North Carolina State University.
- HARRIS, D. P. 1983. The Organizational Patterns of Adult ESL Student Narratives: Report of a Pilot Study. 1983-03-00.

- HAWKINS, R. & PINGREE, S. 1980. Some process in the cultivation effect. *Communication Research*, 7, 193-266.
- HIEBERT, R. E. & GIBBONS, S. J. 1999. *Exploring mass media for a changing world*, London, Lawrence Erlbaum Associates.
- HILL, B. 1999. *Video in language learning*, London, CiLT.
- HOLDEN, W. R. 2000. Making the Most of Movies: Keeping Film Response Journals. Classroom Ideas. 2000-04-00.
- HOVLAND, C. I., LUMSDAINE, A. A. & SHEFFIELD, F. D. 1949. *Experiments in mass communication*, Princeton, NJ, Princeton University Press.
- HOWARD, H. M. F., RICHARDSON, B. K. & SHUFORD, B. 1998. Promoting multicultural education: A holistic approach. *College Student Affairs Journal*, 18, 5-17.
- HUANG, J. 2009. 英文电影在大学英语听说教学中的应用 The use of English language films in teaching College English speaking and listening. *安阳工学院学报 Journal of Anyang Institute of Technology*, 99-101.
- HUANG, Y. & LIU, C. 2009. 英文电影对学生学习英语兴趣培养的作用 Using English language films to improve students' motivation in learning English. *新疆职业大学学报 Journal of Xinjiang Vocational University*, 03, 59-60.
- HUNTER, B., WHITE, G. P. & GODBEY, G. C. 2006. What does it mean to be globally competent? *Journal of Studies in Intercultural Education*, 10, 267-285.
- HYMES, D. H. 1972. Introduction In: CAZDEN, C. B., JOHN-STEINER, V., JOHN, V. P. & HYMES, D. H. (eds.) *Functions of Language in the Classroom*. New York: Teachers College Press.
- IMAHORI, T. T. & LANIGAN, M. L. 1989. Relational model of intercultural communication competence. *Intercultural Communication Competence*, 13, 269-289.
- IMDB. 2006-2011. *Internet Movie Database* [Online]. Available: <http://www.imdb.com/> [Accessed 2006-2011].
- JANDT, F. E. 2004. *An introduction to intercultural communication: Identities in a global community*, Los Angeles Sage.
- JENSEN, K. M. & ROSENGREN, K. E. 1990. Five traditions in search of the audience. *European Journal of Communication*, 5, 207-238.
- JIA, G. 2004. Censorship in China. *UCLA* [Online]. Available: <http://www.international.ucla.edu/article.asp?parentid=18567> [Accessed 11 Jan 2011].
- JIA, Y. 1997. *跨文化交际学 Cross-cultural studies*, Shanghai, PRC, 上海外语教育出版社 Shanghai Foreign Language Press.
- JIANG, Y. 2004. Investing in China's Internet industry: opportunities and competition. *People's daily online* [Online]. Available: http://english.people.com.cn/200502/27/eng20050227_174879.html [Accessed 12 Jan 2011].
- JIANG, Y. 2009. 电影,英语“主题教学”的延伸 Beyond films and English language teaching. *电影文学 Movie Literature*, 02, 127-128.
- JIAO, H. & GAO, P. 2009. 英文电影赏析在英语语境创设过程中的作用 Creating English speaking environment: the role of English language film appreciation. *科技信息 Science & Technology Information*, 18, 736.
- JOHNSON, K. 1981. Some background, some key terms and some definitions. In: JOHNSON, K. & MORROW, K. (eds.) *Communication in the classroom: applications and methods for a communicative approach*. New York: Longman.
- JOKINEN, T. 2005. Global leadership competencies: A review and discussion. *Journal of Eurioean Industrail Training*, 29, 199-216.
- JONES, C. & JOLLIFFE, G. 2006. *The guerilla film makers handbook* Continuum International Publishing Group Ltd.
- KANG, J. & MORTAN, M. 1988. Culture clash: Impact of U.S. television in Korea. *Journalism Quarterly*, 65, 431-438.

- KANG, N. 2008. 英文原版电影对英语口语的提高作用 The effect of English original film to promote Oral English. *湖北广播电视大学学报 Journal of Hubei Radio & Television University*, 11, 135-136.
- KASPER, L. F. 2000. The Imagery of Rhetoric: Film and Academic Writing in the Discipline-based ESL Course. *Teaching English in the Two-Year College*, 28, 52-59.
- KATCHEN, J. E. 1998. Who Dunit? Language Activities for Mystery Movies. 1998-00-00.
- KATZ, E., ADONI, H. & PARNES, P. 1977. Remembering the news: what the picture adds to the sound. *Journalism Quarterly*, 54, 231-9.
- KAYE, N. & MATSON, D. 2000. Swiss Learners of English: Engaging the Advanced Students. *ESL Magazine*, 3, 26-27.
- KERLINGER, F. N. 1970. *Foundations of Behavioral Research*, New York, Holt, Rinehart & Winston.
- KIM, Y. Y. 1988. *Communication and cross-cultural adaptation: An integrative theory*, Philadelphia, Multilingual Matters.
- KING, J. Using DVD feature films in the EFL classroom. *Computer Assisted Language Learning*. 15, 5.
- KING, P. M. & MAGOLDA, M. B. B. 2005. A developmental model of intercultural maturity. *Journal of College Student Development*, 46, 571-192.
- KIRK, D. 1992. Comparison of students' responses to sources of motivation. *The Language Teacher*, 6, 23-25.
- KITAO, K. 1985. A Brief History of the Study of Intercultural Communication in the United States. ERIC [Online]. Available: http://eric.ed.gov/ERICWebPortal/search/detailmini.jsp?_nfpb=true&_ERICExtSearch_SearchValue_0=ED278212&ERICExtSearch_SearchType_0=no&accno=ED278212 [Accessed 28 May 2010].
- KLAPPER, J. 1960. *The effects of mass communication*, New York, Free Press.
- KOLKER, R. 2009. *Media Studies: An Introduction*, West Sussex, Balckwell.
- KOOLSTRA, K. M. & BEENTJES, W. J. 1999. Children's vocabulary acquisition in a foreign language through watching subtitled television programs at home *Educational Technology Research and Development*, 47, 51-60.
- KRAMSCH, C. 1995. The cultural component of language teaching. *Language, culture and curriculum*, 8, 83-92.
- KRAMSCH, C. 1998. The privilege of the non-native speaker. *Plenary address at the Annual TESOL The privilege of the non-native speaker*. Conention, Long Beachm California.
- KRUGMAN, H. E. 1965. The impct of television advertising: learning without involvement. *Public Opinion Quarterly*, 29, 349-56.
- KUPPENS, A. H. 2010. Incidental foreign language acquisition from media exposure. *Learning, Media and Technology*, 35, 65 - 85
- KUSUMARASDYATI. 2005. Subtitled movie DVDs in foreign language learning KUS06105. Available: <http://www.aare.edu.au/06pap/kus06105.pdf>.
- KVALE, S. 1996. *Interviews*, London, Sage.
- LAN, Y. 2009. 英文原版电影在大学英语教学中的有效运用 Using original English language films effectively in College English language teaching. *考试周刊 Exam Weekly*, 10, 99-100.
- LANDIS, D. 1977. Racisms in american education: A model for change : W.E. SEDLACEK and G.C. BROOKS *International Journal of Intercultural Relations*, 1, 122-123.
- LARISCY, R. A. W. & TINKHAM, S. F. 1999. The sleeper effect and political advertising. *Journal of Advertising*, 28, 13-30
- LASSWELL, H. D. 1948. The structure and function of communication in society. In: BRYSON (ed.) *The communication of ideas*. New York: Harper and Brothers.
- LI, J. 2009. 英文电影赏析在大学英语教学中的应用 College English language teaching: the role of English language film appreciation. *电影评介 Movie Review*, 03, 66.
- LI, W. 2010. 用电影辅助英语文学教学的模式探讨 Assisting English literature teaching: exploaring ways of using films. *考试周刊 Exam Weekly*, 01, 95-96.

- LI, Y. 2003. 英语电影欣赏教学新探 English language film appreciation in English language teaching: an exploration. *四川外语学院学报 Journal of Sichuan International Studies University*, 2, 148-150.
- LIAO, X. 2008. 寓教于乐:正确看待原版电影对于大学英语学习的推动作用 Edutainment: a correct view of the value of original English films for learning College English. *辽宁行政学院学报 Journal of Liaoning Administration College*, 07, 160-161.
- LIEBES, T. & KATZ, E. 1986. Patterns of involvement in television fiction: a comparative analysis. *European Journal of Communication*, 2, 151-72.
- LIN, L. 2000a. Manipulating DVD Technology To Empower Your Teaching. 2000-11-00.
- LIN, L. 2000b. Motivational and Effective Film Activities for the Language Lab Class. 2000-05-00.
- LIN, L. 2001. Learner-Centered Activities from the DVD-Format "Crouching Tiger, Hidden Dragon." 2001-11-00.
- LIN, L. 2002a. The Effects of Feature Films upon Learners' Motivation, Listening and Speaking Skills: The Learner-Centered Approach. 2002-08-00.
- LIN, L. 2002b. Learner-Centered Activities from the DVD-Format "Crouching Tiger, Hidden Dragon." 2001-11-00.
- LIN, L. 2008. *English language teaching in present day in China* [Online]. Asia-Pasific Cultural Centre for UNESCO. Available: <http://www.accu.or.jp/appreb/09/pdf33-2/33-2P008-009.pdf> [Accessed 11 Jan 2011].
- LIN, L. 2009. Video Segment comprehension strategies: Male and female university students. *ELT*, 2, 129-139.
- LIU, C., YANG, J. & ZHANG, W. 2009. 利用英语电影教学,提高跨文化交流能力 Using English language films for English language teaching: Improving intercultural communicative competence *科技促进发展 Science & Technology for Development*, 05, 279.
- LIU, J. 2005. 英语影视课教学探讨 Discussion on Teaching with English language films. *太原城市职业技术学院学报 Journal of Taiyuan Urban Vocational College*, 6, 125-126.
- LIU, X. 2006. 中国电视发展关键词: 黑白, 彩色, 数字 The key phrases of development of TV in China. *Xinhua Net* [Online]. Available: http://news.xinhuanet.com/tech/2006-11/20/content_5353218.htm [Accessed 11 Jan 2011].
- LIVINGSTONE, S. M. 1990. Interpreting a Television Narrative: How Different Viewers See a Story. *Journal of Communication*, 40, 72085.
- LIVINGSTONE, S. M. 1993. The Rise and Fall of Audience Research: An Old Story With a New Ending. *Journal of Communication*, 43, 5-12.
- LIVINGSTONE, S. M. 1998. *Making sense of television: The psychology of audience interpretation (2nd Ed)*, London, Routledge.
- LONG, Q. 2003. 电影与英语听说教学 Films and teaching English listening and speaking. *外语电化教学 Media in Foreign Language Instruction*, 3, 48-51.
- LU, X. 2009. 简析英文电影在大学英语教学中的运用 Assisting College English Teaching with English language films. *黄石理工学院学报(人文社会科学版) Journal of Huangshi Institute of Technology(Humanities and Social Sciences)*, 04, 84-86.
- MA, Q. 2009. 英文电影对大学生跨文化交际能力培养的促进作用 Improving College students' intercultural communicative competence through English language films. *电影文学 Movie Literature*, 05, 1309-140.
- MACDONALD, G. & MACDONALD, A. 1991. Variations on a Theme: Film and ESL. 1991-03-28.
- MALAMUTH, N. M. & CHECK, J. V. P. 1981. The effects of mass media exposure on acceptance of violence against women: A field experiment. *Journal of Research in Personality*, 15, 436-446
- MARKHAM, P. 1999. Captioned videotapes and second language listening word recognition. *Foreign Language Annals*, 32, 321-328.
- MARKHAM, P. 2008. Captioned Videotapes and Second-Language Listening Word Recognition. *Foreign Language Annals*, 32, 321 - 328.

- MARTIN, J. N. 1987. The relationship between student sojourner perceptions of intercultural competencies and previous sojourn experience. *International Journal of Intercultural Relations*, 11, 337-355
- MARTIN, J. N. 1989. Intercultural communication competence (special issue). *International Journal of Intercultural Relations*, 13.
- MASON, J. 2002. *Qualitative researching (2nd Ed)*, London, SAGE.
- MAY, T. 2001. *Social Research: Issues, Methods and Process (third edition)*, Maidenhead, Open University Press.
- MCDONOUGH, J. & SHAW, C. 2003. *Materials and Methods in ELT: A Teacher's Guide (2nd Ed)*, Oxford, Blackwell.
- MCGUIRE, W. J. 1973. Persuasion, resistance, and attitude change. In: SOLA, P. I. D. (ed.) *Handbook of Communication*. Chicago: Rand McNalli.
- MCINTYRE, B. T. 2003. Western Mass Media Exposure and Chinese Cultural Values: The Case of Hong Kong. *Paper was presented at Second Hawaii International Conference on Social Sciences*. Hawaii, USA.
- MCMILLIAN, J. H. & SCHUMACHER, S. 1997. *Research in Education: A Conceptual Introduction*, New York, Longman.
- MCQUAIL, D. 2005. *McQuail's Mass Communication Theory (5th)*, London, Sage.
- MCQUAIL, D. & WINDAHL, S. 1993. *Communication Models: for the study of mass communication*, Longman.
- MENG, J. 2009. 英文电影与大学英语教学 English language films and College English teaching. *长治学院学报 Journal of Changzhi University*, 01, 73-75.
- MINISTRY OF EDUCATION. 2005. 《大学英语四六级考试改革方案(试行)》 *College English Test Band 4 and Band 6 Reform Plan* [Online]. Ministry of Education. Available: <http://www.eol.cn/article/20050325/3132232.shtml> [Accessed 11 Jan 2011].
- MINISTRY OF EDUCATION 2001. 教育部关于积极推进小学开设英语课程的指导意见 The suggestions on actively encouraging offering English lessons in primary schools from Ministry of Education.
- MISHLER, E. G. 1986. *Research Interviewing: Context and Narrative*. , Cambridge, MA, Harvard University Press.
- MOLLICA, A. 1978. The Film Advertisement: A Source for Language Activities.
- MORAN, R. T., YOUNGDAHL, W. E. & MORAN, S. V. 2009. Leading global projects: Bridging the cultural and functional divide. In: DEARDORFF, D. K. (ed.) *The Sage Handbook of Intercultural Competence*. London: Sage.
- MORGAN, C. 2005. *Cultural Validity. Personal Communication*, University of Bath, Department of Education.
- MORLEY, H. J. & LAWRENCE, M. S. 1972a. The Use of Films in Teaching English as a Second Language.
- MORLEY, H. J. & LAWRENCE, M. S. 1972b. THE USE OF FILMS IN TEACHING ENGLISH AS A SECOND LANGUAGE. *Language Learnig*, 22, 99.
- MORLEY, J. 1980. The "nationwide" audience: structure and encoding. *Television Monographs*, 11. London: British Film Institute.
- MORLEY, J. 1986. *Family Television*, London, Comedia.
- MORRISON, K. R. B. 1993. *Planning and Accomplishing School-Centred Evaluation*, Dereham, U.K., Peter Francis.
- MOSER, C. A. 1958. *Survey Methods in Social Investigation*, London: Heinemann Educational Books Ltd.
- NANAN, M. 2004. Captioning and subtitling: Undervalued language learning strategies. *Meta*, 49, 67-77.
- NAVAS, M., GARCIA, M. C., SANCHEZ, J., ROJAS, A. J., PUMARES, P. & FERNANDEZ, J. S. 2005. Relative acculturation extended model (RAEM): New contributions with regard to the study of acculturation. *International Journal of Intercultural Relations*, 29, 21-37.

- NAYAR BHASKARAN, P. 1997. ESL/EFL Dichotomy Today: Language Politics or Pragmatics? *TESOL Quarterly*, 31, 9-37.
- NEUMAN, S. B. & KOSKINEN, P. 1992. Captioned television as comprehensible input: Effects of incidental word learning from text for language minority students. *Reading Research Quarterly*, 27, 95-106.
- NIU, Q., HAI, T. & WOLF, M. 2007. China EFL: Teaching with movies. *English Today*, 23, 39-46.
- O'MARA, J. 1991. Teaching intercultural communication through the Hollywood films: An analysis of "witness.". *Annual Meeting of the Eastern Communication Association*. Pittsburgh, PA: ERIC.
- O'SULLIVAN, T. 1998. Audiences and receptions. In: O'SULLIVAN, T., DUTTON, B. & RAYNER, P. (eds.) *Studying the media*
- OFFICIAL PLOT SUMMARY. 2001. Princess Diaries. *IMDB* [Online]. Available: <http://www.imdb.com/title/tt0247638/plotsummary> [Accessed 17 Jan 2007].
- OPPENHEIM, A. N. 1992. *Questionnaire Design, Interviewing and Attitude Measurement*, London, Pinter.
- OU, Y. 2009. 浅谈英文电影在提高大学生跨文化交际能力中的作用 Improving College students' intercultural communicative competence through English language films: a discussion. *电影文学 Movie Literature*, 06, 162-163.
- PAIGE, R. M. & GOODE, M. L. 2009. Cultural mentoring: International education professionals and the development of intercultural competence. In: DEARDORFF, D. K. (ed.) *The Sage Handbook of Intercultural Competence*. London: Sage.
- PAN, L. 1999. 电影在外语教学中的潜在作用 The potential of films in foreign language teaching. *广西民族学院学报(哲学社会科学版) JOURNAL OF GUANGXI UNIVERSITY FOR NATIONALITIES(PHILOSOPHY AND SOCIAL SCIENCE EDITION)*, 1, 246-247.
- PARKER, D. V. 1976. Adapting the Commercial Feature Film to the ESOL Student.
- PASQUIRE, D. 1996. Teen Series Reception: Television, Adolescence and Culture of Feelings. *Childhood*, 3.
- PATTON, M. Q. 1980. *Qualitative Evaluation Methods*, Beverly Hill, CA, Sage.
- PEARSON, R. P. 1977. Cross-cultural value conflict: Limiting the conception of multicultural education *International Journal of Intercultural Relations*, 1, 88-98.
- PERSE, E. M. 2001. *Media effects and society*, Mahwah, NJ, Erlbaum.
- PESNER, J. W. & AULD, F. 1980. The relationship between bilingual proficiency and self-esteem. *International Journal of Intercultural Relations*, 4, 339-351.
- PREETI, B., CARIN, Z. & CORINNE, B. 2010. Media Censorship in China. *Council on Foreign Relations* [Online]. Available: http://www.cfr.org/publication/11515/media_censorship_in_china.html [Accessed 11 Jan 2011].
- PRIEST, E. 2006. The future of music and film piracy in China. *BERKELEY TECHNOLOGY LAW JOURNAL* 21.
- RATHJE, S. 2007. Intercultural competence: The status and future of a controversial concept. *Language and Intercultural Communication*, 7, 254-266.
- RAY, M. L. 1973. Marketing communication and the hierarchy of effects. In: CLARKE, P. (ed.) *New Models for Communication Research*. Beverly Hills, CA: Sage.
- REBHORN, M. 1987. Hollywood films as a teaching tool. 76. Available: http://eric.ed.gov/ERICWebPortal/search/detailmini.jsp?_nfpb=true&_ERICExtSearch_SearchValue_0=ED286815&_ERICExtSearch_SearchType_0=no&accno=ED286815 [Accessed 05 Nov 2011].
- ROBSON, C. 1993. *Real World Research*, Oxford, Blackwell.
- ROGERS, E. M. & HART, W. 2002. The histories of intercultural, international, and development communication. In: GUDYKUNST, W. B. & MODY, B. (eds.) *Handbook of intercultural and intercultural communication (2nd Ed)*. Thousand Oaks: Sage.
- ROGERS, E. M. & SHOEMAKER., F. 1973. *Communication of innovations*, Glencoe, Free Press.

- RUDDOCK, A. 2001. *Understanding audiences: theory and method* London, Sage.
- RUHL, B. 1978. *ESL Teaching Techniques*, Volumes 1 and 2. 1978-00-00: Alberta Vocational Centre, Edmonton.
- RYAN, S. 1998. Using Films to Develop Learner Motivation. *The Internet TESL Journal* [Online], 4. Available: <http://iteslj.org/Articles/Ryan-Films.html> [Accessed 27 February 2010].
- SAMOVAR, L. A. & PORTER, R. E. 1972. *Intercultural communication: A reader*, Belmont, Wadsworth.
- SAVIGNON, S. 2005. Communicative Language Teaching: Strategies and Goals. . In: HINKEL, E. (ed.) *Handbook of research in second language teaching and learning*. U.S.A.: Laurene Erlbaum Associates.
- SCHEUFELE, D. A. & TEWKSBURY, D. 2007. Framing, Agenda Setting, and Priming: The Evolution of Three Media Effects Models. *Journal of Communication*, 57, 9-20.
- SERT, O. 2008. An Interactive Analysis of Hyperboles in a British TV Series: Implications For EFL Classes. 2008-00-00.
- SHANNON, C. & WEAVER, W. 1949. *The Mathematical Theory of Communication*, Urbana, University of Illinois Press.
- SHEA, D. 1995. Whole Movies and Engaged Response In the Japanese University ESL Classroom. In: CASANAVE, C. P., & SIMONS, J. DAVID. (ed.) *Pedagogical Perspectives on Using Films in Foreign Language Classes*. Fujisawa: Institute of Language and Communication.
- SHERMAN, J. 2003. *Using authentic video in the language classroom* Cambridge University Press.
- SHI, K. 2008. 英文电影欣赏——大学英语教学的思维转变 English language films appreciation - new ideas for College English teaching. *黑龙江科技信息 Heilongjiang Science and Technology Information*, 32, 166-167.
- SHI, Y. & LI, J. 2008. 英文电影欣赏与英语学习 English language film appreciation and English language learning. *电影文学 Movie Literature*, 06, 134.
- SIMONS, H. 1995. The politics and ethics of educational research in England: contemporary issues. *British Educational Research Journal*, 21, 435-450.
- SINO-BRITISH JOINT DECLARATION. 1984. Sino-British Joint Declaration. Available: http://en.wikisource.org/wiki/Sino-British_Joint_Declaration [Accessed 11 Jan 2011].
- SPITZBERG, B. H. & CUPACH, W. R. 1984. *Interpersonal communication competence*, Beverly Hills, CA, Sage.
- ST. MARTIN, G. M. 1978. *Films in the ESL Classroom*. 1978-06-00.
- STAIGER, J. 1992. *Interpreting Films*, New Jersey, Princeton University Press.
- STAIGER, J. 2005. *Media Reception Studies*, New York, New York University Press.
- STATE EDUCATION COMMISSION PRC 1996. The developmet and reform in Education in China. *International Conference on Education*. Geneva, Switzerland: SECPRC (State Education Commission People's Republic of China).
- STEMPLESKI, S., & TOMALIN, BARRY. 1990. *Video in Action: Recipes for Using Video in Language Teaching*, Prentice Hall International
- STEMPLESKI, S. 1987. Short Takes: Using Authentic Video in the English Class. 1987-04-00.
- STEMPLESKI, S. & ARCARIO, P. 1992. *Video in second language teaching: using, selecting and producing video for the classroom*.
- STEMPLESKI, S. & TOMALIN, B. 2001. *Film*, Oxford University Press.
- STOLLER, F. 1988. *Films and Videotapes in the ESL/EFL Classroom*. 1988-03-00.
- STORTI, C. 2009. Passing it on: Intercultural competence in the Training Arena. In: DEARDORFF, D. K. (ed.) *The Sage Handbook for Intercultural Competence*. London: Sage.
- STRAUBHAAR, J. 1999. Cultural captal, language, and cultural proximity in the globalization of television. *Paper presented at the annual meeting of Association for Education in Journalism and Mass communication (SEJMC)*. New Orleans.
- STRAUSS, A. & CORBIN, J. 1990. *Basics of Qualitative Research* Thousand Oaks, CA, Sage.
- SWAFFAR, J. & VLATTEN, A. 1997. A Sequential Model for Video Viewing in the Foreign Language Curriculum. *The Modern Language Journal*, 81, 175-188

- TAN, L. & SIMPSON, C. 1986. American TV and social stereotypes of Americans in Taiwan and Mexico. *Journalism Quarterly*, 63, 809-814.
- TANG, X. 2006. 英文电影欣赏对于英语视听教学的尝试 English language film appreciation and teaching English listening and speaking: an attempt. *文教资料 Education Material*, 17, 136.
- TATSUKI, D. 1992. Commercial movies versus ELT videos. *The Language Teacher*, 16, 17-21.
- THE GUARDIAN. 2006. China sinks dead man's chest. *The Guardian* [Online]. Available: <http://www.guardian.co.uk/film/2006/jul/10/news1> [Accessed 11 Jan 2011].
- THE NEW YORK TIMES. 2010. Internet censorship in China. *The New York Times* [Online]. Available: http://topics.nytimes.com/topics/news/international/countriesandterritories/china/internet_censorship/index.html [Accessed 11 Jan 2011].
- THE OXFORD ADVANCED LEARNERS' DICTIONARY 2003. Oxford University Press.
- TIAN, Y. 2009. 谈英文电影对大学英语禁忌语教学的促进作用 Teaching English taboo through English language films in College English classroom. *长春理工大学学报(高教版) Journal of Changchun University of Science and Technology(Higher Education Edition)*, 08, 86-87.
- TING-TOOMEY, S. 1999. *Communicating across cultures*, New York, Guilford.
- TING-TOOMEY, S. & KUROGI, A. 1998. Facework competence in intercultural conflict: An updated face-negotiation theory. *International Journal of Intercultural Relations*, 22, 187-225.
- TING-TOOMEY, S. 1981. Ethnic identity and close friendship in Chinese-American college students *International Journal of Intercultural Relations*, 5, 383-406.
- TOBIN, J. 2000. *Good Guys Don't Wear Hats: Children's talk about media*, New York, Columbia university.
- TONG, S. 2009. 论原版电影对西方文化导入的积极作用 Positive effect of using original English films in introducing western culture. *电影评介 Movie Review*, 03, 65.
- TRENAMAN, J. S. K. & MCQUAIL, D. 1961. *Television and the political image*, London, Methuen.
- TUCKMAN, B. W. 1994. *Conducting Educational Research (fourth edition)*, Orlando, FL, Harcourt Brace.
- VAN EK, J. 1986. *Objectives for Foreign Language Learning*, Strasbourg, Council Of Europe.
- VANDERPLANK, R. 1988. The value of teletext subtitling in language learning. *ELT Journal*, 42, 272-281.
- VISSCHER, J. 1990. Mixed-up media: Use and abuse of video in language teaching. *The Language Teacher*, 14, 5-9.
- WALFORD, G. 2001. *Doing Qualitative Educational Research: A Personal Guide to the Research Process*, London, Continuum.
- WALTON, G. 2001. *China's Golden Shield: corporations and the development of surveillance technology in the People's Republic of China*, Canada, International Centre for Human Rights and Democretic Development.
- WANG, C. 2001. 电影语言情景教学与学生英语交际能力的培养 Teaching English through films & improving students' communicative competence. *国际关系学院学报 Journal of University of International Relations*, 2, 62-66.
- WANG, X. 2009. 英文电影在英语教学中的应用 Using English language films in English language teaching. *科技信息 Science & Technology Information*, 05, 258-259.
- WANG, Y. 2010. 英文电影和歌曲对大学英语教学的促进作用 Assisting College English teaching by using English language films and songs. *科教文汇(中旬刊) Education forum*, 01, 85-86.
- WATTS, M. & EBBUTT, D. 1987. More Than the Sum of the Parts: Research Methods in Group Interviewing. *British Educational Research Journal*, 13, 25-34
- WAUTERS, R. 2009. China Blocks Access To Twitter, Facebook After Riots. Available: <http://www.washingtonpost.com/wp-dyn/content/article/2009/07/07/AR2009070701162.html> [Accessed 11 Jan 2011].
- WEI, G. 2008. *On the Reform of China's NCEE since 1977*. PhD, Hebei University.
- WEIMANN, G. 1984. Images of life in America: The impact of American TV in Isral. *International Journal of Public Opinion Research*, 8, 185-197.

- WILSON, C. C. 2002. Practical aspects of using video in the foreign language classroom. *The Internet TESL Journal* [Online], 5. Available: <http://iteslj.org/Articles/Canning-Video.html>.
- WILSON, N. & MCLEAN, S. 1994. *Questionnaire Design: A Practical Introduction*, Newtown Abbey, Co, Antrim: University of Ulster Press.
- WINTER, G. 2000. A comparative discussion of the notion of 'validity' in qualitative and quantitative research. *The Qualitative Report*, 4, 3-4.
- WOOD, D. J. 1992. JALT Video SIG Close Up. *The Language Teacher*, 16, 1.
- WOOD, D. J. 1997. Culture and Language Teaching through Movies--A Case Study. 1997-01-00.
- WOOD, D. J. 1999. Aspects of Video Movie English Teaching. *Journal of Chikushi Jogakuen University*, 11, 93-104.
- WU, J. 2009. 电影在英语听说教学中的应用 The role of films in teaching English listening and speaking. *电影评介 Movie Review*, 67-68.
- WU, Y. & MA, S. 2009. 英文原版电影与英语情景教学 Original English language films and situation-English-teaching. *电影评介 Movie Review*, 06, 69.
- XIAO, D. 2009. 论利用英语电影进行大学英语文化教学 On Using English Movie to Teach English Culture. *山西广播电视大学学报 Journal of Shanxi Radio & TV University*, 03, 72-73.
- YANCEY, G. 2009. Neither Jew nor Gentile: Lessons about intercultural competence in Religious Organizations. In: DEARDORFF, D. K. (ed.) *The Sage Handbook of Intercultural Competence*. London: Sage.
- YANG, N. 2009a. 英文原版电影在大学英语听力教学中的运用 Original English language films in College Listening and Speaking teaching. *工会论坛(山东省工会管理干部学院学报 Trade Unions Tribune(Journal of Shandong Institute of Trade Unions Administration Cadres)*, 01, 111-112.
- YANG, Q. 2009b. 巧用英文电影 促进大学英语教学 Effective ways of using English language films for College English teaching. *电影文学 Movie Literature*, 02, 128-129.
- YANG, Y. 2001. 电影语言与《英语视听说》教学 Film language and teaching English listening and speaking. *广西教育学院学报 Journal of Guangxi College of Education*, 6, 34-36.
- YOU, H. 2009. 多媒体与英文电影在大学英语教学中的应用 The implementation of multi-media and English language films in College English teaching. *中国新技术新产品 China New Technologies and Products*, 17, 240.
- YOUNG, I. & SERCOMBE, P. 2010. Communication, discourses and interculturality (special issue). *Language & Intercultural Communication*, 10.
- YUAN, Y. 2009. 英文电影在大学英语教学中的作用和优化设计 English language films in College English teaching: teaching plan and outcome. *襄樊学院学报 Journal of Xiangfan University*, 07, 83-87.
- YUAN, Z. 2000. 电影欣赏过程理论 Theory of process of film appreciation. *西南民族学院院报 Southwest University for Nationalities*, 3, 77-80.
- ZAHAROPOULOS, T. 1997. U.S. television and American cultural stereotypes in Greece. *World Communication*, 26, 30-44.
- ZANON, N. T. 2006. Using subtitles to enhance foreign language learning. . *Porta Linguarum*, 6.
- ZAREI, A. A. 2009. The effect of bimodal, standard, and reversed subtitling on L2 vocabulary recognition and recall. *Pazhuhesh-e Zabanha-ye Khareji*, 49, 65-85.
- ZHANG, D. 2009a. 语经典影视对白——“零课时”教学模式与英语专业听力教学 Teaching College English major's listening with classic English language film quotes. *和田师范专科学校学报 Journal of Hotan Teachers College*, 245.
- ZHANG, R. 2008a. 英文原版电影在大学英语教学中的开发利用 Original English language films in College English teaching: exploration. *电影文学 Movie Literature*, 21, 124.
- ZHANG, T. 2007. 谈英语听说教学中英文原版电影的几个处理技巧 Several Processing Techniques on English Original Films in English Listening and Speaking Teaching. *考试周刊 Exam Weekly*, 15, 55-56.

- ZHANG, T. 2009b. 论英文电影对大学英语教学的促进运用 Effective ways of teaching College English through English language films. *电影文学 Movie Literature*, 141-142.
- ZHANG, Y. & HARWOOD, J. 2002. Television viewing and perceptions of traditional Chinese values among Chinese college students.(Statistical Data Included) *Journal of Broadcasting & Electronic Media* 46, 245-264.
- ZHANG, Y. & XIAO, Z. 1998. *The Encyclopedia of Chinese film*, London, Routledge.
- ZHANG, Z. 2008b. 利用影视材料进行英美文化教学 Teaching British and American culture through films. *科技信息(科学教研) Science & Technology Information*, 11, 45.
- ZHAO, C. 2009. 利用英语电影进行文化教育 Teaching culture through English language films. *电影文学 Movie Literature*, 08, 151-152.
- ZHAO, X. 1989. Effects of foreign media use, government and traditional influences on Chinese women's values. *Revue Europeenne des sciences sociales*, 27, 239-251.
- ZHAO, X. 2002. 原版英文电影与英语教学 Authentic English language films and English language teaching. *辽宁师专学报(社会科学版) Liaoning Teachers college (Social Science)* 3, 75-76.
- ZHOU, J. 2009a. 大学英语教学中的英文电影欣赏 English language films appreciaton in College English teaching. *科技信息 Science & Technology Information*, 01, 231,261.
- ZHOU, Y. 2009b. 非语言符号在英语电影解读中的作用探析 Analysis of non-verbal signals in understanding English language films. *电影评介 Movie Review*, 15, 63-64.
- ZHU, X. 2009. 英语电影赏析有效促进大学英语教学 Positive effect of English language film appreciation on College English teaching. *消费导刊 Consume Guide*, 06, 174.
- ZHU, X. & WANG, R. 2008. 《老友记》作为英语口语教材的可行性探讨 The feasibility of Friends as English speaking teaching material. *语文学刊 Journal of Language and Literature Studies*, 19, 116-119.
- ZITTRAIN, J. & EDELMAN, B. 2002. Empirical Analysis of Internet Filtering in China Available: <http://cyber.law.harvard.edu/filtering/china/> [Accessed 11 Jan 2011].

