



# Proceedings of the EMII Research Symposium: Risk Management in Ireland

McMullan, C., & Brown, G.D. 2018, DCU, Dublin, Ireland

23<sup>rd</sup> February 2018



EMII



# Opening Address

Dennis Keeley  
Chairperson EMII

Join @ [www.emii.ie](http://www.emii.ie)



# **Paper One: Briefing The MEM Framework (2018)**

Keith Leonard

National Directorate for Fire & Emergency Management

Join @ [www.emii.ie](http://www.emii.ie)



Comhshaoil, Oidhreacht agus Rialtas Áitiúil  
Environment, Heritage and Local Government



# National Directorate for Fire and Emergency Management



An Stiúrthóireacht Náisiúnta um Dóiteáin agus Bainistíocht Éigeandála  
**National Directorate for Fire & Emergency Management**

# Review of “A Framework for Major Emergency Management” 2006



An Stiúrthóireacht Náisiúnta um Dóiteáin agus Bainistíocht Éigeandála  
**National Directorate for Fire & Emergency Management**

# Scope

- NSG approved a decision to review the existing Framework (22 September 2016)
- The aim of the review is to examine the structure and content of Framework (2006) and update the text to reflect the experience of the PRAs and other key stakeholders



An Stiúrthóireacht Náisiúnta um Dóiteáin agus Bainistíocht Éigeandála  
**National Directorate for Fire & Emergency Management**

# Objectives

- Review Framework structure & content in light of the existing Framework after 10 years
- Reflect on doctrine and underpinning concepts
- Move some existing material to Guides & Protocols
- Link to work at national level
- Drive some new concepts / address issues that have arisen
- Holding with existing strengths



An Stiúrthóireacht Náisiúnta um Dóiteáin agus Bainistíocht Éigeandála  
**National Directorate for Fire & Emergency Management**

Purpose of the Framework 2006 - Context

- Provide a systems approach to emergency management from the risk identification stage, through the planning and preparedness stages to response and the recovery stage
- Ensure that each stage of emergency management is co-ordinated
- Define a common language & terminology
- Simplify inter-agency working
- Provide a system for assigning a Lead Agency in every emergency situation





An Stiúrthóireacht Náisiúnta um Dóiteáin agus Bainistíocht Éigeandála  
**National Directorate for Fire & Emergency Management**

The principles that underpin the Framework (2006)

- Protection and care of the public at times of vulnerability
- Clear leadership in time of crisis
- Early and appropriate response
- Efficient and co-ordinated operations
- Transparent and accountable system of emergency management
- Safe working
- Promoting community resilience



An Stiúirthóireacht Náisiúnta um Dóiteáin agus Bainistíocht Éigeandála  
**National Directorate for Fire & Emergency Management**

## Areas identified for review

- Move emphasis from major emergencies to crisis management/ management of normal emergencies wider use of co-ordination system
- Move some material to Guides & Protocols
- Emphasis on public communication
- Develop an approach to community resilience
- Build in community volunteers
- Align terminology with EU CP system – Civil Protection
- Link to national system
- Capture recovery process
- Health & Safety – policy for inter-agency aspect response
- Examine the requirement to develop enabling legislation
- Build in experience of Storm Ophelia and other recent events



An Stiúrthóireacht Náisiúnta um Dóiteáin agus Bainistíocht Éigeandála  
**National Directorate for Fire & Emergency Management**

# Issues

- Legislation
- Prevention/ disaster reduction
- Public information
- Security
- Essential Services /CIP
- Technology/ Information systems
- Quality Assurance – Peer Review
- Resourcing & support



An Stiúrthóireacht Náisiúnta um Dóiteáin agus Bainistíocht Éigeandála  
**National Directorate for Fire & Emergency Management**

# Programme

- Due to complete fist draft text November 2017
- Delayed due to Donegal flooding, Storm Ophelia and other LGD response
- Research & Development
  - DCU Lit. Review complete April 2017
  - Examine lessons identified from exercises & reports
- Workshop x 8 with RSGs
- Developing text – Project Team
- Aiming for 1<sup>st</sup> draft text by Q1 2018



# Paper Two

## Methodology, Process & Outcomes: Delivering the National Risk Assessment 2017

Dr Caroline McMullan & Gavin D. Brown, DCU Business School

Eileen Tully, Department of Justice & Equality

Comdt Thomas Craven, Office of the Emergency Planning

Join @ [www.emii.ie](http://www.emii.ie)

# Methodology, Process & Outcomes: Delivering the National Risk Assessment (2017)

Dr Caroline McMullan & Gavin D. Brown, DCU

Eileen Tully, Department of Justice & Equality

Comdt Thomas Craven, Office of the Emergency Planning

# Previous Work

- National Risk Assessment 2012
  - Early stage assessment based on sound methodology from A ‘Framework’ for Major Emergency Management
  - First such assessment at national level
  - Accepted by EC as ‘best in class’
- BUT time passes ...
- Review & Update due for submission to EC
  - Opportunity to build on 2012 work and improve methodology
  - Greater alignment with international standard ISO 31000 desirable
  - Shortcomings in Impact criteria identified (fixed monetary values /casualty numbers). Relativity/Scalability needed
  - How to capture ‘uncertainty’?

# Methodology Must Be...

- Justifiable and appropriate to context
- Able to generate results which enhance understanding of the risks and how they can be treated
- Capable of use in a manner that is traceable, repeatable, verifiable
- Flexible enough to take inputs from different systems/departments/regions yet produce outputs that are comparable

(BS EN 31010:2010, p18)



## At all times...

- Assessed on the basis of reasonable worst case scenario
- “The most serious credible outcomes/consequences”

(BS EN 31010:2010, p85/3)

# Generation of the Initial Risk List

Data collected from:

- Regional Risk Registers
- Departmental Risk Registers
- National Agencies

# Consolidated Risk List

- Initial assessment used to identify and screen risks quickly.
- Clustering of risks should be “consistent and defined at the start of the” process. (BS EN 31010:2010, p86)
- “Based on qualitative methods and summary information at a broad scale”. This will help ensure that lower priority risks do not have disproportionate amounts of time and effort expended on the assessment process. (Australian Guidelines)
- First output - Consolidated Risk List

### **Hazard: Civil**

1. Infectious Disease
2. Terrorist Incident
3. CBRNe
4. Animal Disease
5. Foodborne Outbreaks
6. Waterborne Outbreaks
7. Cyber Attack
8. Crowd Safety
9. Civil Disorder
10. Loss of Critical Infrastructure

### **Hazard: Natural**

1. Storm
2. Flooding
3. Snow
4. Low temperatures
5. High temperatures
6. Volcanic Ash
7. Drought
8. Tsunami
9. Space Weather

### **Hazard: Transport**

1. Road
2. Rail
3. Air
4. Maritime
5. Transport Hub

### **Hazard: Technological**

1. Industrial Incident
2. Hazmat
3. Fire
4. Nuclear Incident (Abroad)
5. Radiation Incident (Domestic)
6. Disruption to electricity/gas supply
7. Disruption to oil supply
8. Disruption to Communication systems

# Risk Assessment

- “The goal ... is to establish a standard and therefore comparable measurement of the likelihood and consequence of every identified hazard”. (Coppola, 2007, p.114)

# Likelihood

# Likelihood Descriptors\*

Rating	Classification	Average Recurrence Interval
1	Extremely Unlikely	500 or more years between occurrences
2	Very Unlikely	100 - 500 years between occurrences
3	Unlikely	10 - 100 years between occurrences
4	Likely	1 - 10 years between occurrences
5	Very Likely	Less than one year between occurrences

\* For all but Terrorist Activity

# Terrorist Activity – Likelihood

- **Rating provided by the National Security Committee**

1. Low – An attack is deemed unlikely.
2. Moderate – An attack is possible, but not likely.
3. Substantial – An attack is a strong possibility.
4. Severe – An attack is highly likely.
5. Critical – An attack is imminent. (<http://www.irishexaminer.com/viewpoints/analysis/what-is-the-reality-of-the-threat-posed-by-islamic-extremists-in-ireland-396021.html>)

The threat is currently at moderate, upgraded from low last year.

<http://www.irishexaminer.com/viewpoints/analysis/what-is-the-reality-of-the-threat-posed-by-islamic-extremists-in-ireland-396021.html>



# Impact

Impact Category	1 Very Low Impact	2 Low Impact	3 Moderate Impact	4 High Impact	5 Very High Impact
<b>People</b>	Deaths less than 1 in 250,000 people for population of interest OR Critical injuries/illness less than 1 in 250,000 OR Serious injuries less than 1 in 100,000 OR Minor injuries only	Deaths greater than 1 in 250,000 people for population of interest OR Critical injuries/illness greater than 1 in 250,000 OR Serious injuries greater than 1 in 100,000	Deaths greater than 1 in 100,000 people for population of interest OR Critical injuries/illness greater than 1 in 100,000 OR Serious injuries greater than 1 in 40,000	Deaths greater than 1 in 40,000 people for population of interest OR Critical injuries/illness greater than 1 in 40,000 OR Serious injuries greater than 1 in 20,000	Deaths greater than 1 in 20,000 people for population of interest OR Critical injuries/illness greater than 1 in 20,000
<b>Environment</b>	Simple, localised contamination.	Simple, regional contamination, effects of short duration	Heavy contamination localised effects or extended duration	Heavy contamination, widespread effects or extended duration.	Very heavy contamination, widespread effects of extended duration
<b>Economic</b>	Up to 1% of Annual Budget	Greater than 1% of Annual Budget	Greater than 2% of Annual Budget	Greater than 4% of Annual Budget	Greater than 8% of Annual Budget
<b>Social</b> Consideration should be given to: Infrastructure; Community Services; Utilities; Evacuation/ Quarantine; Property/Housing; Supplies: Food, Water, Medicines; Civil Unrest; Public dissatisfaction	Limited disruption to community	Community functioning with considerable inconvenience	Community only partially functioning	Community functioning poorly	Community unable to function without significant support

# Confidence Level

# Confidence Level

- The goal is to capture the level of uncertainty present in the risk assessment
- Must capture this in order to interpret and communicate risk assessment results effectively (BS EN 31010:2010)

Refers to the:

- reliability, relevance and currency of the evidence/data
- input from appropriate experts
- level of agreement among assessors

# Confidence Levels

Confidence Level	Criteria
High ***	Assessment based on expert knowledge of the issue and/or reliable, relevant, current data. Consistent agreement among assessors.
Moderate **	Assessment informed by significant knowledge of the issue and/or limited reliable, relevant, current data. Broad agreement among assessors.
Low *	Assessment informed by limited knowledge of the issue and/or insufficient reliable, relevant, current data. Limited agreement among assessors.

# 6 x Focus Groups

# Focus Groups

- Representatives from Government Departments and Agencies with the knowledge, experience and seniority to contribute effectively to the focus group discussions identified.
- All focus group participants received a copy of the agreed consolidated risk list.
- In advance each participant gathered relevant data and feedback in relation to the likelihood of the identified hazards triggering a national level emergency and the national impact of the reasonable worst case scenario.

# Each focus group:

- (1) Determined the likelihood of occurrence of each hazardous event on the basis of the reasonable worst case scenario
- (2) Examined the current control/mitigation measures in place
- (3) Estimated the impact of the hazardous event on people, the economy, the environment, and the social impact in accordance with the agreed national impact criteria
- (4) Agreed the proposed risk score for each hazard.
- (5) In accordance with the national confidence level descriptors, agreed the confidence level for each risk score



# Focus Group

## 3 Key Outputs

- Reasonable worst case scenario (RWC)
- Estimation of Risk
  - likelihood & impact of RCW\*
- Confidence level for each risk assessment

\* “the probability relevant to the selected consequence (RWC) is used and not the probability of the event as a whole” (BS EN 31010: 2010, p.85)

# Threshold for Inclusion

- The aim of this NRA process is to determine the key national risks which require “a higher level of management” and to determine which risks “need not be considered further at this time” (BS EN 31010:2010 p.83).
- Risks rated as extremely or very unlikely and being of moderate impact or less and
- Risks rated as low or very low impact and which are considered to be unlikely to occur are not plotted on the 2017 National Risk Matrix.

# National Risk Matrix 2017

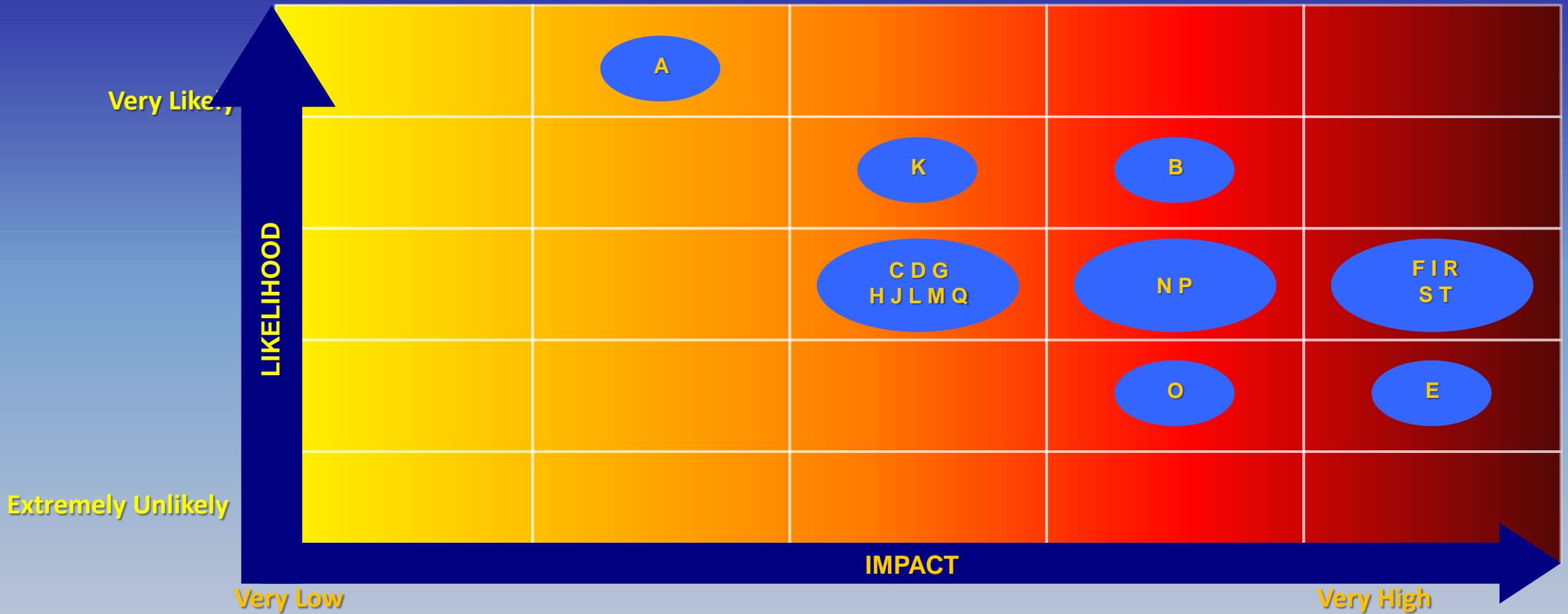

- A. Storm \*\*\*
- B. Flooding \*\*\*
- C. Snow \*\*\*
- D. Low Temp. \*\*\*
- E. Tsunami \*\*\*
- F. Infectious Disease \*\*\*
- G. Terrorist Incident \*\*\*
- H. Animal Disease \*\*\*
- I. Food Contamination \*\*\*
- J. Loss of Critical Infrastructure \*\*\*
- K. Rail Accident \*\*\*
- I. Aviation Accident \*\*\*
- M. Maritime Accident \*\*\*
- N. Transport Hub \*\*\*
- P. Hazmat \*\*
- O. Industrial Incident \*\*
- Q. Fire \*\*\*
- R. Nuclear Incident (Abroad) \*\*\*
- S. Disruption to Energy Supply \*\*\*
- T: Network & Information Security/Cyber Incident \*\*

Risk Assessment Confidence Levels:                      \*\*\* High Confidence                      \*\* Moderate Confidence                      \* Low Confidence

# Risks Below the Threshold for Inclusion

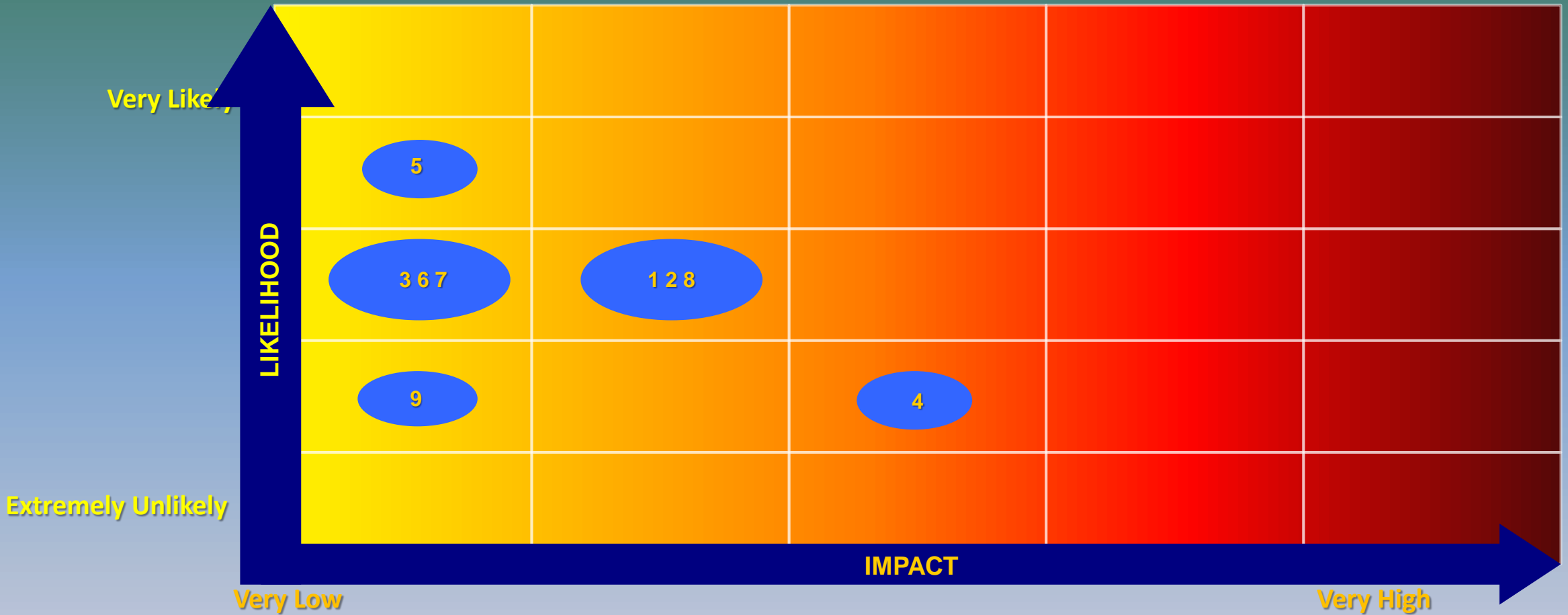

1. High Temperature \*\*\*

2. Volcanic Ash \*\*\*

3. Drought \*\*\*

4. Space Weather \*\*\*

5. Water Borne Outbreaks \*\*\*

6. Crowd Safety \*\*\*

7. Civil Disorder \*\*\*

8. Road Transport \*\*\*

9. Radiation (Domestic) \*\*\*

Risk Assessment Confidence Levels:

\*\*\* High Confidence

\*\* Moderate Confidence

\* Low Confidence

# NRA Risk Rating

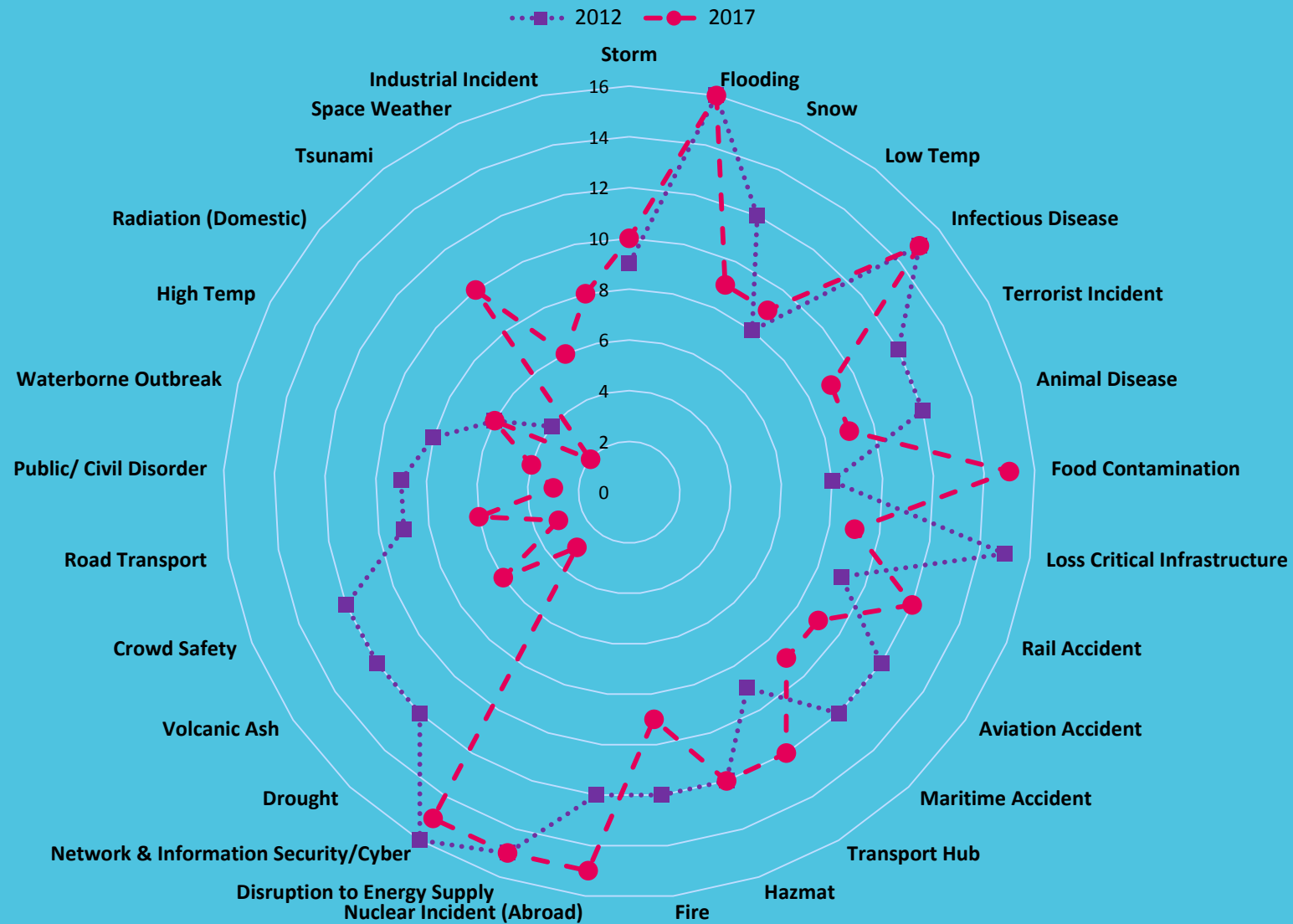

# Expert Assessment vs Public Risk Perception

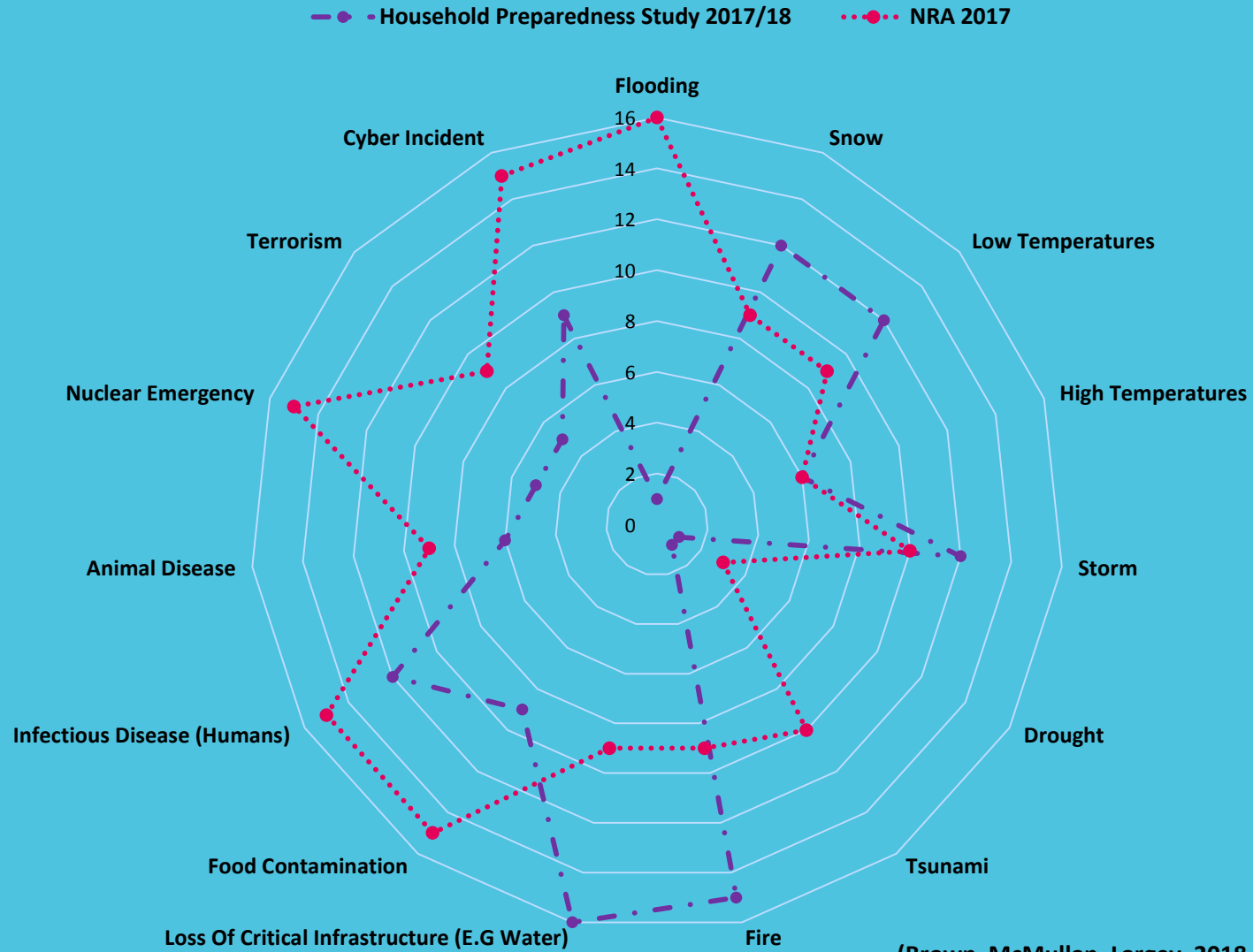

(Brown, McMullan, Largey, 2018, DCU Business School)

# References

If citing this presentation, please use the following format:

McMullan, C., Brown, G.D., Tully, E. & Craven, T., 2018, Methodology, Process & Outcomes: Delivering the Irish National Risk Assessment 2017. Emergency Management Institute Ireland Research Symposium. Dublin, Ireland.

- Australian Handbook 10, 2015. National Emergency Risk Assessment Guidelines. Australian Disaster Resilience Handbook Collection. Australian Institute for Disaster Resilience.
- Brown, G.D., McMullan, C., & Largey, A., 2018. A Study of Individual Risk Perception and Household Emergency Preparedness in Ireland. Dublin, Ireland.
- BS EN 31010 2010. Risk management: Risk assessment techniques. London: BSI Standards Publication.
- Coppola, D.P. 2007. Introduction to international disaster management. Boston: Butterworth-Heinemann.
- Coppola, D.P. 2015. Introduction to international disaster management. Boston: Butterworth-Heinemann.



# Paper Three Risk Management in Practice

Marie Sinnott & Derek Hynes ESB

Join @ [www.emii.ie](http://www.emii.ie)





Energy for  
generations

# Presentation to MSc in Emergency Management

## Risk Management in ESB

Marie Sinnott  
April, 2017

- **Introduction to ESB**
- **Oversight Arrangements**
  - Roles & Responsibilities
- **The Risk Management Process**
- **Group Risk Plan 2018**
- **Risk Appetite**
- **Business Continuity/Crisis Management**



<b>History</b>	<ul style="list-style-type: none"> <li>Established 1927, Vertically Integrated, 95% Government-owned. Markets Ireland &amp; UK</li> </ul>
<b>Networks</b>	<ul style="list-style-type: none"> <li>Owner of the Regulated Republic of Ireland T&amp;D networks (2016 RAB €7.5bn)</li> <li>Owner of the Regulated Northern Ireland T&amp;D networks (2016 RAB €1.6bn)</li> </ul>
<b>Generation</b>	<ul style="list-style-type: none"> <li>Portfolio 5.7 GW. All-Island Capacity 4.3GW and 47% Market Share. GB Capacity 1.4 GW</li> <li>Diversified fuel mix. Capacity &amp; Regulatory Supports</li> </ul>
<b>Supply</b>	<ul style="list-style-type: none"> <li>37% Market Share and 1.4 million Customers served on an All-Island basis</li> </ul>
<b>Innovation</b>	<ul style="list-style-type: none"> <li>International Engineering consultancy; Telecoms, Smart energy services and E-Cars</li> </ul>
<b>Financial</b>	<ul style="list-style-type: none"> <li>Regulated Networks Businesses account for ~ 66% of EBITDA and assets</li> <li>Solid EBITDA 2016 €1.32bn Assets €12.9bn Gearing 51%</li> <li>Strong Liquidity Position (2016 €1.7bn) and Stable Credit Ratings A- / Baa1 / BBB+</li> </ul>

- **Impact of Climate Change**
  - More frequent extreme weather events
  - Increased flood risks
- **Increased reliance on technology**
  - Smart homes, appliances
  - Growing threat of cyber crime
- **Interdependence of networks**
  - Electricity/telecoms/water/gas
- **Customer Expectations**





Energy for  
generations

## Risk Oversight Arrangements in ESB

***“... integrated business process essential to overall business success”***

- Risk awareness
  - Example & tone set at the top – risks expected to be considered
  - Everyone has responsibility for risk
  - Consistency of language
- Decision making is informed by a proper analysis of risk
  - Strategy and Business Plans are the foundation
  - Framework for risk identification, assessment & escalation
  - In accordance with Risk Management Policy
- The risk framework is designed to support the culture
  - Our Values and Purpose
  - Framework practiced in a consistent manner across all business units
  - Oversight & accountability

# Risk Management Policy & Governance Framework

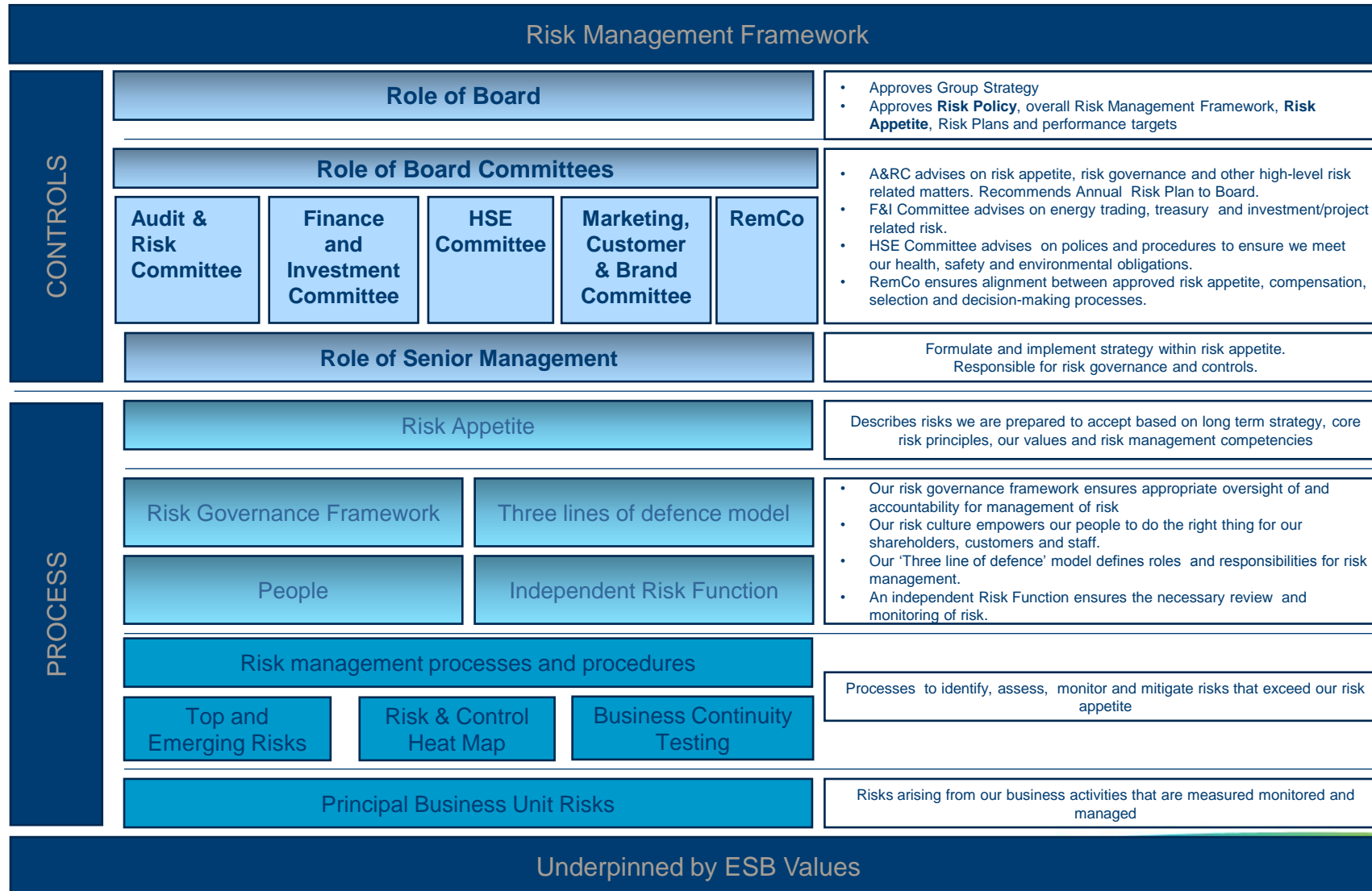

- **Oversight of the Risk Management Framework**
  - Is Strategy and Risk aligned?
  - Are the right policies, plans, resources in place?
  - Are they lived and implemented?
  - Do we have the right culture to address risk in the business?
- **Strategic oversight and guidance during a crisis**
  - Manage the crisis professionally
  - Establish immediate response strategies and tactics
  - Manage communication with stakeholders
  - Protect ESB's reputation



- **Is there an open and trusting relationship with the Chief Executive and the Senior Management Team?**
  - Is there a free flow of information sharing? Is the Board always kept informed?
  - Healthy challenge and debate?
  - A “no surprises” culture?
- **What is the level of engagement across the organisation? Are staff motivated and loyal?**
- **Are roles and responsibilities well understood? How are decisions made under pressure?**
- **Are there strong external relationships and networks in place that will support and sustain the business during a crisis?**
  - Can we leverage brand and reputation during a crisis? Are we in credit?
- **Does the business practice what it preaches when it comes to risk management?**

# Audit & Risk Committee Oversight

Action / Responsibility as per A&RC Terms of Reference and Risk Policy Framework	Suggested Frequency	Meeting Month												Comment
		January	February	March	April	May	June	July	August	September	October	November	December	
<b>Risk Responsibilities</b>														
<b>TOR 6 (b) (i)</b> Support the Board in carrying out the Board's responsibilities for ensuring that risks are properly identified, assessed, reported and controlled including advising the Board in its consideration of the overall risk appetite, risk tolerance and risk strategy of ESB Group	Annually	✓	✓											Risk Plan 2017
	Annually				✓									Risk Appetite Review 2017
<b>TOR 6 (b) (ii)</b> Review and recommend for approval to the Board the risk policy and risk management plan of ESB Group.	Annually												✓	2018 Principal Risks (with risk based Internal Audit Plan 2018)
	As required							✓						Risk Policy Review (if appropriate)
<b>TOR 6 (b) (iii)</b> Review the key risks of ESB Group and the adequacy of planned mitigation.	Quarterly				✓			✓			✓			Quarterly Risk Report
<b>TOR 6 (b) (iv)</b> Monitor the effectiveness of the risk management framework of ESB Group, ensuring its continued functioning and appropriateness and to review reports on any material breaches of risk limits and the adequacy of proposed action.	Bi-Annual								✓					Mid-Year Risk Review Update
	As Required				✓	Cyber					✓	Skill/ Talent		Deep Dives on specific risk areas (Topics as per Risk Plan 2017)
<b>TOR 6 (b) (v)</b> Review the arrangements for business continuity planning for ESB Group.	Annually												✓	Annual Report to A&RC on BC arrangements/activity
<b>TOR 6 (b) (vi)</b> Advise the Board on the need for periodic external review of the effectiveness of the risk management for ESB Group.	Quarterly				✓			✓			✓			Update on 2015 EY Review (in Quarterly Report)
<b>TOR 6 (b) (vii)</b> Ensure that the risk management function is adequately resourced and has appropriate standing within ESB Group.	Quarterly				✓			✓			✓			Reported by exception (in Quarterly report)
<b>TOR 6 (b) (viii)</b> Keep under review the adequacy and effectiveness of the ESB Group's financial and non-financial controls.	Annually	✓												Internal Controls Review
<b>TOR 6 (b) (ix)</b> Review and approve the statements on internal controls (IC) and risk management in the ESB Group Annual Report and in the financial statements of ESB Finance Limited.	Annually		✓											Review statement in ESB Group 2016 Annual Report
	Annually				✓									Review statement in 2016 Accounts for ESB Finance Ltd
<b>Risk Policy TOR:</b> Oversees the maintenance and development of a supportive culture in relation to risk	One per annum											✓	Metering	Site Visits



Energy for  
generations

## Risk Appetite

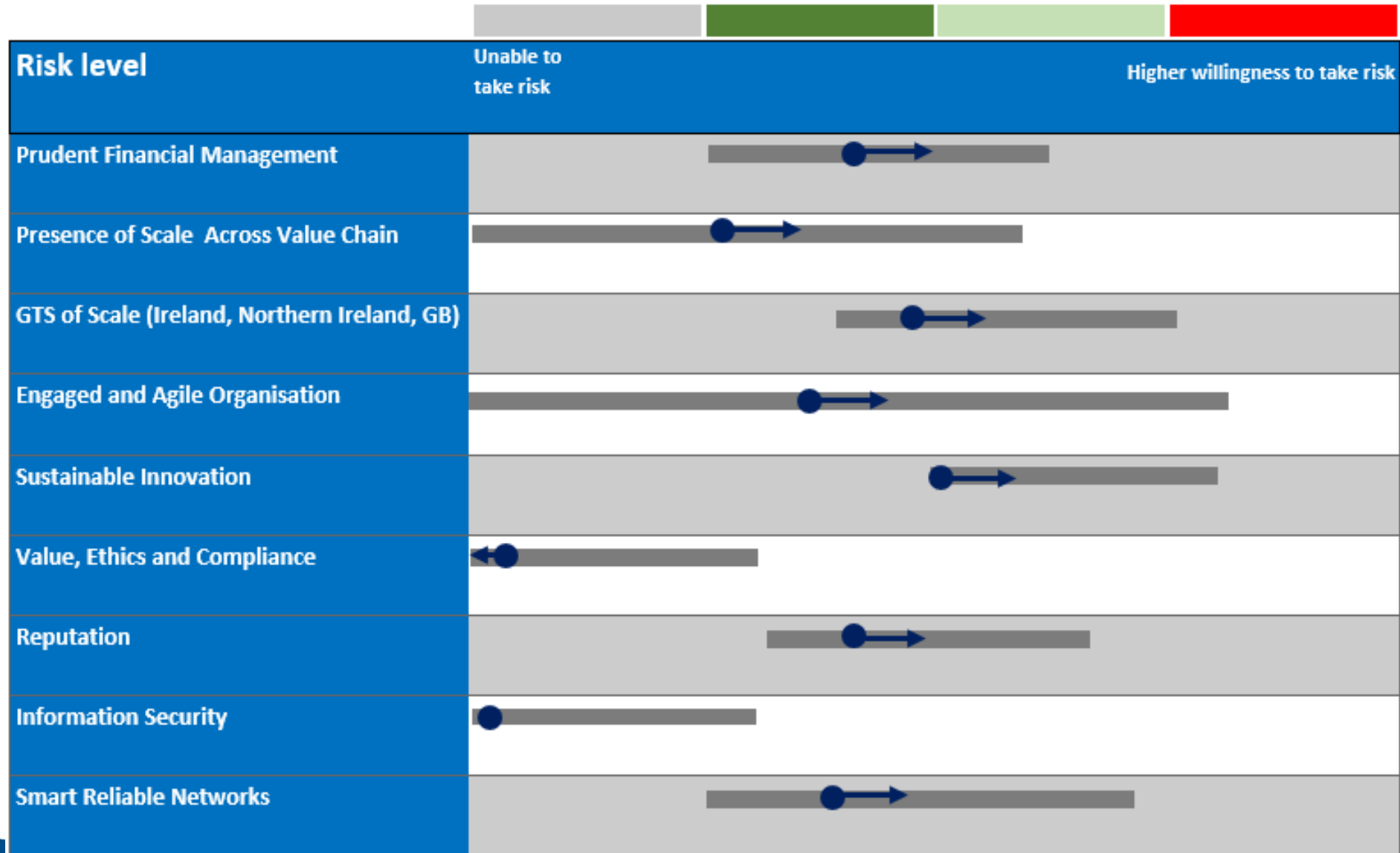





- **Risk Appetite is a statement of the Board's willingness to take risk/pursue opportunities to achieve strategic objectives**
  - A Statement of Intent – informs strategy and is informed by strategy
  - Has multiple dimensions/aspects
  - Set boundaries to risk taking – stretch for opportunity seeking
  - An aid to decision making
  - Used in context of assessing our Principal Risks



Energy for  
generations

## Group Risk Plan 2018

## ESB's Strategic Objectives reflect an underlying strategic intent...

Strategic Objectives					
Underlying strategic intent	<p>Put customers current and future needs at the heart of all our activities</p>	<p>Produce, connect and deliver clean, secure and affordable energy</p>	<p>Develop energy services to meet emerging market needs</p>	<p>Grow the business whilst maintaining ESB's financial strength</p>	<p>Deliver a high performance culture that supports innovation and collaboration</p>

# Principal Risks

Link to Strategy	Risk Climate	Safety & Environmental Risk	Financial Impact	Key Risk Indicators	Within Risk Tolerance	Responsibility
	↓	Risk of serious injury or death to staff, contractors or the public or damage to the environment resulting from our operations				ALL
Link to Strategy	Risk Climate	Risk / Opportunity	Financial Impact	Key Risk Indicators	Within Risk Tolerance	Responsibility
	↓					
	↔					
	↑					
	↑					
Link to Strategy	Risk Climate	Safety & Environmental Risk	Financial Impact	Key Risk Indicators	Within Risk Tolerance	Responsibility
	↓	Risk of damage to brand or reputation				ALL



- Boards need to accept that there are no guarantees
- Recovery as important as prevention

## Risk Bow-Tie

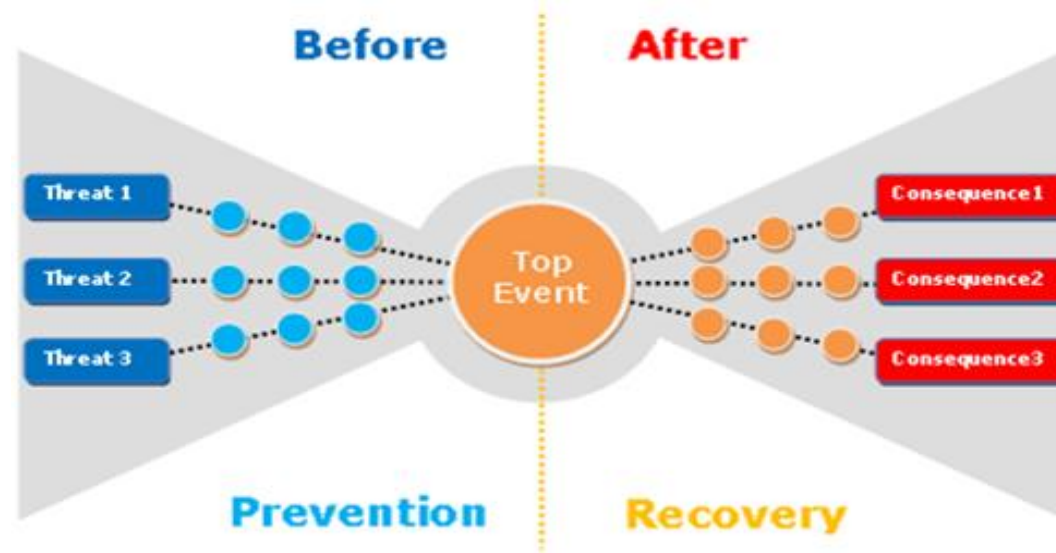

# Emerging Risks 2018

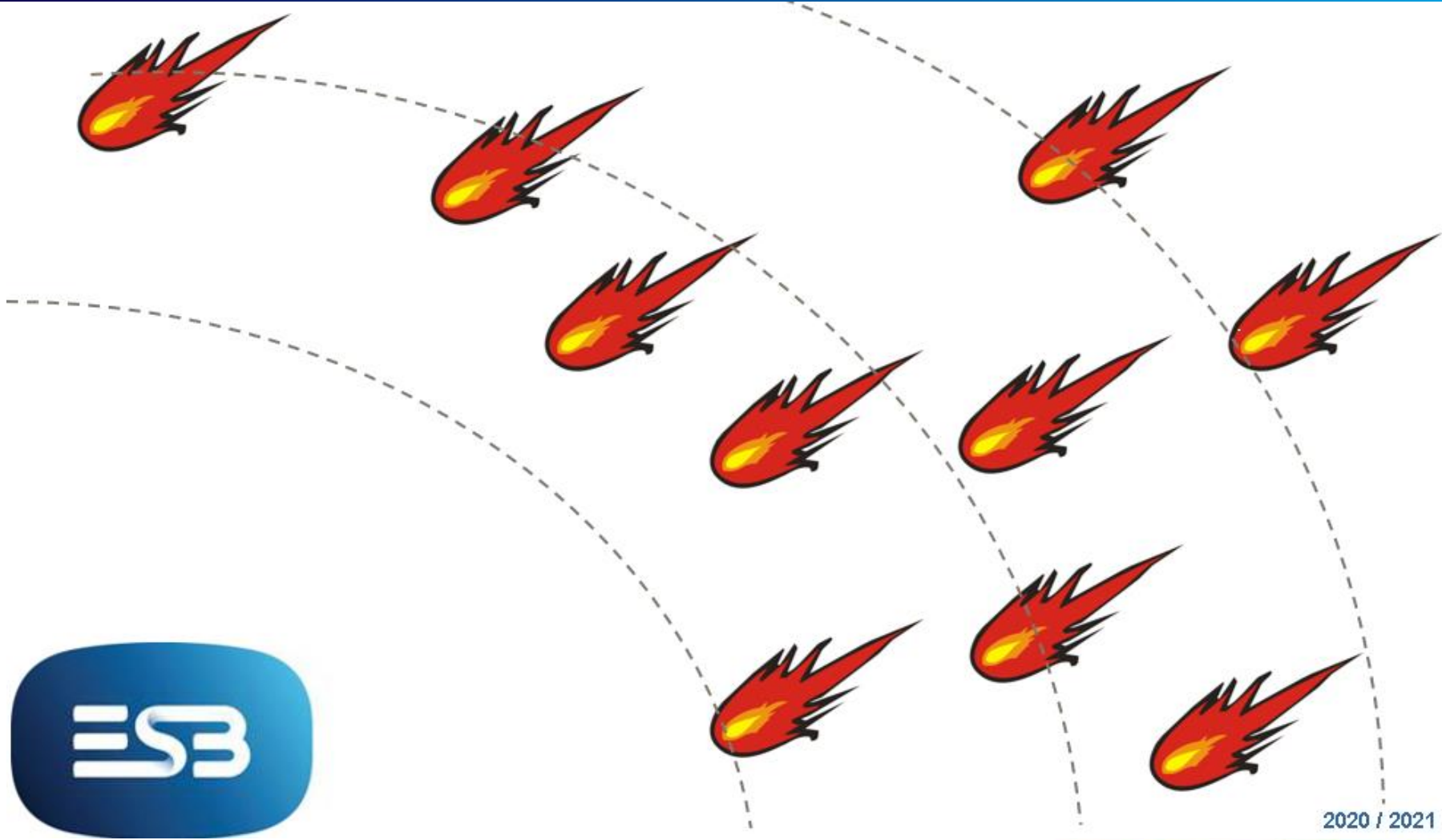

	HILP	Owner		HILP	Owner
Environmental	Major environmental disaster e.g.		Infrastructure	Sabotage / Terrorism / Major Explosion / Fire causing damage to critical plant/infrastructure	
				Significant Supply Chain Disruption / Third Party Dependency	
Governance / Finance	Material breach of financing facility			Severe Weather Event	
	Pension Risk				
	Governance failure/Major Fraud/Rogue Trader				



Energy for  
generations

# Business Continuity Planning and Crisis Management Framework

Owned by	Plan Type	Purpose
Health & Safety Organisation	<b>EMP (Emergency Management Plan)</b>	One plan exists for each significant building which deals with the initial alert and response. For example in the case of fire, our focus is on safety, damage limitation and security.
	<b>PPRP (Pandemic Preparedness &amp; Response Plan)</b>	A Group-level plan provides for ongoing monitoring of the threat level and for triggering appropriate responses in the event of a pandemic. More specific plans exist at BU levels which complement the Group PPRP.
	<b>Critical Incident Management Plan</b>	The requirements for managing critical incident situations affecting ESB staff, contractors and their families and to ensure that their needs are recognised and responded to in a timely and appropriate manner are set out in the ESB Group Policy for Critical Incident Management.
Business Continuity Framework & Structures	<b>WARP (Work Area Recovery Plan)</b>	One plan exists for each significant building, which provides for alternative accommodation. The focus initially is on relocating staff working on key processes.
	<b>BU BCPs (BU Business Continuity Plans)</b>	Typically one plan exists for each identified key process. This outlines how the local business team would recover and/or continue the business with reference to other plans.
	<b>CMP (Crisis Management Plan)</b>	A plan exists for each BU and for ESB Group; focus is on efficient information collection; communications (internal and external); high level decision making and overall Incident Management; provides for supports required in the event of serious injury or fatality.
CIO	<b>ITS-DRP (ITS Disaster Recovery Plan )</b>	One integrated plan, from ITS Group, exists for all of ESB covering system recovery on a prioritised, pre-agreed basis (Note: any locally managed systems are catered for in relevant BCPs).
	<b>ITS Cyber Security Incident Response Plan</b>	A plan, from ITS Group, exists for managing the response in the event of a cybersecurity incident

# Integrated Contingency Planning

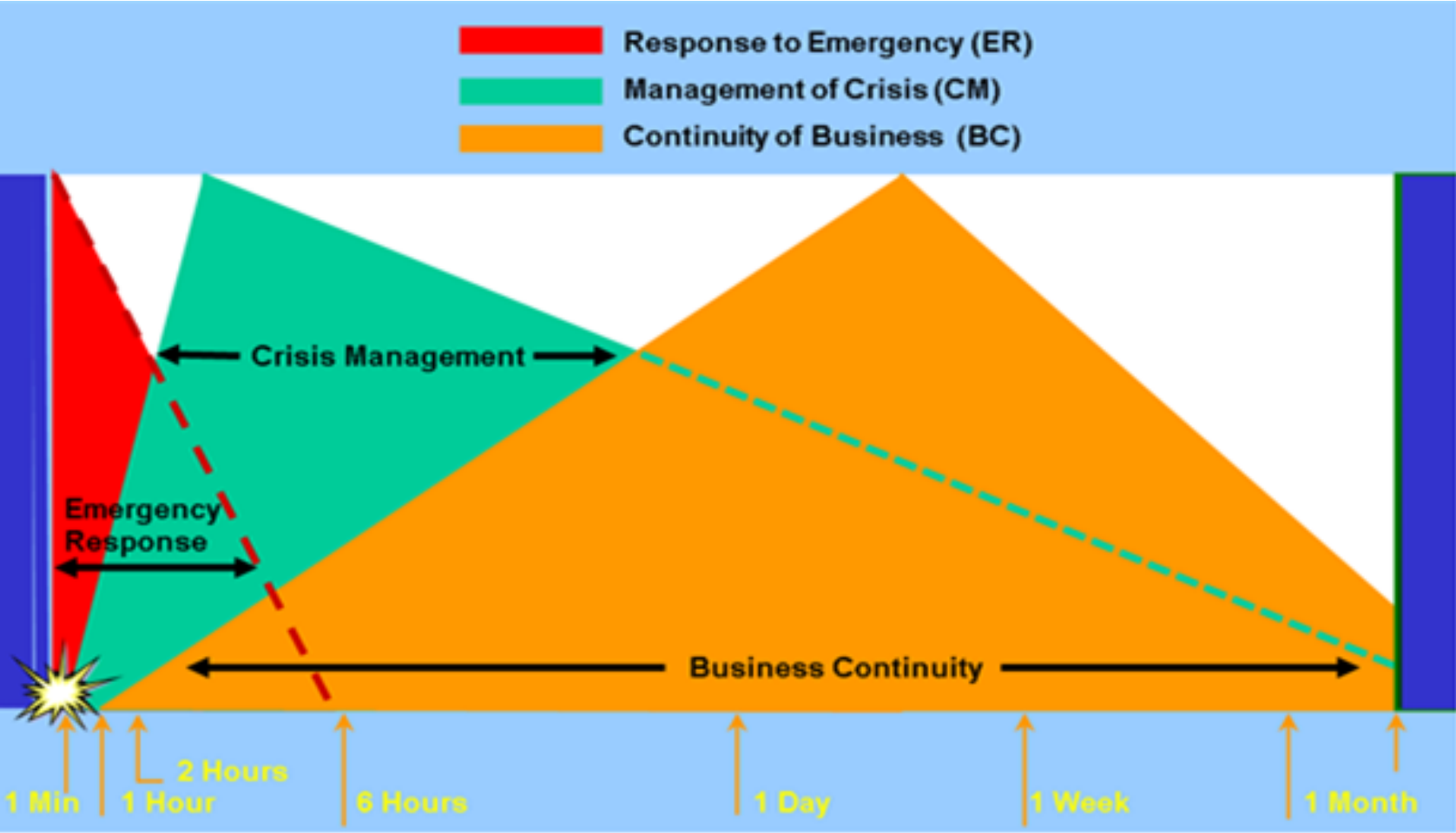

## Crisis Simulation

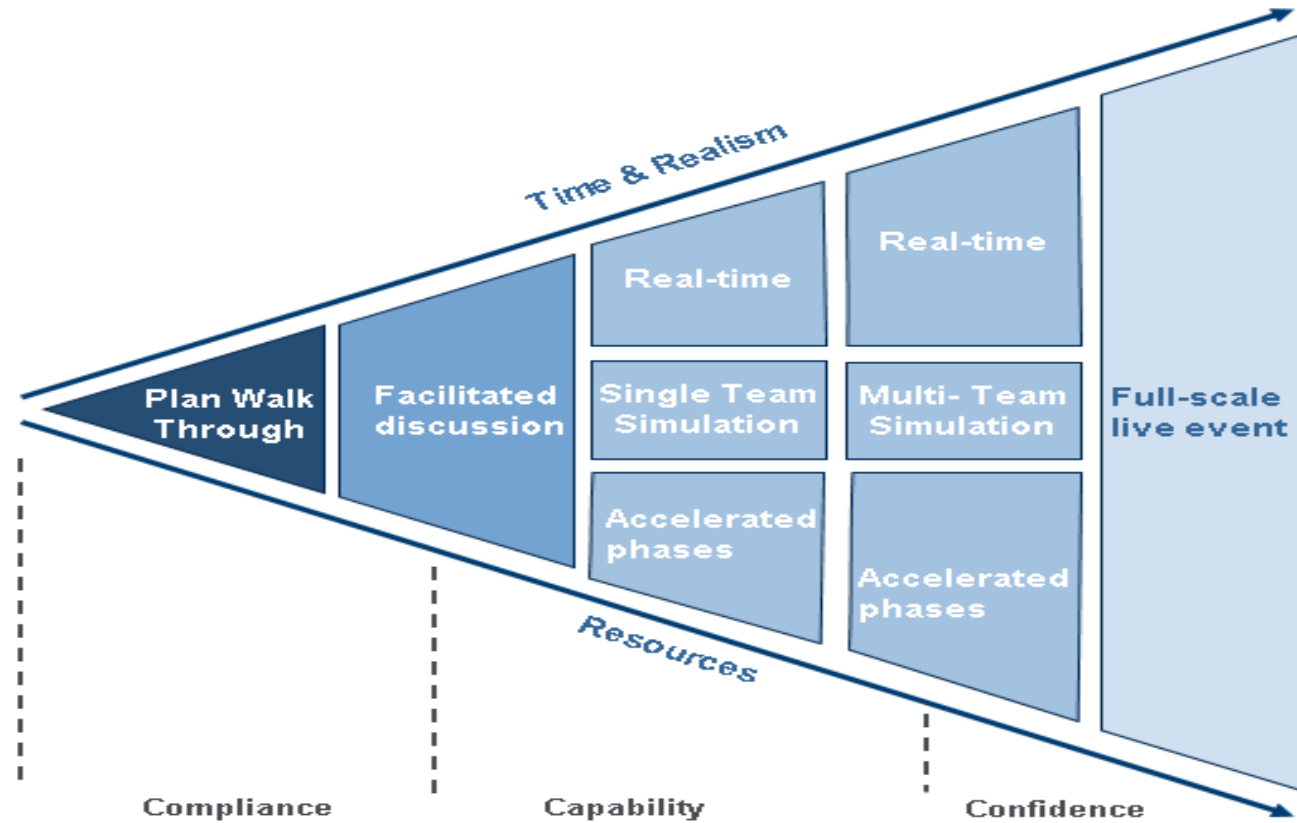

## Notification / Activation Criteria

- Safeguarding of human life or safety at risk ?
- A pan-ESB issue?
- Exceeds capacity of BU to contain/manage ?
- Damage or potential damage to the reputation of ESB?
- Contamination of the environment ?
- Significant interruption to supply or business activities ?
- Large scale negative Media interest / coverage ?

Exercise of Judgement



- **Leadership from the top is key**
  - Plan
  - Prepare
  - Practice
- **Speed of recovery**
- **Innovate to manage risk**
- **Expectations have never been higher**
- **Have you thought of what it would be like to have no electricity.....**



**NETWORKS**

# **Storm Ophelia ESB Networks Response**

**Derek Hynes**

**Operations Manager**

# Customers Impacted across the Country

At its peak 385,000 homes and businesses had no electricity

- South West 224,000
- Dublin South and South East 55,000
- Mid West 59,000
- Dublin North/Dundalk 36,000
- North West 11,000

There were over 5,500 individual fault locations  
It resulted in 11.7m Customer Hours Lost

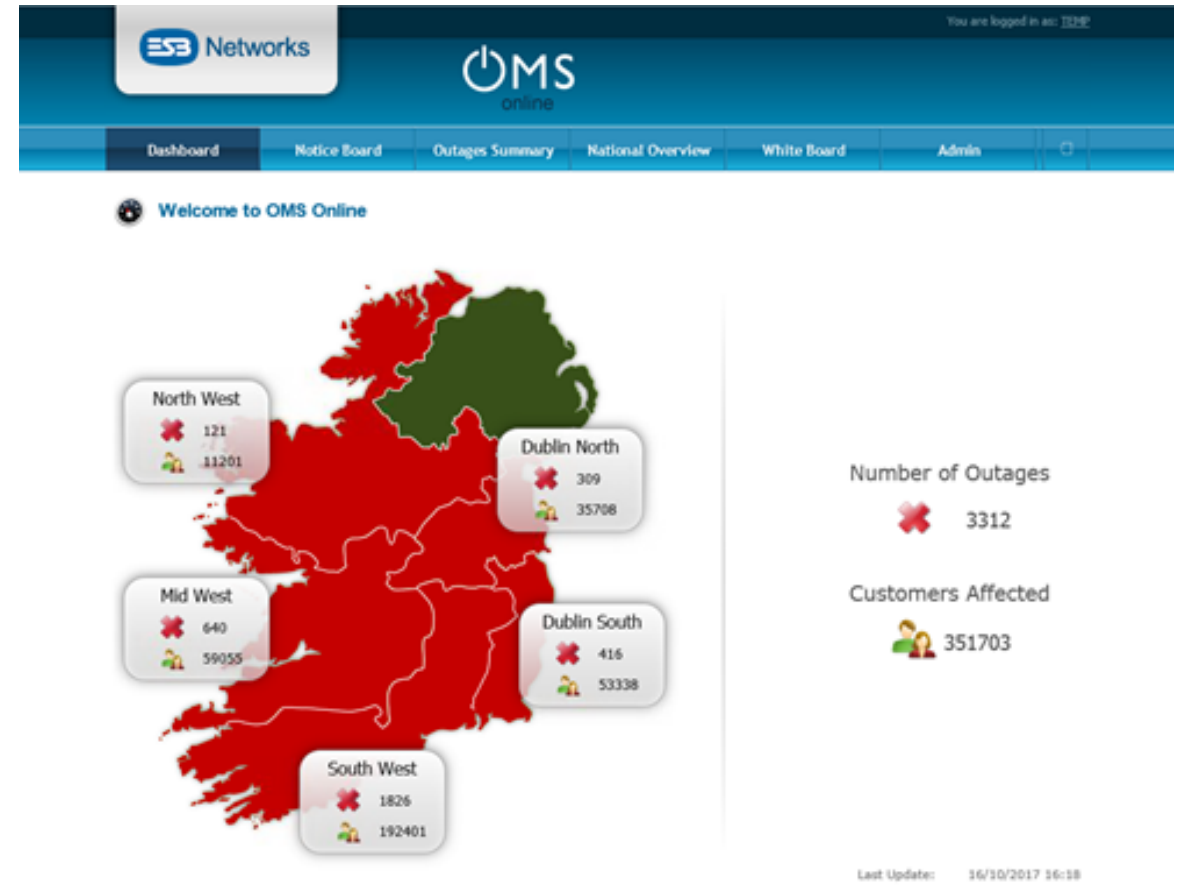

**BEFORE A STORM**

Supplies are out of stock or are in short supply. Start buying supplies for your home now. Check out the weather forecast for your area. If you're going to work or school, make sure you have a way to get home safely.

**WEATHER-READY CHECKLIST**

- Check for power outages. If you have a generator, make sure it's safe to use.
- Check for gas leaks. If you have a gas furnace, make sure it's safe to use.
- Check for water leaks. If you have a water heater, make sure it's safe to use.
- Check for roof damage. If you have a roof, make sure it's safe to use.
- Check for tree damage. If you have trees, make sure they're safe to use.
- Check for car damage. If you have a car, make sure it's safe to use.
- Check for pet safety. If you have a pet, make sure it's safe to use.
- Check for elderly and disabled. If you have elderly or disabled people, make sure they're safe to use.

**DURING A STORM**

Stay safe. Stay indoors. Stay away from windows, doors, and glass. Stay in a room with no windows. Stay in a room with the fewest windows. Stay in a room with the fewest doors.

**AFTER A STORM**

Check for damage. Check for gas leaks. Check for water leaks. Check for roof damage. Check for tree damage. Check for car damage. Check for pet safety. Check for elderly and disabled.

## Safety

**DISASTER PREPAREDNESS**  
THINGS TO DO BEFORE, DURING AND AFTER A TYPHOON

**BEFORE**

- Plan an escape route. If you're in a high-rise building, have a fire escape plan. Practice it regularly. Don't use an elevator.
- Check for gas leaks. If you have a gas furnace, make sure it's safe to use.
- Check for water leaks. If you have a water heater, make sure it's safe to use.
- Check for roof damage. If you have a roof, make sure it's safe to use.
- Check for tree damage. If you have trees, make sure they're safe to use.
- Check for car damage. If you have a car, make sure it's safe to use.
- Check for pet safety. If you have a pet, make sure it's safe to use.
- Check for elderly and disabled. If you have elderly or disabled people, make sure they're safe to use.

**DURING**

- Stay indoors. Stay away from windows, doors, and glass. Stay in a room with no windows. Stay in a room with the fewest windows. Stay in a room with the fewest doors.

**AFTER**

- Check for damage. Check for gas leaks. Check for water leaks. Check for roof damage. Check for tree damage. Check for car damage. Check for pet safety. Check for elderly and disabled.

## Information

Changing Rain and Snow Patterns

Stronger Storms

Higher Temperatures and More Heat Waves

Changes in Animal Migration and Life Cycles

More Droughts and Wildfires

Less Snow and Ice

Thawing Permafrost

Damaged Corals

Rising Sea Level

Warmer Oceans

Changes in Plant Life Cycles

## Restoration



Warning Level	Wind Speed (Mean km/h)	Gust Speed (km/h)	ESB Networks Response	Duration (Days)
<b>STATUS YELLOW - Be Aware</b>			0 - 5,000 customers without electricity	0
YELLOW level weather alerts are for weather conditions that do not pose an immediate threat to people or assets	50 to 65	90 to 110	Business as usual: Small scale localised network damage possible. Unlikely to have major impact on electricity supplies. Limited resource, customer and media impact.	
<b>STATUS ORANGE - Be Prepared</b>			5,001 - 30,000 customers without electricity	1 to 3
ORANGE level weather warnings can potentially impact on people in the affected areas and implies that recipients should prepare themselves	65 to 80	110 to 130	Business Readiness: Moderate network damage in locations where Orange Wind/Gust levels are experienced. May result in suspension of planned work. Moderate resource, customer and media impact.	
<b>STATUS RED - Take Action</b>			30,001 - 300,000 customers without electricity	3 to 10
RED level severe weather warnings implies that recipients take action to protect themselves and/or their assets	>80	>130	Emergency Response: Significant network damage in locations where Red Wind/Gust levels are experienced. Planned work will be suspended and additional resources will be required to repair damage. Severe resource, customer and media impact.	



# Before the storm...

## Day -4: Thursday Forecasts

Met Éireann Advisory issued on Thursday afternoon:

*A combination of a vigorous Atlantic weather system and the remnants of Hurricane Ophelia will pass close to Ireland on Monday, and has the potential to be a high-impact event in parts of the country. There is a lot of uncertainty as to the exact evolution and movement of this weather system during the coming four days, but storm-force winds, outbreaks of heavy rain, and very high seas are threatened. Met Éireann will maintain a close watch on the evolution and issue further advisories and warnings as these are warranted.*

## Day -3: 2pm on Friday - Emergency Plan Invoked

Saturday 14/10/17

Level Red for southwest & west (5 counties), orange for the rest of country.

*Ex-hurricane Ophelia is expected to bring severe winds and stormy conditions on Monday. Mean wind speeds in excess of 80 km/h and gusts in excess of 130km/h are expected, potentially causing structural damage and disruption, with dangerous marine conditions due to high seas and potential flooding.*

## Day -2: ESB Networks Crisis Management Meetings

Saturday morning and evening (Request assistance from UK on Saturday 9am)

## Day -1: 3pm Sunday

Networks Emergency Management Team Convene in Leopardstown

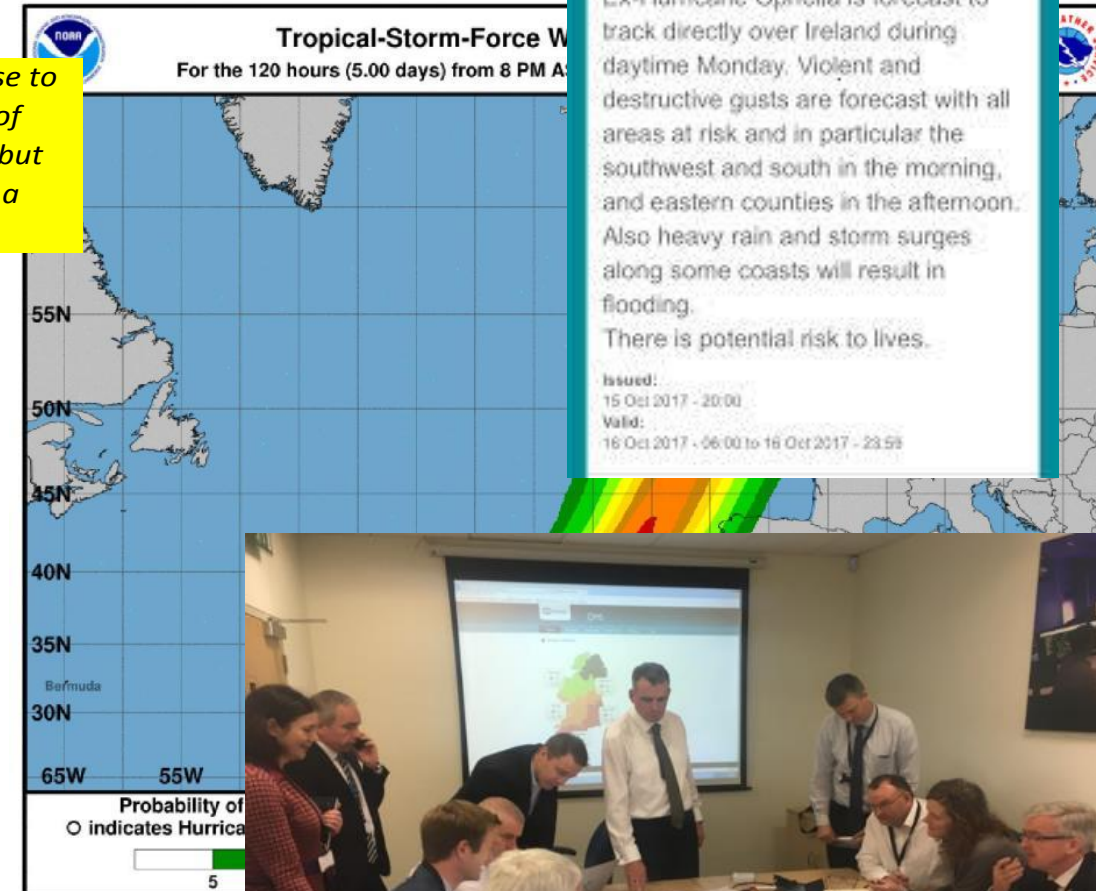

## National Co-Ordination

- NECG convenes Sunday 15<sup>th</sup> 10am
- Closure of Schools
- Extension of Red Warning to entire country
- Safety and Information
- ESB is a leader in this area





NETWORKS

# Storm Ophelia

Storm Ophelia's path across Ireland

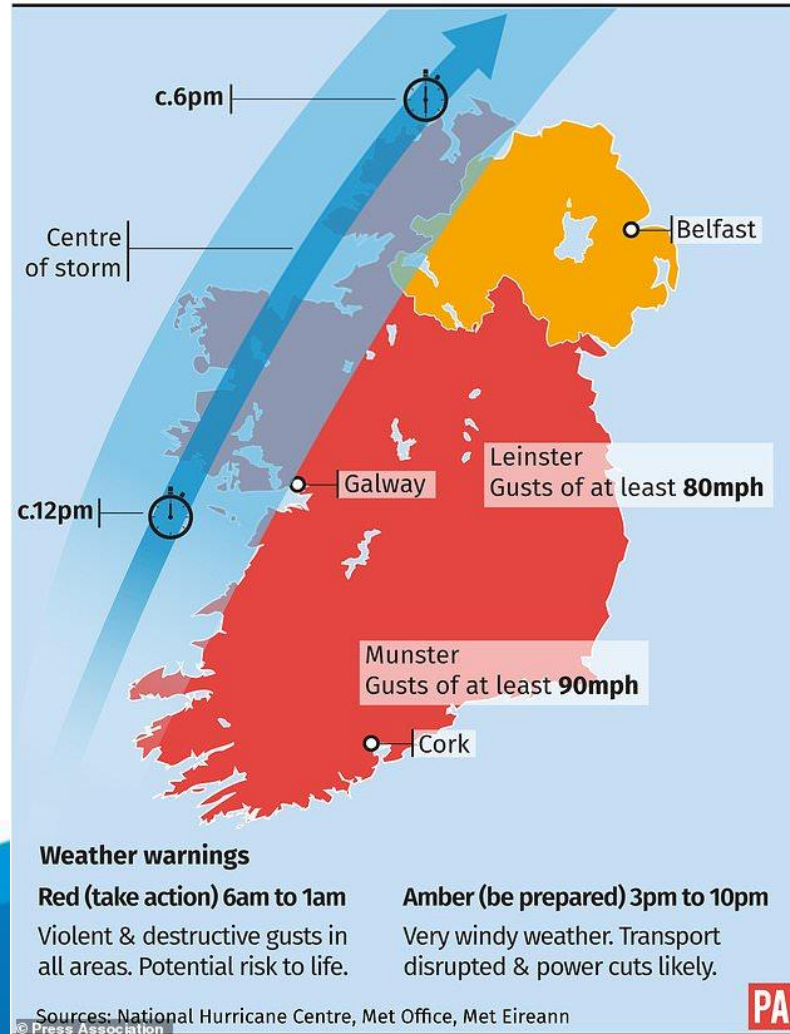



# Stormy Weather – During Ophelia

## Monday 16<sup>th</sup> October – Day 0

### Safety

- Public Safety
  - Stay Safe Stay Clear
  - Contact us
- Staff Safety
- Wait until the wind has passed

### Information

- NCEG meeting @10am/2pm/4pm
- Network Storm Co-ord group meet 8am/2pm/7pm
- NEWSAC Meeting 9am Requesting support from UK utilities
- Forecasted customer outage of 450k
- Damage Assessment and Prioritisation
- Signal intent for the rest of the week

### Restoration

- First fault at 07:45 Ballincollig Co Cork
- No work during the storm - remote operations via the Control Centre - FPE
- Work commenced at approx. 4 pm

Maximum Recorded Wind speeds (*Provisional*) during Monday 16 October 2017

STNO	Location	Name	Gust Speeds		Gust in hour ending (UTC)	10-min mean	
			knots	km/h		knots	km/h
	200ft above sea	Fastnet Light	103	190.8		78	144.4
952	Cork	Roche's Point	84	155.6	1100	60	111.1
	off-shore	Kinsale Platform	76	140.8	1500	60	111.1
951	Cork	Sherkin Island (lost at 0930)	74	137.0	0930	47	87.0
	Waterford	Waterford Airport	74	137.0		49	90.7
955	Cork	Cork Airport	68	125.9	1200	43	79.6
962	Clare	Shannon Airport	66	122.2	1200	41	75.9
967	Dublin	Casement	63	116.7	1500	39	72.2
956	Wexford	Johnstown Castle	62	114.8	1300	35	64.8
958	Cork	Moore Park(Fermoy)	62	114.8	1200	36	66.7
961	Carlow	Oak Park	60	111.1	1300	32	59.3
	off-shore	Buoy M2	60	111.1	1600	40	74.1
	off-shore	Buoy M5	59	109.3	1300	41	75.9
968	Meath	Grange (DUNSANY)	57	105.6	1400	28	51.9
980	Donegal	Malin Head	57	105.6	2000	39	72.2
	off-shore	Buoy M3	56	103.7	1500	41	75.9
961	Offaly	Gurteen	55	101.9	1300	35	64.8
978	Donegal	Finner	54	100.0	1700	35	64.8
953	Kerry	Valentia	53	98.2	1000	31	57.4
969	Dublin	Dublin Airport	53	98.2	1300	35	64.8
	Galway	Athenry	51	94.5	1300	31	57.4
963	Galway	Mace Head	51	94.5	0700	37	68.5
979	Cavan	Ballyhaise	50	92.6	1400	23	42.6
973	Mayo	Knock Airport	50	92.6	1500	32	59.3
975	Roscommon	Mount Dillon	50	92.6	1400	31	57.4
	off-shore	Buoy M4	49	90.7	1000	35	64.8
971	Westmeath	Mullingar	49	90.7	1400	26	48.1
976	Mayo	Belmullet	47	87.0	0800	26	48.1
	off-shore	Buoy M6	47	87.0	1500	33	61.1
970	Mayo	Claremorris	44	81.5	1300	26	48.1
984	Mayo	Newport	43	79.6	0600	22	40.7

# Unprecedented...

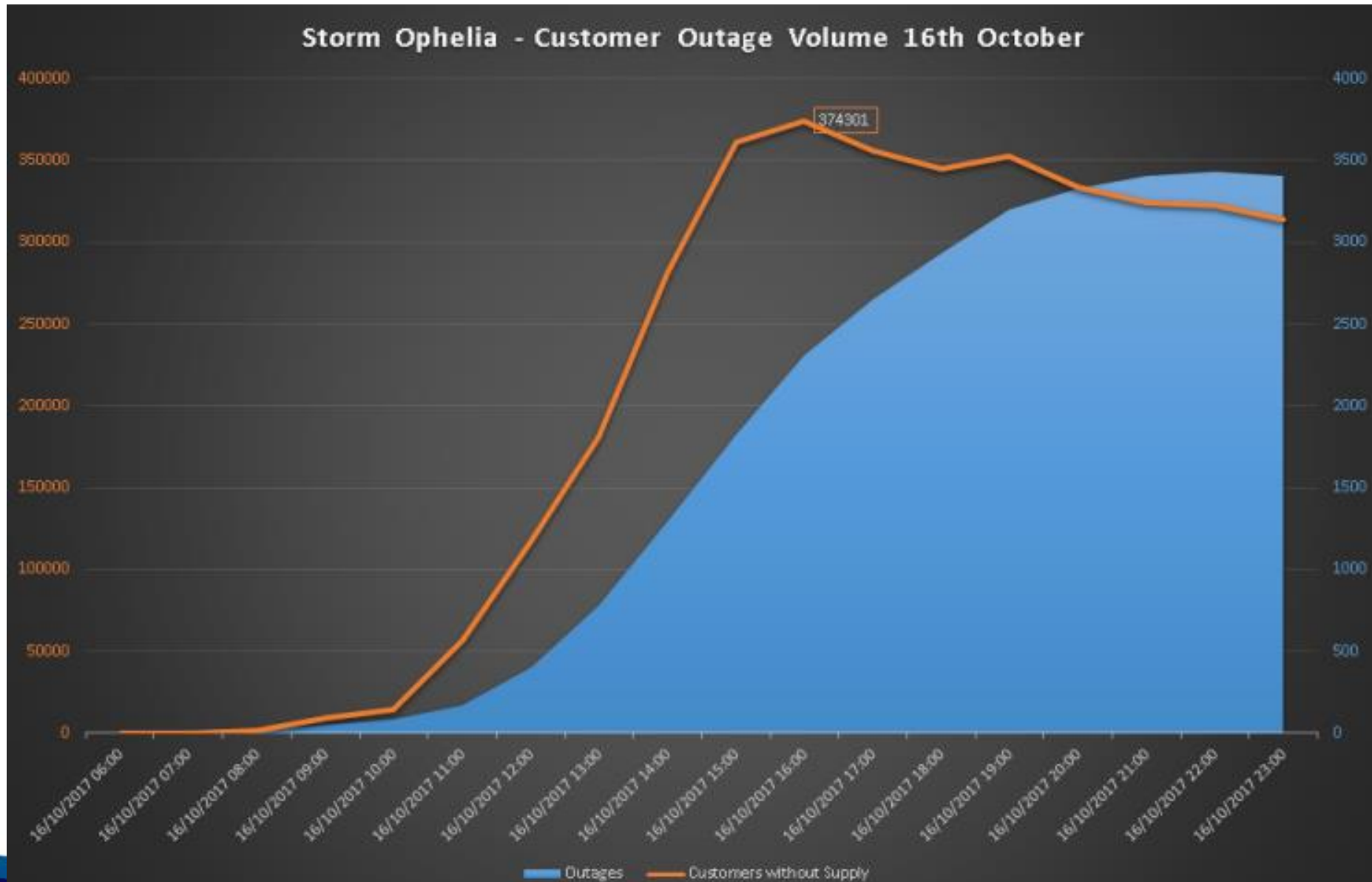



NETWORKS

AFTER THE STORM



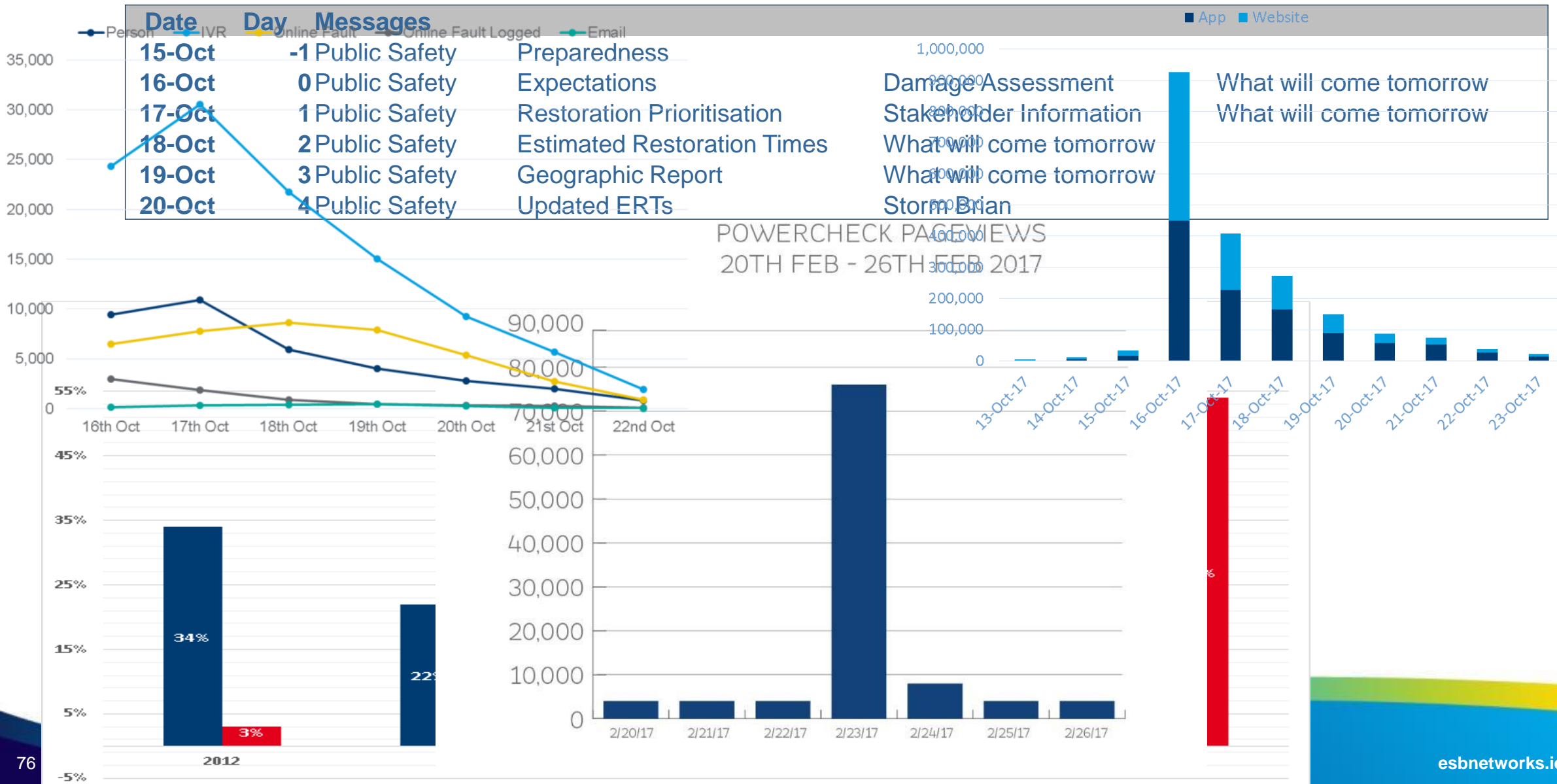

# Safety

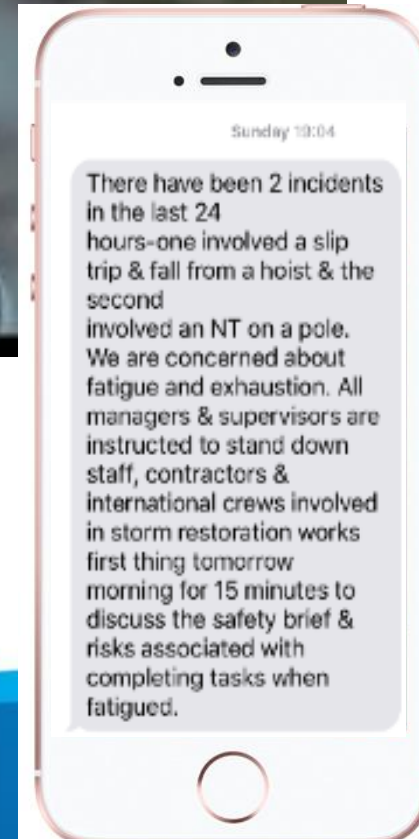

Falling timber caused this pole to lean to one side. While the timber was being cleared from around the leaning pole, from a hoist, the pole fell and narrowly missed the main body of the hoist. Upon inspection the pole was rotten beneath ground level.



← Before

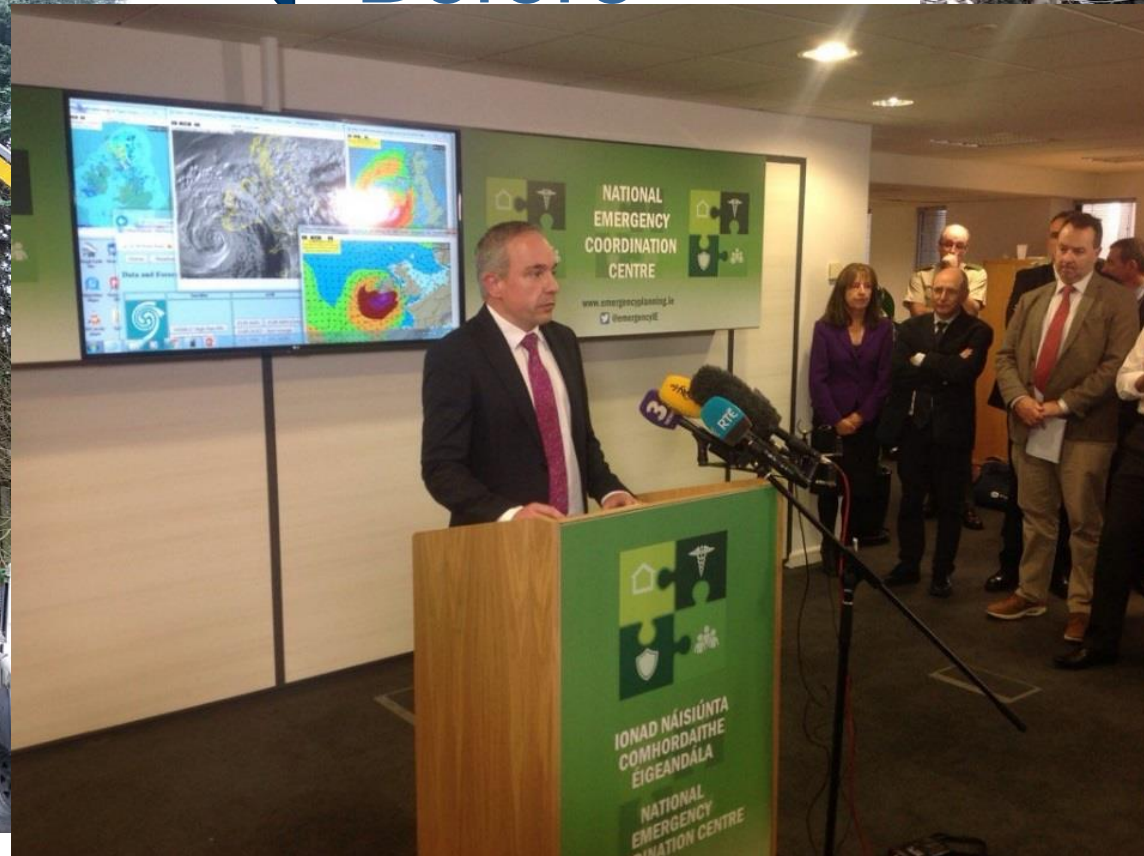

# Restoration

## Storm Ophelia - Customer Outage Volume

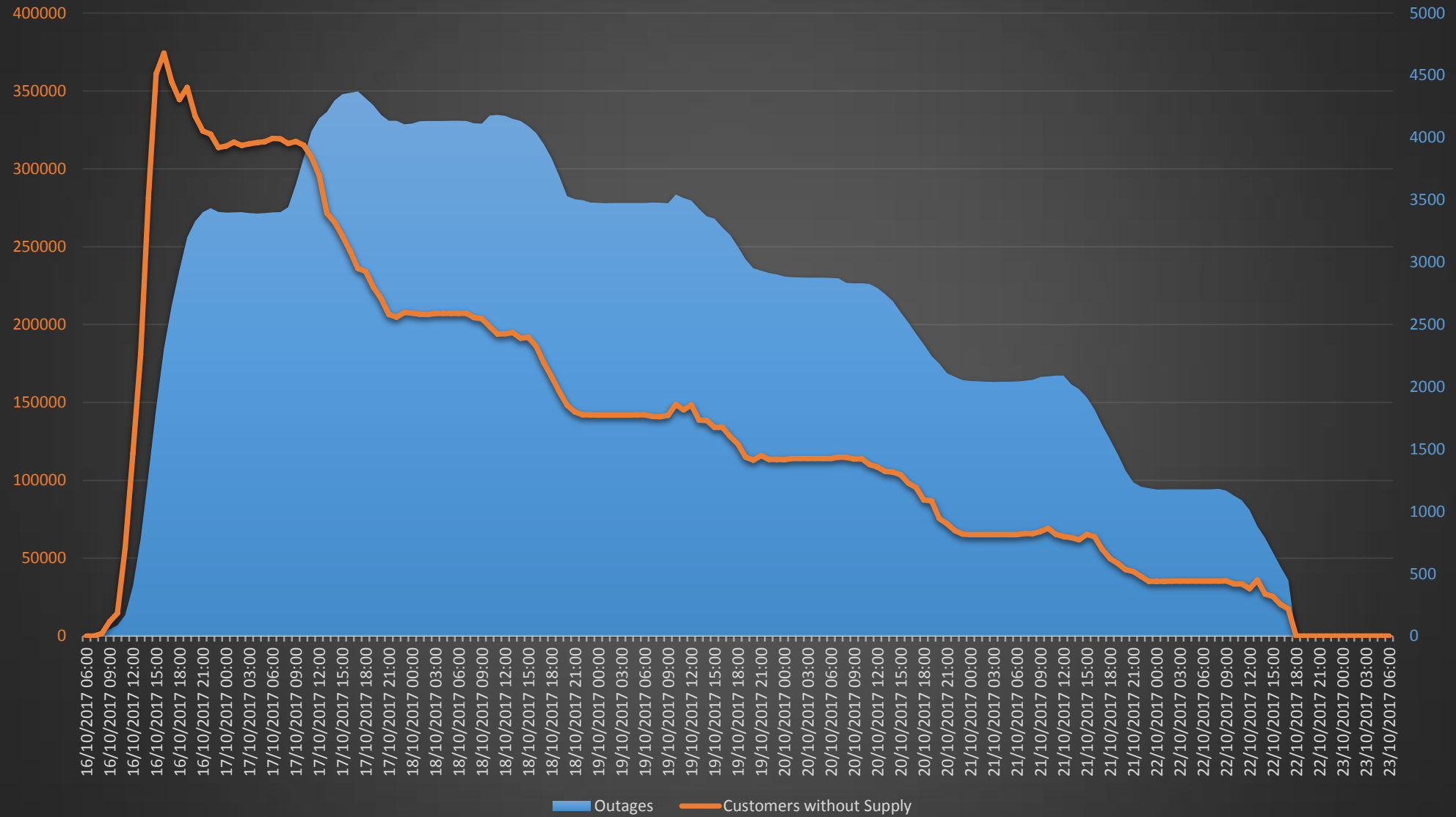

- 32 X 38kV circuit outage
- 2 X 110/38kV transformer
- 2 X 110kV transmission line
- 334 MV CBs open
- 69 FPE operations
- ?,000 LV Faults

# Mutual Aid



Company	Resources
NIE	187
Northern PowerGrid	16
WPD	37
Manx	5
Scottish Power	20
UK Power Networks	24
Electricity North-West	38
ENEDIS (France)	27
Morrison Utility Services	15
<b>Total</b>	<b>359</b>





NETWORKS

LESSONS  
LEARNED



- **Resources**

- Nothing gets done without people
- Army
- NEWSAC
- Contractors
- Organisation

- **Staff Safety and Welfare**

- Mobile drying units
- Daily Safety presentations & Safety Performance
- Food for depots
- Inductions in Training Centre
- Safety Briefings & Warnings to Public about fallen wires
- Stock of PPE
- Materials Management

- **Emergency Management**

- Responsibility splitting – stakeholder, operations, media, welfare, action log & lessons learned, resources, information, communications, customer, safety
- Devolved Control & Splitting areas
- Daily SMT conference calls + SMT experienced in weather events
- Help, support and interest from other parts of ESB

- **Customer and Stakeholder Management**

- Leixlip Contact Centre open early
- Information management
- Managing politicians
- Regular media & stakeholder briefings

- **Media**

- Extent of media interest

- **IT and Social Media**

- New OMS
- Data Analytics
- Depot, Worksite & MPRN Apps



NETWORKS

# The Future

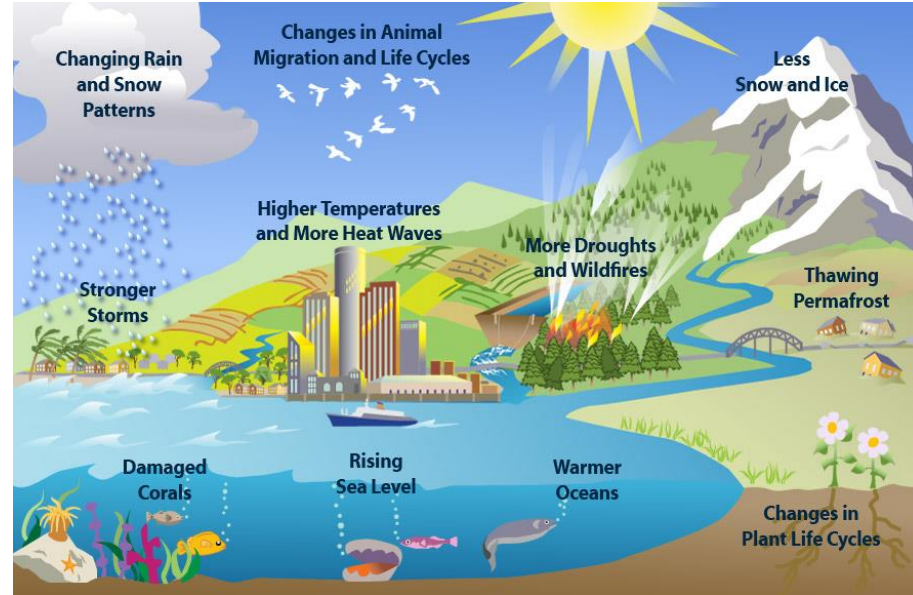



Energy for generations



# INNOVATING FOR A BRIGHTER FUTURE

ESB NETWORKS' INNOVATION STRATEGY



***“ESB Networks innovating towards a sustainable future for our customers and Ireland”***



## Current Carbon Emissions

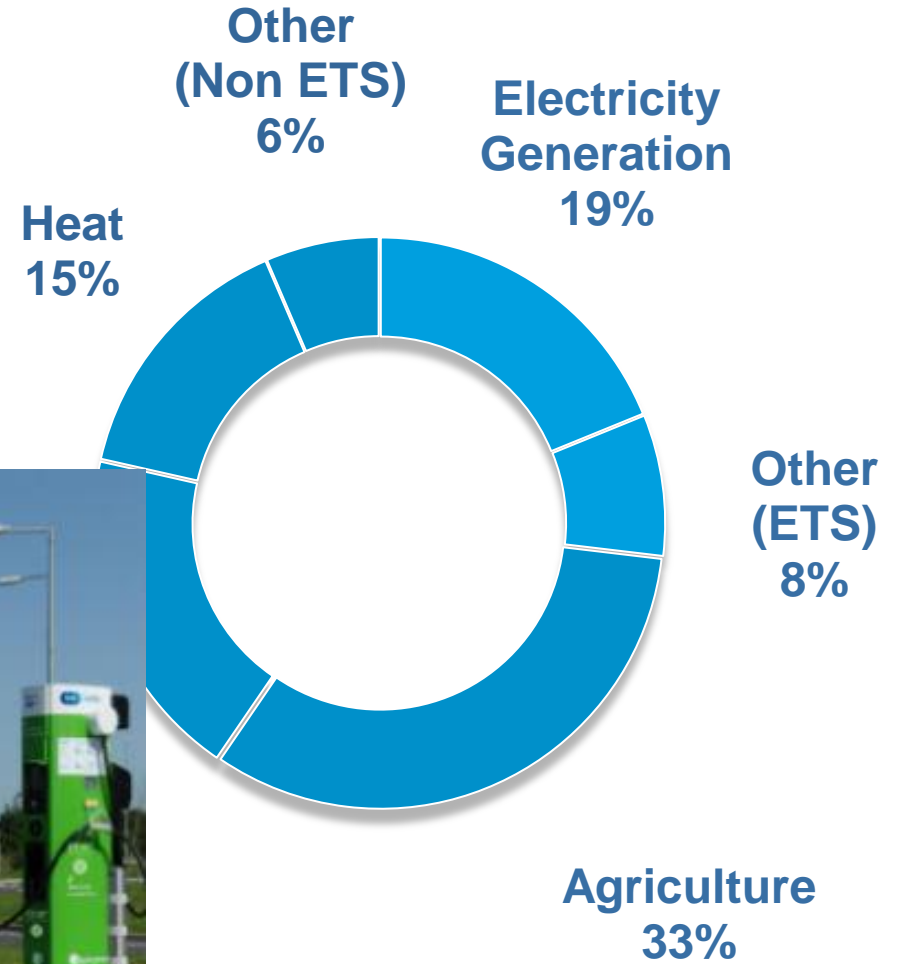

## Heating Mode

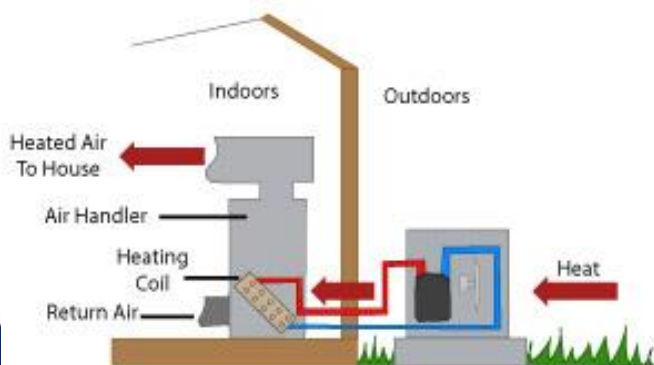



## Heating Mode

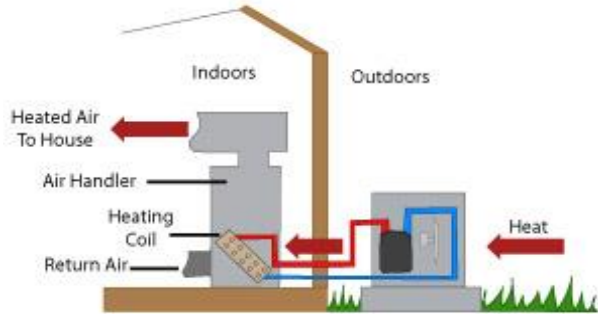

- Connection costs
- Capacity
- Reliability
- Convenience
- Ethics



- Taxation
- Manufacturer adoption
- Social acceptability
- Retrofits





# MID-CENTURY (2041-2060) PROJECTIONS EXTREME STORM TRACK

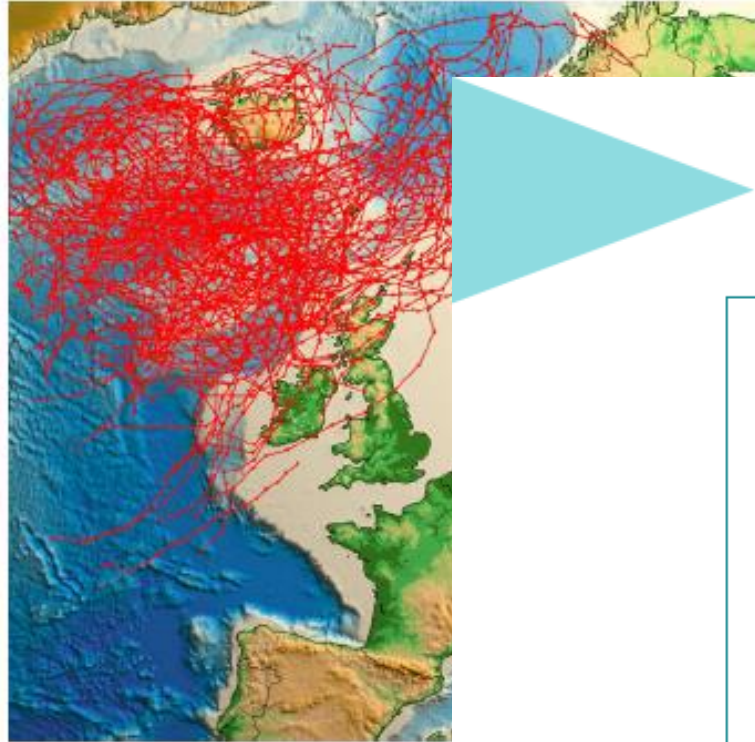

## THE MAIN POINTS

- Mean Temperatures will increase by 1-1.6 C by mid century
  - All seasons will be warmer
  - More 'hot' days, less frosts
  - Increased growing season length
  - More heatwaves, less cold spells
  
- A decrease in overall rainfall
  - Drier summer and spring seasons
  - More frequent days with heavy rain in winter and autumn
  
- A slight decrease in overall storm activity but an increase in the number of severe storms

# Continual Improvement

Figure 3.1 Population by age and sex, 2016

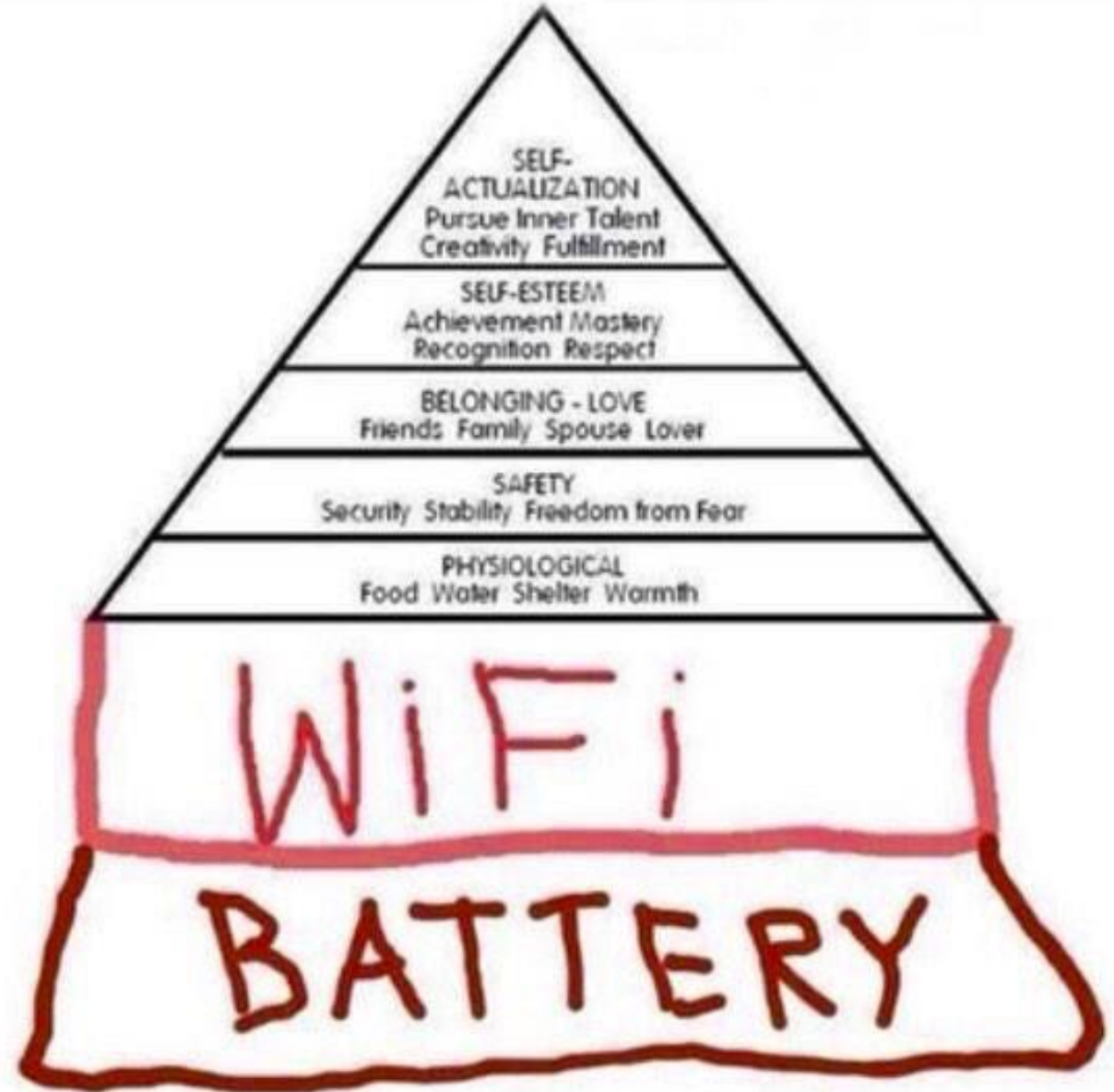
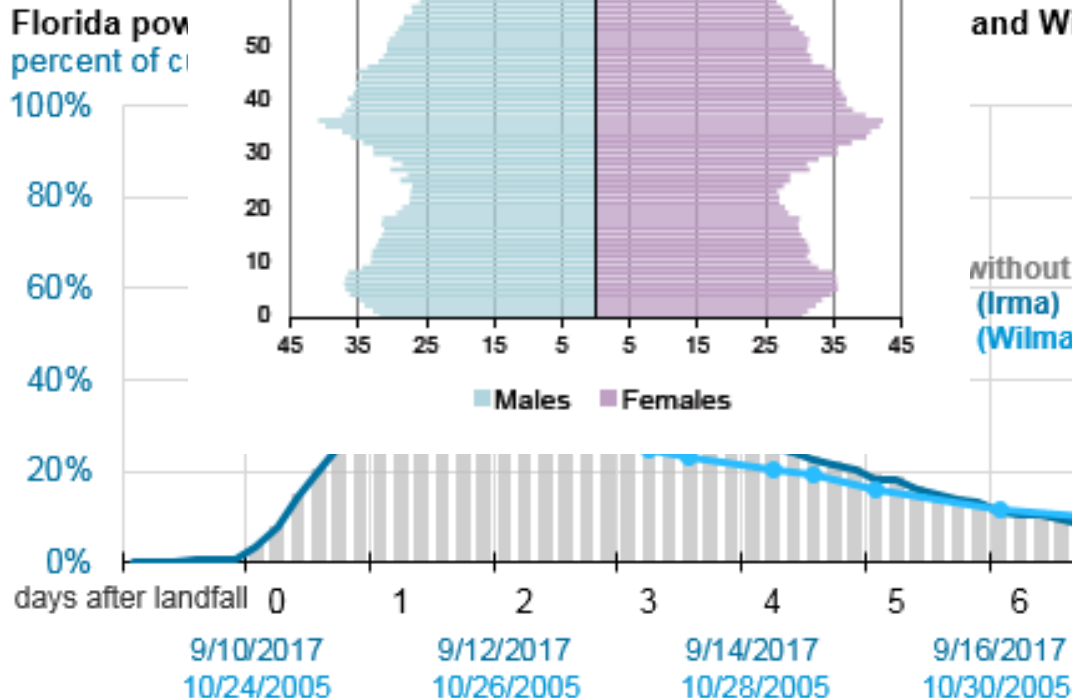
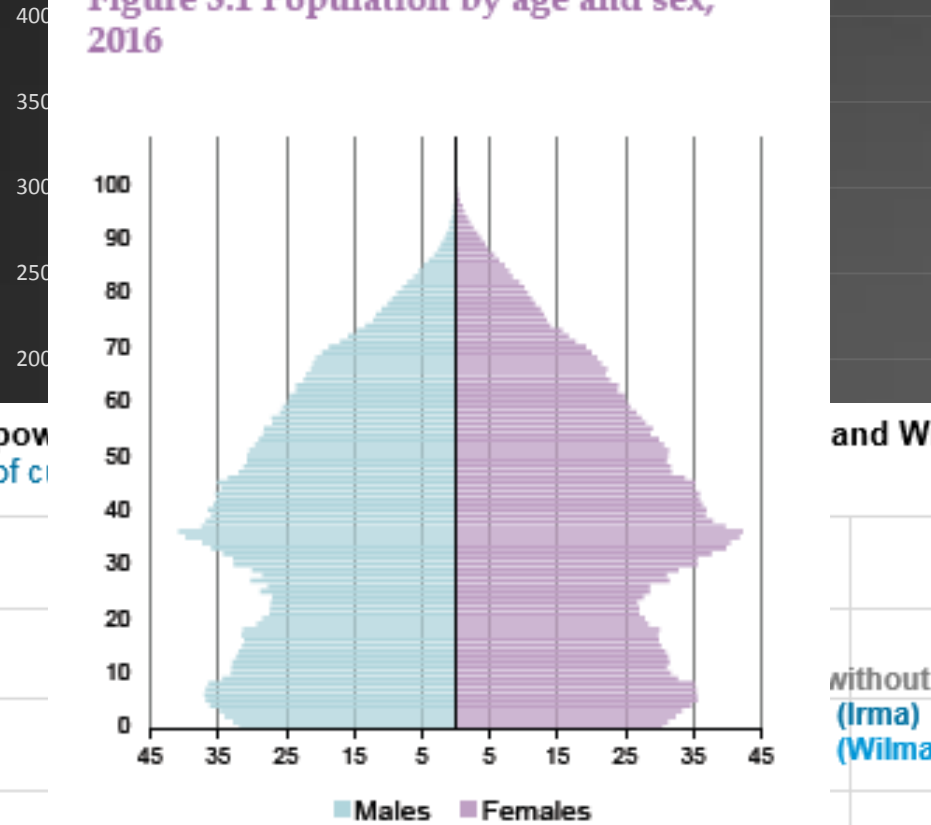

9/10/2017 11/1/2005 eia





NETWORKS

**Thank You**



# **Paper Four**

# **Defence Forces Approach to Strategic Risk**

Lt. Col Rossa Mulcahy & Comdt. Dave Lavin  
Defence Forces Ireland

Join @ [www.emii.ie](http://www.emii.ie)



# Irish Defence Forces Risk Management

**“Excellence is never an accident. It is always the result of high intention, sincere effort, and intelligent execution; it represents the wise choice of many alternatives – choice, not chance, determines your destiny”**

**Aristotle**



Lt Col Rossa Mulcahy





- > Introduction – Who we are and What we do
- > Risk Management (RM) Policy and Guidance Documents
- > Risk Culture Development
- > Defence Organisation RM – Strategic Context
- > Guiding Principles DF SRM Processes & Policy
- > Scope of the Defence Forces (DF) RM
- > RM for Operations
- > Summary
- > Questions?



- > Early 2000's heightened awareness of RM.
- > The Public Sector and Defence Organisation was not immune to the changing landscape.
- > Increased governance and accountability were necessary.
- > Utilisation of guidance documents to support the 'new' RM frameworks.



Óglaigh  
na hÉireann  
DEFENCE FORCES IRELAND

# The 'Defence Organisation'

Defend | Protect | Support



Minister  
Kehoe



Secretary General  
Quinn

Secretary  
General

Chief of  
Staff



Vice  
Admiral  
Mellett

MANAGEMENT  
BOARD

SMC

GENERAL STAFF

# Combat Units

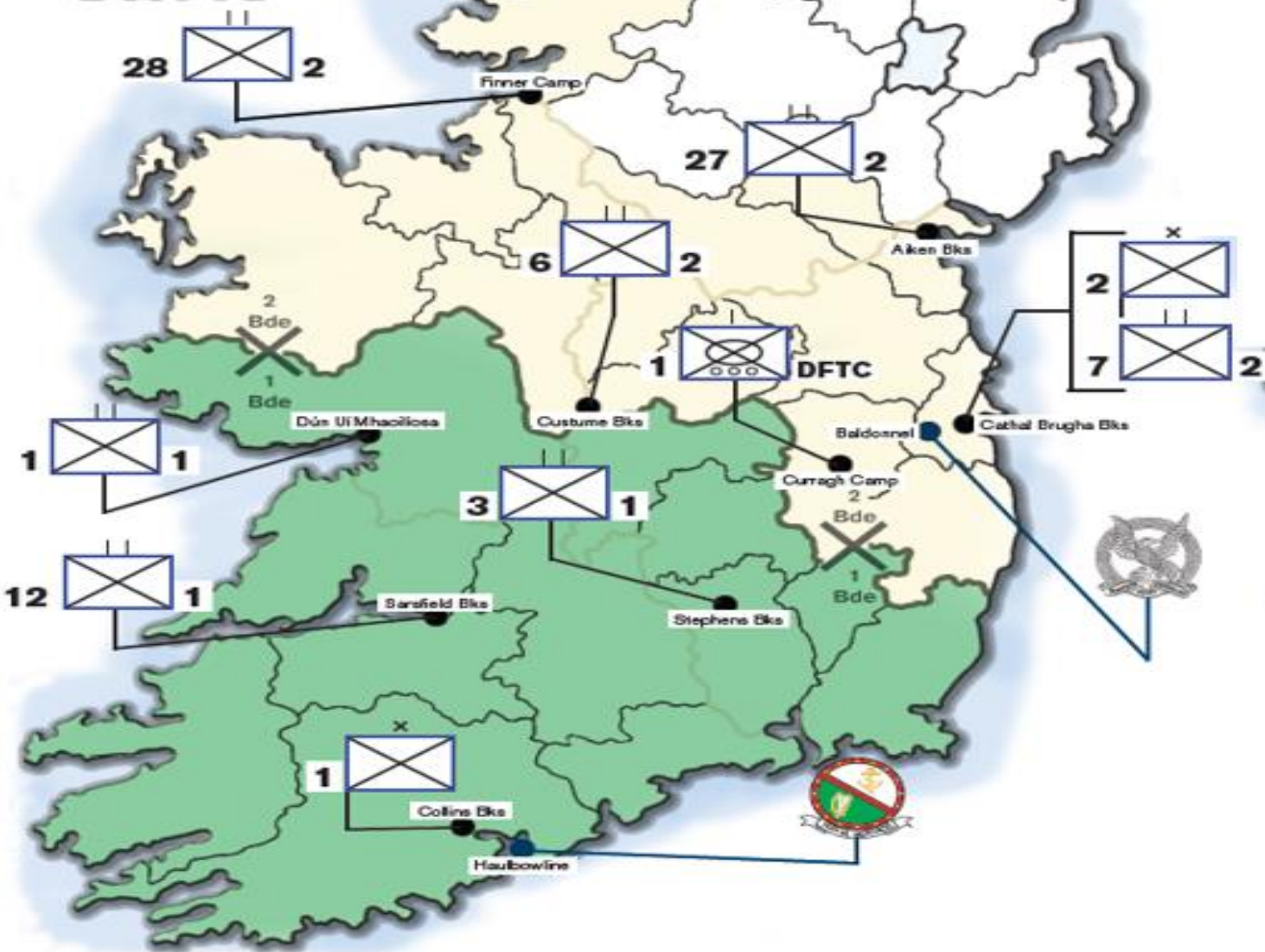

Defend | Protect | Support

## DF Disposition



PDF = 9,500  
 RES = 4,169



12 Missions

586



- > Military defence of the State (armed aggression)
- > Multi-national peace support and humanitarian relief operations
- > Aid the civil power (Garda Síochána)
- > Maritime security (Fishery Protection)
- > Joint Taskforce on Drugs Intentional
- > Aid to Civil Authority (major emergencies)
- > Ministerial air transport service (MATTS);
- > Ceremonial Services
- > Fulfil other tasks, supports to government depts. and agencies (contingency)

**Risk is a common factor**





## Public Sector

- Mullarkey Report (2002)
- Good Governance in the Public Sector 2014
- White Paper on Defence 2015
- Risk Management for Government Departments and Offices 2016
- ISO 31000 2009

## DF Guidance

- GRO H &S Risk Management 1/2010
- A.O. 02-2013 – COS RM Policy
- GRO DF Risk Management 04/2013
- Defence Forces Strategy Statement 2017-2020
- Brigade / Unit RM policies



- > Reflect Private Sector developments....
  1. Political risk context.
  2. Changing Domestic and International demands and responses.
  3. Risk language, methods and frameworks.



Óglaigh  
na hÉireann  
DEFENCE FORCES IRELAND

# STRATEGIC CONTEXT

Defend | Protect | Support



White Paper 15

STRATEGIC RISK REGISTER

SMC

Civil-Military Judgement



High-level Goal Strategic  
Dimensions



# Guiding Principles Strategic RM

- Informed by best governance and ISO 31000.
- Embed SRM within existing structures and processes.
- Based on best available information. Risk Management for Government Departments and Offices 2016
- SRM is organisationally inclusive.
- Strategic Risk assessments are informed by strategic business objectives.
- Operational and branch risk registers are aligned through the use of common terminology.



# BATTLE RHYTHM

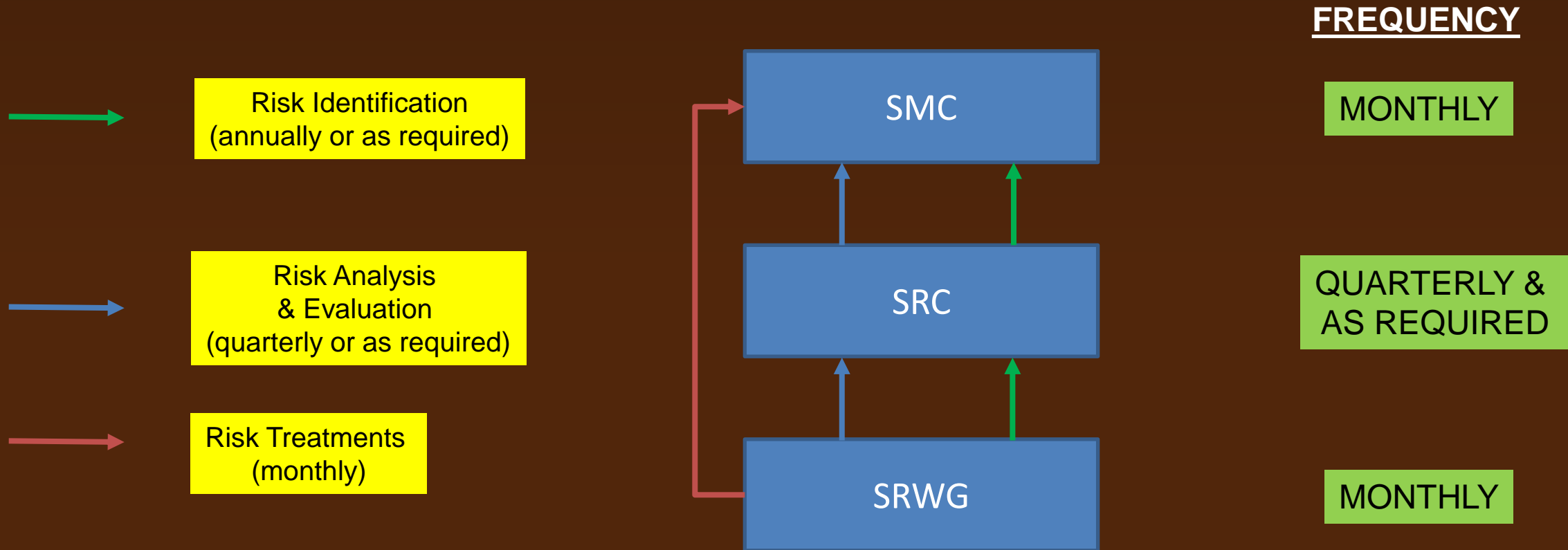



## Likelihood

1	Rare	Risk is unlikely to materialise. May occur but only in exceptional circumstances. Minimal chance of occurring in the next 5 years.
2	Low	Risk is possible, but not likely to materialise. Could occur but doubtful. Low chance of occurring in the next 5 years.
3	Medium	Risk is a strong possibility. Some indications that the risk will materialise. Up to 50% chance of occurring in the next 2 years.
4	High	Clear indications that risk is highly likely to materialise. Up to 75% chance of occurring in the next year.
5	Very high	Risk is imminent. Risk is almost certain to occur. Over 75% chance occurring in next year.



	Minor (1)	Limited (2)	Serious (3)	Substantial (4)	Catastrophic (5)
1. H&S					
2. Operations & Training					
3. Financial					
4. Inter Agency Stakeholders					
5. Functionality					
6. Compliance					
7. Reputation					

**Risk Categorisation = Likelihood X Impact**

0 – 8 **Green**; On target - No additional action required.

9 - 16 **Amber**; Problem identified - Action ongoing to resolve.  
*(or Potential problem - no action taken, carefully monitored).*

17-25 **Red**; Remedial action required immediately.



‘Risk Management is the term applied to a logical and systematic method of establishing the risk context, identifying, analysing, evaluating, treating, rectifying, monitoring and communicating risks associated with any activity, function, process or achievement of an objective in a way that will enable the Defence Forces to minimise losses and maximise opportunities’.

(COS, RM Guidance 2013)





- Purpose
  - ‘Afford protection to the DF...and the public service at large’
- Risk Management:
  - ‘Logical and systematic method...will enable the DF to minimise losses and maximise opportunities’
- Responsibilities
  - A COS (SRC)
  - DSPB (SRC & SRWG)



- > The Defence Forces continues to strive for an Effective Risk Management environment.
- > Uniqueness of military life.
- > Part and parcel of our daily jobs.
- > Continued collaboration with the Department of Defence.

**“...choice, not chance, determines your destiny...”**



Óglaigh  
na hÉireann  
DEFENCE FORCES

# QUESTIONS?

and | Protect | Support





# Closing Remarks

Dennis Keeley  
Chairperson EMII

Join @ [www.emii.ie](http://www.emii.ie)