

7-12-2014

IMPACTS OF DIURNALLY EXPOSED SLIME LAYER HYDROGEN SULFIDE CONCENTRATIONS IN SEWER ATMOSPHERE

Mark Holstad

Follow this and additional works at: https://digitalrepository.unm.edu/ce_etds

Recommended Citation

Holstad, Mark. "IMPACTS OF DIURNALLY EXPOSED SLIME LAYER HYDROGEN SULFIDE CONCENTRATIONS IN SEWER ATMOSPHERE." (2014). https://digitalrepository.unm.edu/ce_etds/94

This Thesis is brought to you for free and open access by the Engineering ETDs at UNM Digital Repository. It has been accepted for inclusion in Civil Engineering ETDs by an authorized administrator of UNM Digital Repository. For more information, please contact disc@unm.edu.

Mark S. Holstad

Candidate

Civil Engineering

Department

This thesis is approved, and it is acceptable in quality and form for publication:

Approved by the Thesis Committee:

Kerry Howe, Chairperson

Bruce Thomson

Andrew Schuler

**IMPACTS OF DIURNALLY
EXPOSED SLIME LAYER
HYDROGEN SULFIDE CONCENTRATIONS
IN SEWER ATMOSPHERE**

by

MARK S. HOLSTAD

**BACHELOR OF SCIENCE
CIVIL ENGINEERING
UNIVERSITY OF NEW MEXICO
DECEMBER 1975**

THESIS

**Submitted in Partial Fulfillment of the
Requirements for the Degree of**

Master of Science

Civil Engineering

The University of New Mexico

Albuquerque, New Mexico

May 2014

ACKNOWLEDGEMENTS

I returned to the University of New Mexico with great excitement. Through each class I gained insights and skills that I have and will continue to utilize. I thank each of my engineering professors, Dr. Andrew Schuler, Dr. Julie Coonrod, Dr. Kerry Howe, and Dr. Bruce Thomson, from whom I learned so much. I thank my Committee and especially my advisors, Dr. Thomson and Dr. Howe. Thank you for your attention, support, and guidance.

I thank the Water Authority for its support, both tangible and intangible.

I recognize Edward A. Lamb who provided the insights on a possible cause of diurnal [H₂S] variations and testing method concepts and assisted with the initial rounds of testing. I thank Dr. Jes Vollertsen and Dr. Asbjørn Nielsen for their assistance.

Thirty eight years ago. I started my career in wastewater engineering and I married the love of my life. These were two great things in one year. Cathy, you were always my favorite.

IMPACT OF EXPOSED SLIME LAYER ON HYDROGEN SULFIDE CONCENTRATIONS IN SEWER ATMOSPHERE

by

Mark S. Holstad, PE

B.S., Civil Engineering, University of New Mexico, 1975

ABSTRACT

Hydrogen sulfide (H_2S) is a major issue in wastewater collection systems. H_2S can cause rapid damage to wastewater infrastructure, affects the public's quality of life through odor issues and is a safety concern for sewer workers.

Relatively recent development and introduction of H_2S data loggers has shown that H_2S concentrations in the sewer headspace demonstrate a diurnal pattern that is not explained by current models. Odor complaints and toxicity are primarily a result of the peak concentration levels and may be more accurately predicted through a better understanding of the diurnal H_2S concentration patterns.

Biological slime layer grows in the submerged portion of sanitary sewer pipes and is the primary source of H_2S in the sewer atmosphere. The diurnal hydraulic cycle common to sanitary sewer systems results in the periodic exposure of a portion of the slime layer. It was hypothesized that the diurnally exposed slime layer impacts the sewer atmosphere concentration of H_2S . Utilizing laboratory style tests in a field sewer system showed that the slime layer, when exposed to the sewer atmosphere, will remove H_2S . This has not been previously demonstrated and helps explain the diurnal H_2S variation in the sewer atmosphere.

Table of Contents

List of Figures	vii
Introduction	1
Problem Statement.....	3
Thesis Objective	4
Literature Review	5
Overview	5
Models	8
Overview	8
Pomeroy and Parkhurst Equations	9
WATS Model	11
Submerged Slime Processes	12
Bulk Flow.....	12
Oxidation on Pipe Walls.....	13
H ₂ S Diurnal Pattern Studies.....	15
Diurnally Exposed Slime Layer	21
Distribution of Pipe Corrosion	23
Hypotheses	24
Methodology.....	25
Introduction	25
Samples.....	25
Test Chamber	26
OdaLog Data Logger.....	27
Calibration Gas.....	29
Data Processing.....	29
Slime Growing Location	29
Test Protocol	34
Slime Sample Testing	34
Sewage Sample Testing.....	38
Wet Chamber Testing	38
Dry Chamber Testing.....	39
Results.....	40

Sewage and Slime Tests – Prior to Adding Calibration Gas	40
Chamber Cap on Bucket.....	40
No H ₂ S Emission from Exposed Slime Layer.....	41
Test Results After Calibration Gas Added	41
Dry Chamber Testing / Uptake Due to Sensor	43
Wet Chamber Testing	46
Sewage Sample Testing.....	49
Slime Sample Testing	50
Maximum [H ₂ S] from Calibration Gas versus Measured Levels.....	53
Implication of Diurnally Exposed Slime Layer on [H ₂ S]	54
Conversion to Altitude	57
Summary and Conclusions.....	58
Summary.....	58
Methodology.....	58
Results.....	58
Implications to the Sewer Atmosphere Diurnal [H ₂ S].....	58
Limitations of Study	58
Not a Sewer.....	58
Removal Rate with Additional Exposure.....	59
Vary Time Exposed to Atmosphere Diurnally	59
Decreased Oxygen	59
Range of [H ₂ S]	59
Gas Mixing in the Test Chamber	59
Implications for Future Research.....	60
Address above Limitations.....	60
Slime Characteristics.....	60
Corrosion Patterns	60
Combined OdaLog & Flow Observations	61
Model Diurnal Increase in Pipe Surface Uptake	61
Conclusions	61
References	62

List of Figures

Figure 1 Major processes including pathways for sulfur cycle and associated problems in sewer networks (Yongsiri et al., 2003)	1
Figure 2 Diurnally Exposed Slime Layer	4
Figure 3 Process Occurring in Sewers Under Anaerobic Conditions (EPA 1974 from WERF 2007)	5
Figure 4 The Sewer Sulfide Cycle (WERF, 2007)	7
Figure 5 Reaction Pathways for Sulfur in Sewers (Jensen, 2009)	8
Figure 6 Major Processes Interacted with Hydrogen Sulfide Emission with Reference to Dissolved Oxygen Balance in Sewer Networks (Yongsiri et al. 2005)	10
Figure 7 Outline of the Integrated Sulfur Cycle and Carbon Cycle Processes in Sewers Included in the WATS Model Concept. The Water Flow, Gas Flow, and Ventilation Are Not Indicated (Nielsen et al., 2008a)	11
Figure 8 Box-plot of the Hydrogen Sulfide Removal Rates of Concrete, PVC and HDPE Reactors (Jensen, 2009; Nielsen et al. 2008b)	15
Figure 9 Measured and Simulated Diurnal Variation of Sewer Gas H ₂ S Content (Vollertsen et al., 2014)	17
Figure 10 Typical Hydraulic Diurnal Pattern (San Jacinto Manhole J21-142)	18
Figure 11 Typical [H ₂ S] Diurnal Pattern (Same Location).....	18
Figure 12 Flow Diurnal vs. H ₂ S Diurnal (Holstad, 2012)	19
Figure 13 Diurnal vs. Various Factors (Holstad, 2012)	19
Figure 14 Intermittently and Continuously Submerged Slime Areas of sewer Wall (Thistlethwayte 1972)	22
Figure 15 Hypothesis: H ₂ S Emission From Diurnally Exposed Slime Layer	23
Figure 16 Distribution of Corrosion in a Sewer (EPA 1985)	24
Figure 17 PVC Coupons Used for Thesis Testing.....	25
Figure 18 Test Chamber Elevation and Plan	26
Figure 19 OdaLog Set in Cap	27
Figure 20 Cap and OdaLog Ready to Place on Chamber with Sample.....	27
Figure 21 Bottom View of Cap with OdaLog.....	28
Figure 22 Sensor Schematic (City Technology)	28
Figure 23 PTF Plan View - Effluent Channel Lower Left.....	31
Figure 24 Section 3 Through PTF - Effluent Channel to Left –See Figure 23 for Cut	31
Figure 25 Section 2 Through PTF See Figure 23 for Cut.....	32
Figure 26 Gate Cover and Plate Over Effluent Channel.....	32
Figure 27 South Side of PTF - Looking Downstream Along Effluent Channel.....	33
Figure 28 PTF Channel Looking Downstream - Slide Gate on Right.....	33
Figure 29 Sample Hanging in Effluent Channel.....	34
Figure 30 Sample Before and After Hanging in Flow Eight Days	34
Figure 31 Test Sequence for Slime and Sewage Samples	35

Figure 32 Slime Sample Showing Accumulation on Braided Line before Cutting and Replacing with Nylon Line	37
Figure 33 Slime Sample after Tying with Nylon Line - Ready for Testing	37
Figure 34 Sampling Set-Up in PTF Blower Building.....	38
Figure 35 Office Set-Up for Dry Chamber Testing	39
Figure 36 Sample Slime Sample [H ₂ S] Results.....	40
Figure 37 Cap Placed on Sewage Bucket	41
Figure 38 Average Testing Results	42
Figure 39 Dry Chamber Testing Results	43
Figure 40 Dry Chamber Mass Consumption	45
Figure 41 Dry Chamber Reaction Rate.....	46
Figure 42 Wet Chamber Testing Results.....	47
Figure 43 Wet Chamber Reaction Rate.....	48
Figure 44 Sewage Sample Testing Results	49
Figure 45 Sewage Sample Reaction Rate.....	50
Figure 46 Slime Sample Testing Results.....	51
Figure 47 Slime Sample Reaction Rate	52
Figure 48 H ₂ S Removal Rate by Exposed Slime.....	53
Figure 49 Demonstrated H ₂ S Removal by Diurnally Exposed Slime Layer.....	54
Figure 50 Example of Diurnal Variation in H ₂ S Uptake by Pipe Material.....	56
Figure 51 Stir Bar against Chamber Wall	60

Introduction

Hydrogen sulfide (H_2S) commonly occurs in sanitary sewer systems and causes significant corrosion and odor complaints. It is also very toxic and presents a threat to employees who must enter confined spaces. (Unless otherwise noted, $[H_2S]$ refers to the gas phase concentration.) Figure 1 shows the pathway for the sulfur cycle in a sewer network (Yongsiri et al., 2003). H_2S in sewers has been extensively studied due to its great financial, safety and quality-of-life impacts.

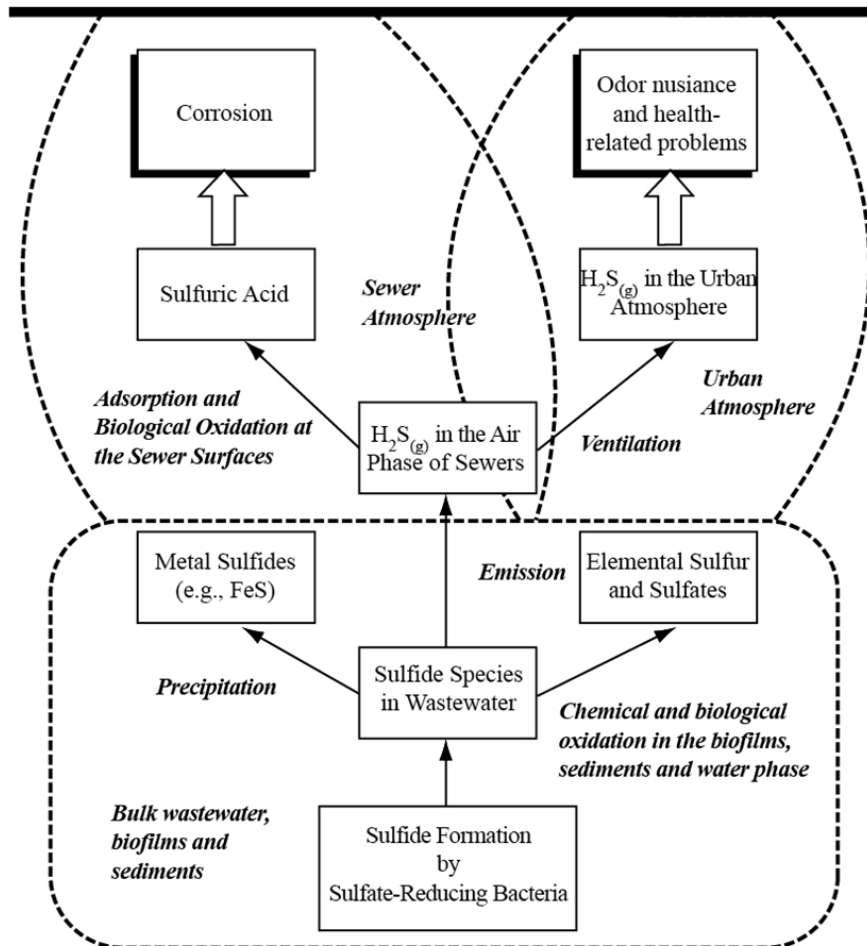

Figure 1 Major processes including pathways for sulfur cycle and associated problems in sewer networks (Yongsiri et al., 2003)

The concentration of H₂S in the sewer atmosphere, i.e., [H₂S], is based on the volumetric fraction of H₂S in the sewer atmosphere. H₂S enters the sewer atmosphere by emission from the bulk sewage and is primarily removed either by oxidation on the exposed pipe surface or by advection to the urban atmosphere. Each of these factors, emission rate, oxidation rate, advection rate, and volume, are continuously changing through the diurnal cycle. Sewers diurnal hydraulic flow patterns vary predictably by time of day, the day of the week, season and holiday. In a somewhat light-hearted manner, Kevin L. Enfinger and Patrick L. Stevens have developed Sewer Sociology which is defined as “the science of society, social institutions, and social relationships viewed through the eyes of a sewer” (Enfinger and Stevens, 2006). As may be expected, the [H₂S] also exhibits a diurnal pattern (Haan, 2009; Vollertsen et al., 2014). However, while the emission and oxidation inputs to the [H₂S] have been significantly examined and explained in the Literature, and ventilation (advection) has been studied with significant room for growth, and the atmosphere volume is a direct application of the depth of flow, the [H₂S] diurnal pattern has not been adequately addressed. In fact, portions of the [H₂S] diurnal pattern are contrary to expectations based on the current understanding. OdaLog™ data loggers are extensively utilized to monitor [H₂S] in sewer systems. The North American OdaLog distributor states that new clients are often surprised by the [H₂S] diurnal patterns occurring in sewers (Lindy Eppinger, personal communication, 2011). The author, when first presented an OdaLog report, directed the technician to correct the time setting because the report was clearly incorrect. However the data was correct and what was demonstrated as incorrect was the author’s belief that

the primary [H₂S] variable at a location was H₂S off-gassing due to turbulence proportional to the flow velocity.

A better understanding of the [H₂S] diurnal pattern has direct application to the toxicity and odor issues. The diurnal peaks are the design criteria against which odor mitigations must be designed. The author, responsible for addressing and resolving public odor complaints in the Albuquerque system, has experienced that no credit is given for daily periods with non-detectable odors if followed by obnoxious episodes. Nielsen et al. (2008a, p. 24) make this point stating: “For the evaluation of odor- and toxicity-related problems, the extreme values are likely to be more important, as even short periods of strong odor are often sufficient to instigate a problem. Inherently, it is more difficult to predict odor- and toxicity-related problems than corrosion rates.”

Problem Statement

The sulfur cycle is well understood (WERF, 2007). The factors that cause H₂S to emit more quickly from the bulk wastewater, such as turbulence, pH, and high sulfide concentrations in the bulk wastewater, are widely understood (EPA, 1974; EPA, 1985; ASCE, 1985; WERF, 2007). Factors that cause increased sulfide levels in the bulk wastewater include: slow velocities, high strength wastewater, high temperatures, debris buildups, etc. (EPA, 1974; EPA, 1985; ASCE, 1989; WERF, 2007). The concentration of H₂S in the sewer atmosphere is the result of a myriad of factors existing in a very complex relationship (Vollertsen et al., 2014). These existing understandings are adequate for practitioners to identify the cause and resolution of odor problems occurring at a specific location – typically very high sulfides and / or turbulence (WERF 2007) – and why [H₂S] varies seasonally – variation in biological activity with sewage

temperature (Holstad 2012). Similarly well understood are the impacts of organic loading, pH, etc. (EPA, 1984; WERF, 2007). However, there is little current understanding of diurnal variations.

The $[H_2S]$ diurnal may be expected to relate to the diurnal flow, i.e. hydraulic, patterns (Haan, 2009). This was the expectation of the author and is the likely the reason for the previously described surprise experienced by new OdaLog clients. However, Holstad (2012) examined a set of hydraulic parameters at a specific location and found that none adequately explained the $[H_2S]$ diurnal pattern. Holstad (2012) did identify the possible impact of the diurnally exposed slime layer on the $[H_2S]$.

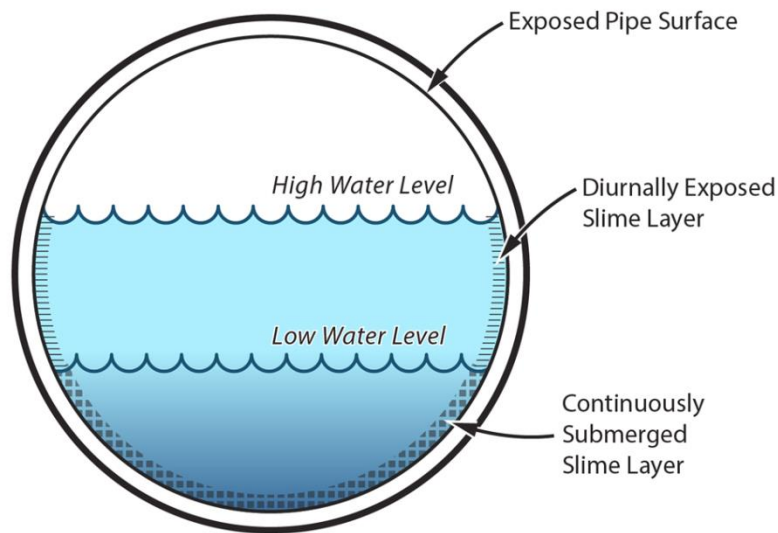

Figure 2 Diurnally Exposed Slime Layer

Thesis Objective

Previous investigations have given little attention to the diurnally exposed slime layer (Figure 2). As the water level rises and falls organisms in this zone are exposed to alternating periods of submergence then exposure to the atmosphere. The objective of the research described here was to test the impact of the exposed slime layer on $[H_2S]$ and

determine the role of this slime layer in diurnal [H₂S] in the atmosphere of the sewer environment.

Literature Review

Overview

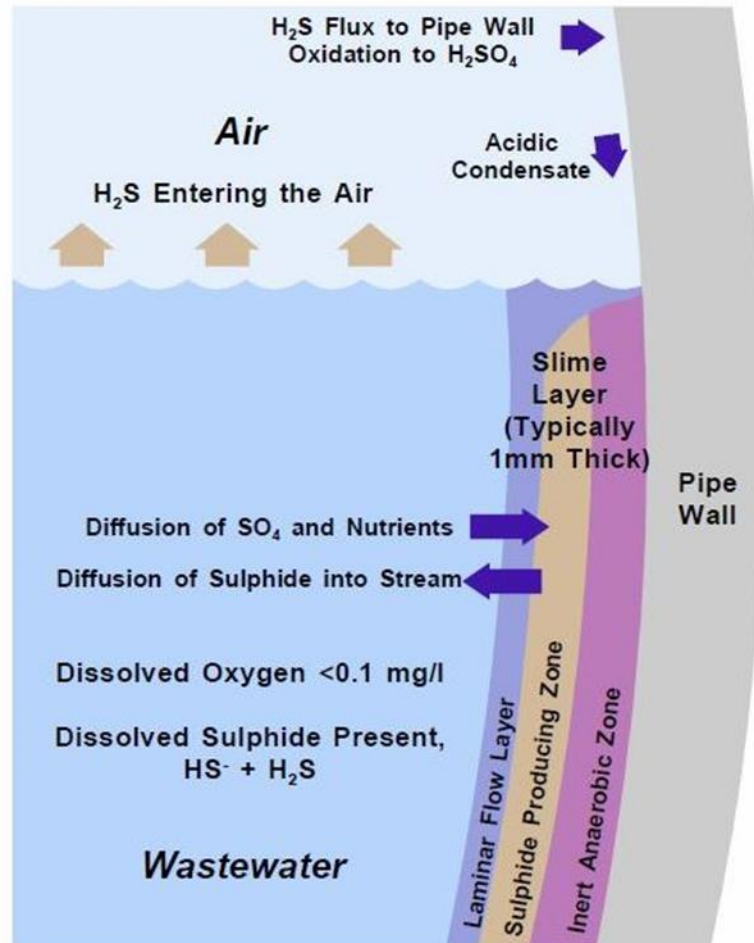

Figure 3 Process Occurring in Sewers Under Anaerobic Conditions
(EPA 1974 from WERF 2007)

Figures 1, 4 and 5 provide graphic representations of the sulfur cycle and sulfide transformations. The sewer sulfur cycle has been studied extensively and is understood as follows: Slime layer bacteria in the sewer are attached to the pipe wall and the “wetted perimeter” portion of associated with bottom sediment depositions, produce hydrogen

sulfide through anaerobic sulfate reduction. Sulfides (H_2S , HS^- and S^{2-}) from this reaction enter the wastewater (Hvitved-Jacobsen, 2002). The hydrogen sulfide dissociates to H_2S , HS^- and S^{2-} with the speciation dependent on the pH; a portion of the H_2S in the bulk flow emits to the sewer atmosphere and an instantaneous adjustment occurs in the liquid phase sulfide species (EPA 1985, p. 6). The H_2S adsorbs to the moist pipe wall adjacent to the sewer atmosphere and is oxidized to sulfuric acid (H_2SO_4) by Thiobacillus bacteria (WERF 2007, pp. 2-22). The sulfuric acid reacts with concrete or metal surfaces or eventually drains to the bulk liquid and is neutralized to sulfate (SO_4^{2-}), with no net change in pH from the generation of acid from H_2S in sewers (WERF 2007, p. 2-22). Where severe corrosion and / or odor issues are to be addressed, typical practice is: 1) Estimate the sulfide transitions through the flow in the sewer; 2) Examine turbulence, either throughout the pipe or localized, that will drive off sulfides to the sewer atmosphere; 3) Where odor is a concern, evaluate ventilation, specifically over-pressurization, that may expel the sewer atmosphere to the urban atmosphere. E.g., WERF (2007, p. 2-25) provides two strategies for controlling the emission of hydrogen sulfide to the sewer atmosphere; either prevent turbulence or reduce the concentration of hydrogen sulfide in the liquid phase.

In accordance with Henry's Law, once the H_2S is emitted across the liquid-air interface, for practical purposes the H_2S does not reenter the wastewater (Nielsen et al. 2008b, p. 4209). Liquid phase models are available that follow the wastewater's transit through the sewer, with the sulfides being generated in the slime layer, diffusing to the bulk wastewater, and ultimately emitting to the sewer atmosphere. A model predicts the sulfide concentration at the downstream end of a sewer segment or reach, after reduction

by either being emitted to the sewer atmosphere or being oxidized due to reaeration. This predicted sulfide concentration is then the input for the next reach as the liquid phase model continues downstream. Recent studies have quantified the rate of biological consumption of sewer atmosphere H_2S as a function of the H_2S concentration (Nielsen, 2008b; Jensen, 2009). Ventilation of sewers, in which the sewer atmosphere is carried through the sewer and exchanged with the urban atmosphere, is recognized as a critical issue in odor control and the conceptual factors such as wastewater drag are generally agreed upon. However WERF (2007) states “Diurnal variances in flow make it difficult to obtain consistent and repeatable data.”

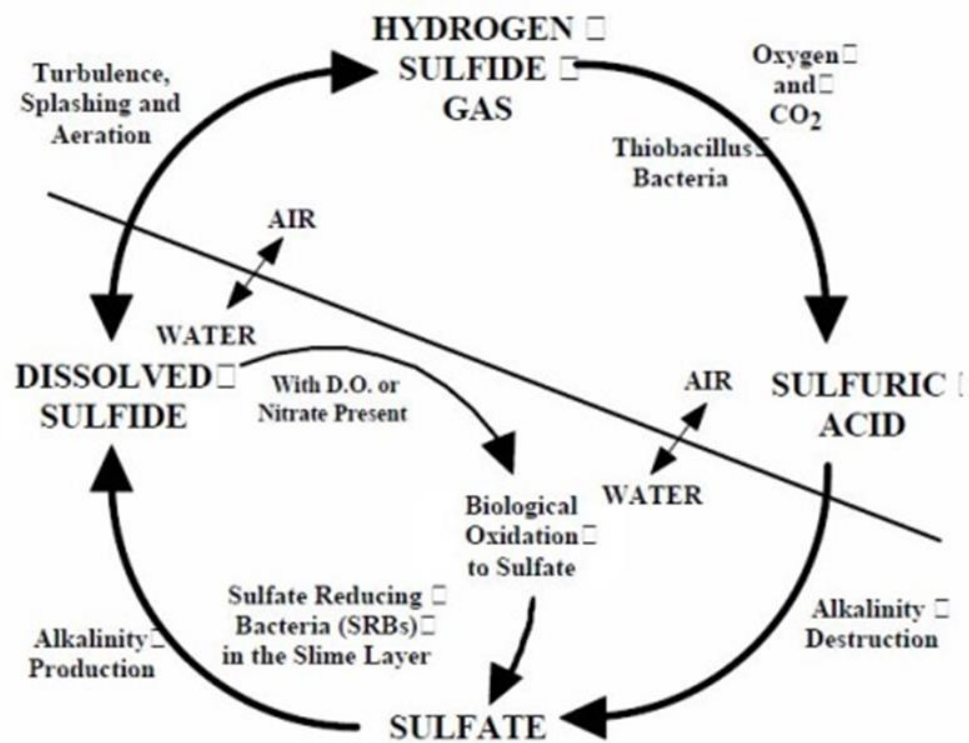

Figure 4 The Sewer Sulfide Cycle (WERF, 2007)

Figure 5 shows the sewer sulfide cycle with further description of the sulfur cycle within the slime layer (right), in the bulk flow (center) including sulfide binding by metals, and sulfide transformation and resulting corrosion in concrete pipe (left).

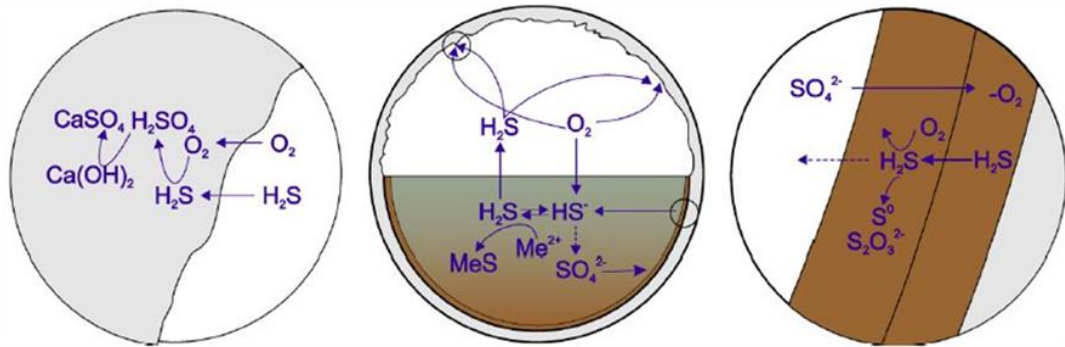

Figure 5 Reaction Pathways for Sulfur in Sewers (Jensen, 2009)

Models

Overview

As a part of WERF (2007, p. 5-1), a systematic review was performed of models for odor and corrosion involving the following biological, chemical, and physical processes: liquid phase sulfide generation; liquid-to-vapor H_2S mass transfer; natural liquid phase chemical and biological oxidation of sulfides; dissolved oxygen impacts on sulfide generation; liquid and vapor phase bulk transport of sulfides and H_2S respectively; vapor phase H_2S -induced concrete corrosion. Six models were cited, all of which were steady state. “As such none of them can be used to track the generation and fate of sulfide over the course of transient events such as diurnal flow variation” (WERF 2007, p. 5-3). Diurnal modeling by Vollertsen et al. (2014) is discussed below in which it is stated “Sewer process models are, though, still research tools on an experimental stage and not mature and commercially available like for example hydrodynamic sewer network models or models for simulating wastewater treatment process.”

Pomeroy and Parkhurst Equations

WEF (2004, p. 135) states: Among the most widely used predictive equations are those developed by Pomeroy and Parkhurst (EPA 1985, p. 20). WEF (2004, p. 138) states, the equation for partially full gravity sewers is:

$$S_2 = S_{\text{lim}} - \frac{(S_{\text{lim}} - S_1)}{\log^{-1} \left[\frac{m(su)^{\frac{3}{8}} t}{2.31d_m} \right]}$$

Where

S_2 = predicted sulfide concentration at time t_2 (mg/L);

S_1 = sulfide concentration at time t_1 (mg/L);

S_{lim} = limiting sulfide concentration (mg/L) = (M/m);
= (M³/m) EBOD (su)^{-3/8} (P/b)

EBOD = effective biochemical oxygen demand (BOD), BOD = BOD X 1.07^(T-20)
(mg/L)

T = wastewater temperature (°C)

M³ = effective sulfide flux coefficient in gravity sewers (m/h);

m = empirical coefficient for sulfide loss;

s = slope (m/m);

u = stream velocity (m/s);

t = flow time in a given sewer reach with constantly slope, diameter, and flow (h);

d_m = mean hydraulic depth, equal to area of flow divided by surface width (m);

P = wetted perimeter (m); and

b = width of wastewater stream at surface (m).

Lahav et al. (2004, p. 1383) explains the equation consists of two terms: the first predicts the rate of sulfide generation in the sewer and the second represents the rate of sulfide elimination from the liquid phase, i.e., the combined effect of biological sulfide oxidation, sulfide stripping, and indirectly, the effect of natural ventilation on the concentration of sulfide in the gas phase of the sewer. Figure 6 demonstrates a portion of this discussion. Numerous studies have found that most sulfide emitted to the bulk wastewater is oxidized in a gravity sewer rather than being emitted as H_2S to the sewer atmosphere, e.g., Nielsen et al. (2008a, p. 23) and Nielsen et al. (2008b, p. 4210).

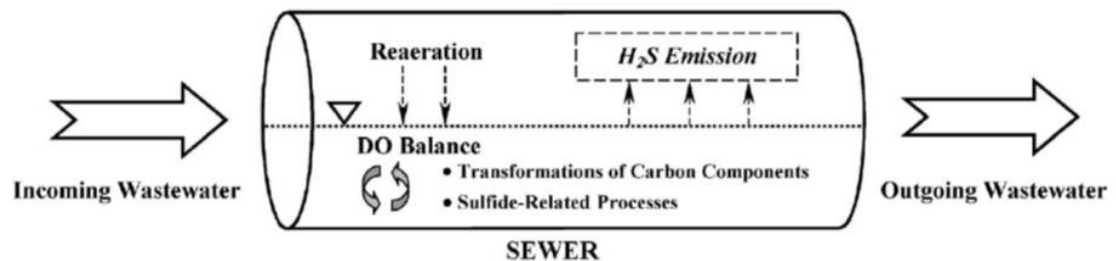

Figure 6 Major Processes Interacted with Hydrogen Sulfide Emission with Reference to Dissolved Oxygen Balance in Sewer Networks (Yongsiri et al. 2005)

Æsoy et al. (2002, p. 138) states “In practice Pomeroy’s equation has not been found to be very accurate. When applied to the Central Trunk System in Sacramento County (USA), the relationship under predicted the actual corrosion rates by a factor of 2-5 (ASCE 1989).” This appears to be a concern related to the $[H_2S]$ rather than the predictive quality of the liquid phase sulfide concentration.

A statistical analysis of Pomeroy-Parkhurst model developed for the Water Authority system demonstrated that the model is a statistically significant predictor of the field-measured liquid phase sulfides (Holstad, 2010).

WATS Model

Nielsen et al. (2008a, p. 18) states: “The WATS (Wastewater Aerobic-anaerobic Transformations in Sewers) model concept is outlined in Figure 7. The WATS model concept links the sulfur cycle to dynamic modeling of the in-sewer carbon cycle in terms of mass transport, transformations and interfacial exchanges that occur in the water phase, the biofilms and the gas phase. For simulating what is considered the main in-sewer processes, the model includes a number of model components (boxes) and corresponding transformation processes (arrows). Each process is described by a rate equation and a stoichiometric constant resulting in a large number of coupled differential equations.”

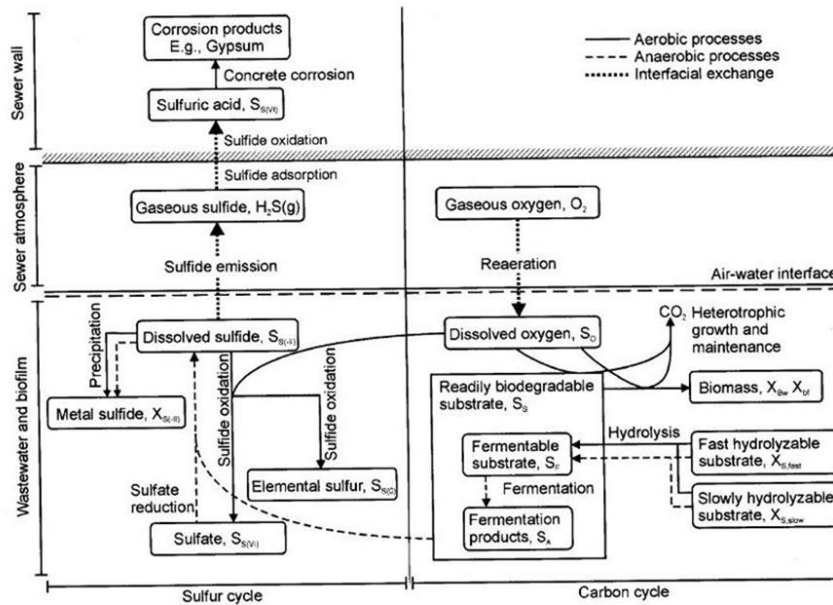

Figure 7 Outline of the Integrated Sulfur Cycle and Carbon Cycle Processes in Sewers Included in the WATS Model Concept. The Water Flow, Gas Flow, and Ventilation Are Not Indicated (Nielsen et al., 2008a)

Regarding WATS, Vollertsen et al. (2014) states “This concept also constitutes the starting point of two other sewer process models at present being developed for studies of in-sewer process.”

Submerged Slime Processes

EPA (1974, p. 3-2) states “The place where strictly anaerobic conditions can develop is in the slime layer that forms on the submerged pipe wall. This layer is a matrix of filamentous microbes and gelatinous material (zooglae) embedding various smaller bacteria.” It is noted that “slime” is also the term typically used by Thistlethwayte (1972), EPA (1985), ASCE (1989), WERF (2007) while “biofilm” is used by Nielsen, Vollertsen and others.

Referencing Figure 5, right hand side, Jensen (2009, p. 13-14) stated that sulfide generation is “primarily associated with sewer biofilms and sediments as the bacteria are slow growing and hence washed out of the bulk water phase” and later “Sulfide can be produced in the anaerobic parts of biofilms that is partly penetrated by oxygen. In this case, oxidation of sulfide takes place in the parts of the biofilms containing oxygen (or nitrate, leading to an internal cycle of sulfur within the biofilms.”

Nielsen et al. (2005b, p. 4124) describes investigations in which biofilm sulfide oxidation was found to be equally important as the oxidation occurring in the bulk water.

Bulk Flow

Jensen (2009, p. 14) states: “When sulfide is present in aerobic wastewater or anoxic wastewater, sulfide is removed from the wastewater by oxidation (Figure 5, middle). The oxidation of sulfide with oxygen occurs both chemically and biologically (Nielsen et al., 2006). The main products in the chemical sulfide oxidation are thiosulfate and sulfate, whereas elemental sulfur is formed in the biological oxidation (Nielsen et al., 2006).”

Oxidation on Pipe Walls

Matos and De Sousa (1992, p. 918) described numerous experiments in which concentrations of hydrogen sulfide in wastewater and in sewer atmospheres were determined simultaneously at states “when calculations are made of the amount of gas which would be in the air if it were in equilibrium with the liquid phase, it was found that the amount actually present only corresponds generally to 2 to 20 percent of the equilibrium concentration. This indicates a rapid removal of hydrogen sulfide from the sewer atmosphere by oxidation on the pipe walls.”

Based on a controlled laboratory study replicating different pipe materials to be utilized on a gravity sewer downstream of a force main, Nielsen (2008b, p. 4213) stated about the sewer atmosphere: “The use of plastic pipes results in hydrogen sulfide gas concentrations that are approximately 10 times higher than in the concrete sewer. The steady state concentrations in the concrete pipe are generally below 5% of the theoretical equilibrium concentration calculated from Henry’s law, whereas the hydrogen sulfide concentrations in the plastic pipes are between 10 and 75% of the equilibrium value. Despite the big difference in the steady state hydrogen sulfide concentration, the oxidation rate on the concrete pipes was in this example higher than that on the plastic pipe only by a factor 3. This illustrates that the air-water mass transfer is typically the limiting process under normal flow conditions in sewers. Considering potential odor and toxicity problems, it is evident the use of plastic pipe will significantly enhance the risk of problems.”

Nielsen et al. (2008b, p. 4207) states: “On concrete surfaces, sulfuric acid will react with the alkaline components of the concrete, thereby neutralizing the acid. The plastic surfaces are inert and will not neutralize the acid. It is therefore likely that the pH

will eventually become inhibitory for the sulfide oxidizing bacteria, thereby reducing the rate of sulfide oxidation. This will inevitably lead to higher sulfide concentrations on the pipe surface, which in turn will reduce the adsorption rate and result in higher hydrogen sulfide concentrations in the sewer atmosphere and an increased odor potential.”

Nielsen et al. (2005a, p. 202) states: “Hydrogen sulfide present in the sewer atmosphere may be adsorbed in the thin film of water that normally covers the sewer walls or it may be emitted to the urban atmosphere due to ventilation, potentially resulting in odor nuisances. Hydrogen sulfide that is adsorbed on the surface of the sewer walls is in part oxidized biologically to sulfuric acid by the action of a group of acidophilic bacteria of genus *Thiobacillus*.”

Jensen (2009, p. 20-21) states about the biofilm on the exposed pipe surface: “Compared to the release rate of hydrogen sulfide from the sewer bulk water to the sewer atmosphere, the removal rates of hydrogen sulfide on the concrete surface were fast. The immediate consequence of this is that the hydrogen sulfide release rates controls the corrosion rate (Vollertsen et al., 2008).” “The effect of the pipe material on the removal of hydrogen sulfide from the sewer atmosphere was investigated by comparing r_{10} , r_{100} and r_{1000} for the three types of reactors. The removal rates on the concrete surfaces were approximately two orders of magnitude higher than those of the plastic surfaces, whereas the difference between the two types of plastic was not significant (Nielsen et al., 2008b).” See Figure 8 in r_{10} , r_{100} and r_{1000} re the removal rates at $[H_2S]$ equal to 10, 100 and 1000 ppm respectively.

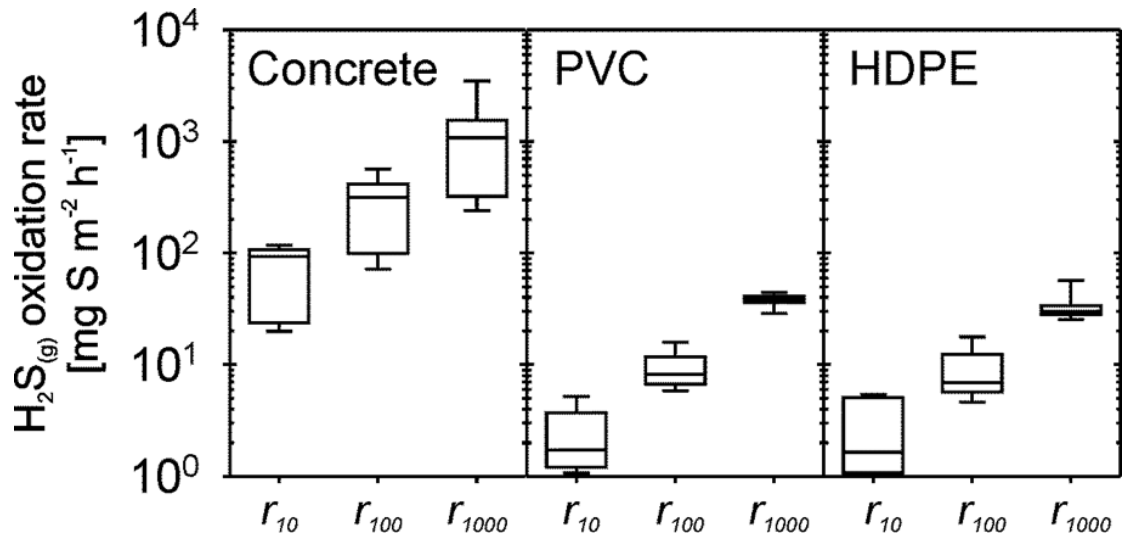

Figure 8 Box-plot of the Hydrogen Sulfide Removal Rates of Concrete, PVC and HDPE Reactors (Jensen, 2009; Nielsen et al. 2008b)

H₂S Diurnal Pattern Studies

The literature contains little analysis of diurnal sanitary sewer H₂S levels. EPA (1985, p. 26) states that sulfide levels vary with diurnal flow rates. This comment appears to be relative to the liquid phase sulfides rather than the gas phase [H₂S]. Haan (2009) proposes that diurnal variations in the detention time, i.e., the time the bulk wastewater has been in the sewer, may be the cause of diurnal H₂S variations. As described below Holstad (2012) examined detention time and rejected a correlation to diurnal patterns. Nielsen et al. (2008a, p. 22) examined a gravity sewer and states that “temporal dynamics of the measured sulfide concentrations could not be explained by variations of the anaerobic residence time and most likely were related to short-term variations of the wastewater biodegradability.” Nielsen et al. noted that to their knowledge no studies on short-term variations of sulfide concentrations in wastewater from sewers had previously been published. Because this study involved only short time periods, it did not address diurnal patterns.

Vollertsen et al. (2014) have recently utilized the WATS sewer process concept to examine the San Francisco Bayside drainage area. Because processes in sewers are highly variable in time and space a stochastic approach for modelling was utilized. The wastewater was assigned a diurnal pattern of COD (chemical oxygen demand) concentration as wastewater strength is known to vary over the day. Figure 9 shows the daily variations in measured sewer atmosphere concentration of H₂S gas for 4 of the sites. Vollertsen et al. found a tendency towards diurnal variation when looking at the average behavior over many days and stated that the simulations of the diurnal variations show that the general level of H₂S gas can be reproduced reasonably well by the model, although the measured variation over the day was mostly larger than the simulated variation. Vollertsen stated the statistical trend towards a diurnal variation in H₂S gas levels is most likely due to a similar trend in dissolved sulfide in the wastewater. However, the wastewater sulfide measurements did not show diurnal tendencies, with the explanation that “this might be due to a masking hereof by a combined effect of large natural variability and the number of gas measurements being many times larger than the number of wastewater measurements.”

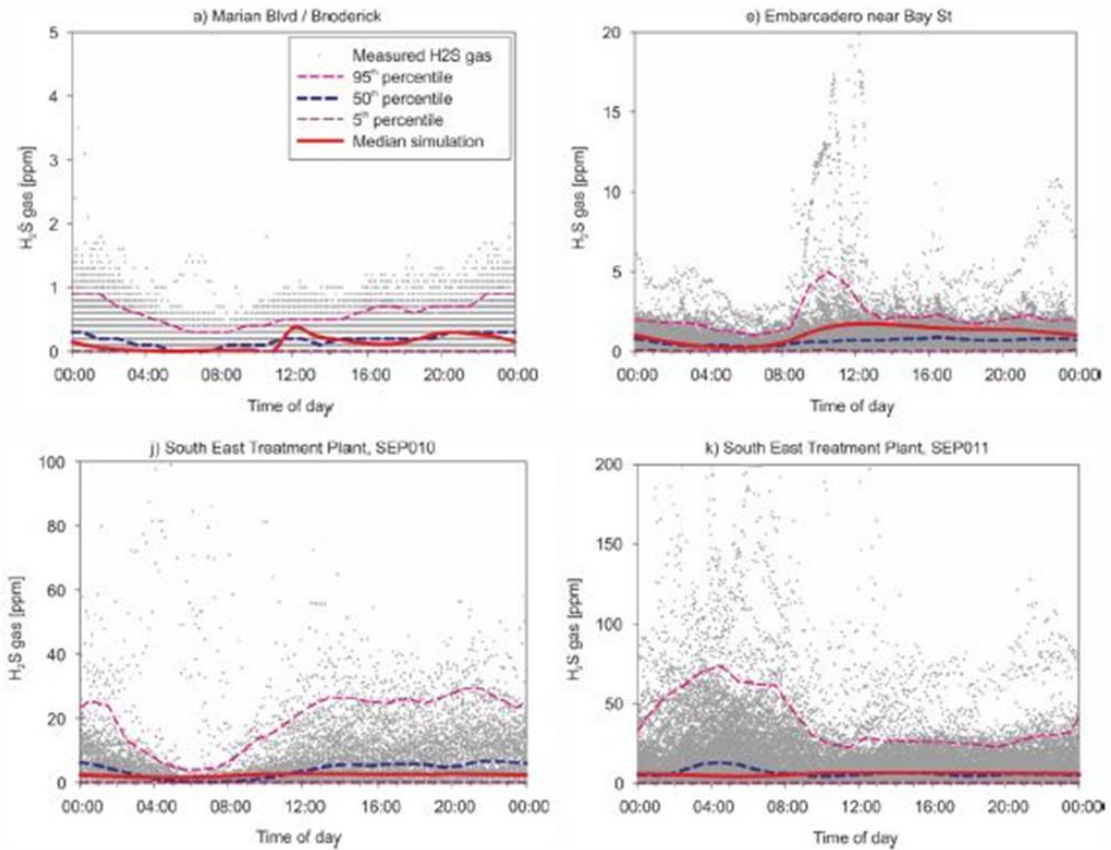

Figure 9 Measured and Simulated Diurnal Variation of Sewer Gas H₂S Content (Vollertsen et al., 2014)

Holstad (2012) compared several hydraulic diurnal variables in relation to the [H₂S] diurnal. Detailed hydraulic and [H₂S] data were obtained at the same manhole to compare the diurnal patterns. Based on reviews by experts such as Patrick Stevens, Mark Smith, Ed Lamb, US Peroxide, and Siemens (author's communications), the Water Authority system hydraulic and [H₂S] patterns are typical of those seen in other systems. Measured at the same manhole, the hydraulic data, i.e., depth, flow rate and velocity, are shown in Figure 10 and the [H₂S] data is shown in Figure 11. Diurnal patterns are clearly seen in each graph.

ADS Environmental Services

Pipe Height: 17.75

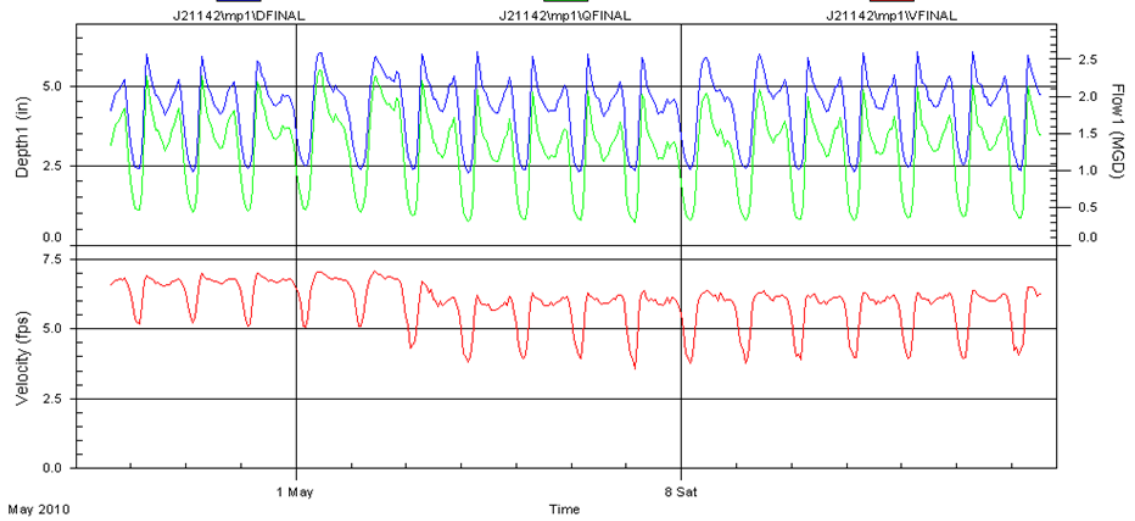

Figure 10 Typical Hydraulic Diurnal Pattern (San Jacinto Manhole J21-142)

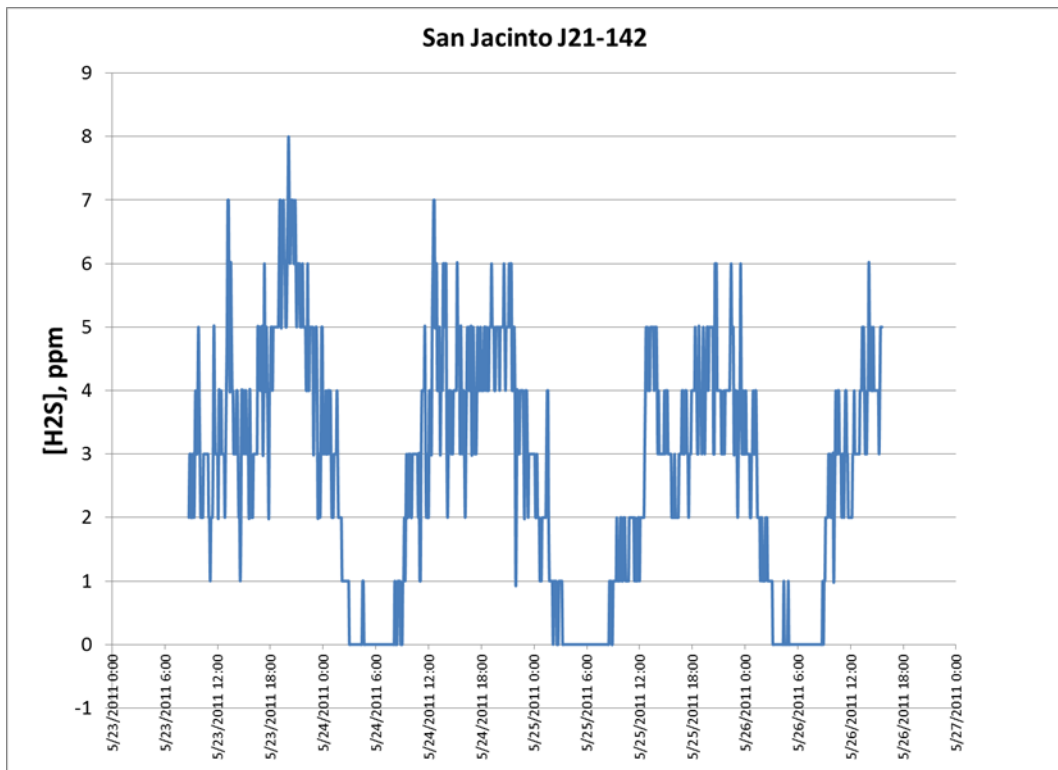

Figure 11 Typical [H₂S] Diurnal Pattern (Same Location)

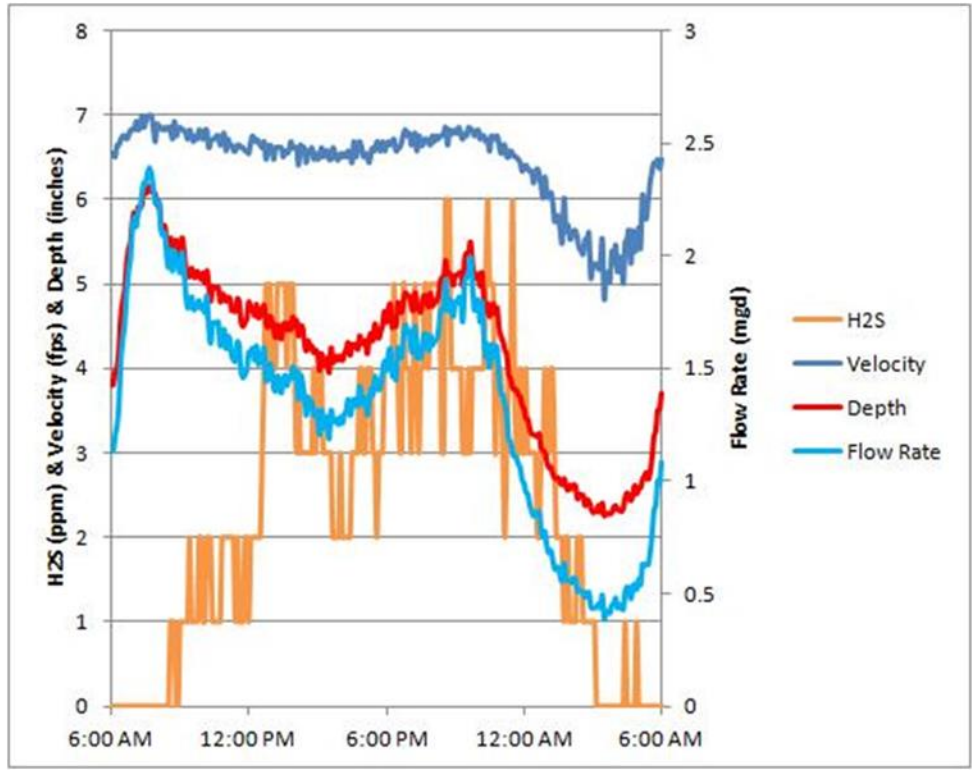

Figure 12 Flow Diurnal vs. H₂S Diurnal (Holstad, 2012)

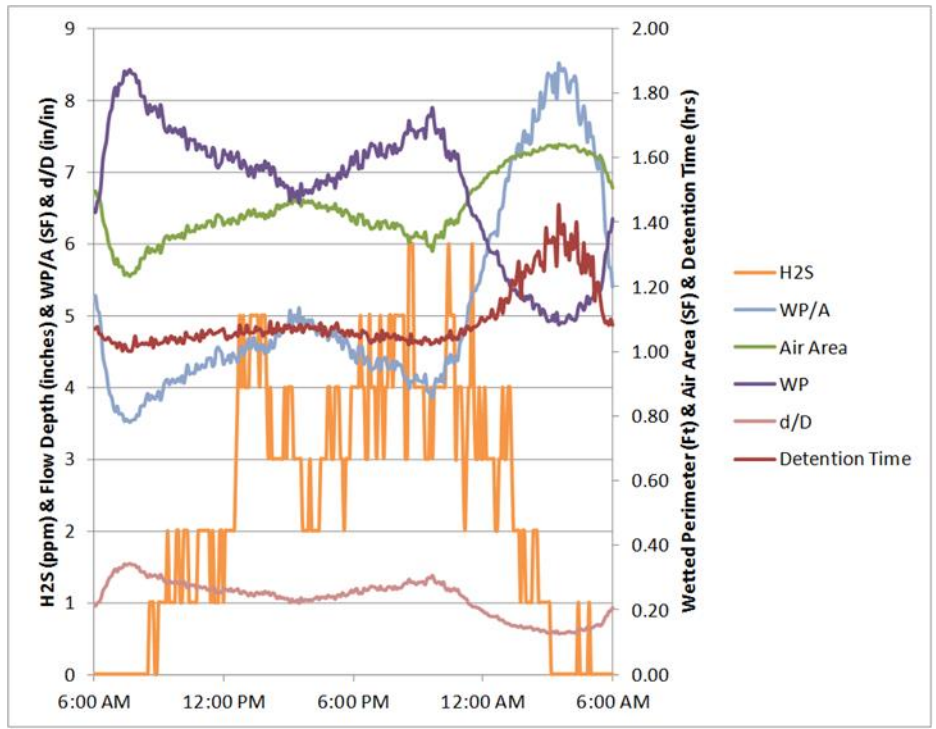

Figure 13 Diurnal vs. Various Factors (Holstad, 2012)

Figure 12 shows the hydraulic monitoring versus the measured $[H_2S]$ for a single 24-hour period. Figure 13 overlays computed variables that were thought to relate to increased H_2S emission. To examine the correlation between each of these factors, the day was broken into time periods in which the $[H_2S]$ was increasing, decreasing, or remaining constant and the variation of various factors were added. The parameters compared by Holstad (2012) and the reasons were as follow:

1. H_2S in the bulk liquid flow emits across the air-water interface to the sewer atmosphere. The emission rate increases when the concentration of sulfide increases in the bulk liquid flow. (Many sources, e.g. EPA (1985).)
2. Because EPA (1985, p. 20) and Nielsen et al. (2008a, p. 20) project the H_2S generation rate is proportional to the amount of slime area and therefore the wetted perimeter, a simple approach to estimate the concentration of sulfides is to compare the slime area to the bulk flow volume. The wetted perimeter, WP, versus the flow area, A, i.e. WP/A , is equivalent. WP/A is compared to the $[H_2S]$ in Figure 13.
3. Yongsiri et al. (2004a) states the emission process is regarded as a key process leading to problems pertaining to H_2S in sewer networks and knowledge of the H_2S emission is stated as still limited. Yongsiri (2004b, p. 83) concluded the Froude number is the correct dimensionless parameter to use and the Froude number was adopted to scale the force (i.e., the turbulence level), and further, turbulence in the water phase was the only major factor disturbing the air-water interface. Therefore, it can be expected that the emission rate is increased with

greater sewage turbulence which can be related to sewage velocity or Froude number. The velocity is compared to the $[H_2S]$ in Figure 13.

4. The volume of the sewer atmosphere changes diurnally. The sewer atmosphere volume decreases as the flow depth rises resulting in H_2S being discharged to the urban atmosphere while the $[H_2S]$ does not change. Conversely the sewer atmosphere volume increases as the flow depth drops, drawing in fresh air and reducing the $[H_2S]$. The Air Area is compared to the $[H_2S]$ in Figure 13.
5. As anaerobic detention time increases in a sewer flow, the sulfide levels increase (EPA, 1985; Haan, 2009). Detention time is compared to $[H_2S]$ in Figure 13. Holstad found no hydraulic variable that correlated throughout the diurnal $[H_2S]$ pattern.

Diurnally Exposed Slime Layer

Thistlethwayte (1972, p. 12 & 18) recognized the impact of the diurnal rise and fall of the wastewater level as it relates to the slime layer emitting H_2S to the bulk wastewater and proposed that the intermittently submerged surface emits less H_2S to the bulk wastewater than the continuously submerged slime layer (Figure 14).

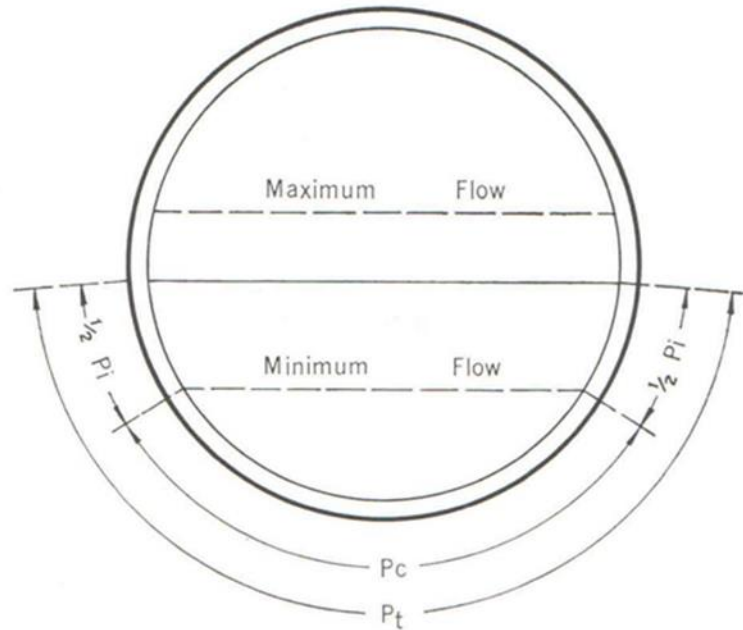

Figure 14 Intermittently and Continuously Submerged Slime Areas of sewer Wall (Thistlethwayte 1972)

Holstad (2012) proposed that the slime layer, when exposed, will emit directly to the sewer atmosphere (Figure 15). The study described in this thesis was originally intended to provide a controlled laboratory study to further validate the direct emission concept. It is noted that the direct emission hypothesis is not supported by this research.

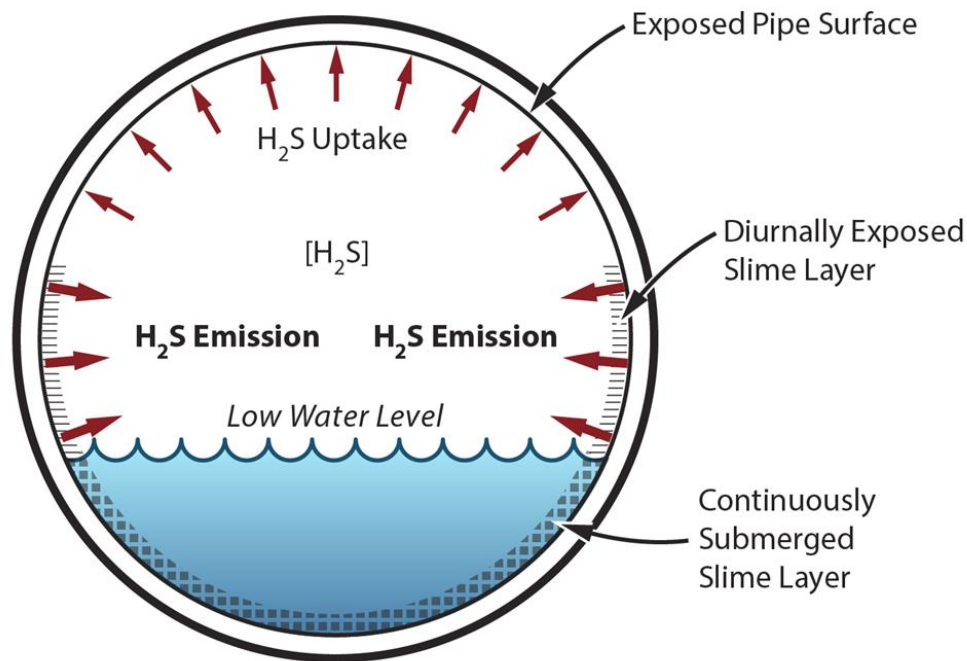

Figure 15 Hypothesis: H₂S Emission From Diurnally Exposed Slime Layer

Distribution of Pipe Corrosion

Corrosion of concrete pipe at the waterline is often severe. The EPA (1985, p. 18) explanation is that the acid forms on the wall, migrates to the bulk wastewater, where the intermittent washing of the pipe wall cleans away the pasty decomposition products of concrete. This exposes new concrete, which is subject to rapid attack by the acid. The resulting distribution of corrosion in the interior of a concrete sewer is shown in Figure 16. EPA (1985) states that corrosion of the pipe wall is not uniform due to several factors including air currents as shown in Figure 16. However, Mori et al. (1992, p. 31) observed increased corrosion immediately above the water level in field sewers and laboratory test samples and found the area just above the water surface to be provided a constant supply of moisture and nutrients by splashing, periodic immersion and/or capillary action from the water. Similarly, Vollertsen et al. (2008) found that corrosion began at the water line, crept up to the crown and the heaviest corrosion had occurred close to the water line.

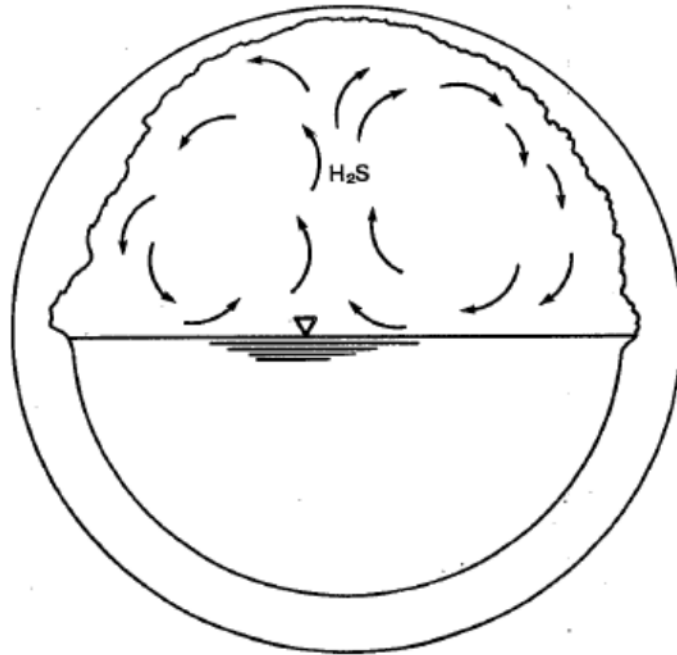

Figure 16 Distribution of Corrosion in a Sewer
(EPA 1985)

Hypotheses

It is hypothesized that the diurnally exposed slime layer impacts the sewer atmosphere $[H_2S]$. Testing will first be performed to determine if the diurnally exposed slime layer emits H_2S directly to sewer atmosphere. If true, this will increase the $[H_2S]$ with exposure of the slime layer. If this hypothesis is not supported, testing will be performed to determine if the diurnally exposed slime layer removes H_2S from the sewer atmosphere.

Methodology

Introduction

To test the hypotheses, a testing program was developed to evaluate the impact of an exposed slime layer on the $[H_2S]$. Slime layers were grown on samples that were placed in a chamber under controlled conditions and changes in $[H_2S]$ were logged and analyzed. If H_2S emission was not observed, the addition of H_2S would be used to determine the impact of an exposed slime layer on the $[H_2S]$.

Samples

Polyvinylchloride (PVC) samples, nominal 3" x 4", were cut from available scrap pipe. A total fourteen samples were cut, although not all were utilized for slime growth and testing. They were cut from a derelict piece of 21" PVC pipe that had been stored in an outdoors area for years, addressing concerns that fresh PVC can inhibit microbial growth (Vollertsen, personal communication, 2014).



Figure 17 PVC Coupons Used for Thesis Testing

Test Chamber

The Test Chamber was assembled using 4" PVC pipe and fittings. See Figure 18.

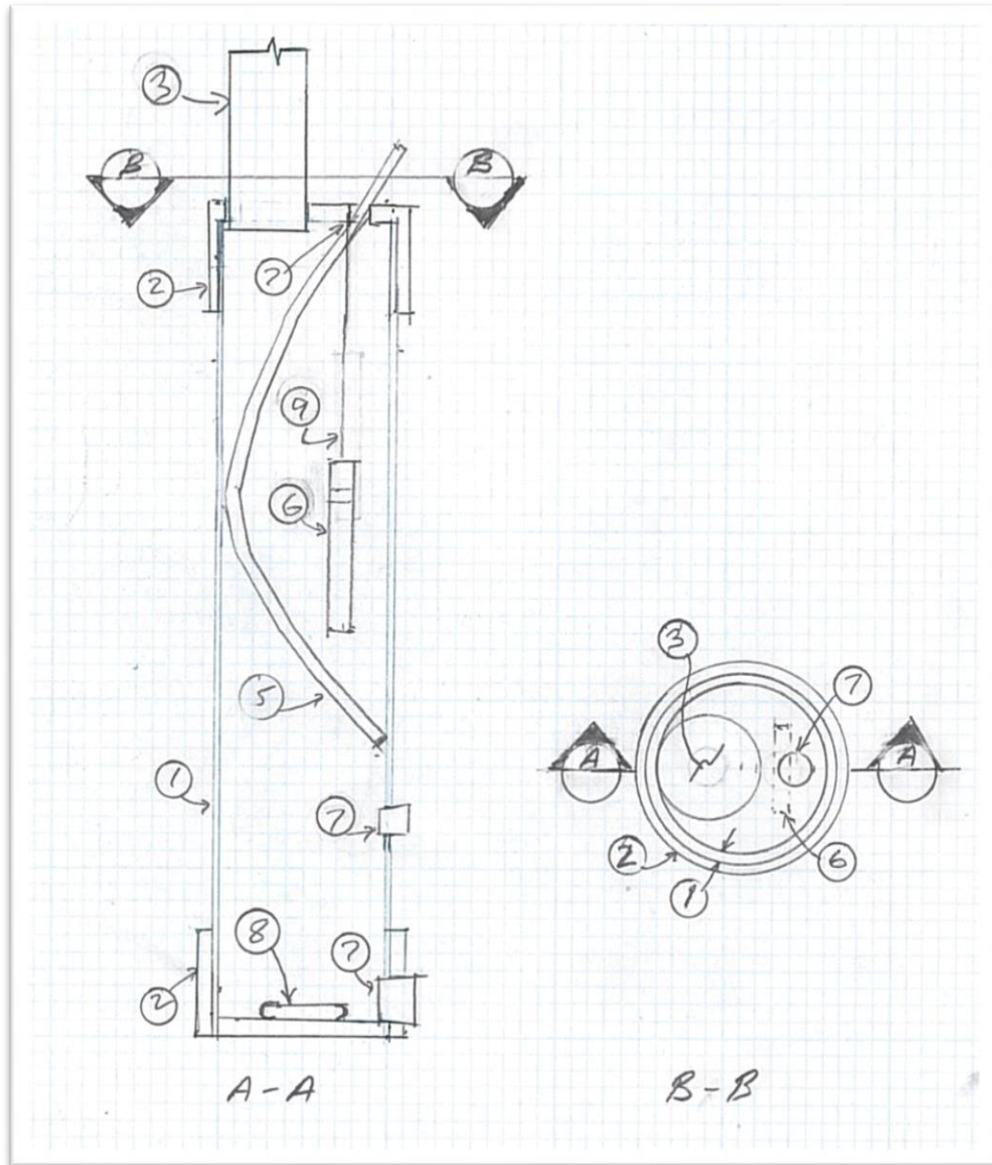

Figure 18 Test Chamber Elevation and Plan

The Figure 18 keyed notes are: 1) 4" pipe; 2) PVC cap; 3) OdaLog in cap; 4) Sample hanging in test chamber; 5) Calibration gas tube is shown while filling chamber – see test sequence step #11 in Figure 31; 6) Sample hung in chamber; 7) Plugs; 8) Stir bar; 9) Nylon line.

OdaLog Data Logger

H₂S concentrations were measured using OdaLog Hydrogen Sulfide Gas Loggers (Figure 19) which record H₂S concentrations and ambient air temperatures on a user selected interval from one second to one hour. For this testing, a reading was recorded every second. The OdaLog has a maximum capacity of 42,000 data points, resulting in a maximum test time of 11.67 hours during this testing program.



Figure 19 OdaLog Set in Cap



Figure 20 Cap and OdaLog Ready to Place on Chamber with Sample



Figure 21 Bottom View of Cap with OdaLog

An OdaLog utilizes an electrochemical sensor supplied by City Technology.

Siddique (2008) states: “The current generated is proportional to the amount of reactant gas present.”

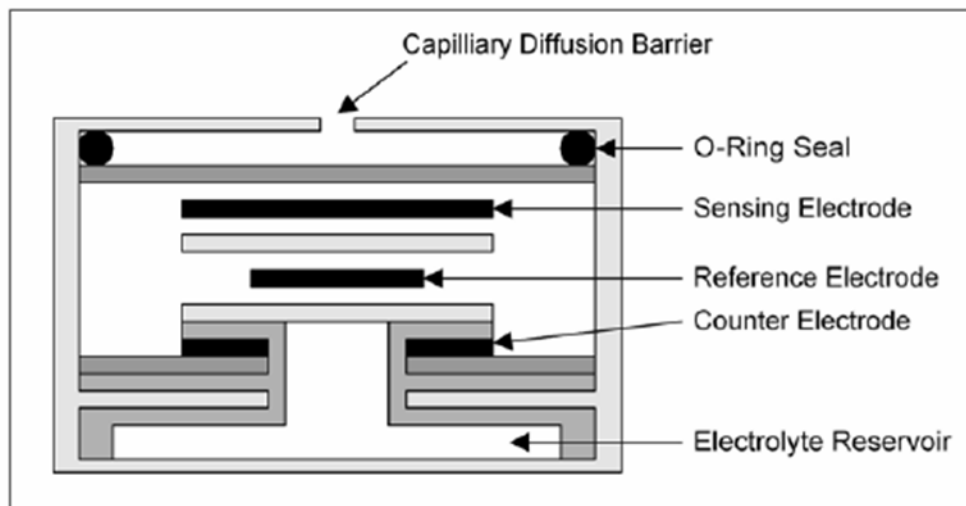
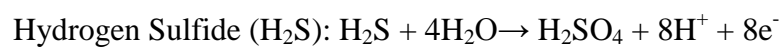

Figure 22 Sensor Schematic (City Technology)

City Technology technical literature provides the above schematic and the following information:



The sensor consumes a portion of the H₂S present and converts it to H₂SO₄. OdaLog and City Tech have not provided specific sensor consumption rates but gave the following statement. “I believe in the real world testing H₂S in a sewer environment there would be no affect from the OdaLog sensor absorbing the H₂S. But in a small test chamber it would absorb the H₂S and affect the reading.” (Brian Worth – Thermo Fisher Scientific, author’s communication via Lindy Eppinger, 9/16/2013). Based on Thesis testing, uptake rates were computed for the sensor, see Dry Chamber Testing.

Calibration Gas

Calibration gas was used to periodically calibrate OdaLogs. The gas consists of 50 ppm H₂S and the remaining gas is nitrogen (N₂). The gas is controlled by a regulator at a rate of 0.25 L / minute.

Data Processing

After each set of tests, the OdaLog was downloaded to computer. This data was in an .oda format as provided by the proprietary OdaLog software. The data is exportable to .csv format that is convertible to .xls (Excel) format. Trends and patterns were therefore evaluated using the graphical results and processed using Excel’s statistical functions.

Slime Growing Location

The samples were hung in the Effluent Channel immediately downstream of the Preliminary Treatment Facility (PTF) at the Water Authority Southside Water Reclamation Plant (SWRP) at 4201 Second St. SW, Albuquerque, NM. The PTF removes rags and grit and the exiting flow is collected in the testing channel and then routed to primary clarifiers for further treatment. Figures 23, 24 and 25 show the routing of influent flow from the Influent Box that combines flow from the Tijeras and Edith Interceptors

and Lift Station 20 and routes it through four bar screens in the PTF, i.e. Screens #2, 3, 4 and 5. On the south effluent side of the PTF, each of the four bar screens has a gate and the gate cover plate allowed access and hanging of the sample.

A level detector is located in the PTF Effluent Channel adjacent to Screen #5 where the most downstream sample was hung. The level detector is used for SWRP operations and water surface elevation data is collected on a 15 minute interval. During testing, it was found that the water surface varies approximately 1.6 feet with the minimum depth occurring at approximately 7 a.m. The test coupons used in the thesis testing were set at an elevation that was continuously submerged. One continuously submerged slime sample and one diurnally exposed slime sample were removed, the slime scraped and weighed. As would be expected, the exposed slime had considerably lower moisture content than the continuously submerged sample, 37.43% vs. 90.65%. The exposed slime layer moisture content is probably lower than that found in sewers because the air is continuously removed and scrubbed for odor control.

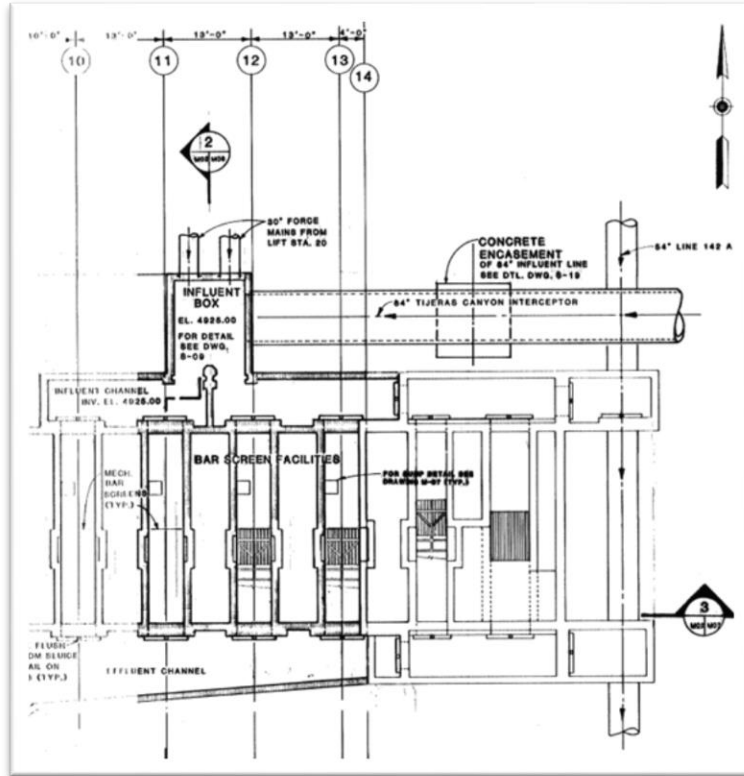

Figure 23 PTF Plan View - Effluent Channel Lower Left

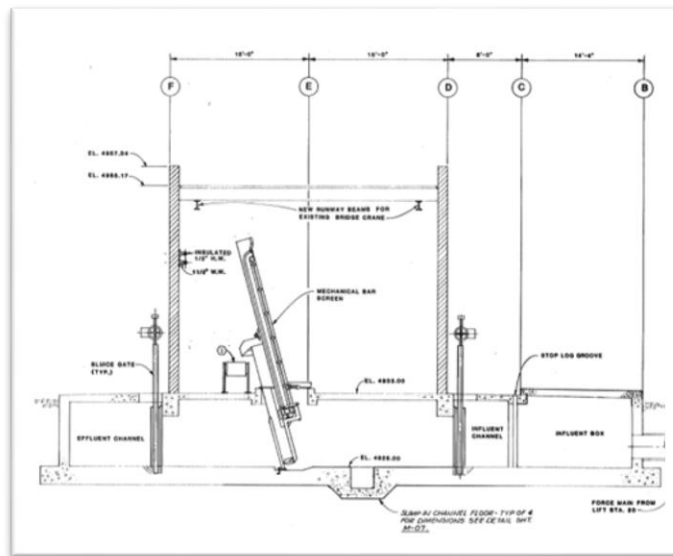

Figure 24 Section 3 Through PTF - Effluent Channel to Left
 -See Figure 23 for Cut

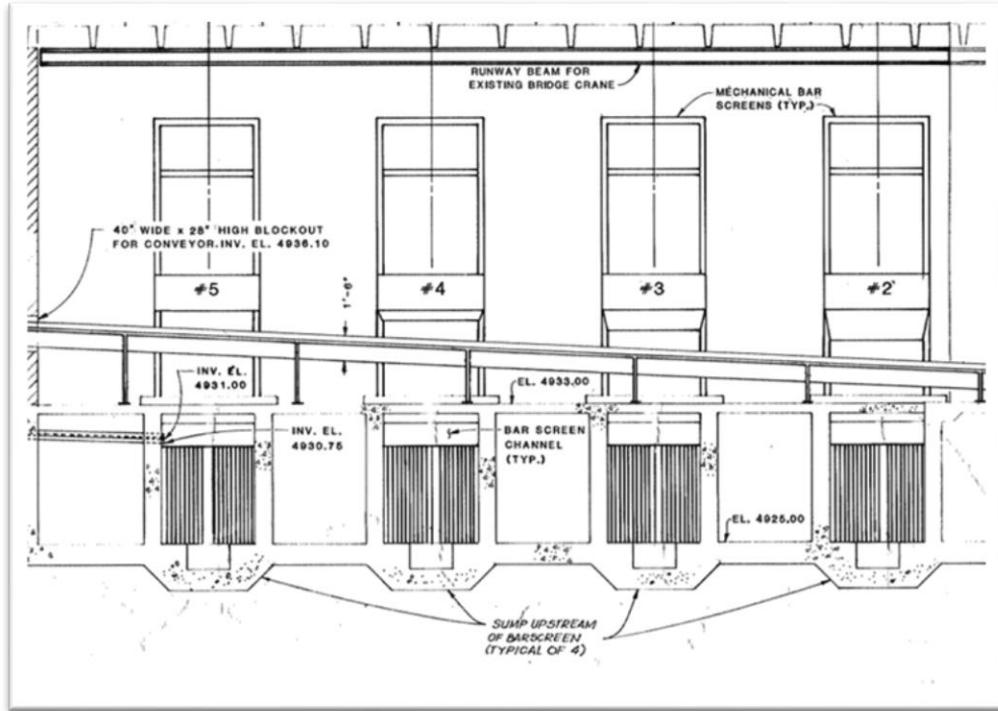

Figure 25 Section 2 Through PTF
See Figure 23 for Cut



Figure 26 Gate Cover and Plate Over Effluent Channel



Figure 27 South Side of PTF - Looking Downstream Along Effluent Channel



Figure 28 PTF Channel Looking Downstream - Slide Gate on Right



Figure 29 Sample Hanging in Effluent Channel

Test Protocol

Slime Sample Testing

Slime samples are defined as those coupons that were hung in the PTF Effluent Channel. Slime quickly grew and covered the coupon. See Figure 30. The dark color is due to FeS resulting from the addition of FeCl_3 for odor control (Nielsen 2005c, p. 54).



Figure 30 Sample Before and After Hanging in Flow Eight Days

The slime sample procedure was developed after the completion of the dry chamber and wet chamber testing. The slime sample procedure was developed and performed at the same time as the sewage samples. The slime sample testing was the most involved and evolved from the prior testing, therefore it is explained first.

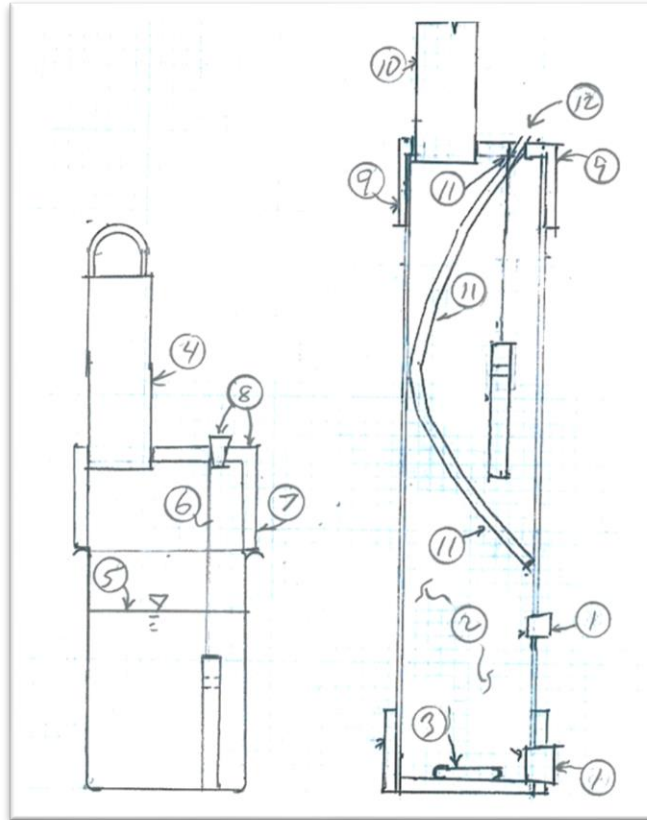

Figure 31 Test Sequence for Slime and Sewage Samples

Based on Figure 31, the test sequence was: 1) Plug side holes. 2) Condition chamber. 3) Place chamber on stirring plate and place stirring bar in chamber. Turn on stirring plate. 4) Install OdaLog in chamber cap. Turn on OdaLog. 5) Partially fill the bucket with enough sewage to more than cover the sample. 6) Tie the fishing line to the sample and cut the braided line that had been holding the sample. 7) Move cap onto the bucket and pull the fish line taut with the sample on the bottom of the bucket. 8) Set plug and tape the fishing line to the cap to prevent from slipping. 9) Move the cap and place on top of the chamber. 10) Observe the OdaLog readings of $[H_2S]$ until the readings dropped to zero and stayed there. 11) Then remove the cap plug and insert the calibration gas tube and open the calibration gas control. 12) After four minutes shut off calibration gas, remove tube and replace plug. Run test.

The tests were typically run until the [H₂S] reading was zero. Conditioning the chamber, test sequence step #2, was intended to provide an equivalent starting condition for each test in terms of moisture and to remove sewage residue from a previous test. Enough distilled water was poured into the chamber to wet the chamber and rinse out residue from previous test. The chamber was shook to wet the entire interior and remaining rinse water was poured out. The chamber was placed upside down for one minute, wiped with a rag, and finally placed right side up for one minute. The sewage used for test sequence step #5 was obtained from the PTF Effluent Channel. Figures 32 and 33 demonstrate test sequence step #6. During test sequence #11, the temporarily removed plug was placed next to the calibration gas tube. This partially blocked the hole to a consistent degree.

The sewage and slime sample testing was performed at the PTF Blower Building, immediately south of the Effluent Channel. A typical set up is shown in Figure 34. The plate was removed to access the channel, as seen in Figure 26. The sample was tied to a nylon rope that was tied to a structural angle, as seen in Figure 32, and hung into the channel, as seen in Figure 29.



Figure 32 Slime Sample Showing Accumulation on Braided Line before Cutting and Replacing with Nylon Line



Figure 33 Slime Sample after Tying with Nylon Line - Ready for Testing



Figure 34 Sampling Set-Up in PTF Blower Building

Sewage Sample Testing

Control testing was provided by clean coupons that were placed in the sewage bucket for two minutes to condition the coupon to an equivalent sewage / moisture content to the slime samples. These control samples are identified as sewage samples. The procedures, location and equipment were identical to the slime sample testing. The slime sample and sewage sample tests were identical with the exception of the sample being tested and the greater time required to cut and retie the slime sample prior to carrying it in the bucket to the test location in the PTF Blower Building.

Wet Chamber Testing

A series of uptake testing was performed utilizing addition of calibration gas in a chamber conditioned with distilled water. This conditioning process was implemented within the slime and sewage sample testing as it allowed a more consistent starting point each test and helped to remove residual sewage that did drip during these tests. This

testing can be considered to be test sequence steps #1-4 and 11-12 (Figure 31). The wet and dry chamber testing were performed in the author's office (Figure 35).



Figure 35 Office Set-Up for Dry Chamber Testing

Dry Chamber Testing

The first Thesis testing performed was the dry chamber testing. This testing can be considered to be test sequence steps #1, 4 and 11-12.

Results

Sewage and Slime Tests – Prior to Adding Calibration Gas

The Sewage and Slime samples exhibited a similar [H₂S] pattern prior to the calibration gas was added. The result of a typical test is shown in Figure 36 in which the [H₂S] is measured in ppm on the Y-axis versus the time in the X-axis. An initial increase in [H₂S] was observed in when the cap was placed on the bucket. This [H₂S] dropped quickly to zero when the cap was moved to the chamber and no emission was observed from the exposed slime layer.

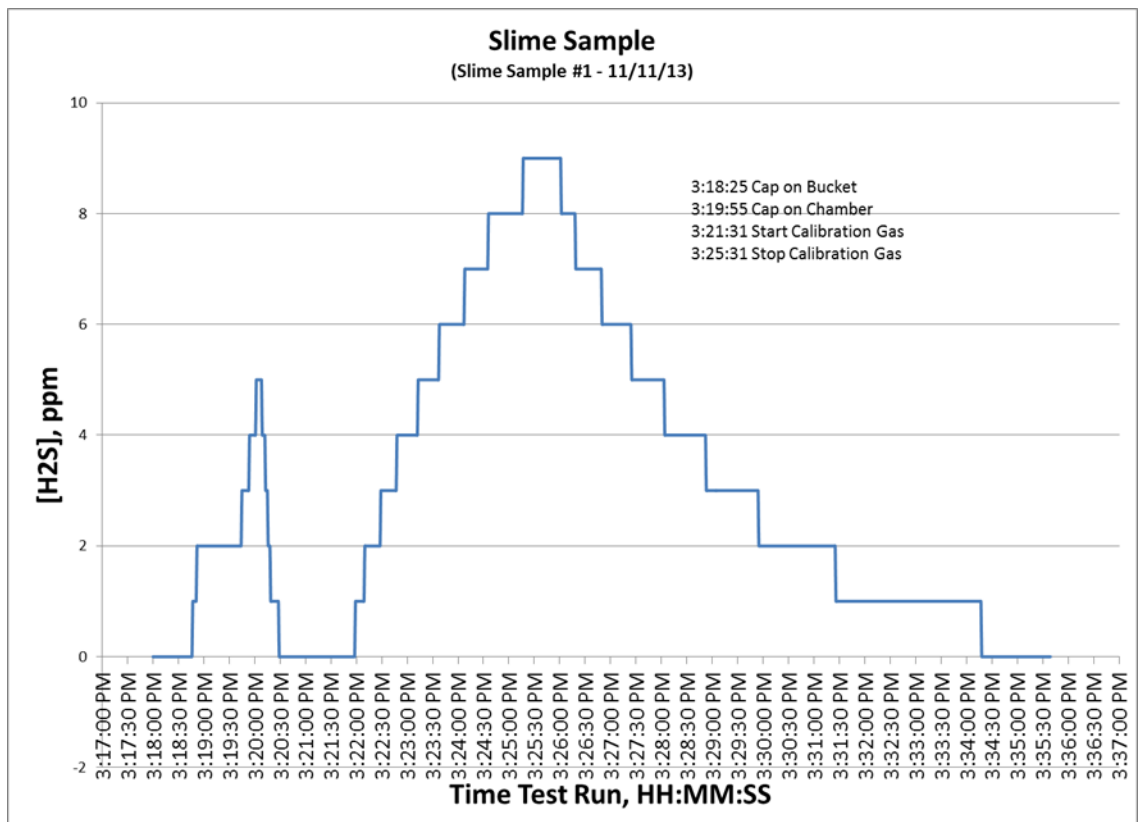

Figure 36 Sample Slime Sample [H₂S] Results

Chamber Cap on Bucket

The chamber cap was placed on the sewage bucket before being moved to the test chamber (Figure 37). The sewage bucket was filled with sewage and H₂S emitted into the air space confined between the cap and sewage bucket. As shown in Figure 36, this

resulted in measurable H_2S during the time the cap was on the sewage bucket which quickly dropped to zero when the cap was moved to the chamber.



Figure 37 Cap Placed on Sewage Bucket

No H_2S Emission from Exposed Slime Layer

As noted above, no H_2S emission was observed from either the slime or sewage samples, once placed in the Chamber. This disproves the hypothesis that the diurnally exposed slime layer emits H_2S directly to the sewer atmosphere.

No $[\text{H}_2\text{S}]$ was measured after the chamber cap was moved to the chamber despite the same sewage, which coated both the sewage and slime samples, was emitting significant H_2S immediately before when the chamber cap was on the bucket.

Test Results After Calibration Gas Added

The following four tests were performed in which 1.0 L of 50 ppm calibration gas was added to the test chamber: dry chamber, wet chamber, sewage sample and slime sample. At the start of each test, the $[\text{H}_2\text{S}]$ was 0 ppm. The following graph shows the $[\text{H}_2\text{S}]$ versus time, with time = 0 when the calibration gas was first fed into the chamber.

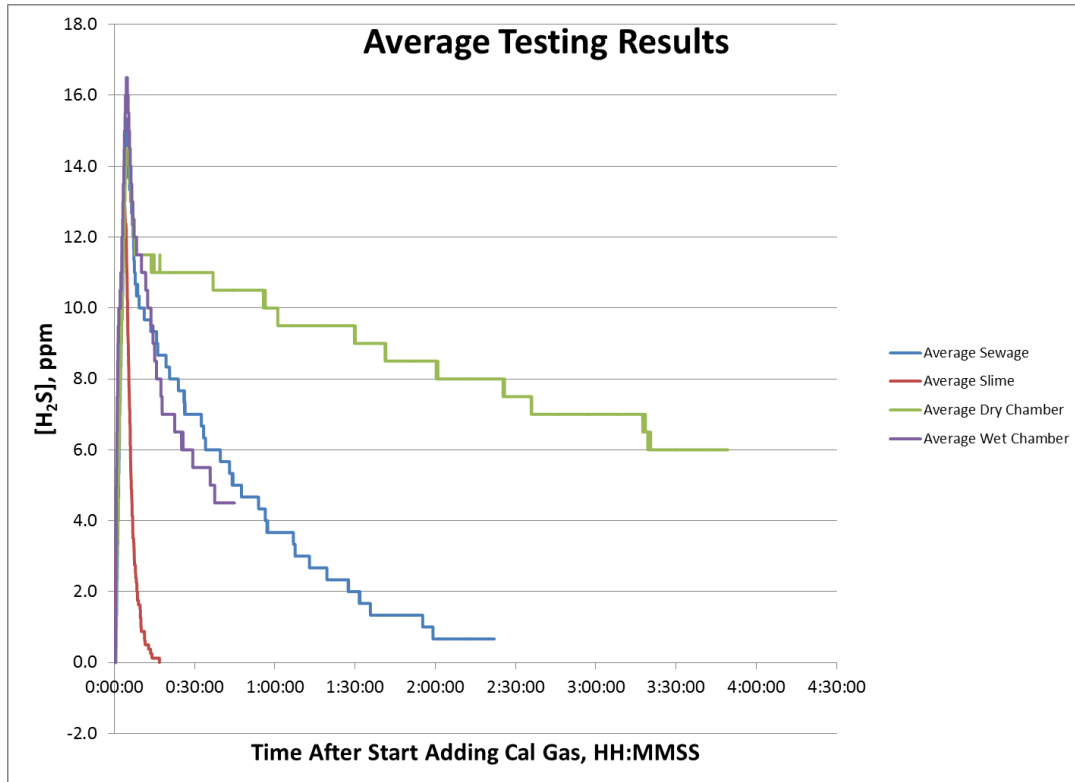

Figure 38 Average Testing Results

In all testing, introduction of the calibration gas resulted in a rapid rise in [H₂S] that peaked shortly after the cal gas was shut off and then declined to zero. The rise portion as a result of calibration gas addition was relatively consistent for the various tests but a significant difference was found in the rate of decline for the four test types, i.e. dry chamber, wet chamber, sewage, and slime. The dry chamber had the slowest uptake of H₂S, the wet chamber and sewage sample tests had roughly equal uptake and the slime sample uptake was the fastest. The conditions of the tests were controlled except for specific differences, to which the difference in H₂S uptake is attributed in the following analyses by test type.

Dry Chamber Testing / Uptake Due to Sensor

Two dry chamber tests were run in which the calibration gas was added and the [H₂S] was allowed to decline without adding additional calibration gas (Figure 39).

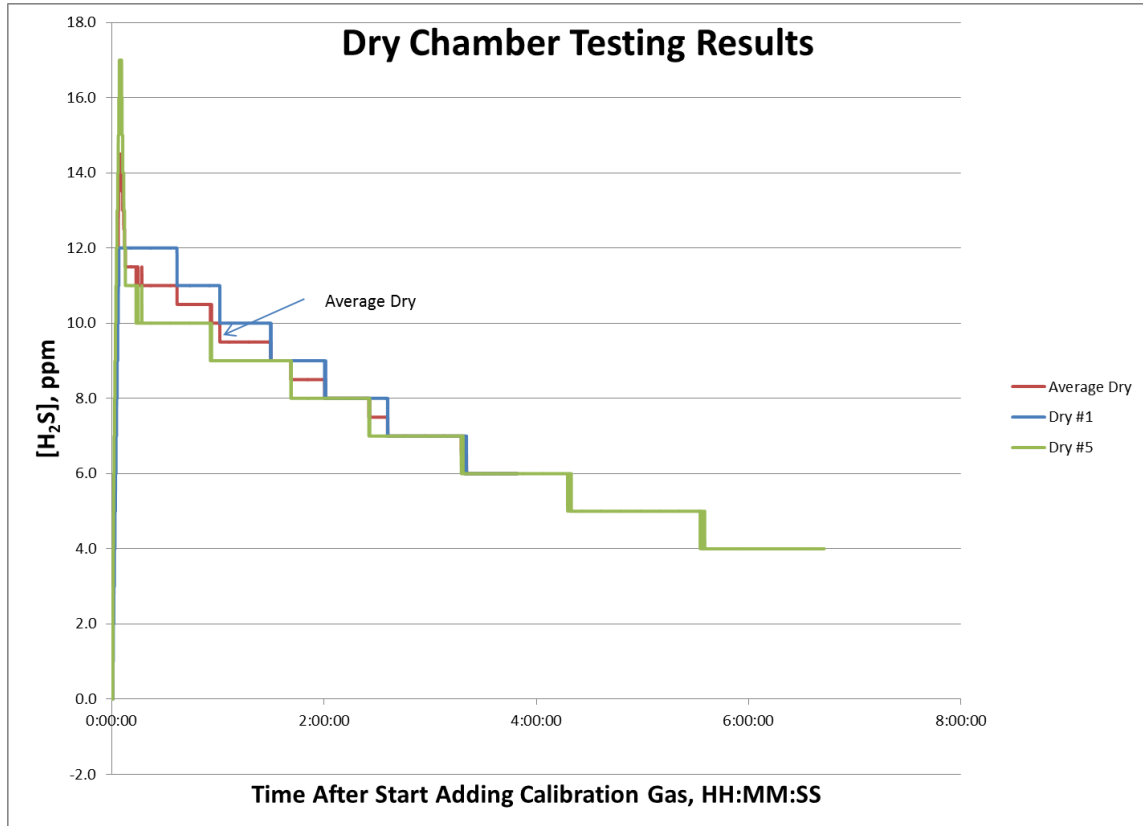

Figure 39 Dry Chamber Testing Results

As was the case in all four tests, the [H₂S] dropped after injecting the calibration gas into the chamber. The caps when pushed on tightly were found to be water tight and the plugs were securely placed for each reported test, therefore little H₂S is presumed to have escaped the test chamber during testing. The decline in observed [H₂S] during the control testing is therefore attributed to the test rig consisting of the chamber, caps and OdaLog.

Vollertsen et al. (2008) addressed hydrogen sulfide losses in a similar test rig. The losses, other than absorption and oxidation by the test surface, were identified to be

caused by absorptions by the wastewater within the setup, by absorption and oxidation by PVC surfaces, and by consumption by the hydrogen sulfide sensor. Through a pilot test process, Vollertsen determined these losses to be inconsequential and were ignored. However, the support data was not provided. In the dry chamber testing, there was no test surface and no water, leaving oxidation by the PVC surface and consumption by the sensor to account for the $[H_2S]$ decrease. It was presumed that oxidation by the PVC surface, if any, would be minimal after initial portion of each test, and the subsequent reduction would be attributable to the sensor. As discussed above the current generated is proportional to the amount of reactant gas present. Because the current is proportional to the consumption of H_2S , the mass of H_2S consumed is proportional to the $[H_2S]$ measured. This was validated by analysis of the test data.

For each test, the time required to drop 1 ppm, e.g. from 5 ppm to 4 ppm, was determined. The initial mass in the chamber at 5 ppm and the H_2S mass consumed to reach 4 ppm were computed. With this data, the mass portion consumed per time was computed and is summarized in Figure 40 which provides data from a total of five dry chamber tests. In three of the tests, additional gas was added during the test. These test results were therefore not reported in Figure 39.

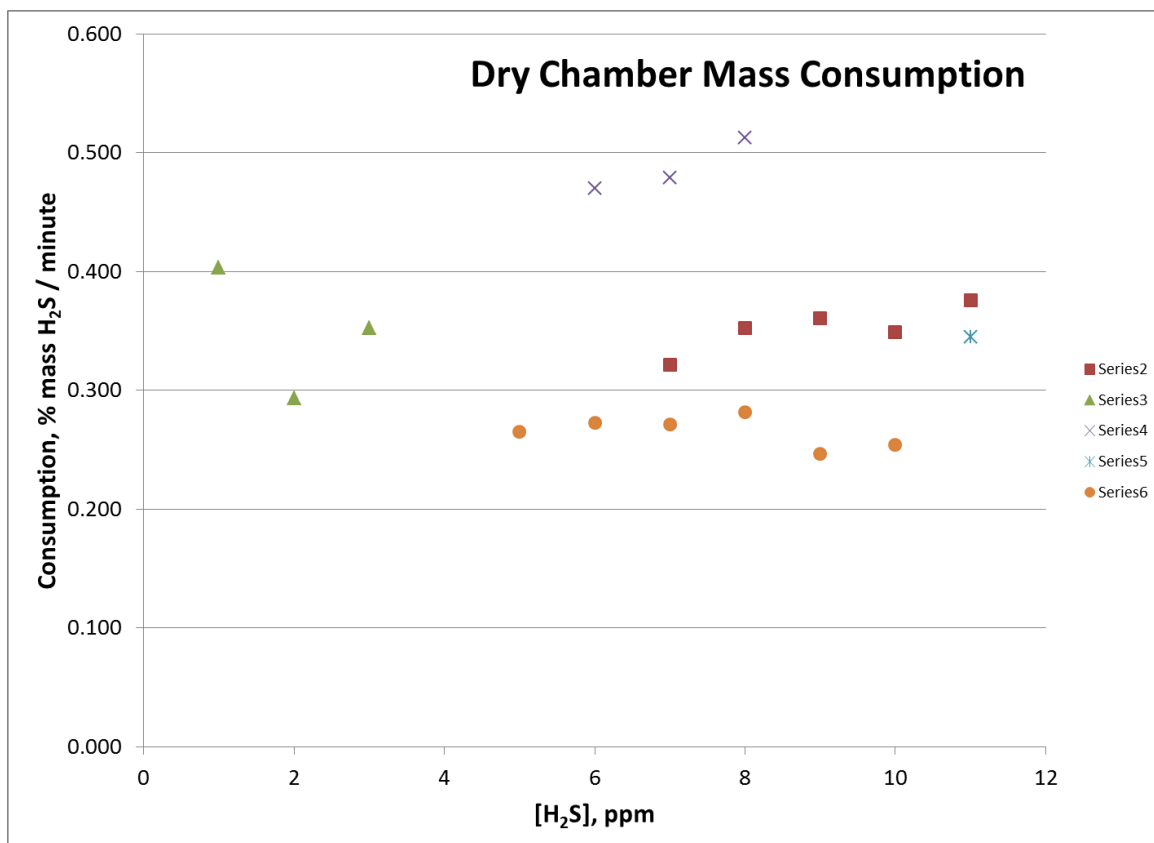

Figure 40 Dry Chamber Mass Consumption

The sensor uptake is a first order reaction. For the four tests with more than data point, the following plots were developed (Figure 41). The dry chamber rate constants, i.e. rate of conversion, for the four tests were determined to be 0.0037, 0.0041, 0.0052 and 0.0029 for an average of 0.0040 min⁻¹. Therefore:

$$R_{DC} = -k_{DC}C$$

Where,

R_{DC} = dry chamber rate of conversion, ppm / min

k_{DC} = 0.0040 / min

C = [H₂S], ppm

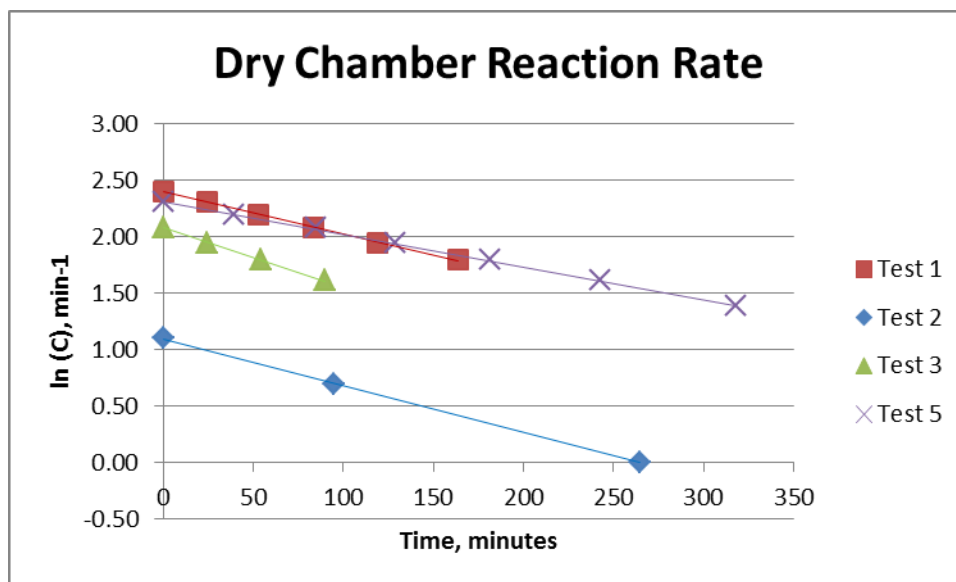

Figure 41 Dry Chamber Reaction Rate

For the subsequent reaction rate computations, i.e. wet chamber, sewage sample, and slime sample, time = 0 was set when the calibration gas started to be fed to the test chamber. This was not possible for all the dry chamber tests because tests 2 and 3 involved additional calibration being fed after the initial 1.0 L was introduced.

Wet Chamber Testing

Wet chamber testing is provided in Figure 42. The wet chamber testing showed a [H₂S] decline that was much quicker than for the dry chamber (Figure 38). The only difference between the dry and wet chamber testing was the wetting of the chamber prior to the wet chamber testing. Therefore the increased uptake rate is presumed to be caused by the moisture on the chamber inside surface.

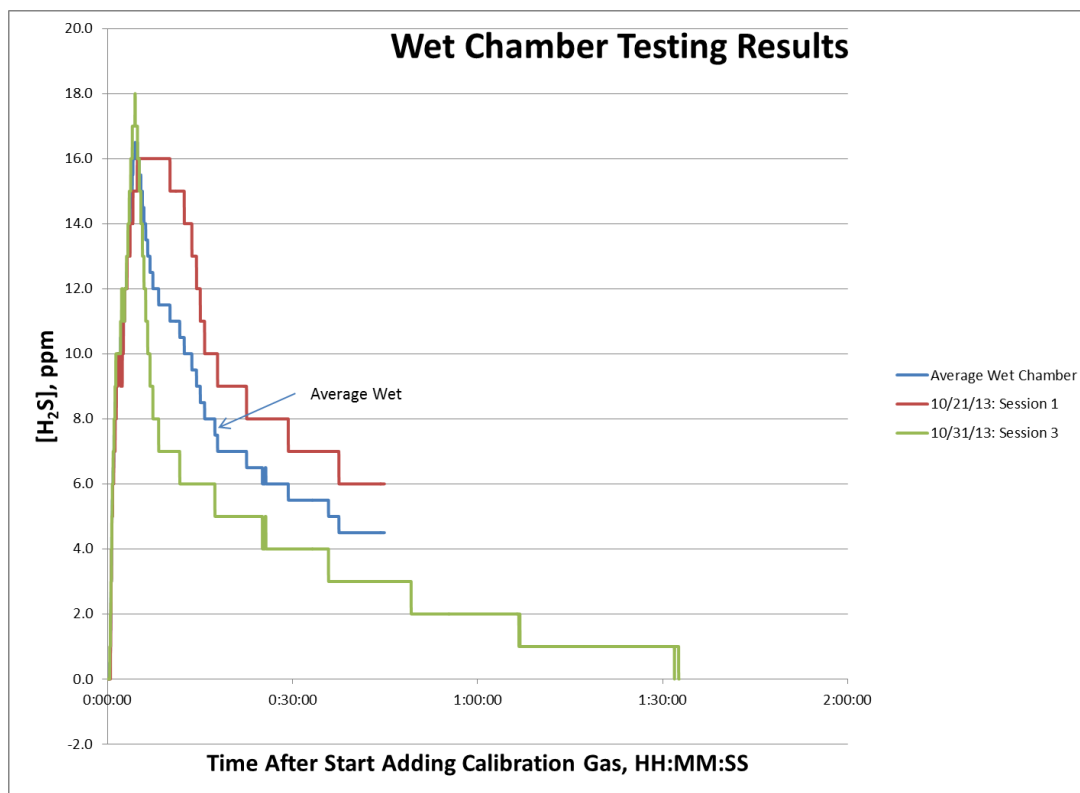

Figure 42 Wet Chamber Testing Results

As shown in Figure 5, sulfides are known to be oxidized in sewage, both chemically and biologically (Jensen, 2009). Nielsen (2005c, p. 38-39) states that the “stoichiometry of chemical sulfide oxidation was found to be relatively complex and thiosulfate and sulfate were identified as the main products” and “the oxidation products of biological sulfide oxidation under the conditions investigated was most likely elemental sulfur.” Because distilled water was used, biological oxidation is rejected. In this research, the coupon was covered by a thin layer of sewage that would maximize the adsorption rate of oxygen into the sewage, apparently resulting in rapid oxidation of any sulfides prior to emission.

The wet chamber uptake is a first order reaction. For the wet chamber tests, the following plots were developed (Figure 43). The dry chamber rate constants, i.e. rate of

conversion, for the two tests were determined to be 41.204, and 32.307 for an average of 36.8 / min. Therefore:

$$R_{WC} = -k_{WC}C$$

Where,

R_{WC} = wet chamber rate of conversion, ppm / min

$K_{WC} = 36.8 / \text{min}$

$C = [\text{H}_2\text{S}], \text{ppm}$

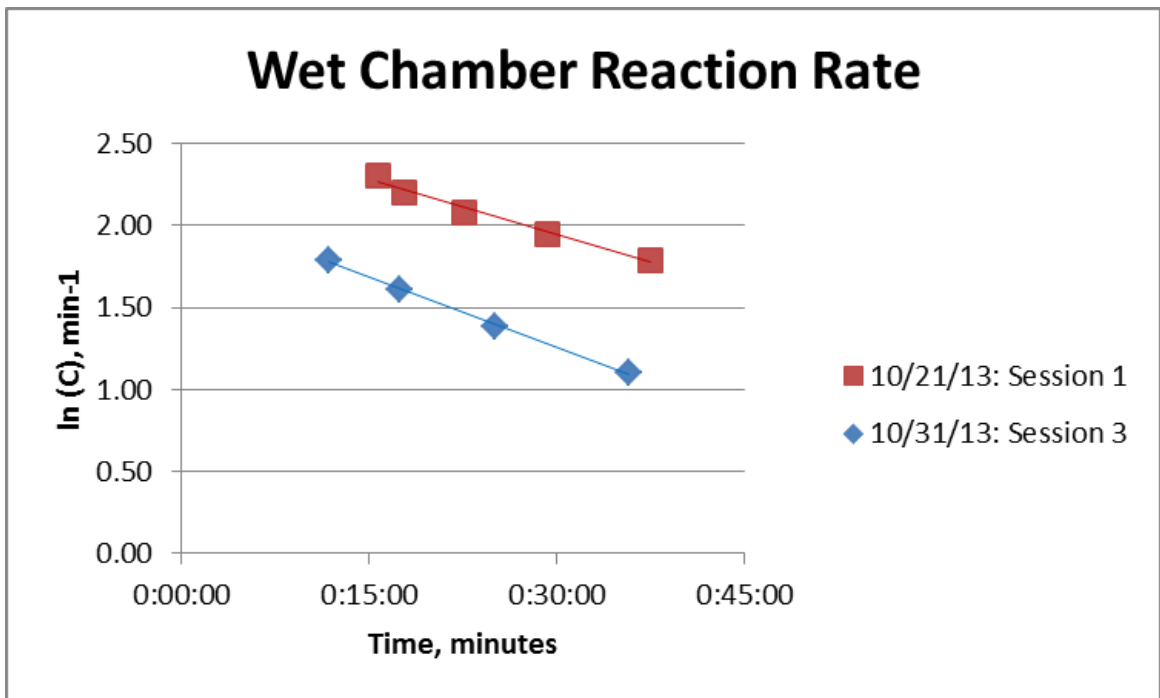

Figure 43 Wet Chamber Reaction Rate

Sewage Sample Testing

The decay curve for the sewage samples (Figure 43) was close to the wet chamber testing (Figure 38). The only difference between these two tests was the presence of the coupon with a thin layer of sewage. It is presumed that the same chemical oxidation identified in the wet chamber testing is also the cause of the $[H_2S]$ decline in the sewage sample testing.

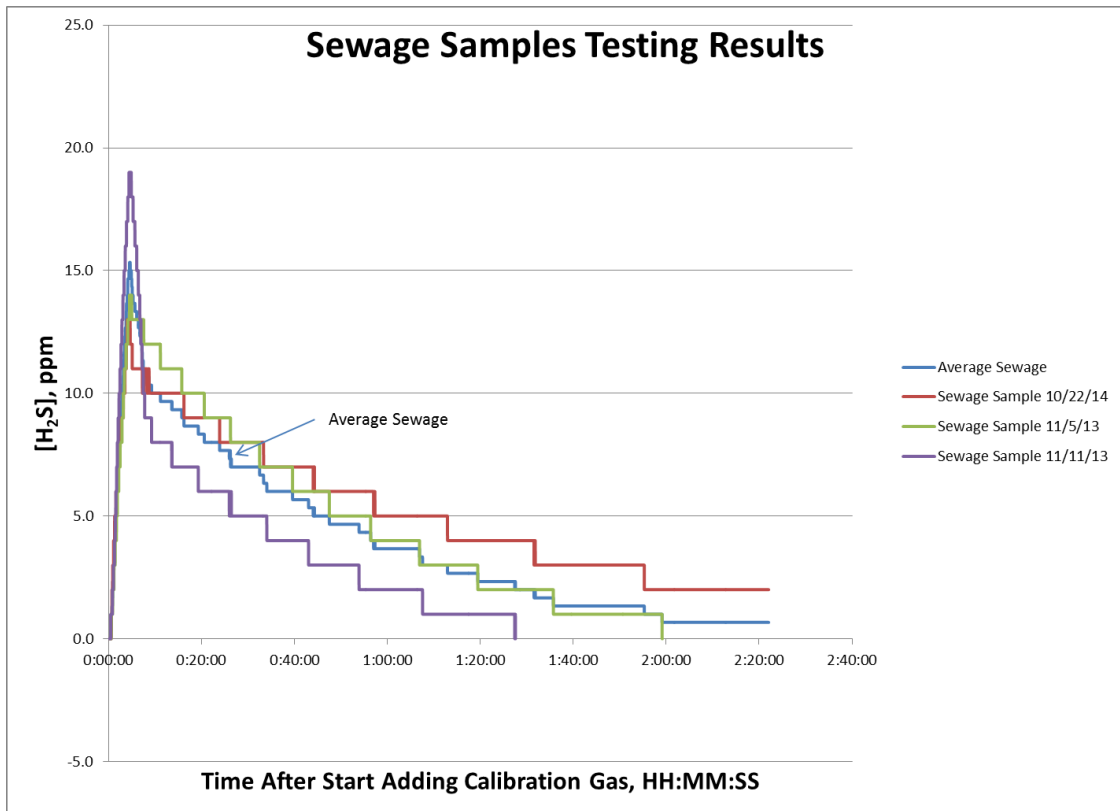

Figure 44 Sewage Sample Testing Results

The sewage sample uptake is a first order reaction. For the sewage sample tests, the following plots were developed (Figure 45). The sewage rate constants, i.e. rate of conversion, for the three tests were determined to be 21.970, 34.587 and 43.762 for an average of 33.4 / min.

Therefore:

$$R_{SAS} = -k_{SAS}C$$

Where,

R_{SAS} = sewage sample rate of conversion, ppm / min

$K_{SAS} = 38.1 / \text{min}$

$C = [\text{H}_2\text{S}], \text{ppm}$

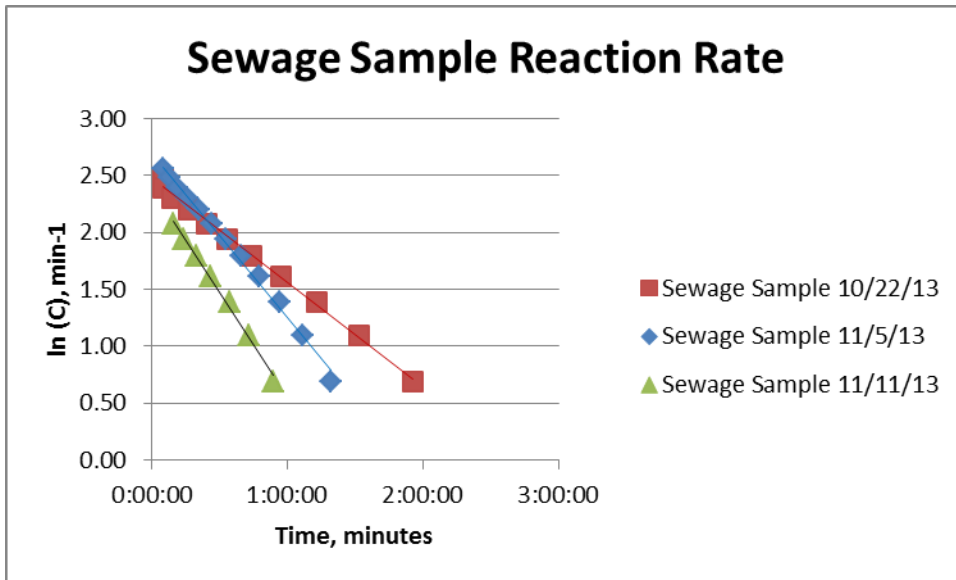

Figure 45 Sewage Sample Reaction Rate

Slime Sample Testing

The decay curve for the slime samples was the steepest (Figure 38). The only difference between the sewage and the slime tests was the slime layer on the slime samples, therefore the increases uptake was attributed to slime layer. The difference was significant and, because no reason for increased chemical oxidation was identified, is attributed to biological activity.

The eight slime sample test results are plotted in Figure 45. As discussed below, the scatter in the results is possibly due to a difference in mixing with the stir bar. It is noted that Slime Sample #2 10/31/13 which reached the highest $[\text{H}_2\text{S}]$ at 24 ppm, nearly

the concentration of the calibration gas, also decayed the fastest, indicating that in this particular test the calibration gas may have risen to the top where a portion escaped.

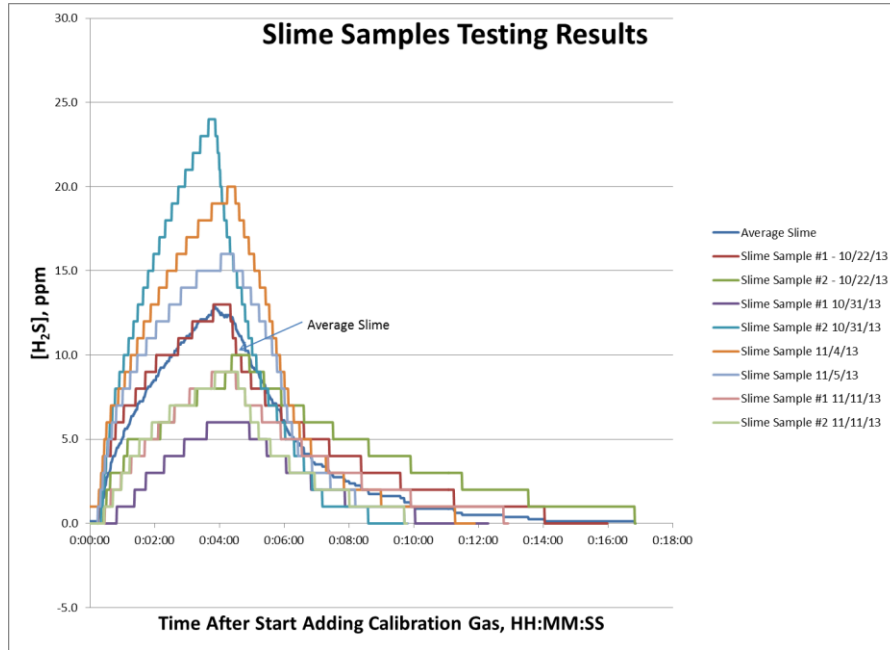

Figure 46 Slime Sample Testing Results

The slime sample uptake is a first order reaction. For the slime sample tests, the following plots were developed (Figure 47). The slime rate constants, i.e. rate of conversion, for the eight tests were determined to be 350.07, 428.57, 478.16, 539.45, 785.28, 848.80, 945.99 and 1104.10 for an average of 685.1 / min. Therefore:

$$R_{SL} = -k_{SAL}C$$

Where,

$$R_{SL} = \text{slime sample rate of conversion, ppm / min}$$

$$K_{SL} = 685.1 / \text{min}$$

$$C = [H_2S], \text{ ppm}$$

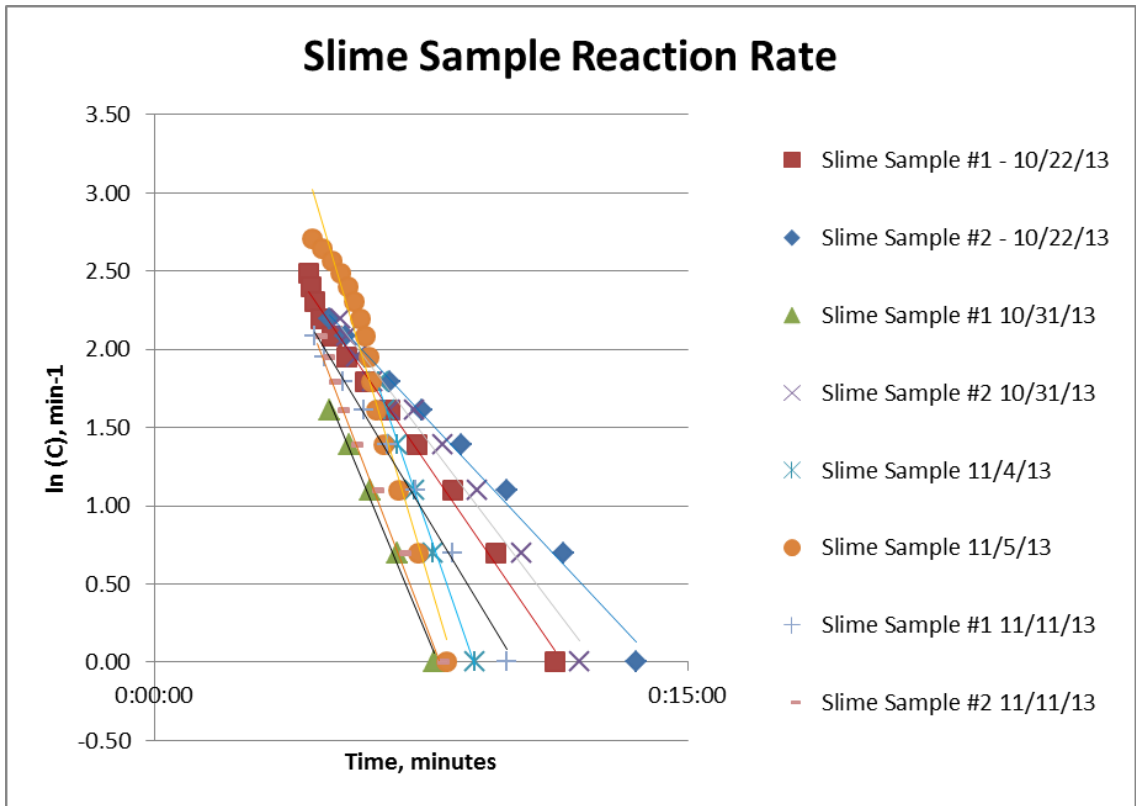

Figure 47 Slime Sample Reaction Rate

However, the slime tests included the chemical oxidation from the sewage test. Therefore, the difference in uptake was determined between the slime and sewage tests was computed versus the surface area of the slime sample, resulting in Figure 48 in slime uptake in mass removed per unit area per unit of time is plotted versus $[H_2S]$. The removal rate in Figure 48 is equivalent to the removal rates in Figure 8, i.e. both address atmospheric H_2S uptake relative to $[H_2S]$ by an exposed surface. In the Figure 8, the exposed surface is the pipe surface exposed to the sewer atmosphere and in Figure 48 the exposed surface is the previously submerged slime layer.

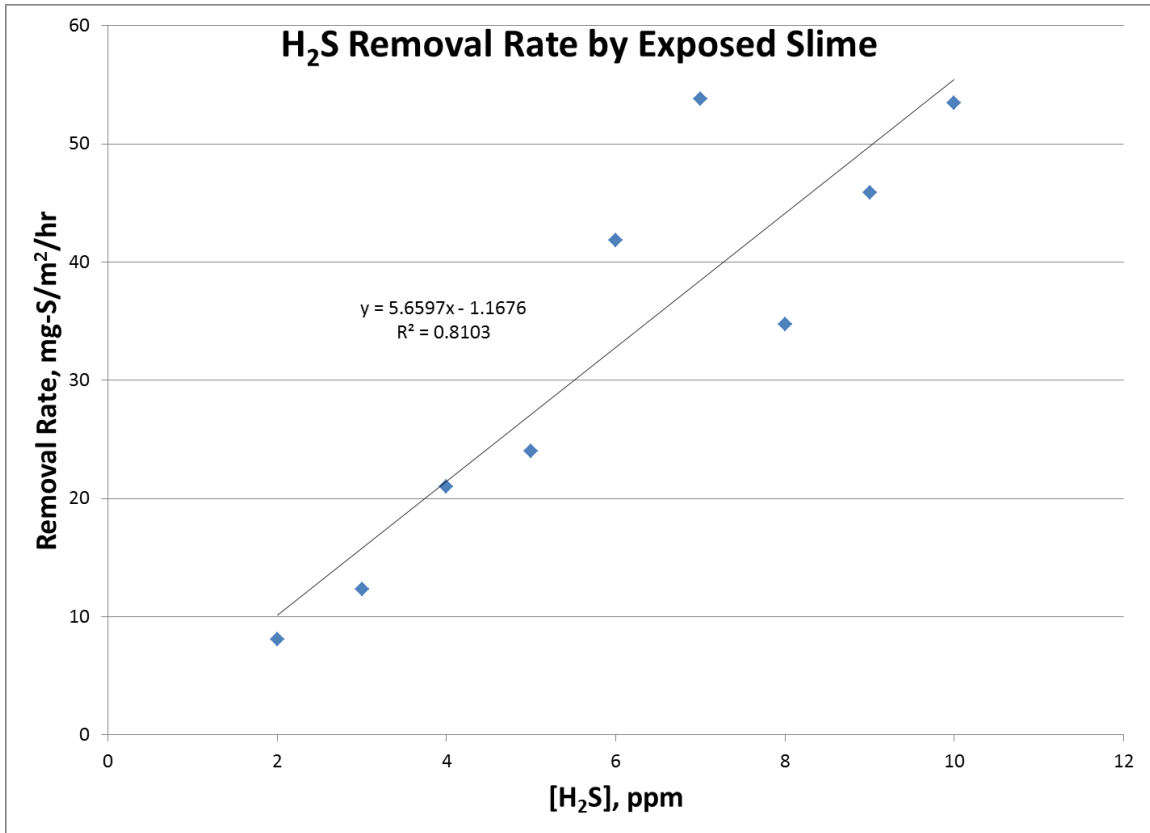

Figure 48 H₂S Removal Rate by Exposed Slime

Maximum [H₂S] from Calibration Gas versus Measured Levels

1.0 L of 50 ppm calibration gas (four minutes at 0.25 L / min) added to a 2.79 L chamber results in a [H₂S] of 17.9 ppm. This is based perfect displacement of the air in the chamber and no loss of H₂S out the top cap hole. However, in two slime tests levels greater than 17.9 ppm, but less than 25 ppm, were observed (Figure 46). The calibration gas is essentially nitrogen gas which has a specific gravity of 0.97, therefore it would have a slight tendency to rise. Inadequate stirring may have resulting in concentration gradients, which may explain some of the variation in the peak concentration levels in the slime testing.

Implication of Diurnally Exposed Slime Layer on [H₂S]

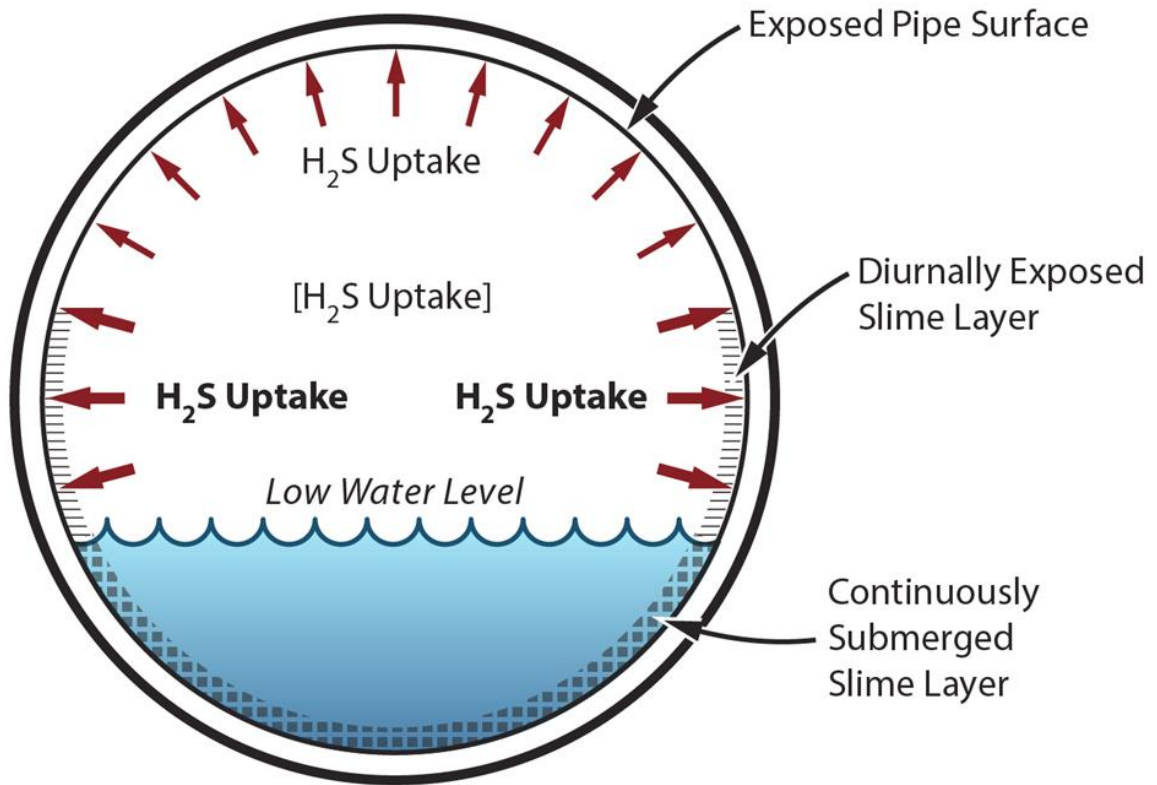

Figure 49 Demonstrated H₂S Removal by Diurnally Exposed Slime Layer

H₂S in the sewer atmosphere is primarily removed by biological and chemical oxidation on the exposed pipe surface and for concrete the “biological hydrogen sulfide oxidation typically accounted for more than 95% of the total oxidation rate and that chemical oxidation played a minor role” (Vollertsen et al. 2008, p. 168). For exposed plastic pipe surface, Nielsen (2008b, p. 5207) states “The plastic surfaces are inert and will not neutralize the acid. It is therefore likely that the pH will eventually become inhibitory for the sulfide oxidizing bacteria, thereby reducing the rate of sulfide oxidation.” In Figure 8, Nielsen et al. (2008b) quantify the exposed pipe surface uptake rate varies widely depending on the pipe material type. For instance, at [H₂S] = 10 ppm,

Nielsen reported (author's communication, 2014) the uptake rates were 93.22, 3.95 and 5.04 mg S m⁻² h⁻¹ for concrete, PVC and HDPE respectively.

The uptake of H₂S by the diurnally exposed slime layer is an additional removal mechanism that has not previously been recognized. The additional uptake will vary diurnally, depending on the area of the exposed slime layer. The impact on the resulting [H₂S] will decrease with higher uptake rates on the exposed pipe surface, and increase with lower exposed pipe uptake rates.

The previously discussed sewer in San Jacinto will be used as an example (Figure 50) in which the [H₂S] is presumed to be a constant 10 ppm. The uptake attributable to the exposed pipe surface is a constant for each pipe material because the area is a constant regardless of pipe material and the uptake rate is a constant dependent on the pipe material. The uptake rate attributable to the slime layer is presumed to not be dependent on the pipe material because it is covered by slime. The slime layer uptake therefore varies diurnally in accordance with the amount of slime layer exposed, and when added to the pipe surface uptake, results in the total uptake for each pipe material. This example is for illustration of concepts only and is based on a constant [H₂S] throughout the day, of course this is incorrect, and a constant slime uptake rate through diurnal cycle, which has not been demonstrated.

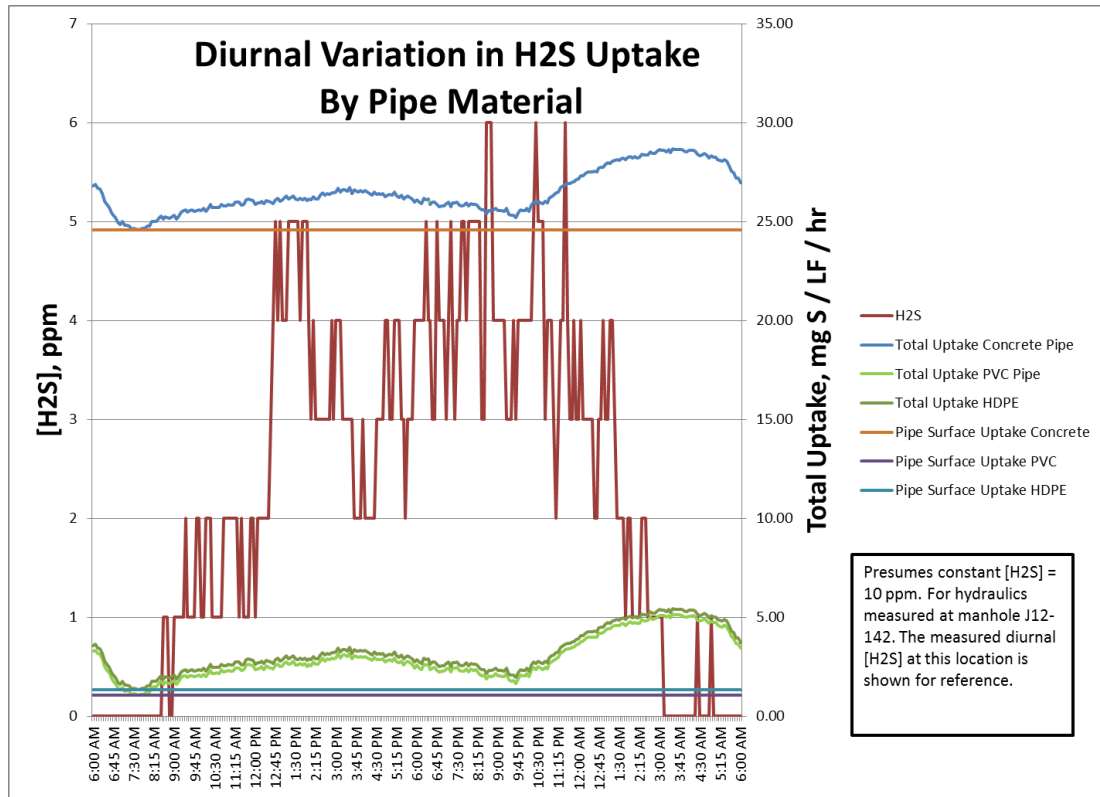

Figure 50 Example of Diurnal Variation in H₂S Uptake by Pipe Material

If the exposed slime layer were the sole driving factor in the [H₂S], the area of exposed slime layer would be out of phase with the [H₂S], i.e. one would rise as the other falls. It is seen therefore that the exposed slime layer does not fully describe the diurnal [H₂S] as both rise in morning after the morning peak flow. However, the relationship does hold for much of the rest of the day.

While not the predominant factor in the diurnal [H₂S], the exposed slime will have an impact, especially on PVC lines. In the Figure 50 example, the peak uptake for PVC would be 4.94 times the minimum for PVC. For concrete the peak uptake rate would only be 1.17 times the minimum for concrete.

Conversion to Altitude

Uptake rates in the Literature are computed in terms of mass per area per time ($\text{g S} / \text{m}^2 / \text{hr}$) and are presumed to be at approximately standard temperature and pressure (STP). This study was performed at 5000 feet rather than at sea level. Utilizing the ideal gas law and presuming the volume and temperature are constant results in:

$$n_2 = n_1(P_2/P_1)$$

Where n = amount of gas (moles) and P = pressure. Per

www.EngineeringToolBox.com, the pressure at 5000' (approximate elevation of the testing) is 84.3 kPa and is 101 kPa at sea level, resulting in both the air and the H_2S being approximately 83% the density under STP conditions. This means that a $[\text{H}_2\text{S}]$ measured in ppm in Albuquerque will contain 83% of the H_2S mass for the same $[\text{H}_2\text{S}]$ at sea level, i.e. standard pressure.

As previously discussed, the OdaLog sensor actually measures H_2S mass consumed and converts this to a ppm concentration. The sensor is regularly adjusted to match the calibration gas concentration, in this case 50 ppm, which after being released from the canister immediately adjusts to the local pressure. This provides for a 50 ppm calibration at any elevation although the mass consumed by the sensor to read a particular concentration, again in this case 50 ppm, is dependent on the local elevation. To simplify the analysis, this conversion is not made in these thesis calculations but is noted for consideration by other researchers.

Summary and Conclusions

Summary

Methodology

Slime was grown on samples hung in sanitary sewage after preliminary treatment consisting of screening rags and grit removal. These samples were placed in a test chamber in which H₂S concentrations were logged. The samples were tested under various conditions, specifically with and without the addition of H₂S.

Results

No H₂S emission was observed from the slime samples, disproving the original hypothesis of direct emission from the exposed slime layer. However, H₂S was observed to be removed from the simulated sewer atmosphere by the slime layer.

Implications to the Sewer Atmosphere Diurnal [H₂S]

The demonstrated removal of H₂S by the exposed slime layer provides a previously unidentified mechanism to reduce [H₂S]. This mechanism will vary diurnally as the slime layer is submerged and then exposed. This removal is more significant for non-corrosive pipe materials and where the diurnal flow patterns result in greater areas of exposed slime.

Limitations of Study

Not a Sewer

The test was performed under field laboratory conditions intended to replicate one aspect of a sewer, i.e., a slime layer that is exposed to the sewer atmosphere.

Removal Rate with Additional Exposure

All tests were performed nearly immediately after the slime sample had been exposed after being submerged. Testing is needed to determine the H₂S removal rates after the slime layer has been exposed for a period of time. However, the full exposure time may not be significant because the maximum exposure time period is at low flows during which time the [H₂S] typically drops to and stays at zero.

Vary Time Exposed to Atmosphere Diurnally

All tests were performed on slime samples that were continuously submerged. Testing is needed to determine the H₂S removal rates for slime layers that are exposed for varying portions of the diurnal cycle. Regarding slime layers, of course, only a diurnally exposed slime layer is able to remove H₂S from the atmosphere.

Decreased Oxygen

The calibration gas consisted of nitrogen (N₂) with a trace (50 ppm) of H₂S. Therefore the addition of 1.0 L of calibration gas in a 2.79 L test chamber would reduce the oxygen content by 36%. It is noted that the sewer atmosphere is likely to contain less oxygen than the urban atmosphere therefore, the decrease somewhat serves to replicate and actual sewer. The decreased oxygen is therefore not likely to be a significant issue.

Range of [H₂S]

Field sewers in which odor complaints occur typically have [H₂S] far in excess of concentrations tested.

Gas Mixing in the Test Chamber

Testing included a magnetic stirring bar at the bottom of the chamber. The stirring bar could not be directly observed and there is the possibility that it would rest against the chamber wall and be immobilized. See Figure 51. Adjustments in the stirring speed were

made during the testing to better assure that bar was rotating but it is possible some tests occurred without stirring of the air.



Figure 51 Stir Bar against Chamber Wall

Implications for Future Research

Address above Limitations

Testing could be done in which slime samples are:

1. Diurnally exposed to the sewer atmosphere before testing.
2. Tested for extended periods with additional dosing with H_2S .
3. Tested with $[H_2S]$ greater than 18 ppm.

Slime Characteristics

The utilization of atmospheric H_2S by the exposed slime layer may result in previously unidentified changes in this portion of the slime layer. The conversion of the H_2S may be similar to the process in the exposed pipe biofilm, which have been shown to be very complex, resulting in sulfuric acid. Or it may be similar to the submerged slime processes in which H_2S is converted to thiosulfate and elemental sulfur. The generation of sulfuric acid may be damaging to the slime layer.

Corrosion Patterns

Mori et al. (1992) and Vollertsen et al. (2008) identified greater corrosion near the water surface and declining toward the crown, opposite to that identified in EPA

(1985). Possibly the diurnally exposed slime layer contributes to greater corrosion. It is also possible that the higher ratio of submerged slime to the sewage volume, where the liquid surface intersects the pipe wall, results in a higher sulfide concentration in the bulk flow, resulting in higher H₂S emission and corrosion rates at the pipe wall.

Combined OdaLog & Flow Observations

Flow metering is routinely required in many systems in which detailed hydraulic data is gathered. It would be a simple matter to gather OdaLog data at the same time and share this with those researching diurnally exposed slime layers.

Model Diurnal Increase in Pipe Surface Uptake

The WATS model has recently been modified to model diurnal conditions. With additional research, it may be possible to justify modifying the model to account for the uptake by the diurnally exposed slime layer.

Conclusions

Atmospheric H₂S is significant concern relative to odors, worker safety, and corrosion. It is therefore beneficial to understand the processes that add and remove H₂S from the sewer atmosphere. Particularly for odor control and responding to odor complaints, it is beneficial to understand the diurnal [H₂S] patterns and the causes thereof.

The same submerged slime layer that emits H₂S to the bulk sewage flow and ultimately emits to the sewer atmosphere, has been shown to remove atmospheric H₂S. A portion of the slime layer is diurnally exposed to the sewer atmosphere and therefore may contribute to a portion of the diurnal [H₂S] pattern observed in the sewer atmosphere. The slime layer uptake of H₂S appears to be primarily biological.

References

- American Society of Civil Engineers [ASCE] (1989) Sulfide in Wastewater Collection and Treatment Systems; Manuals and Reports on Engineering Practice No. 69; Reston, Virginia.
- Æsoy, A., Østerhus, S. W., and Bentzen, G. (2002). Controlled treatment with nitrate in sewers to prevent concrete corrosion. *Wat. Sci. Tech.: Wat. Supply*, 2(4), 137-144
- Enfinger, K. L.; Stevens, P. L. (2006); *Sewer Sociology – The Days of Our (Sewer) Lives*; WEFTEC 2006
- Haan, B. (2009); *Diurnal Flows' Impact on Odor Generation*; Siemens White Paper; http://www.water.siemens.com/en/products/liquid_vapor_odor_control/odor_corrosion_control_chemical_products/Pages/diurnal-flows-odor-generation.aspx
- Holstad, M. (2010); *Data Driven Interceptor Cleaning*; WEFTEC 2010
- Holstad, M. (2012); *Why Aren't H₂S Concentrations Logical? (What We Are Missing In Daily H₂S Patterns)*; WEFTEC 2012
- Hvitved-Jacobsen, T. (2002); *Sewer Processes – Microbial and Chemical Process Engineering of Sewer Networks*; CRC Press
- Jensen, H. S. (2009) *Hydrogen sulfide induced concrete corrosion of sewer networks*; Section of Environmental Engineering, Aalborg University, Ph.D. Dissertation, UNIPRINT, Aalborg University, May 2009, ISBN 978-87-90033-58-3, ISSN 0909-6159
- Lahav, O.; Lu, Y.; Shavit, U.; Loewenthal, R. E. (2004) *Modeling Hydrogen Sulfide Emission Rates in Gravity Sewage Collection Systems*; *J. Environ. Eng.*, 130(11), 1382-1389

- Matos, J. S.; De Sousa, E. R. (1992) The forecasting of hydrogen sulphide gas build-up in sewerage collection systems; *Water Sci. Tech*; 26 (3-4), 915-922
- Mori, T.; Nonaka, T.; Tazaki, K.; Koga, M.; Hikosaka, Y.; Noda, S. (1992) Interactions of Nutrients, Moisture and pH on Microbial Corrosion of Concrete Sewer Pipes; *Water Research* 26(1), 29 – 37
- Nielsen, A. H.; Yongsiri, C.; Hvitved-Jacobsen, T.; Vollertsen, J. (2005a) Simulation of sulfide buildup in wastewater and atmosphere of sewer networks, *Water Science and Technology* Vol. 52, No. 3, pp. 201-208; IWA
- Nielsen, A. H., T. Hvitved-Jacobsen and J. Vollertsen (2005b) Kinetics and stoichiometry of sulfide oxidation by sewer biofilms, *Water Research* 39, 4119 – 4125
- Nielsen, A. H. (2005c) Oxidation and precipitation of sulfide in sewer networks; Section of Environmental Engineering, Aalborg University, Ph.D. Dissertation, UNIPRINT, Aalborg University, March 2005, ISSN 0909-6159
- Nielsen, A. H., J. Vollertsen and T. Hvitved-Jacobsen (2006) Kinetics and stoichiometry of aerobic sulfide oxidation in wastewater from sewers – Effects of pH and temperature. *Water Environment Research* 78(3), 275 – 283.
- Nielsen, A. H.; Vollertsen, J.; Jensen, H. S.; Madsen, H. I.; Hvitved-Jacobsen, T. (2008a) Aerobic and anaerobic transformations of sulfide in a sewer system: field study and model simulations, *Water Environment Research* 80(1), 16-25
- Nielsen, A. H.; Vollertsen, J.; Jensen, H. S.; Wium-Andersen, T.; Hvitved-Jacobsen, T.; (2008b) Influence of pipe material and surfaces on sulfide related odor and corrosion in sewers, *Water Research*, 42(15), 4206-4214

- Siddique, M. (2008) The Search for the Perfect Sensor to Monitor Hydrogen Sulfide;
International Gases & Instrumentation; November / December 2008
(<http://www.gasesmag-digital.com/gasesmag/20081112#pg24>)
- Thistlethwayte, D.K.B. (1972) The Control of Sulphides in Sewerage Systems; Ann
Arbor Science Publishers Inc.
- U. S. Environmental Protection Agency [EPA] (1974) Process Design Manual for Sulfide
Control in Sanitary Sewerage Systems; EPA 625/1-74-005; Cincinnati, Ohio
- U.S. Environmental Protection Agency [EPA] (1985) Design Manual: Odor And
Corrosion Control In Sanitary Sewerage Systems And Treatment Plants;
EPA/625/185/018; Cincinnati, Ohio
- Vollertsen J, Nielsen AH, Jensen HS, Wium-Andersen (2008) Corrosion of concrete
sewers -- the kinetics of hydrogen sulfide oxidation; Science of the Total
Environment 394, 162-170
- Vollertsen J; Revilla N, Hvitved-Jacobsen T; Nielsen AH, Jensen HS (2014) Modeling
Odors and Hydrogen Sulfide in the Sewers of San Francisco; Proceedings of the
conference Odors and Air Pollutants 2014, May 31 – June 3, 2014, Miami,
Florida
- Water Environment Federation [WEF] (2004) Control of Odors and Emissions from
Wastewater Treatment Plants; Manual of Practice 25; Alexandria, Virginia.
- Water Environment Research Foundation [WERF] (2007) Minimization of Odors and
Corrosion in Collection Systems Phase 1; Alexandria, Virginia.

- Yongsiri C.; Hvitved-Jacobsen T.; Vollertsen J.; Tanaka N. (2003) Introducing the emission process of hydrogen sulfide to a sewer process model (WATS); *Water Science and Technology* Vol. 47, No. 4, pp. 85-92; IWA
- Yongsiri, C.; Vollertsen, J.; Hvitved-Jacobsen, T. (2004a) Hydrogen sulfide emission in sewer networks: a two-phase modeling approach to the sulfur cycle; *Water Science and Technology* Vol. 50, No. 4, pp. 161-168; IWA
- Yongsiri C.; Vollertsen J.; Rasmussen, M.; Hvitved-Jacobsen T. (2004b) Air-water transfer of hydrogen sulfide: an approach for application in sewer networks; *Water Environment Research* 76 (1), January/February 81-88
- Yongsiri C.; Vollertsen J.; Rasmussen, M.; Hvitved-Jacobsen T. (2005) Influence of Wastewater Constituents on Hydrogen Sulfide Emission in Sewer Networks *Journal of Environmental Engineering*, Vol. 131, No. 12