

University of New Mexico
UNM Digital Repository

Health, Exercise, and Sports Sciences ETDs

Education ETDs

8-27-2009

Effect of Palm Temperature on Fatigue During High Intensity Bench Press Exercise

Young Sub Kwon

Follow this and additional works at: https://digitalrepository.unm.edu/educ_hess_etds

Recommended Citation

Kwon, Young Sub. "Effect of Palm Temperature on Fatigue During High Intensity Bench Press Exercise." (2009).
https://digitalrepository.unm.edu/educ_hess_etds/24

This Dissertation is brought to you for free and open access by the Education ETDs at UNM Digital Repository. It has been accepted for inclusion in Health, Exercise, and Sports Sciences ETDs by an authorized administrator of UNM Digital Repository. For more information, please contact disc@unm.edu.

Young Sub Kwon

Candidate

Health, Exercise, and Sports Sciences

Department

This dissertation is approved, and it is acceptable in quality and form for publication:

Approved by the Dissertation Committee:

 _____, Chairperson

 _____

 _____, Ph.D.

 _____

**EFFECT OF PALM TEMPERATURE ON FATIGUE DURING HIGH
INTENSITY BENCH PRESS EXERCISE**

BY

YOUNG SUB KWON

B.S., Physical Education, Chung-Ang University, 1997
M.S., Exercise Physiology, Chung-Ang University, 2001

DISSERTATION

Submitted in Partial Fulfillment of the
Requirements for the Degree of
Doctor of Philosophy

Physical Education, Sports, and Exercise Science

The University of New Mexico
Albuquerque, New Mexico

August, 2009

©2009, Young Sub Kwon

ACKNOWLEDGMENTS

I heartily acknowledge Dr. Suzanne Schneider, my advisor and dissertation chair, for continuing to encourage me through the years of classroom teachings and the long number of months writing and rewriting these chapters. Her guidance and professional style will remain with me as I continue my career. I aspire to someday reach your level of expertise in our field.

I also thank my committee members, Dr. Len Kravitz, Dr. Burke Gurney, and Dr. Christine Mermier, for their valuable recommendations pertaining to this study and assistance in my professional development. To Dr. Robert Robergs, thank you for your guidance and your excellent example of scientific curiosity. To Dr. Virginia Wilmerding, thank you for your enthusiastic support throughout my entire time here at UNM.

To my parents, Changrak Kwon and Younggi Shin, who gave me immeasurable support over the years. Your encouragement is greatly appreciated. To my three sons, Ohbyung, Ohseung, and Ohsoo, I do thank you from the bottom of my heart.

And finally to my wife, Min He Park, your love is the greatest gift of all.

**EFFECT OF PALM TEMPERATURE ON FATIGUE DURING HIGH
INTENSITY BENCH PRESS EXERCISE**

BY

YOUNG SUB KWON

ABSTRACT OF DISSERTATION

Submitted in Partial Fulfillment of the
Requirements for the Degree of

Doctor of Philosophy

Physical Education, Sports, and Exercise Science

The University of New Mexico
Albuquerque, New Mexico

August, 2009

Effect of Palm Temperature on Fatigue During High Intensity Bench Press Exercise

by

Young Sub Kwon

B.S., Physical Education, Chung-Ang University, 1997

M.S., Exercise Physiology, Chung-Ang University, 2001

**Ph.D., Physical Education, Sports, and Exercise Science,
University of New Mexico, 2009**

ABSTRACT

Local cooling, or cryotherapy can induce an ergogenic effect during short term intense exercise. One proposed method of personal cooling involves heat extraction from the palm using a device called the Rapid Thermal Exchanger (RTX). In this study we hypothesized that local palm cooling during rest intervals between progressive weight training sets will increase total repetitions and exercise volume in resistance trained subjects in a thermoneutral environment and that local palm heating will have no effect. Sixteen male subjects (mean±SD, age = 26±6 yr, height = 178±7 cm, body mass = 81.5±11.3kg, 1RM Bench press = 123.5±12.6 kg, % body fat = 10.3±5.4%, weight training experience = 10±6 yr) performed 4 sets of 85% 1RM bench press exercise to fatigue, with 3 min rest intervals. Exercise trials were performed in counterbalanced order on three days, separated by at least 3 days; Thermoneutral (TN), Palm Heating (PH), and Palm Cooling (PC). Heating and cooling were applied using the RTX set to 45 °C and 10 °C, respectively. Data were analyzed using 2-way repeated measures ANOVA and Tukey's post hoc tests. Total exercise volume (kg) during the 4 PC sets (2480±636) was

significantly higher than during TN (1972 ± 632) and PH (2156 ± 668) sets, ($p <.01$). The Root Mean Square (RMS) of the surface EMG from the lateral head of the triceps with PC exercise was higher ($p <0.01$), and heart rate and RPE were lower ($p <0.01$ and $p <0.05$, respectively) during PC compared to TN and PH. Palm cooling was associated with increased exercise repetitions and exercise volume, possibly related to a central fatigue response or to a peripheral counter-irritation effect. These results suggest that palm cooling may enhance training during progressive resistive exercise.

TABLE OF CONTENTS

Abstract.....	vi
LIST OF FIGURES	x
CHAPTER 3: RESEARCH MANUSCRIPT.....	x
LIST OF TABLES	xi
CHAPTER 2: REVIEW MANUSCRIPT.....	xi
CHAPTER 3: RESEARCH MANUSCRIPT.....	xi
CHAPTER I	1
Introduction	1
Problem Statement	5
Purpose of the Study.....	6
Hypotheses.....	6
Scope of the Study	10
Assumptions.....	11
Limitations	11
Significance of the Study.....	12
Definition of Terms.....	13
CHAPTER II.....	14
Effect of Local Cooling on Short-Term, Intense Exercise	15
SUMMARY	16
INTRODUCTION	17
LITERATURE.....	19
CONCLUSIONS.....	26
REFERENCES	27

CHAPTER III	38
Effect of Palm Temperature on Fatigue During High Intensity Bench Press Exercises	39
ABSTRACT	40
INTRODUCTION	41
METHODS	44
RESULTS	52
DISCUSSION	59
REFERENCES	65
CHAPTER IV	70
Summary: Hypotheses	70
Summary: Unique Contributions	71
Conclusions	72
Recommendations	72
LIST OF REFERENCES	73
LIST OF APPENDICES	80
APPENDIX A: INFORMED CONSENT	81
APPENDIX B: HEALTH HISTORY QUESTIONNAIRE	88
APPENDIX C: MODIFICATION OF THE CATEGORY RATIO RATING OF PERCEIVED EXERTION SCALE	92

LIST OF FIGURES

CHAPTER 3: RESEARCH MANUSCRIPT

Figure

1. Protocols for Warm-up, 1RM test, and 85% of 1RM 4 sets of bench press test
thermoneutral (TN), palm cooling (PC), and palm heating (PH) conditions.....46
2. Mean palm skin temperature response of the four 85% of 1RM sets of bench press test
during rest periods during thermoneutral (TN), palm cooling (PC), and palm heating
(PH) conditions.52
3. Repetitions during the four 85% of 1RM sets of bench press test during thermoneutral
(TN), palm cooling (PC), and palm heating (PH) conditions.53
4. Total exercise volume of the four 85% of 1RM sets of bench press test during room
temperature (TN), palm cooling (PC), and palm heating (PH) conditions.....54
5. Esophageal temperature (T_{es}) during baseline, rest periods, and 1 min after the 4th set
during the four 85% of 1RM sets of bench press test during thermoneutral (TN),
palm cooling (PC), and palm heating (PH) conditions.55
6. RPE response during the four 85% of 1RM sets of bench press test during
thermoneutral (TN), palm cooling (PC), and palm heating (PH) conditions.....56
7. Heart rate response of the four 85% of 1RM sets of bench press test during
thermoneutral (TN), palm cooling (PC), and palm heating (PH) conditions.....57
8. The mean difference (%) RMS of the eccentric and concentric contraction in the lateral
head of the triceps during the four 85% of 1RM sets of bench press test during room
temperature (TN), palm cooling (PC), and palm heating (PH) conditions.58

LIST OF TABLES

CHAPTER 2: REVIEW MANUSCRIPT

Table 1. Summary of various cooling methods used before and during short-term intensive isotonic exercise	32
Table 2. Summary of various cooling methods used before and during short-term intensive isokinetic exercise.....	33
Table 3. Summary of various cooling methods used before and during short-term intensive isometric exercise	34
Table 4. Summary of various cooling methods used before and during short-term intensive functional exercise.....	36

CHAPTER 3: RESEARCH MANUSCRIPT

Table 1. Characteristics of the participants (n=16).....	44
Table 2. The mean difference (%) RMS, MF, and MDF of the eccentric and concentric contractions during the four 85% of 1RM sets of bench press test during thermoneutral (TN), palm cooling (PC), and palm heating (PH) conditions (n=15).	59

CHAPTER I

Introduction

Muscle fatigue can be simply defined as the decrease in force development during repeated muscle contraction (Gibson & Edwards, 1985). Since the Italian physiologist Angelo Mosso (1846-1910) first discussed his findings on muscular fatigue in 1889 at the First International Congress of Physiologists held in Basel, Switzerland (Di Giulio et al., 2005), a remarkable volume of research has been published on this phenomenon. Dr. Mosso used a home-made ergograph for recording the force and frequency of flexion of the middle finger while raising one to four kilograms. His results indicated that individuals exhibit distinct fatigue curves during voluntary muscular contractions (Mosso, 1891). In addition, he showed that muscle contracted voluntarily and non-voluntarily had similar fatigue curves. He concluded that fatigue may be due to a peripheral phenomenon rather than to a central nervous system mechanism. Debate continues today about whether fatigue is caused by peripheral or central mechanisms (Noakes et al., 2004; Weir et al., 2006).

Research in the area of fatigue relating to physical activities has been based primarily on peripheral fatigue. Physical fatigue involves reductions in ability of muscle to perform work due to impairments along the chain of command between neuromuscular transmission and actin-myosin cross-bridging (Davis & Fitts, 1998). Potential mechanisms for peripheral fatigue include ATP and creatine phosphate depletion, metabolic acidosis (H^+ accumulation), hyperthermic fatigue, decreased blood glucose, low muscle glycogen stores, etc. Moreover, muscular fatigue mechanisms vary depending on the type, intensity, and duration of exercise. Because all these factors affect

muscular fatigue and depend on the muscle movement type, it is difficult to pinpoint precisely one cause for muscle fatigue. Central fatigue concerns factors that impair muscle force development that do not involve peripheral sites, thereby residing within the central nervous system (CNS). Some researchers hypothesize there is a central fatigue mechanism that is triggered by lowered blood glucose. If blood glucose is better maintained during prolonged exercise, such as after carbohydrate supplementation, then central fatigue is delayed. However, central fatigue may also exist during short-term, intensive exercise such as resistance training. This type of muscular fatigue is at least partially caused by an impairment of neural mechanisms (with a CNS contribution). Each motor nerve activates a group of muscle fibers, collectively referred to as a motor unit. The chemical messengers, or neurotransmitters, that carry the nerve's excitation to the muscle must cross the neuromuscular junction, and this process may become impaired during intense exercise. Decreased release or reduced post-receptor binding of the neurotransmitter may result in a decreased efficiency of the muscle fiber to contract (Gardiner, 2000).

Ergogenic supplementations such as caffeine and creatine phosphate have been studied and found to delay fatigue. Caffeine can stimulate the CNS to increase alertness, concentration, and vigor, and it may increase maximal motor unit recruitment (Williams, 1991), which is important during intense exercise. However, the drawbacks for ingestion of caffeine are that it is addictive, increases the incidence of cardiac arrhythmias, and has a mild diuretic function (Neuhäuser-Berthold, et al., 1997), which may contribute to dehydration inhibiting sustained exercise performance. During short term high intensity exercise, performance is influenced by the store of creatine phosphate in the muscle.

Creatine ingestion can improve high intensity exercise performance such as weight lifting (Volek et al, 1997). However, excess creatine may be an unhealthy burden on the kidneys (Silber, 1999). Although there is less concern today than there used to be about possible kidney damage from creatine, patients with kidney disease should avoid use of this supplement. This risk may be present even when creatine supplementation is used at maintenance doses. If a patient has renal disease, creatine may worsen renal function and glomerular filtration (Yoshizumi & Tsourounis, 2004).

Several researchers (Verducci, 2000; Burke et al., 2000) have reported that local cooling produces an ergogenic effect during short and intense resistive exercise. Verducci (2000;2001) suggested that one possible way to decrease muscular fatigue or increase the weight lifted during weight training is to apply cryotherapy (cold therapy) to the skin surface above the exercising muscle during rest periods between sets. Traditionally, cryotherapy is used in a rehabilitation situation, but it has also been considered to produce an ergogenic effect in the athlete (Knight, 1995; Burke, et al., 2000; Verducci, 2000; 2001). Verducci (2000; 2001) discussed that the rationale of cryotherphy was an immediate conduction heat loss, the temperature closer to the optimal work temperature and causing pain reduction.

Clarke et al. (1958) reported that more work is accomplished when the muscle temperature is lower than normal. However, muscle temperature increases rapidly when exercising with high intensity (Nielsen & Nielsen, 1962). If the athlete stays cool during exercise, less blood is shunted to the skin for heat dissipation, making more blood available to perfuse working muscles with delivery of oxygen and nutrients and removal of metabolic products. Some investigators reported that local cooling has a positive effect

on force production (Cornwall, 1994, Kimura & Gulick, 1997; Burke et al., 2000; Vaducci 2000& 2001). Palmieri-Smith et al. (2007) concluded that ankle joint cooling increased local muscle reflex, muscle excitability, and short-term release of neurotransmitters from the central nervous system. These phenomena suggested that local cooling may enhance motor neuron output. In addition, anesthesia (from the Greek for “without feeling”) resulting from cryotherapy is an important positive aspect associated with exercise. An increased pain receptor threshold produced by cryotherapy might enable an athlete to produce greater force with less pain or discomfort (Knight 1995).

However, the effects of cryotherapy on local muscle function remain controversial. Negative effects of cooling may be related to either the cooling method or the cooling surface. The cooling methods used in many studies have included cold or ice water baths, gel packs, or plastic bags with ice cubes and periods of cooling from 10 to 45 minutes (Mattacolar and Perrin, 1993; Ruiz et al, 1993, Cornwall, 1994; Howard et al., 1994; Hatzel and Kaminski, 2000; Douris et al., 2003). These researchers applied cooling immediately before exercise to examine the effect of muscle temperature on neuromuscular function during exercise, rather than to induce an ergogenic effect. To improve muscle strength, it is beneficial to raise muscle temperature before exercise. Asmussen and Boje (1945) reported that warm-up sets to increase muscle temperature before exercise improves muscle strength. Therefore, pre-cooling before exercise will decrease muscle performance. Cooling during exercise on the other hand, may prevent a rise in body temperature during exercise yet allow the warm-up benefit. Another negative effect of cooling on muscular performance may relate to the cooling surface. Most of the previous studies applied cooling to the skin over the exercising muscle. Other researchers

(Hopkins et al., 2006; Palmieri-Smith et al., 2007) cooled the joint closest to the exercising muscle. Each of these studies showed an increase in muscle motor recruitment with cooling during the exercise.

One proposed method of personal cooling involves heat extraction from the palm using a device called the Rapid Thermal Exchanger (RTX). The RTX is a relatively new cooling device that takes advantage of the anatomical structure of the palms to apply heating or cooling. The arteriovenous anastomoses (AVAs) and venous plexuses in the palms of the hands are effective mechanisms for heat exchange (Guyton, 2000). The RTX is small and portable and may provide a practical method for local cooling during weight training. This cooling device applies 35-to 45-mmHg subatmospheric pressure around the hands to oppose cold reflex vasoconstriction of the AVAs. The RTX has been shown to reduce exercise-induced hyperthermia in individuals with spinal cord injury (Hagobian et al., 2004) and with multiple sclerosis (Grahn et al., 2008) and to improve aerobic exercise endurance in a hot environment (Grahn et al., 2005; Hsu et al, 2005). Anecdotally, the RTX has been reported to enhance an athlete's work capacity during strength training, especially when the athlete is working at near maximum performance levels. However, there are no published findings to support these individual observations.

Problem Statement

There have been inconsistent observations that local cooling might enhance muscle strength and endurance. It is unknown whether this effect might occur through a delayed central fatigue or through a peripheral counter-irritation effect. Further

understanding of this phenomenon might increase the knowledge about mechanisms of muscular fatigue during repeated intense resistance exercise contractions.

Purpose of the Study

This investigation was undertaken to determine if there are significant differences in muscular endurance and neurological measurements, as well as subjective perceptions of fatigue when a trained individual performs sets of high intensity, isotonic exercise (bench press) with different temperatures applied to the hands during the rest periods between sets. The measurements in this study include assessment of total work volume, EMG recordings, esophageal temperature, palm skin temperature, heart rate, and subjective perceptions of fatigue.

Hypotheses

The following hypotheses were tested in this study.

Hypothesis I.

Total work volume during multiple sets of high intensity bench press exercise will be affected by temperature applied to the hand during the rest periods between sets.

- A. Without cooling or heating between sets (only negative pressure), total work volume (load lifted x reps) will decrease with each successive set of high intensity (85% of 1RM) bench press exercise with 3 min periods of rest between sets.
- B. A short period of hand cooling (10°C) with negative pressure will increase the total work volume of high intensity bench press exercise during set two, more

than set one. Total work volume during sets 2-4 will be greater with cooling than during a thermoneutral trial.

- C. A short period of hand heating (45°C) with negative pressure will have no effect on the total work volume of high intensity bench pressure exercise. Total work volume during sets 2-4 will be similar to the thermoneutral condition during each set.

Rationale. Several researchers (Verducci, 2000; Burke et al., 2000; Knight, 1995) have reported that local cooling produces an ergogenic effect during short and intense resistive exercise. Verducci (2000; 2001) suggested that one possible way to decrease fatigue and increase the weight lifted during weight training is to apply cryotherapy (cold therapy) to the skin surface above the exercising muscle during rest periods between sets. Cooling may improve muscle performance because less blood is shunted to the skin for heat dissipation, making more blood available to perfuse working muscles. Alternately, cooling may increase local muscle reflex, muscle excitability, and short-term release of neurotransmitters from the central nervous system (Hopkins et al., 2002; Palmieri-Smith et al., 2007). These phenomena suggest that local cooling may enhance motorneuron output. If hand cooling affects the central arousal response, then the repetitions of the 2nd set should be higher than 1st, 3rd, and 4th set and total work would be more than the thermoneutral trials. Although increased body temperature using warm-up is thought to be of benefit to short-term intense exercise performance (Asmussen & Boje, 1945), since warm-up sets and a 1st set to fatigue was done in all conditions, the addition of heat stress to exercise will be a limiting factor. In addition, the heating would not cause an arousal or

analgesic effect and therefore most likely would not have any effect on total work volume under these conditions.

Hypothesis II.

Cooling the hands between sets alters the EMG response during exercise. The EMG analyses will be performed from data collected during both eccentric and concentric movements. The surface EMG signals during the first contraction of the 1st set of 85% 1RM will be compared to the last contraction of the 4th set of 85% of 1RM to assess the changes that occur due to fatigue, under the three temperature conditions.

- A. Cooling the hands between sets will increase the Root Mean Square (RMS) (an index of muscle fiber recruitment) of the EMG compared to thermoneutral and heating conditions or may allow more repetitions to occur with a similar final RMS.
- B. Cooling the hands between sets will decrease or maintain the Mean Frequency (MF) (an index of muscle fatigue) and the Median Frequency (MDF) (another index of muscle fatigue) of the EMG compared to the thermoneutral and heating conditions or cooling may allow more repetitions to occur with similar final MF and MDF values.

Rationale. Muscular fatigue is reflected by specific changes in an EMG recording in the time (RMS) or frequency (MF and/or MDF) domains (Edwards, 1981). An increase in RMS might reflect greater total muscle fiber recruitment for a fixed submaximal external force (Edwards, 1981; Newham et al., 1983). For the frequency domain analysis of the EMG, the variable usually employed to assess fatigue is the MD and/or the MDF of EMG. While change in either MF or MDF may reflect decreases in muscle fiber

conduction velocity, synchronization of the motor units has been shown to occur during fatigue and cause a shift of MF towards lower frequencies (Bigland-Ritchie et al., 1981). These phenomena during fatigue are well documented for sustained isometric contractions (DeLuca, 1984). Although there has been debate about using these indices during dynamic contractions, recent studies indicate that these indices also may be valid during dynamic contractions (Sundelin & Hagberg, 1992).

Hypothesis III.

Core temperature, measured with an esophageal thermistor, will be reduced during cooling compared to the thermoneutral and heating conditions and be associated with a greater number of reps. Hand heating will increase core temperature compared to the thermoneutral and cold conditions and will be associated with no change in total reps.

Rationale. During aerobic exercise it has been reported that heat extraction from the palm improves endurance (Grahn et al., 2005). These researchers attributed the increase in endurance time to cardiovascular effects (larger stroke volume, enhanced muscle blood flow) caused by a lower core temperature. The rationale why they cooled the palms of the hands is that this area of the body has circulatory adaptations that enhance heat dissipation, despite the small surface area for cooling. Like the dog's tongue, rabbit's ear, and penguin's feet, these areas contain arterial venous anastomoses (AVAs) that can shunt blood directly from arterioles to venous plexuses, and act as heat radiators (Greenfield, 1963; Bergersen, 1993; Grahn et al, 1998). Previous studies reported that cooling these areas is an effective method of heat removal (Livingstone et al., 1989; 1995; Hagobian et al., 2003; Grahn et al., 2005; Hsu et al., 2005; Giesbrecht et al., 2007; Grahn et al., 2008; Khomenok et al., 2008). The rationale as to why they applied

subatmospheric pressure to this area during cooling is that it may enhance heat transfer by opposing a reflex vasoconstrictor response which would reduce perfusion of the AVAs during cooling. Heating the hands could result in vasodilation and transfer of heat to the body. With the high blood flow through the hands, despite the small surface area, there will be a rise in core temperature, but since a warm-up and 1st set were completed, there will be change in total reps before fatigue.

Hypothesis IV.

Heart rate and the subjective perception of fatigue using a rating of perceived exertion (RPE) scale will be reduced during sets 2-4 in the cooling condition compared to the thermoneutral and heating conditions.

Rationale.

Cooling-induced analgesia may increase pain receptor threshold (Knight, 1995). It may thus allow a greater muscular force during high intensity consecutive sets of bench press exercise. Therefore, cooling may function as a pain killer, reducing the sensation of fatigue. Day et al. (2004) showed that the RPE method is a reliable and useful tool during resistance training. If cooling functions as a pain killer, reducing the sensation of fatigue will reduce the subjective perception of fatigue during sets 2-4 of cooling, compared to the thermoneutral and heating conditions.

Scope of the Study

This study was designed to assess the effect of hand cooling on muscle performance during isotonic muscle contractions, esophageal temperature, EMG, heart rate and the perception of fatigue in trained people. Sixteen volunteers were recruited

from the student population of the university and athletes from the local community. The male subjects were apparently healthy individuals who did resistance training at least 3 sessions/week for the past year, attained the 80th percentile of a ratio of bench press weight/ body weight, and were less than 40 years of age.

Assumptions

The following assumptions were made:

1. Subjects followed specific guidelines given to them, e.g., we assume they refrained from CNS stimulating supplementation such as coffee and tea during test days.
2. Cooling of the hands will be sufficient to produce an ergogenic effect. 10°C was the lowest temperature setting of the RTX.
3. The work/rest protocol will allow sufficient time for cooling to see an effect.
4. We assume that subjects were honest when they completed the health history and physical activity level questionnaire.

Limitations

This study was subject to the following limitations:

1. This study included only bench press as a representative exercise of upper body exercise.
2. Only male subjects were recruited. Endogenous changes in sex hormones in women may have altered their baseline body temperature and complicated

interpretation of data in this study protocol. Therefore these results can apply only to men.

3. This study included hand cooling as well as subatmospheric pressure. The equipment used in this study is intended to be used with the vacuum function to maximize blood flow and therefore enhance heat exchange to palm of the hands. Cooling the palms without negative pressure may not produce the same results.

4. The EMG fatigue response during isometric contractions has been extensively reported; however, EMG during isotonic contractions has not been thoroughly examined.

5. A metronome was not used during bench press, allowing the lifting time to gradually increase during each set. This must be accounted for in the interpretation of the data.

6. The subjects were well-trained people, so it is difficult to generalize our results to less trained subjects.

7. Only one method of cooling was tested.

Significance of the Study

It is important to find ways to reduce fatigue in critical tasks and situations. Trainers of athletes, coaches, strength and conditioning specialists and personal trainers can use this protocol to enhance training results in their athletes and customers. There also may be applications of these results for occupational and military settings.

Definition of Terms

The terms in this study have been operationally defined as follow:

Muscular fatigue. The inability to continue exercise at a given intensity

Central muscular fatigue. Fatigue caused by changes in the central nervous system processing and execution of motor patterns.

Peripheral muscular fatigue. The mechanisms of fatigue within the muscle.

RTX. The Rapid Thermal Exchange which takes advantage of the anatomical structure of the palms to apply heating or cooling and applies negative pressure to maximize skin perfusion.

Arousal. A physiological and psychological state of being alert and awake. It involves the activation of the reticular activating system in the brain stem, the autonomic nervous system and the endocrine system, leading to increased heart rate and blood pressure and a condition of sensory alertness, mobility and readiness to respond.

Norepinephrine. A neurotransmitter in the catecholamine family that mediates chemical communication in the sympathetic nervous system.

Cryotherapy. Cold therapy which includes ice pack therapy that is used for the application of an ice pack (typically a plastic bag filled with ice) is commonly used to treat pain conditions.

1 RM. Maximum weight that cannot be lifted more than one time.

CHAPTER II

This Chapter presents a review manuscript written for submission to the Journal of Strength and Conditioning Research. The references cited in this review are provided at the end of the manuscript.

A REVIEW: Effect of Local Cooling on Short-Term, Intense Exercise

By

**Young sub Kwon¹, Robert A. Robergs^{1,2}, Len R. Kravitz¹, Burke A. Gurney³,
Christine M. Mermier¹, Suzanne M. Schneider¹**

¹Department of Health, Exercise & Sports Sciences, University of New Mexico, New Mexico, U.S.A.; ²School of Biomedical and Health Science, University of Western Sydney, Sydney, Australia. ³Department of Orthopaedics and Rehabilitation, University of New Mexico School of Medicine, New Mexico, U.S.A.

Running title: Local Cooling and Exercise

Address for Correspondence:

Young Sub Kwon

University of New Mexico

Exercise Physiology Laboratory

Department of Health, Exercise and Sports Sciences

MSC 04 2610

Albuquerque, NM 87131-0001

Phone: (505) 277-2658; Fax: (505) 277-9742; Email: ykwon@unm.edu

SUMMARY

The widespread belief that local cooling impairs short-term, strenuous exercise performance is controversial. Twenty-one original investigations involving cooling before short-term, intensive exercise are summarized in this review, and intermittent local palm cooling is introduced as a useful method to enhance this kind of exercise. Previous literature examining short-term intensive exercise and local cooling primarily has been limited to the effects on performance immediately or within minutes following cold application. The literature related to the effect of interval local cooling before short duration, high intensity isotonic exercise such as weight lifting is limited. Most past researchers have failed to take into account the effects of tissue warm-up and re-warming muscles, which is an important factor during this type of exercise. Most previous cooling studies used more than 20 minutes of precooling, and found that cooling had a negative effect on strength, performance and fatigue. Because of the short duration, high intensity exercise requires an adequate warm-up session to prepare for optimal performance, and precooling is not a practical way to prepare for this type of exercise. One possible beneficial effect of local cooling may be pain reduction, by an “irritation effect” which blocks pain sensation. A relatively new cooling device, the Rapid Thermal Exchanger (RTX), may provide a practical method for intermittent local cooling during weight training. However, there are no published findings to support the effects of such a cooling strategy during exercise.

INTRODUCTION

Cryotherapy (cold therapy) is a well known component in the established management of acute musculoskeletal injuries (Knight, 1995). Trauma during games, practices, or rehabilitation exercise may require that cryotherapy be applied, usually for 20 to 30 minutes (Knight, 1995). In practice, the athlete is usually returned to play in a game or exercise after cooling application, such as when baseball pitchers put ice bags around their shoulder after every inning. Therefore, strength and endurance changes after cooling should be a concern of strength training specialists, athletic trainers or sports medicine professionals. Most traditional research concerning strength and endurance changes following cold application has involved isometric contractions. In the early 1980's Haymes and Rider (1983) began to study cooling before isokinetic contractions, and some researchers (Catlaw et al, 1996; Kimura & Gulick, 1997) found that cold application improved eccentric strength and endurance involving higher contraction speeds during isokinetic contractions. Functional performance after cooling application also has been studied; however, isotonic contractions like weight training have not been studied. In this review we summarized 21 original investigations that involved human studies using short-term, high intensity or functional exercises, not endurance exercise. We propose that application of interval cold exposure between exercise bouts may decrease muscle fatigue and improve the resistive exercise training response.

What is muscle fatigue?

Muscle fatigue can be defined as a decrease in force development during repeated muscle contraction (Gibson & Edwards, 1985). Since the Italian physiologist Angelo Mosso (1846-1910) first discussed his findings on muscular fatigue in 1889 at the First

International Congress of Physiologists (Di Giulio et al., 2005), a remarkable volume of research has been published on this phenomenon. Dr. Mosso used a home-made ergograph for recording the force and frequency of flexion of the middle finger while raising one to four kilograms. His results indicated that individuals exhibit distinct fatigue curves during voluntary muscular contractions (Mosso, 1891). In addition, he showed that muscle contracted voluntarily and non-voluntarily had similar fatigue curves and thus he concluded that fatigue may be due to a peripheral phenomenon rather than to a central nervous system mechanism. Debate continues today about whether fatigue is caused by peripheral or central mechanisms (Noakes et al., 2004; Weir et al., 2006).

Research in the area of fatigue relating to physical activities has been based primarily on peripheral fatigue. Physical fatigue involves reductions in ability of muscle to perform work due to impairments along the chain of command between neuromuscular transmission and actin-myosin cross-bridging (Davis & Fitts, 1998). Potential mechanisms for peripheral fatigue include ATP and creatine phosphate depletion, metabolic acidosis (H^+ accumulation), hyperthermic fatigue, decreased blood glucose, low muscle glycogen stores, etc. Moreover, muscular fatigue mechanisms vary depending on the type, intensity, and duration of exercise. Because all these factors affect muscular fatigue and depend on the muscle movement type, it is difficult to pinpoint precisely one cause for muscle fatigue. Central fatigue concerns factors that impair muscle force development that do not involve peripheral sites, thereby residing within the central nervous system (CNS). Some researchers hypothesize there is a central fatigue mechanism that is triggered by lowered blood glucose. If blood glucose is better maintained during prolonged exercise, such as after carbohydrate supplementation, then

central fatigue is delayed. However, central fatigue may also exist during short-term, intensive exercise such as resistance training. This type of muscular fatigue is at least partially caused by an impairment of neural mechanisms (with a CNS contribution). Each motor nerve activates a group of muscle fibers, collectively referred to as a motor unit. The chemical messengers, or neurotransmitters, that carry the nerve's excitation to the muscle must cross the neuromuscular junction, and this process may become impaired during intense exercise. Decreased release or reduced post-receptor binding of the neurotransmitter may result in a decreased efficiency of the muscle fiber's ability to contract (Gardiner 2000).

LITERATURE

This paper is a review of literature to assess the effects of cooling on muscular fatigue or performance. Relevant papers were identified and selected using Pubmed, searching journal articles and reference lists, and World Wide Web searches using Google Research search engine identifying key databases and online journals. We summarized 21 original investigations focused on human studies and short-term, resistive exercise and functional exercises, not cardio-respiratory endurance exercise. We limited our search to local cooling and short-term, high intensity exercise including isokinetic, isometric, isotonic, and function performance. Most local cooling and short-term, high intensity exercise studies involved athletes and healthy young subjects.

Findings

Table 1 to Table 4. summarize studies using various methods of short duration, high intensity exercise. Most of these studies applied local cooling rather than whole

body cooling. A number of factors influenced the performance results: type of cooling method, site of cooling, size of the body region cooled, duration of cooling, and exercise type and protocol. Predominantly, studies evaluating precooling have used cold water immersion; however, the range of water temperatures used for cooling was quite wide (1~13°C).

Cooling studies which found increased fatigue or decreased strength and performance

Mattacola and Perrin (1993) reported a reduction in concentric dorsiflexion strength after 15°C water immersion for 20 minutes before exercise. Hatzel and Kaminski (2000) found similar results, that concentric dorsiflexion strength in the ankle was adversely affected immediately after lower leg ice immersion. Howard et al (1994) assessed isokinetic knee extension strength at 30, 180, 300 and 400°/sec and isometric strength after 12°C water immersion up to gluteal fold. In this study, average peak torque, the power and total work were reduced only at the higher velocities (180, 300 and 400°/sec). No significant changes in strength were observed for isometric force or at the lower velocity movements (0 and 30°/sec). Douris et al. (2003) found that precooling by immersing the hand in 10 °C cold water for durations between 5 and 20 minutes decreased isometric maximal grip strength and delayed the subsequent recovery of grip strength. Cross et al. (1996) reported decreases in vertical jump performance and shuttle run after ice immersion (13°C) for 20 minute of the lower legs. These authors tested 20 male subjects from soccer and football university teams. Richendollar et al. (2006) tested active male subjects and reported that application of ice bags with compression on the anterior thigh for 20 minutes negatively affected their performance of maximal, high-

intensity functional tests. However, active warm-up after cold application decreased the detrimental effect of icing on functional performance but did not restore performance to the level found without cooling and with warm-up. Cross et al. (1996) and Richendollar et al. (2006) tested different subject populations (male athletes vs. active males); however, they found similar performance decrements. Most recently Fischer et al. (2009) reported similar results as Cross et al. (1996) and Richendollar et al. (2006) after they cooled the hamstrings. Fisher et al (2009) reported that a 3-minute ice bag application had no effect on functional performance. Based on the findings from these authors, 10 minutes or more of cooling reduces performance due to an effect of cold application on reduced muscle contractility and decreased nerve conduction velocity.

Mechanisms whereby temperature might increase fatigue

Generally, immersion in cold water (5°C ~ 15°C) has been shown to decrease the force generating capability of skeletal muscle (Davis & Young, 1983; Mattacola & Perrin, 1993; Catlaw et al, 1996; Cross et al., 1996; Hatzel & Gulick, 2000; Douris et al., 2003; Thornley et al, 2003; Richendollar et al; 2006; Patterson et al; 2008; Fisher et al., 2009). These cold-induced performance decrements have been attributed to a variety of factors. At lower temperatures, longer times are required for deactivation (Marsh, 1990), nerve conduction velocity is reduced (Montgomery & Macdonald, 1990) and the motor unit recruitment order is compressed (Rome, 1990). When temperatures are lower than the point where the viscosity of the sarcoplasm and muscle increase, there will be resistance to the cross-bridge formation (Clarke et al., 1958). In addition, precooling is often applied to the legs, so if a subject puts her/his leg in cold water, then the agonist as well as the antagonist muscle viscosity increases. This may further explain why primarily

high-speed concentric force production is decreased (Howard et al., 1994). Kössler et al. (1987) and Ranatunga and Wylie (1989) suggested that cooling reduces the release of Ca^{+2} from the sarcoplasmic reticulum resulting in a decline in ATP turnover, which impairs cross-bridge formation. Most of the studies used more than 10 minutes of precooling and found a negative effect on strength, performance and fatigue. Because short duration, high intensity exercises requires a warm-up for optimal performance, precooling is not a practical way to prepare for this kind of exercise.

Studies that cooled muscle to reduce fatigue or increased strength and performance

Clarke et al (1958), Christensen & Mohamed (1984), Catlaw et al. (1996), Kimura & Gulick (1997), Verducci (2000;2001), and Burke et al. (2000) reported that cooling can decrease muscle fatigue and increase strength. These studies involved isometric, isokinetic and isotonic muscle contraction exercises. There are no studies that have cooled muscle to reduce fatigue or increase functional performance. Most investigations in table 2 to 4 used a minimum of more than 10 minutes of cooling before exercise. However, the studies with positive results used only 3 minutes of pre-cooling (Verducci, 2000; 2001; Catlaw et al, 1996; Kimura & Gulick, 1997; Burke et al, 200) or 10 minutes of cooling during exercise. Although Clarke et al. (1958) and Christensen & Mohamed (1984) used a longer cooling duration (30 min), Clarke et al (1958) used a relatively warmer water temperature (18°C) and Christensen & Mohamed cooled the cheek to measure the MVC motor activity and did not assess performance. Interestingly, most of these positive studies used precooling. However, Verducci (2000; 2001) applied cooling between sets, so his subjects already had warmed up their body and muscles and already had completed the first set of exercise. This is a more practical method to cool the body

to increase exercise performance. This study first used cooling during weight training, between multi-sets, to improve muscle performance. Cooling between sets increased the total work completed (number of pulls and total joules), supporting the concept of cooling during exercise as a potential ergogenic aid. The results of Yanagisawa et al. (2003) investigated the effect of the lower leg 15°C water immersion after strenuous resistance training. They did not measure performance but intracellular pH level. Their most important finding was that cooling after the ankle plantar flexion exercise (12 repetitions, 5 sets) caused an increase in intracellular pH, which may have enhanced muscle recovery after exercise. Some researchers (Catlaw et al., 1996; Kimura & Gulick, 1997) showed a positive effect of local cooling on eccentric performance during isokinetic contractions. Catlaw et al. (1996) reported an increase in eccentric strength at high contraction velocity (175 and 200°/sec). Kimura & Gulick (1997) reported that precooling increased eccentric total work (endurance). Burke et al. (2000) trained 45 subjects for five consecutive days. Subjects completed 1 set of 4 isometric contractions of hip extension under three treatment conditions (thermoneutral, hot and cold water immersion up to gluteal fold). They found an increase in maximum isometric force production in the cold group ($8\pm 1^{\circ}\text{C}$) compared to the thermoneutral and hot group ($43\pm 1^{\circ}\text{C}$). They concluded that thermotherapies (both hot and cold) are important to muscular performance because both therapies have positive effects on the rate of recovery. Although there was only a five day training period in this study, the results showed a potential training effect of cryotherapy. The authors suggested that the cooled subjects attained greater daily maximal isometric contractions and therefore they were able to train at a greater workload each day.

Mechanisms by which cooling might reduce fatigue

The basis of the precooling strategy is to reduce body temperature before long duration exercise, thereby increasing the reserve for metabolic heat production and increasing the time before reaching a critical limiting temperature where a given exercise intensity can no longer be maintained (Marino, 2002). However, some researchers suggested that local cooling increases muscular performance due to impaired sensory perception (Holewijn et al., 1992; Ruiz et al., 1993) and pain reduction (Christenson & Mohamed, 1984; Catlaw et al., 1996; Kimura & Gulik, 1997; Burke et al., 2000; Verducci, 2000; 2001). Cooling can induce local analgesia (Prentice, 1982) which is an important positive aspect associated with rehabilitation. It can increase pain receptor thresholds, allowing strengthening exercises. Christenson and Mohamed (1984) reported that ice cooling for 30 minutes increased MVC motor activity in the masseter muscle. They presumed that increased alpha motor activity in the cooled masseter muscle might have resulted from motor facilitation that was mediated by cold receptors, or it might be due to the absence of pain and fatigue. Burke et al. (2000) also proposed a positive aspect of analgesia during rehabilitation. They suggested that increased pain receptor thresholds and decreased perception of contraction intensity allowed greater strength and force output without pain sensation. Therefore, it is possible to exercise with higher intensity after precooling. Other researchers (Catlaw et al., 1996; Kimura & Gulick, 1997) suggested that decreased muscle spindle activity and decreased nerve conduction velocity allowed the muscle to generate more tension during eccentric contractions. Increased muscle viscosity, a negative aspect of cooling, allowed isokinetic eccentric contractions at higher speed. In addition, a change in muscle recruitment order can increase eccentric

endurance (total work) because cooling increases slow twitch fiber recruitment, which allows less immediate activation of the fast twitch fibers allowing them to contract longer before fatigue. Verducci (2000; 2001) was one of the first to apply cooling during exercise to improve performance. He first allowed the muscle temperature to rise by not applying cooling immediately. Clarke et al. (1958) previously had shown that when muscle temperature was around 27°C, the duration of exercise was longest compared to muscle temperatures below or above 27°C. Since muscle temperature increases rapidly at the start of exercise (Nielsen & Nielsen, 1962), Verducci's intention was not cool the muscle but to increase muscular endurance by preventing a rise in temperature. Therefore, he gave only 3 minutes of cooling. However, he gave another 5 minutes of passive rewarming after the 3 minutes of local cooling because he wanted his study results and protocol to be relevant to baseball pitchers.

Practical applications for resistance exercise training

To optimize muscle strength during training one must first raise muscle temperature before exercise. Asmussen and Boje (1945) reported that warm-up sets prior to exercise improve muscle strength. Cooling during exercise on the other hand, may prevent a further rise in body temperature which has a detrimental effect on exercise endurance. Therefore, a warm-up followed by cooling during exercise might be the best to optimize muscle temperature and optimize training responses. Another important aspect of cooling to improve muscular performance may relate to the cooling surface. Most previous studies using cooling applied to the skin over the exercising muscle. Other researchers (Hopkins et al., 2006; Palmieri-Smith et al., 2007) cooled the joint closest to the exercising muscle. Each of these studies found an increase in muscle motor

recruitment. One proposed method of personal cooling before upper body weight training involves cooling the hand. The arteriovenous anastomoses (AVAs) and venous plexuses in the palms of the hands and the feet make these effective sites for heat exchange (Guyton & Hall, 2000). Cooling the feet has been shown to reduce exercise-induced hyperthermia in individuals with spinal cord injury (Hagobian et al., 2004). Palm cooling has been shown to improve physical performance in heat-sensitive individuals with multiple sclerosis (Grahn et al., 2008) and to improve aerobic exercise endurance in a hot environment (Grahn et al., 2005; Hsu et al., 2005). The palm cooling may provide a practical method for local cooling in the weight room.

CONCLUSIONS

- Muscle fatigue varies with muscle temperature. This can be due to influences on both central and peripheral fatigue.
- Researchers who have studied precooling for more than 20 minutes, and cold water immersion (0~13°C) have found that such cooling decreases exercise performance.
- Acute local cooling can stimulate CNS.
- Cooling during exercise may limit the rise in muscle temperature and increase performance.
- When doing short and intense exercises like strength training or functional training, local cooling maybe applied after the warm-up or between sets of exercise to increase training volume.
- Local cooling can be applied over a joint or the palms instead of over the exercising muscle.

- Intermittent (interval) local cooling may be a new practical method to improve training efficiency for higher intensity, short-duration exercise.

REFERENCES

1. Asmussen, E. and Boje, O. Body temperature and capacity for work. *Acta Physiol Scand* 10: 1-22, 1945.
2. Burke, DG, Macneil, SA, Holt, LE, Mackinnon, NC, and Rasmussen, RL. The effect of hot or cold water immersion on isometric strength training. *J Strength Cond Res* 14: 21-25, 2000.
3. Catlaw, K, Arnold, BL, and Parin, DH. Effect of cold treatment on the concentric and eccentric force velocity relationship of the quadriceps. *Isokinet and Exerc Sci* 5: 157-160, 1996.
4. Clarke RSI, Hellon, RF, and Lind, AR. The duration of sustained contractions of the human forearm at different muscle temperatures. *J Physiol (London)* 143: 454-473, 1958.
5. Cornwall, MW. Effect of temperature on muscle force and rate of muscle force production in men and women. *J Orthop Sports Phys Ther* 20: 74-80, 1994.
6. Cristensen, LV, and Mohamed, SE. Effects of topical cooling on isometric contractions of the human masseter muscles. *Arch oral Biol* 29: 635-639, 1984.
7. Cross, KM, Wilson, RW and Perrin, DH. Functional performance following an ice immersion to the lower extremity, *J Athl Train* 31: 113-116, 1996.
8. Davies, CTM, Mecrow, LL, and White, MJ. Contractile properties of the human triceps surae with some observation on the effects of temperature and exercise. *Eur J Appl Physiol* 49: 255-269, 1982.
9. Davies, CTM, and Young, K. Effects of temperature on the contractile properties and muscle power of triceps surae in humans. *J Appl Physiol* 55: 191-195, 1983.
10. Davis, JM, and Fitts, R. Mechanisms of muscular fatigue. In: Roitman JL, ed. ACSM's resource manual for guidelines for exercise testing and prescription. Baltimore: Williams & Wilkins, 1998. pp. 182-188.
11. Di Giulio, C, Daniele, F, and Tipton, CM. Angelo Mosso and muscular fatigue: 116 years after the first congress of physiologists: IUPS commemoration. *Adv Physiol Educ* 30: 51-57, 2006.

12. Douris, P, Mckenna, R, Madigan, K, Cesarski, B, Costiera, R and Lu, M. Recovery of maximal isometric grip strength following cold immersion. *J Strength Cond Res* 17: 509-513, 2003.
13. Evans, TA, Ingersoll, C, and Knight, KL. Agility following the application of cold therapy. *J Athl Train* 30: 231-234, 1995.
14. Fischer, J, Van, BL, Branch, JD, and Pirone, JL. Functional performance following an ice bag application to the hamstrings. *J Strength Cond Res* 23: 44-50, 2009.
15. Gibson, H, and Edwards, RH. Muscular exercise and fatigue. *Sports Medicines* 2: 120-32, 1985.
16. Grahn, DA, Cao, VH, and Heller, HC. Heat extraction through the palm of one hand improves aerobic exercise endurance in a hot environment. *J Appl Physiol* 99: 972-978, 2005.
17. Grahn, DA, Murray, JV, and Heller, HC. Cooling via one hand improves physical performance in heat-sensitive individuals with multiple sclerosis: a preliminary study. *BMC Neurology* 12: 8-14, 2008.
18. Guyton, AC, and Hall, JE. The Textbook of Medical Physiology (10th ed.). Philadelphia, PA: W.B. Saunder, 2000.
19. Hagobian, TA, Jacobs, KA, Kiratli, BJ, and Friedlander, AL. Foot cooling reduces exercise-induced hyperthermia in men with spinal cord injury. *Med Sci Sports Exerc* 36: 411-417, 2004.
20. Hatzel, BM, and Kaminski, TW. The effect of ice immersion on concentric and eccentric isokinetic muscle performance in the ankle. *Isokinet and Exerc Sci* 8: 103-107, 2000.
21. Haymes EM, and Rider, RA. Effects of leg cooling in peak ioskinetic torque and endurance. *AM Corr Ther J* 37: 109-115, 1983.
22. Holewijn, M, and Heus, R, Effects of temperature on electromyogram and muscle function. *Eur J Appl Physiol Occup Physiol* 65: 541-545, 1992.
23. Hopkins, JT, Ingersoll, CD, Edwards, JE, and Klootwyk, TE. Cryotherapy and transcutaneous electric neuromuscualr stimulation decrease arthrogenic muscle inhibition of the vastus medialis following knee joint effusion. *J Athl Train* 37: 25-32, 2002.

24. Howard, RL, Kreamer, WJ, Stanley, DC, Armstrong, LE, and Maresh, CM. The effects of cold immersion on muscle strength. *J Strength and Cond Res* 8: 129-133, 1994.
25. Hsu, AR, Hagobian, TA, Jacobs, KA, Attallah, H, and Friedlander, AL. Effects of heat removal through the hand on metabolism and performance during cycling exercise in the heat. *Can J Appl Physiol* 30: 87-104, 2005.
26. Johnson, DG, Hayward, JS, Jacobs, TP, Collis, ML, Eckerson, JD, and Williams, RH. Plasma norepinephrine responses of man in cold water. *J Appl Physiol* 43: 216-20, 1977.
27. Kimura, IF, Gulick, DT, and Thmpson, GT. The Effect of Cryotherapy on Eccentric Plantar Flexion Peak Torque and Endurance. *J Athl Train* 32: 124–126, 1997.
28. Knight, KL. Cryotherapy in Sport Injury Management. Champaign, IL: Human Kinetics; 1995.
29. Kössler, F, Lange, F, and KÜchler, G. Isometric twitch and tetanic contraction of frog skeletal muscles at temperatures between 0 to 30 degrees C. *Biomed Biochim Acta* 46: 809-813, 1987.
30. Marino, FE. Methods, advantages, and limitations of body cooling for exercise performance. *Br J Sports Med* 36: 89-94, 2002.
31. Marsh, RL, Deactivation rate and shortening velocity as determinants of contractile frequency. *Am J Physiol* 259: 223-30, 1990.
32. McMaster, W. Crotherapy, *Phys Sports Med* 10: 112-119, 1982.
33. Mattacola, CG, and Perrin, DH. Effects of cold water application on isokinetic strength of the plantar flexors. *Isokin and Ex Sci* 3: 152–159, 1993.
34. Montgomery, JC, and Macdonald, JA. Effects of temperature on nervous system: implications for behavioral performance. *Am J Physiol* 259: 191-6, 1990.
35. Mosso, A. La Fatica. Milano: Treves, 1891.
36. Noakes, TD, St Clair Gibson, A. and Lambert, EV. From catastrophe to complexity: a novel model of integrative central neural regulation of effort and fatigue during exercise in humans. *Br J Sports Med* 38: 511-514, 2004.
37. Nielsen, B, and Nielson, M. Body temperature during work at different environmental temperatures. *Acta Physiol Scand* 56: 120-129, 1962.

38. Palmieri-Smith, RM, Leonard, JL, Garrison, JC, Weltman, AL, and Ingersoll, CD. Peripheral joint cooling increases spinal reflex excitability and serum norepinephrine. *International Journal of Neuroscience* 117: 229-242, 2007.
39. Patterson, SM, Undermann, BE, Doberstatein, ST, and Reineke, DM. The effects of cold whirlpool on power, speed, agility, and range of motion. *J Sp Sci Med* 7: 387-934, 2008.
40. Prentice, W.E. An electromyographic analysis of the effectiveness of heat or cold and stretching for inducing relaxing in injured muscle. *J Orthop Sports Phys Ther* 3:133-140, 1982.
41. Ranatunga, KW, and Wylie, SR. Temperature effects on mammalian muscle contraction. *Biomed Biochim Acta* 48: 530-5, 1989.
42. Richendollar, ML, Darby, LA, and Brown, TM. Ice bag application, active warm-up, and 3 measures of maximal functional performance. *J Athl Train* 41: 364-370, 2006.
43. Rome, LC. Influence of temperature on muscle recruitment and muscle function in vivo. *Am J Physiol* 259: 210-222, 1990.
44. Ruiz, DH, Myrer, JM, Durrant, E, and Fellingham GW. Cryotherapy and sequential exercise bouts following cryotherapy on concentric and eccentric strength in the quadriceps. *J Athl Train* 28: 320-323, 1993.
45. Salo, DC, Donovan, CM, and Davies, KJ. HSP70 and other possible heat shock or oxidative stress proteins are induced in skeletal muscle, heart, and liver during exercise. *Free Radic Biol Med* 11: 239-246, 1991.
46. Stinner, JN, and Hartzler, LK. Effect of temperature on pH and electrolyte concentration in air-breathing ectotherms. *J Exp Biol* 203: 2065-2074, 2000.
47. Thornely, LJ, Maxwell, NS, and Cheung, SS. Local tissue temperature effects on peak torque and muscular endurance during isometric knee extension. *Eur J Appl Physiol* 90: 588-594, 2003.
48. Verducci, FM. Interval cryotherapy decreases fatigue during repeated weight lifting. *J Athl Train* 35: 422-426. 2000.
49. Verducci, FM. Interval cryotherapy and fatigue in university baseball pitchers. *Res Q Exerc Sport* 72: 280-287. 2001.
50. Weir, JP, Beck, TW, Cramer, JT, and Housh, TJ. Is fatigue all in your head? A critical review of the central governor model. *Br J Sports Med* 40: 573-586, 2006.

51. Yanagisawa, O, Niitsu, M, Takahashi, H, Goto, K, and Itai, Y. Evaluations of Cooling Exercised Muscle with MR Imaging and ³¹P MR Spectroscopy. *Med Sci Sports Exerc* 35: 1517-1523, 2003.

TABLES

Table 1. Summary of various cooling methods used before and during short-term intensive isotonic exercise.

Subjects	Cooling method	Exercise protocol	Findings	Reference
10 club athletes	Ice packs for 3 minutes over arm and shoulder	75% of 1RM Cable arm pulling as fast as possible 22 times of four sets	Cryotherapy resulted in a significantly greater number of arm pulls and work volume	Verducci (2000)
6 division 2 baseball pitchers	The pitching arm was subjected to 3 minutes of icing	22 pitches in 8 min followed by an 8-min rest period	The icing condition delayed the onset of fatigue and generally increased velocity, with no differences in accuracy. Icing also reduced next day soreness.	Verducci (2001)

Table 2. Summary of various cooling methods used before and during short-term intensive isokinetic exercise.

Subjects	Cooling method	Exercise protocol	Findings	Reference
8 subjects	Cooling of thigh	Knee extension at 30, 180 and 300°/s	Not significant	Haymes & Rider (1983)
10 active male	The lower leg in a 15°C tub of water for 20 minutes	Concentric contraction of the plantar flexors	Precooling decreased peak torque, average power and total work.	Mattacola & Perrin (1993)
19 college male wrestlers	Plastic bag with ice for 25 minutes on the right quadriceps	Extension and flexion of the right knee at 60°/s	Precooling decreased both concentric and eccentric strength	Ruiz et al. (1993)
10 active male college students	Water immersion cold treatment (12°C) up to Gluteal fold	Knee extension at 30, 180, 300 and 400°/s	Precooling decreased average peak torque, power and total work at high velocity	Howard et al. (1994)
8 men and 8 women university athletes	An ice compression device (Cryo-cuff, Aircast) on the upper thigh for 20 minutes	Eccentric and concentric contractions of the quadriceps muscle from 10 to 90° of flexion at 25, 50, 75, 100, 125, 150, 175 and 200°/s	No significant difference in concentric contraction. Increase in eccentric strength at 175 and 200°/s	Catlaw et al. (1996)
11 male and 11 female subejets	A 30-minute 10°C ice the leg bath immersion to mid thigh	Knee extension at 30 and 120°/s and endurance at 120 °/s	Precooling increased eccentric total work, but had no effect on eccentric peak torque at either 30 or 120 °/s	Kimura & Gulick (1997)
12 college aged males	The dominant leg to tibial plateau was immersed at 10°C for 20 minutes	Plantar flexion and dorsi flexion, inversion, and eversion motions were assessed at speeds of 60°/s and 120°/s	Only contraction dorsiflexion strength in the ankle was adversely affected	Hatzel & Kaminski (2000)

Table 3. Summary of various cooling methods used before and during short-term intensive isometric exercise.

Subjects	Cooling method	Exercise protocol	Findings	Reference
4 healthy young men	Cold water over the forearm at between 2 and 42 °C for 30 min	Wrist extension	Contractions were longest in water at 18 °C (muscle temperature of about 27 °C)	Clarke et al. (1958)
5 healthy young subjects	Immersion in water (0°C until an 8.4°C decrease in muscle temperature) for both 30 min and 45 min (Water level 5cm distal to the greater trochanter)	Jump on the force platform and maximal 10-s work load on the bicycle ergometer	Increased in time to peak tension and half-relaxation time and decreased MVC.	Davis & Young (1983)
6 adult males	Ice applied to the right cheek for 30 min	Clenching for 10 and 80s at MVC	MVC motor activity increased. The cooled muscle caused no pain and fatigue.	Christensen & Mohamed (1984)
10 physically active male college students	Water immersion (12°C) to gluteal fold for 45 min, and thermal neutral treatment (35.5°C) for 45 min	Knee extension	Not significant	Howard et al. (1994)
18 healthy, right-hand dominant volunteers (9 males and 9 females)	Immersion of the right forearm in a cold (10°C), hot (40°C), and neither hot nor cold water bath immersion for 20 minutes	Wrist extension	Peak force and rate of force development decreased, while time to peak force development increased in males following exposure to cold. In females, the time to peak force development was increased by cold exposure	Cornwall (1994)
45 subjects from a college population (21 women and 24 men)	Cold water immersion up to Gluteal fold (8±1°C) for 10 min Hot water immersion (43±1°C) for 10 min	Hip flexion	Precooling increased maximum isometric force production. Men experienced a greater increase than women.	Burke et al. (2000)

16 healthy men	Submerge (10°C) the forearm for 5, 10, 15 and 20 min	Grip	Precooling decreased isometric grip strength and no recovery of this strength loss for 15 minutes	Douris et al. (2003)
9 trained males	A gel pack connected to a voltage source [starting gel pack temperature 55°C, 34°C, 22, and -17°C) on the anterior thigh muscle for 30 minutes.	Knee extension	MVC was not significantly affected by temperature Times to fatigue after both heating and warming were significantly shorter than after cooling.	Thornley et al. (2003)

Table 4. Summary of various cooling methods used before and during short-term intensive functional exercise.

Subjects	Cooling method	Exercise protocol	Findings	Reference
5 healthy young subjects	Immersion in water (46°C until a 3.1°C rise and 0°C until an 8.4°C decrease in muscle temperature) for 30 min and 45 min (Water level 5cm distal to the greater trochanter)	Jump on the force platform and maximal 10-s work load on the bicycle ergometer	Precooling decreased (43%) in jump power output and (32%) decrease in power output for cycling.	Davis & Young (1983)
24 male students	Foot and ankle Ice immersion for 20 min (1°C)	Co-contraction test, Shuttle run, and Carioca test	No difference in agility time.	Evans et al. (1995)
20 male subjects from soccer and football teams	Lower leg ice immersion (13°C) for 20 min	Shuttle run, the 6-m hop test, and the single-leg vertical jump,	Precooling decreased vertical jump scores and shuttle run times. Six-meter hop test values were not affected.	Cross et al. (1996)
24 active men, 18 to 24 years of age	Ice bag with compression immersion (13°C) on the anterior thigh for 20 min with warm-up (6.5 min) and without warm-up	Single leg vertical jump, agility shuttle Run, and 40 yard sprint	Ice bag application negatively affected performance on all functional tests.	Richendollar et al. (2006)
21 college-aged subjects	20 minute, 10 degree Celsius cold whirlpool to the fibular head	Counter movement vertical jump, T-test, 36.58-meter dash (40-yard), and active range of motion of the ankle	Participants demonstrated significant decreases in counter movement vertical jump, T-test, and 40-yard dash performance.	Patterson et al. (2008)

<p>42 (25 women, 17 men) recreational or collegiate athletes</p>	<p>3-minute ice bag application 10-minute ice bag application Ice bag treatments consisted of two plastic bags (28x46cm) one – third filled with cubed ice placed on the hamstring muscle belly</p>	<p>Shuttle run, Co-contraction test and Vertical jump</p>	<p>Shuttle run and vertical jump performances were impaired immediately after 10 minute ice bag application but not after 3 minute application.</p>	<p>Fischer et al. (2009)</p>
--	---	---	---	------------------------------

CHAPTER III

This chapter presents a research manuscript written for submission to Medicine & Science in Sports & Exercise. The references cited in this research manuscript are provided at the end of this chapter.

Effect of Palm Temperature on Fatigue During High Intensity Bench Press Exercise

Young sub Kwon¹, Robert A. Robergs^{1,2}, Len Kravitz¹, Burke A. Gurney³, Christine M. Mermier¹, Suzanne M. Schneider¹

¹Department of Health, Exercise & Sports Sciences, University of New Mexico, New Mexico, U.S.A.; ²School of Biomedical and Health Science, University of Western Sydney, Sydney, Australia. ³Department of Orthopaedics and Rehabilitation, University of New Mexico School of Medicine, New Mexico, U.S.A.

Running title: Palm Temperature and Reduction of Fatigue

Address for Correspondence:

Young Sub Kwon
University of New Mexico
Exercise Physiology Laboratory
Department of Health, Exercise and Sports Sciences
MSC 04 2610
Albuquerque, NM 87131-0001
Phone: (505) 277-2658
Fax: (505) 277-9742
Email: ykwon@unm.edu

ABSTRACT

Local cooling, or cryotherapy can induce an ergogenic effect during short term intense exercise. One proposed method of personal cooling involves heat extraction from the palm using a device called the Rapid Thermal Exchanger (RTX). **PURPOSE:** In this study we hypothesized that local palm cooling during rest intervals between progressive weight training sets will increase total repetitions and exercise volume in resistance trained subjects in a thermoneutral environment and that local palm heating will have no effect. **METHODS:** Sixteen male subjects (mean±SD, age = 26±6 yr, height = 178±7 cm, body mass = 81.5±11.3kg, 1RM Bench press = 123.5±12.6 kg, % body fat = 10.3±5.4%, weight training experience = 10±6 yr) performed 4 sets of 85% 1RM bench press exercise to fatigue, with 3min rest intervals. Exercise trials were performed in counterbalanced order on three days, separated by at least 3 days; Thermoneutral (TN), Palm Heating (PH), and Palm Cooling (PC). Heating and cooling were applied using the RTX set to 45°C and 10°C, respectively. Data were analyzed using 2-way repeated measures ANOVA and Tukey's post hoc tests. **RESULTS:** Total exercise volume (kg) during the 4 PC sets (2480±636) was significantly higher than during TN (1972±632) and PH (2156±668) sets, ($p < 0.01$). The RMS of the surface EMG with PC exercise was higher ($p < 0.01$), and heart rate and RPE were lower ($p < 0.01$ and $p < 0.05$, respectively) during PC compared to TN and PH. **CONCLUSION:** Palm cooling was associated with increased exercise repetitions and exercise volume, possibly related to a delayed central fatigue or to a peripheral counter-irritation effect. These results suggest that palm cooling may enhance training during progressive resistive exercise.

Key Words: ESOPHAGEAL TEMPERATURE, EMG, PALM COOLING, EXERCISE TRAINING, WEIGHT LIFTING

INTRODUCTION

Several researchers (Verducci, 2000; Burke et al., 2000) have reported that local cooling produces an ergogenic effect during short and intense resistive exercise. Verducci (2000) suggested that one possible way to decrease muscular fatigue or increase the weight lifted during weight training is to apply cryotherapy (cold therapy) to the skin surface above the exercising muscle during rest periods between sets. Traditionally, cryotherapy is used in a rehabilitation situation, but it has also been considered to produce an ergogenic effect in athletes (Knight, 1995; Burke et al., 2000; Verducci, 2000; 2001).

Clarke et al. (1958) reported that more work is accomplished when the muscle temperature is lower than normal. However, muscle temperature increases rapidly when exercising with high intensity (Nielson and Nielsen, 1962). Some investigators reported that local cooling has a positive effect on force production (Cornwall, 1994, Kimura & Gulick, 1997; Burke et al., 2000; Verducci 2000& 2001). Palmieri-Smith et al. (2007) concluded that ankle joint cooling increased local muscle reflex, muscle excitability, and short-term release of neurotransmitters from the central nervous system. These phenomena suggested that local cooling may enhance motorneuron output. In addition, analgesia resulting from cryotherapy is an important positive aspect associated with exercise. An increased pain receptor threshold produced by cryotherapy might enable an athlete to produce greater force with less pain or discomfort (Knight 1995).

However, the effects of cryotherapy on local muscle function remain controversial. Negative effects of cooling may be related to either the cooling method or the cooling surface. The cooling methods used in many studies have included cold or ice water baths,

gel packs, or plastic bags with ice cubes and periods of cooling from 10 to 45 minutes (Mattacolar and Perrin, 1993; Ruiz et al, 1993, Cornwall, 1994; Howard et al., 1994; Hatzel & Kaminski, 2000; Douris et al., 2003). These researchers applied cooling immediately before exercise to examine the effect of muscle temperature on neuromuscular performance. However, to improve muscle strength it is beneficial to raise body or muscle temperature before exercise. Asmussen and Boje (1945) reported that warm-up sets to increase body temperature prior to exercise improves muscle strength. Therefore, pre-cooling before exercise will decrease muscle performance. Cooling during exercise on the other hand, may slow the rise in body temperature during exercise yet allow the warm-up benefit. Another negative effect of cooling on muscular performance may relate to the cooling surface. Most of the previous studies using cooling applied cooling to the skin over the exercising muscle. Other researchers (Hopkins et al., 2006; Palmiei-Smith et al., 2007) cooled the joint closest to the exercising muscle. Each of these studies showed an increase in muscle motor recruitment.

One proposed method of personal cooling involves heat extraction from the palm using a device called the Rapid Thermal Exchanger (RTX). The RTX is a relatively new cooling device that takes advantage of the anatomical structure of the palms to apply heating or cooling. The arteriovenous anastomoses (AVAs) and venous plexuses in the palms of the hands are effective mechanisms for heat exchange (Guyton & Hall, 2000). The RTX is small and portable and may provide a practical method for local cooling during weight training. This cooling device applies 35-to 45-mmHg subatmospheric pressure around the hands to oppose cold reflex vasoconstriction of the AVAs. The RTX has been shown to reduce exercise-induced hyperthermia in individuals with spinal cord

injury (Hagobian et al., 2004) and with multiple sclerosis (Grahn et al., 2008) and to improve aerobic exercise endurance in a hot environment (Grahn et al., 2005; Hsu et al., 2005). Anecdotally, the RTX has been reported to enhance an athlete's work capacity during strength training, especially when the athlete is working at near maximum performance levels. However, there are no published findings to support these individual observations.

This investigation was undertaken to determine if there are significant differences in muscle fatigue and neuromotor measurements, as well as subjective perceptions of fatigue when trained people perform sets of high intensity isotonic exercise (bench press) with cooling applied to the hands during rest intervals between sets. We hypothesized that total work volume during multiple sets of high intensity bench press exercise will be increased by cooling applied to the palms during the rest period between sets compared to local heating or thermoneutral conditions. We also measured esophageal temperature (T_{es}) in a subgroup (only 6 subjects tolerated the esophageal thermocouple probe placement) to determine whether centrally-induced changes in temperature are produced when using the RTX.

A second purpose of this study was to determine whether altering the temperature of the hands during resistance exercise alters the surface EMG response. Surface EMG has been shown to be an acceptable method for quantifying muscle recruitment and muscle fatigue noninvasively (Edwards, 1981). We hypothesized that cooling the hands between sets would increase the Root Mean Square (RMS) (an index of muscle recruitment) and decrease or maintain Mean Frequency (MF) (an index of muscle fatigue) and the Median Frequency (MD) (another index of muscle fatigue) of the EMG.

Warming the hands should have no effect on RMS, MF or MD. Finally, we hypothesized that heart rate and the subjective perception of fatigue would be reduced during cooling compared to the thermoneutral and heating conditions.

METHODS

Subjects. Sixteen healthy male subjects volunteered for this study. Subjects participated in regular, intense weight training for a minimum of 2 years, and their ratio of weight pressed to body weight during bench press was more than 80% of age-based upper body strength (ACSM guidelines, 2010). The characteristics of the participants are summarized in Table 1. The protocol for this study was approved by the University of New Mexico Human Research Review Committee and all subjects provided informed, written consent prior to participation.

TABLE 1. Characteristics of the participants (n=16)

Characteristic	Mean \pm SD
Age (yr)	26 \pm 6
Height (cm)	178 \pm 7
Body mass (kg)	81.5 \pm 11.3
Body fat (%)	10.3 \pm 5.4
1RM (kg)	123.5 \pm 12.6
Seated Systolic/Diastolic Blood pressure (mmHg)	118 \pm 7 / 73 \pm 5
The ratio of weight pressed to body weight	1.5 \pm 0.2
Training experience (yr)	10 \pm 6

Subjects were screened for cardiovascular or musculoskeletal disease using a medical history questionnaire, an activity questionnaire, and the Physical Activity Readiness Questionnaire (PAR-Q) (Heyward, 2002). All subjects had less than two positive cardiovascular risk factors as outlined by the American College of Sports

Medicine (ACSM guidelines, 2010). Subjects were excluded from the study if they had high blood pressure or they were taking ergogenic supplements that could affect exercise performance. After the initial screening, body density was determined using the sum of three skin fold sites and the Jackson & Pollock equations; ethnic and gender specific equations were used to calculate percentage of body fat from body density (Jackson & Pollock, 1978).

Overall protocol

There were a total of four experimental days. During the first testing day, subjects were familiarized with the testing protocol, they performed a 1RM supine bench press test and after 5 min of rest they completed one endurance set to fatigue at 85% of 1RM. Before the first 1RM test, each subject gained familiarity with the barbell bench press exercise by performing it under the guidance of the primary investigator. Subjects were trained to perform each concentric and eccentric phase of the bench press through a fixed range of motion and at a rate of 2 sec up and 2 sec down in time. During the other three days, they performed the same 1RM and one set of 85% 1RM performed during the first day, but they then also performed three additional endurance sets at 85% of 1RM. During the rest periods between sets 2-4, the hand was exposed to either: thermoneutral (TN) with negative pressure, local palm cooling (PC) with negative pressure, or local palm heating (PH) with negative pressure (Figure 1). A counterbalanced design was used to minimize any learning or order effects. All tests were done at the same time of day for each subject. Subjects were instructed to eat a light meal two hours before coming to the

laboratory. All testing took place at an altitude of 1572 m (PB=635mmHg) in the months of April through May.

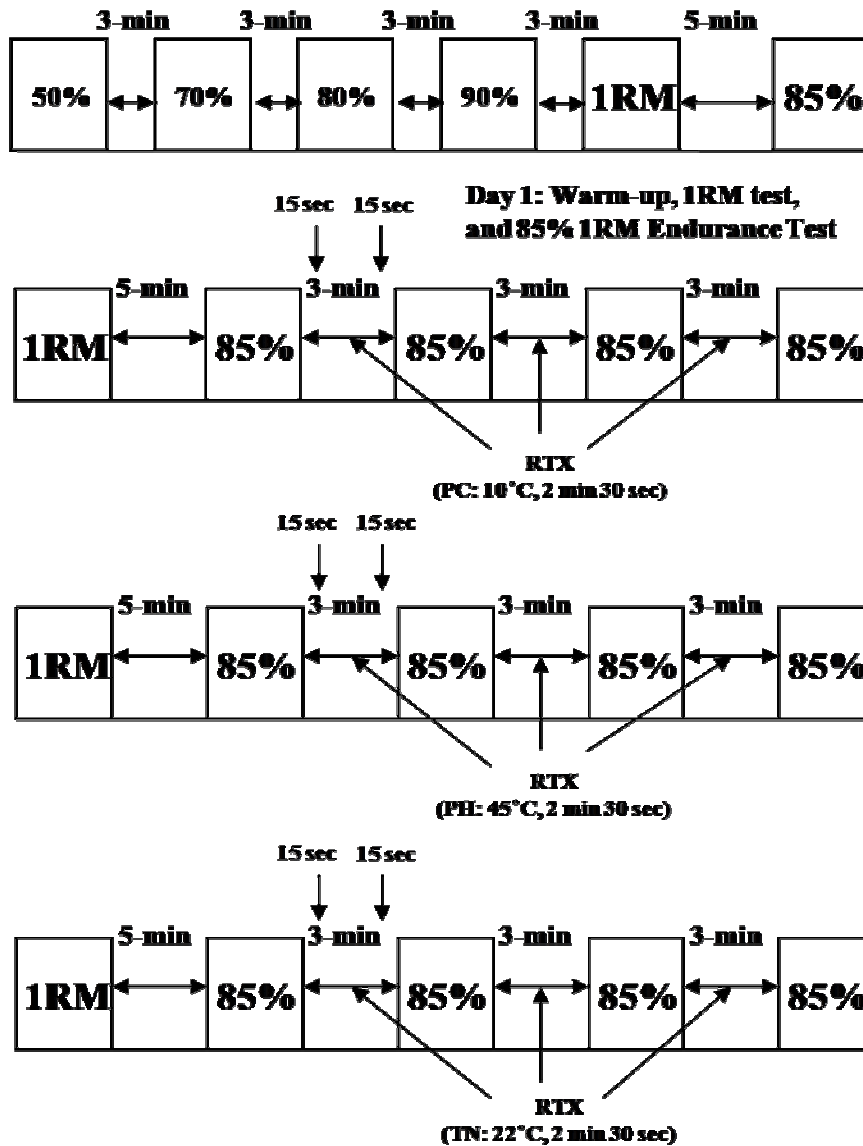

FIGURE 1-Protocols for Warm-up, 1RM test, and 85% of 1RM 4 sets of bench press test thermoneutral (TN), palm cooling (PC), and palm heating (PH) conditions. Exercise intensity (% of 1RM) is denoted in each column representing each set. After 1RM and the 1st set, the exercise in three sets of every protocol continued until the subjects failed to complete a lift.

Procedures during each Testing Day

Treatment conditions

Hand cooling and heating with negative pressure were induced by using two Rapid Thermal Exchanger (RTX) hand cooling devices, one on each hand (RTX Heating/Cooling Model # 200962-006B, AVAcore Inc., Palo Alto, CA). The RTX consists of a metallic cone heat-exchanger surface on which the palm of the hand is placed and a plastic chamber that encloses the hand. A seal above the wrist allows an air-tight seal around the wrist to maintain a vacuum around the hand. Air is pumped from the device and negative pressure can be controlled and maintained. The wrist seal was tightened just to the point where a vacuum could be maintained. The circulating water temperature was maintained at 10°C during the cooling trials and 45°C during the heating trials, and negative pressure was maintained at 45mmHg. For cooling and heating trials, the hand was cooled or heated for 2 min and 30 seconds during each rest period after the 1st 85% of 1RM set. The control trials consisted of placing the hand in the RTX with negative pressure but without application of cold or hot water.

Exercise Procedures

Day 1: 1RM and 1 85% of 1RM endurance test

On a testing day, participants were asked if they had any soreness or injury to their shoulders, triceps, and chest and if they had refrained from caffeine and vigorous exercise in the previous 24 hours. Each subject did their usual warm-up and they positioned themselves under the bar with their usual grip. The positions of the minimus fingers of each hand were marked on the bar to insure the same grip distance on the bar during all tests. The type of grip used (closed or open) was self-chosen. Supine bench press strength was assessed by measuring the 1 repetition max (1RM), and after 5

minutes an 85% of 1RM endurance test was performed. The 1RM bench press was determined according to the methods described by Kraemer et al. (1991). Subjects were required to perform a warm-up of 10 repetitions at 50% of (predicted) 1RM, 5 repetitions at 70% of 1RM, 3 repetitions at 80% of 1RM, and 1 repetition at 90% of 1RM, followed by 3 attempts to determine the subject's actual 1RM. All subjects were given 3 minutes of rest between sets. After the 1RM test, subjects had a 5-minute rest period and then tried to lift as many repetitions possible using 85% of 1RM. A 1RM test was performed before each fatigue test because the EMG signal from the muscle surface varies from one location to another, and thus the absolute EMG signal cannot be compared between separate days. The EMG during the 1RM test was used to normalize the submaximal EMG data.

Days 2, 3, and 4: 1 RM and four 85 % 1RM endurance tests

The participants were required to perform a warm-up of 10 repetitions at 50% of 1RM, 5 repetitions at 70% of 1RM, 3 repetitions at 80%, and 1 repetition at 90% of 1RM, stretching chest, shoulder and triceps between sets. After 5 minutes they lifted their 1RM. After another five min of rest, four sets with weights of 85% of 1RM were performed until fatigue. Between each set they rested for three minutes. The 3-min rest periods between sets 2, 3, and 4 consisted of a 15 second transition from the exercise to the treatments, 2 minutes 30 seconds of PC (10°C), PH (45°C), or a TN trial with negative pressure, and another 15 second transition from the rest period to the next set. EMG measurements were obtained throughout the 1 RM and four endurance tests. (Figure 1)

Specific Measurements

Rating of Perceived Exertion (RPE)

Immediately after each endurance test, participants were asked to answer the question “How was your workout?” to find their perceived exertion following the completion of each set based on a modified 10-point RPE scale (0: Rest and 10: Maximal) (Day et al., 2004).

Esophageal and Palm Temperatures

Uncovered skin thermistors (Grant Instruments Ltd, Cambridge, UK) were attached to the right palm with elastic straps during the TN condition. During PC and PH conditions, palm temperature was measured by the RTX (by thermocouples embedded in the hand cone). In each condition, palm temperatures (T_{pa}) were recorded during 2 min and 30 sec of the rest periods. A subgroup of subjects ($n=6$) inserted a calibrated esophageal thermistor (YSI Precision 4400 Series, Yellow Springs Inc., Yellow Springs, OH) through their nose and into the esophagus. The thermistor was inserted to $\frac{1}{4}$ of the subject's height and the depth was adjusted ± 1 inch to obtain the highest reading. All thermistors were connected to a Squirrel data logger (Grant Instruments Ltd, Cambridge, UK), which recorded esophageal temperature (T_{es}) and palm temperature during the TN condition every five seconds. Palm temperature during PC and PH conditions were recorded manually every 15 sec.

EMG

Gel electrodes were placed on the belly of the following muscles on the left side of the body aligned parallel to the muscle fibers; the sternal head of the pectoralis major (PM), the anterior deltoid (AD), the long head of the triceps brachii (LT), the lateral head of the triceps (LTT) brachii, and on the styloid process of ulna as a ground. In all cases the line between two electrodes was parallel to the muscle's line of pull. The electrode sites were prepared by shaving, abrasion with sandpaper, and swabbing with an alcohol prep to lower skin resistance. Each electrode was secured by adhesive tape. The electrode sites were marked using an anatomical pen on the skin to insure the same site was used on different days. Muscle EMG voltage signals were acquired at a rate of 1500 Hz from a MyoSystem 1200 (Noraxon Inc., Scottsdale, Arizona), diverted to an analog signal acquisition system through a 68 pin junction box (CA1000 unit, National Instruments, Austin, TX), connected in series to a data acquisition card (National Instruments, Austin, TX) and collected using custom written software (LabVIEW, National Instruments, Austin, TX). To aid in post-collection signal processing, an electronic goniometer (Biopac Systems, Santa Barbara, CA) was attached to the elbow to provide a signal at 1500 Hz to monitor changes in elbow flexion and extension. No filters were applied to raw EMG data. Raw EMG signal processing was completed post collection using custom written software (LabVIEW, National Instruments, Austin, TX). This involved isolation of EMG signals from the PM, the AD, the LT and the LTT during every muscle contraction based on the goniometer signal. The concentric and eccentric movement from each contraction was also differentiated based on the goniometric signal. The root mean square (RMS) and spectrum analysis for frequency domain, mean frequency (MF) and median frequency (MDF) for each contraction were then calculated with fast Fourier

transformation analysis. The electrical manifestations of muscle activity and muscle fatigue were investigated by tracking the variation of the instantaneous RMS and MF and MDF of the surface myoelectric signals during the 1 RM and the first contraction of the 1st set of 85% 1RM and the last contraction of the 4th set of 85% of 1RM. One subjects was excluded because he was not able to lift more than one repetition after 1st set.

Power Analysis. The number of subjects was based on a power analysis using data from Verducci (2000). Without cryotherapy, the average total work was 52795 ± 7424 joules (average \pm SD) while with cryotherapy the average total work was 60233 ± 8223 joules. Using the standard deviations from Verducci's data, approximately 16 subjects would be sufficient to detect a significant difference in average total work between hand cooling and no cooling ($\alpha=0.05$ and a power of 0.8). Therefore, we recruited sixteen healthy, resistance-trained male subjects for this study.

Statistical analyses. All statistical computations were performed using STATISTICA version 7.1 software (StatSoft, Inc., Tulsa, OK). A two-way, repeated-measures ANOVA test was used to quantify the differences in heart rate, Tes, Tpa and RPE between conditions (TN, PC, PH) and the 4 sets. Exercise volumes (Kg, Sets \times Repetitions \times Weight) among conditions were compared using a one-way repeated-measures ANOVA. When a significant F-ratio was obtained, a Tukey's Honestly Significant Differences test was performed. Statistical significance was accepted at $p < 0.05$. All data are presented as the mean \pm SD.

RESULTS

Environmental Variables.

There were no differences in ambient temperature (TN, $23.6 \pm 1.2^{\circ}\text{C}$, PH, $23.5 \pm 0.8^{\circ}\text{C}$, PC, $23.5 \pm .9^{\circ}\text{C}$, $p=0.99$), relative humidity (TN, $18 \pm 9\%$, PH, $18 \pm 9\%$, PC, $18 \pm 9\%$, $p=0.98$) or barometric pressure (TN, $631 \pm 3\text{mmHg}$, PH, $632 \pm 3\text{mmHg}$, PC, $631 \pm 3\text{mmHg}$, $p=0.55$) during the three conditions.

Mean palm skin temperature during rest periods among the three conditions.

There were significant differences in palm skin temperature during rest periods between conditions ($p<0.01$), Figure 2. There were no significant differences within a condition between the three rest periods.

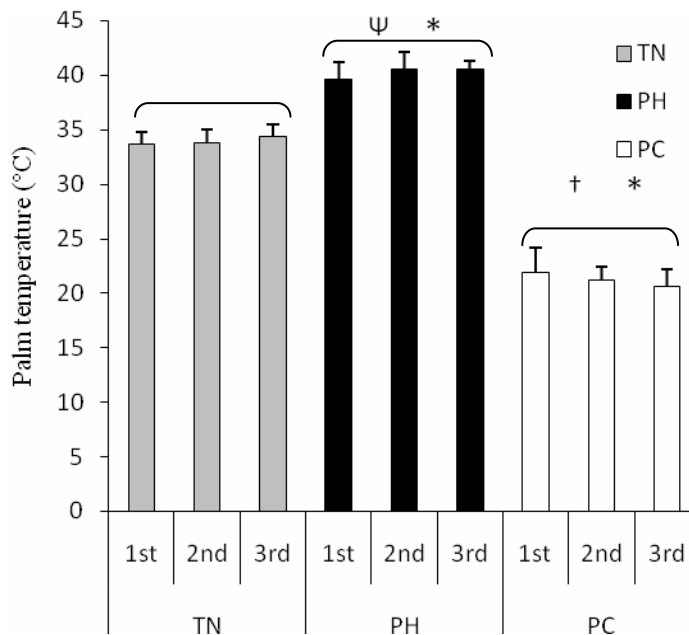

FIGURE 2-Mean palm skin temperature response during the four 85% of 1RM sets of bench press test during rest periods during thermoneutral (TN), palm cooling (PC), and palm heating (PH) conditions. Each value represents the mean palm skin temperature ($n=16$). Error bars indicate SD.

Asterisk (*) indicates PC vs. PH conditions ($p < 0.01$). Symbol (†) indicates PC vs. TN conditions ($p < 0.01$). Symbol (ψ) indicates PH vs. TN conditions ($p < 0.01$).

Repetitions

The number of repetitions to exhaustion per set were different ($p < 0.01$), Figure 3. The PC (5.9 ± 2.1) condition had significantly higher mean repetitions than TN (4.7 ± 2.2) and PH (5.1 ± 1.1) conditions. There was no significant difference in mean repetitions ($p = 0.06$) between TN and PH conditions. The condition \times set interaction effect was significant ($p < 0.01$). In the PC condition, the 2nd set had significantly higher ($p < 0.01$) repetitions (7.5 ± 2.1) than both the TN (5.1 ± 1.7) and the PH (6.0 ± 2.0). The 3rd set of the PC condition had significantly higher repetitions (5.1 ± 1.3) than the 3rd set during TN (3.6 ± 1.8) ($p < 0.01$) and PH (4.2 ± 1.7) ($p < 0.01$), and the 4th set of the PC condition had higher repetitions (4.4 ± 1.3) than TN (3.4 ± 1.4) ($p < 0.01$) and PH (3.7 ± 1.3) ($p < 0.05$). In the PH condition the 2nd set had higher repetitions (6.0 ± 2.0) than the 2nd set in TN (5.1 ± 1.7) ($p < 0.05$).

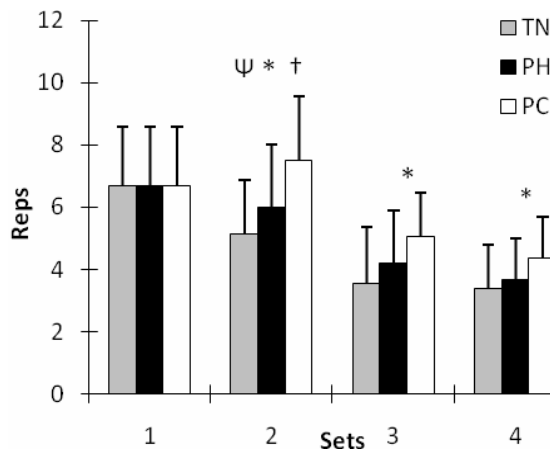

FIGURE 3-Repetitions during the four 85% of 1RM sets of bench press test during thermoneutral (TN), palm cooling (PC), and palm heating (PH) conditions. Each value represents the mean repetitions (n=16). Error bars indicate SD. Asterisk (*) indicates PC

vs. PH conditions ($p < 0.05$). Symbol (\dagger) indicates PC vs. TN conditions ($p < 0.05$). Symbol (ψ) indicates PH vs. TN conditions ($p < 0.05$).

Exercise volume

There were significant differences in exercise volume between the TN, PH, and PC conditions. Mean exercise volume (kg) of PC (2479 ± 636) was significantly higher than both PH (2156 ± 668), $p < 0.01$ and TN (1972 ± 632), $p < 0.01$; There was no significant difference between TN and PH in exercise volume ($p = 0.08$), Figure 4.

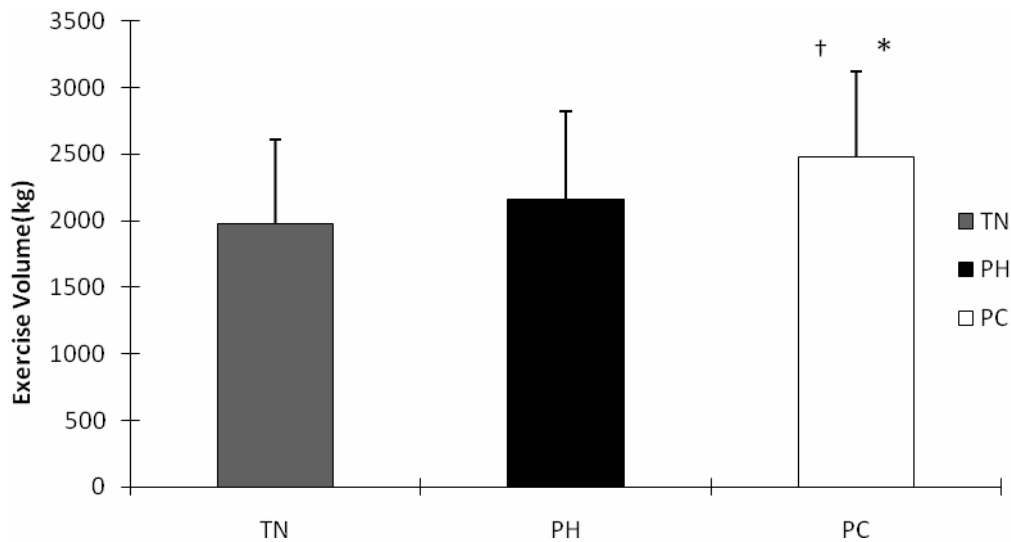

FIGURE 4-Total exercise volume of the four 85% of 1RM sets of bench press test during room temperature (TN), palm cooling (PC), and palm heating (PH) conditions. Each value represents the mean volume ($n=16$). Error bars indicate SD. Asterisk (*) indicates PC vs. PH conditions ($p < 0.05$). Symbol (\dagger) indicates PC vs. TN conditions ($p < 0.05$).

Core temperature in 6 subjects

Tes was significantly different among conditions, $p < 0.01$. PC condition (36.97 ± 0.08) had significantly lower mean Tes than both PH (37.02 ± 0.10) $p < 0.01$ and TN (36.99 ± 0.08), $p < 0.05$ conditions. There also was a significant time effect between

baseline, rest periods, and 1min post-exercise after the 4th set, $p < 0.01$. The condition \times set interaction effect was significant ($p < 0.01$), Figure 5.

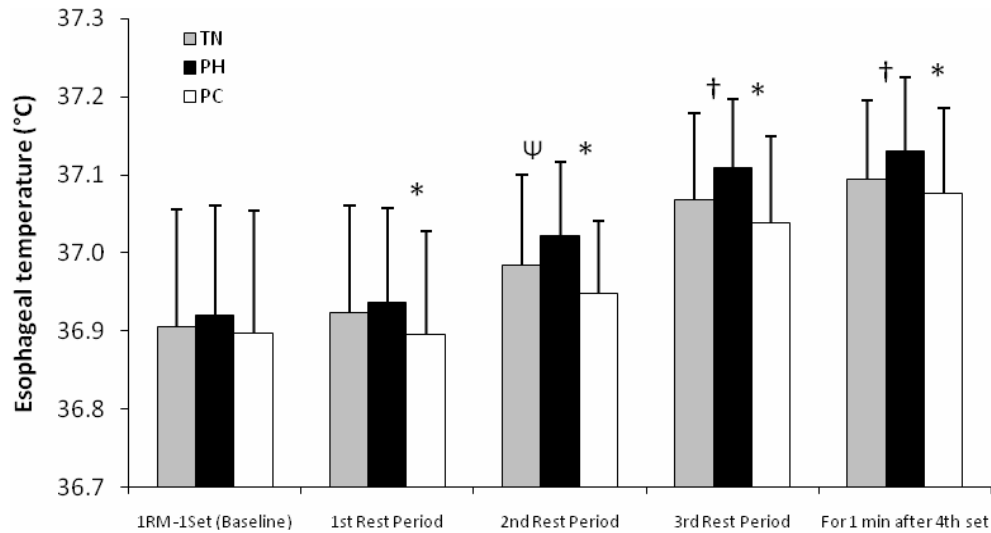

FIGURE 5-Esophageal temperature (Tes) during baseline, rest periods, and 1 min after the 4th set during the four 85% of 1RM sets of bench press test during thermoneutral (TN), palm cooling (PC), and palm heating (PH) conditions. Each value represents the mean Tes (n=6). Error bars indicate SD. Asterisk (*) indicates PC vs. PH conditions ($p < 0.01$). Symbol (†) indicates PC vs. TN conditions ($p < 0.01$). Symbol (ψ) indicates PH vs. TN conditions ($p < 0.01$).

Rating of perceived exertion (RPE)

RPE was significantly different among conditions, $p < 0.05$. RPE during PC (6.7 ± 0.8) was significantly lower than during PH (7.0 ± 1.1), ($p < 0.05$). There were no differences between PC and TN (7.0 ± 1.2), ($p = 0.08$) or between TN and PH conditions ($p = 0.87$).

RPE was significantly different between sets, $p < .001$, Figure 6. The condition \times set interaction effect also was significant, $p < .05$. In PC trials, the 2nd set (6.2 ± 0.9) had significantly lower RPE than TN (6.6 ± 2.5) and PH (6.7 ± 1.0), ($p < 0.05$). In PC trials, the 4th set (7.6 ± 1.1) had significantly lower RPE than PH (8.2 ± 1.1), ($p < 0.05$).

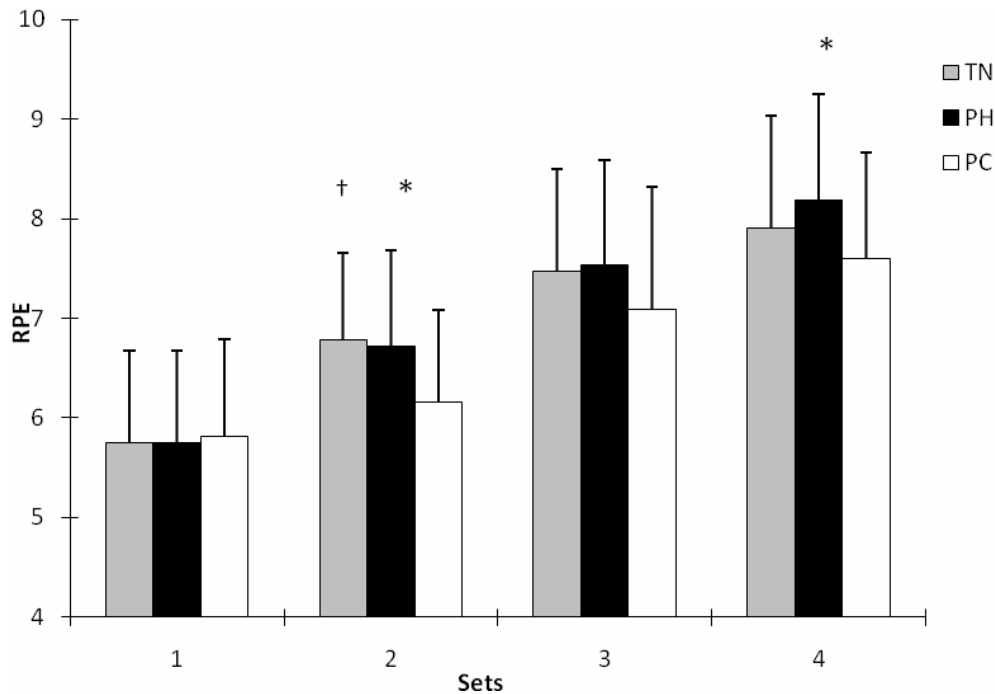

FIGURE 6-RPE response during the four 85% of 1RM sets of bench press test during thermoneutral (TN), palm cooling (PC), and palm heating (PH) conditions. Each value represents the mean repetitions (n=16). Error bars indicate SD. Asterisk (*) indicates PC vs. PH condition ($p < 0.05$). Symbol (†) indicates significant difference between PC and TN ($p < 0.05$).

Heart rate

HR was significantly different among the conditions, $p < 0.05$. Heart rate (bpm) during TN trials (108 ± 26) was lower than during PH trials PH (112 ± 26), $p < 0.05$. There were no differences between TN and PC (108 ± 28) and between PH and PC trials, $p = 0.07$. HR was different from baseline during exercise and rest periods, $p < 0.01$, figure 8. The interaction effect also was significant, $p < 0.01$. During the 2nd set HR during PC (141 ± 19) was significantly higher than during TN (135 ± 18), $p < 0.05$. During the rest period between the 2nd and 3rd sets, HR during PH (88 ± 21) was significantly higher than during TN (86 ± 21), $p < 0.01$, and PC (83 ± 20), $p < 0.01$. During the rest period between the 3rd and

4th sets, HR during PH (91±21) was significantly higher than PC (86±21), $p < 0.01$.

During 1 min post-exercise, HR during PH (100±20) was significantly higher than PC (94±21), $p < 0.01$, and TN (95±21), $p < 0.05$, Figure 7.

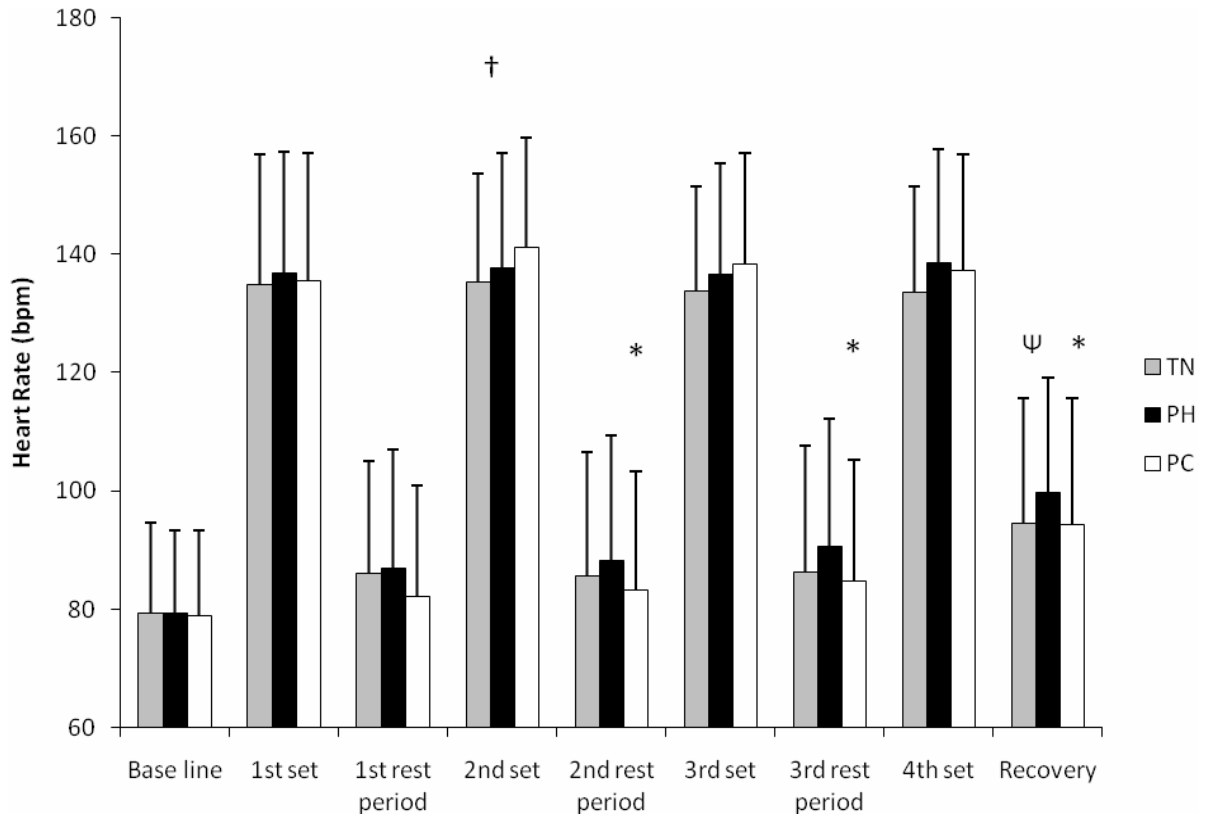

FIGURE 7-Heart rate response during the four 85% of 1RM sets of bench press test during thermoneutral (TN), palm cooling (PC), and palm heating (PH) conditions. Each value represents the mean repetitions (n=16). Error bars indicate SD. Asterisk (*) indicates PC vs. PH trials ($p < .01$). Symbol (†) indicates significant difference between PC and TN ($p < .01$). Symbol (ψ) indicates significant difference between PH and NC ($p < .05$).

EMG

There were significant differences in EMG values during both eccentric and concentric movements only in the lateral head of the triceps (Table 3). The RMS % difference

between the first rep of the 1st set and the last rep of the 4th set were significantly different among the TN, PH, and PC conditions. During eccentric movements, the RMS difference (%) during PC (40 ± 18) was significantly higher than both PH (19 ± 14), $p < 0.01$ and TN (13 ± 20) $p < 0.01$ conditions; There was no significant difference between TN and PH in mean RMS difference ($p = 0.06$). For concentric movements, there also were significant differences in EMG RMS difference (%) from the first rep of 1st set to last rep of the 4th set between the TN, PH, and PC, $p < .001$. The mean difference (%) of PC (53 ± 30) was significantly higher than both PH (19 ± 19), $p < .001$ and TN (14 ± 12), $p < .001$. as shown in Figure 8. There was no significant difference between TN and PH in mean difference (%). There were no significant differences in MF or MDF in any of the muscles during eccentric or concentric contractions.

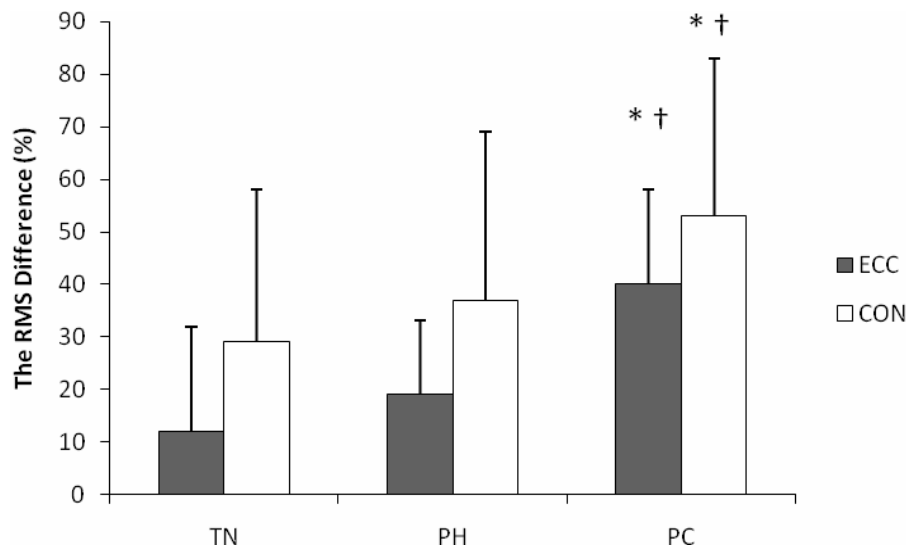

FIGURE 8-The mean difference (%) in RMS during eccentric and concentric contraction in the lateral head of triceps during the four 85% of 1RM sets of bench press testing during room temperature (TN), palm cooling (PC), and palm heating (PH) conditions. Each value represents the mean volume (n=16). Error bars indicate SD. Asterisk (*) indicates PC vs. PH conditions ($p < 0.05$). Symbol (†) indicates PC vs. TN conditions ($p < 0.05$). RMS, root mean square; ECC, Eccentric; CON, concentric

TABLE 2. The mean difference (%) in RMS, MF, and MDF during eccentric and concentric contractions during the four 85% of 1RM sets of bench press test during thermoneutral (TN), palm cooling (PC), and palm heating (PH) conditions, (n=15).

Muscle	EMG Variable (%)	Contraction	Change (%)			P Value
			TN	PH	PC	
The Pectoralis Major	RMS	ECC	47±21	40±20	42±19	.58
		CON	45±17	38±18	44±19	.49
	MF	ECC	23±15	21±17	18±19	.55
		CON	28±13	23±15	26±13	.43
	MDF	ECC	25±11	20±10	27±12	.12
		CON	23±9	20±22	26±13	.58
The Lateral Head of Triceps	RMS	ECC	12±20	19±14	40±18*†	0.01
		CON	29±29	37±32	53±30*†	0.01
	MF	ECC	10±11	19±19	18±10	.20
		CON	18±10	17±12	22±10	.25
	MDF	ECC	14±11	21±15	20±10	.31
		CON	22±14	19±12	26±13	.21
The Anterior Deltoid	RMS	ECC	23±17	19±16	32±15	8.65
		CON	28±24	17±18	38±44	0.20
	MF	ECC	10±12	12±13	13±13	0.74
		CON	16±9	14±10	21±10	0.06
	MDF	ECC	8±14	10±18	15±16	0.41
		CON	18±12	17±12	24±9	0.10
The Long Head of Triceps	RMS	ECC	31±26	31±19	36±25	0.65
		CON	24±23	29±26	20±14	0.45
	MF	ECC	14±10	13±8	15±7	0.86
		CON	8±21	12±13	13±9	0.69
	MDF	ECC	16±7	18±8	19±9	0.64
		CON	15±19	18±16	16±12	0.84

Data are presented as mean±SD.

RMS, root mean square; MF, Mean Frequency; MDF, Median Frequency; ECC, Eccentric; CON, concentric; TN, thermoneutral; PH, palm heating; PC, palm cooling

Asterisk (*) indicates PC vs. PH conditions ($p < 0.01$).

Symbol (†) indicates PC and TN conditions ($p < 0.01$).

DISCUSSION

This is the first study to our knowledge, to assess the impact of palm cooling and heating on fatigue during high intensity, multi-set bench press exercise. Our results confirm that palm cooling during rest periods between sets increases dynamic muscle

endurance and exercise volume. We speculate that palm cooling exerts an ergogenic effect in trained subjects during short duration high intensity resistance exercise through either a delayed central fatigue mechanism or through a peripheral counter-irritation effect.

Our finding that palm cooling increases weight lifted during resistance exercise replicates previous finding using cryotherapy between weight-pulling sets (Verducci 2000). Certainly, there were differences in the cooling surface area, method of cooling, and cooling duration during rest periods between the present study and that of Verducci (2000). Verducci suggested that his protocol, which involved 22 repetitions at a high velocity and at 75% of 1RM with 8 min of rest between sets, may not be transferable to strength training at higher intensity. Our study which used 85% of 1RM intensity, 4 sets, and 3 minutes between set intervals represents a more traditional exercise protocol for improving strength (Baechle and Earle, 2000).

Unlike most previous studies using cryotherapy, we conducted cooling between exercise sets, rather than before or after the exercise. Pre-cooling may cause adverse muscular performance if one performs short duration, high intensity exercise immediately after cooling the active muscles. Previous investigators reported no effect (Davis & Young, 1983; Howard et al., 1994; Evans et al., 1995; Cross et al., 1996) or decreased endurance, or strength (Mattacolar and Perrin, 1993; Ruiz et al, 1993, Cornwall, 1994; Howard et al., 1994; Hatzel and Kaminski, 2000; Douris et al., 2003) after pre-cooling the muscles. In addition, most cooling studies except Verducci (2000; 2001), included 10-45 minutes of cooling, because they intended to lower the muscle temperature to study effects of temperature on muscle function. In comparison, we used a short cooling

duration, a limited cooling surface area and applied cooling during rest periods between sets to improve muscle function. These differences in cooling approach may explain why our results do not agree with these previous studies.

Our findings that palm cooling with negative pressure during rest periods between sets lowered esophageal temperature during exercise is similar to the findings of Grahn et al. (2005), where heat extraction from the palm improves aerobic endurance. Certainly, there are differences in exercise mode between the present study and that of Grahn et al. (2005). These researchers reported improved aerobic exercise endurance while applying cooling and subatmospheric pressure to one hand during exercise. They attributed the increase in endurance time to cardiovascular effects caused by the lower core temperature. The rationale why they cooled the palms of the hands is that this area of the body has circulatory adaptations that enhance heat dissipation despite the small surface area for cooling. Like the dog's tongue, rabbit's ear, and penguin's feet, these areas contain arterial venous anastomoses (AVAs) that can shunt blood directly from arterioles to venous plexuses, which act as radiators (Grahn et al, 1998). Previous studies showed cooling these areas was an effective method of heat removal (Livingstone et al., 1989; 1995; Hagobian et al., 2003; Grahn et al., 2005; Hsu et al., 2005; Giesbrecht et al., 2007; Grahn et al., 2008; Khomenok et al., 2008). The rationale why they applied subatmospheric pressure to this area during cooling is that it may enhance heat transfer by opposing a reflex vasoconstriction response which would reduce perfusion of the AVAs during cooling.

Interestingly, we found that the repetitions in the second set were increased not only after PC but also in the PH condition, compared to the TN condition. It is possible

this explained by a placebo effect or the Hawthorne effect (Jones, 1992). Subjects might have believed they were receiving special attention when heating or cooling was applied. To reduce this effect, the RTX also was used in TN condition; however, a psychological effect still may have influenced the results. If there are real differences among conditions, they may be explained as follows. Verducci (2000; 2001) and Burket et al. (2000) discussed the beneficial effects of cryotherapy on pain reduction as the cause of their positive results. According to the Gate Control Theory described by Melzack and Wall in 1965, physical pain is not a direct result of activation of pain receptor neurons, but rather the perception of pain which is modulated by interaction between different sets of neurons. This theory provides the rationale for interventions to “close the gate” to pain transmission. Several peripheral stimuli, such as cooling, heating, vibration, and rubbing can close the gate to pain and thus increase pain threshold. For example, electrical impulses from transcutaneous electrical nerve stimulation application can be used to preferentially block pain impulse transmission. Input from thermal modalities such as heat or cold can also be used to decrease pain. “Counter-irritation” (relieving pain in one place by irritating another site) is another term often used to describe the Gate Control Theory (Gammon & Starr, 1941; Ikai & Steinhaus, 1961; Knight, 1995). Gammon and Starr (1941) studied the effectiveness of applying hot-water bottles and ice packs over the skin as counterirritants, and they concluded that these counterirritants provided only temporary relief of pain. They therefore suggested that intermittent application of an irritant was more effective than continuous application. When thermal impulses are transmitted, the sensory output moves through fast nerve fibers and can “block” pain transmission which moves through slower nerve fibers to the substantia gelatinosa, the

region in the spinal cord which integrates all peripheral signals that are then transmitted to the brain. If the brain is receiving pain signals during high intensity resistance training, it is possible that stimulation of these thermal receptors might alter the input to the CNS motor center, reduce central fatigue, and result in more repetitions during a set of resistance exercise. Our results suggest that acute heat produce a smaller reduction in repetitions in the 2nd set compared to TN. However during PC, the repetitions in the 2nd set were even more than the reps in the 1st set. Cold receptors are more numerous (up to 10 times) than warm receptors in hand skin layers (Jones & Lederman, 2006). Cold receptors discharge most vigorously at skin temperatures of 25°C (Guyton, 1996; Jones & Lederman, 2006) whereas, warm receptors discharge with increasing skin temperature and reaching a maximum at 45-50°C (Pierau & Wurster, 1981). Our subjects' hand temperature during PC and PH were around 22°C and 40°C, respectively. The greater improvement in both total volume and 2nd set repetitions during PC than PH may have resulted from a greater number of cold receptors stimulated as well as a stronger stimulus more; the hand temperature during cooling was colder than the temperature that producing a maximal response. This ergogenic effect can also be seen in our study by the reduced HR and RPE ratings during sets 2-4 in the PC condition. These physiological data also support that the endurance data were not caused by a Hawthorne effect.

The EMG response. Fatigue in a muscle is reflected by specific changes in the EMG recording in the time (RMS) or frequency (MF and MDF) domains (Edwards 1981). An increase in RMS might reflect greater total muscle fiber recruitment for a fixed submaximal external force (Edwards, 1981; Newham et al., 1983). A shift of frequency domain towards lower frequencies would reflect fatigue state (Bigland-Ritchie et al.,

1981). In our study the RMS was either the same in most muscle graphs, despite a greater number of reps, or increased in the lateral head of the triceps. We also found a shift of MF and MDF towards lower frequencies. Thus EMG signal suggested that cooling resulted in at least the same degree of muscle fatigue, despite a greater volume of work performance.

Some studies have been conducted to better understand the demands and effects of a bench press on the EMG activity of specific muscles. Legally et al. (2004) and Lehman (2005) observed that the most activated muscle was the triceps brachii, whereas Welsch et al. (2005) found similar levels of activation for both the anterior deltoid and the pectoralis major. In the present study we found the most activated muscle was the pectoralis major and the 2nd most activated muscle was the lateral head of triceps. We measured each head of the triceps brachii separately, that is we measured EMG from both the lateral and long head of triceps. If we combined the recordings from these two heads our findings are similar to those of Legally et al. (2004) and Lehman (2005).

We also found that the RMS of the lateral head of triceps brachii was different during eccentric and concentric movements and also were different among conditions. Absolute eccentric RMS was lower than concentric RMS in every muscle and every condition. Both eccentric and concentric RMS increased as subjects lifted weight. An eccentric movement during training is critically important to increase bench press strength (Doan et al., 2002). If cooling the hands increases muscle recruitment during the eccentric phase, it might also cause more recruitment during the concentric phase. Our results during eccentric movements showed that the RMS during PC was higher than both PH and TN in the lateral head of the triceps. This might be affected by not only

cooling the hands itself, but also by additional eccentric muscle fiber recruitment. The effect of an increased recruitment with PC from the first repetition of 1st set to the last repetition of 4th set may be to increase endurance through the whole sets rather than to increase absolute strength. If palm cooling during bench press exercise can delay fatigue, it may allow a greater training volume and thus a more efficient training response. (Baechle & Earle, 2000)

Conclusions

Palm cooling using the RTX between sets of high intensity bench press exercise resulted in increased repetitions to exhaustion and a greater exercise volume as well as lower heart rates and RPE during exercise. This improvement in training volume was associated with a greater recruitment of muscle fibers from the lateral head of triceps, and may have involved a delayed central fatigue or a peripheral counter-irritation effect caused by output from hand thermal receptors. These results suggest that palm cooling may provide an ergogenic effect to enhance the training response of progressive resistive exercise.

REFERENCES

1. ACSM. *ACSM's Guidelines for Exercise Testing and Prescription*, 8th ed. Philadelphia (PA): Lippincott, Williams & Wilkins; 2010. p. 92.
2. Asmussen E, Boje O. Body temperature and capacity for work. *Acta Physio Scand*. 1945;10:1-22.
3. Baechle TR, Earle R. *Essentials of strength training and conditioning*. 2nd ed. Champaign, IL: Human Kinetics; 2000. p.291-316.
4. Bigland-Ritchie B, Donovan EF, Roussos CS. Conduction velocity and EMG power spectrum changes in fatigue of sustained maximal efforts. *J Appl Physiol*. 1981;51(5):1300-5.

5. Burke DG, MacNeil SA, Holt LE, MacKinnon NC, Rasmussen RL. The effect of hot or cold water immersion on isometric strength training. *J Strength Cond Res.* 2000;14(1):21-25.
6. Clarke RSI, Hellon RF, Lind AR. The duration of sustained contractions of the human forearm at different muscle temperatures. *J Physiol (London).* 1958;143(3):454-73.
7. Cornwall MW. Effect of temperature on muscle force and rate of muscle force production in men and women. *J Orthop Sports Phys Ther.* 1994;20(2):74-80.
8. Davies CTM, Young K. Effects of temperature on the contractile properties and muscle power of triceps surae in humans. *J Appl Physiol.* 1983;55(1):191-195.
9. Day ML, McGuigan MR, Brice G, Foster C. Monitoring exercise intensities during resistance training using a session RPE scale. *J Strength Cond Res.* 2004;18(2):353-358.
10. Deluca CJ. Myoelectrical manifestations of localized muscle fatigue in humans. *Crit Rev Biomed Eng.* 1984;11(4):251-279.
11. Doan BK, Newton RU, Marsit JL, et al. Effects of increased eccentric loading on bench press 1RM. *J Strength Cond Res.* 2002;16(1):9-13.
12. Douris P, McKenna R, Madigan K, Cesarski B, Costiera R, Lu M. Recovery of maximal isometric grip strength following cold immersion. *J Strength Cond Res.* 2003;17(3):509-513.
13. Edwards RH. Human muscle function and fatigue. Human muscle fatigue: physiological mechanisms. In: *Ciba Foundation symposium 82*; 1992: London: Pitman Medical; 1981. p.1-18.
14. Evans TA, Ingersoll C, Knight KL. Agility following the application of cold therapy. *J Athl Train.* 1995;30(3):231-234.
15. Gammon GD, Starr I. Studies on the relief of pain by counterirritation. *J Clin Invest.* 1941;20(1):13-20.
16. Giesbrecht GG, Jamieson C, Cahill F. Cooling hyperthermic firefighters by immersing forearms and hands in 10 degrees C and 20 degrees C water. *Aviat Space Environ Med.* 2007;78(6):561-7.
17. Grahn DA, Cao VH, Heller HC. Heat extraction through the palm of one hand improves aerobic exercise endurance in a hot environment. *J Appl Physiol.* 2005; 99(3):972-8, 2005.

18. Grahn DA, Murray JV, Heller HC. Cooling via one hand improves physical performance in heat-sensitive individuals with multiple sclerosis: a preliminary study. *BMC Neurology*. 2008;12:8-14.
19. Glass S, Armstrong T. Electromyographical activity of the pectoralis muscle during incline and decline bench press. *J Strength Cond Res*. 1997;11:163-167.
20. Guyton AC, Hall JE, *The Textbook of Medical Physiology*. 10th ed. Philadelphia: W.B. Saunders; 2000. p. 823.
21. Hagobian TA, Jacobs KA, Kiratli BJ, Friedlander AL. Foot Cooling Reduces Exercise-Induced Hyperthermia in Men with Spinal Cord Injury. *Med Sci Sports Exer*. 2004;36(3):411-417.
22. Hall CM, Brody LT. *Therapeutic Exercise*. Philadelphia: Lippincott Williams & Wilkins; 2004. P. 188.
23. Hatzel BM, Kaminski TW. The effect of ice immersion on concentric and eccentric isokinetic muscle performance in the ankle. *Isokin and Ex Sci*. 2000;8(2):103-107.
24. Heyward V. *Advanced Fitness Assessment and Exercise Prescription*. 4th Ed. Champaign, IL: Human Kinetics; 2002. p.280-281
25. Hopkins JT, Ingersoll CD, Edwards JE, Klootwyk TE. Cryotherapy and Transcutaneous Electric Neuromuscular Stimulation Decrease Arthrogenic Muscle Inhibition of the Vastus Medialis After Knee Joint Effusion. *J Athl Train*. 2002;37(1):25-32.
26. Howard RL, Kraemer WJ, Stanley DC, Armstrong LE, Maresh CM. The effects of cold immersion on muscle strength. *Journal of Strength Conditioning Research*. 1994;8(3):129-133.
27. Hsu AR, Hagobian TA, Jacobs KA, Attallah H, Friedlander AL. Effects of heat removal through the hand on metabolism and performance during cycling exercise in the heat. *Can J Appl Physiol*. 2005;30(1):87-104.
28. Ikai M, Steinhaus AH. Some factors modifying the expression of human strength. *J Appl Physiol*. 1961;16(1):157-163.
29. Jackson AS, Pollock ML. Generalized equations for predicting body density of men. *Br J Nutr*. 1978;40(3):497-504.
30. Jones SRG. "Was there a Hawthorne effect?" *Am J Sociol*. 1992; 98(3):451-468.

31. Jones LA, Lederman SJ. *Human Hand Function*. New York: Oxford UP; 2006. P. 33.
32. Khomenok GA, Hadid A, Preiss-Bloom O, et al. Hand immersion in cold water alleviating physiological strain and increasing tolerance to uncompensable heat stress. *Eur J Appl Physiol*. 2008;104(2):303-9.
33. Knight, K. L. (1995). *Cryotherapy in Sport Injury Management*. Champaign (IL): Human Kinetics, 1995. p.130-132
34. Kraemer WJ, Gordon SE, Fleck SJ, Marchitelli LJ, Mello R, Dziados JE, Friedl K, Harman E, Maresh C, Fry AC. Endogenous anabolic hormonal and growth factor responses to heavy resistance exercise in males and females. *Int J Sports Med*. 1991;12(2):228-35.
35. Legally KM, McCaw ST, Young GT, Medema HC, Thomas DQ. Ratings of perceived exertion and muscle activity during the bench press exercise in recreational and novice lifters. *J Strength Cond Res*. 2004;18(2):359-64.
36. Lehman GJ. The influence of grip width and forearm pronation/supination on upper-body myoelectric activity during the flat bench press. *J Strength Cond Res*. 2005;19(3):587-91.
37. Livingstone SD, Nolan RW, Cattroll SW. Heat loss caused by immersing the hands in water. *Aviat Space Environ Med*. 1989;60(12):1166-1171.
38. Livingstone SD, Nolan RW, Keefe AA. Heat loss caused by cooling the feet. *Aviat Space Environ Med*. 1995;66(3):232-237.
39. Mattacola CG, Perrin DH. Effects of cold water application on isokinetic strength of the plantar flexors. *Isokinetic Exerc Sci*. 1993;3(3):152-159.
40. Melzack R, Wall PD. Pain Mechanisms; a new theory. *Science*. 1965;150(699):971-979.
41. Newham DJ, Mills KR, Quigley BM, Edwards RH. Pain and fatigue after concentric and eccentric muscle contractions. *Clinical Science*. 1983;64(1):55-62.
42. Nielson B, Nielson M. Body temperature during work. *Scand Arch Physiol*. 1962;56:120-129.
43. Palmieri-Smith, RM, Leonard JL, Garrison JC, Weltman AL, Ingersoll CD. Peripheral joint cooling increases spinal reflex excitability and serum norepinephrine. *Int J Neurosci*. 2007;117(2):229-42.

44. Pierau FK, Wurster RD. Primary afferent input from cutaneous thermoreceptors. *Fed Proc.* 1981;40(14): 2819-24
45. Verducci, FM. Interval cryotherapy and fatigue in university baseball pitchers. *Res Q Exer Sport.* 2001;72(3):280-7.
46. Verducci, FM. Interval cryotherapy decreases fatigue during repeated weight lifting. *J Athl Train,* 2000;35(4):422-426.
47. Welsch EA, Bird M, Mayhew JL. Electromyographic activity of the pectoralis major and anterior deltoid muscles during three upper-body lifts. *J Strength Cond Res.* 2005;19(2):449-452.

CHAPTER IV

SUMMARY, CONCLUSIONS, AND RECOMMENDATIONS

Summary: Hypotheses

Hypothesis I. Total work volume during multiple sets of high intensity bench press exercise will be affected by temperature applied to the hand during the rest periods between sets. Yes. Total work volume of PC was significantly higher than both PH and TN.

Hypothesis II. Cooling the hands between sets alters the EMG response. The surface EMG signals during the first contraction of the 1st set of 85% 1RM will be compared to the last contraction of the 4th set of 85% of 1RM to assess the changes that occur due to fatigue, under the three temperature conditions. Yes. During both eccentric and concentric movements in the lateral head of triceps, the RMS difference during PC was higher than both PH and TN. There were no differences in MF and MDF in any of the muscles during eccentric or concentric contractions. However, PC had higher total repetitions than both PH and TN; therefore, it can be concluded that cooling hands might reduce fatigue.

Hypothesis III.

Core temperature, measured with an esophageal thermistor during the rest periods between sets of high intensity bench press exercise, will be reduced during cooling compared to the thermoneutral and heating conditions associated with an increased number of repetitions. Hand heating will increase core temperature compared to the thermoneutral and cold conditions but will not be associated with more repetitions. Yes.

PC condition had significantly lower mean core temperature than both PH and TN conditions associated with increased endurance. Hand heating had no effect on endurance.

Hypothesis IV. Heart rate and the subjective perception of fatigue using a rating of perceived exertion (RPE) scale will be reduced during sets 2-4 in the cooling condition compared to the thermoneutral and heating conditions. Yes. The ergogenic effect of palm cooling can also be seen in our study by the reduced HR and RPE ratings during sets 2-4 in the PC condition. These physiological data may support that the data were not affected by a Hawthorne effect.

Summary: Unique Contributions

The review manuscript titled “Effect of Local Cooling on Short-Term, Intense Exercise” made a unique contribution to Exercise Physiology by providing a summary of twenty one original investigations involving cooling before short-term, intensive exercise. The manuscript provided the effect of local cooling on muscular performance and mechanisms by which cooling might reduce or increase fatigue. Special emphasis was placed on the potential mechanisms by which palm cooling may exert an ergogenic action.

The research manuscript titled “Effect of Palm Temperature on Fatigue During High Intensity Bench Press Exercise” was an effort to further explore what we believed was the most likely ergogenic effect of palm temperature. The manuscript contributed to Exercise Physiology by providing evidence that palm temperature impacts muscular performance during high intensity bench press exercise. This study was unique in that it

was the first to examine the effect of palm temperature on muscular performance in trained subjects. It also utilized substantially stronger subjects than any other studies. Further, it is one of only a few studies to date that have utilized esophageal temperature measuring and surface EMG to investigate claims of performance enhancement through palm cooling.

Conclusions

Palm cooling with RTX between sets of high intensity bench press exercise resulted in increased repetitions to exhaustion and a greater exercise volume as well as lower heart rates and RPE during exercise. This improvement in training volume may have resulted from a greater recruitment of muscle fibers from the lateral head of triceps, and may have involved a delayed central fatigue or a peripheral counter-irritation effect caused by output from hand thermal receptors. These results suggest that palm cooling may provide an ergogenic effect to enhance the training response of progressive resistive exercise.

Recommendations

We concluded that cooling hands might reduce fatigue because palm cooling during bench press exercise can lead to a greater motor recruitment and can delay fatigue. Therefore, it may allow a greater training volume and thus a more efficient training response. It is recommended that future research examines the effect of palm cooling during a 4 week mesocycle strength training program using 4 sets of 85% of 1RM with 3 minutes rest periods.

LIST OF REFERENCES

1. ACSM. ACSM's Guidelines for Exercise Testing and Prescription, 8th ed. Philadelphia (PA): Lippincott, Williams & Wilkins, 2010.
2. Asmussen, E, and Boje, O. Body temperature and capacity for work. *Acta Physiol Scand* 10: 1-22, 1945.
3. Baechle, TR, and Earle, R. Essentials of strength training and conditioning. 2nd ed. Champaign, IL: Human Kinetics, 2000.
4. Bergersen, TK. A search for arteriovenous anastomoses in human skin using ultrasound Doppler. *Acta Physiol Scand* 147(2): 195-201, 1993.
5. Bigland-Ritchie, B, Donovan, EF, and Roussos, CS. Conduction velocity and EMG power spectrum changes in fatigue of sustained maximal efforts. *J Appl Physiol* 51: 1300-1305, 1981.
6. Binzoni, T, Springett, R, Dalton, JC, and Delpy, D. A new combined deep-body-temperature/NIRs probe for noninvasive metabolic measurements on human skeletal muscle. *Adv Exp Med Biol* 471: 623-629, 1999.
7. Burke, DG, Macneil, SA, Holt, LE, Mackinnon, NC, and Rasmussen, RL. The effect of hot or cold water immersion on isometric strength training. *J Strength Cond Res* 14: 21-25, 2000.
8. Catlaw, K, Arnold, BL, and Parin, DH. Effect of cold treatment on the concentric and eccentric force velocity relationship of the quadriceps. *Isokinet and Exerc Sci* 5: 157-160, 1996.
9. Clarke RSI, Hellon RF and Lind AR. The duration of sustained contractions of the human forearm at different muscle temperatures. *J Physiol (London)* 143: 454-473, 1958.
10. Cornwall, MW. Effect of temperature on muscle force and rate of muscle force production in men and women. *J Orthop Sports Phys Ther* 20: 74-80, 1994.
11. Cristensen, LV, and Mohamed, SE. Effects of topical cooling on isometric contractions of the human masseter muscles. *Arch oral Biol* 29: 635-639, 1984.
12. Cross, KM, Wilson, RW and Perrin, DH. Functional performance following an ice immersion to the lower extremity, *J Athl Train* 31: 113-116, 1996.

13. Davies, CTM, Mecrow, LL, and White, MJ. Contractile properties of the human triceps surae with some observation on the effects of temperature and exercise. *Eur J Appl Physiol* 49: 255-269, 1982.
14. Davies, CTM, and Young K. Effects of temperature on the contractile properties and muscle power of triceps surae in humans. *J Appl Physiol* 55: 191-195, 1983.
15. Davis, JM, and Fitts, R. Mechanisms of muscular fatigue. In: Roitman JL, ed. ACSM's resource manual for guidelines for exercise testing and prescription. Baltimore: Williams & Wilkins, 1998. pp. 182–188.
16. Day, ML, McGuigan, MR, Brice, G, and Foster, C. Monitoring exercise intensities during resistance training using a session RPE scale. *J Strength Cond Res* 18:353-358, 2004.
17. Di Giulio, C, Daniele, F, and Tipton, CM. Angelo Mosso and muscular fatigue: 116 years after the first congress of physiologists: IUPS commemoration. *Advances in Physiology Education* 30: 51-57, 2006.
18. Deluca, CJ. Myoelectrical manifestations of localized muscle fatigue in humans. *Crit Rev Biomed Eng* 11: 251-279, 1984.
19. Doan, BK, Newton, RU, Marsit, JL, Triplett-McBride, NT, Koziris, LP, Fry, AC, and Kraemer, WJ. Effects of increased eccentric loading on bench press 1RM. *J Strength Cond Res* 16:9-13, 2002.
20. Douris, P, Mckenna, R, Madigan, K, Cesarski, B, Costiera, R and Lu, M. Recovery of maximal isometric grip strength following cold immersion. *J Strength Cond Res* 17: 509-513, 2003.
21. Edwards RH. Human muscle function and fatigue. Human muscle fatigue: physiological mechanisms. In: Ciba Foundation symposium 82; 1992: London: Pitman Medical, 1981. pp.1-18.
22. Evans, TA, Ingersoll, C, and Knight, KL. Agility following the application of cold therapy. *J Athl Train* 30: 231-234, 1995.
23. Fischer, J, Van Luben, BL, Branch, JD, and Pirone, JL. Functional performance following an ice bag application to the hamstrings. *J Strength Cond Res* 23: 44-50, 2009.
24. Gammon, GD, and Starr, I. Studies on the relief of pain by counterirritation. *J Clin Inves* 20: 13-20, 1941.
25. Gardiner, PF. Neuromuscular aspects of physical activity. Champaign, IL: Human Kinetics, 2000.

26. Gibson, H, and Edwards, RH. Muscular exercise and fatigue. *Sports Medicines* 2: 120-32, 1985
27. Giesbrecht, GG, Jamieson, C, and Cahill, F. Cooling hyperthermic firefighters by immersing forearms and hands in 10 degrees C and 20 degrees C water. *Aviat Space Environ Med* 78: 561-7, 2007.
28. Glass, S, and Armstong, T. Eelctromyographical activity of the pectralis muscle during incline and decline bench press. *J Strength Con Res* 11: 163-167, 1997.
29. Grahn, DA, Cao, VH, and Heller, HC. Heat extraction through the palm of one hand improves aerobic exercise endurance in a hot environment. *J Appl Physiol* 99: 972-978, 2005.
30. Grahn, DA, Murray, JV, and Heller, HC. Cooling via one hand improves physical performance in heat-sensitive individuals with multiple sclerosis: a preliminary study. *BMC Neurology* 12: 8-14, 2008.
31. Greenfield, A. The circulation through the skin. In: Handbook of physiology Section 2. Hamilton W, Dow P. Washington, DC American Physiological Society, 1963, pp. 1325-1351.
32. Guyton, AC, and Hall, JE. The Textbook of Medical Physiology (10th ed.). Philadelphia, PA: W.B. Saunder, 2000.
33. Hagobian, TA, Jacobs, KA, Kiratli, BJ, and Friedlander, AL. Foot cooling reduces exercise-induced hyperthermia in men with spinal cord injury. *Med Sci Sports Exerc* 36: 411-417, 2004.
34. Hatzel, BM, and Kaminski, TW. The effect of ice immersion on concentric and eccentric isokinetic muscle performance in the ankle. *Isokinet and Exerc Sci* 8: 103-107, 2000.
35. Haymes EM, and Rider RA. Effects of leg cooling in peak ioskinetic torque and endurance. *AM Corr Ther J* 37: 109-115, 1983.
36. Heyward V. Advanced Fitness Assessment and Exercise Prescription. 4th Ed. Champaign, IL: Human Kinetics, 2002.
37. Holewijn, M, and Heus, R, Effects of temperature on electromyogram and muscle function. *Eur J Appl Physiol Occup Physiol* 65: 541-545, 1992.
38. Hopkins, JT, Ingersoll, CD, Edwards, JE, and Klootwyk, TE. Cryotherapy and transcutaneous electric neuromuscular stimulation decrease arthrogenic muscle

- inhibition of the vastus medialis following knee joint effusion. *J Athl Train* 37: 25–32, 2002.
39. Howard, RL, Kreamer, WJ, Stanley, DC, Armstrong, LE, and Maresh, CM. The effects of cold immersion on muscle strength. *J Stength and Cond Res* 8: 129-133, 1994.
 40. Hsu, AR., Hagobian, TA, Jacobs, KA, Attallah, H, and Friedlander, AL. Effects of heat removal through the hand on metabolism and performance during cycling exercise in the heat. *Can J Appl Physiol* 30: 87-104, 2005.
 41. Ikai, M, and Steinhaus, AH. Some factors modifying the expression of human strength. *J Appl Physiol* 16: 157-163, 1961.
 42. Jackson, AS, and Pollock, ML. Generalized equations for predicting body density of men. *Br J Nutr* 40: 497-504, 1978.
 43. Jones LA, Lederman SJ. Human Hand Function. New York: Oxford UP, 2006.
 44. Jones, SRG. "Was there a Hawthorne effect?" *Am J Sociol* 98: 451-68, 1992.
 45. Johnson, DG, Hayward, JS, Jacobs, TP, Collis, ML, Eckerson, JD, and Williams, RH. Plasma norepinephrine responses of man in cold water. *J Appl Physiol* 43: 216-220, 1977.
 46. Khomenok, GA, Hadid A, Preiss-Bloom, O, Yanovich, R, Erlich, T, Ron-Tal, O, Peled, A, Epstein, Y, and Moran, DS. Hand immersion in cold water alleviating physiological strain and increasing tolerance to uncompensable heat stress. *Eur J Appl Physiol* 104: 303-309, 2008.
 47. Kimura, IF, Gulick, DT, and Thmpson, GT. The Effect of Cryotherapy on Eccentric Plantar Flexion Peak Torque and Endurance. *J Athl Train* 32: 124–126, 1997.
 48. Knight KL. Cryotherapy in Sport Injury Management. Champaign, IL: Human Kinetics, 1995.
 49. Kössler, F, Lange, F, and KÜchler, G. Isometric twitch and tetanic contraction of frog skeletal muscles at temperatures between 0 to 30 degrees C. *Biomed Biochim Acta* 46: 809-813, 1987.
 50. Kraemer, WJ, Gordon, SE, Fleck, SJ, Marchitelli, LJ, Mello, R, Dziados JE, Friedl K, Harman, E, Maresh, C, and Fry, AC. Endogenous anabolic hormonal and growth factor responses to heavy resistance exercise in males and females. *Int J Sports Med* 12: 228-35, 1991.

51. Legally, KM, McCaw, ST, Young, GT, Medema, HC, and Thomas, DQ. Ratings of perceived exertion and muscle activity during the bench press exercise in recreational and novice lifters. *J Strength Cond Res* 18:359-64, 2004.
52. Lehman, GJ. The influence of grip width and forearm pronation/supination on upper-body myoelectric activity during the flat bench press. *J Stength Cond Res* 19: 587-91, 2005.
53. Livingstone, SD, Nolan, RW, and Cattroll, SW. Heat loss caused by immersing the hands in water. *Aviat Space Environ Med* 60: 1166-1171, 1989.
54. Livingstone, SD, Nolan, RW, and Keefe, AA. Heat loss caused by cooling the feet. *Aviat Space Environ Med* 66: 232-237, 1995.
55. Marino, FE. Methods, advantages, and limitations of body cooling for exercise performance. *Br J Sports Med* 36: 89-94, 2002.
56. Marsh, RL. Deactivation rate and shortening velocity as determinants of contractile frequency. *Am J Phyiol* 259: 223-30, 1990.
57. Mattacola, CG, and Perrin, DH. Effects of cold water application on isokinetic strength of the plantar flexors. *Isokin and Ex Sci* 3: 152-159, 1993.
58. McMaster, W. Crotherapy, *Phys Sports Med* 10: 112-119, 1982.
59. Melzack, R, and Wall, PD. Pain Mechanisms; a new theory. *Science* 150: 971-979, 1965.
60. Montgomery, JC, and Macdonald, JA. Effects of temperature on nervous system: implications for behavioral performance. *Am J Physiol* 259: 191-6, 1990.
61. Mosso, A. La Fatica. Milano: Treves, 1891.
62. Neuhäuser-Berthold, M, Beine, S, Verwied, SC, and Lührmann, PM. Coffee consumption and total body water homeostasis as measured by fluid balance and bioelectrical impedance analysis. *Ann Nutr Metab* 41: 29-36, 1997.
63. Newham, DJ, and Mills, KR, Quigley, BM, and Edwards, RH. Pain and fatigue after concentric and eccentric muscle contractions. *Clinical Science* 64: 55-62, 1983.
64. Nielsen, B, and Nielson, M. Body temperature during work at different environmental temperatures. *Acta Physiol Scand* 56: 120-129, 1962.

65. Noakes, TD, St Clair Gibson, A. and Lambert, EV. From catastrophe to complexity: a novel model of integrative central neural regulation of effort and fatigue during exercise in humans. *Br J Sports Med* 38: 511-514, 2004.
66. Palmieri-Smith, RM, Leonard, JL, Garrison, JC, Weltman, AL, and Ingersoll, CD. Peripheral joint cooling increases spinal reflex excitability and serum norepinephrine. *International Journal of Neuroscience* 117:229-242, 2007.
67. Patterson, SM, Undermann, BE, Doberstein, ST, and Reineke DM. The effects of cold whirlpool on power, speed, agility, and range of motion. *J Sp Sci Med* 7: 387-934, 2008.
68. Pierau, FK, and Wurster, RD. Primary afferent input from cutaneous thermoreceptors. *Fed Proc* 40: 2819-2824, 1981.
69. Prentice, W.E. An electromyographic analysis of the effectiveness of heat or cold and stretching for inducing relaxing in injured muscle. *J Orthop Sports Phys Ther* 3:133-140, 1982.
70. Ranatunga, KW, and Wylie, SR. Temperature effects on mammalian muscle contraction. *Biomed Biochim Acta* 48: 530-5, 1989.
71. Richendollar, ML, Darby, LA, and Brown, TM. Ice bag application, active warm-up, and 3 measures of maximal functional performance. *J Athl Train* 41: 364-370, 2006.
72. Rome, LC. Influence of temperature on muscle recruitment and muscle function in vivo. *Am J Physiol* 259: 210-222, 1990.
73. Ruiz, DH, Myrer, JM, Durrant, E, and Fellingham GW. Cryotherapy and sequential exercise bouts following cryotherapy on concentric and eccentric strength in the quadriceps. *J Athl Train* 28: 320-323, 1993.
74. Silber, ML. Scientific facts behind creatine monohydrate as sport nutrition supplement. *J Sports Med Phys Fitness* 39: 179-88, 1999.
75. Stinner, JN, and Hartzler, LK. Effect of temperature on pH and electrolyte concentration in air-breathing ectotherms. *J Exp Biol* 203: 2065-2074, 2000.
76. Sundelin, G, and Hagberg, M. Electromyographic signs of shoulder muscle fatigue in repetitive arm work paced by the Methods-Time Measurement system. *Scand J Work Environ Health* 18:262-8, 1992.
77. Thornely, LJ, Maxwell, NS, and Cheung SS. Local tissue temperature effects on peak torque and muscular endurance during isometric knee extension. *Eur J Appl Physiol* 90: 588-594, 2003.

78. Verducci, FM. Interval cryotherapy decreases fatigue during repeated weight lifting. *J Athl Train* 35: 422-426. 2000.
79. Verducci, FM. Interval cryotherapy and fatigue in university baseball pitchers. *Res Q Exer Sport* 72: 280-287. 2001.
80. Volek, JS, Kraemer, WJ, Bush, JA, Boetes, M, Incledon, T, Clark, KL, and Lynch, JM. Creatine supplementation enhances muscular performance during high-intensity resistance exercise. *J Am Diet Assoc* 97:765-70, 1997.
81. Weir, JP, Beck, TW, Cramer, JT, and Housh, TJ. Is fatigue all in your head? A critical review of the central governor model. *Br J Sports Med* 40: 573-586, 2006.
82. Welsch, EA, Bird, M, and Mayhew, JL. Electromyographic activity of the pectoralis major and anterior deltoid muscles during three upper-body lifts. *J Strength Cond Res* 19: 449-452, 2005.
83. Williams, JH. Caffeine, neuromuscular function and high-intensity exercise performance. *J Sports Med Phys Fitness* 31: 481-489.
84. Yanagisawa, O, Niitsu, M, Takahashi, H, Goto, K, and Itai, Y. Evaluations of Cooling Exercised Muscle with MR Imaging and 31P MR Spectroscopy. *Med. Sci Sports Exerc* 35: 1517-1523, 2003.
85. Yoshizumi, WM, Tsourounis, C. Effects of creatine supplementation on renal function. *J Herb Pharmacother* 4: 1-7, 2004.

LIST OF APPENDICES

- A. Informed Consent
- B. Health History Questionnaire
- C. Modification of the category ratio rating of perceived exertion scale

APPENDIX A: INFORMED CONSENT

The University of New Mexico Health Sciences Center Consent to Participate in Research

The Effect of Temperature on Muscle Fatigue During Repeated Bench Press Exercises

Purpose and General Information

You are being asked to participate in a research study that is being done by Suzanne Schneider, Ph.D, who is the Principal Investigator, Dr. Rob Robergs Ph.D, Dr. Burke Gurney Ph.D., and Young Sub Kwon. M.S. This research is being done to evaluate the effect of temperature on muscle fatigue during bench press exercises. You are being asked to participate because you are healthy, between the ages of 18-39 years and do not have high blood pressure or a previous history of muscle or bone injuries of your upper body. Additionally you are being asked to participate because you engage in regular in weight training for at least two years. Approximately 24 subjects locally will take part in this study at the University of New Mexico.

This form will explain the study to you, including the possible risks as well as the possible benefits of participating. This is so you can make an informed choice about whether or not to participate in this study. Please read this Consent Form carefully. Ask the investigators or study staff to explain any words or information that you do not clearly understand.

What will happen if I participate?

If you agree to be in this study, you will be asked to read and sign this Consent Form. After you sign the Consent Form, the following things will happen:

All the testing will take place in the Exercise Physiology lab in Johnson Center, Room B-143, UNM.

When scheduling takes place, you will be asked to refrain from using caffeine and alcohol for 24 hours before each testing session.

Day 1: Screening process, paperwork, 1repetition max (1RM) test, and 85% of 1RM (1hour)

- You will complete this informed consent and the Health Insurance Portability and Accountability Act (HIPPA) form, health history and physical activity questionnaires, and the Physical Activity Readiness Questionnaire (PAR-Q) form.

- If you are a woman, a urine pregnancy test will be performed as part of the screening procedures. The cost of this test will be covered by the study.

- Your blood pressure, height and weight will be measured.

- You will be screened for eligibility for this study based on your answers to the questionnaires and your resting blood pressure. If the criteria are not met, you will be excluded from this study.
- 3 skinfolds will be measured (males: chest, abdomen & thigh, females: arm (triceps), hip & thigh) and the sum of three skinfolds will be used to estimate your percentage of body fat.
- You will be shown how to insert an esophageal probe (this probe measures the temperature of your body by placing a probe into the tube which your food passes from the mouth to the stomach.) for measurement of core temperature. Your nose is first anesthetized with a gel lubricant (with 2% Lidocaine) and some of the gel is placed on the tip of the esophageal probe. The probe is passed through your nose and throat and into the tube which your food passes from the mouth to the stomach tube. The probe is then taped to your nose to hold it in place. For some people placing the esophageal probe is easy and offers little discomfort. Most people experience some sneezing, gagging, and eye tearing, especially when they first learn the technique for placing the probe. Core temperature measurement is not a requirement for this study, so you can still participate if you do not want to insert the esophageal probe.
- You will be asked if you have any soreness or injury to your shoulder, triceps, and chest. and if you have refrained from caffeine and alcoholic beverages in the previous 24 hours.
- Females will be tested during days 3-10 of their menstrual cycle (day 1 is first day of bleeding). If you take oral contraceptives, the test will be done during the days you are taking a pill.

1 Repetition Maximum (RM) test and 85% of 1-RM

-You will do your usual warm-up and will position your hands on the bar with your usual grip. The positions of the smallest fingers of each hand will be marked on the bar to insure the same grip distance on the bar during all tests. The type of grip used (closed or open) will be self-chosen.

-You will be required to perform a warm-up of 10 repetitions at 50% of 1RM, 5 repetitions at 70% of 1RM, 3 repetitions at 80% of 1-RM, and 1 repetition at 90% of 1RM, followed by 3 attempts to determine your 1-RM. You will be given 3 minutes of rest between sets. After the 1-RM test, you will have a 5 minute rest period and then will try to lift as many repetitions as possible using 85% of your 1-RM. If your ratio of weight pushed to body weight is more than or equal to 80% of age based normative value for upper body strength, you will continue to Day 2. If not, you will not be allowed to complete the study.

Day 2 - 4: 85% of 1-RM fatigue tests. These are 3 separate trials on different days (Cooling, heating, thermoneutral (no cooling or heating)), that will take 1 hour each day at approximately the same time each day. The order of the trials will be based on your subject number. There will be 3-5 days between each trial.

- If you decide to use the esophageal probe, you will place the esophageal probe in a private room.

Before your bench press test, gel electrodes will be placed to record muscle electricity on your skin in five places: chest (for females right over the collarbone), shoulder, 2 on the back of the arm (triceps), and on the wrist. The electrode sites will be prepared by shaving (if necessary), abrasion with sandpaper, and swabbing with alcohol prep to lower skin resistance. Each electrode will be secured by adhesive tape. The electrode sites will be marked using an anatomical pen on the skin to ensure the same site was used on different days.

-You will perform a warm-up exactly like that on Day 1. During the rest periods between sets you will be asked to place your hand in a device (RTX) with a metal plate that will be either cold, warm, or room temperature depending on the trial

You will sit on the bench for 3 minutes with the RTX (either warm, cool, or room temperature) applied with a seal around your wrist that feels mildly tight but not constricting. Then you will proceed to the next set of 85% of 1RM. This procedure will continue until you have completed four sets.

Rating of Perceived Exertion (RPE)

During the rest periods you will be asked to answer the question "How was your workout?" to describe your perceived exertion during the each set based on modified 10-RPE scale (0=rest, 10=maximal) which will be explained to you before you start.

Participation in this study will take a total of 4-5 hours over a period of 4 days, each separated by 3-5 days.

What are the possible risks or discomforts of being in this study?

Every effort will be made to protect the information you give us. However, there is a small risk of loss of confidentiality. There are also small risks of stress, emotional distress, and inconvenience.

Some of the risks of weight lifting include soreness of your muscles or muscle injuries. These injuries can be prevented using proper techniques. Weight training injuries occur less often than other sports like basketball or football. Sports injury during weight training has occurred at a rate of about 0.0035 injuries per 100 hours." Every effort will be made to minimize this risk by allowing proper warm-up and having a certified strength and conditioning specialist conducting all of the testing. As with any research, there may be unforeseeable risks.

If you become pregnant, the treatments and procedures in this research may involve risks to the embryo or fetus that are currently unforeseeable. If you should become pregnant, you should immediately notify an investigator and terminate participation.

If you decided to use esophageal probe, you may feel some local discomfort and experience coughing, gagging or eye tearing when you first insert the probe. The only risk from using an esophageal probe is that your throat may be a little sore from local irritation if you had difficulty inserting the probe. There may be potential unforeseen risks of using this probe while bench pressing.

The RTX device itself has been determined by the FDA to be similar to using cooling packs and poses no risk to you.

Emergency equipment (defibrillator and crash cart) are available in the laboratory and emergency procedures are established to call for help (a doctor is in an adjacent building about 2 minutes away – in the Student Health Center).

For more information about risks and side effects, contact the Principal Investigator, Suzanne Schneider, Ph.D.

How will my information be kept confidential?

Your name and other identifying information will be maintained in locked files, available only to authorized members of the research team, for the duration of the study. For any information entered into a computer, the only identifier will be a unique study identification (ID) number. Any personal identifying information and any record linking that information to study ID numbers will be destroyed when the study is completed. Information resulting from this study will be used for research purposes and may be published; however, you will not be identified by name in any publications.

Information from your participation in this study may be reviewed by federal and state regulatory agencies, and by the UNM Human Research Review Committee (HRRC) which provides regulatory and ethical oversight of human research.

What are the benefits to being in this study?

There are no direct benefits to you from being in this study. However, your participation may help answer the question of how body temperature relates to muscle fatigue. These findings could ultimately increase our knowledge related to occupational risks of hot or cold temperatures and their impact on muscle fatigue for workers such as firefighters or military personnel.

What other choices do I have if I don't participate?

Taking part in this study is voluntary so you can choose not to participate.

Will I be paid for taking part in this study?

There will be no compensation.

What will happen if I am injured or become sick because I took part in this study?

No commitment is made by the University of New Mexico Health Sciences Center (UNMHSC) to provide free medical care or money for injuries to participants in this study. If you are injured or become sick as a result of this study, UNMHSC will provide you with emergency treatment, at your cost. It is important for you to tell your study doctor immediately if you have been injured or become sick because of taking part in this study. If you have any questions about these issues, or believe that you have been treated carelessly in the study, please contact the Human Research Review Committee (HRRC) at the University of New Mexico Health Sciences Center, *Albuquerque, New Mexico 87131, (505) 272-1129 for more information.*

Can I stop being in the study once I begin?

Yes. You can withdraw from this study at any time without consequence.

The investigators have the right to end your participation in this study if they determine that you no longer qualify to take part, if you do not follow study procedures, or if it is in your best interest or the study's best interest to stop your participation.

Authorization for Use of Your Protected Health Information (HIPAA)

As part of this study, we will be collecting health information about you. This information is "protected" because it is identifiable or "linked" to you.

Protected Health Information (PHI)

By signing this Consent Document, you are allowing the investigators and other authorized personnel to use your protected health information for the purposes of this study. This information may include: resting blood pressure, height, weight, age, %body fat, and health and fitness related items on the questionnaires.

In addition to researchers and staff at UNMHSC and other groups listed in this form, there is a chance that your health information may be shared (re-disclosed) outside of the research study and no longer be protected by federal privacy laws. Examples of this include disclosures for law enforcement, judicial proceeding, health oversight activities and public health measures.

Right to Withdraw Your Authorization

Your authorization for the use of your health information for this study shall not expire unless you cancel this authorization. Your health information will be used as long as it is needed for this study. However, you may withdraw your authorization at any time provided you notify the UNM investigators in writing. To do this, please send a HIPAA Research Withdrawal Form or letter notifying them of your withdrawal. to:

Suzanne Schneider, Ph.D
sschneid@unm.edu

MSC 04-2610
1 University of New Mexico
Albuquerque New Mexico 87131

Please be aware that the research team will not be required to destroy or retrieve any of your health information that has already been used or shared before your withdrawal is received.

Refusal to Sign

If you choose not to sign this consent form and authorization for the use of your PHI, you will not be allowed to take part in the research study.

What if I have questions or complaints about this study?

If you have any questions, concerns or complaints at any time about the research study, Suzanne Schneider, Ph.D, or her associates will be glad to answer them at 505-277-2658 from Monday to Friday (8am to 5pm). If you would like to speak with someone other than

the research team, you may call the Human Research Review Committee (HRRC) at (505) 272-1129. The HRRC is a group of people from UNM and the community who provide independent oversight of safety and ethical issues related to research involving human subjects.

What are my rights as a research subject?

If you have questions regarding your rights as a research subject, you may call the HRRC at (505) 272-1129 or visit the HRRC website at <http://hsc.unm.edu/som/research/hrrc/>.

Consent and Authorization

You are making a decision whether to participate in this study. Your signature below indicates that you read the information provided (or the information was read to you). By signing this Consent Form, you are not waiving any of your legal rights as a research subject.

I have had an opportunity to ask questions and all questions have been answered to my satisfaction. By signing this Consent Form, I agree to participate in this study and give permission for my health information to be used or disclosed as described in this Consent Form. A copy of this Consent Form will be provided to me.

_____/_____
Name of Adult Participant (print) Signature of Adult Participant Date

I have explained the research to the subject and answered all of his/her questions. I believe that he/she understands the information in this consent form and freely consents to participate.

_____/_____
Name of Research Team Member Signature of Research Team Member/Date

APPENDIX B: HEALTH HISTORY QUESTIONNAIRE

Name _____ D.O.B. / / Date / /
 Age ___ yrs Height ___ cm Weight ___ kg Gender ___ Ethnicity
 Sitting blood pressure _____ / _____ mmHg



MEDICAL HISTORY QUESTIONNAIRE

Section A

1. When was the last time you had a physical examination?

2. If you are allergic to any medications, foods, or other substances, please name them.

3. If you have been told that you have any chronic or serious illnesses, please name them.

4. Give the following information pertaining to the last 3 times you have been hospitalized. Note:
 Women, do not list normal pregnancies.

	Hospitalization	Hospitalization
Reason for hospitalization	_____	_____
Month and year of hospitalization	_____	_____
Hospital	_____	_____
City and state	_____	_____

Section B

During the past 12 months

- | | |
|--|--------|
| 1. Has a physician prescribed any form of medication for you? | Yes No |
| 2. Has your weight fluctuated more than a few pounds? | Yes No |
| 3. Did you attempt to bring about this weight change through diet or exercise? | Yes No |
| 4. Have you experienced any faintness, light-headedness, or blackouts? | Yes No |
| 5. Have you occasionally had trouble sleeping? | Yes No |
| 6. Have you experienced any blurred vision? | Yes No |
| 7. Have you had any severe headaches? | Yes No |
| 8. Have you experienced chronic morning cough? | Yes No |
| 9. Have you experienced any temporary change in your speech pattern, | |

- such as slurring or loss of speech? Yes No
10. Have you felt unusually nervous or anxious for no apparent reason? Yes No
11. Have you experienced unusual heartbeats such as skipped beats or palpitations? Yes No
12. Have you experienced periods in which your heart felt as though it were racing for no apparent reason? Yes No

At present

1. Do you experience shortness or loss of breath while walking with others your own age? Yes No
2. Do you experience sudden tingling, numbness, or loss of feeling in your arms, hands, leg, feet, or face? Yes No
3. Have you ever noticed that your hands or feet sometimes feel cooler than other parts of your body? Yes No
4. Do you experience swelling of your feet and ankles? Yes No
5. Do you get pains or cramps in your legs? Yes No
6. Do you experience any pain or discomfort in your chest? Yes No
7. Do you experience any pressure or heaviness in your chest? Yes No
8. Have you ever been told that your blood pressure was abnormal? Yes No
9. Have you ever been told that your serum cholesterol or triglyceride level was high? Yes No
10. Do you have diabetes? Yes No
If yes, how is it controlled?
- Dietary means Insulin injection
- Oral medication Uncontrolled
11. How often would you characterize your stress level as being high? Yes No
- Occasionally Frequently Constantly
12. Have you ever been told that you have any of the following illness? Yes No
- Myocardial infarction Arteriosclerosis Heart disease Thyroid disease
- Coronary thrombosis Rheumatic heart Heart attack Heart valve disease
- Coronary occlusion Heart failure Heart murmur
- Heart block Aneurysm Angina
13. Have you ever had any of the following medical procedures? Yes No
- Heart surgery Pacemaker implant
- Cardiac catheterization Defibrillator
- Coronary angioplasty Heart transplantation

Section C

Has any member of your immediate family been treated for or suspected to have any of these conditions? Please identify their relationship to you (father, mother, sister, brother, etc.).

- A. Diabetes
- B. Heart disease
- C. Stroke
- D. High blood pressure

Section D

Smoking habits

- 1. Have you ever smoked cigarettes, cigars, or a pipe? Yes No
- 2. Do you smoke presently? Yes No
 - Cigarettes _____ a day
 - Cigars _____ a day
 - Pipefuls _____ a day
- 3. At what age did you start smoking? _____ years
- 4. If you have quit smoking, when did you quit?



PHYSICAL ACTIVITY/EXERCISE QUESTIONARE

- 1. Do you exercise vigorously on a regular basis? Yes No
- 2. What activities do you engage in on a regular basis?
- 3. If you walk, run, or jog, what is the average number of miles you cover each workout?
_____ Miles
- 4. How many minutes on the average is each of your exercise workouts?
- 5. How many workouts a week you participate in on average?
- 6. Do you train weight-lifting? Yes No
- 7. How well trained are you?
- 8. How many workouts a week do you participate weight-lifting in on average?

9. How many years of weight-lifting experience do you have?

10. Do you know your bench press exercise 1 repetitions maximal (RM) weight?

APPENDIX C: MODIFICATION OF THE CATEGORY RATIO RATING OF
PERCEIVED EXERTION SCALE

Rating	Descriptor
0	Rest
1	Very, Very Easy
2	Easy
3	Moderate
4	Somewhat Hard
5	Hard
6	-
7	Very Hard
8	-
9	-
10	Maximal