

5-1-2012

# PREDICTIVE GEOSPATIAL MODELING FOR ARCHAEOLOGICAL RESEARCH AND CONSERVATION: CASE STUDIES FROM THE GALISTEO BASIN, VERMONT AND CHACO CANYON

Wetherbee Bryan Dorshow

Follow this and additional works at: [https://digitalrepository.unm.edu/anth\\_etds](https://digitalrepository.unm.edu/anth_etds)



Part of the [Anthropology Commons](#)

---

## Recommended Citation

Dorshow, Wetherbee Bryan. "PREDICTIVE GEOSPATIAL MODELING FOR ARCHAEOLOGICAL RESEARCH AND CONSERVATION: CASE STUDIES FROM THE GALISTEO BASIN, VERMONT AND CHACO CANYON." (2012). [https://digitalrepository.unm.edu/anth\\_etds/18](https://digitalrepository.unm.edu/anth_etds/18)

This Dissertation is brought to you for free and open access by the Electronic Theses and Dissertations at UNM Digital Repository. It has been accepted for inclusion in Anthropology ETDs by an authorized administrator of UNM Digital Repository. For more information, please contact [disc@unm.edu](mailto:disc@unm.edu).

Wetherbee Bryan Dorshow  
*Candidate*

Department of Anthropology  
*Department*

This dissertation is approved, and is acceptable in quality and form for publication:

*Approved by the Dissertation Committee:*

Wirt Wills, Chairperson

Patricia Crown

Keith Prufer

Timothy Wawrzyniec

\_\_\_\_\_  
\_\_\_\_\_  
\_\_\_\_\_  
\_\_\_\_\_

**PREDICTIVE GEOSPATIAL MODELING FOR  
ARCHAEOLOGICAL RESEARCH AND CONSERVATION:  
CASE STUDIES FROM THE GALISTEO BASIN,  
VERMONT AND CHACO CANYON**

by

**WETHERBEE BRYAN DORSHOW**

B.A., Department of Anthropology, University of Vermont, 1989  
M.A., Department of Anthropology, University of New Mexico, 1996

DISSERTATION

Submitted in Partial Fulfillment of the  
Requirements for the Degree of

**DOCTOR OF PHILOSOPHY  
ANTHROPOLOGY**

The University of New Mexico,  
Albuquerque, New Mexico

May, 2012

## DEDICATION

This dissertation is dedicated to my wife, Alison Chakoumakos,  
my parents, Alice and Bernie Dorshow, and my dog, Forest.

## ACKNOWLEDGEMENTS

I would like to acknowledge and thank all of my committee members for their advice and guidance over the years. They are: Dr. Wirt Wills (Chip), Dr. Patricia Crown (Patty), Dr. Keith Prufer, and Dr. Tim Wawrzyniec. In particular, I am grateful for the support, encouragement and patience of my committee chair, Chip. If it was not for Chip's calm but steady encouragement, I would never have completed this dissertation. Working with Chip and Patty at Chaco over the past six years has reignited my passion for archaeological research, even with the responsibilities and intellectual distractions (shiny bright objects) of my career at Earth Analytic, Inc.

I would like to acknowledge my parents, Alice and Bernie, for instilling in me an unquenchable thirst for learning, knowledge-sharing, and integrity. I would like to acknowledge my wife, Alison Chakoumakos, for her patience, energy, support, and love over these many years of academic pursuit.

I would like to acknowledge Dr. James B. Petersen (Jim) who passed a few years ago while collaborating on ground-breaking research in the Amazon. My long journey to the completion of this dissertation began with Jim.

Finally, I would like to thank the National Center for Airborne Laser Mapping, a National Science Foundation program, for providing high quality LiDAR data for my Chaco research through an NCALM dissertation seed grant.

**PREDICTIVE GEOSPATIAL MODELING FOR  
ARCHAEOLOGICAL RESEARCH AND CONSERVATION:  
CASE STUDIES FROM THE GALISTEO BASIN,  
VERMONT AND CHACO CANYON**

By

Wetherbee Bryan Dorshow

B.A., Department of anthropology, University of Vermont, 1989  
M.A., Department of Anthropology, University of New Mexico, 1996  
Ph.D., Department of Anthropology, University of New Mexico, 2012

**ABSTRACT**

Geospatial modeling of ancient landscapes for predictive scientific research and hypothesis testing is an important emerging approach in contemporary archaeology. This doctoral dissertation is comprised of three published North American case studies that clearly demonstrate the value of predictive geospatial modeling to address explicit goals of contemporary archaeological research, conservation and cultural resource management. The case studies consist of a GIS-based prioritization analysis of natural and cultural resources conservation value in the Galisteo Basin of north-central New Mexico, an archaeological sensitivity analysis (site-discovery potential) for the state of Vermont, and a predictive model of agricultural potential during the Bonito Phase (ca. AD 850 to 1150) in Chaco Canyon, New Mexico. These studies contribute to the growing reliance on quantitative geospatial modeling in the social sciences.

## Table of Contents

List of Figures .....	ix
List of Tables .....	xiii
Chapter 1 - Introduction.....	1
Chapter 2 - Galisteo Watershed Conservation Initiative GIS Analysis Methods and Results.....	4
2.1: Introduction.....	4
2.2: Hierarchical Geoprocessing Model Architecture .....	5
2.3: Design Considerations and Configuration Details.....	6
2.4: Analysis Criteria and Key Parameters .....	9
2.5: Preliminary Data Processing Models.....	15
2.5.1: Hydrologic Data Processing .....	15
2.5.2: Low Road-Density Areas.....	15
2.5.3: Open Space Model.....	15
2.5.4: Soil Data Processing .....	15
2.6: Significant Conservation Model Descriptions.....	20
2.6.1: Scenic Areas Significant Conservation Value Model.....	20
2.6.2: Cultural Resources Significant Conservation Value Toolset .....	26
2.6.3: Habitat Quality Significant Conservation Value Toolset .....	31
2.6.4: Water Resources Significant Conservation Value Toolset.....	33
2.6.7: Significant Conservation Value Wrap-up Model .....	41
2.7: Significant Conservation Value Exploration Toolset .....	48
2.7.1: Easement Target SCV Exploration Tool .....	48
2.7.2: Parcel Zonal Statistics SCV Exploration Tool .....	48
2.8: GWCI Green Infrastructure Query Examples .....	52

Chapter 3 – The Vermont Archaeological Sensitivity Model .....	55
3.1: Modeling Archaeological Sensitivity in Vermont with ArcGIS .....	55
3.2: Vermont Archaeological Sensitivity Model Description and User’s Guide.....	61
3.2.1: Introduction.....	61
3.2.2: General Instructions.....	62
3.2.3: Data Preparation Geoprocessing Tools.....	65
3.2.4: Statewide Default Scenario Toolbox and Analysis Environment Settings.....	75
3.2.5: Statewide Toolset Geoprocessing Model Descriptions .....	76
3.2.6: Exploring Statewide Archaeological Sensitivity Model Results .....	82
Chapter 4 - Modeling Agricultural Potential in Chaco Canyon during the Bonito Phase: A Predictive Geospatial Approach.....	86
4.1: Introduction.....	86
4.2: Methods .....	89
4.2.1: Study Area Delineation.....	90
4.2.2: Elevation .....	90
4.2.3: Soils .....	92
4.2.4: Synthetic Hydrologic Modeling.....	92
4.2.5: Archaeological Site Data .....	94
4.3: Natural Agricultural Suitability Analysis .....	96
4.3.1: Slope Component Geoprocessing Model .....	99
4.3.2: Soil Texture Component Geoprocessing Model.....	99
4.3.3: Depth to Bedrock Component Geoprocessing Model .....	103
4.3.4: Flow Length to Escavada Wash Component Geoprocessing Model.....	105
4.3.5: Overbank Flooding Potential Component Geoprocessing Model .....	107
4.3.6: Drainage Proximity and Flow Potential Component Geoprocessing Model	108



4.3.7: Natural Agricultural Suitability Composite Geoprocessing Model.....	112
4.4: Arable Lands Cultural Enhancement Feasibility Analysis .....	118
4.4.1: Pot-Watering Feasibility Component Geoprocessing Model .....	120
4.4.2: Field Management Feasibility Component Geoprocessing Model.....	123
4.4.3: Nutrient Addition Feasibility Component Geoprocessing Model .....	123
4.4.4: Arable Lands Cultural Enhancement Feasibility Composite Geoprocessing Model .....	124
4.5: Estimating Maximum Maize Yields from Potentially Arable Lands .....	128
4.6: Estimating Water Availability for Potentially Arable Lands.....	129
4.6.1: Sufficient Water Scenario 1 .....	132
4.6.2: Sufficient Water Scenario 2 .....	132
4.7: Conclusions.....	133
Chapter 5 - Conclusions.....	135
5.1: Galisteo Basin .....	135
5.2: Vermont .....	139
5.3: Chaco Canyon.....	147
5.4: Discussion.....	156
References Cited .....	160

## List of Figures

Figure 1-1: Map of Case Study Locations .....	1
Figure 1-2: Chaco Natural Agricultural Suitability Analysis Example .....	3
Figure 2-1: Galisteo Watershed Location Map.....	8
Figure 2-2: GWCI File Directory Structure.....	10
Figure 2-3: GWCI Toolbox .....	10
Figure 2-4: Hydrologic Data Geoprocessing Model.....	16
Figure 2-5: Low Road Density Geoprocessing Model .....	17
Figure 2-6: Existing Open Space Geoprocessing Model.....	18
Figure 2-7: Soil Data Geoprocessing Model .....	19
Figure 2-8: Scenic Grasslands Component Model .....	22
Figure 2-9: Scenic Riparian Areas Component Model.....	22
Figure 2-10: Scenic Landmark Component Model .....	23
Figure 2-11: Scenic Woodlands Component Model.....	23
Figure 2-12: Scenic Areas Composite Model.....	24
Figure 2-13: Scenic Areas Conservation Value Map .....	25
Figure 2-14: Existing Archaeological and Historical Areas Component Model.....	27
Figure 2-15: Registered Properties and Galisteo APA Sites Component Model .....	27
Figure 2-16: Existing Archaeological and Historical Area Component Model .....	28
Figure 2-17: Registered Properties and Galisteo APA Sites Component Model .....	28
Figure 2-18: Cultural Resources Significant Conservation Value Composite Model .....	29
Figure 2-19: Cultural Resources Conservation Value Map.....	30
Figure 2-20: Animal Species Diversity Component Model .....	34
Figure 2-21: Low Road-Density Piñon-Juniper Woodlands Component Model .....	35
Figure 2-22: Low Road-Density Grasslands Component Model .....	35
Figure 2-23: Low Road Density Forests Component Model.....	36
Figure 2-24: Areas near Semi-permanent Water Component Model.....	36
Figure 2-25: Habitat Quality Significant Conservation Value Composite Model.....	37
Figure 2-26: Habitat Quality Conservation Value Map.....	38
Figure 2-27: Drainage Buffer Component Model .....	39
Figure 2-28: Water Body Component Model .....	42

Figure 2-29: Wetland and Riparian Component Model .....	42
Figure 2-30: Spring Buffer Component Model .....	43
Figure 2-31: Aquifer Recharge Zone Component Model.....	43
Figure 2-32: Water Resources Significant Conservation Value Composite Model .....	44
Figure 2-33: Water Resources Conservation Value Map .....	45
Figure 2-34: GWCI Significant Conservation Value Wrap-Up Model .....	46
Figure 2-35: GWCI Significant Conservation Value Map (SCV SUM) .....	47
Figure 2-36: Target Easement Model .....	49
Figure 2-37: Target Easement Tool Results Example .....	50
Figure 2-38: Parcel Zonal Statistics SCV Exploration Tool Results .....	50
Figure 2-39: Parcel Zonal Statistics SCV Exploration Tool Model .....	51
Figure 3-1: Screenshot of Vermont Archaeological Sensitivity Model map document ...	60
Figure 3-2: VTASM File Directory Structure .....	64
Figure 3-3: VTASM Preprocessing Tools .....	66
Figure 3-4: Soil Data Preparation Model.....	67
Figure 3-5: SSURGO Data Availability Status Map .....	68
Figure 3-6: Flowline Data Preparation Model .....	68
Figure 3-7: Wetlands Data Preparation Model .....	69
Figure 3-8: LiDAR Data Preparation Model .....	69
Figure 3-9: LiDAR Data Coverage.....	70
Figure 3-10: Hydronode Preprocessing Model (Part 1).....	73
Figure 3-11: Hydronode Preprocessing Model (Part 2).....	73
Figure 3-12: Hydronode Preprocessing Model (Part 3).....	74
Figure 3-13: Hydronode Preprocessing Model (Part 4).....	74
Figure 3-14: VTASM Toolbox .....	75
Figure 3-15: Drainage Proximity Model.....	78
Figure 3-16: Water Body Proximity Model.....	78
Figure 3-17: Wetland Proximity Model.....	78
Figure 3-18: Stream-Water Body Confluence Proximity Model.....	79
Figure 3-19: Head of Draw Proximity Model.....	79
Figure 3-20: Stream Confluence Proximity Model .....	79

Figure 3-21: Waterfall Proximity Model .....	80
Figure 3-22: Paleo-Lake Soils Presence Model.....	80
Figure 3-23: Kame Terrace or Glacial Outwash Soils Presence.....	80
Figure 3-24: Floodplain Soils Presence Model.....	83
Figure 3-25: Level Terrain Presence Model .....	83
Figure 3-26: Vermont Archaeological Sensitivity Model .....	84
Figure 3-27: VTASM Zonal Statistics Model .....	85
Figure 3-28: VTASM Zonal Statistics Model Results Example .....	85
Figure 4-1: Project Location Map (Regional Context).....	91
Figure 4-2: Synthetic Hydrological Terrain Geoprocessing Model .....	93
Figure 4-3: Drainages and Catchments in the Chaco Core Study Area.....	95
Figure 4-4: Slope Agricultural Suitability Analysis Results.....	101
Figure 4-5: Soil Texture Agricultural Suitability Analysis Results.....	102
Figure 4-6: Depth to Bedrock Agricultural Suitability Analysis Results .....	104
Figure 4-7: Flow Length to Escavada Wash Agricultural Suitability Analysis Results.	106
Figure 4-8: Overbank Flooding Potential Analysis Results .....	109
Figure 4-9: Drainage Proximity and Flow Potential Analysis Results .....	111
Figure 4-10: Natural Agricultural Suitability Analysis Results.....	113
Figure 4-11: Natural Agricultural Suitability by Catchment .....	114
Figure 4-12: Pot-Watering Feasibility Agricultural Suitability Analysis Results .....	122
Figure 4-13: Cultural Field Management Feasibility Analysis Results .....	125
Figure 4-14: Cultural Nutrient Addition Feasibility Analysis Results .....	126
Figure 4-15: Arable Lands Cultural Enhancement Feasibility Composite Analysis Results .....	127
Figure 4-16: Estimated maximum maize yield variability across contiguous zones of “potentially arable” land. Callout label values, which correspond with the pour points listed in Table 4-13, are estimated upstream drainage area in hectares.....	130
Figure 5-1: Vermont Environmental Predictive Model Form .....	143
Figure 5-2: Vermont Archaeological Sensitivity Analysis, Winooski Watershed .....	144
Figure 5-3: Screenshot of the DHP ArcheoMap Application. ....	146
Figure 5-4: Sites with Probable Agricultural Components (ca. AD 840 – 1200).....	148

Figure 5-5: Extent of LiDAR Dataset Obtained through NCALM Grant (Dorshow 2009) .....	152
Figure 5-6: Temperature Regime Risk Analysis Results.....	153
Figure 5-7: Catastrophic Flooding Risk, Incised Scenario .....	154
Figure 5-8: Catastrophic Flooding Risk, Aggraded Scenario .....	155

## List of Tables

Table 2-1: GWCI Significant Conservation value Criteria Matrix.....	11
Table 4-1: Natural Agricultural Suitability Analysis Summary .....	97
Table 4-2: Soil Texture Classification Schema .....	100
Table 4-3: Depth to Bedrock Classification Scheme .....	103
Table 4-4: Drainage Proximity and Flow Potential Agricultural Suitability Classification .....	110
Table 4-5: Natural Agricultural Suitability Analysis Summary .....	114
Table 4-6: Observed, Expected, and Adjusted Residuals Derived from Chi Square Analysis of Natural Agricultural Suitability Score by Catchment.....	115
Table 4-7: Observed, Expected, and Adjusted Residuals Derived from Chi Square Analysis of Natural Agricultural Suitability Variation by Chaco Wash Catchment Groups .....	116
Table 4-8: Observed, Expected, and Adjusted Residuals from Chi Square Analysis of Natural Agricultural Suitability Variation by North, South and Escavada Catchment Groups.....	117
Table 4-9: Observed, Expected, and Adjusted Residuals Derived from Chi Square Analysis of Natural Agricultural Suitability Variation across Great House Presence/Absence Catchment Groups .....	117
Table 4-10: Bonito Phase Residential/Agricultural Site Frequency Variation across Natural Agricultural Suitability Classes .....	118
Table 4-11: Arable Lands Cultural Enhancement Feasibility Analysis Criteria Matrix	120
Table 4-12: Arable Lands Cultural Enhancement Feasibility Analysis Summary .....	124
Table 4-13: Sufficient Water Scenario Analysis .....	131
Table 5-1: Case Study Themes .....	157

## CHAPTER 1 - INTRODUCTION

Geospatial modeling of ancient landscapes for predictive scientific research and hypothesis testing is an important emerging theme in contemporary archaeology. As predicted by Kvamme (1999) over a decade ago, recent advances in geographic information systems (GIS) software, computing and network technologies, and increased availability of high resolution geospatial data have dramatically expanded capabilities for empirical archaeological analysis. Barton and colleagues (2010:363) point out that a dominant trend in archaeological research over the past 40 years has been to "build a scientific understanding of long-term human change through the cumulative development and replicable, transparent testing of explicit, quantitative models of complex human social and ecological processes". Barton and colleagues (2010) make a compelling argument that despite this early call for a more scientific archaeology focused on modeling and testing dynamic processes (Binford 1962; Flannery 1968), it is only recently that archaeologists have been afforded the tools and data necessary to effectively develop these types of models for explicit hypothesis testing at large scales and at high resolution.

In addition to advancing archaeology as a quantitative, scientific discipline, this type of modeling clearly enhances efforts to locate, evaluate, manage and conserve cultural resources. In some cases, the central objective of a predictive geospatial landscape model is to establish an empirical framework for delineating defensible resource conservation priorities, rather than testing a theory-driven hypothesis. In this scenario, the weighted overlay of well-supported, pre-defined empirical criteria (i.e. criteria that are geospatially tractable and that will stand up to public, private and governmental review and

interaction) can yield a suitability map that predicts the relative potential for success in protecting specific lands in the face of real-world development pressures.

As such, I suggest that predictive geospatial modeling in archaeology will become an increasingly prevalent standard operating procedure in archaeological research and cultural resource management.

This doctoral dissertation provides three North American case studies that clearly demonstrate the value of predictive geospatial modeling to address explicit goals of contemporary archaeological research, conservation and cultural resource management. The case studies, all of which are published works of which I am sole author, consist of a GIS-based prioritization analysis of natural and cultural resources conservation value in the Galisteo Basin of north-central New Mexico, an archaeological sensitivity analysis (site-discovery potential) for the state of Vermont, and a predictive model of agricultural potential during the Bonito Phase (ca. AD 850 to 1150) in Chaco Canyon, New Mexico (Figure 1-1).





Figure 1-1: Map of Case Study Locations

These studies entail archaeological and environmental GIS simulations of both ancient and modern landscapes, providing a testable, empirical foundation for both advanced archaeological research and cultural resources conservation prioritization in the face of rapid development.

The Vermont and Galisteo studies were designed to support public policy and education priorities including cultural and natural resources management, conservation, and land-use planning. These two “real-world” (i.e. driven by contractual agreements) cases draw on previous academic research and public policy guidelines to develop scientifically testable geospatial proxies of relative archaeological potential and/or conservation value. These proxies, called suitability surfaces or heat maps, are raster datasets that combine multiple geographic, political and environmental factors through a process known as multi-criteria evaluation modeling (Jankowski 1994; Howey 2007) or weighted overlay analysis (ESRI 2012).

The Chaco study uses multi-criteria overlay analysis of the natural landscape to identify the geographic distribution of potentially arable lands during the 10<sup>th</sup> and 11<sup>th</sup> centuries in the arid Southwestern United States. Based on the Chaco Natural Agricultural Suitability analysis,

Figure 1-2 graphically demonstrates how map layers are overlain in map algebra equations to generate composite suitability surfaces. In this graphic, the highest agricultural potential zones are green (cell value = 5) and lowest potential zones are red (cell value = 1). The layer at the bottom of the stack represents the algebraic sum of the other weighted factors on a cell-by-cell basis.

Chapters 2 through 4 present adapted versions of the published Vermont, Galisteo, and Chaco works, respectively. Chapter 2 details the methods and results of the Galisteo Watershed Conservation Initiative land conservation priorities GIS analysis I designed and implemented. This chapter comes from an original manuscript I authored for the study (Dorshow 2008), which was subsequently adapted into several chapters and appendices in the final GWCI report (Jansens, et al. 2011). Chapter 3 presents adaptations of two documents I authored on the VTASM development and implementation effort.

The first is a short informative article on the overall project that was published in the 2006 Spring issue of *ArcNews*, a national GIS magazine published by ESRI Press. The second is detailed user guide for the VTASM geospatial toolkit and analysis results GIS database (geodatabase) that was distributed by the Vermont Division for Historic Preservation to cultural resource management staff at a variety of federal, state, and local government agencies and professional consulting archaeology firms licensed by the state of Vermont. Chapter 4 presents the final manuscript, accepted for publication in the *Journal of Archaeological Science* in January of 2012, of the Chaco predictive agricultural potential study (Dorshow, in press), and Chapter 5 presents summaries and discussions for each case study.

This trio of projects, all of which are characterized by multidisciplinary collaboration, reflects the comingling of my experiences as both graduate student and business professional. The studies combine the use of advanced remote sensing and GIS analysis methods with an innovative, multi-disciplinary, and scientific approach to addressing archaeological research problems and cultural resource management issues.

Additionally, these studies share a consistent application of sustainable, non-intrusive research and analysis methodologies, further minimizing the physical and cultural impacts of potentially destructive archaeological investigations. For each case study project, I served as the sole or co- Principal Investigator (PI) and benefitted from substantive support from a variety of collaborators. In addition to similarities in goals and methods, each of the three studies is part of a larger, ongoing, body of collaborative archaeological research, cultural resources management and land-use planning efforts that cross public, private, and academic domains. These and related themes that bind the three studies together are provided in Chapter 5.

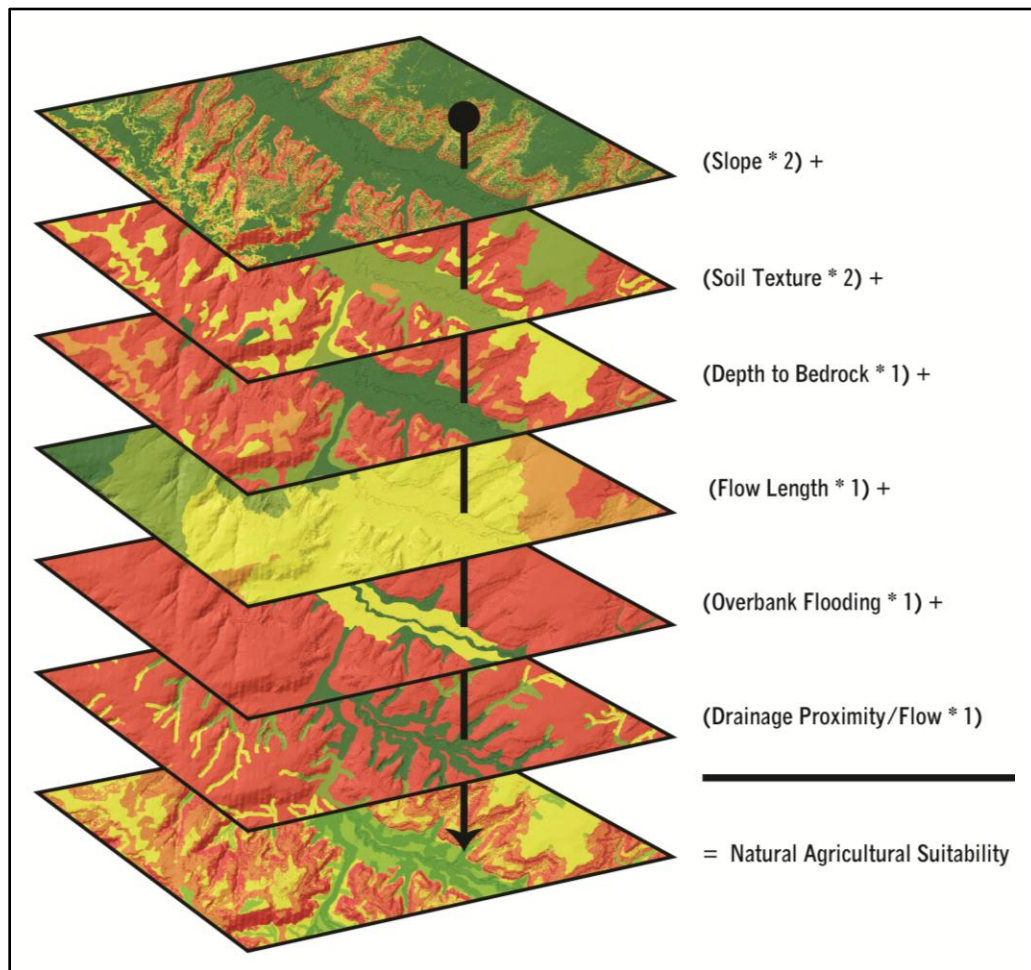

Figure 1-2: Chaco Natural Agricultural Suitability Analysis Example

## CHAPTER 2 - GALISTEO WATERSHED CONSERVATION INITIATIVE GIS ANALYSIS METHODS AND RESULTS

*This chapter is an original manuscript I wrote that was later adapted and published in the Galisteo Watershed Conservation Initiative (GWCI) final report entitled “Galisteo Watershed Conservation Initiative: Quality of Life at a Crossroads” (Jansens et al. 2012). Funded by the New Mexico State Legislature, the GWCI project was a multi-disciplinary, multi-agency collaborative effort to develop a comprehensive natural and cultural resources conservation plan for the Galisteo Basin in north central New Mexico. This study entails a hierarchical, multi-criteria suitability analysis based on four primary “Conservation Priority” criteria: cultural resources, water resources, habitat resources, and scenic resources.*

*In addition to establishing an empirical baseline for land conservation and land-use planning in the face of tremendous development pressures, the “Green Infrastructure” approach embodied in the final report emphasizes the importance of protecting connective pathways between important natural areas and strategies to reduce environmental fragmentation.*

*I was responsible for designing and implementing the complex geospatial analysis on which the Galisteo Green Infrastructure Plan is based, drawing on support and feedback from project stakeholders.*

### 2.1: Introduction

Three of the primary objectives of the Galisteo Watershed Conservation Initiative (GWCI) GIS project, as stated in the original proposal, are as follows:

1. Identify and categorize existing “open space.”
2. Identify undeveloped lands—not including existing open space—having **significant conservation value** and rank these areas in terms of relative conservation value (or conservation priority).
3. Identify undeveloped “marginal lands” (eroded, high-runoff) adjacent to or near existing open space and high-priority conservation targets and rank them in terms of their relative potential to negatively impact the quality of existing open space or potential conservation targets.

The GWCI GIS project successfully addressed objectives 1 and 2. The first geoprocessing model simply identifies and categorizes open space as a single GIS data layer. The second, called the Significant Conservation Value Model (SCVM), is hierarchical, comprised of multiple geoprocessing models, each targeting a specific analytical variable such as biodiversity. Objective 3 was excluded from the GWCI GIS project. The consensus of the GIS Steering Committee and the project sponsors was to focus on the Significant Conservation Value model and putting it to use before rushing to consider the restoration issue. As the published GIS model and toolset is tuned and applied by project stakeholders to identify conservation targets, it will be very straightforward to identify potential buffer and restoration zones through simple maps and GIS methods.

This document summarizes the methods and results of the SCVM. Sections include a description of the SCVM architecture, a synopsis of key GIS analytical concepts, detailed descriptions of the geoprocessing models, maps of the model results, and post-modeling analysis. Figure 2-1 provides a general location map for the project study area.

## **2.2: Hierarchical Geoprocessing Model Architecture**

The SCVM is a GIS-based hierarchical geoprocessing framework built with ESRI's ArcGIS (v.9.2) software with the ArcGIS Spatial Analyst extension. Geoprocessing models are analytic constructs that provide a flowchart interface for exposing sequences of GIS processes along with explicitly defined analysis parameters. Geoprocessing models are easily modified to incorporate new data and to evaluate different analysis parameters, making them useful tools for long-term planning and research. The

geoprocessing model framework is scientifically repeatable and self-documenting; geoprocessing history is stored as metadata.

At the core of the SCVM system is a functionally and thematically organized directory structure for GIS data, ArcMap documents, geoprocessing toolboxes, exported maps, and documentation. The SCVM user interface is an ArcMap document that points to all required model inputs, and a custom toolbox containing several dozen ArcGIS geoprocessing models. Figure 2-2 shows the basic directory structure for inputs, outputs, and other elements of the SCVM.

### **2.3: Design Considerations and Configuration Details**

The SCVM organizational structure, which includes map documents, toolboxes, models, model inputs, and model outputs, is designed to preserve of the default version while at the same time allowing for the exploration of different versions or scenarios. Note that the results presented in this document are based on a “default” version, approved by the GWCI GIS Steering Committee, but subject to refinement in the future.

The SCVM structure takes advantage of the relative path references of ArcGIS 9.2 map documents, toolboxes, and model outputs, allowing the user to make a copy of the entire default scenario folder. By changing the name of new scenario folder and renaming the map document and model toolbox contained therein, the user can open the map document, reset the environment settings as necessary, and then manipulate the models as desired. Importantly, this scenario-building effort does not require duplication of the model input data, which is stored in a folder called ModelInput, located at the same directory level as the root scenario folder.

Geoprocessing environment settings control important analysis parameters. In the SCVM, environment settings are configured at the level of the toolbox, simplifying the process of changing default settings (workspace and scratch space locations, output extent, mask, and cell resolution) for the entire hierarchical geoprocessing model.

For the published run of the SCVM, the following environment settings were used:

- Current Workspace: the ModelInput subfolder in the statewide directory
- Scratch Space: the ModelOutput\Intermediate subfolder in the statewide directory
- Analysis Extent: Same as the raster “GWCI\_Mask”; (HUC12 watershed boundary, buffered by one mile, then rasterized)
- Cell Size: 10 m
- Mask: Same as the raster “GWCI\_Mask”

The SCVM toolbox is subdivided into three primary toolsets: one for preliminary data processing (“Data Preprocessing”), one for the hierarchical basin-wide conservation model, and one for SCVM analysis results assessment and investigation (post-modeling analysis).



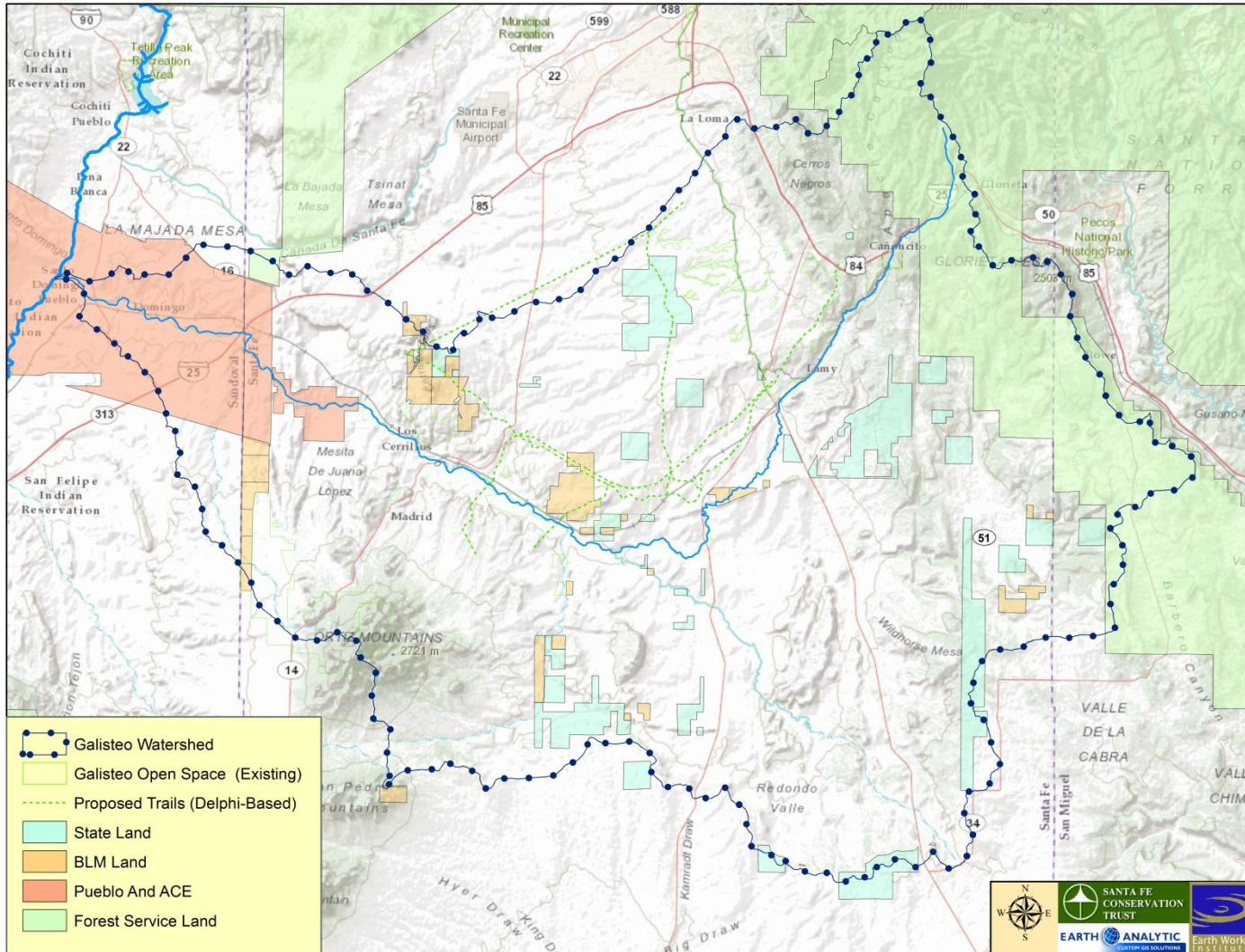

Figure 2-1: Galisteo Watershed Location Map

## 2.4: Analysis Criteria and Key Parameters

The SCVM hierarchy consists of four primary geoprocessing models (flowchart-like analytic constructs) called “Composite Models”:

- Scenic Value
- Cultural Resources Value
- Habitat Value
- Water Value

Composite Models (e.g., overall habitat value) combine the results of two or more secondary geoprocessing models called Component Models (e.g., animal species diversity, low road-density grasslands). The sequence of model implementation for a given thematic category such as scenic value is simple: all Component Models are run first, followed by the Composite Model. The results of the four Composite Models are combined in the SCV Wrap-up Model. The Component Models and the SCV Wrap-up Models generate two raster outputs, one based on a simple sum operation and another based on a weighted sum operation that also reclassifies results into three ordinal classes.

For the current analysis, equal weights were applied to all input criteria for all models. On any given model run, these weights can be adjusted on the fly for use in evaluating different funding and conservation priority scenarios. While the SCV Wrap-up is perhaps most important, each individual Composite Model can be assessed and utilized independently. Importantly, note that these models can be adjusted in many ways, from the vintage or accuracy of input datasets to the classification schemes and parameter settings (e.g., buffer distance, richness value threshold). Figure 2-3 shows the contents of the SCVM toolbox and

Table 2-1 lists analysis criteria, data sources and model weights and ranks for each of the models in the toolbox.

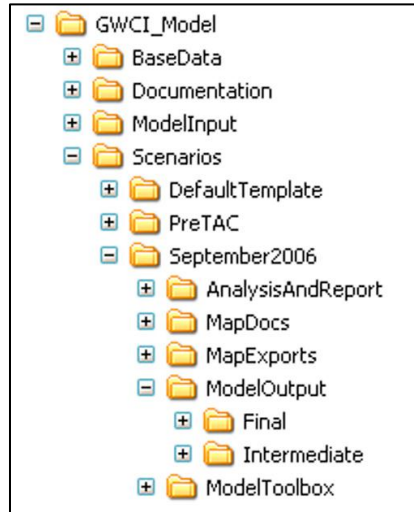

Figure 2-2: GWCI File Directory Structure

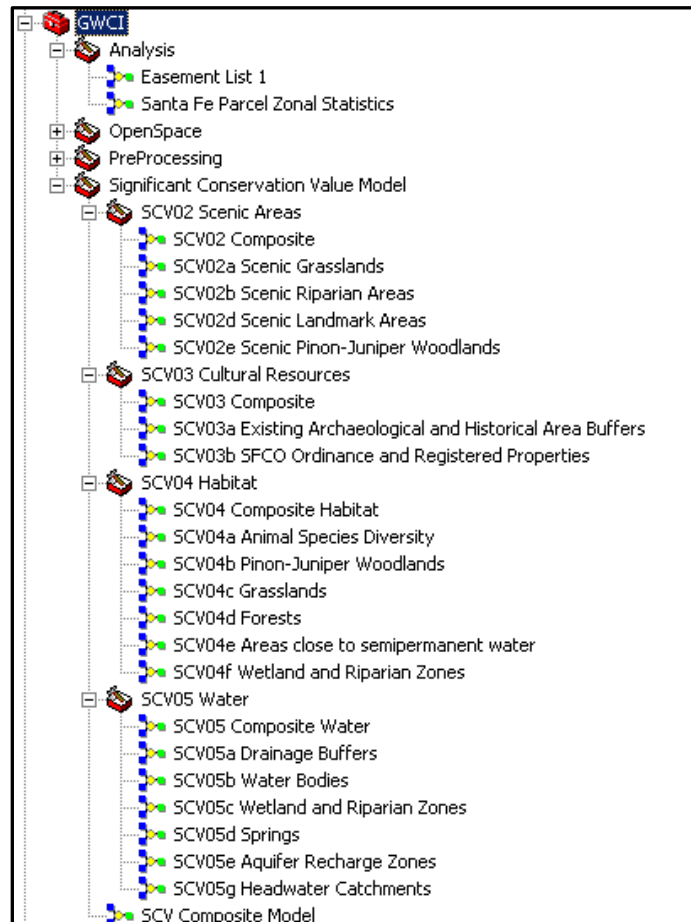

Figure 2-3: GWCI Toolbox

Table 2-1: GWCI Significant Conservation value Criteria Matrix

Model Name	Component Model Criteria	Component Model Ranking Strategy	Component Model Weighting	Metadata	Composite Model Weighting
SCV02a	Scenic grasslands	Criteria Presence: SCV Score = 1	25%	NLCD 2002 and NM GAP Vegetation dataset	25.00%
		Other Lands: SCV Score = 0			
SCV02b	Scenic riparian areas	Criteria Presence: SCV Score = 1	25%	Contact Jan-Willem Jansens for more information on the EWI projects:	
		Criteria Absence: SCV Score = 0			
SCV02e	Scenic piñon-juniper areas	Criteria Presence: SCV Score = 1	25%	NLCD 2002 and NM GAP Vegetation dataset	
		Criteria Absence: SCV Score = 0			
SCV02d	Scenic landmark areas	Criteria Presence: SCV Score = 1	25%	Locations identified by the GWCI Scenic Areas Delphi Group	
		Criteria Absence: SCV Score = 0			
Model SCV02 Composite			100%	All SCV02 component models	
SCV03a	Buffered locations of recorded archaeological or historical sites of demonstrated or potential significance	Criteria Presence: SCV Score = 1	50.00%	New Mexico's Archaeological Records Management System (ARMS)	
		Criteria Absence: SCV Score = 0			
SCV03b	Recorded Archaeological Sites	Criteria Presence: SCV Score = 1,	50.00%	New Mexico's Archaeological Records Management System (ARMS)	
		Criteria Absence: SCV Score = 0			
Model SCV03 Composite			100%	All SCV03 component models	
SCV04a	Presence of high species biodiversity	Criteria Presence: SCV Score = 1	20.00%	The richness data used in this model are derived from the 1996	25.00%

Model Name	Component Model Criteria	Component Model Ranking Strategy	Component Model Weighting	Metadata	Composite Model Weighting
		Criteria Absence: SCV Score = 0		NM Gap vegetation analysis.	
SCV04c	Presence of low road-density grasslands	Criteria Presence: SCV Score = 1	20.00%	See Above	
		Criteria Absence: SCV Score = 0			
SCV04d	Presence of low road-density forests	Criteria Presence: SCV Score = 1	20.00%	See Above	
		Criteria Absence: SCV Score = 0			
SCV04f	Presence of riparian vegetation and wetlands	Riparian Vegetation and Wetlands Presence: SCV Score = 1	20.00%	This model is simply a copy of the output from SCV05c. See the metadata for that output layer and model.	
		Criteria Absence: SCV Score = 0			
SCV04e	Presence of semi-permanent water (excluding wetlands)	Criteria Presence: SCV Score = 1	20.00%	All SCV02 component models	
		Criteria Absence: SCV Score = 0			
Model SCV04 Composite			100%	All SCV04 component models	
SCV05a	Proximity to Drainages	Proximity to Galisteo Creek, NE Segment (above Canoncito), 0 to 50 m: SCV Score = 1;	20%	This model uses the "medium resolution" (1:100,000) scale National Hydrographic Dataset. See <a href="http://www.nhd.gov">www.nhd.gov</a>	25.00%
		Proximity to Galisteo Creek, Cerrillos of Canoncito, 0 to 50 m: SCV Score = 1;			

Model Name	Component Model Criteria	Component Model Ranking Strategy	Component Model Weighting	Metadata	Composite Model Weighting
		Proximity to First Order Tributaries of Galisteo Creek, 0 to 25 m: SCV Score = 1;			
		Proximity to Second Order Tributaries of Galisteo Creek, 0 to 20 m: SCV Score = 1;			
		Proximity to Third Order Tributaries of Galisteo Creek: 0 to 10, SCV Score = 1;			
		Other Areas: SCV Score = 0			
SCV05b	Presence of water bodies	Criteria Presence: SCV Score = 1	20%	This model uses the "medium resolution" (1:100,000) scale National Hydrographic Dataset. See <a href="http://www.nhd.gov">www.nhd.gov</a>	
		Criteria Absence: SCV Score = 0			
SCV05c	Presence of wetlands	Criteria Presence: SCV Score = 1	20%	Three datasets are inputs to this model. Two of the datasets are GPS-based inventories of selected wetlands in the basin: GPS-based (GeoXT, sub-meter) data from 2005-2006 Galisteo Wetland Project and GPS-based (GeoExplorer 3; 1-3 m) data from the 2004 Earth Works Institute Ranch vegetation study. The third dataset consists of probable riparian areas digitized from topos and aerial photos for an infiltration/runoff model created by EWI and Earth Analytic, Inc. in 2004-2005.	
		Criteria Absence: SCV Score = 0			

Model Name	Component Model Criteria	Component Model Ranking Strategy	Component Model Weighting	Metadata	Composite Model Weighting
SCV05d	Presence of springs	Criteria Presence: SCV Score = 1	20%	This model uses the "high res" (1:24,000) scale National Hydrographic Dataset. See <a href="http://www.nhd.gov">www.nhd.gov</a>	
		Criteria Absence: SCV Score = 0			
SCV05e	Presence of aquifer recharge zones	Criteria Presence: SCV Score = 1	20%	The Digital Geologic Map of New Mexico in ARC/INFO Format by Gregory N. Green and Glenn E. Jones <a href="http://rgisedac.unm.edu/metadata/geology/geo0004.txt">http://rgisedac.unm.edu/metadata/geology/geo0004.txt</a>	
		Criteria Absence: SCV Score = 0			
Model SCV05 Composite			100%		
SCVSUM, SCVWSUM, SCVWWSUM				These models employ weighted overlay procedures to combine the four composite models in three ways: Unweighted Sum, Weighted Sum, and Double-Weighted Sum. See text for details.	

## **2.5: Preliminary Data Processing Models**

This section provides descriptions for each of the preliminary data processing (Data Preprocessing) models contained in the SCVM toolkit.

### **2.5.1: Hydrologic Data Processing**

This model (Figure 2-4) combines datasets from three high-resolution NHD geodatabases (13020201, 13050001, 13060001) that overlap the Galisteo Basin. The merged drainage, water body and spring datasets that occur within the HUC12 catchments comprising the Galisteo Basin are selected and merged into three output datasets.

### **2.5.2: Low Road-Density Areas**

This model (Figure 2-5) assigns value of 1 to cells falling within square-mile blocks that have less than one linear mile of paved roads.

### **2.5.3: Open Space Model**

This model (Figure 2-6) generates a polygon dataset comprised of conservation easements held by the Santa Fe Conservations Trust and The Nature Conservancy, parcels in the Santa Fe County database classified as (or known to be) one of the following: common area, park, trail, open space, conservation easement (Eldorado Community Preserve).

### **2.5.4: Soil Data Processing**

Taking three SSURGO datasets as inputs (San Miguel County, Sandoval County, and Santa Fe County), this model (Figure 2-7) selects soil map unit polygons that fall within the project area and merges them into a single dataset for use in other models. The first



step of this process entails the joining of the "MUAGGATT" table (from the SSURGO database) to each input dataset.

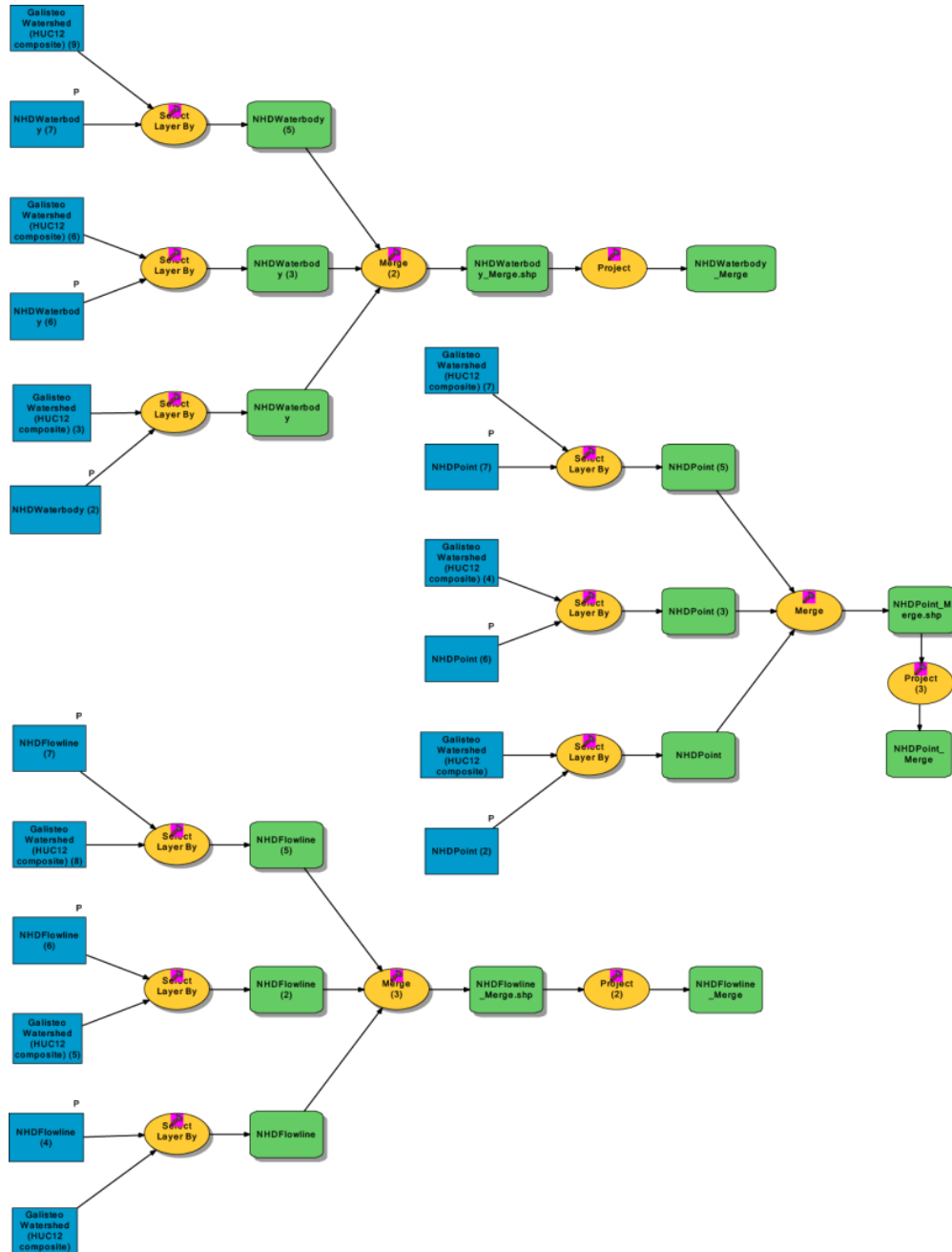

Figure 2-4: Hydrologic Data Geoprocessing Model

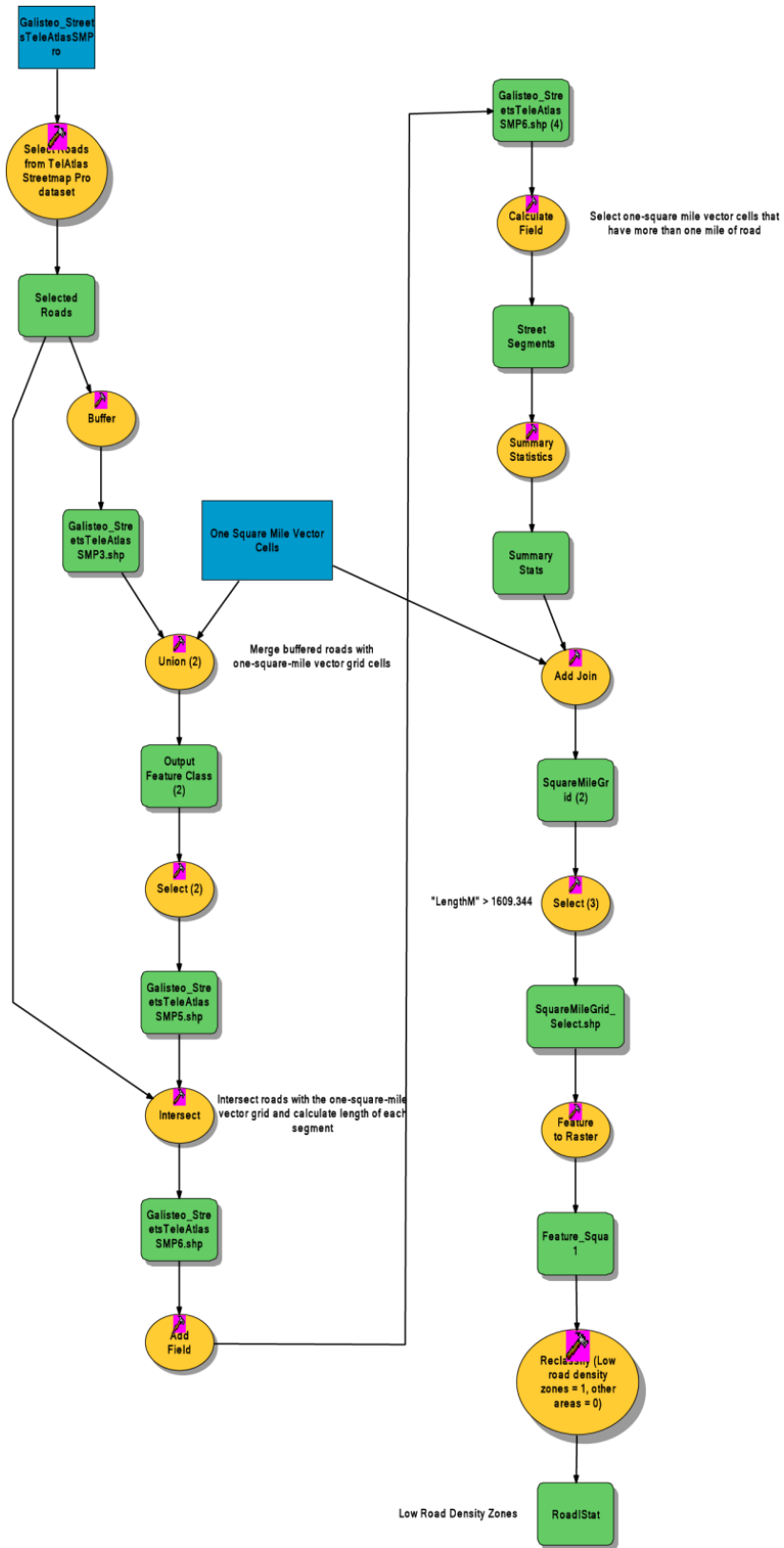

Figure 2-5: Low Road Density Geoprocessing Model

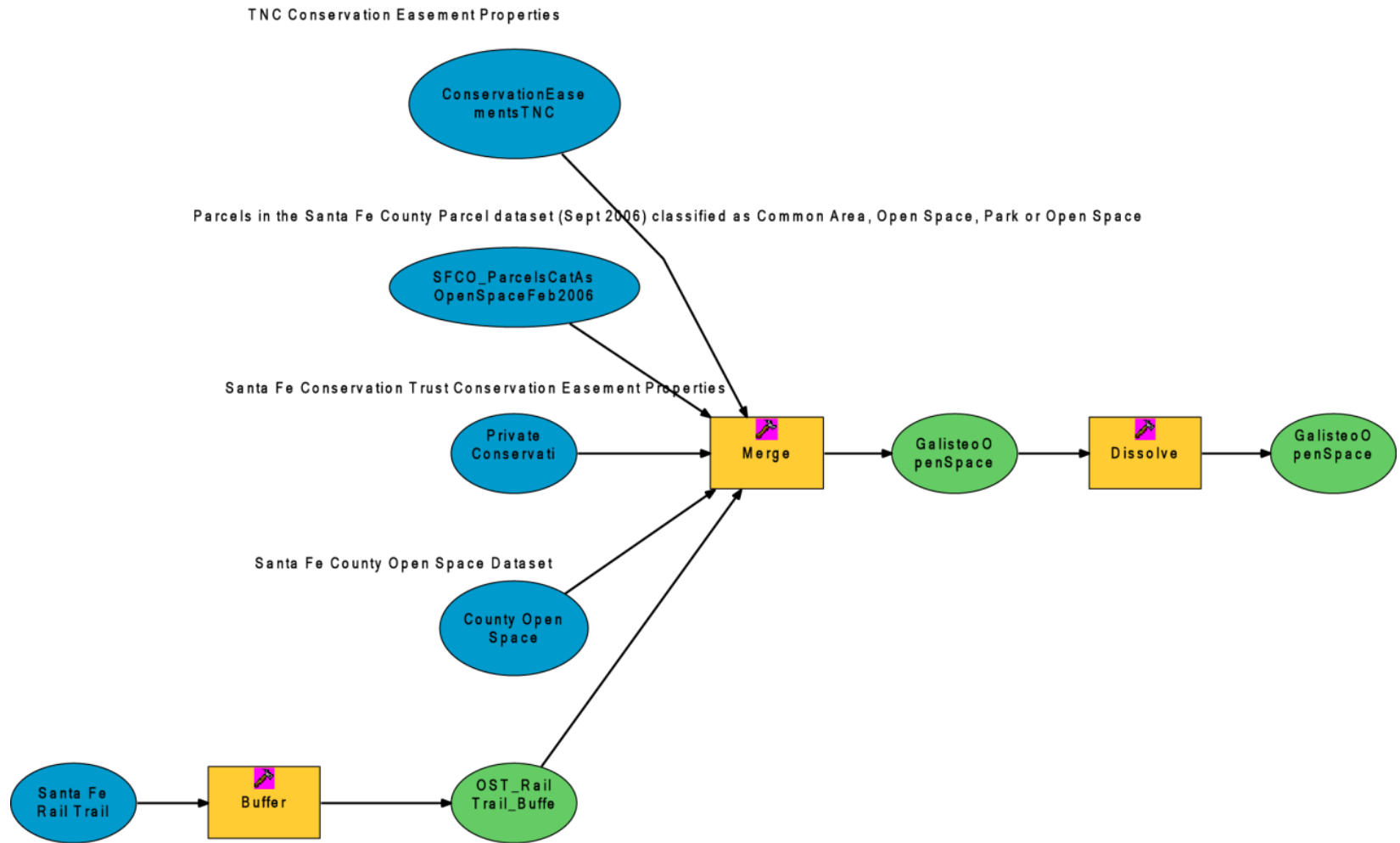

Figure 2-6: Existing Open Space Geoprocessing Model

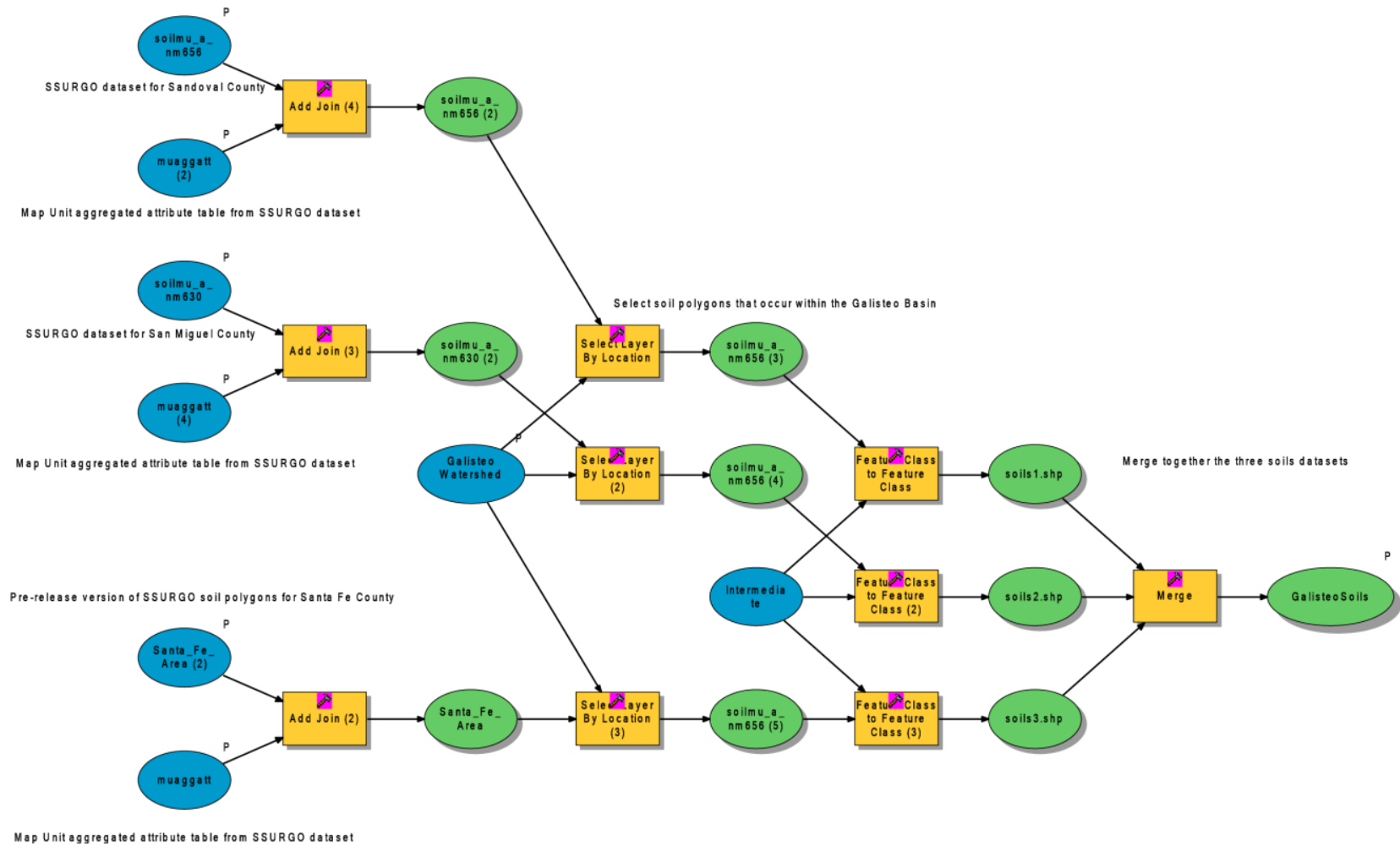

Figure 2-7: Soil Data Geoprocessing Model

## **2.6: Significant Conservation Model Descriptions**

This section provides descriptions for each of the geoprocessing models contained in the SCVM toolkit. Maps showing the conservation priorities analysis results are presented for the four Component Models and the three Wrap-Up Models in the corresponding sections.

### **2.6.1: Scenic Areas Significant Conservation Value Model**

The Scenic Areas Conservation Value Toolset is comprised of four component models and one composite conservation value cost surface.

#### ***2.6.1.1: Scenic Grasslands***

This model (Figure 2-8) selects zones defined as grasslands in the New Mexico GAP vegetation dataset, removing zones classified as developed/disturbed in the NLCD 2002 land use dataset. The output raster assigns a value of one (1) to scenic (undeveloped) grasslands and 0 to all other areas.

#### ***2.6.1.2: Scenic Riparian Areas***

This model (Figure 2-9) converts wetland and riparian vegetation polygons collected with sub-meter GPS equipment during the Earth Works Institute (EWI) Galisteo Wetlands Project inventory (2006) into raster format. In the output raster, wetlands and riparian areas are assigned a value of one (1) and all other areas are assigned a value of 0.

#### ***2.6.1.3: Scenic Landmarks***

This model (Figure 2-10) creates a binary raster in which scenic landmarks and areas have a value of one and all other areas have a value of zero. The input data for this model comes from a variety of reference sources and is based on a qualitative assessment of

what is scenic made by members of the GWCI scenic areas technical advisory group (TAC). Features were extracted using topographic maps, the GNIS (Geographic Named Information System) database, USGS 10m elevation (DEM) and derived slope data, TeleAtlas transportation data, and other data sources.

#### ***2.6.1.4: Scenic Piñon-Juniper Woodlands***

This model (Figure 2-11) selects zones defined as piñon-juniper woodlands in the New Mexico GAP vegetation dataset, removing zones classified as developed/disturbed in the NLCD 2002 land-use dataset. The output raster assigns a value of 1 to scenic (undeveloped) piñon-juniper woodlands and a value of one (0) to all other areas.

#### ***2.6.1.5: Scenic Areas Significant Conservation Value Composite Model***

The composite Scenic Values Model (Figure 2-12 and Figure 2-13) combines the component models in two ways, one based on the sum of input rasters and the other based on a weighted sum process. The unmodified sum of all of the four scenic value rasters results in a layer with values ranging from a minimum of 0 to a maximum of 4. The weighted sum process reclassifies positive output values into three classes of conservation value: moderate, high, very high). Note that for the published release of the GWCI Model, all Scenic Values Component Models were assigned equal weights in the weighted sum analysis.

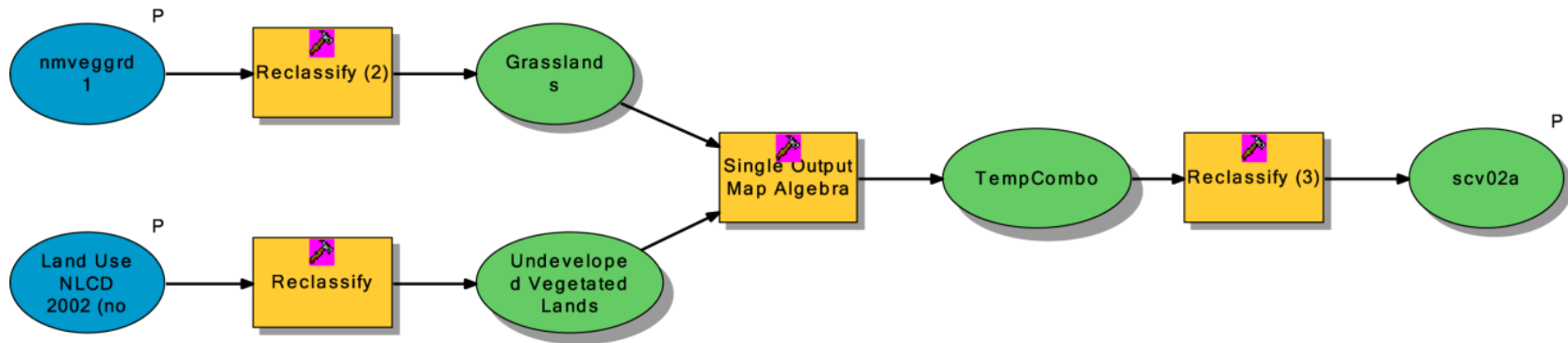

Figure 2-8: Scenic Grasslands Component Model

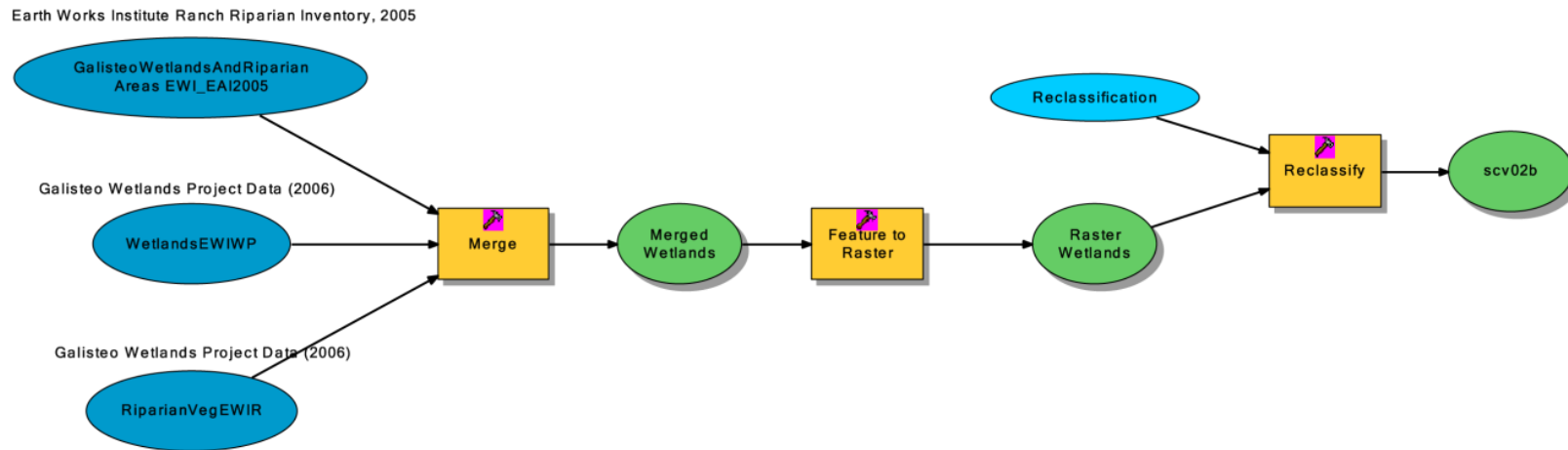

Figure 2-9: Scenic Riparian Areas Component Model

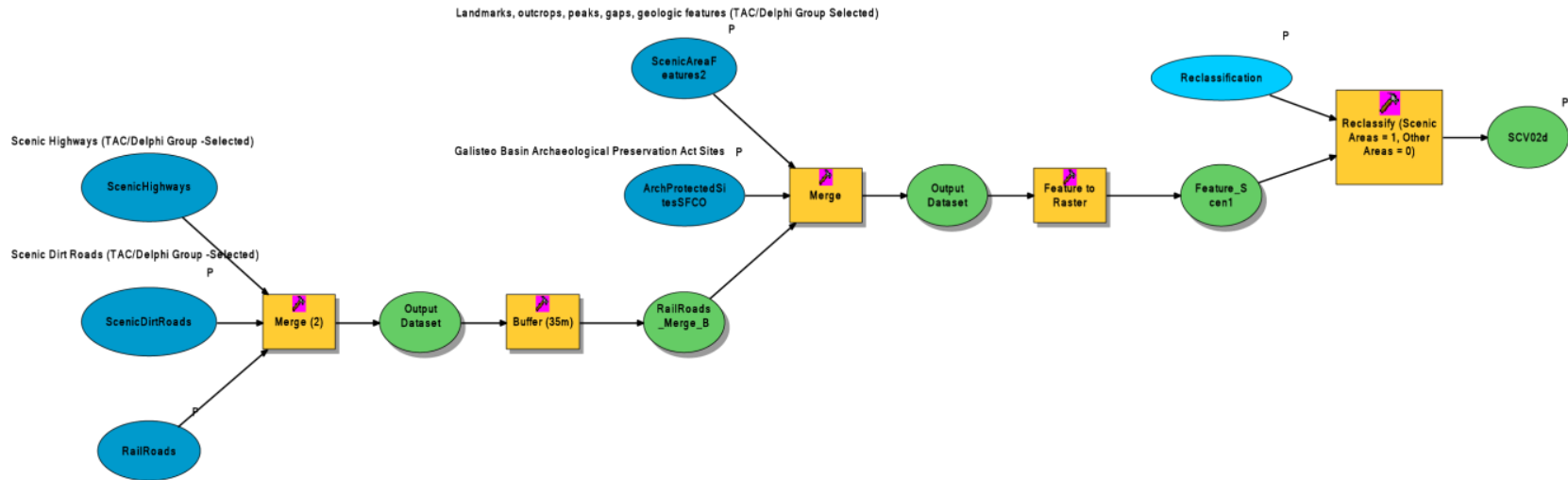

Figure 2-10: Scenic Landmark Component Model

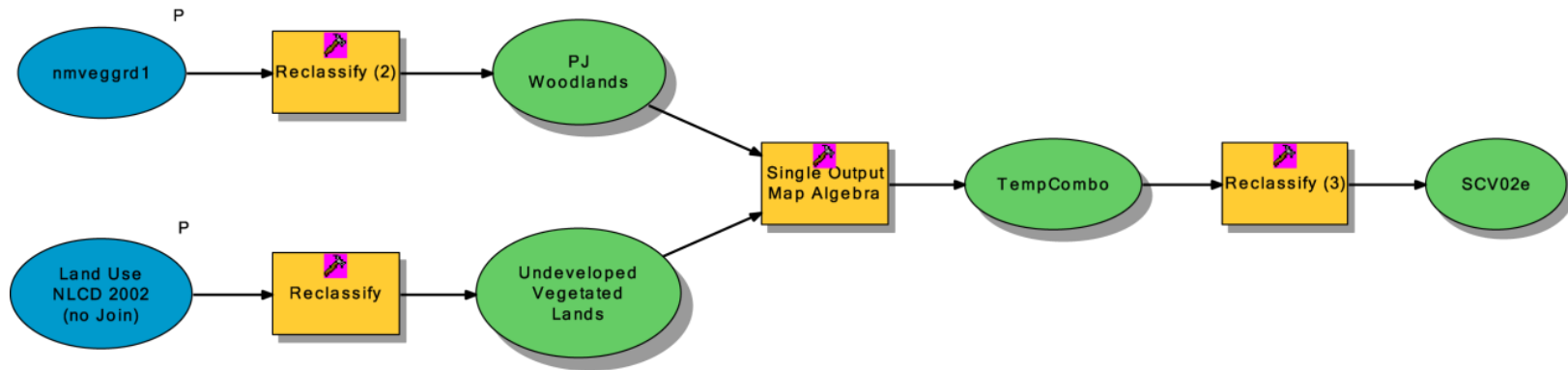

Figure 2-11: Scenic Woodlands Component Model



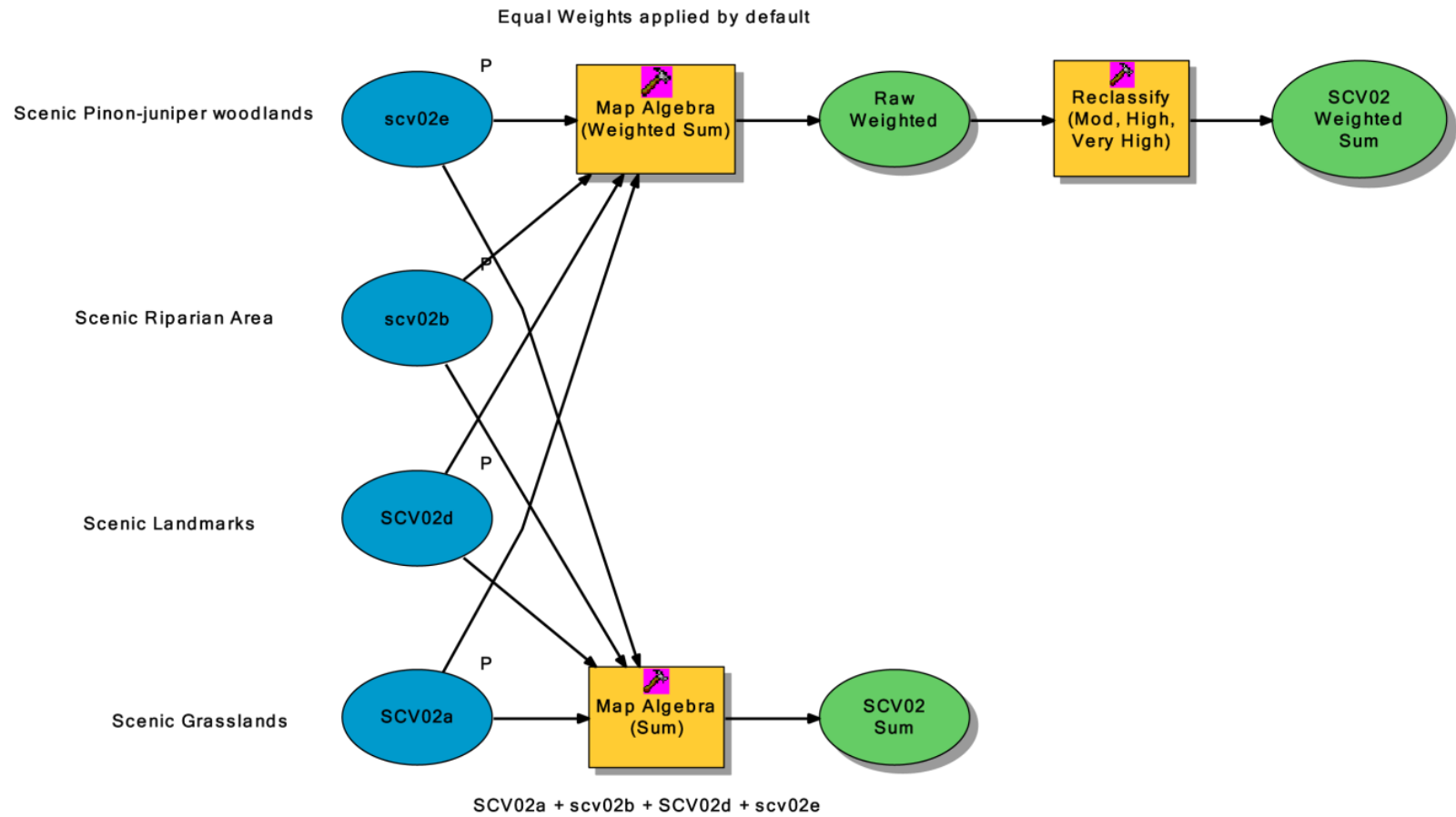

Figure 2-12: Scenic Areas Composite Model

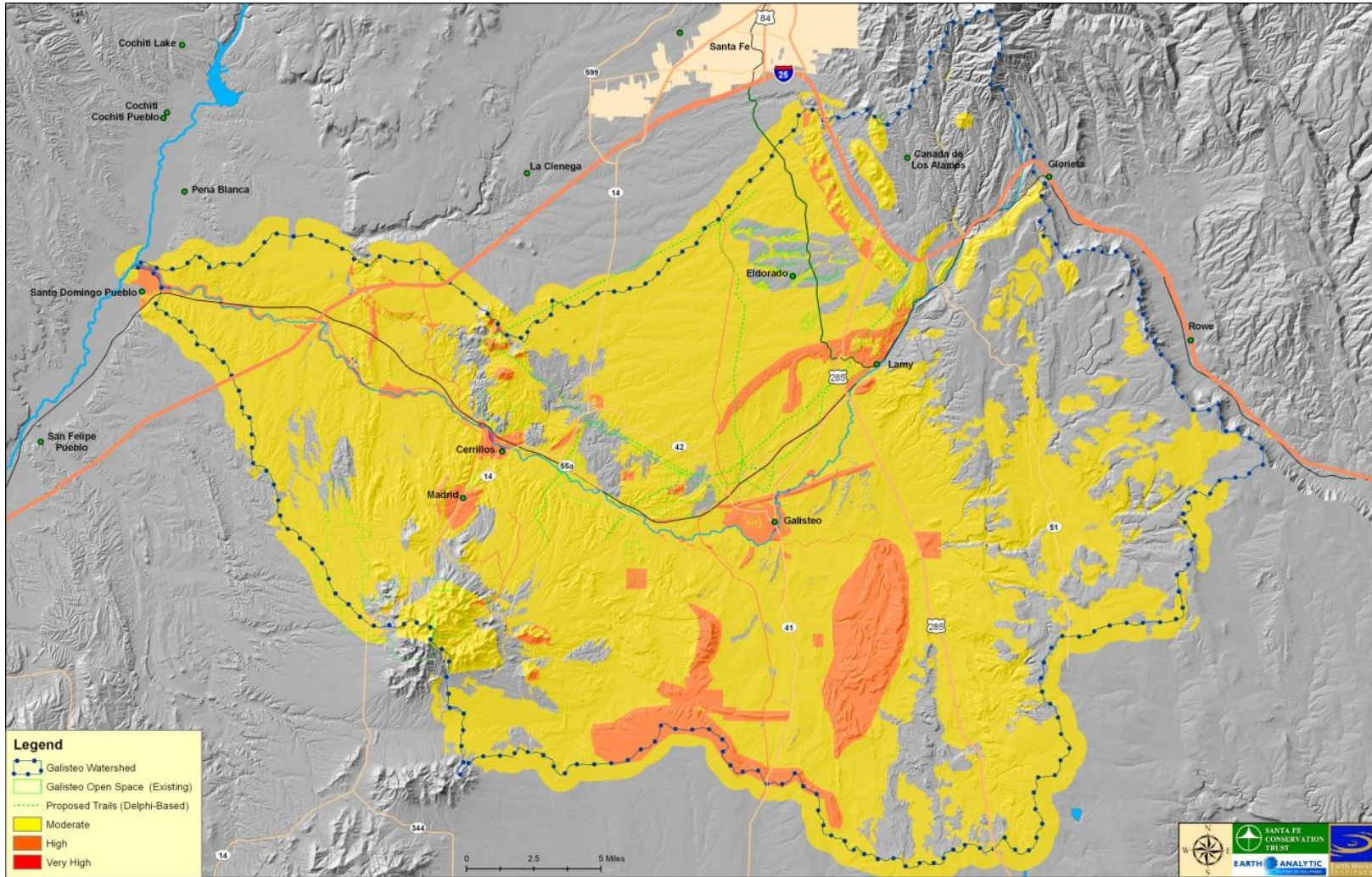

Figure 2-13: Scenic Areas Conservation Value Map

## **2.6.2: Cultural Resources Significant Conservation Value Toolset**

### ***2.6.2.1: Existing Archaeological and Historical Area Buffers***

This model (Figure 2-14) takes four categories of archaeological/historical features, buffers each based on data-specific parameters, merges them together, then creates an output raster in which cells within 200m of the buffered locales are assigned a value of one (1). All other areas are assigned a value of 0 in the output raster.

### ***2.6.2.2: Registered Properties and Galisteo APA Sites***

In this model (Figure 2-15) lands that are (1) currently listed on the National Register of Historic Places or the State Register of Cultural Places, and/or (2) identified as a target for preservation in the Galisteo Basin Sites Protection Act (EDIT), are rasterized and cells within the sensitive areas are assigned a score of one (1). All other cells are assigned a score of zero (0).

### ***2.6.2.3: Cultural Resources Significant Conservation Value Composite Model***

The composite Cultural Resources Value Model (Figure 2-18 and Figure 2-19) combines the component models in two ways, one based on the sum of input rasters and the other based on a weighted sum process. The unweighted sum of the three Scenic Value Component Model rasters results in a layer with values ranging from a minimum of zero (0) to a maximum of three (3). The weighted sum process reclassifies positive output values into three classes of conservation value: moderate, high, very high. Note that for the published release of the GWCI Model, all Cultural Resources Value component models were assigned equal weights in the weighted sum analysis.

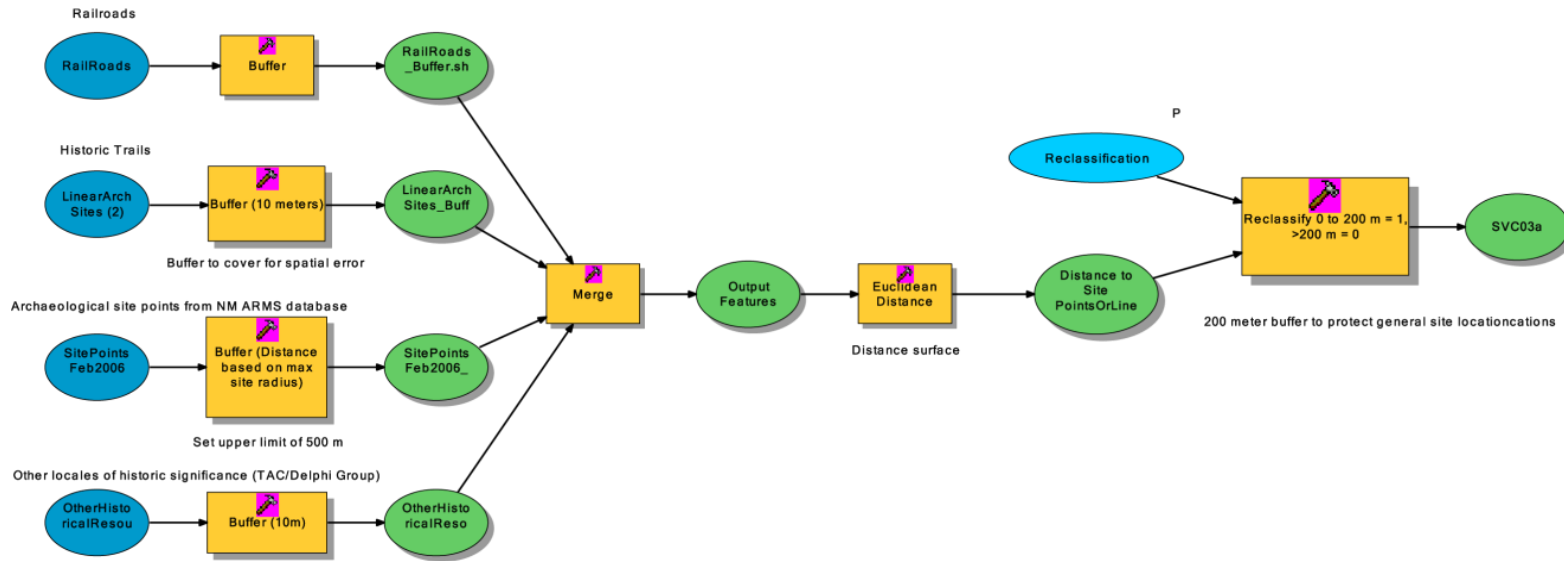

Figure 2-14: Existing Archaeological and Historical Areas Component Model

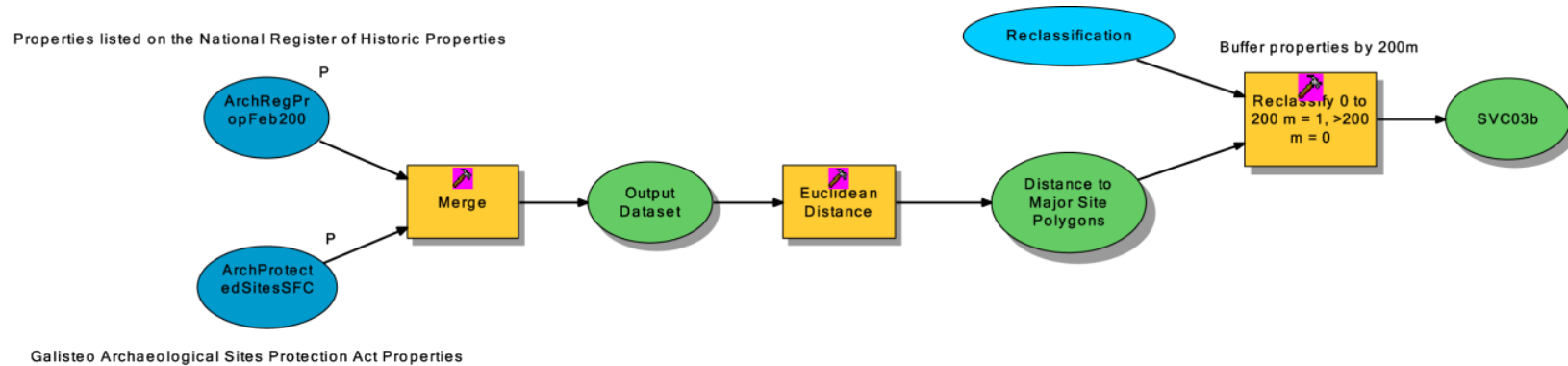

Figure 2-15: Registered Properties and Galisteo APA Sites Component Model

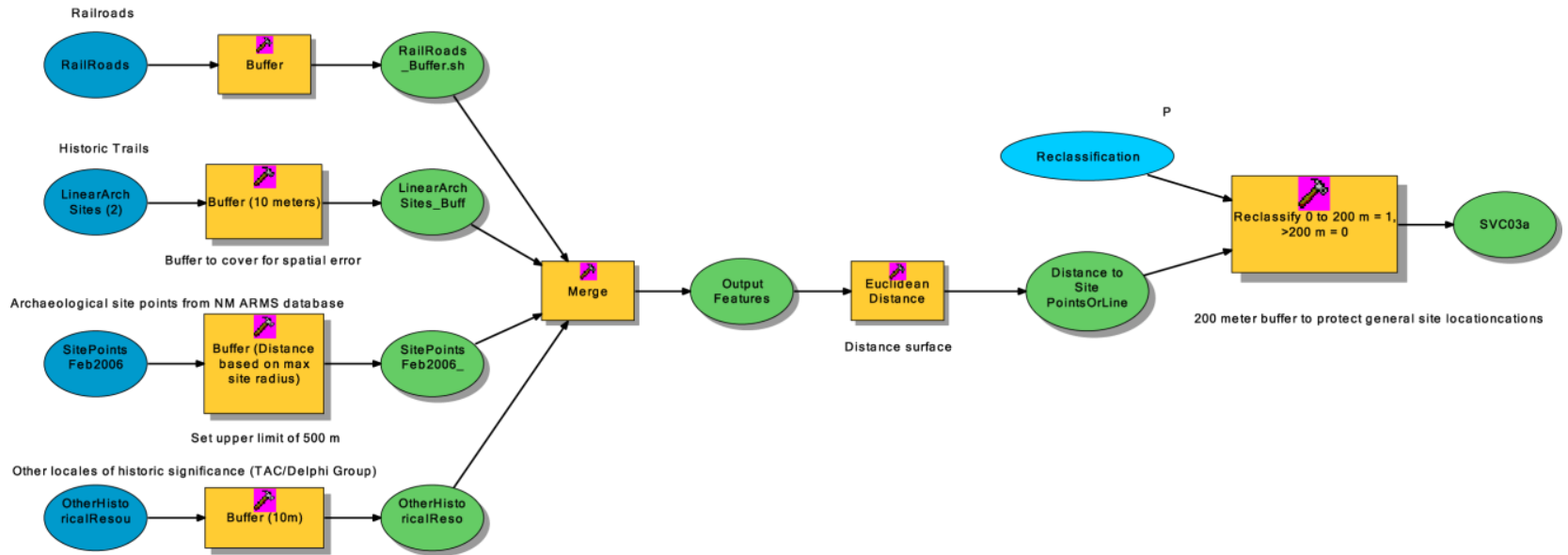

Figure 2-16: Existing Archaeological and Historical Area Component Model

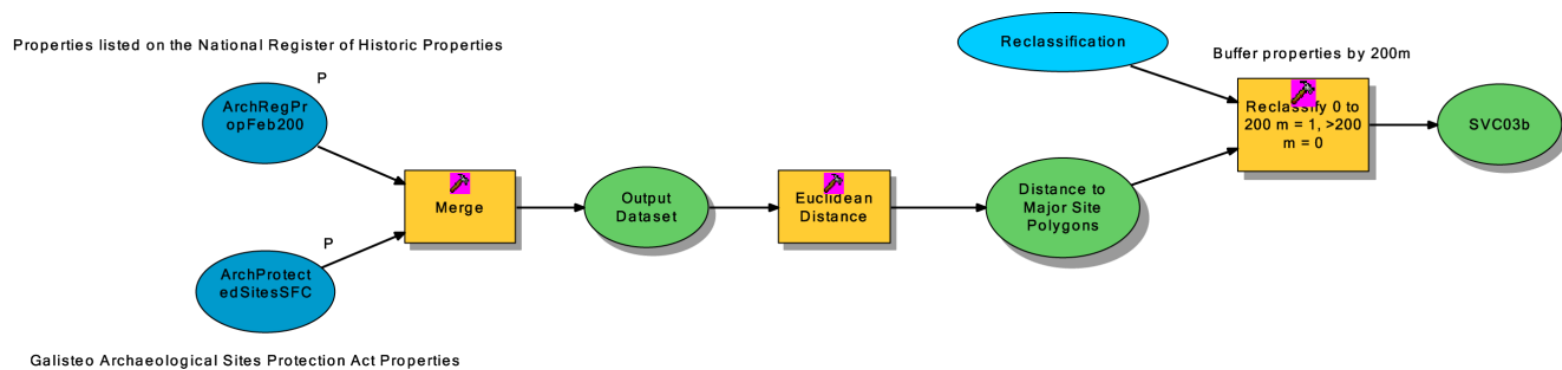

Figure 2-17: Registered Properties and Galisteo APA Sites Component Model

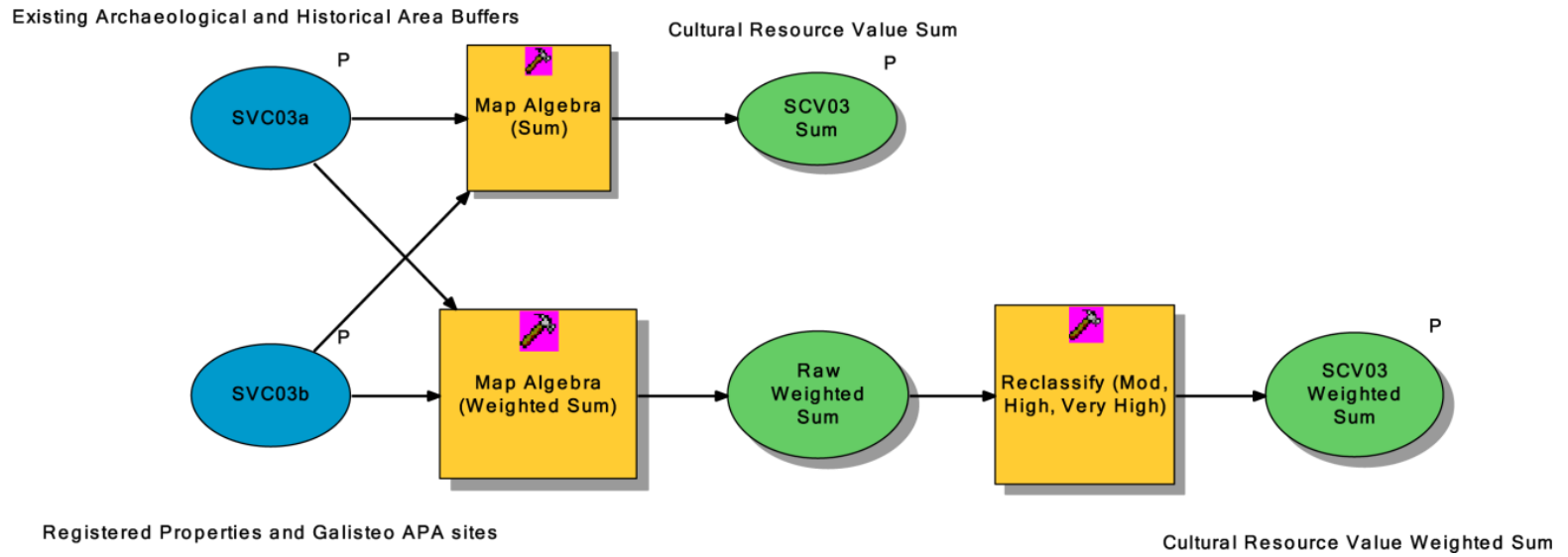

Figure 2-18: Cultural Resources Significant Conservation Value Composite Model

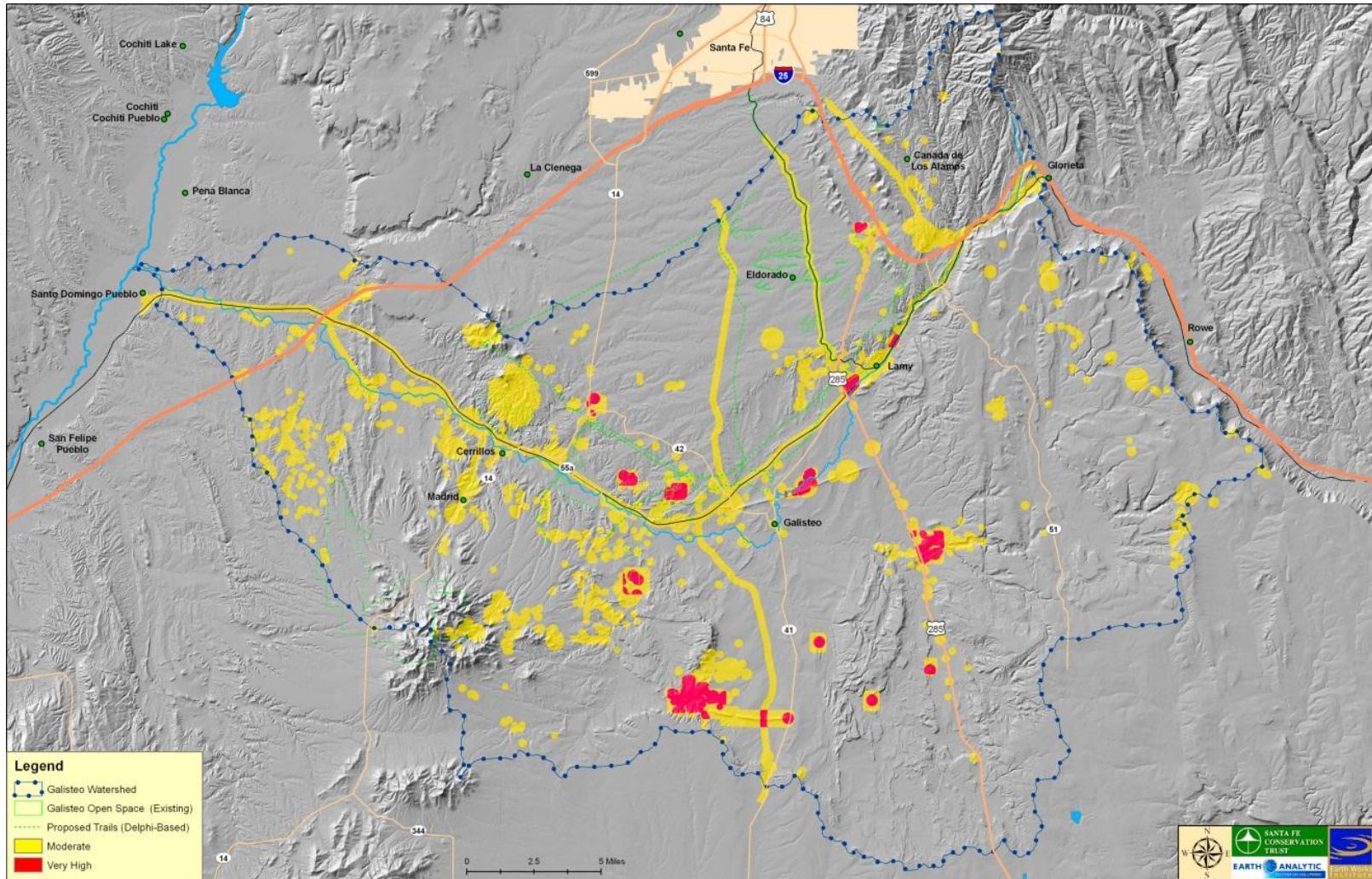

Figure 2-19: Cultural Resources Conservation Value Map

### **2.6.3: Habitat Quality Significant Conservation Value Toolset**

#### ***2.6.3.1: Animal Species Diversity***

This model (Figure 2-20) uses the gap richness analysis result data for each vegetation class represented in the GAP vegetation dataset to generate a raster with three ordinal classes of overall species diversity (low, medium, and high). Given the binary nature of the April 2006 GWCI model run, this variability is parsed into only two classes: high diversity areas, determined by an arbitrary break in richness, are assigned a final output score of one (1), and other zones are assigned the value of zero (0). The richness data used in this model are derived from the 1996 NM Gap vegetation analysis. For more information, refer to the Gap final report and the individual metadata reports for the richness studies in the GWCI metadata folder.

#### ***2.6.3.2: Low Road-Density Piñon-Juniper Woodlands***

This model (Figure 2-21) selects Piñon-Juniper Woodlands from the New Mexico GAP Vegetation analysis, removes developed areas (e.g., high-density residential) indicated by the 2002 National Land Cover Dataset, then assigns a value of one (1) to all PJ Woodland. Areas with more than one (1) linear mile of road per square mile block are excluded from the final output.

#### ***2.6.3.3: Low Road-Density Grasslands***

This model (Figure 2-22) selects grasslands from the New Mexico GAP Vegetation analysis, removes developed areas (e.g., high-density residential) indicated by the 2002 National Land Cover Dataset, then assigns a value of one (1) to all forested lands. Areas



with more than one (1) linear mile of road per square mile block are excluded from the final output.

#### ***2.6.3.4: Low Road-Density Forests***

This model (Figure 2-23) selects forested areas from the New Mexico GAP Vegetation analysis, removes developed areas (e.g., high-density residential) indicated by the 2002 National Land Cover Dataset, then assigns a value of 1 to all forested lands. Areas with more than one (1) linear mile of road per square mile block are excluded from the final output.

#### ***2.6.3.5: Areas near Semi-permanent Water***

This model (Figure 2-24) is a composite of three secondary models in the Water Related Primary Model category SCV 05a (presence of drainages), SCV05b (presence of water bodies) and SCVd (presence of springs). These "wet" areas are assigned a value of one (1) and all other areas are assigned a value of zero (0).

#### ***2.6.3.6: Wetland and Riparian Zones***

This model is simply a copy of the output from SCV05c. Refer to the metadata for that output layer and model.

#### ***2.6.3.7: Habitat Quality Significant Conservation Value Composite Model (SCV04)***

The Habitat Quality wrap-up model (Figure 2-25 and

Figure 2-26) combines the component models in two ways, one based on the sum of input rasters and the other based on a weighted sum process. The non-weighted sum of the five Scenic Value Component Model rasters results in a layer with values ranging from a minimum of zero (0) to a maximum of five (5). The weighted sum process reclassifies

positive output values into three classes of conservation value: moderate, high, very high. Note that for the published release of the SCV Model, all Habitat Quality Component Models were assigned equal weights in the weighted sum analysis.

## **2.6.4: Water Resources Significant Conservation Value Toolset**

### ***2.6.4.1: Drainage Buffers***

Using the NHD vectors and their associated stream level attributes, drainages are selected and buffered in a raster environment as follows: Galisteo Creek, NE Segment (above Cañoncito), 0 to 50 m, SCV Score = 1; Galisteo Creek, Cerrillos to Cañoncito, 0 to 50 m, SCV Score = 1; First Order Tributaries to Galisteo Creek, 0 to 25 m, SCV Score = 1; Second Order Tributaries to Galisteo Creek, 0 to 20 m, SCV Score = 1; Third Order Tributaries to Galisteo Creek, 0 to 10, SCV Score = 1; Other drainages, SCV Score = 0.

The results of the final GWCI model run (Figure 2-27) uses the 1:100,000 scale National Hydrographic Dataset. The 1:24,000 scale version of the NHD was released after the model was created. Unfortunately, the stream level attribute of the higher resolution dataset is not populated at this time. This attribute is necessary to automate the buffering thresholds specified by the model.

### ***2.6.4.2: Water Bodies***

This model (Figure 2-28) uses data from the 1:24,000 scale National Hydrographic Dataset, as well as ponds from two Earth Works Institute Projects: the 2002 EWI Ranch Riparian Vegetation Inventory and the 2006 Galisteo Wetlands Project. This model converts water bodies into raster cells with a value of one (1). All other cells in the output raster get values of 0.

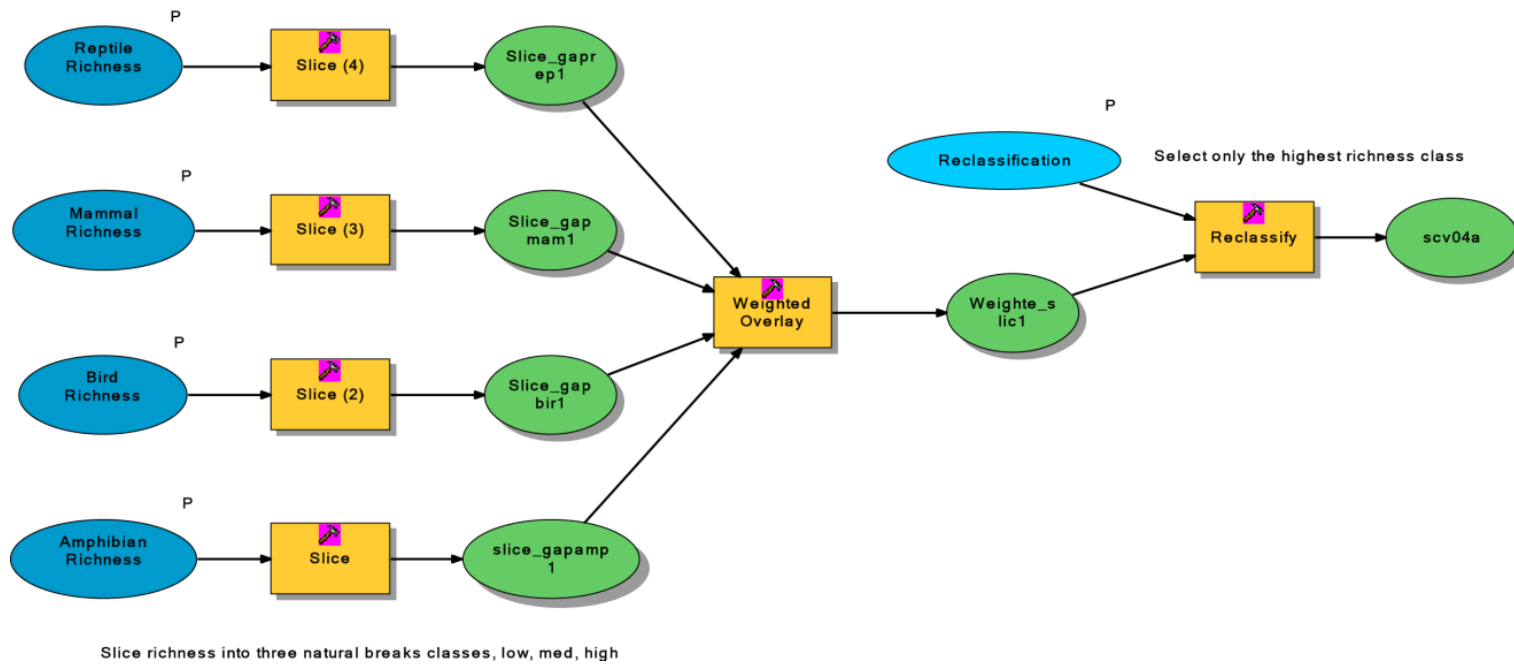

Figure 2-20: Animal Species Diversity Component Model

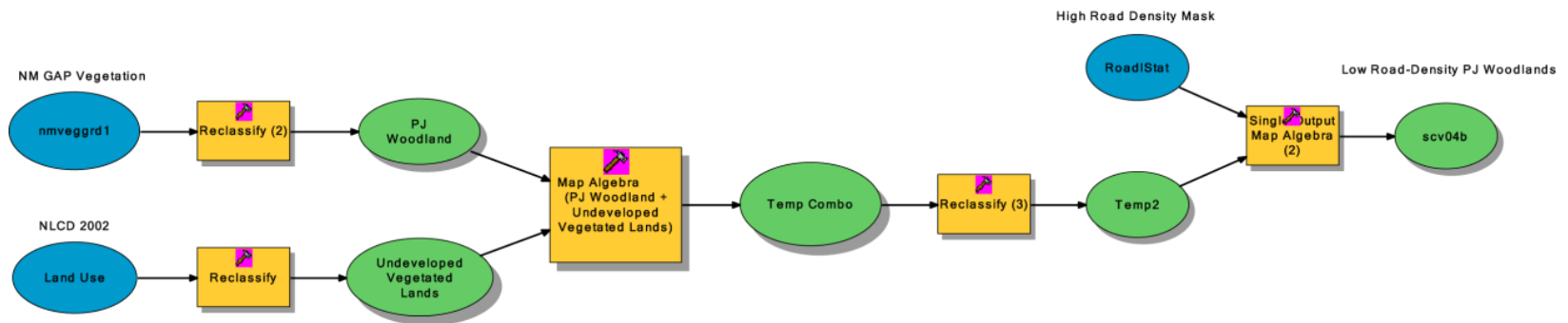

Figure 2-21: Low Road-Density Piñon-Juniper Woodlands Component Model

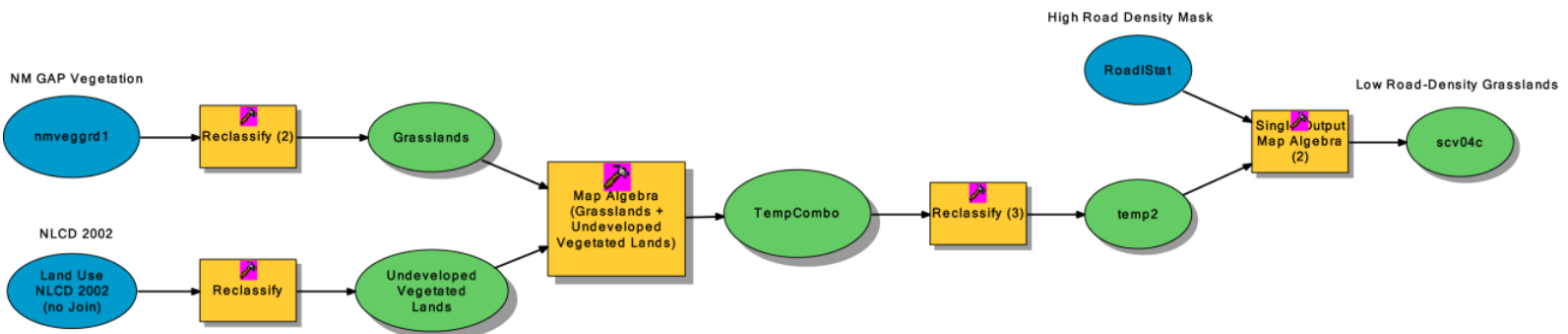

Figure 2-22: Low Road-Density Grasslands Component Model

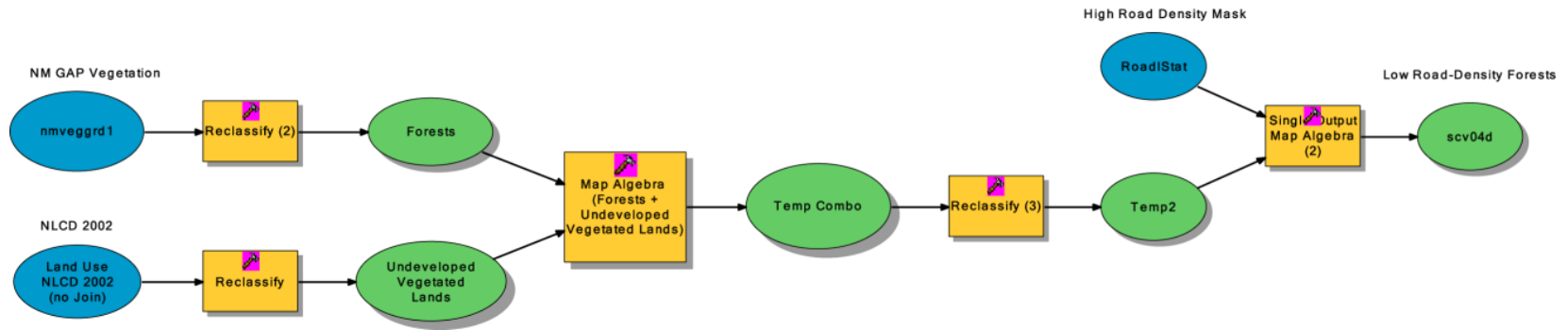

Figure 2-23: Low Road Density Forests Component Model

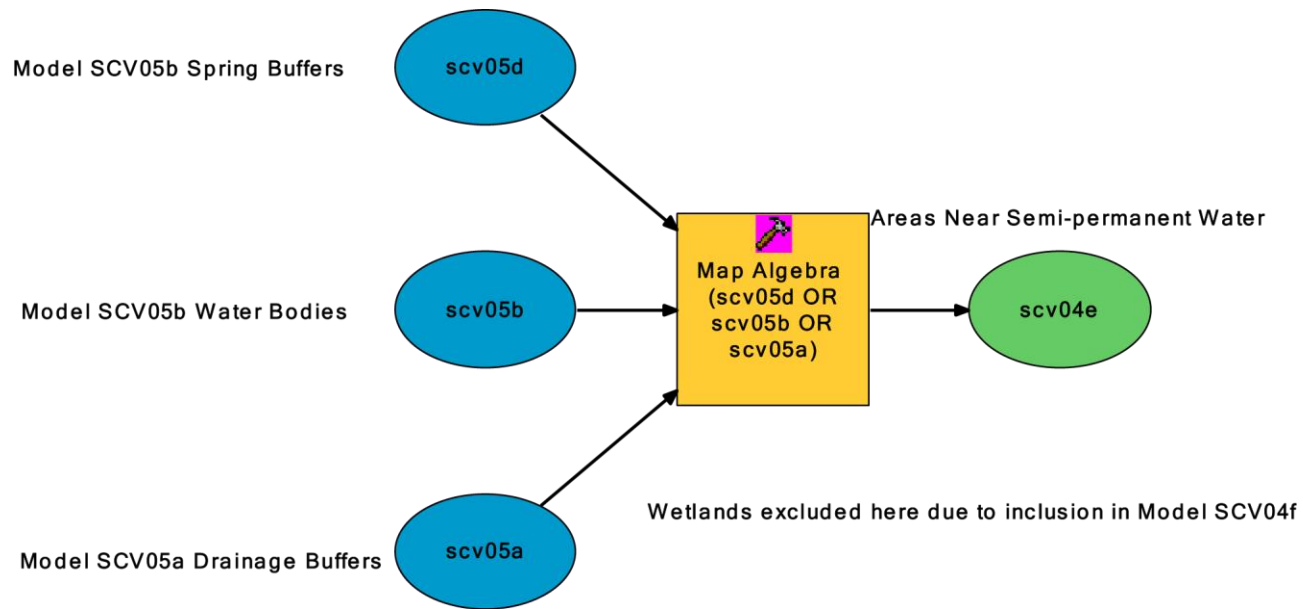

Figure 2-24: Areas near Semi-permanent Water Component Model

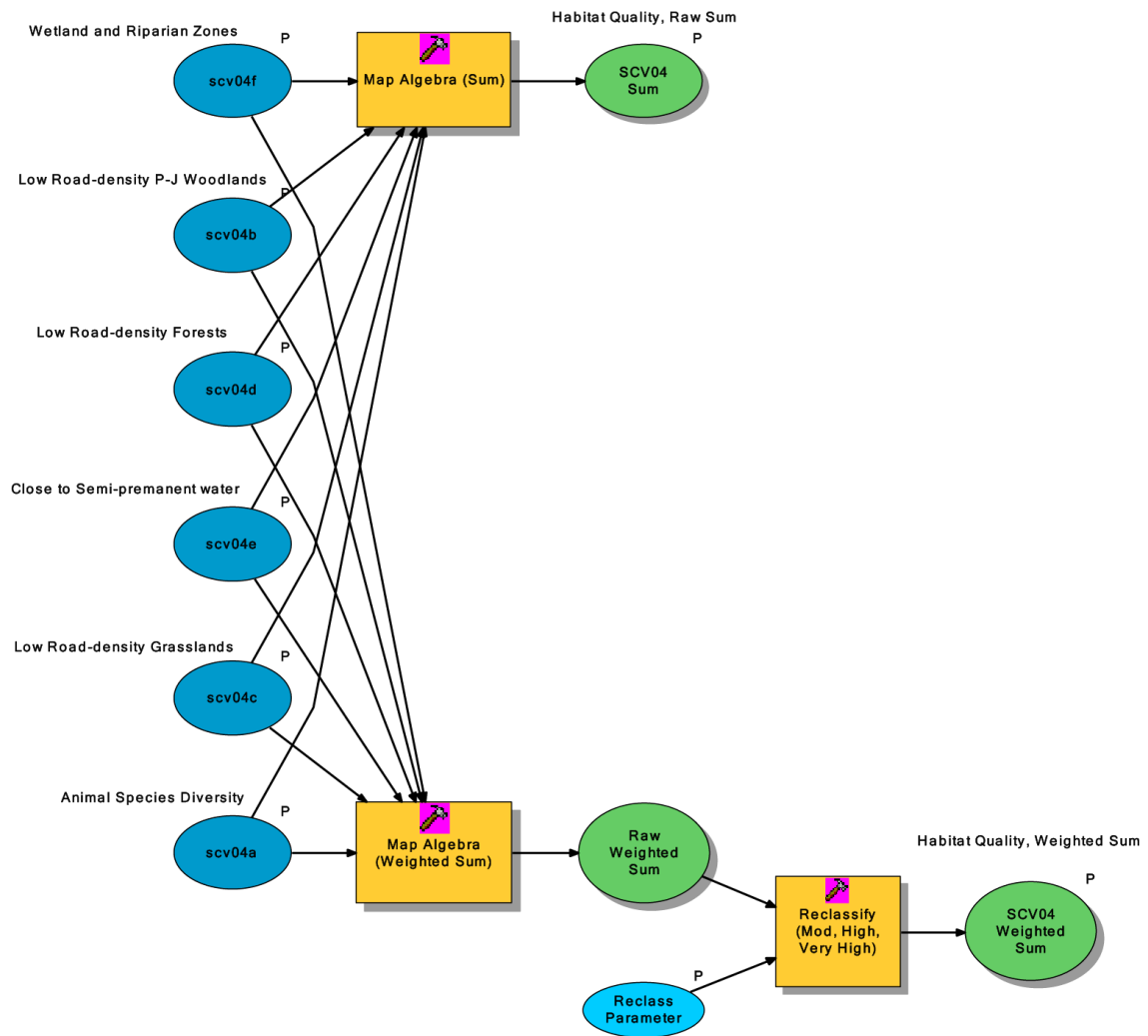

Figure 2-25: Habitat Quality Significant Conservation Value Composite Model

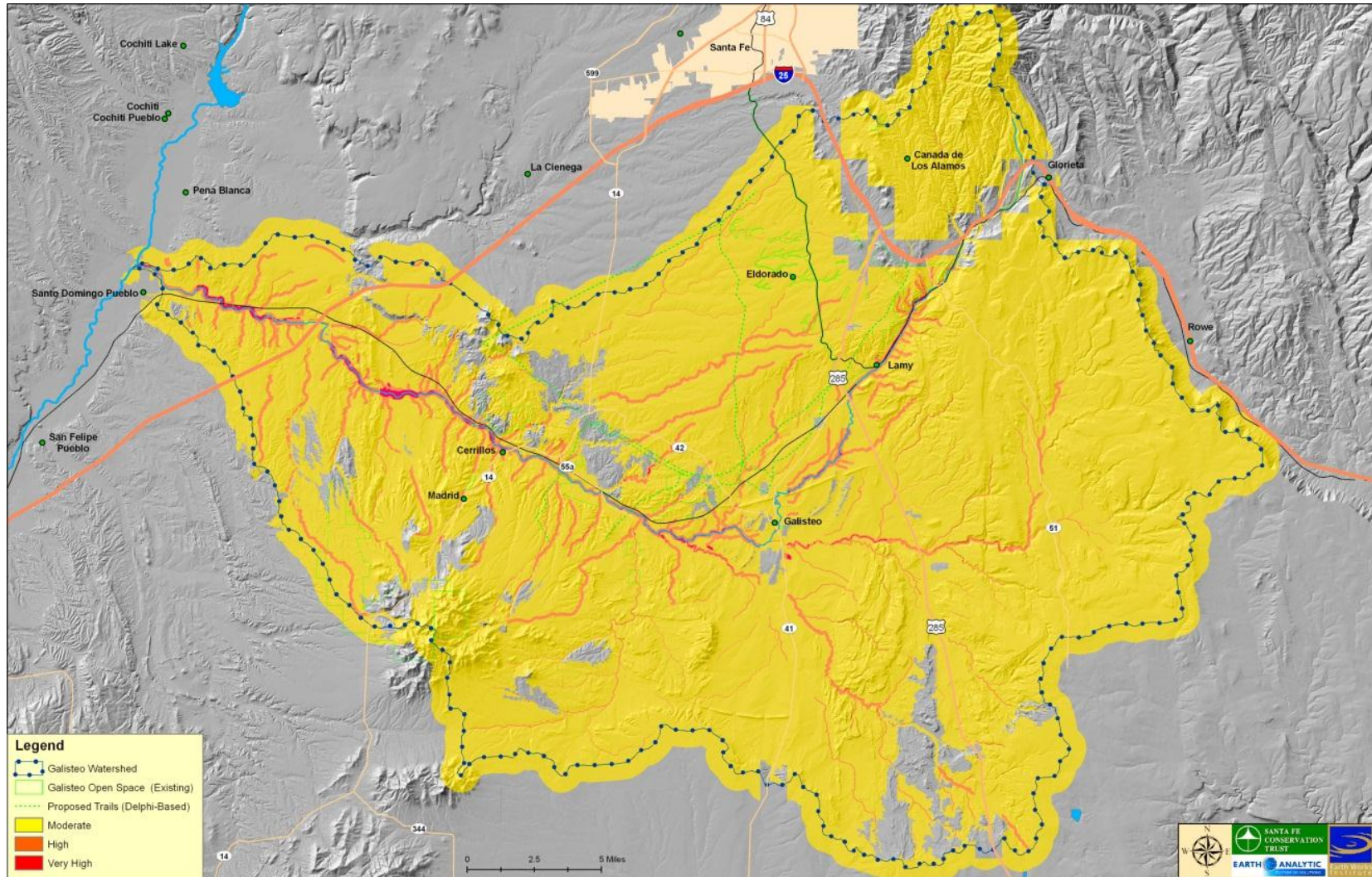

Figure 2-26: Habitat Quality Conservation Value Map

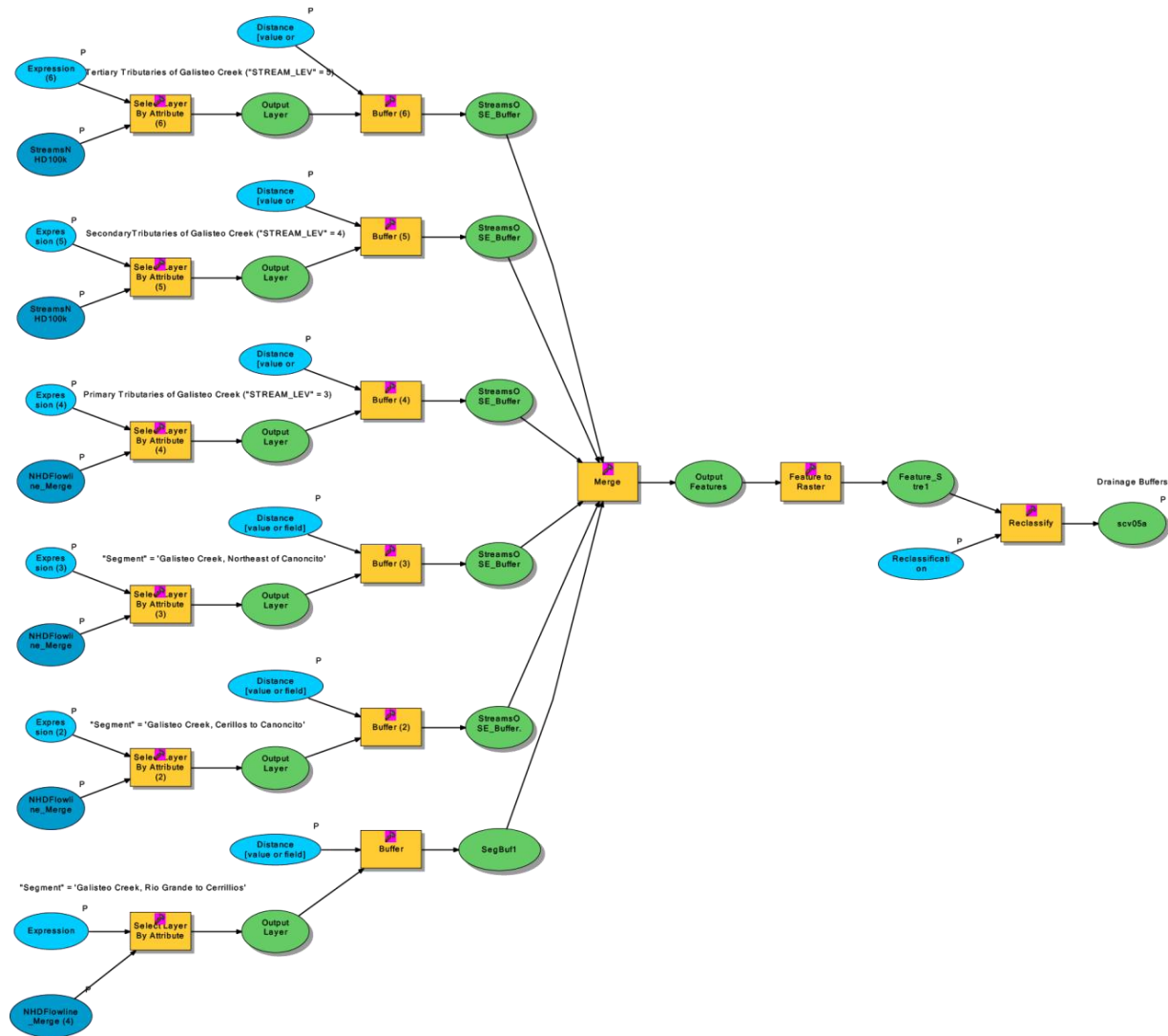

Figure 2-27: Drainage Buffer Component Model



#### ***2.6.4.3: Wetland and Riparian Zones***

In this model (Figure 3-17), the three input datasets are merged into a single layer, converted into a raster. Areas designated as wetlands or riparian areas are assigned a value of one (1) and all other areas get values of zero (0). Importantly, improvements to this model might include ranking different wetland areas, QC and edit of the hand-digitized data, and use of a buffer zone around wetlands to expand the high conservation value envelope for these dynamic features. Three datasets are inputs to this model. Two of the datasets are GPS-based inventories of selected wetlands in the basin: GPS-based (GeoXT, sub-meter) data from 2005-2006 Galisteo Wetland Project and GPS-based (GeoExplorer 3; 1-3 m) data from the 2002 Earth Works Institute Ranch vegetation study. The third dataset consists of probable riparian areas digitized from topos and aerial photos for an infiltration/runoff model created by EWI and Earth Analytic, Inc. in 2004-2005.

#### ***2.6.4.4: Spring Buffers***

Using the nodes from the 1:24,000 NHD dataset, the raster created by this model creates 35 m buffers around springs to cover potential spatial error (Figure 2-30). Cells within the spring buffer areas are assigned scores of one and all other pixels get values of zero.

#### ***2.6.4.5: Aquifer Recharge Zones***

This model rasterizes polygons representing (1) quaternary alluvium (NM Surface Geology, 1:500,000) and (2) soils (SSURGO, including prerelease data for Santa Fe County) classified as excessively or somewhat excessively drained, assigning a value of one (1) to these potential surface recharge deposit areas (Figure 2-31).

#### ***2.6.4.6: Water Significant Conservation Value Composite Model.***

The composite Water Value Model (Figure 2-32 and Figure 2-333) combines the component models in two ways, one based on the sum of input rasters and the other based on a weighted sum process. The non-weighted sum of the five Water Value Component Model rasters results in a layer with values ranging from a minimum of zero (0) to a maximum of five (5). The weighted sum process reclassifies positive output values into three classes of conservation value: moderate, high, very high. Note that for the published release of the GWCI Model, all Habitat Value Component Models were assigned equal weights in the weighted sum analysis.

#### **2.6.7: Significant Conservation Value Wrap-up Model**

The Significant Conservation Value Wrap-up Model (Figure 2-34 and Figure 2-35) combines the component models in three ways, one based on the sum of input rasters, the second based on a weighted sum process, and the third based on the secondary weighting of the weighted sum results from the four composite models. The un-weighted sum of the four primary composite model rasters results in a layer with values ranging from a minimum of zero (0) to a maximum of 15. The weighted sum process reclassifies positive output values into three classes of conservation value: moderate, high, very high. Note that for the published release of the GWCI analysis, all of the primary composite models were assigned equal weights in both the weighted sum and double-weighted sum outputs from the Significant Conservation Wrap-up Model.

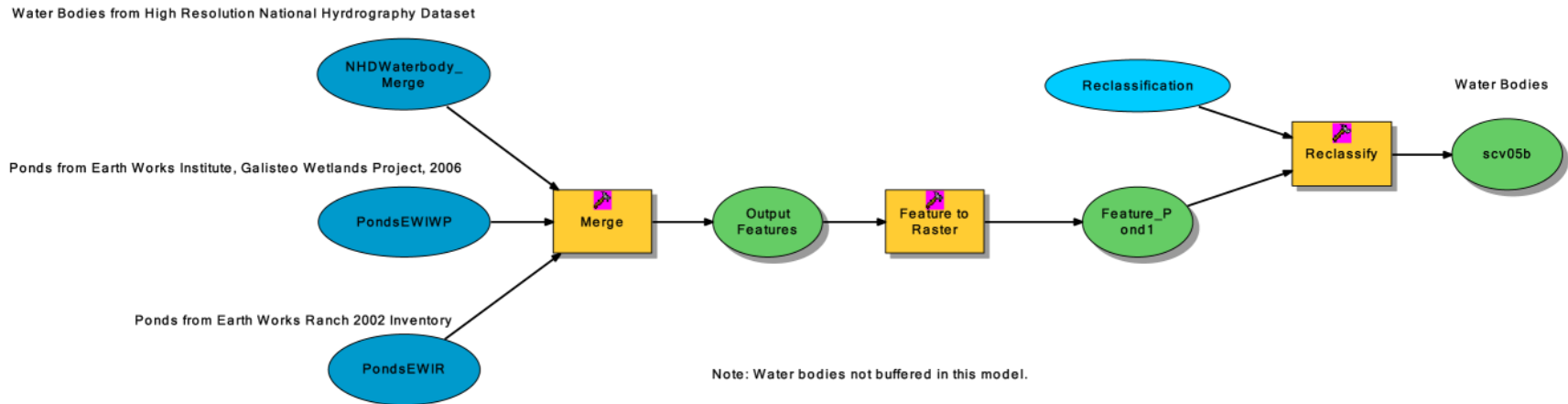

Figure 2-28: Water Body Component Model

Digitized from orthophotos, EWI and Earth Analytic, Inc. in 2004-2005

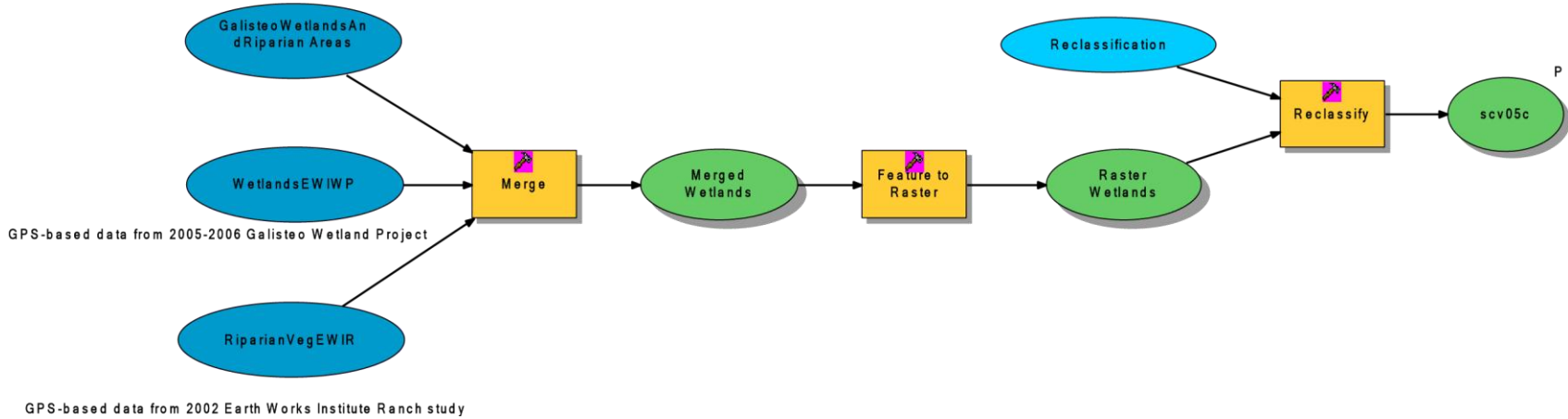

Figure 2-29: Wetland and Riparian Component Model

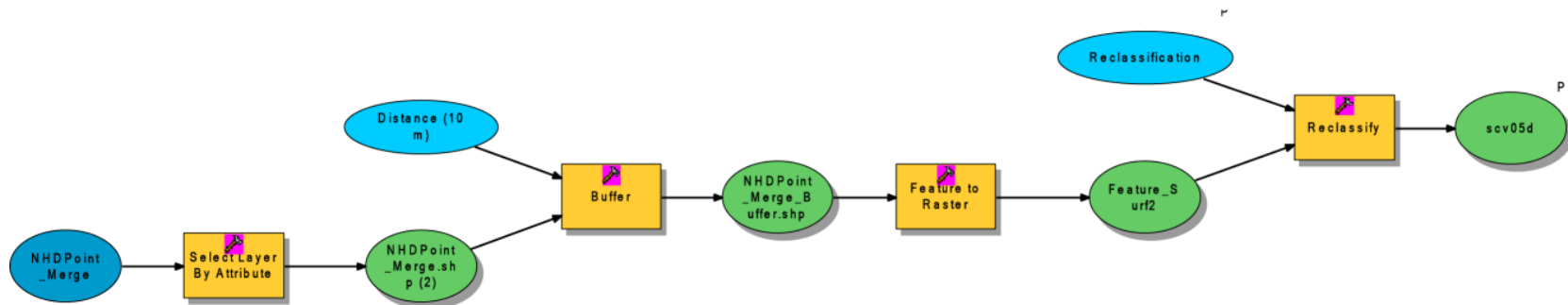

Figure 2-30: Spring Buffer Component Model

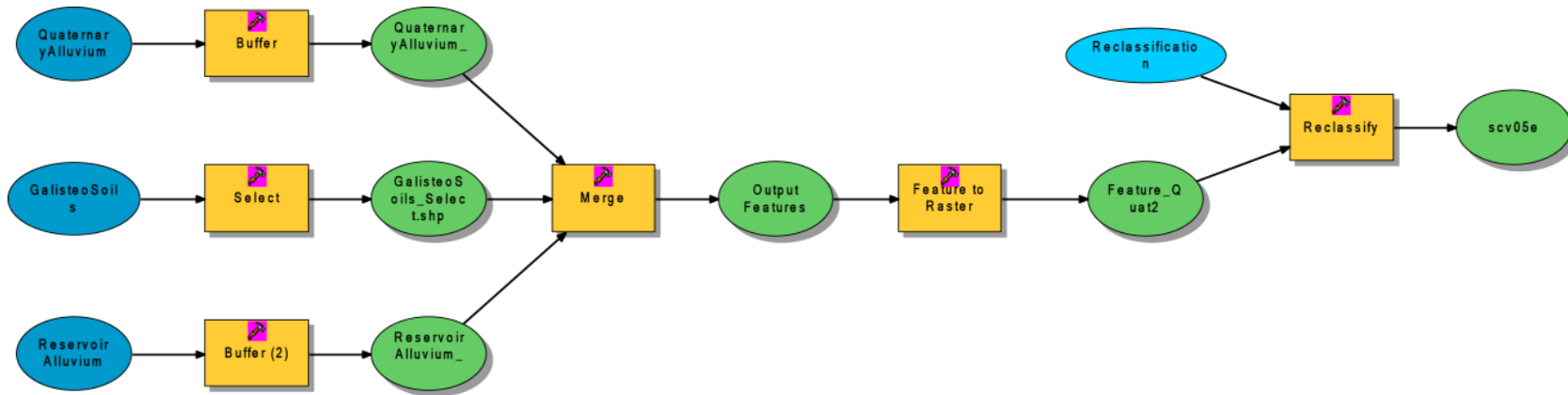

Figure 2-31: Aquifer Recharge Zone Component Model

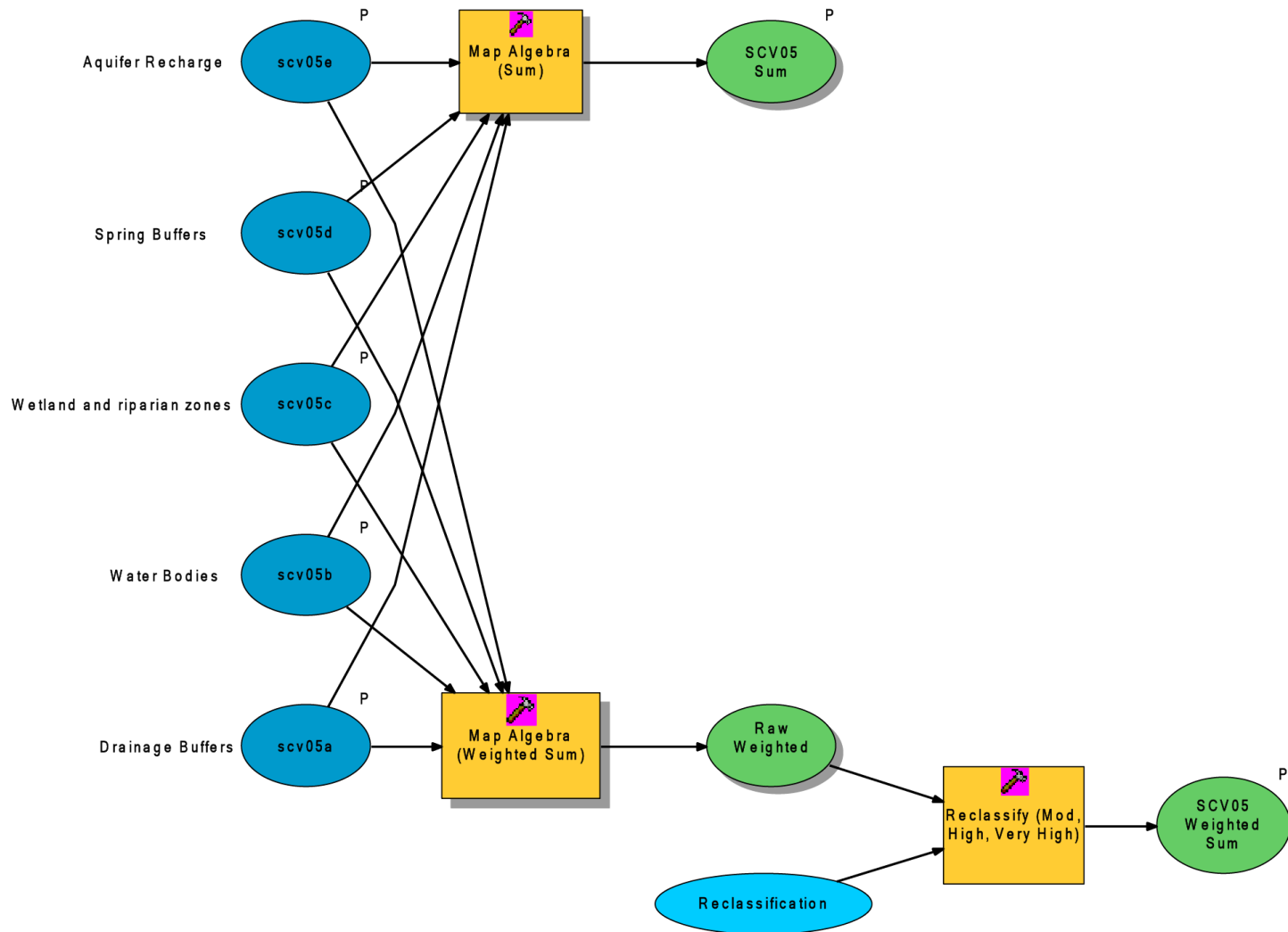

Figure 2-32: Water Resources Significant Conservation Value Composite Model

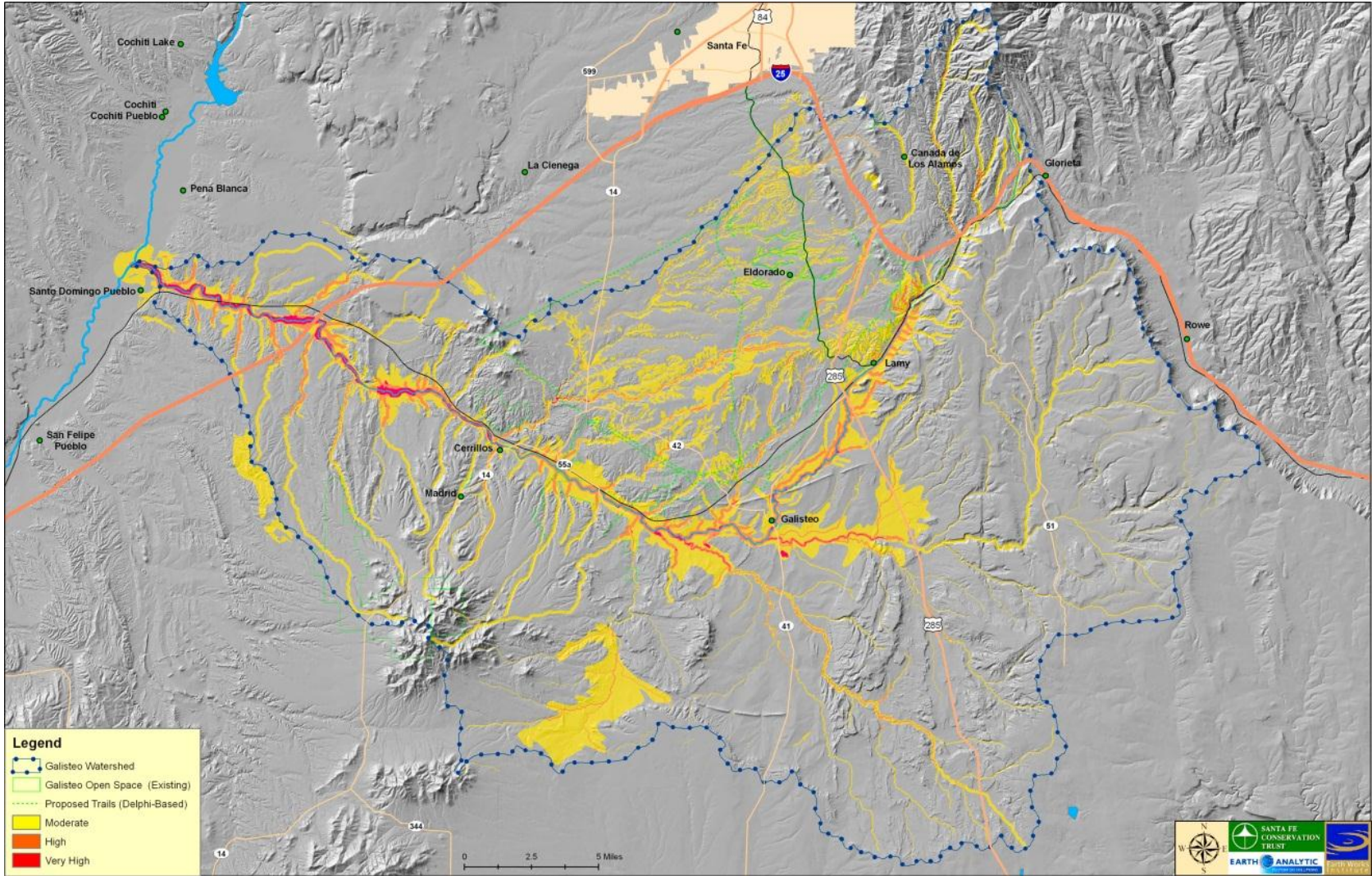

Figure 2-33: Water Resources Conservation Value Map

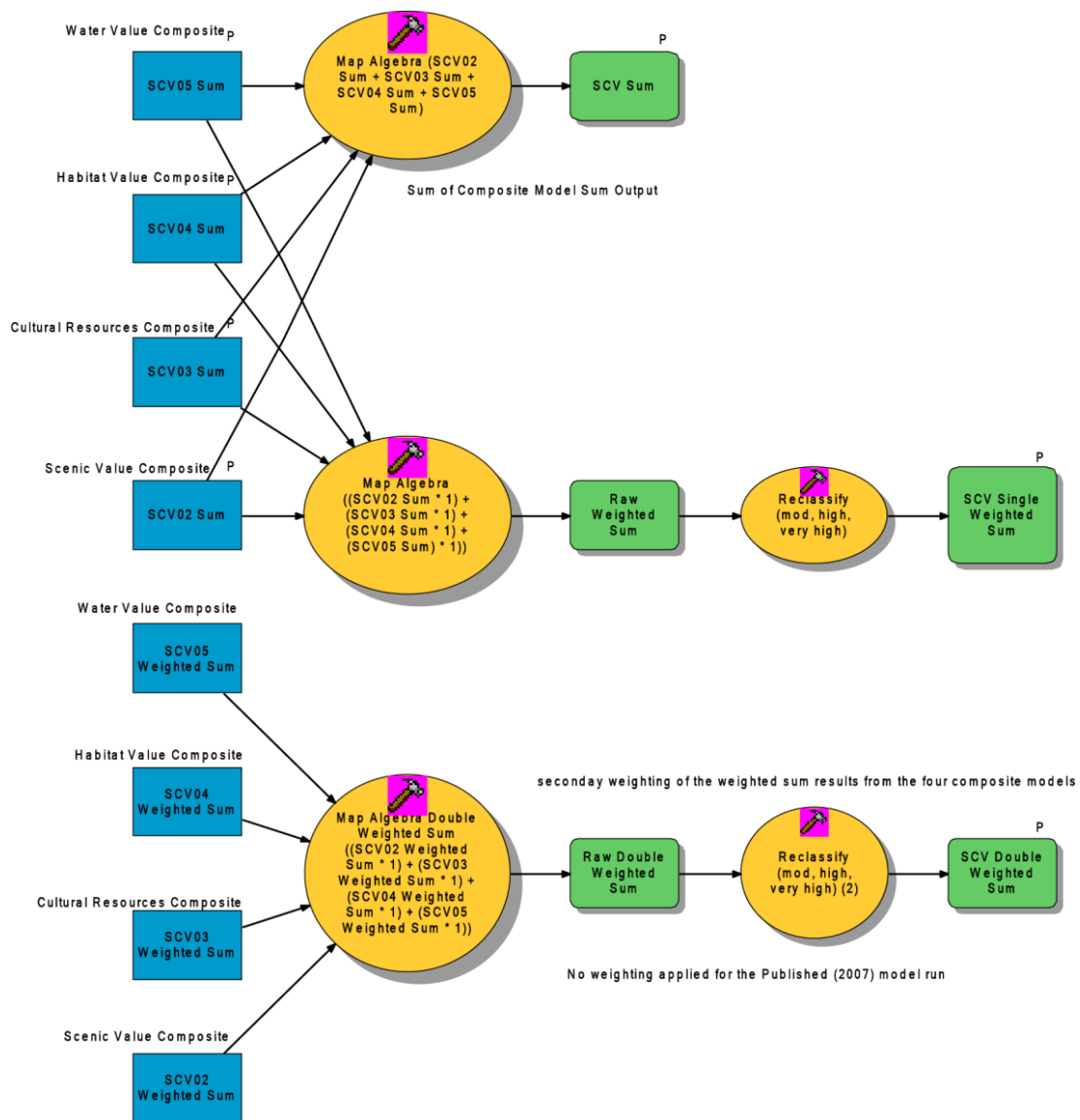

Figure 2-34: GWCI Significant Conservation Value Wrap-Up Model

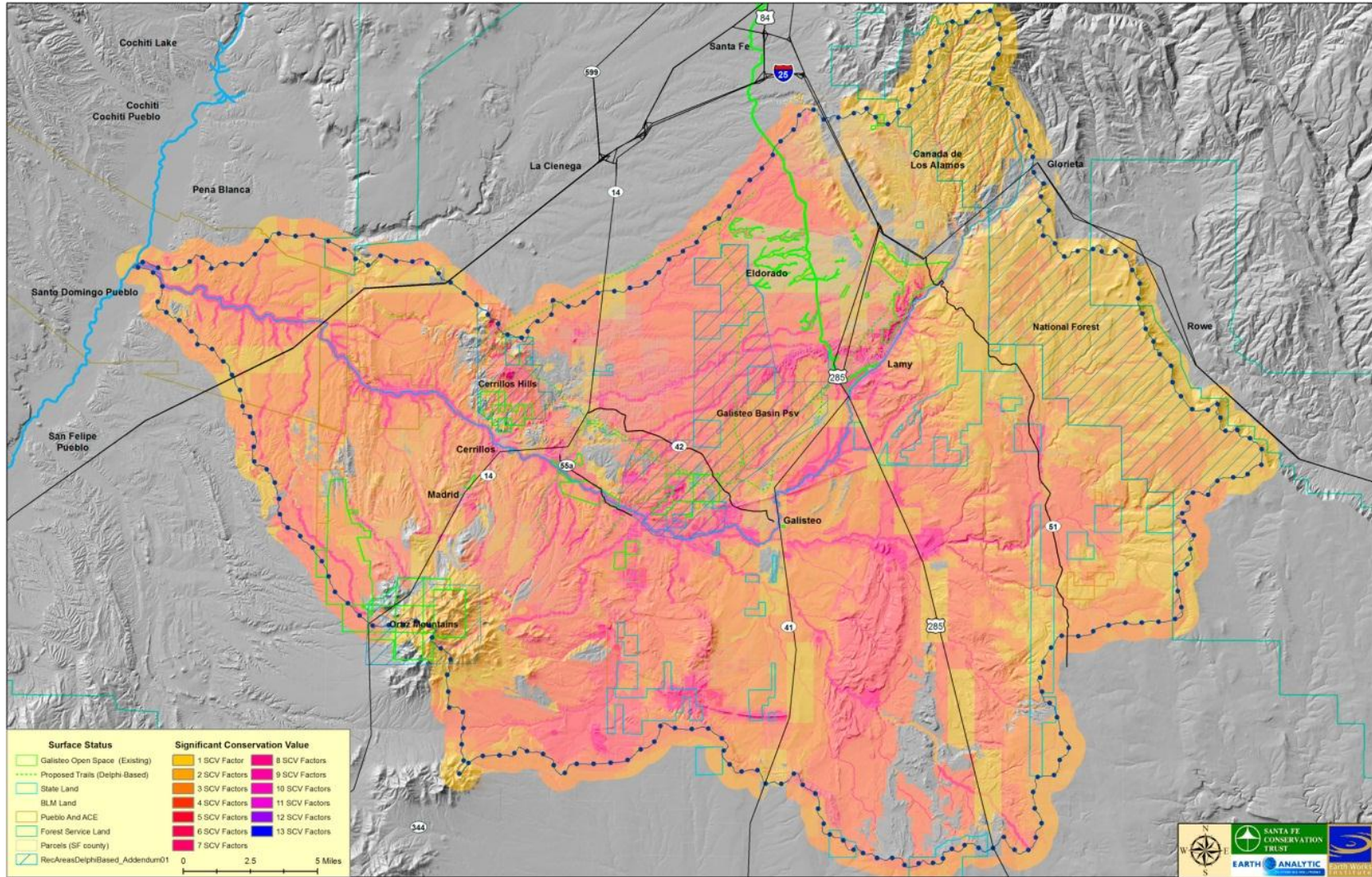

Figure 2-35: GWCI Significant Conservation Value Map (SCV SUM)



## **2.7: Significant Conservation Value Exploration Toolset**

Several additional models were developed to facilitate quantitative assessment of conservation values for specific parcels.

### **2.7.1: Easement Target SCV Exploration Tool**

This geoprocessing tool uses the weighted sum output from the Significant Conservation Value Wrap-Up Model as the basis for identifying parcels intersected by contiguous one-acre-plus zones of maximum conservation value (Very High, 3). More specifically, the model (Figure 2-36) selects cells classified as "Very High" from the weighted sum output from the Wrap-Up model, defines contiguous blocks of these cells, and then further subdivides the output into contiguous blocks of high-scoring cells using the region group and zonal geometry functions. Finally, the model runs zonal statistics on the intermediate output with the parcel dataset, identifying parcels that intersect these contiguous blocks of high-scoring cells. An example of the Target Easement Model results is shown in Figure 2-37.

### **2.7.2: Parcel Zonal Statistics SCV Exploration Tool**

This analysis model calculates zonal statistics for each output from each Composite and Wrap-up Model, using the Santa Fe County Parcel layer (09/2006) as the zone dataset (Figure 2-388). To capture a summary of statistics for each parcel, the unique ID field called PRCSFCO\_ was used in the zonal statistics tool. A separate table is generated for each model output. The statistics summarize model scores for each parcel based on the number of cells of each unique value that fall within a given parcel (Figure 2-39).

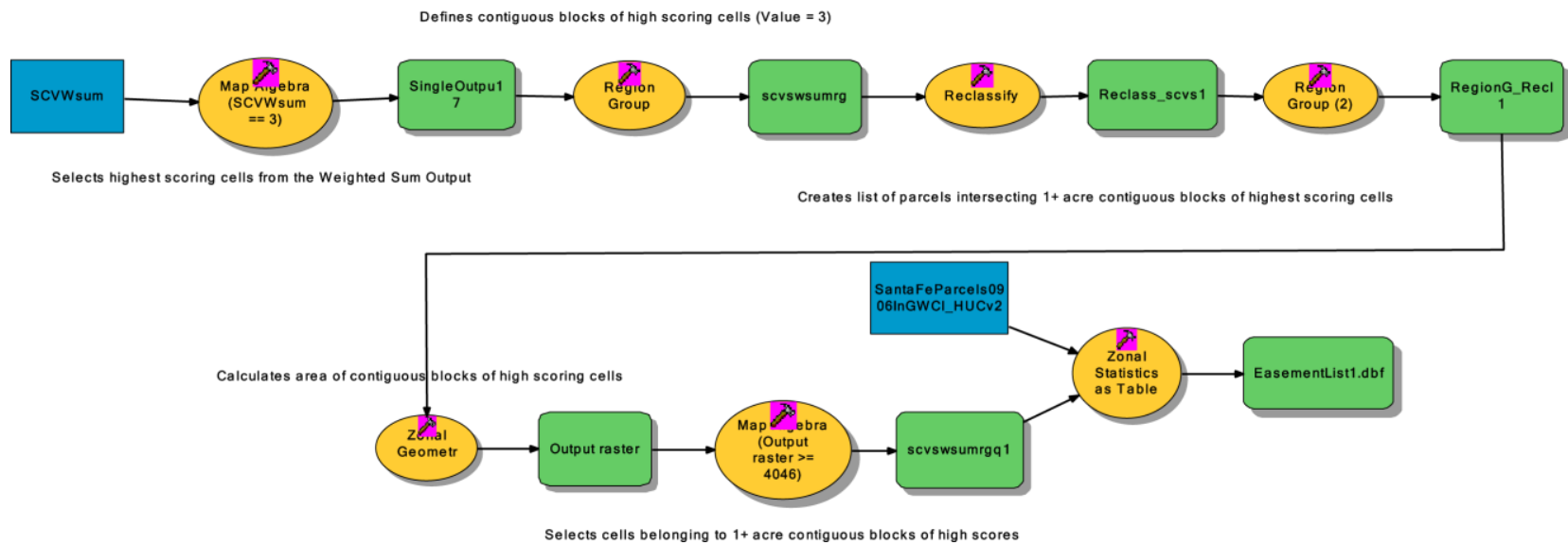

Figure 2-36: Target Easement Model

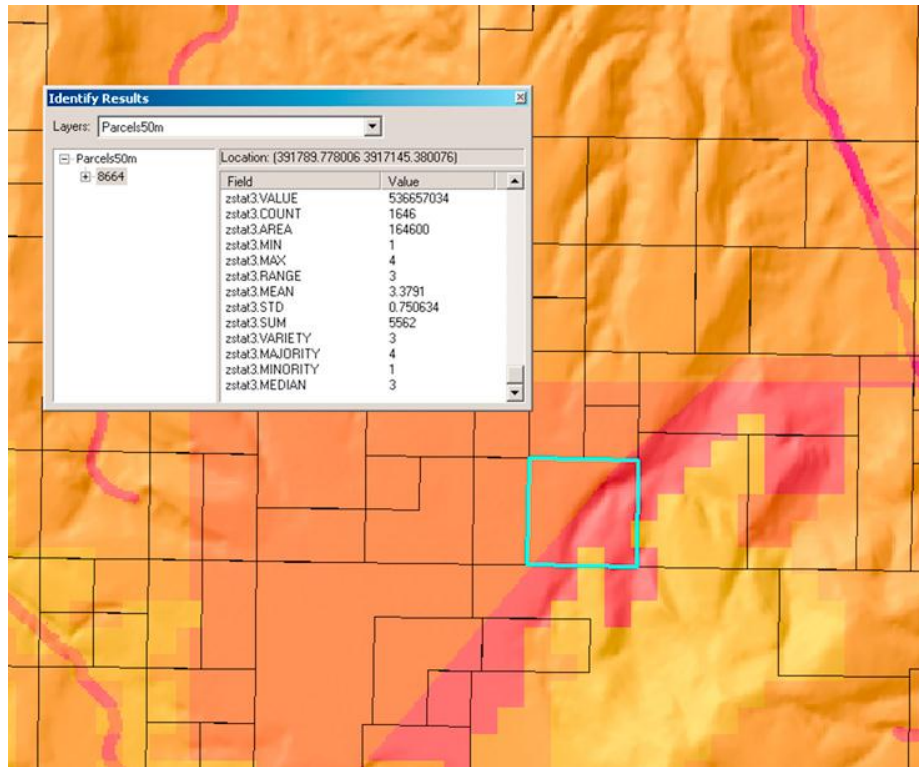

Figure 2-37: Target Easement Tool Results Example

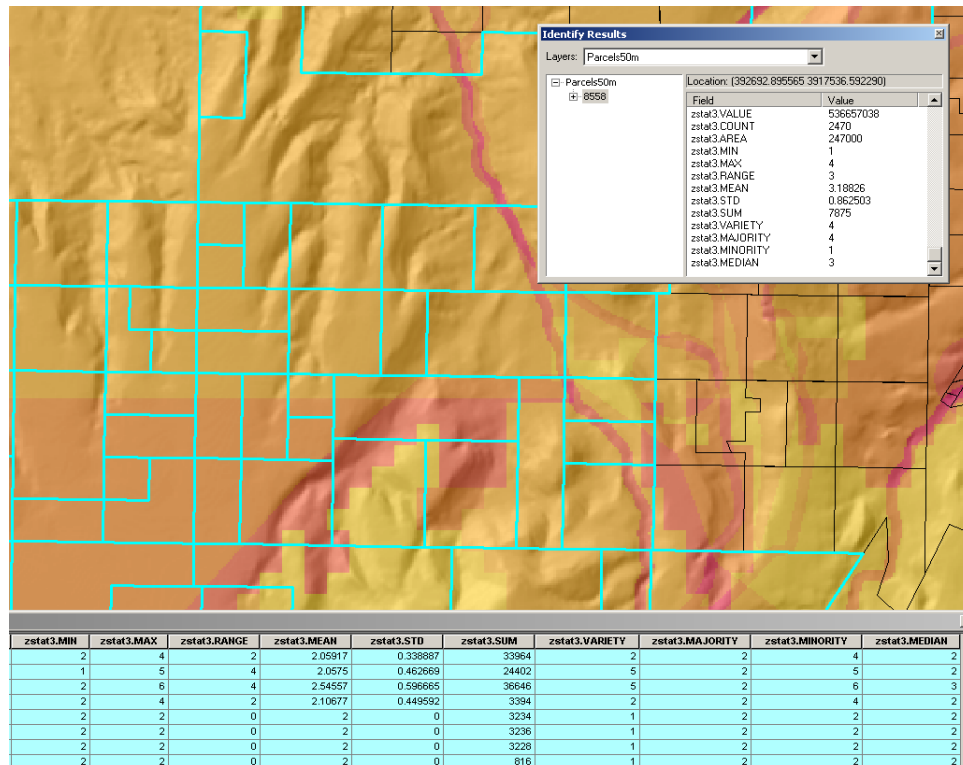

Figure 2-38: Parcel Zonal Statistics SCV Exploration Tool Results

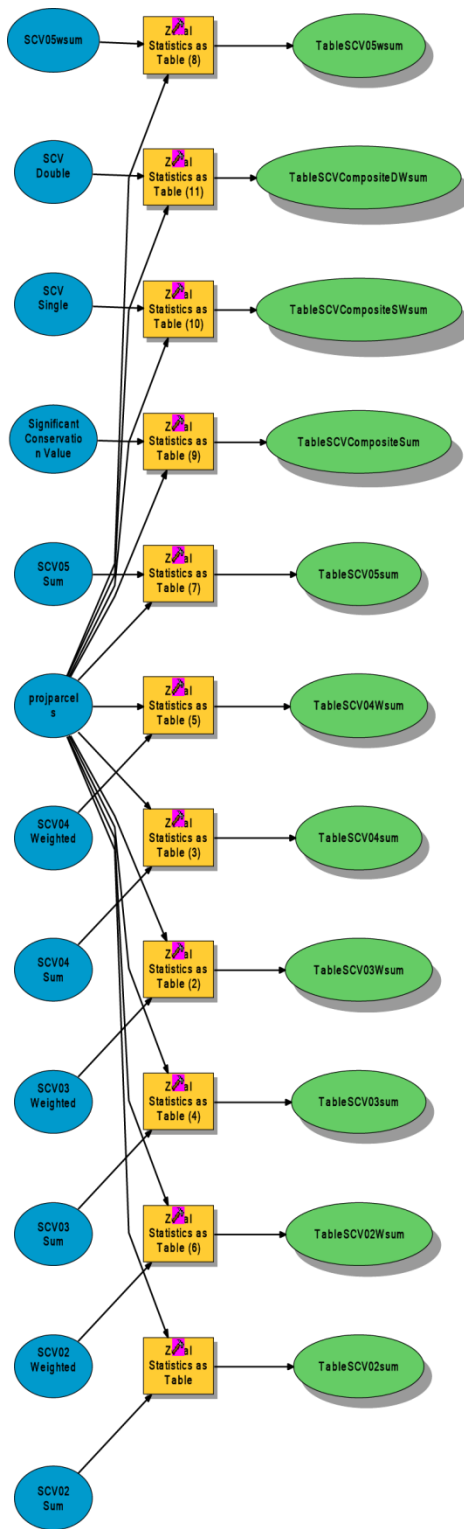

Figure 2-39: Parcel Zonal Statistics SCV Exploration Tool Model

Once the calculation of zonal statistics has been completed, these values can be joined to the digitized site polygons, facilitating the assessment of variability in conservation value across parcels.

### **2.8: GWCI Green Infrastructure Query Examples**

The GWCI framework is designed to allow easy calculations of summary statistics for parcels (or any polygons, for that matter). The following are some examples of the kinds of queries one might run on the model result parcel statistics.

- Query 1: 50,000 private acres in the watershed with highest average composite
  - Solution: To calculate this, one would run the ZS function using the parcels designated as privately owned as the input “zones” and the GWCI overall composite conservation priority surface as the value layer to be summarized. This function would return a suite of statistics summarizing the cell values that fall within each selected polygon. Each privately owned parcel would have a mean score (as well as max, min, majority median, etc...) that could be used in concert with the area (acreage) of that parcel to come up with the 50k private acres with the highest mean score. Importantly, however, one might want to look at other statistics (e.g., majority) or take into account spatial contiguity of high scores. An example of the former would be the identification of all private parcels that have a majority score (the majority of cells in the parcel) of at least 5 or 6 (or whatever the high end of the composite score potential is). To get at contiguity, we could reclassify the composite conservation priority surface so that contiguous areas of cells with scores of x or more (e.g., 6) are assigned a unique code indicating they meet

that criterion. Then, parcels that overlies these contiguous blocks of high scores could be identified. In some cases, it would make more sense to look at acquiring easements in portions of parcels overlying these high-score blocks, rather than acquiring/conserving entire parcels.

- Query 2: total average composite scores of all parcels greater than 1000 acres in size
  - Solution: Select all parcels greater than 1000 acres in size, and then run zonal stats with the composite conservation priority surface as the value raster. This yields average scores for each parcel.
- Query 3: high significant values (in all 6 categories) of all parcels greater than 1000 acres in size
  - Solution: For each Primary model category (e.g., cultural resources), the output conservation value scores range from 0 to 3, where 1 is moderate SCV and 3 is high SCV. These ordinal rankings are generated in each of the Primary model wrap-ups (composite models for each category), taking the full range of scores generated through the straight (or weighted) sum of overlapping scores and slicing that variability into three classes. That said, one could run zonal statistics on parcels greater than 1000 acres for each Primary composite model. Using the resulting scores, one could then select all parcels that scored medium and/or high for all 6 models. This would provide the solution required by the query.
- Query 4: composite map - gross illustration of internal areas of higher significance

- Solution: Use the Primary composite model surfaces and the overall composite model surface as background images with parcels, roads, and other contextual information overlaid on them. The model surfaces can be symbolized to show relative score values, from low to high, with color ramps ranging from light to dark or one color to another (e.g., yellow to red).

## **CHAPTER 3 – THE VERMONT ARCHAEOLOGICAL SENSITIVITY MODEL**

*This chapter is divided into two sections that together provide a general overview of the collaborative effort to design, implement and use the Vermont Archaeological Sensitivity Model, a statewide map of relative archaeological potential for use in cultural resource management assessments and land use planning effort, and a user guide document that describes the data, analysis methods, and results. Section 3.1 is adapted from the original draft of an article published in ArcNews in the Spring 2006 edition, entitled “Modeling Archaeological Sensitivity in Vermont with ArcGIS” (Dorshow 2006). Section 3.2 is an adaptation of the official Vermont Archaeological Sensitivity Model Description and User Guide, distributed by the Vermont SHPO to authorized archaeologists (Dorshow 2007). I authored both of these works.*

### **3.1: Modeling Archaeological Sensitivity in Vermont with ArcGIS**

A key element of archaeological research and cultural resources management is the estimation of the relative potential for buried cultural deposits in specific geographic areas. Reliable estimates of archaeological potential or “sensitivity” are necessary for the implementation of effective archaeological sampling strategies. Quality assessments of relative archaeological potential also are useful planning tools, facilitating the avoidance of potentially significant cultural resources and minimizing the costs of regulatory compliance associated with development.

Over the past several decades, significant improvements in processing capacity and GIS software sophistication have encouraged the development and use of computer-based models of archaeological sensitivity to augment traditional research approaches and field investigations. The Vermont Archaeological Sensitivity Model (VTASM), a GIS-based



framework for simulating archaeological sensitivity statewide, is a recent example of this trend.

The VTASM emerged out of an interest expressed by the Vermont Division of Historic Preservation (DHP) for a statewide GIS map showing relative potential for subsurface prehistoric archaeological deposits. For several years, the DHP has been involved in GIS modeling archaeological sensitivity at the watershed level utilizing environmental criteria specified on a field assessment scoring form used by the DHP and consulting archaeologists. These criteria were adapted from an environmental stratification model developed in 1989 by researchers from the University of Maine at Farmington Archaeology Research Center (UMFARC) for a major pipeline project. Most of the criteria are associated with proximity to water-- features that would have been conducive to prehistoric hunting and gathering subsistence strategies.

The VTASM is an integrated GIS solution for modeling archaeological sensitivity in Vermont based on the well-established DHP environmental criteria. Structured by the new ArcGIS 9.x geoprocessing framework, the VTASM provides a robust suite of tools and a custom data management system designed to allow on-the-fly modification of data inputs and analytical parameters, facilitating the evaluation of different scenarios in a scientifically repeatable manner.

The Vermont Archaeological Sensitivity Model was developed by a team of researchers from the three organizations: Earth Analytic, Inc, the UMFARC, and the University of Vermont Consulting Archaeology Program. Project funding was provided by the Vermont Agency of Transportation and the Vermont Division for Historic Preservation.

ESRI business partner Earth Analytic, Inc. served as the GIS technical lead for the development and implementation of the VTASM. A GIS steering committee comprised of archaeologists from a variety of state and federal agencies and institutions provided oversight and feedback for the project.

The VTASM is implemented with ArcGIS (v.9.2), Spatial Analyst and 3D Analyst software. At the core of the system is a functionally and thematically organized directory structure for GIS data, ArcMap documents, toolboxes, exported maps and documentation. The VTASM user interface is an ArcMap document that points to all required model inputs, and a custom toolbox containing about 20 ArcGIS Models: flowchart-like representations of sequences of GIS data management and analysis processes. The VTASM toolbox is subdivided into two toolsets: one for data Preprocessing and one for statewide analysis. Geoprocessing environment settings are configured at the level of the toolbox, simplifying the process of changing default settings (workspace and scratch space locations, output extent, mask, and cell resolution) for the entire statewide model.

The project database includes statewide wetland and hydrological datasets, including the high resolution (1:5000) Vermont Hydrographic Dataset, as well as SSURGO soils data for most of the state. A notable data limitation is the absence of ten-meter DEMs for the state, although the model does incorporate LiDAR-based eight-meter DEMs for a subset of the project area.

Five major Preprocessing models prepare specific datasets for use in the statewide model: hydrological nodes (confluence and terminus points, collectively referred to as “hydronodes”), LiDAR, floodplain soils, streams, and wetlands. For example, one of

these models draws on outputs from four watershed-specific hydronode Preprocessing models applied to each of the 17 Vermont watersheds (USGS HUC8). Another Preprocessing models converts multiple CAD point datasets into a TIN (triangular irregular network), then converts the output TIN into an eight-meter resolution raster.

The statewide analysis toolset consists of 11 environmental component models (ECMs) that are combined in a composite archaeological sensitivity model. Each ECM yields a statewide 10 m resolution raster with binary cell values. In each raster, cells meeting model criteria are assigned a value of one (1) and remaining cells get values of zero (0).

Six ECM models assign archaeological sensitivity scores to buffer zones associated with specific water-related features: drainages, water bodies, wetlands, stream confluences, stream-water body confluences, heads of draws, and waterfalls. For example, the Drainage Proximity ECM, for example, generates a raster buffer zone of 180 meters around the preprocessed statewide VHD drainages. All cells within 180 meters of streams are assigned a value of one (1) in the output raster. Given the large size of input datasets, the use of raster-based buffering methods (integer-based reclassifications of Euclidean distance surfaces) greatly reduced CPU requirements and time relative to vector-based buffer operations.

The five remaining ECMs assign sensitivity scores to relict lakes, kame terraces, glacial outwash deposits, floodplains and areas of level terrain. One example is the Paleo Lake ECM, which creates a statewide raster in which all areas covered by soils (VCGI/SSURGO) formed in Paleolithic Period lake parent materials are assigned a value of one (1) and all other areas are assigned a value of zero (0).

The final archaeological sensitivity model combines the results of the 12 component models using a weighted sum function. For the preliminary release of the VTASM, all ECMs were assigned equal weights by default. The resulting statewide raster has values ranging from zero to nine, representing the number of overlapping environmental criteria for each cell (Figure 3-1). Ongoing assessments of how well the model predicts known site locations will be used to adjust the model weights in the future.

While the preliminary results of the VTASM analysis are encouraging, indicating that the model has strong predictive value, project stakeholders recognize that computer modeling is not a substitute for first-hand, field-based archaeological assessments in many cases. The project has provided suite of powerful tools for modeling and visualizing reasonable proxies of prehistoric archaeological sensitivity that can be used in concert with traditional archaeological approaches.

Future refinements of the VTASM undoubtedly will come from the integration of higher resolution environmental data (e.g. LiDAR-based elevation) at both statewide and watershed levels. Insights from future research on the assessment of subsurface archaeological potential, as well as site- and watershed-specific analyses guided by the modeling framework will lead to additional enhancements of the VTASM. For more information about this project, contact Wetherbee Dorshow, Earth Analytic, Inc.

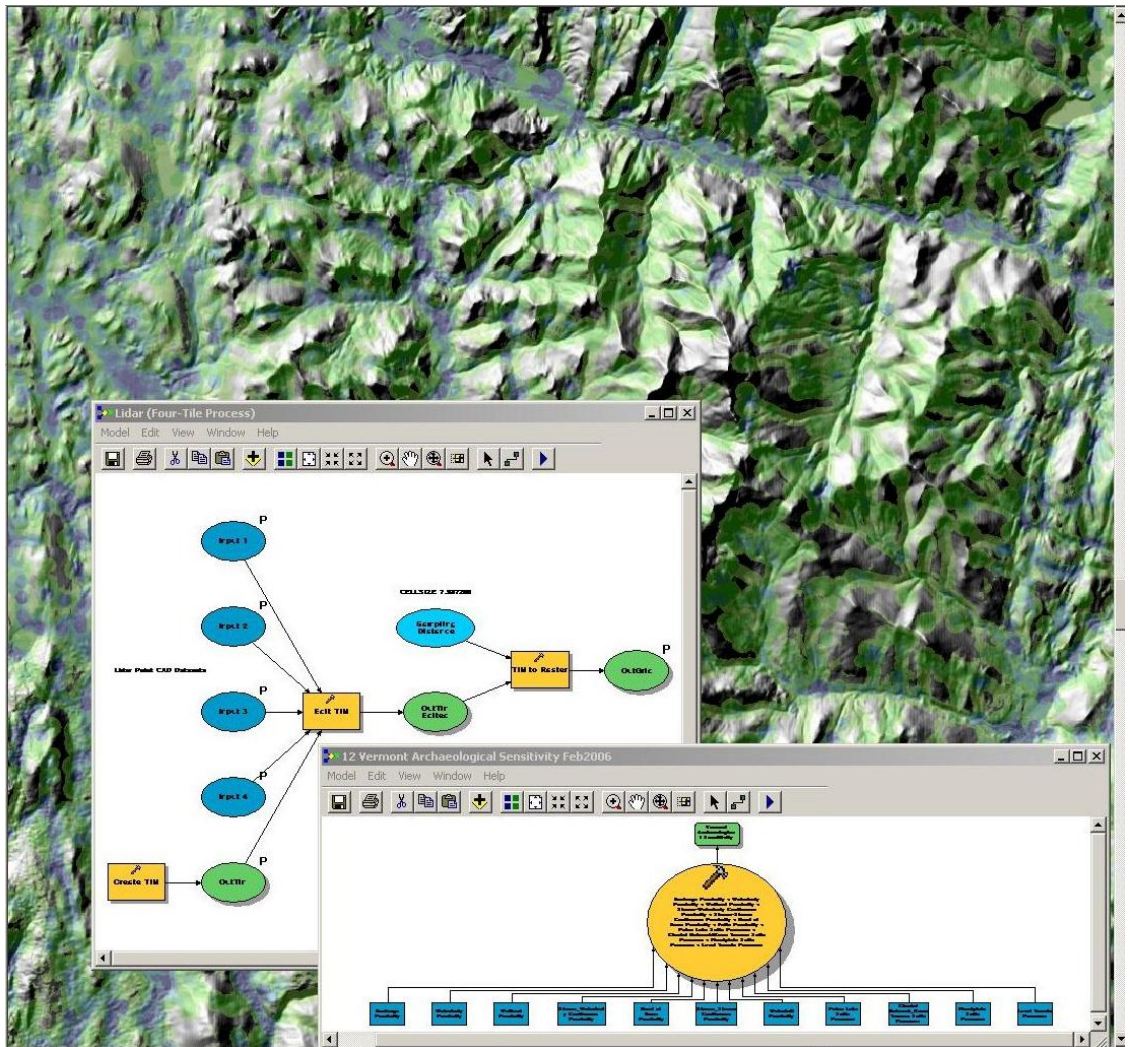

Figure 3-1: Screenshot of Vermont Archaeological Sensitivity Model map document

### **3.2: Vermont Archaeological Sensitivity Model Description and User's Guide**

*This section is adapted from an official handbook distributed by the Vermont Division For Historic Preservation (Dorshow 2007).*

#### **3.2.1: Introduction**

A key element of archaeological research and cultural resources management is the estimation of the relative potential for buried cultural deposits in specific geographic areas. Reliable estimates of archaeological potential or “sensitivity” are necessary for the implementation of effective archaeological sampling strategies. Quality assessments of relative archaeological potential also are useful planning tools, facilitating the avoidance of potentially significant cultural resources and minimizing the costs of regulatory compliance associated with development.

Over the past several decades, significant improvements in processing capacity and GIS software sophistication have encouraged the development and use of computer-based models of archaeological sensitivity to augment traditional research approaches and field investigations. The Vermont Archaeological Sensitivity Model (VTASM), a GIS-based framework for simulating archaeological sensitivity statewide, is a recent example of this trend.

The VTASM emerged out of an interest expressed by the Vermont Division of Historic Preservation (DHP) and the Vermont Agency of Transportation (VTrans) for a statewide GIS map showing relative potential for subsurface prehistoric archaeological deposits. For several years, the DHP has been involved in GIS modeling archaeological sensitivity at the watershed level utilizing environmental criteria specified on a field assessment

scoring form used by the DHP and consulting archaeologists. These criteria were adapted from a paper-based environmental stratification model developed in 1989 by researchers from the University of Maine at Farmington Archaeology Research Center (UMFARC) for a major pipeline project. Most of the criteria highlight proximity to water and landform features that would have been central to prehistoric travel and subsistence strategies.

The Archaeological Sensitivity Model (VTASM) is an integrated GIS solution for modeling archaeological sensitivity in Vermont based on the well-established DHP environmental criteria. Structured by the new ArcGIS geoprocessing framework, the VTASM provides a robust suite of tools and a custom data management system designed to allow on-the-fly modification of data inputs and analytical parameters, facilitating the evaluation of different scenarios in a scientifically repeatable manner.

The Vermont Archaeological Sensitivity Model was developed by a team of researchers from three organizations: Earth Analytic, Inc, the UMFARC, and the University of Vermont Consulting Archaeology Program. Project funding was provided by the Vermont Agency of Transportation. ESRI business partner Earth Analytic, Inc. served as the GIS technical lead for the development and implementation of the VTASM. A GIS steering committee comprised of archaeologists from a variety of state and federal agencies and institutions provided oversight and feedback for the project.

### **3.2.2: General Instructions**

The VTASM was implemented with ArcGIS (v.9.2), Spatial Analyst and 3D Analyst software. At the core of the system is a functionally and thematically organized directory

structure for GIS data, ArcMap documents, toolboxes, exported maps and documentation. The VTASM user interface is an ArcMap document that points to all required model inputs, and a custom toolbox containing about 20 ArcGIS geoprocessing models: flowchart-like representations of sequences of GIS data management and analysis processes. The VTASM toolbox is subdivided into two toolsets: one for data Preprocessing and one for statewide analysis. Geoprocessing environment settings are configured at the level of the toolbox, simplifying the process of changing default settings (workspace and scratch space locations, output extent, mask, and cell resolution) for the entire statewide model.

Figure 3-2 shows the basic directory structure for inputs, outputs and other elements of the VTASM.



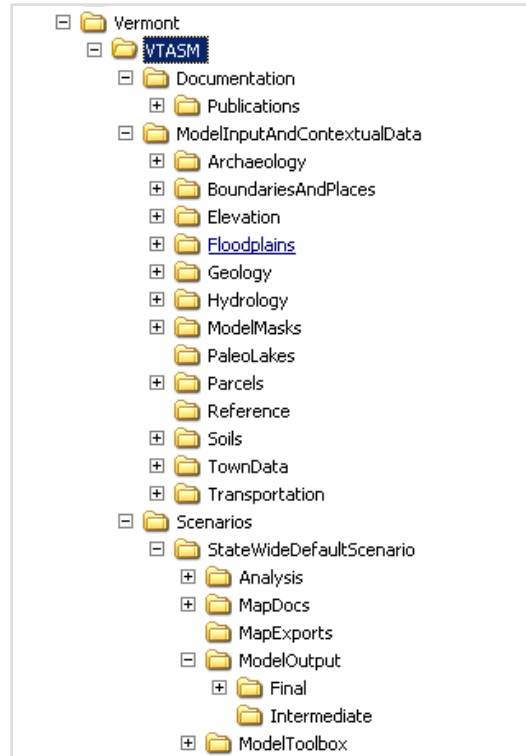

Figure 3-2: VTASM File Directory Structure

The VTASM organizational structure—which includes map documents, toolboxes, models, model inputs and model outputs—is designed to preserve of the default VTASM version while at the same time allowing for the exploration of different versions or scenarios. The VTASM structure takes advantage of the relative path references of ArcGIS 9.x map documents, toolboxes and model outputs, allowing the user to make a copy of the entire default scenario folder. By changing the name of new scenario folder (e.g. StateWideScenario2\_DHP or WinooskiWatershedScenario1) and renaming the map document and model toolbox contained therein, the user can open the map document, reset the environment settings as necessary, and then manipulate the models as desired. Importantly, this scenario-building effort does not require duplication of the model input

data, which is stored in a folder called “ModelInputsAndContextualData” at the same directory level as the root scenario folder.

The project database includes statewide wetland and hydrological datasets, including the high resolution (1:5000) Vermont Hydrographic Dataset, as well as SSURGO soils data for most of the state. A notable data limitation is the absence of ten-meter DEMs for the state, although the model does incorporate LiDAR-based eight-meter DEMs for a subset of the project area.

The body of this document provides a description of each geoprocessing model and some basic instructions for the use of the default version of the VTASM, encapsulated in the “Scenarios\StateWideDefaultScenario” folder. The instructions assume a general familiarity with ArcGIS, Spatial Analyst and ModelBuilder at the 9x level.

### **3.2.3: Data Preparation Geoprocessing Tools**

Five preprocessing models (data preparation geoprocessing tools) prepare specific datasets for use in the statewide models: hydronodes, lidar, floodplain soils, streams and wetlands. These tools are stored in the “Preprocessing” toolset within the VTASM toolbox. Once all of the pre-processing models have been run successfully, all necessary inputs are available for the twelve statewide models. The data preparation tools should only be run when input datasets are updated.

The datasets currently contained in the statewide “ModelInput” folder are derived from the most recently released (as of May 2005) versions of the Vermont Hydrographic dataset (VHD), the Vermont Wetlands Inventory, and a variety of other USGS and State GIS data sources. Metadata for each layer is included in the metadata xml document

associated with each input dataset. Although Orleans County SSURGO soils data are now available, the absence of attribute information for kame terrace/glacial outwash and paleo-lake precluded their use in the February 2006 model run.

To examine or rerun the preprocessing models, open the following map document:

....Scenarios\StateWideDefaultScenario\MapDocs\VTASM\_StatewideApril072006.mxd.

The Vermont Archaeological Sensitivity toolbox shown below should appear when this map is opened. If it does not, make sure the toolbox is turned on (visible) in the map document, then right-click on the ArcToolbox header, select “Add Toolbox”, and browse to the ....Scenarios\StateWideDefaultScenario\ModelToolbox folder and add the Vermont Archaeological Sensitivity Model toolbox. The Preprocessing models are in the toolset with the corresponding name (Figure 3-3).

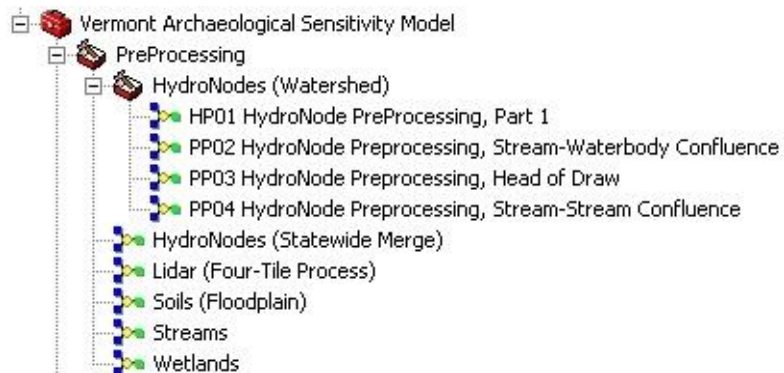

Figure 3-3: VTASM Preprocessing Tools

### ***3.2.3.1: Soil Data Preparation***

The Soil data preprocessing model extracts soils formed in probable floodplain deposits from the Vermont SSURGO soils dataset (Figure 3-4). The model joins a list of floodplain soil MUSYM codes with the soil polygons, and then extracts the successfully joined records into a new dataset.

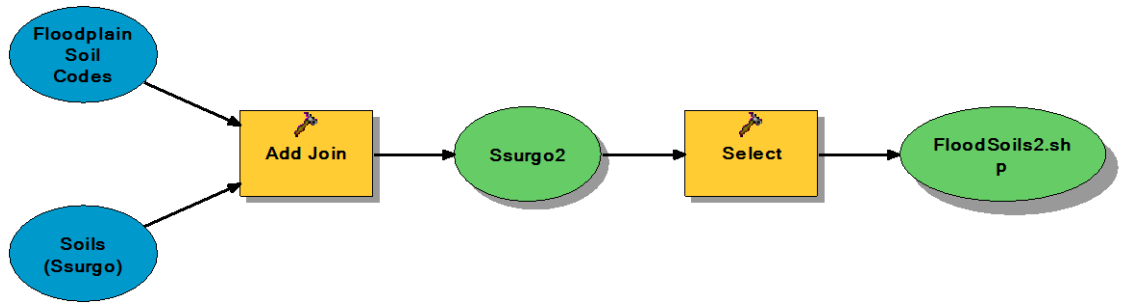

Figure 3-4: Soil Data Preparation Model

As shown in Figure 3-5, SSURGO data was not available for portions of northeastern Vermont at the time of the February 2006 model run. As such, these areas were excluded from soil related statewide models.



Figure 3-5: SSURGO Data Availability Status Map

### 3.2.3.2: Stream Centerline (Flowline) Data Preparation

The Flowline preprocessing model compiles a statewide stream centerline dataset that excludes artificial connectors (stream segments overlain by water bodies included in the network) using a simple selection query. This step prevents the double counting of stream centerlines within defined water body polygons. The input to this model is a stream centerlines within defined water body polygons. The input to this model is a personal geodatabase feature class containing an appended composite of 17 polyline datasets called route.drain obtained from each of the VHD watershed coverages (Figure 3-6).

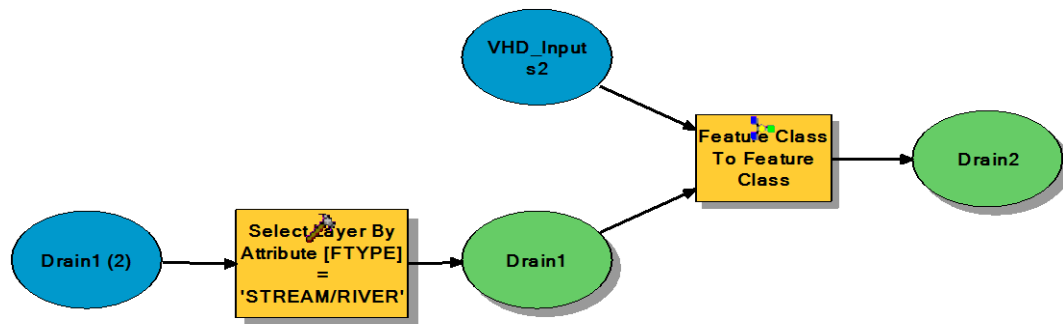

Figure 3-6: Flowline Data Preparation Model

### 3.2.3.3: Wetlands Data Preparation

The Wetland preprocessing model yields a statewide wetlands dataset from which VHD water bodies have been erased (Figure 3-7). This procedure prevents the double counting of overlapping water body and wetland polygons. The order of precedence in the aforementioned erase procedure is based on the higher spatial resolution and relative accuracy of the VHD water body datasets.

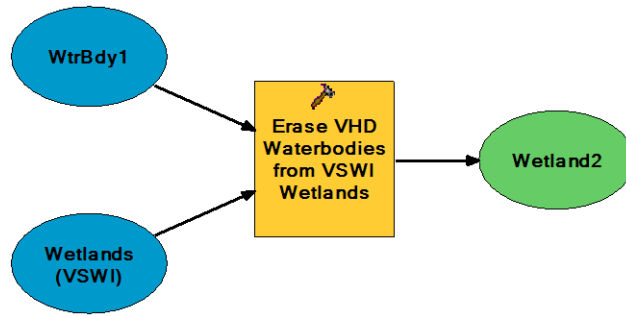

Figure 3-7: Wetlands Data Preparation Model

### 3.2.3.4: LiDAR Data Preparation

The LiDAR preprocessing model converts four point feature CAD datasets into a TIN (triangular irregular network), and then converts the output TIN into an eight-meter resolution raster (Figure 3-8). This tool can be used in multiple iterations to produce output tiles.

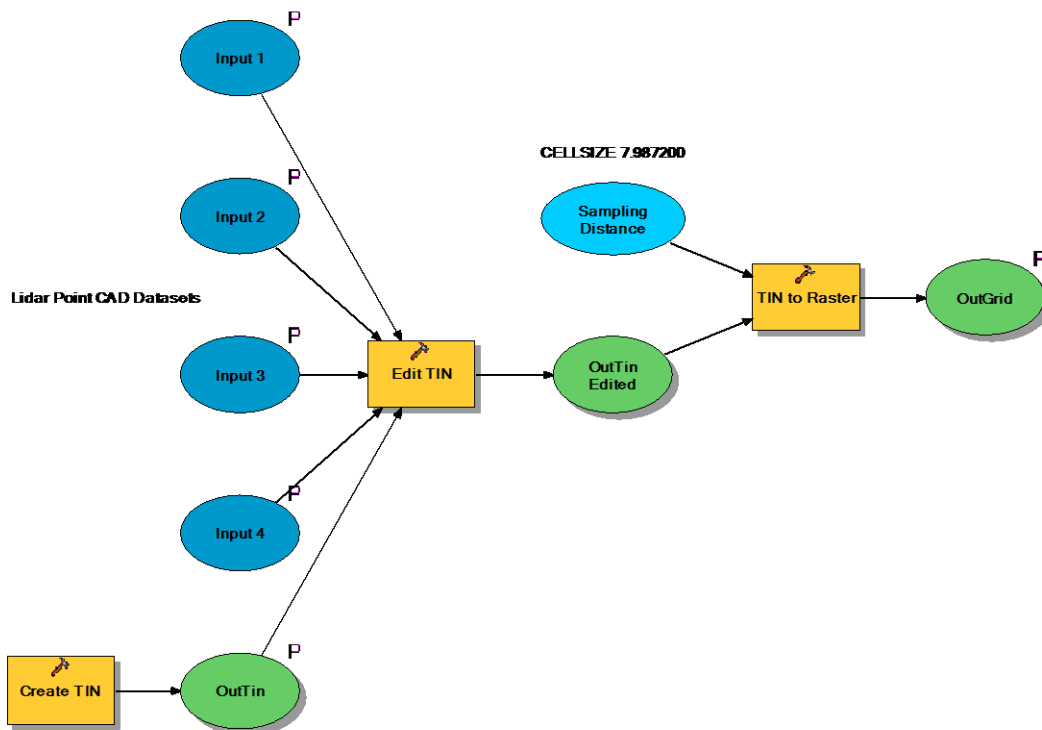

Figure 3-8: LiDAR Data Preparation Model

For the February 2006 analysis, we generated a total of five LiDAR-based tiles for inclusion in the level terrain model. In late March of 2006, we completed the processing of the entire Chittenden County MPO area, shown in the map below.

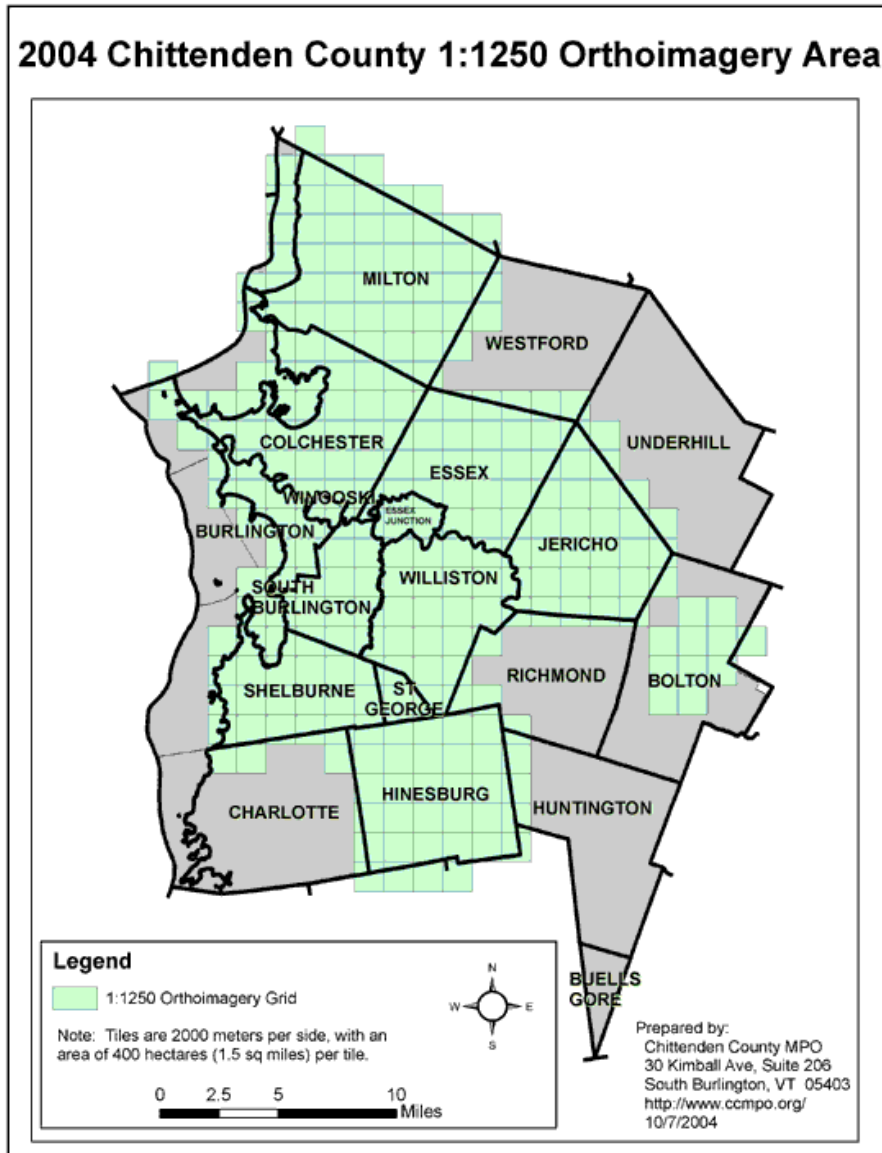

Figure 3-9: LiDAR Data Coverage

### 3.3.5: Hydronode Data Preparation

Originally, the VTASM was designed to be run on each of seventeen Vermont watersheds defined in the USGS eight-digit Hydrologic Unit Code schema. Several of the data preparation tools used in the first iteration of the VTASM were used to prepare data for inclusion in the current model version. These consist of four hydrological node processing models that yield three specific “hydronode” feature classes: stream-stream confluences, stream-water body confluences and heads of draws. The following sections describe each of the watershed-specific models in the HydroNode\_WatershedName Toolset in the Pre-Processing Toolbox. Outputs from the four watershed-specific hydronode models for each of the 17 Vermont watersheds are merged into a single hydronode dataset in the Statewide Hydronode Model. Artificial stream confluences covered by water bodies were manually designated in a secondary output from this model called Hydronodes2.

#### ***3.2.3.5: Hydronode Preprocessing, Part 1***

This model runs a series of functions that prepares the (VHD) node dataset for attribution as stream-stream confluences, stream-water body confluences or heads of draws (Figure 3-10).

#### ***3.2.3.4: Hydronode Preprocessing, Part 2***

This model populates the attributes of the node table field called FTYPE with the value “Stream/Water body (Figure 3-11).

#### ***3.2.3.5: Hydronode Preprocessing, Part 3***

This model populates the attributes of the node table field called FTYPE with the value “Head of Draw” (Figure 3-12).



#### ***3.2.3.6: Hydronode Processing, Part 4***

This model populates the attributes of the node table field called FTYPE with the value “Stream/Stream Confluence“(Figure 3-13).

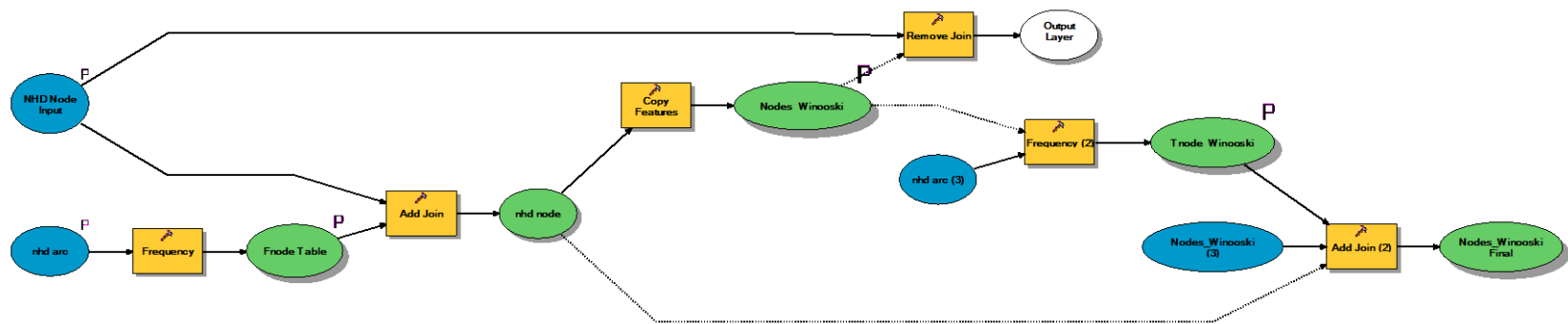

Figure 3-10: Hydronode Preprocessing Model (Part 1)

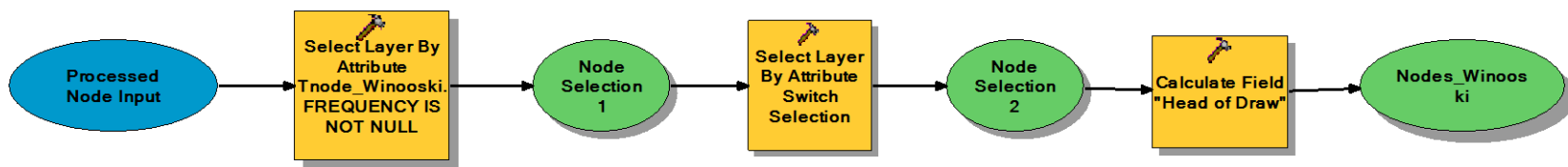

Figure 3-11: Hydronode Preprocessing Model (Part 2)

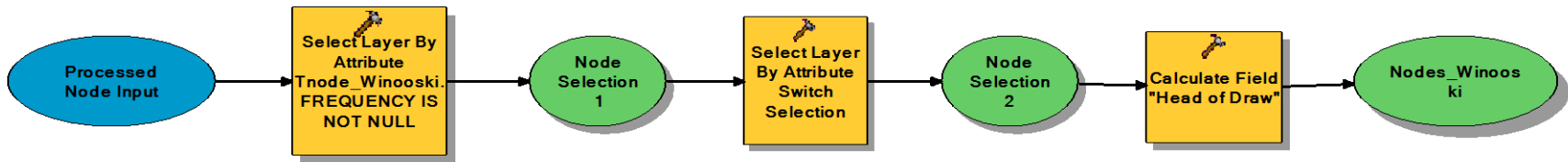

Figure 3-12: Hydronode Preprocessing Model (Part 3)

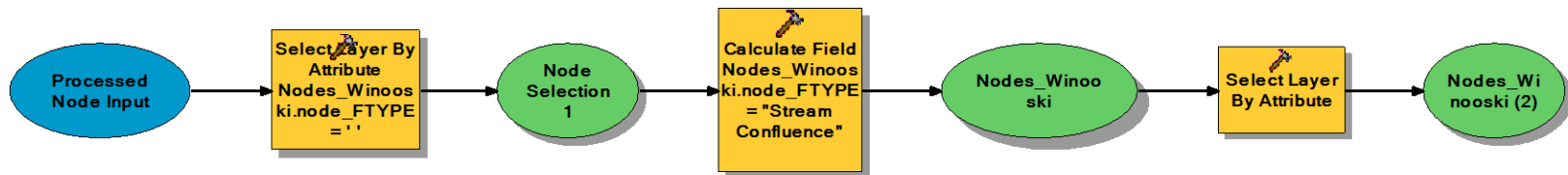

Figure 3-13: Hydronode Preprocessing Model (Part 4)

### 3.2.4: Statewide Default Scenario Toolbox and Analysis Environment Settings

Figure 3-14 shows the Statewide Default Scenario Toolbox. All of the 12 sensitivity models are located in the Archaeological Sensitivity Toolset within this toolbox, which is linked to the ArcMap document located in the following folder:

Scenarios\StateWideDefaultScenario\MapDocs\VTASM\_StatewideApril072006.mxd .

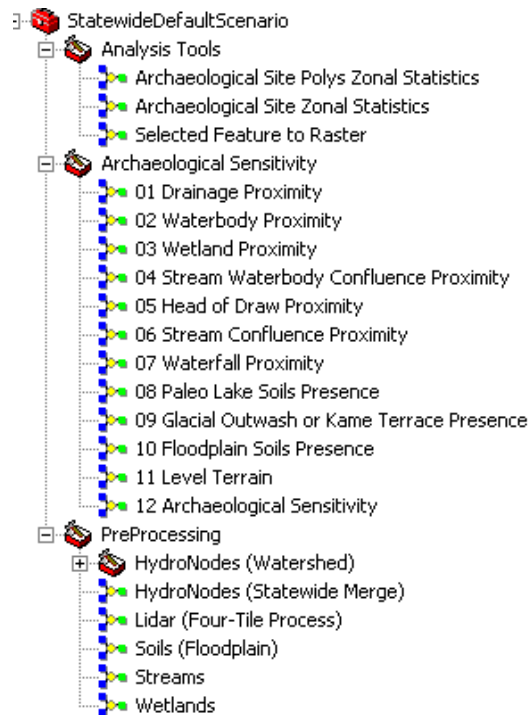

Figure 3-14: VTASM Toolbox

Make sure that the proper toolbox opens with the map and check that the geoprocessing environment settings match the following.

- General Settings
  - Current Workspace: the ModelInputAndContextualData subfolder in the statewide directory
  - Scratch Space: the ModelOutput\Intermediate subfolder in the statewide directory
  - Analysis Extent: Same as the raster “VermontBound”

- Raster Analysis Settings:
  - Cell Size: 10 m
  - Mask: Same as the raster “VermontBound”

One can use the environment settings xml file located in the following folder to set the environment as well: Scenarios\StateWideDefaultScenario\ModelToolbox. The statewide models are described in the following section.

### **3.2.5: Statewide Toolset Geoprocessing Model Descriptions**

#### ***3.2.5.1: Drainage Proximity***

This model creates a raster buffer zone of 180 meters around the preprocessed VHD stream statewide dataset (Figure 3-15). All cells within 180 meters of streams are assigned a value of one (1) in the output raster.

#### ***3.2.5.2: Water Body Proximity***

This geoprocessing model creates a raster buffer zone of 180 meters around the preprocessed VHD statewide water body dataset (Figure 3-16). All cells within 180 m of water bodies are assigned a value of one (1) in the output raster.

#### ***3.2.5.3: Wetland Proximity***

This model creates a raster buffer zone of 180 meters around the statewide VSWI wetland dataset (Figure 3-17). All cells within 180 m of wetlands are assigned a value of one (1) in the output raster.

#### ***3.2.5.4: Stream-Water Body Confluence Proximity***

This model creates a raster buffer zone of 180 meters around nodes classified as stream-water body confluences in the preprocessed statewide VHD hydronode dataset (Figure

3-18). All cells within 180 m of stream-water body confluences are assigned a value of one (1) in the output raster.

#### ***3.2.5.5: Head of Draw Proximity***

This model creates a raster buffer zone of 300 meters around VHD hydro nodes classified as “Head of Draw” (Figure 3-19). All cells within 180 m of head of draw nodes are assigned a value of one (1) in the output raster.

#### ***3.2.5.6: Stream Confluence Proximity***

This model creates a raster buffer zone of 180 meters around VHD hydro nodes classified as Stream-Stream confluences (Figure 3-20). All cells within 180 m of stream-stream confluences are assigned a value of one (1) in the output raster. The model excludes hydronodes manually classified as artificial stream confluences (fall within water bodies; connected to artificial connectors).

#### ***3.2.5.7: Waterfall Proximity***

As shown in Figure 3-21, this model creates a raster buffer zone of 180 meters around mapped waterfalls (VCGI WATCASGO dataset). All cells within 180 m of waterfalls are assigned a value of one (1) and all other areas are assigned a value of zero (0).

#### ***3.2.5.8: Paleo-Lake Soils Proximity***

This model creates a raster buffer zone of 180 meters around all areas covered by soils (VCGI/SSURGO) characterized as Paleolithic Period lake deposits (Figure 3-22). Areas within the 180 m buffer are assigned a value of one (1) and all other areas are assigned a value of zero.

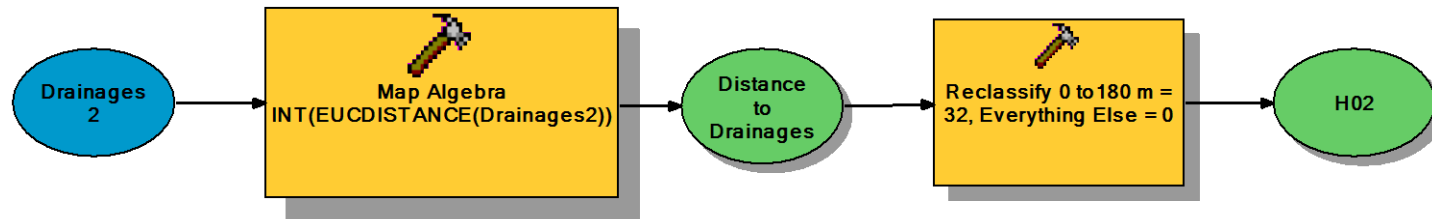

Figure 3-15: Drainage Proximity Model

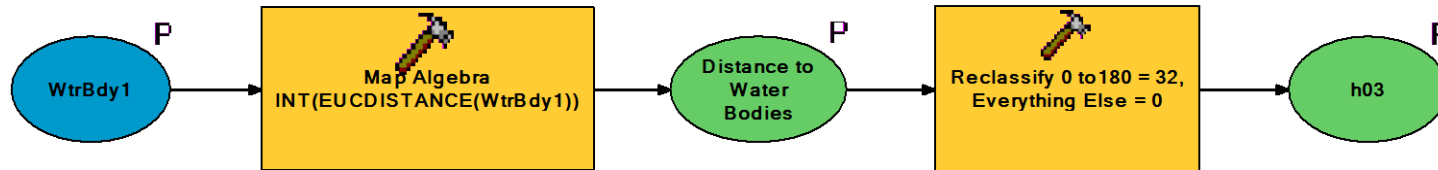

Figure 3-16: Water Body Proximity Model

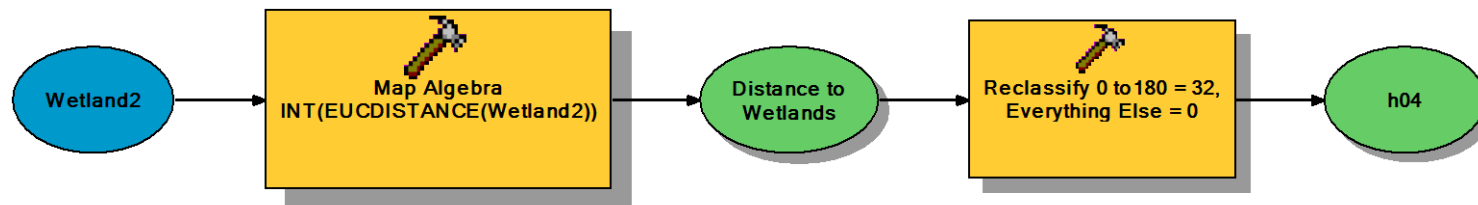

Figure 3-17: Wetland Proximity Model

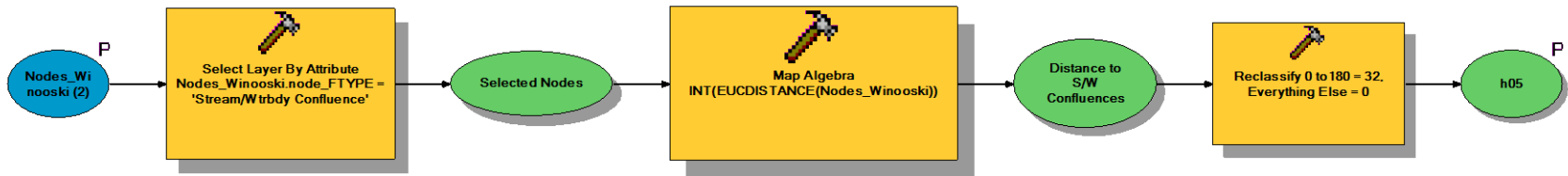

Figure 3-18: Stream-Water Body Confluence Proximity Model

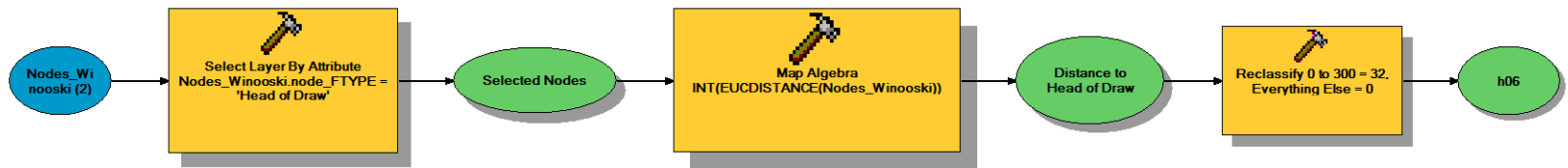

Figure 3-19: Head of Draw Proximity Model

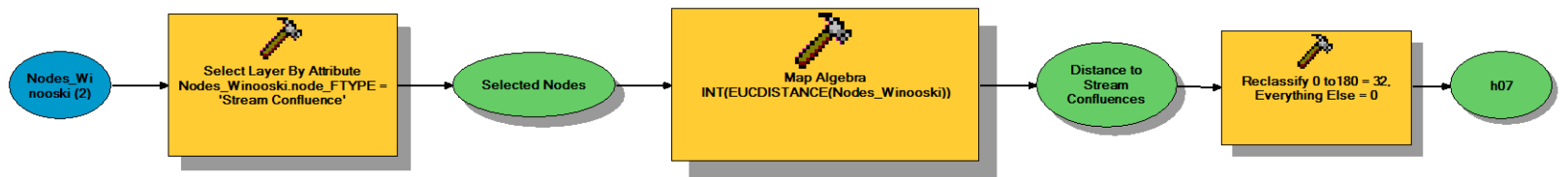

Figure 3-20: Stream Confluence Proximity Model



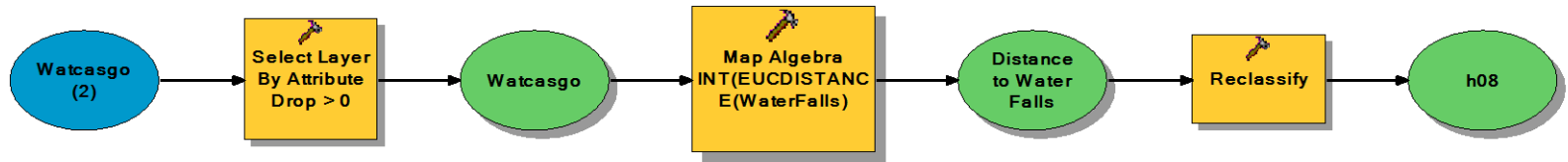

Figure 3-21: Waterfall Proximity Model

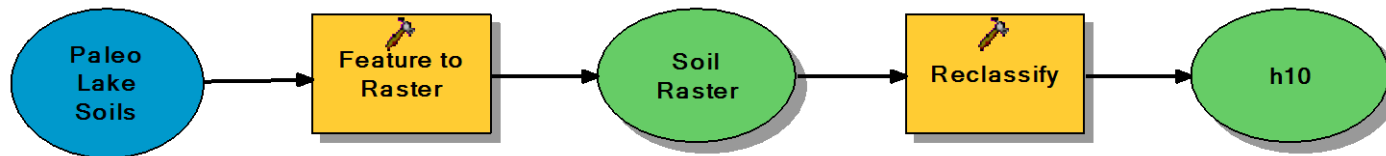

Figure 3-22: Paleo-Lake Soils Presence Model

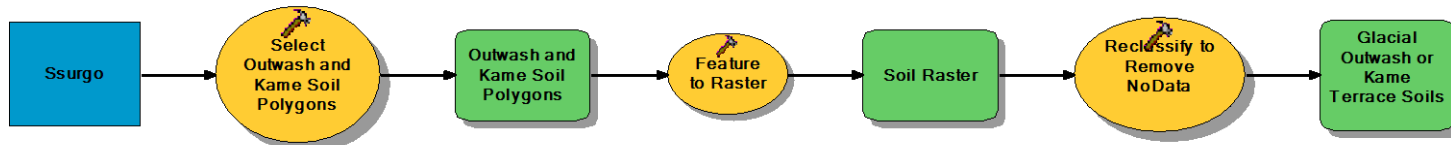

Figure 3-23: Kame Terrace or Glacial Outwash Soils Presence

### ***3.2.5.9: Kame Terrace or Glacial Outwash Soils Presence***

This model creates a raster for areas capped by soils (VCGI/SSURGO) characterized as Kame Terrace or Glacial Outwash deposits (Figure 3-23). All Kame/Outwash soils are assigned a value of one (1) and all other areas are assigned a value of zero (0).

### ***3.2.5.10: Floodplain Soils Presence***

This model creates a raster for the watershed study area in which all areas covered by soils (VCGI/SSURGO) characterized as floodplain deposits are assigned a value of one (1) and all other areas are assigned a value of zero (0).

### ***3.2.5.11: Level Terrain Presence***

In this model, areas characterized by slopes of less than or equal to eight percent are assigned a value of 32 in a raster matching the buffered watershed extent. All areas with slopes greater than eight percent are assigned a value of zero. Inputs to this model consist of the Vermont “hydrodem”, a 10m resolution DEM published in November of 2007 by VCGI (see <http://www.vcgi.org>) and a LiDAR-based 8m DEM for the Chittenden County MPO area. Each dataset is independently converted into a percent slope raster with a resolution of 10 m and the outputs are merged such that the higher resolution dataset (LiDAR-based source data) is superimposed on and replaces the coarser resolution dataset in the output surface. This model also creates a step areas raster used for reference only; this layer is not incorporated in the composite sensitivity layer (Model 12).

### ***3.2.5.12: Statewide Archaeological Sensitivity***

This model uses map algebra to add the eleven binary models described in this section into a final archaeological sensitivity surface with values ranging from 0 to 10, based on the number of overlapping factors associated with archaeological sensitivity. If so desired, the values of each layer can be multiplied by a factor to change the layer's influence (weight) in the output raster. By default, all 11 model inputs are weighted equally yielding a simple additive output.

### **3.2.6: Exploring Statewide Archaeological Sensitivity Model Results**

Several additional models were developed to facilitate quantitative assessment of archaeological sensitivity for specific localities. The analysis toolbox contains three models, two that use a function called zonal statistics to assign sensitivity scores to site point locations and site polygons, and one that facilitates the process of generating geographic masks—rasters that limit analysis extents to specific areas of interest. Figure 3-13 shows the zonal statistics model used for assigning sensitivity scores (based on the Zonal Max) to digitized site polygons. Once the calculation of zonal statistics analysis has been completed, these values can be joined to the digitized site polygons, facilitating the assessment of variability in archaeological sensitivity across documented site boundaries.

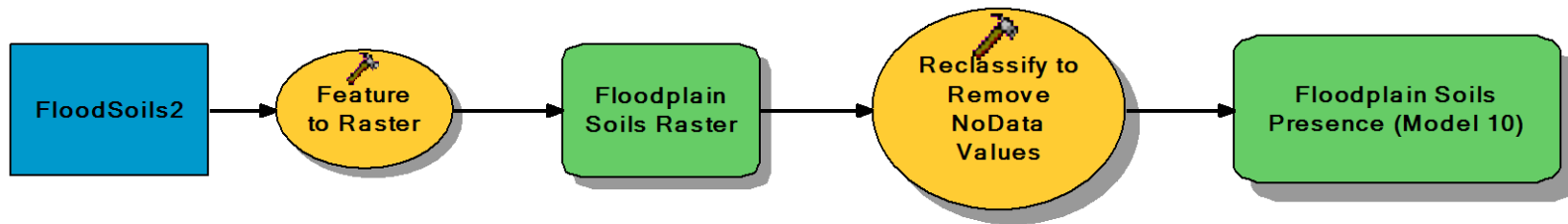

Figure 3-24: Floodplain Soils Presence Model

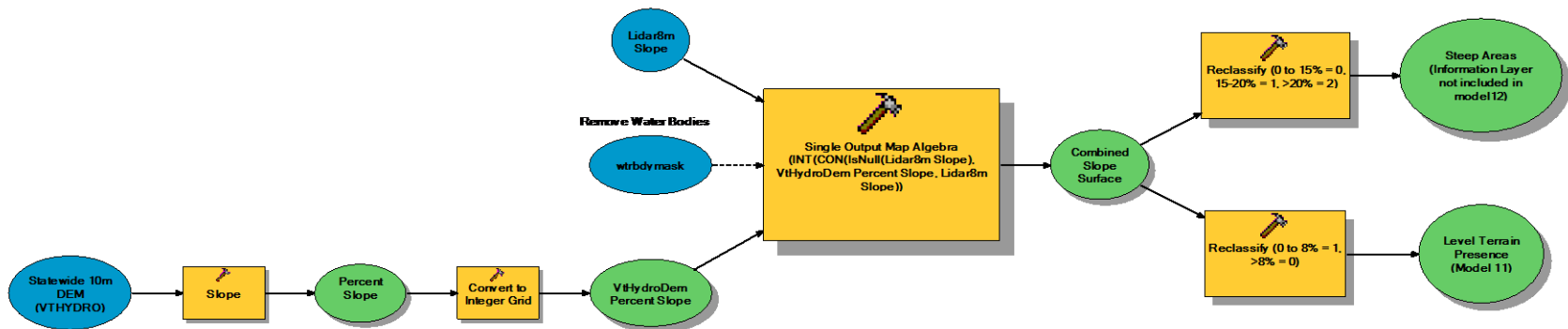

Figure 3-25: Level Terrain Presence Model

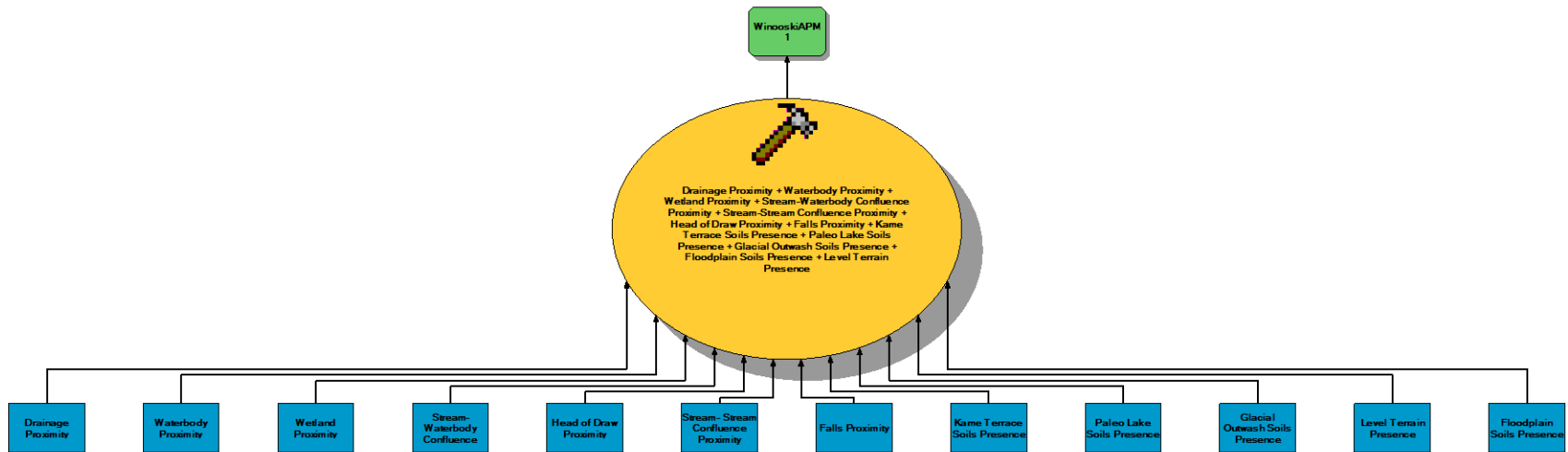

Figure 3-26: Vermont Archaeological Sensitivity Model

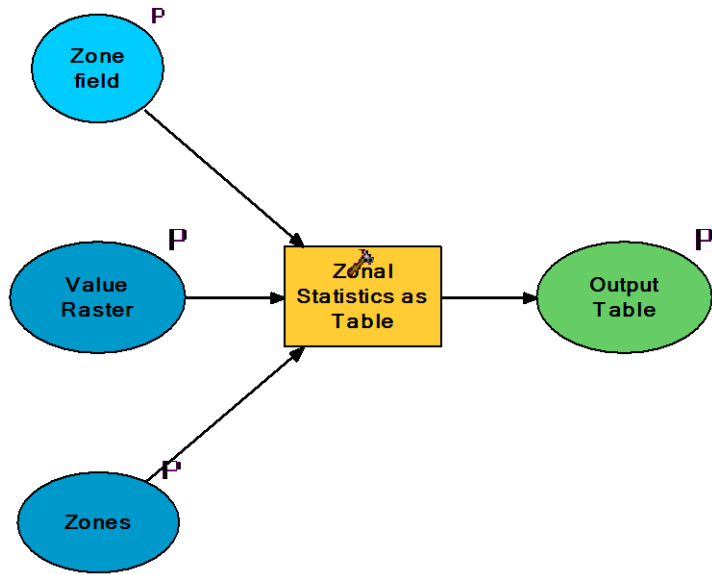

Figure 3-27: VTASM Zonal Statistics Model

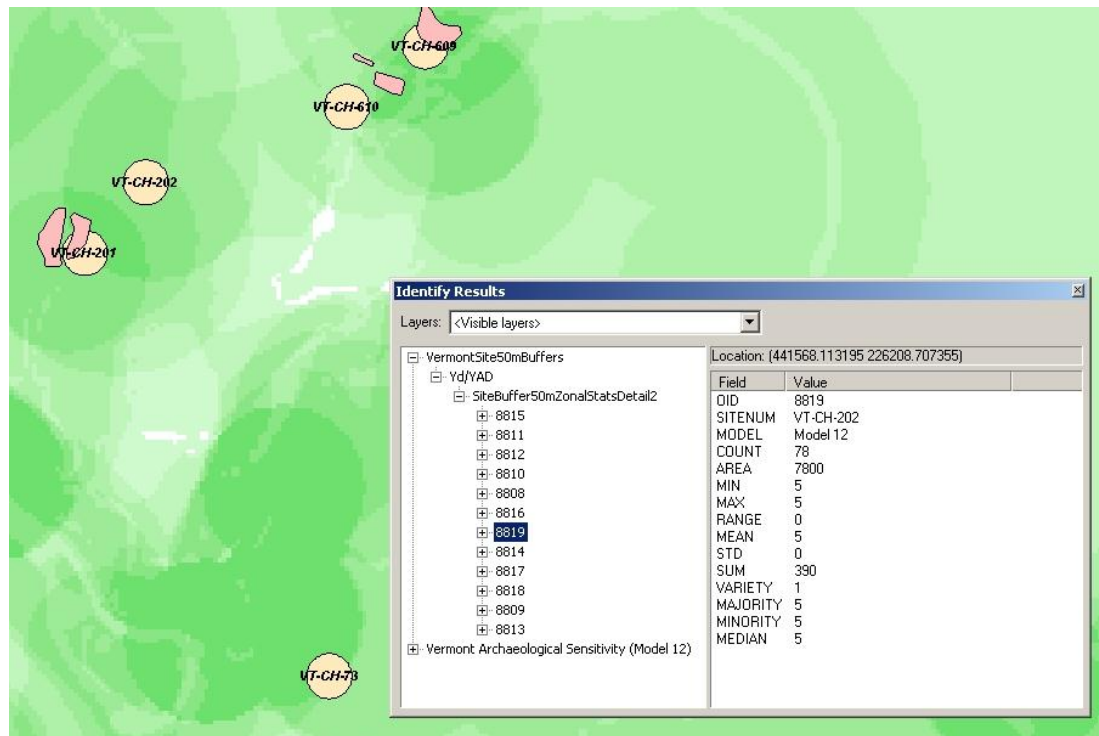

Figure 3-28: VTASM Zonal Statistics Model Results Example

## **CHAPTER 4 - MODELING AGRICULTURAL POTENTIAL IN CHACO CANYON DURING THE BONITO PHASE: A PREDICTIVE GEOSPATIAL APPROACH**

*This chapter is adapted from a draft manuscript that was accepted for publication in the Journal of Archaeological Science, February 2012 (Dorshow 2012).*

### **4.1: Introduction**

The period of emergent social complexity that archaeologists call the “Bonito Phase” (ca. AD 850 to 1150) in Chaco Canyon, New Mexico, in the American Southwest, was the product of an agrarian economy based on the staple crops of maize, beans, and squash together with the likely cultivation and promotion of other plants, such as amaranth, chenopodium and sunflower. Evidence for maize cultivation in the canyon dates to around 2500 BC (Hall 2010; also Simmons 1986), marking Chaco as one of the earliest locales for agriculture currently known in the American Southwest. Although the exact physiological characteristics of maize grown in Chaco are uncertain, there is no question that successful cultivation of any maize variety in the arid Southwest was dependent on adequate water availability. Water is the critical variable determining whether a maize plant germinates and matures, and water is therefore the critical issue in understanding the economic underpinning of the Bonito phase. Additional factors determining the potential success of Bonito Phase farmers in the canyon include slope, landscape position, and soil properties. This study presents a geospatial analysis of Chaco surficial hydrology and geomorphology and their relationship to potential agricultural productivity in order to better understand the economic role of water during the Bonito phase. The results suggest that previous models of agricultural productivity have underestimated local production capacity.

Massive stone buildings called “Great Houses” are the diagnostic feature of the Bonito phase. Some of the dozen great houses in Chaco were built four to five stories in height, particularly the iconic Pueblo Bonito, and incorporated hundreds of thousands of sandstone blocks and tens of thousands of wooden beams within large architectural footprints (Lekson 1984). Interspersed between the great houses are hundreds of small, single-story houses, formal trails and remnants of agricultural fields and water control systems. The large scale and huge investment of human labor testify to complex logistical organizations and the likelihood of some form of managerial elite (Sebastian 1992). Archaeologists assume that the great house community in Chaco was the center of a regional network of agricultural communities dispersed over much of the Colorado Plateau, but there is little agreement about the organization of that network which encompassed models ranging between loosely connected autonomous local populations to a highly centralized administrative apparatus controlling political and economic activity throughout the region (see Vivian 1990; Crown and Judge 1991; Fagan 2005; Lekson 2007).

Presumably such complexity in an agrarian setting was predicated on surplus food production, the surplus thus converted to social labor that was responsible for the construction of the great houses. However, just as the exact nature of Chaco society remains opaque to researchers, so, too, is the exact character of agricultural production. Several researchers have argued that the canyon’s agricultural capacity was inadequate to support the likely residential population (see Benson 2011a, 2011b), even though there are well-documented water control features and at least one large field system in the “downtown” part of Chaco (Vivian 1990). It is perplexing that there should be ambiguity



about agricultural production, or more exactly, that there is not a clearly apparent correspondence between estimated agricultural productivity and cultural production (or proxies thereof, such as buildings and domestic debris). Given the robustness of the archaeological record for high occupational intensity, it is truly unexpected that researchers should be unable to demonstrate a positive relationship with agricultural production.

In the following analysis, I argue that much of this ambiguity disappears when a geospatial analysis of natural variables determining agricultural production is combined with archaeological evidence for a diverse range of production features beyond those documented on the canyon floor. This article presents a predictive geospatial model of agricultural productive potential in the central portion of Chaco Canyon, hereafter referred to as the “Chaco Core”, during the Bonito Phase. Defined within this article as the *Natural Agricultural Suitability Analysis*, the foundation of this study is a hierarchical geospatial analysis that integrates six key natural factors: slope, soil texture, soil depth, non-catastrophic overbank flooding potential, drainage flow length, and drainage proximity and flow potential. These factors are combined through a raster weighted overlay function to generate composite suitability maps showing variability in relative agricultural potential.

Although the rationale for including this set of natural factors is based largely on ethnographic and modern agricultural studies, the predictive model differs from previous studies of agricultural potential in that it is *independent of the specific archaeological distribution of evidence of agriculture in the study area*. In other words, natural factors identify potential field areas without relying on the known distribution of archaeological

evidence for agriculture. Subsequent analysis of the resulting agricultural *Natural Factors Agricultural Suitability Model* includes the summarization of relative agricultural suitability for the project area as a whole, of agricultural suitability by catchment, and of estimated maize yields for arable lands. The accuracy and utility of all of these natural factors are significantly enhanced by a new high resolution elevation dataset acquired through a National Science Foundation NCALM dissertation seed grant awarded to the author in the spring of 2010 (Dorshow 2009).

A secondary analysis overlays cultural landscape factors on potentially arable portions of the study area (raster zones classified as having moderate to high natural agricultural potential) in order to assess cultural factors that may have affected the success of individual plots distributed within potentially *arable areas*. Defined as the *Arable Lands Cultural Feasibility Enhancement Analysis*, this complementary study generates distinct component geoprocessing models (pot-watering feasibility, nutrient addition feasibility, and field management feasibility) as well as a composite geoprocessing model that weights and combines these factors.

These analyses collectively indicate that agricultural production in Chaco during the Bonito Phase was potentially much greater than previous estimates.

#### **4.2: Methods**

The GIS analyses described in this article were conducted using ESRI's ArcGIS 10.0 software leveraging a variety of standard geoprocessing (GIS analysis) tools and custom geoprocessing models (flowchart-like sequences of geoprocessing functions that produce consistent, repeatable results; see ESRI 2012). The following ArcGIS Spatial Analyst tools were employed frequently throughout the analytical process: Euclidean Distance,

Map Algebra, Con, Reclassification, Flow Direction, Flow Accumulation, Flow Length, Slope, Zonal Histogram, and Weighted Overlay (ESRI 2012). The typical analytical sequence generally involves the generation of agricultural suitability rasters comprised of 1 by 1 meter pixels with relative values ranging from zero to five. Higher cell values correlate with high agricultural potential.

#### **4.2.1: Study Area Delineation**

The Chaco Core study area is based on the boundaries of the "Kin Klitzhin Wash-Chaco" hydrologic unit code, (HUC) derived from highest resolution subset (12-digit code) of the National Watershed Boundaries Dataset (Seaber et. al. 1987). This boundary best approximates the Chaco Core in that it encompasses the lower third of Chaco Canyon where most of the Bonito phase great houses are located (Figure 4-1). The study area measures approximately 9,500 hectares in size.

#### **4.2.2: Elevation**

Although most of the Chaco Core study area is covered by a LiDAR-based one-meter resolution digital elevation model (DEM) produced under a Dissertation Seed Grant awarded to the author by the NSF-supported National Center for Airborne Laser Mapping or NCALM (Dorshow 2009), the total upstream drainage basin of the project area extends well beyond the bounds of this high resolution dataset. USGS ten-meter DEM datasets were processed to cover contributing drainage areas not spanned by the LiDAR dataset. The lower resolution elevation data was resampled to match the one-meter cell size of the LiDAR data. Although the vertical resolution of the resampled areas is lower than the central swath of the project area, this solution provided a seamless dataset most suitable for accurate slope and hydrologic analysis.

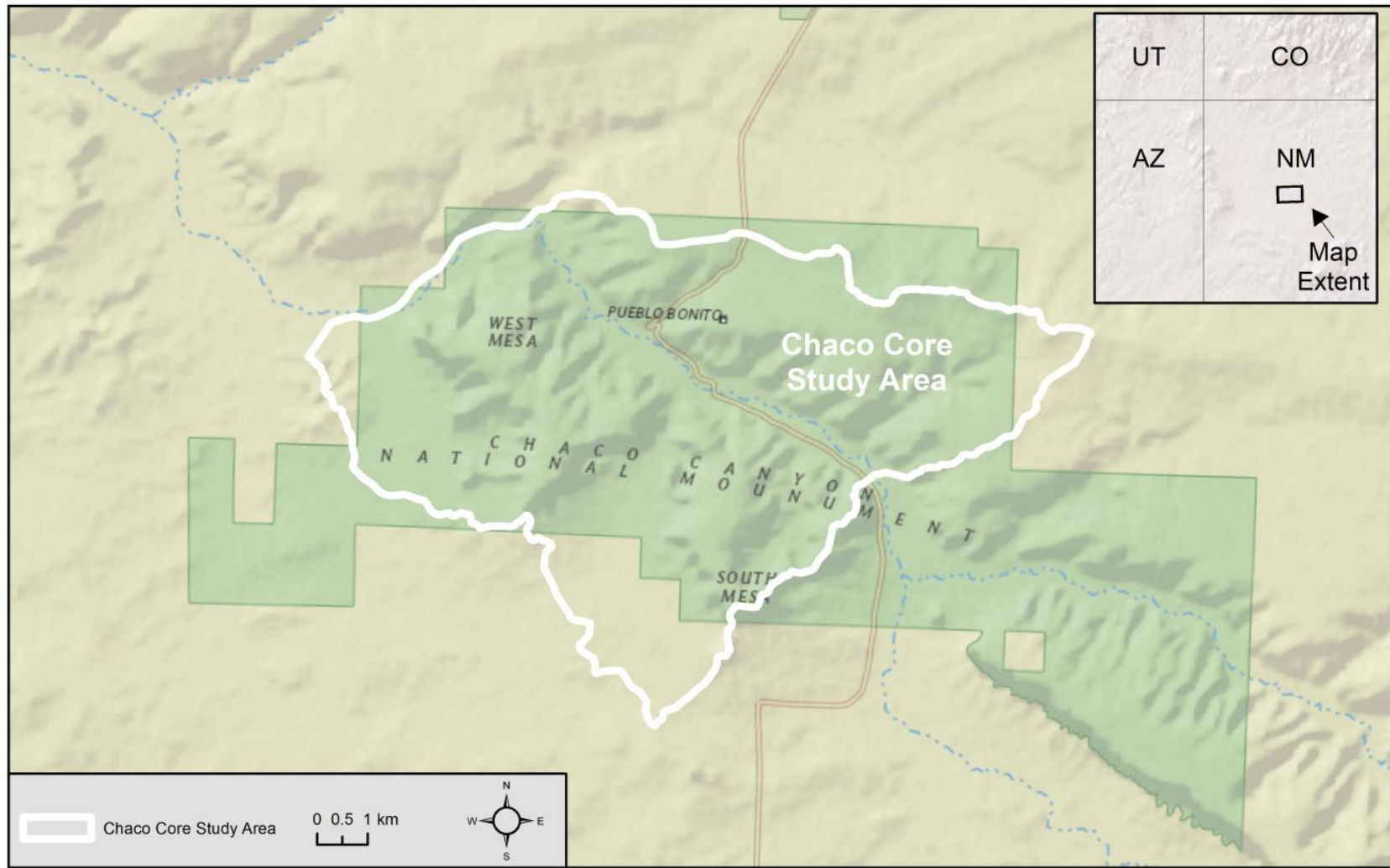

Figure 4-1: Project Location Map (Regional Context)

### **4.2.3: Soils**

Despite the abundance of disparate and localized soils and geomorphic studies of Chaco Canyon, Weide and associates (1979) produced the only comprehensive soil survey providing spatially continuous data that can be used to model soil texture and depth to bedrock in the study. Although this dataset exhibits some minor temporal and spatial inconsistencies (Hall 2010), it nevertheless represents a reasonable proxy for soil texture and general depth on across the study area. The dataset was refined via extensive manual edits of specific soil polygons using the conditioned LiDAR DEM described above and orthophotography. In most cases, the edits entailed re-definition of the boundaries between soil units, particularly along canyon margins and on ridge top benches. The editing process also included recent geoarchaeological data (Wills 2011) as well as the published geomorphic literature (Bryan 1954; Hall 1977, 1988; Love 1980, 1983).

### **4.2.4: Synthetic Hydrologic Modeling**

The synthetic hydrologic modeling process involves the generation hydrologic catchments and stream channels from conditioned elevation data (Maidment 2002). ArchaeoFlow is a custom extension of this procedure; it was created by the author for modeling paleoenvironmental (or archaeological) landscapes that attempt to mitigate effects of post-occupational natural formation processes such as alluviation and modern disturbance (Dorshow 2008, 2010a, 2010b). The ArchaeoFlow analysis sequence began with the production and processing of a modern elevation surface. The next step entails the modification of this conditioned modern terrain through the digital superimposition of archaeologically observed features and stratigraphic contacts (for example, architectural structures, buried occupation surfaces, canal/channels, reservoirs, geomorphic contacts

and unconformities) and the removal of modern disturbances (for example, road cuts). The resulting elevation surface which is a "work in progress" that could be “tuned” based on new findings or differing assumptions in the future is then subjected to a series of analytical processes that generate drainage networks, hydrologic catchments and a flow accumulation surface that approximates upstream drainage area for each raster cell (Maidment 2002).

In preparation for modeling and evaluating natural agricultural potential throughout the study area, I processed the NCALM-derived LiDAR DEM to generate a hydrologically correct terrain representative of the Bonito Phase. This process involved the use of multiple geoprocessing functions contained within the ArcGIS 10.0 toolkit and conformed to the best practices for synthetic hydrologic modeling detailed by Maidment (2002). A custom geoprocessing toolset was developed to automate the entire terrain processing and hydrologic modeling process, which includes the following: sink removal, flow direction analysis, flow accumulation analysis, and flow accumulation reclassification (Figure 4-2). This model was re-run after each round of terrain modifications aimed at removing modern disturbances.

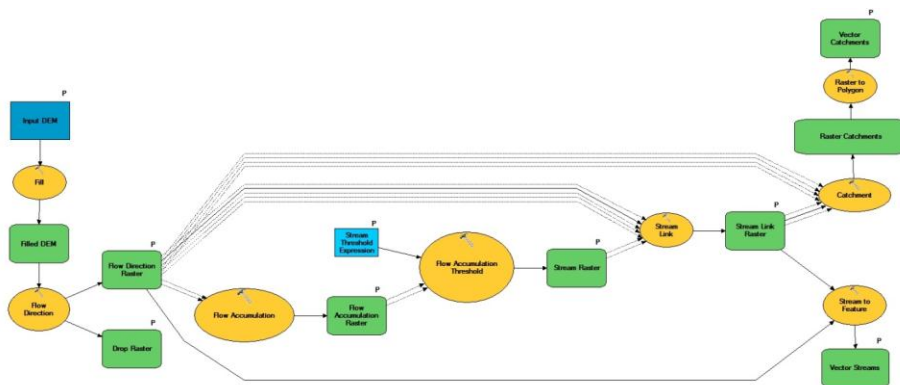

Figure 4-2: Synthetic Hydrological Terrain Geoprocessing Model

Figure 4-3 shows the drainage network and catchments generated using a minimum upstream drainage area threshold of 40,000 square meters. The catchments are labeled with identification and total drainage area values. The white dots are the locations of Great House sites included for reference purposes.

#### **4.2.5: Archaeological Site Data**

Archaeological site location data derived from a custom query of the New Mexico Archaeological Records Management System database (ARMS) was used (1) to evaluate the Natural Agricultural Suitability results and (2) as inputs to two of the component geoprocessing models included in the Arable Lands Cultural Enhancement Feasibility Analysis. Again, archaeological information *was not* used as a contributing factor in the predictive Natural Agricultural Suitability Analysis described in the following section.

Using a buffer covering most of the northwestern part of New Mexico, I extracted site location points and basic site-form information for all time periods, along with associated tabular data from the ARMS Site Component and Feature tables. Sites with temporal ranges spanning the Bonito Phase and falling within the Chaco Core study area were selected from this larger sample for further analysis and evaluation. In several cases, this dataset was further parsed based on the presence/absence of Great Houses, structures and/or probable agricultural features.

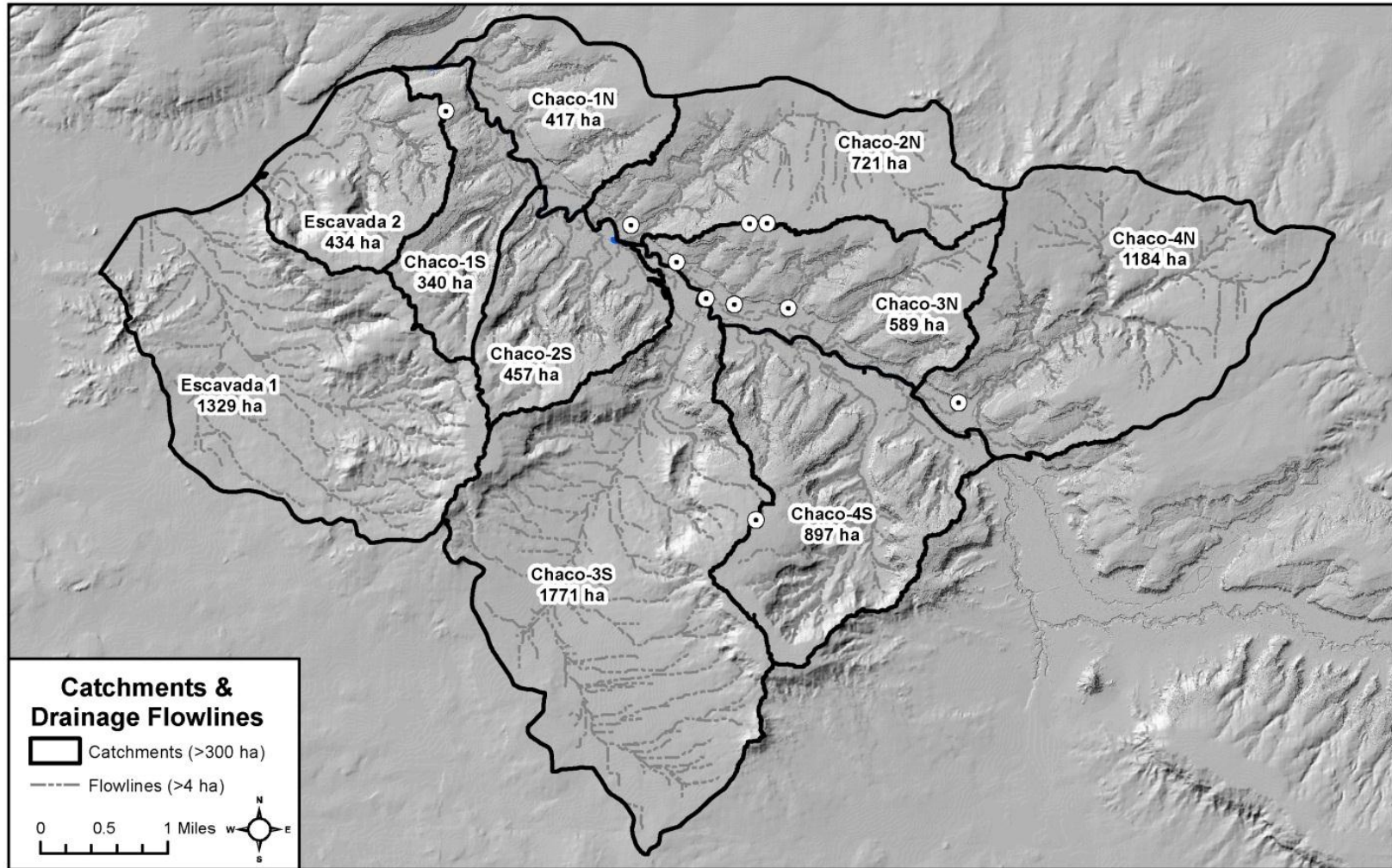

Figure 4-3: Drainages and Catchments in the Chaco Core Study Area



### **4.3: Natural Agricultural Suitability Analysis**

The assessment of Bonito Phase agricultural potential begins with a predictive geospatial analysis of Bonito Phase agricultural potential that integrates six key natural factors: slope, soil texture, soil depth, drainage flow-length, non-catastrophic overbank flooding potential, and drainage proximity and flow potential. Using a hierarchical geoprocessing framework described elsewhere (Dorshow 2008, Dorshow 2010a, Dorshow 2010b) a separate "Component Geoprocessing Model" is dedicated to each analysis criteria. These Component models are then wrapped up in a "Composite Geoprocessing Model" representing overall agricultural suitability holding all other factors constant.

Table 4-1 provides a summary of the Natural Agricultural Suitability Analysis Framework. It includes brief criteria descriptions, source data information, weighting factors (relative contribution of each component geoprocessing model in the weighted overlay for the composite geoprocessing model), and suitability scores (component geoprocessing model ranks) for each criterion. Given their dominant importance in natural agricultural potential (Dominguez and Kolm 2005; Kirkby 1973), holding water availability constant, I chose to give the slope and soil texture component geoprocessing (GP) models twice the weight of the other three factors in the final Natural Agricultural Suitability composite geoprocessing model. Note that all of the variables in the weighted overlay model are related to water in some way or another.

Table 4-1: Natural Agricultural Suitability Analysis Summary

<b>Composite GP Model Weight</b>	<b>Analysis Criteria</b>	<b>Data Categories</b>	<b>Suitability Score</b>	<b>Input Data and Remarks</b>
25%	Slope Suitability	0 to 10%	5	Percent slope derived from conditioned one meter resolution DEM derived from 2010 NCALM LiDAR campaign (Dorshow 2009, 2010b); Data gaps replaced with ten meter DEMs from the USGS (National Hydrographic Dataset, 2011; Simley and Carswell 2009). Terrain data was edited to remove roads, paths and water diversion structures that are clearly historic (Dorshow 2010b)
		10 to 15%	4	
		15 to 20%	3	
		20 to 30%	2	
		> 30%	0	
25%	Soil Texture Suitability	Sand Dominated	5	Soils data from the Natural Resource Conservation Service (Weide et al. 1979); Chaco Soils Study Data and UNMCSP field data; Soil boundaries were edited manually using composite, conditioned one meter DEM, aerial photos, and other geomorphic data and field observations (Dorshow 2010b).
		Silt Dominated	3	
		Clay Dominated	1	
		Rock/Water	No Data	
12.5%	Depth to Bedrock Suitability	> 3 m	5	Same dataset and processing as described above (Soil Texture); (Dorshow 2010b).
		1 to 3 m	4	
		50 to 100 cm	3	
		10 to 50 cm	2	
		0 to 10 cm	1	
12.5%	Flow Distance Suitability (Escavada Wash)	> 3.5 km	5	Conditioned one meter DEM (Dorshow 2009, 2010b)
		2 to 3.5 km	4	
		1 to 2 km	3	

Composite GP Model Weight	Analysis Criteria	Data Categories	Suitability Score	Input Data and Remarks
		500 to 1000 m	2	
		< 500 m	1	
12.5%	Overbank Flooding Suitability (Non-catastrophic)	Chaco Canyon Floor	5	Conditioned one -meter, soils data, and imagery DEM (Dorshow 2009, 2010b)
		Major Chaco Tributary Canyon Floor	4	
		Moderate Drainage Margin	3	
		Minor Drainage Margin	2	
		Other Areas	0	
12.5%	Drainage Proximity and Flow Potential	Flow Length <= 700 m; Drainage buffer distance = 50 m	5	Conditioned one meter DEM (Dorshow 2009)
		Flow Length >0.7 km and <1.4 km; Drainage buffer distance = 40 m	4	
		Flow Length > 1.4 km and <2.8 km; Drainage buffer distance = 30 m	3	
		Flow Length >2.8 km and < 5.6 km; Drainage buffer distance = 20 m	2	
		Flow Length >5.6 km; Drainage buffer distance = 10 m	1	
100%	Natural Agricultural Suitability Composite Geoprocessing Model	Very High Agricultural Potential	5	Weighted Overlay using the six Natural Agricultural Suitability component models listed above.
		High Agricultural Potential	4	
		Moderate Agricultural Potential	3	
		Low Agricultural Potential	2	
		Very Low Agricultural Potential	1	

#### **4.3.1: Slope Component Geoprocessing Model**

Slope constrains maize cultivation. Kirkby (1973) suggests it is unlikely that maize would have been grown on slopes greater than 16 percent. Generally, dry land farming in non-terraced contexts would likely have been restricted to relatively level terrain. The Slope Suitability component geoprocessing model sequence began with the calculation of a percent slope surface from the conditioned one-meter DEM. The slope surface was then reclassified into five classes of relative slope suitability for agriculture. Figure 4-4 shows the results of this analysis.

#### **4.3.2: Soil Texture Component Geoprocessing Model**

Dominguez and Kolm (2005:752), echoing observations by Clark (1928:235) and Bradfield (1971:17), point out that soil texture is a key factor in field site selection among traditional Hopi agriculturalists, who favor sand-dominated soils underlain by less permeable sediments or sandstone bedrock. In well-drained sands, water is more likely to be rapidly absorbed and stored at the boundary with an underlying less-permeable horizon, rather than it is to be transported across the ground surface. The “alternation of very fine with coarse layers creates a series of permeability and capillary barriers that retard the vertical movement and loss of water”. Dominguez and Kolm (2005:751) Moreover, the Hopi focus on a “midsoil” where silt and loam layers retain higher levels of moisture conductive over a range of hydraulic head values (Dominguez and Kolm 2005:748; see also Sandor et al. 2007:373).

Previous geological research in the canyon indicates that mesa top sediments are mainly aeolian deposits resting on an impermeable bedrock substrate, while alluvial sand deposits typically are characterized by interbedded lenses of clay and silt (Love 1980, 1983; Hall 1977). Observations by geologists for over 70 years indicate that sand-dominated alluvial sediments on the canyon floors are characterized by alternating sequences of fine sands, clays and silts. Sand deposits typically exhibit a range of particle sizes (typically sand loams and loamy sands) within discrete layers.

Consequently, while the spatial resolution of the soils data used in this study is relatively coarse, I am confident that general trends related to agricultural potential can be extracted from the soil texture data used for the study.

The Soil Texture Component Geoprocessing Model generates a five class suitability raster in which cell values vary with soil grain size. In general, loamy to sandy soils are the most favorable, while fine grained sediments are less favorable for agriculture. Table 4-2 provides a detailed breakdown of the soil texture classes assigned to each soil texture agricultural suitability class, and Figure 4-5 shows the spatial distribution of the suitability classes across the study area.

Table 4-2: Soil Texture Classification Schema

<b>Dominant Soil Texture</b>	<b>Suitability Score</b>	<b>Dominant Soil Texture</b>	<b>Suitability Score</b>
Fine Sandy Loam	4	Rock and Rocky Loam	1
Loam to Sandy Loam	4	Loamy Sand	4
Fine Sand	4	Silty Clay Loam	2
Silt Loam	2	Loam to Fine Loam	3
Loam	3	Sand	5
Loamy Fine Sand	5	None	0
Coarse Loam	3		

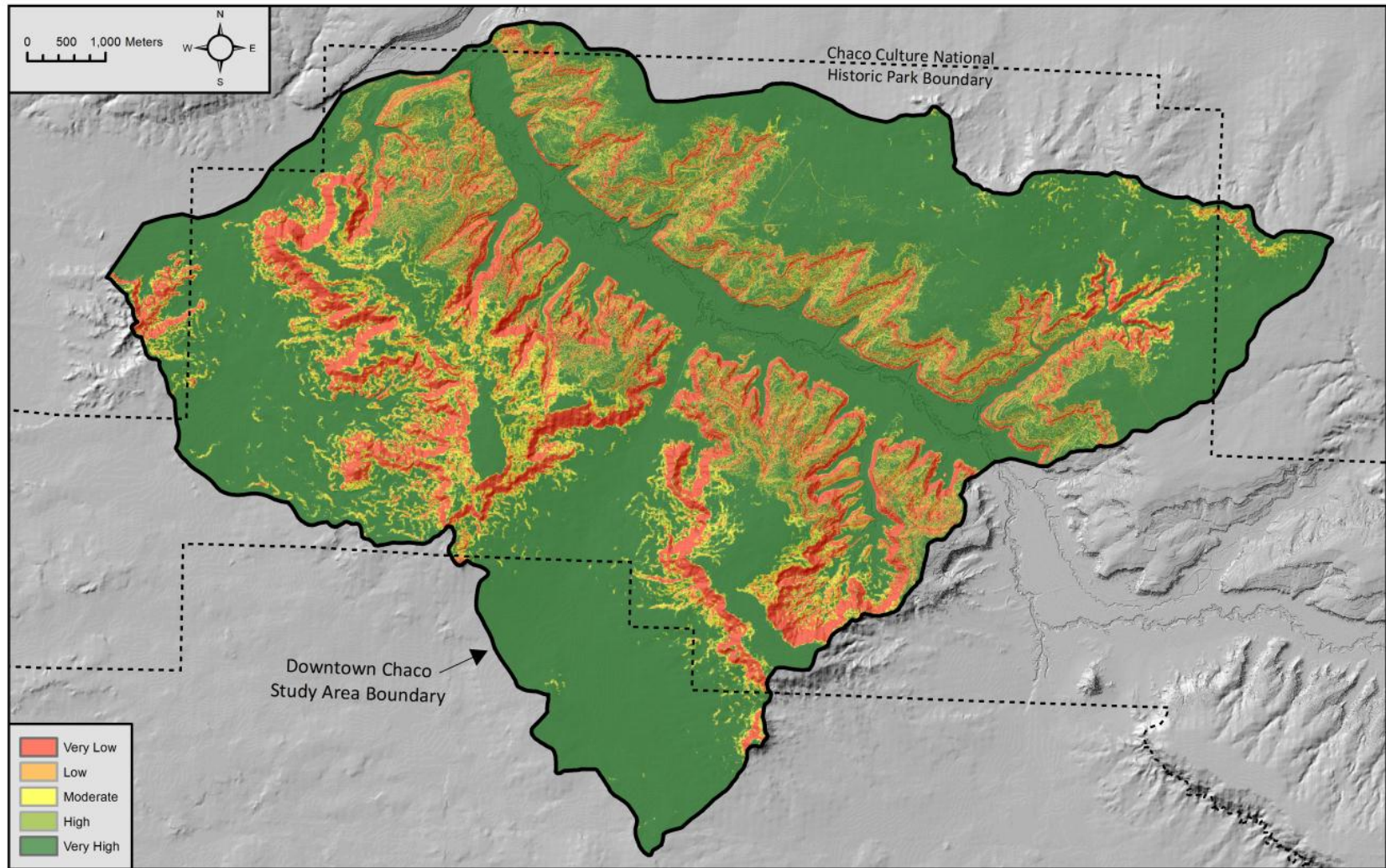

Figure 4-4: Slope Agricultural Suitability Analysis Results

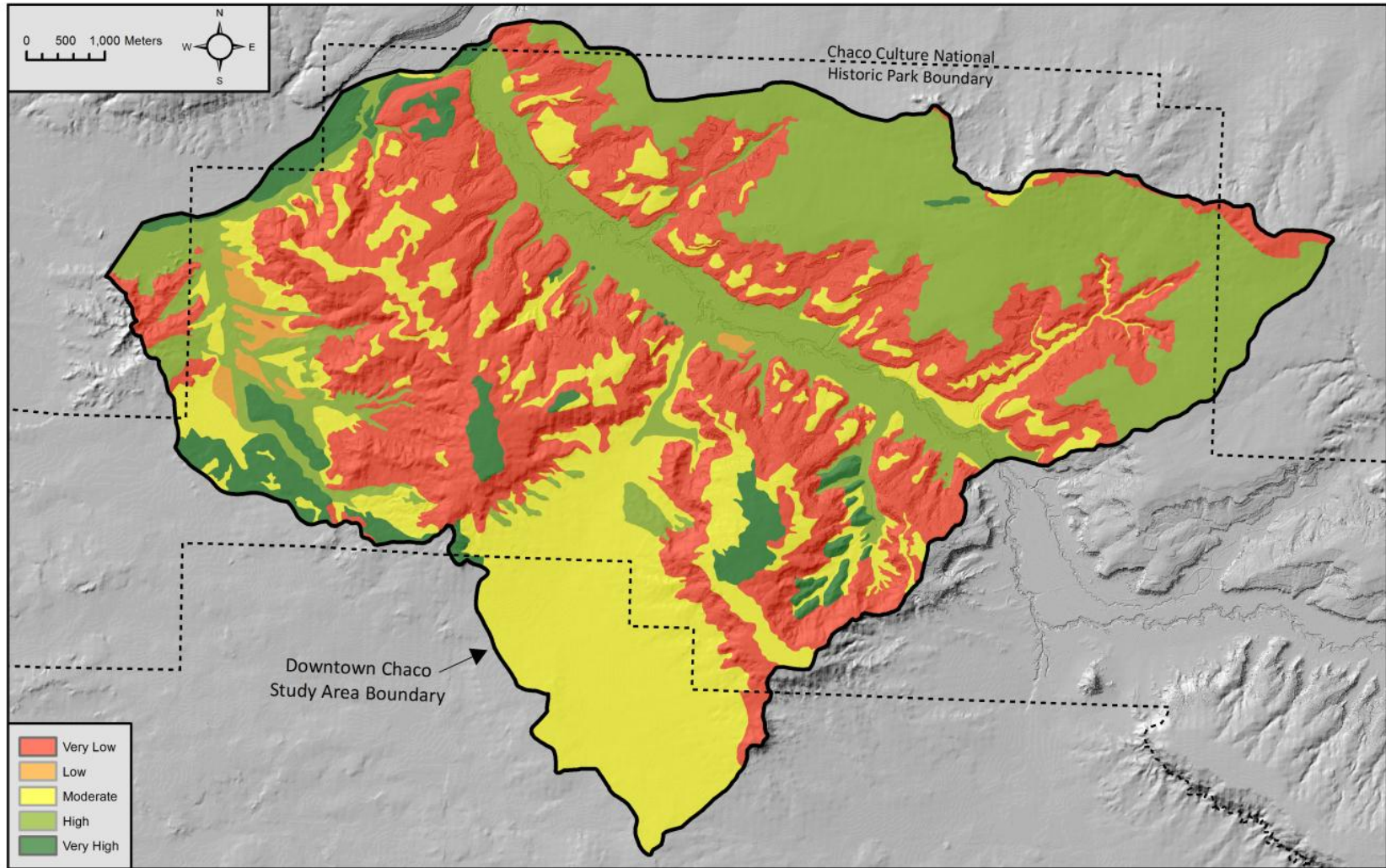

Figure 4-5: Soil Texture Agricultural Suitability Analysis Results

### 4.3.3: Depth to Bedrock Component Geoprocessing Model

The water holding/runoff potential of different soils and parent materials within the study area is partially a function of depth to bedrock. For the purposes of this initial agricultural potential analysis, drawing on ethnographic observations, deeper soils are assumed to be more viable for agriculture (Dominguez and Kolm 2005; Forde 1931). Very thin soils and bare areas are not viable for agriculture, whereas thicker and well-developed soils facilitate the absorption of surface water in the vicinity of plants.

The Depth to Bedrock Component Geoprocessing Model aggregates soils based on the “MaxDepth” field in the enhanced CPNHP soils polygon dataset described in the previous section. This produces a raster comprised of five classes of relative depth. Figure 4-6 shows the results of the Depth to Bedrock geoprocessing tool. Table 4-3 shows the breakdown of the five depth-based classes.

Table 4-3: Depth to Bedrock Classification Scheme

<b>Depth</b>	<b>Suitability Score</b>
> 3m	5
2 -3m	4
1-2 m	3
< 1m	2
0 to 25 cm	1



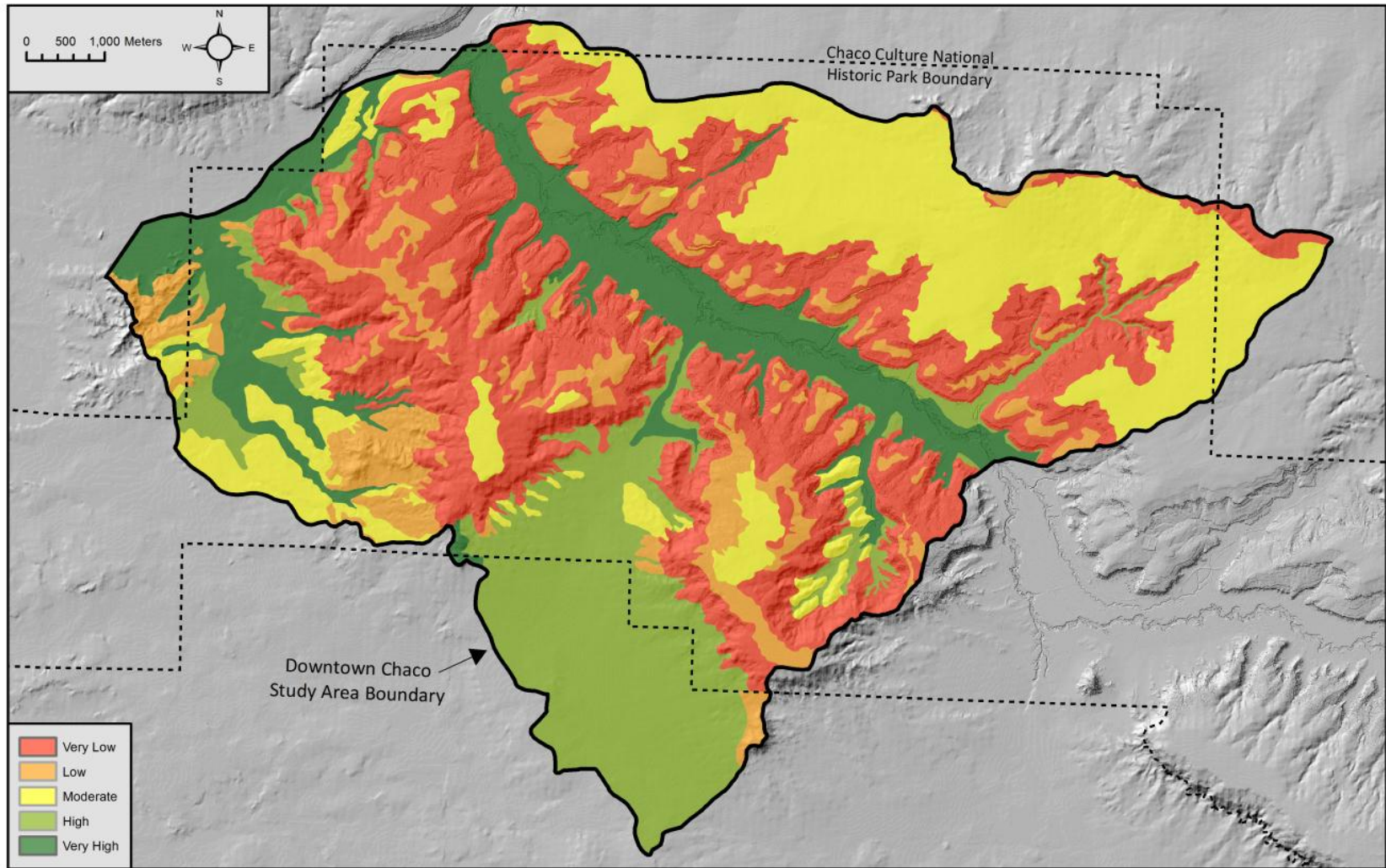

Figure 4-6: Depth to Bedrock Agricultural Suitability Analysis Results

#### **4.3.4: Flow Length to Escavada Wash Component Geoprocessing Model**

Holding all other agricultural suitability factors equal, downstream areas receive accumulated water from upstream areas and therefore have a higher potential to meet the water requirements for maize agriculture. Within the study area, smaller tributary drainage channels and side-canyon floors that are closer to the Chaco or Escavada washes receive a significant amount of non-channelized runoff from thinly covered rocky slopes that encompass them. I hypothesize that the proportion of runoff that actually makes it into channelized drainages is higher with increasing proximity to the main study area washes. While not the focus of this paper, further testing of this preliminary hypothesis is warranted to guide the next, enhanced and refined version of the Natural Agricultural Suitability Analysis framework.

To model this variable, I conducted a flow length analysis for the study area, which drains into the Escavada Wash to the west. This Escavada Wash flow length analysis generated a raster in which pixel values represent the cumulative distance downstream along the natural hydrologic flow path of each cell to the basin or catchment outlet. In this case, the analysis was based on flow length to the mouth of Chaco Canyon, where the Chaco Wash joins the larger Escavada Wash. Figure 4-7 shows the results of the reclassification of flow length values into five classes where higher scores represent lower reaches of the watershed and lower scores represent areas farther upstream.

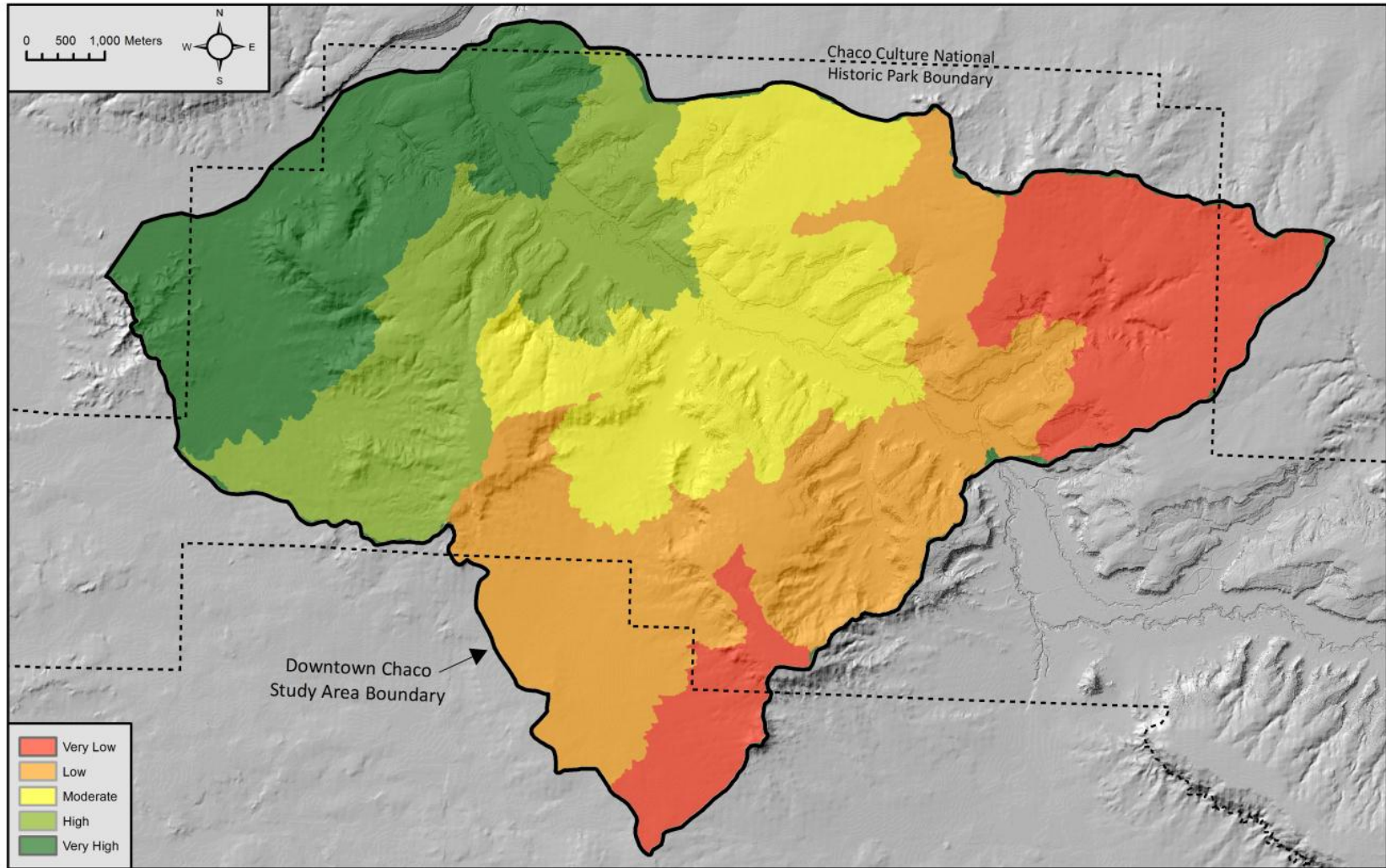

Figure 4-7: Flow Length to Escavada Wash Agricultural Suitability Analysis Results

#### **4.3.5: Overbank Flooding Potential Component Geoprocessing Model**

As defined here, overbank flooding potential is a geospatial proxy for the relative potential for non-catastrophic overbank flooding in a given area. This analysis component does not consider the negative impacts of catastrophic flooding for low lying field areas. Instead, the focus is on the *benefits* associated with periodic flooding of field locations. Areas along upland streams and lowland floodplains are subject to periodic flooding unless drainages are significantly incised and therefore isolated from overbank flooding.

To evaluate this natural agricultural suitability factor, I buffered *modern* drainages and floodplain contexts defined using soils, hydrology and other geomorphic information to generating a five-class suitability raster. In the output raster, cells with high suitability scores represent zones subject to non-catastrophic overbank flooding. Figure 4-8 shows a map of relative suitability for the overbank flooding potential suitability variable.

While it is becoming increasingly possible to model a range of hydrologic scenarios enhanced by geospatially integrated geomorphic information for the study area, this analysis is based on the modern-day Chaco landscape, which is characterized by *significant* channel incision. Currently, the main Chaco wash runs in a channel that is more than 3 m below the broad canyon floor. As such, overbank flooding from the main channel is far rarer than overbank flooding associated with less deeply incised secondary drainages (many have little or no channel incision). This incised context is captured in the enhanced soils dataset (Weide et al. 1979) and 2010 LiDAR DEM terrain surface used to model overbank flooding potential for this study.

For an aggraded or semi-aggraded scenario, which has been suggested for the later Bonito phase (Force et. al. 2002), the same GIS model used to generate Figure 4-8 would yield an output surface characterized by even greater total agricultural potential because more area would be subjected to regular non-catastrophic overbank flooding. Much of the area classified as moderate and high suitability would likely be lumped into the high or very high natural agricultural suitability classes. For example, had I modeled a non-incised hydrologic setting, which may or may not have characterized the Bonito phase, areas adjacent to the main Chaco wash would have received higher agricultural potential scores. This is because the broad canyon floor would have been subject to more frequent overbank flooding from the non- or minimally incised main wash.

#### **4.3.6: Drainage Proximity and Flow Potential Component Geoprocessing Model**

The remaining factor in Natural Agricultural Suitability Analysis Framework--Drainage Proximity Suitability and Flow Potential--is a proxy for both drainage proximity and upstream drainage area (flow accumulation). While the additional emphasis on flow length in this case might seem counterintuitive, it is included in this analysis for reasons described in the rationale for the stand-alone Flow Length suitability model (Section 3.1.5). In this case, total upstream drainage area (flow accumulation) for each pixel is the primary source of the five-class agricultural suitability score assignment, but proximity to major channels also has some influence.

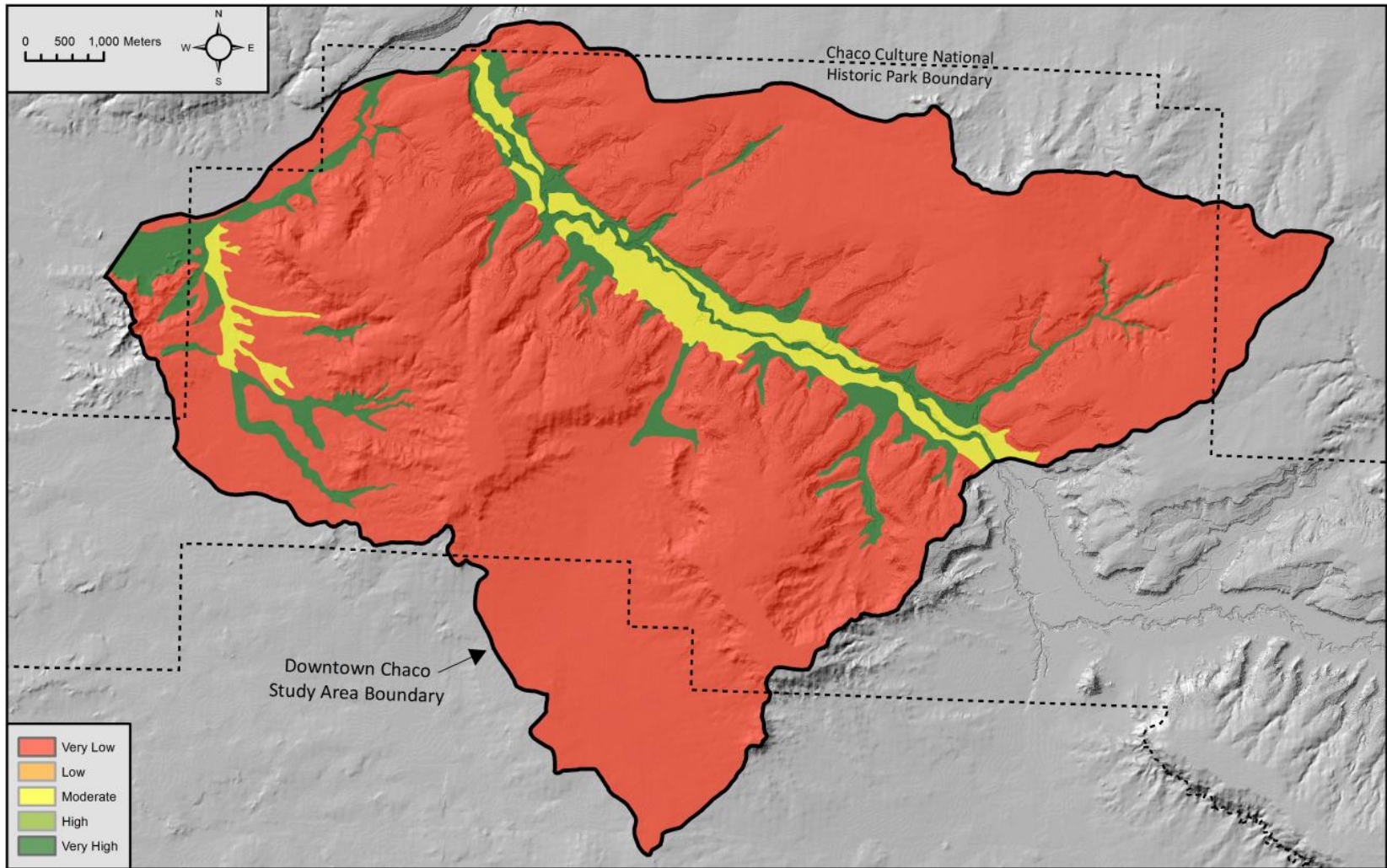

Figure 4-8: Overbank Flooding Potential Analysis Results

Modeling the role of proximity to drainages and relative flow accumulation potential at any given point across the landscape involved several steps. The analytical sequence began with the generation of a series of five concentric zones of relative flow distance from the closest primary drainage in the study area, Chaco Wash, for all of the study area sub-basins with the exception of CWS1, which actually feeds the Escavada Wash. Next, drainage channels with a minimum drainage threshold of 40,000 km<sup>2</sup> (generated from the conditioned LiDAR DEM as described in the Methods Section) were then intersected with the drainage distance surface to merge the primary distance zone information with the segments themselves. Subsequently, drainage segments were buffered based on the values shown in Table 4-4. Figure 4-9 shows the results of this analysis.

Table 4-4: Drainage Proximity and Flow Potential Agricultural Suitability Classification

<b>Flow Length to Closest Primary Drainage</b>	<b>Drainage Buffer Distance</b>	<b>Natural Flow Accumulation Suitability</b>
700 m	50	5
1400 m	40	4
2800 m	30	3
5600 m	20	2
>5600 m	10	1

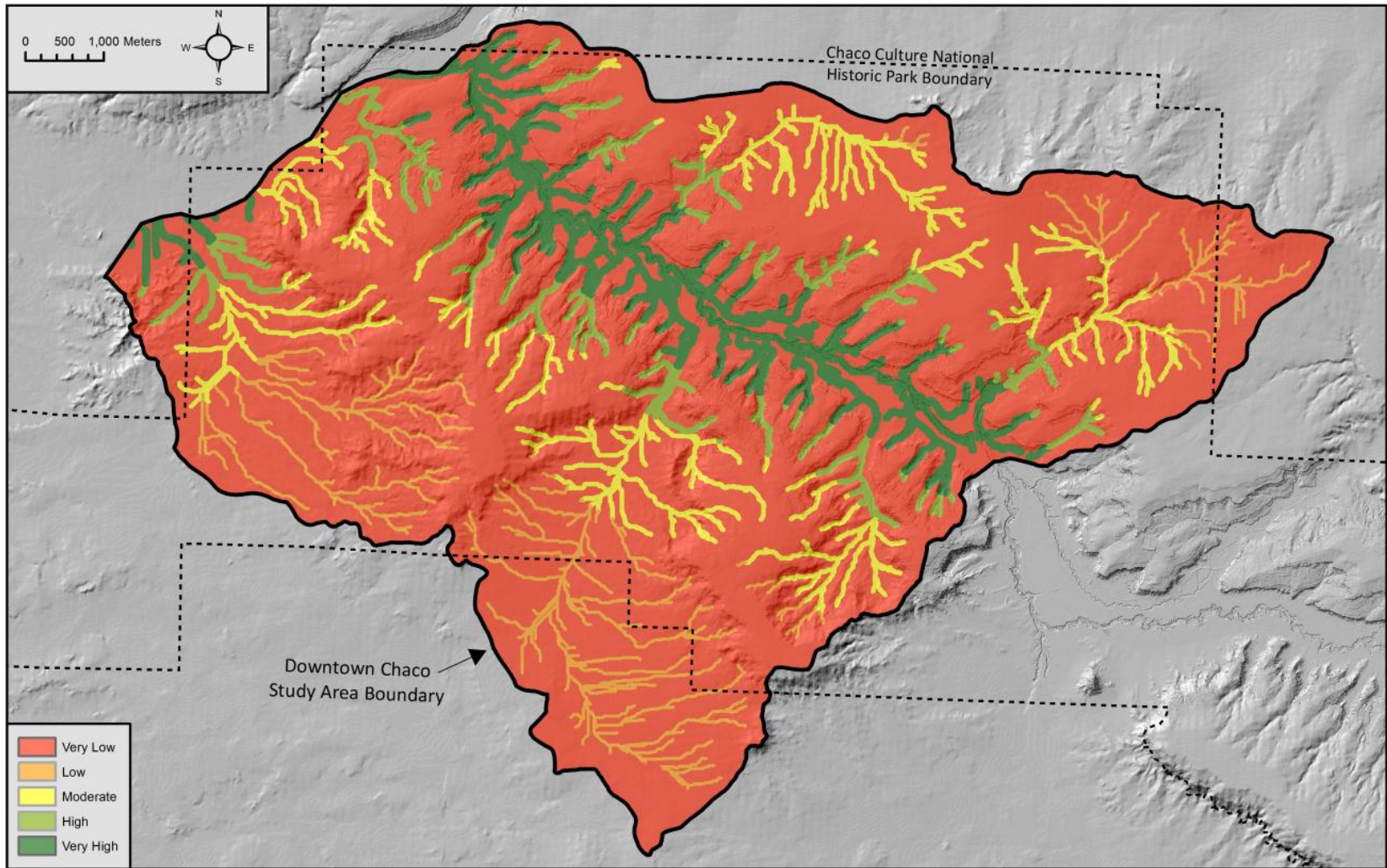

Figure 4-9: Drainage Proximity and Flow Potential Analysis Results



#### **4.3.7: Natural Agricultural Suitability Composite Geoprocessing Model**

Figure 4-10 shows the results of weighted overlay analysis combining the five individual natural factors. Given the overarching importance of slope and soil texture, these two factors were given twice the relative weight of the other three factors. The specific map algebra function used in the raster weighted sum is as follows: (Slope \*2) + (Soil Texture Suitability \* 2) + Depth to Bedrock + Flow Length to Escavada Wash + Overbank Flooding Potential + Drainage Proximity and Flow Potential. A high resolution graphic showing Figures 4 through 10, side-by-side, at a larger map scale, is available here: [http://www.earthanalytic.com/DorshowJAS414\\_Poster1.pdf](http://www.earthanalytic.com/DorshowJAS414_Poster1.pdf).

For each of the five suitability classes defined by the Natural Agricultural Composite Geoprocessing Model, Table 4-5 summarizes size (hectares) and relative proportion (percent) of the study area. While these results are subject to varied interpretation, I suggest that lands belonging to the moderate, high and very high suitability classes should be considered potential field locations. Combined, these three classes cover nearly 5,000 hectares, representing over 60% of the Downtown Chaco study area. Clearly, not all terrain within these moderate to high scoring zones represent field areas, but these zones are worthy of systematic inspection to assess independent archaeological evidence of agriculture. This initial analytical approach will later be refined using raster filtering algorithms to remove noise and define contiguous zones of high agricultural potential. These steps will help to define specific predictions of contiguous field areas for field testing. An example of this approach is presented in Section 3.3.

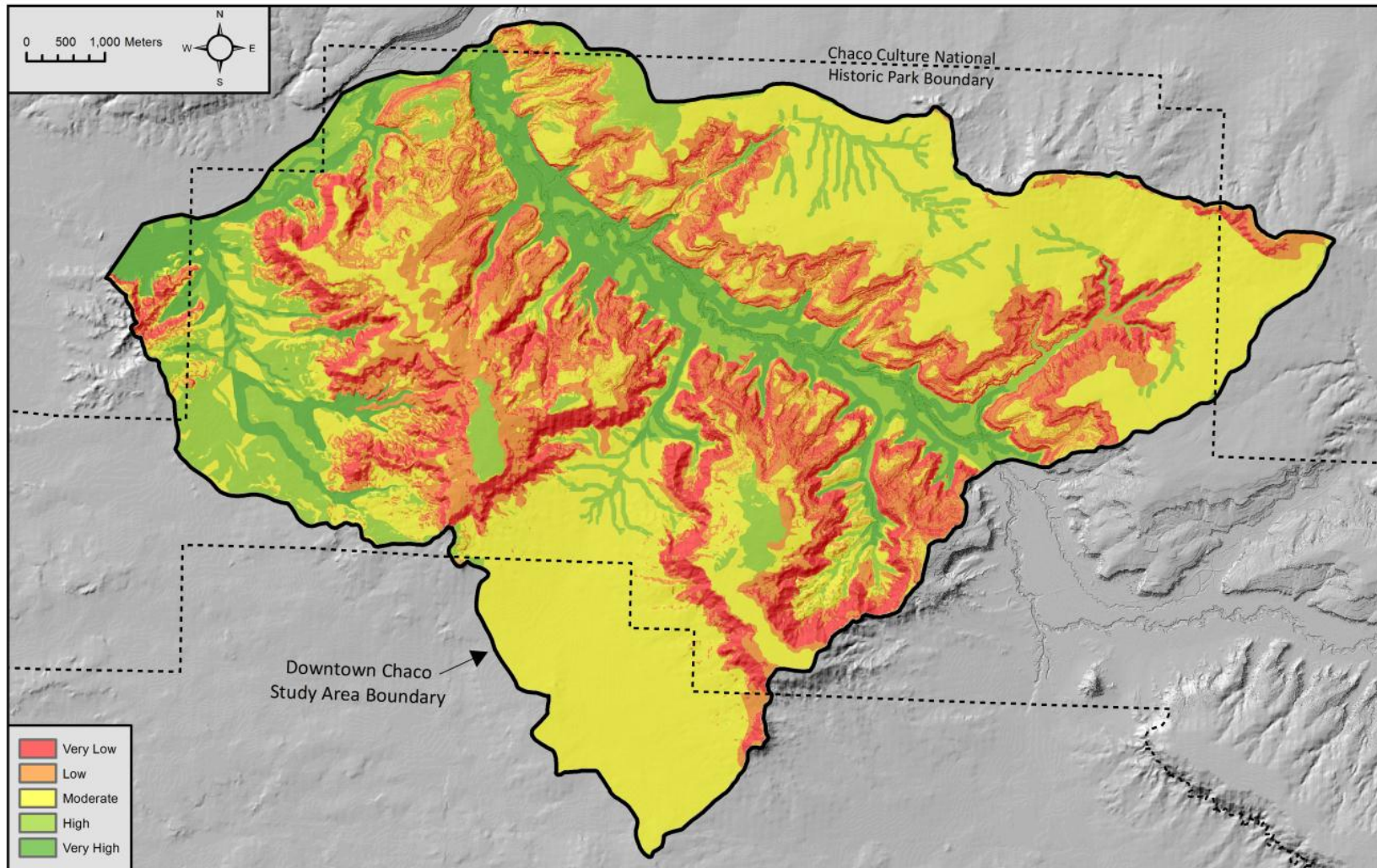

Figure 4-10: Natural Agricultural Suitability Analysis Results

Table 4-5: Natural Agricultural Suitability Analysis Summary

Suitability Class	Hectares	% of AOI
Very Low (1)	1,419.80	17.66%
Low (2)	1,729.73	21.52%
Moderate (3)	3,066.66	38.15%
High (4)	1,038.74	12.92%
Very High (5)	783.51	9.75%

Figure 4-11 summarizes the results of a zonal histogram analysis that calculated the number of pixels that occur within each of the five natural agricultural suitability classes. Using the area values (summed from numbers of pixels) for each suitability class within each catchment, I ran a series of chi square analyses to examine this spatial variability. When the six of the catchments that drain into Chaco Wash are included in the contingency table analysis, there is a significant difference in agricultural suitability score by catchment ( $X^2 = 1480$ ,  $df = 28$ ,  $p < .0001$ ).

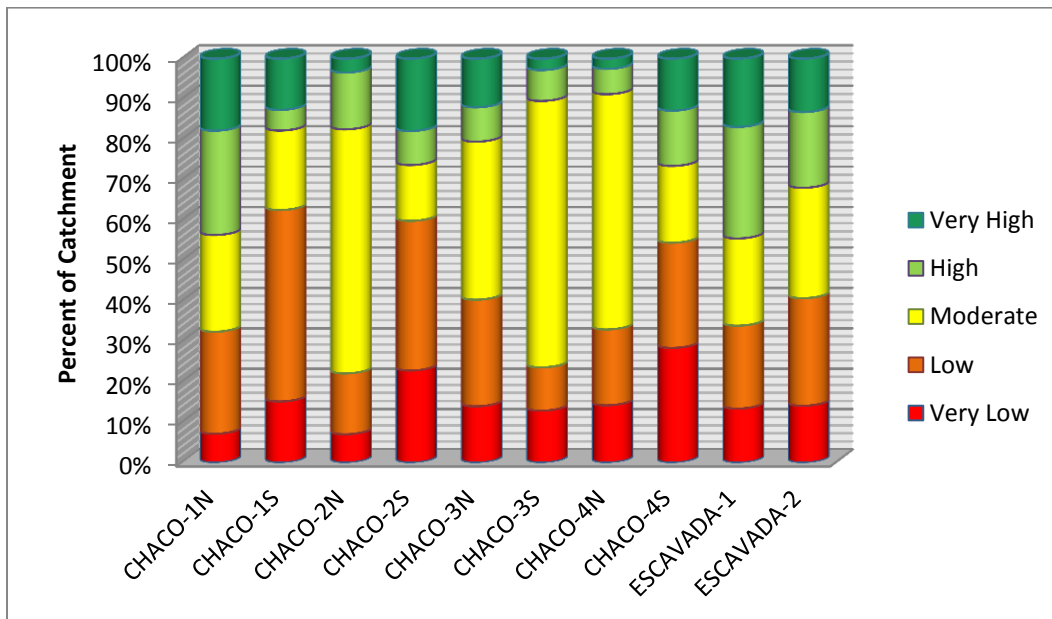

Figure 4-11: Natural Agricultural Suitability by Catchment

Given the large number of classes in this analysis, I present the adjusted residuals in Table 4-6. There are no dramatic trends in these data due to the large numbers of analytical classes and the wide distribution of over- and under-represented categories.

Table 4-6: Observed, Expected, and Adjusted Residuals Derived from Chi Square Analysis of Natural Agricultural Suitability Score by Catchment

Natural Agricultural Suitability		1N	1S	2N	2S	3N	3S	4N	4S
Observed	Very Low	29	52	50	104	82	225	165	253
	Low	103	161	106	169	156	187	217	232
	Moderate	97	67	426	63	230	1151	673	169
	High	105	17	99	39	50	133	72	122
	Very High	72	43	24	82	71	49	29	115
Expected	Very Low	62	52	108	70	90	266	176	136
	Low	86	72	149	97	125	369	245	189
	Moderate	186	155	322	209	269	798	529	407
	High	410	34	71	46	60	177	117	90
	Very High	31	26	54	53	45	135	89	69
Adjusted Residuals	Very Low	-4.17	-0.05	-5.60	4.14	-0.79	-2.50	-0.86	<b>10.07</b>
	Low	1.80	<b>10.48</b>	-3.51	<b>7.39</b>	2.73	<b>-9.48</b>	-1.78	3.12
	Moderate	-6.52	<b>-7.08</b>	5.80	<b>-10.09</b>	-2.35	<b>12.51</b>	6.27	<b>-11.78</b>
	High	<b>-15.08</b>	-2.90	3.28	-1.15	-1.25	-3.28	-4.12	3.35
	Very High	<b>7.34</b>	3.29	-4.09	3.93	3.79	<b>-7.38</b>	-6.34	5.54

By grouping these variables together in logical ways, some more obvious patterns become apparent. Grouping the catchments on the north and south sides of Chaco Wash, and lumping the suitability categories into two more generalized classes: low potential (very low and low) and high potential (moderate, High, Very High), there are significant differences manifested in the resulting matrix ( $X^2=48.81$ ,  $df=1$ ,  $p<.0001$ ; Table 4-7). An examination of the adjusted residuals

shows there is significantly more high potential and less low potential land in the northern catchments, relative to the grouped southern catchments.

Table 4-7: Observed, Expected, and Adjusted Residuals Derived from Chi Square Analysis of Natural Agricultural Suitability Variation by Chaco Wash Catchment Groups

<b>Natural Agricultural Suitability</b>		<b>North Catchments</b>	<b>South Catchments</b>
Observed	Very Low to Low	907	1384
	Moderate to very High	1950	2051
Expected	Very Low to Low	1040	1251
	Moderate to very High	1817	2184
Std. Residuals	Very Low to Low	-4.12	3.75
	Moderate to very High	3.12	2.84

The next analysis compares the two generalized suitability classes in terms of three classes of grouped catchments: north Chaco, south Chaco and Escavada. Once again, differences among these classes are statistically significant, with significantly more suitable lands in the North Chaco and Escavada catchments, and significantly more unsuitable lands in the South Chaco catchment grouping ( $X^2=49.64$ ,  $df=2$ ,  $p<.0001$ ; Table 4-8).

Table 4-8: Observed, Expected, and Adjusted Residuals from Chi Square Analysis of Natural Agricultural Suitability Variation by North, South and Escavada Catchment Groups

<b>Natural Agricultural Suitability</b>		<b>North</b>	<b>South</b>	<b>Escavada</b>
Observed	Very Low to Low	907	1384	621
	Moderate to very High	1950	2051	1122
Expected	Very Low to Low	1035	1245	632
	Moderate to very High	1822	2190	1111
Std. Residuals	Very Low to Low	-3.99	3.94	-0.43
	Moderate to very High	3.01	-2.97	0.32

When the Natural Agricultural Suitability classes are collapsed into the low and high potential categories and compared across the Great House presence/absence catchment classes, significant differences are evident ( $X^2=766.9$ ,  $df=4$ ,  $p<.0001$ ). As shown in Table 4-9, catchments containing Great Houses have significantly more lands characterized as highly suitable and fewer areas classified as low suitability.

Table 4-9: Observed, Expected, and Adjusted Residuals Derived from Chi Square Analysis of Natural Agricultural Suitability Variation across Great House Presence/Absence Catchment Groups

<b>Natural Agricultural Suitability</b>		<b>Great House Present</b>	<b>Great House Absent</b>
Observed	Very Low to Low	1400	891
	Moderate to very High	3137	864
Expected	Very Low to Low	1652	639
	Moderate to Very High	2885	1116
Std. Residuals	Very Low to Low	-6.19	9.95
	Moderate to very High	4.68	-7.53

It is interesting that several Great Houses occur right on the drainage divide between two catchments. These include Alto, New Alto, Peñasco Blanco and Tsin Kletsin. The other five

Great Houses in the Chaco Core all occur within 380 meters of their respective catchment boundaries, which are coincident with the Chaco Wash thalweg.

Holding other factors constant, I suggest that natural agricultural suitability should co-vary with the frequency of archaeologically documented Bonito Phase residential and/or agricultural sites. To test this hypothesis, I extracted Natural Agricultural Suitability scores for each Bonito Phase site meeting these criteria. As summarized in Table 4-10, more than 60% of Bonito Phase Residential and/or agricultural site components occur immediately within zones classified as arable (Moderate, High or Very High). Interestingly, even those sites that occur in lower scoring agricultural zones tend to be very close to arable lands. Based on the calculation of Euclidean Distance to cells classified as arable for each of these site components, the mean is 9.1 m, the maximum is 180 m and the standard deviation is 21 m.

Table 4-10: Bonito Phase Residential/Agricultural Site Frequency Variation across Natural Agricultural Suitability Classes

Natural Agricultural Suitability Class	Bonito Phase Residential and/or Agricultural Site Components	
	Count	Percent of Total
Very Low	24	12.90%
Low	44	23.66%
Moderate	68	36.56%
High	33	17.74%
Very High	17	9.14%

#### 4.4: Arable Lands Cultural Enhancement Feasibility Analysis

The Arable Lands Cultural Enhancement Feasibility Analysis is a suite of hierarchical geoprocessing models that explore the implications of several cultural practices that likely

enhanced the feasibility of successful agricultural production on *potentially arable lands*.

Importantly, potentially arable lands are limited to those portions of the study area that were classified as Moderate, High or Very High in the Natural Agricultural Suitability composite geoprocessing model detailed in the previous section. Geospatial proxies for Pot-watering Feasibility, Nutrient Addition Feasibility and Labor Requirements Feasibility are combined in the Arable Lands Cultural Enhancement Feasibility Analysis Composite Model. Table 4-11 lists the cultural factors employed in this analysis.

Water management is conspicuously absent from this list for the following reasons. Although many of the larger, more formal features representative of these strategies are documented in the archaeological record (e.g. Chetro Ketl fields), there is minimal documentation of the many smaller features potentially distributed throughout the Downtown Chaco area. LiDAR data analysis and results of recent resurveys of areas on Alto Mesa clearly indicates an abundance of agricultural evidence--ranging from check dams to small reservoir features. Given this differential visibility issue, known formal fields, water diversion and storage features were not included in this ancillary study of cultural feasibility.



Table 4-11: Arable Lands Cultural Enhancement Feasibility Analysis Criteria Matrix

<b>Model Weight</b>	<b>Geoprocessing Model Name &amp; Type</b>	<b>Data Categories</b>	<b>Feasibility Score</b>	<b>Input Dataset(s)</b>
33.3%	Pot-watering Feasibility Component	< 300 m from Nearest Potential Water Source	5	UNMCSP and other field surveys; synthetic hydrologic data, NHD Springs;
		300 to 1000 m from Nearest Potential Water Source	4	
		1 to 2 km from Nearest Potential Water Source	3	
		2 to 3 km from Nearest Potential Water Source	2	
		>3 km to Nearest Potential Water Source	1	
33.3%	Nutrient Addition Feasibility Component	High Density Occupational Zones	5	ARMS and UNMCSP Arch. Site data
		Major Side-Canyon Floors	4	
		Middle Zone	3	
		Sandy Mesa Top	2	
33.3%	Field Management Feasibility Component	Very High Feasibility	5	
			3	
		Very Low Feasibility	1	
100%	Arable Lands Cultural Enhancement Feasibility Composite	Very High Feasibility	5	
		High Feasibility	4	
		Moderate Feasibility	3	
		Low Feasibility	2	
		Very Low Feasibility	1	

#### 4.4.1: Pot-Watering Feasibility Component Geoprocessing Model

This variable is a proxy for the relative distance of field locations from reliable water sources. In the absence of geospatial data on the locations of known or likely spring areas, this analysis assumes that any point along the thalweg of the current (or Bonito phase) Chaco Wash, the adjacent Escavada wash and other areas with soils subject to significant accumulation and

potential flooding might have served as a hand-dug well or natural water source. This geoprocessing model generates a Euclidean distance surface from these generalized water sources and then reclassifies that surface into a five class raster in which zones close to probable water sources suitable for pot-watering have high feasibility scores and areas farthest from defined water sources have low feasibility scores. Figure 4-12 shows the raster output from the Pot-Watering Relative Feasibility analysis.

Given the relatively limited range of elevation change within the study area, and the fact that any portion of the study area is less than a day's walk to any other location of the study area, I used a straight "Euclidean" distance function rather than a slope-distance function that considers elevation change in addition to distance as costs. Subsequent refinement of this type of analysis could benefit from a slope-distance approach, particularly in areas with significant terrain variability.

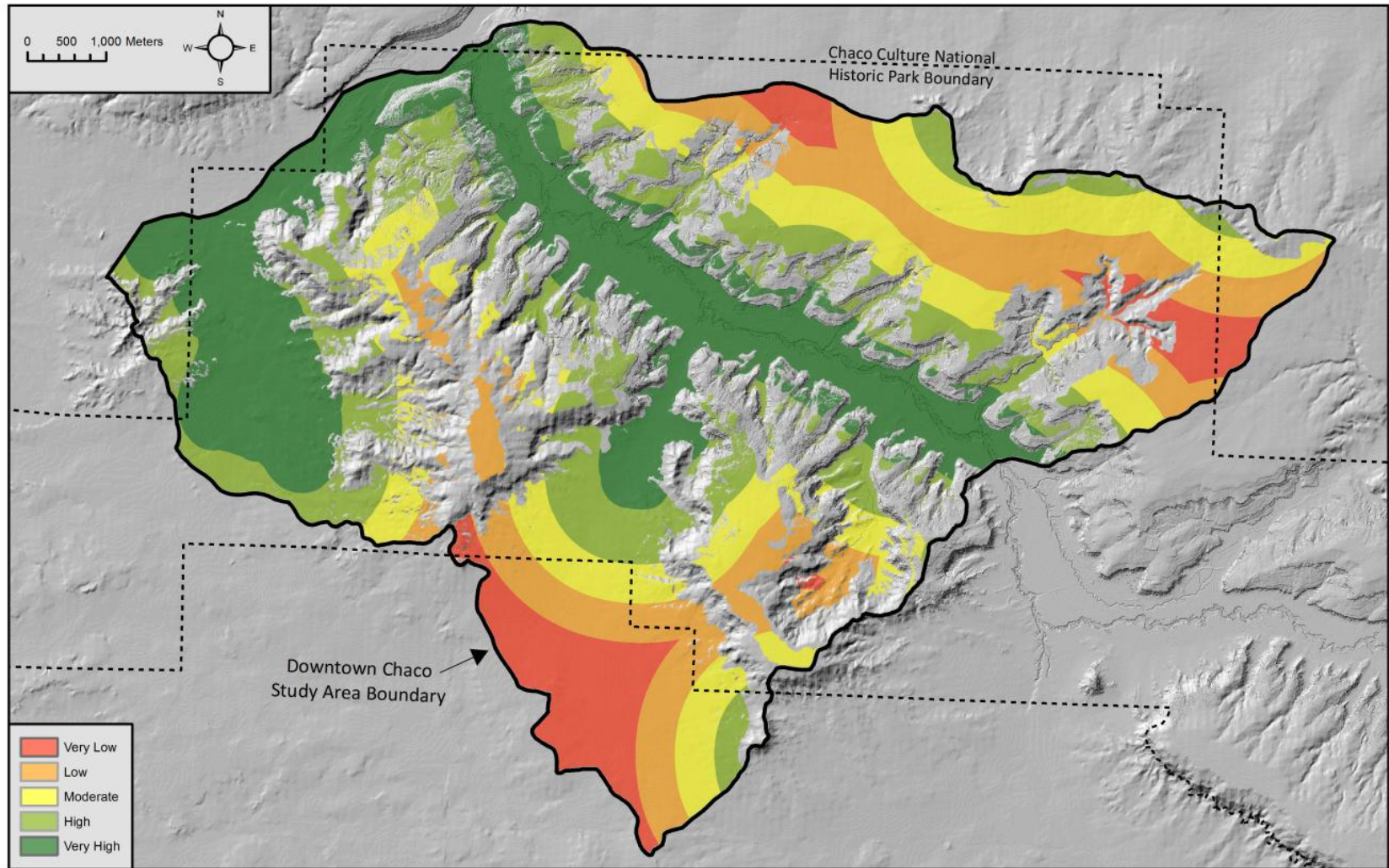

Figure 4-12: Pot-Watering Feasibility Agricultural Suitability Analysis Results

#### **4.4.2: Field Management Feasibility Component Geoprocessing Model**

To provide a general proxy for the spatial distribution of available labor resources during the Bonito Phase, this analysis defines a suitability raster comprised of five classes based on proximity to known Bonito Phase sites with architectural and/or agricultural features. I assume that although many of these sites were probably not populated simultaneously, their relative distribution corresponds to the suitable agricultural areas occurring nearby. A custom query of the NM ARMS database yielded a site sample of potential agricultural sites, which was further refined with data from recent UNMCSP surveys (Wills 2011). As mentioned previously, this is another analysis that might be enhanced through the use of a slope-distance function rather than straight Euclidean Distance. See Table 4-11 for information on the distance thresholds associated with each suitability class. Figure 4-13 presents the results of this analysis.

#### **4.4.3: Nutrient Addition Feasibility Component Geoprocessing Model**

This analysis provides a general geographic measure of the relative difficulty in adding nutrients to field areas. Following ethnographic and archaeological evidence of the importance of adding nutrients ranging from natural humate-rich soils formed in culturally-modified areas to the intentional practice of defecation in field areas (Homburg et. al, 2005, Sandor et al. 2007). The proximity to people is a critical component in the potential for adding nutrients to field areas. For the current study, I generated a surface of continuous distance from centers of dense population (Great Houses), and then parsed that raster into five distance-based classes representing levels of effort to get to potential field areas. Figure 4-14 presents the results of this analysis. Again, despite the relatively

limited constraints imposed by slope within the confines of the study area, a slope-distance function might be warranted to refine this analysis.

#### **4.4.4: Arable Lands Cultural Enhancement Feasibility Composite Geoprocessing Model**

To evaluate the spatial and qualitative importance of all of the cultural factors described in the preceding section, I performed a weighted overlay operation that yielded a single composite raster comprised of five classes of relative agricultural suitability (Figure 4-15). A high resolution graphic showing Figures 4-12 through 4-15 at a larger map scale, side-by-side, is available for download here:

[http://www.earthanalytic.com/DorshowJAS414\\_Poster2.pdf](http://www.earthanalytic.com/DorshowJAS414_Poster2.pdf).

In this case, because there are no obvious reasons to emphasize one cultural factor over another, all factors received the same weight (multiplier) in the map algebra weighted overlay operation. Zones of higher raster values are more "suitable", in this analysis, than lower scoring areas. As such, we might expect a greater density of field in areas than predicted solely by natural factors. Table 4-12 summarizes the total area covered by each of the relative feasibility zones or classes, all of which are still considered viable for agricultural production during the Bonito Phase in the Chaco Core.

Table 4-12: Arable Lands Cultural Enhancement Feasibility Analysis Summary

<b>Feasibility Class</b>	<b>Hectares</b>	<b>Percent of Chaco Core Study Area</b>
Very Low (1)	130.57	2.55%
Low (2)	905.7	17.69%
Moderate (3)	2,205.47	43.08%
High (4)	1,364.41	26.65%
Very High (5)	513.23	10.3%

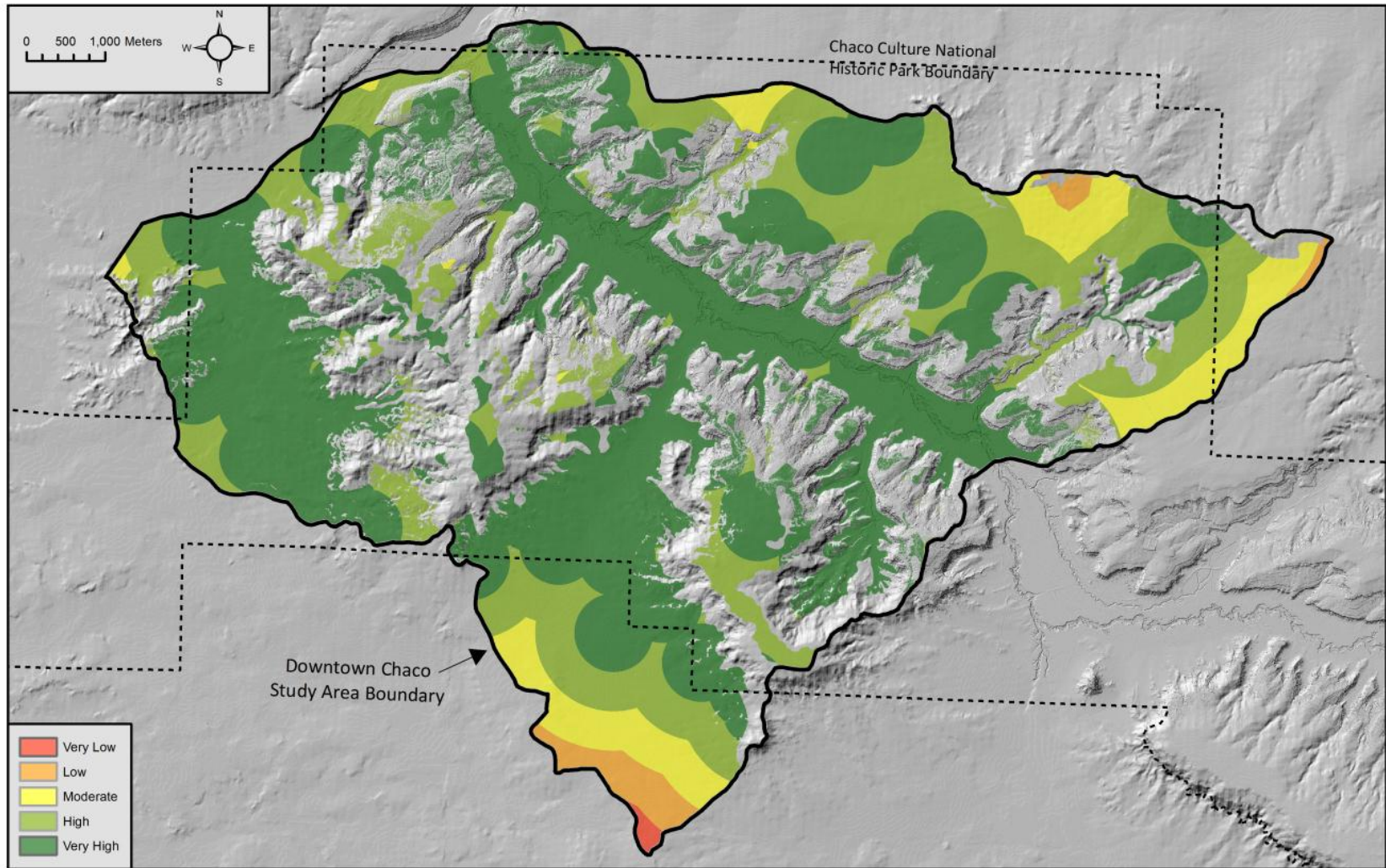

Figure 4-13: Cultural Field Management Feasibility Analysis Results

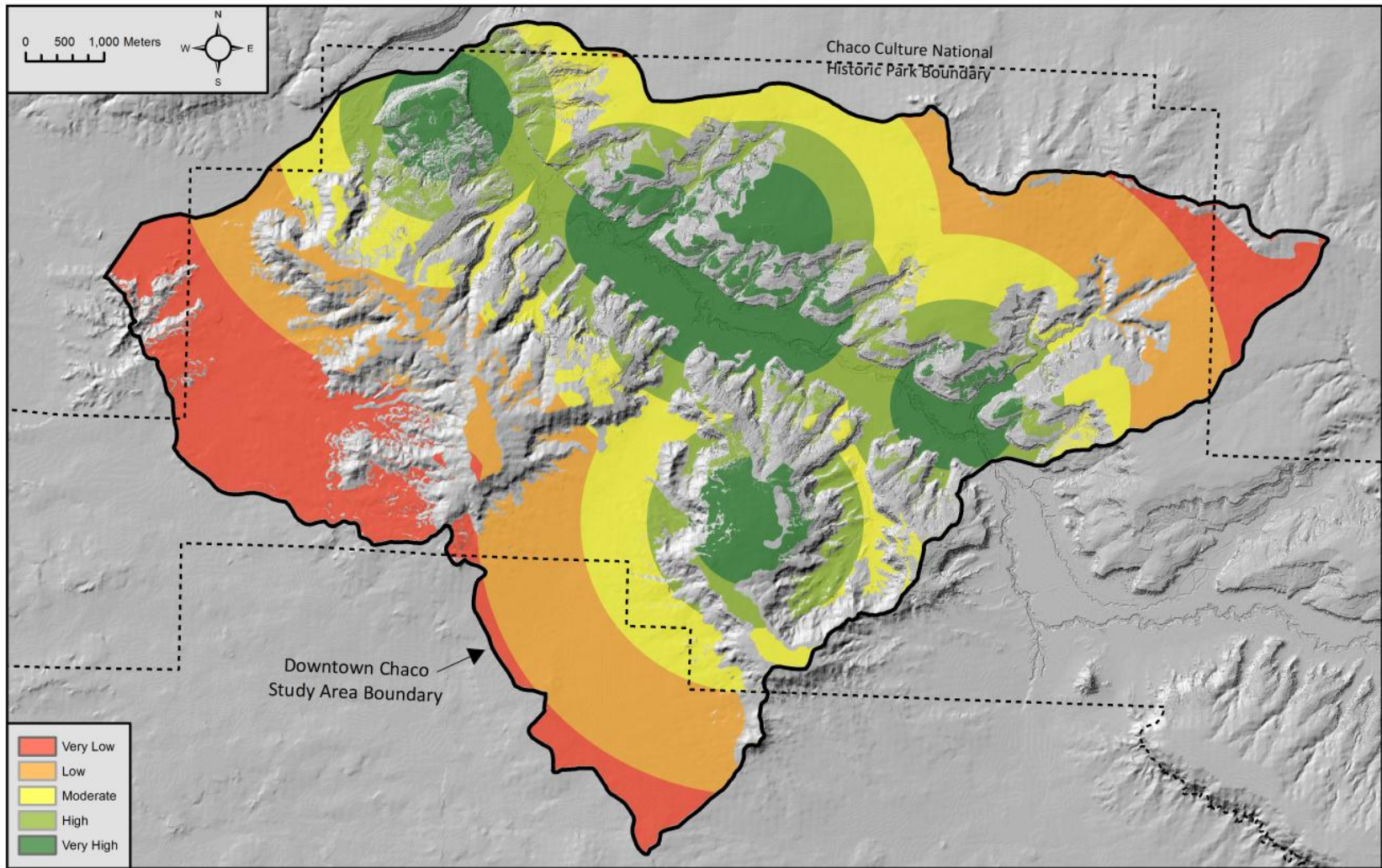

Figure 4-14: Cultural Nutrient Addition Feasibility Analysis Results

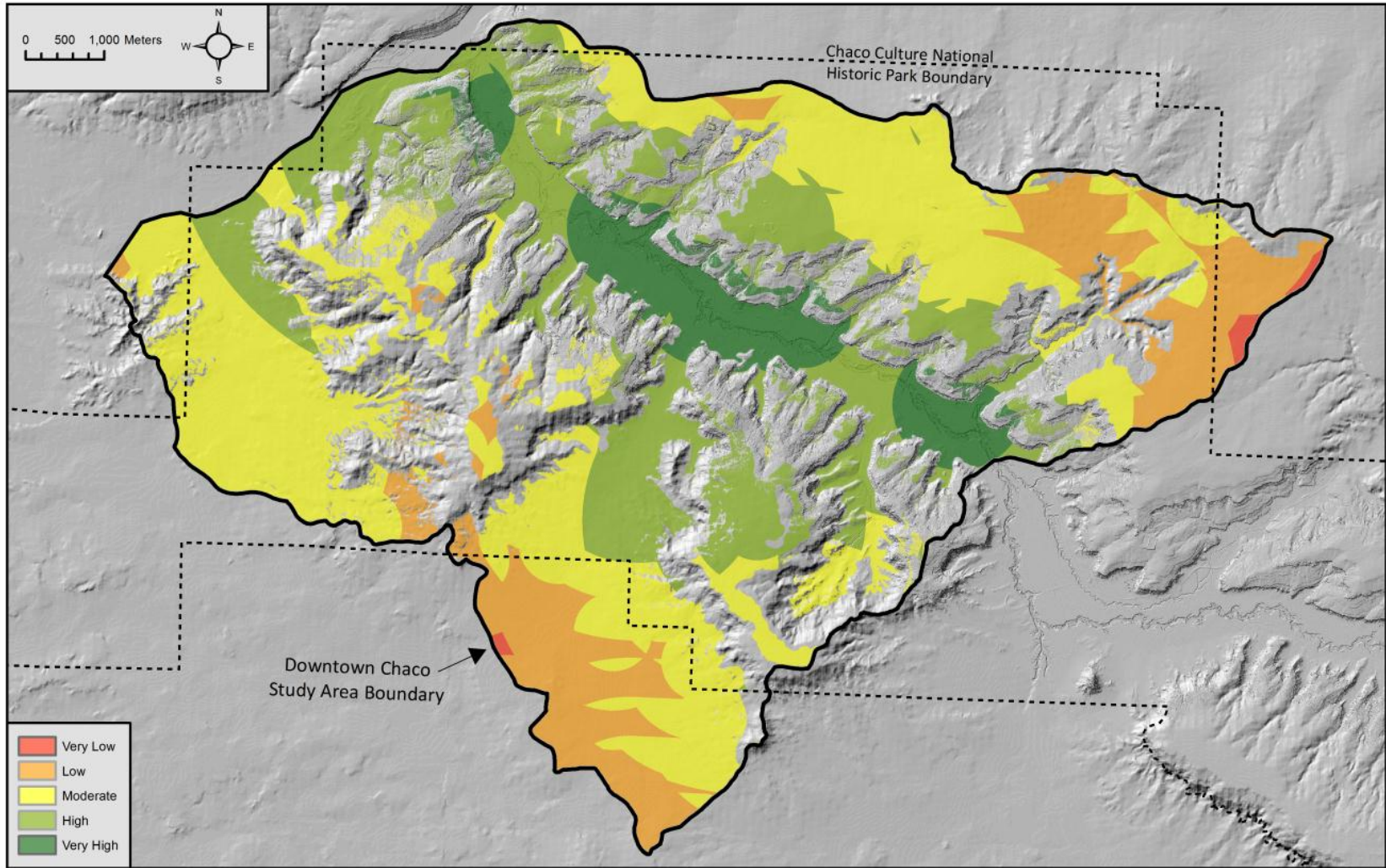

Figure 4-15: Arable Lands Cultural Enhancement Feasibility Composite Analysis Results



#### **4.5: Estimating Maximum Maize Yields from Potentially Arable Lands**

Potential maize yields for identified arable lands can be estimated using the experimental agricultural research of Manolescu (1995) and grain to plant material ratios developed by Ritchie et al. (1992). The analysis sequence is described in the following section

First, I used Map Algebra functions to select and extract pixels classified as potentially arable lands (i.e. belonging to the Moderate, High and Very High suitability classes) from the Natural Agricultural Geoprocessing Model output suitability raster. Using this extracted dataset as input, I employed the ArcGIS RegionGroup function to aggregate and classify contiguous zones of arable lands. Next, I applied an ArcGIS Majority Filter to the RegionGroup output in order to remove noise: isolated patches of potentially arable land measuring less than 100 m<sup>2</sup>. Following the methods of Manolescu (1995, Table 7), I then calculated the number of clumps per hectare to be approximately 686 (2.7 m spacing between alternating planted and fallow patches) and corresponding yield to be about 0.2 kg per clump. Using these estimates, I then multiplied the total area (in hectares) of each unique contiguous zone by the number of kilograms per hectare of maximum yield. Finally, I classified the output raster into zones of total maximum yield. Figure 4-16 shows the results of this analysis.

This analysis results in a maximum yield of about 123,520 kilograms of maize. In other words, with sufficient water inputs to ensure 100 percent success of crops planted on no less than 50% of the roughly 900 hectares of arable lands in the Chaco 3N and 4N catchments, as much as 123,520 kg of maize might have been produced in a given season. If we assume that only 50% of the areas within the "arable lands" zones were planted (using the spacing and alternation described above) and only 50% of the planted

plots yielded harvestable crops, the total comes to 30,088 kg of maize. For comparison, 2000 Hopi cultivated less than 1000 hectares in the late 19<sup>th</sup> century or about 316 kg of cornmeal per person annually (Bradfield 1971).

#### **4.6: Estimating Water Availability for Potentially Arable Lands**

Another way to geospatially model agricultural potential during the Bonito Phase is to consider not only direct precipitation on fields, but also water derived from sheetwash and channelized surface flows. Estimated yields for maize that incorporate surface runoff were generated by multiplying the total area upstream of each drainage point by an estimate for average rainfall to generate a total volume of water entering and running through the Chaco core catchments. For this preliminary estimate of precipitation, I did not consider specific precipitation estimates for the Bonito phase but rather used an annual average of 22.19 cm (8.74 inches), drawing on climate summary data for the period between 1912 and 2004 as reported by the Utah Climate Center website (<http://climate.usu.edu>). This precipitation volume estimate is then multiplied by a rainfall-runoff factor that varies for each of the two scenarios listed in Table 4-13.

This analysis generates two scenarios of “sufficient water”, evaluating geospatial proxies for predicted water availability during the Bonito Phase. These are described in the following sections.



Table 4-13: Sufficient Water Scenario Analysis

Max Yields*		Scenario1 (Conservative)		Scenario 2 (Moderate)	
Point ID	Upstream Drainage Area (ha)	Max Maize Yield (kg)	Weighted Potential Max Maize Yield (kg)	Max Maize Yield (kg)	Weighted Potential Maize Yield (kg)
CWN3.10	10	777.6	38.9	5,183.7	259.2
CWN3.13	13	1,010.8	50.5	6,738.8	336.9
CWN3.16	16	1,244.1	62.2	8,294.0	414.7
CWN3.17	17	1,321.8	66.1	8,812.3	440.6
CWN3.32	32	2,488.2	124.4	16,587.9	829.4
CWN3.100	100	7,775.6	388.8	51,837.2	2,591.9
CWN3.200	200	15,551.2	777.6	103,674.5	5,183.7
CWN3.300	300	23,326.8	1,166.3	155,511.7	7,775.6
CWN3.400	400	31,102.3	1,555.1	207,349.0	10,367.4
CWN3.500	500	38,877.9	1,943.9	259,186.2	12,959.3
CWN3.600	600	46,653.5	2,332.7	311,023.4	15,551.2
CWN3.652	652	50,696.8	2,534.8	337,978.8	16,898.9
CWN4.5	5	388.8	19.4	2,591.9	129.6
CWN4.6	6	466.5	23.3	3,110.2	155.5
CWN4.7	7	544.3	27.2	3,628.6	181.4
CWN4.15	15	1,166.3	58.3	7,775.6	388.8
CWN4.18	18	1,399.6	70.0	9,330.7	466.5
CWN4.21	21	1,632.9	81.6	10,885.8	544.3
CWN4.24	24	1,866.1	93.3	12,440.9	622.0
CWN4.34	34	2,643.7	132.2	17,624.7	881.2
CWN4.36	36	2,799.2	140.0	18,661.4	933.1
CWN4.100	100	7,775.6	388.8	51,837.2	2,591.9
CWN4.104	104	8,086.6	404.3	53,910.7	2,695.5
CWN4.110	110	8,553.1	427.7	57,021.0	2,851.0
CWN4.184	184	14,307.1	715.4	95,380.5	4,769.0
CWN5.10	10	777.6	38.9	5,183.7	259.2
CWN5.46	46	3,576.8	178.8	23,845.1	1,192.3
CWN5.51	51	3,965.5	198.3	26,437.0	1,321.8
CWN5.56	56	4,354.3	217.7	29,028.9	1,451.4
CWN5.100	100	7,775.6	388.8	51,837.2	2,591.9
CWN5.162	162	12,596.4	629.8	83,976.3	4,198.8
CWN5.171	171	13,296.3	664.8	88,641.7	4,432.1

\*Based solely on Water Requirements and Water Availability at Specific Pour Points

#### **4.6.1: Sufficient Water Scenario 1**

Sufficient Water Scenario 1 uses a rainfall-runoff ratio value of 0.03 suggested for the Chetro Ketl field complex by Benson (2006:300). Using this factor, which assumes a 97% loss of all water hitting the surface, the reduced raw precipitation volumes are then multiplied by a value of 0.87 m, which is an estimate for the minimum water requirements for a yield of one kilogram of maize using traditional Hopi farming methods as presented by Dominguez and Kolm (2005). Finally, this estimate of maximum yield is further reduced by an additional multiplier of 0.05 to cover other less tractable factors related to agricultural productive potential such as failure due to pests, catastrophic flooding, disease, insufficient field area availability, poor field location selection, inadequate planting coverage, and others. In other words, all of these generalized risks are arbitrarily combined in weighting factors that reduce the maximum potential yield by an additional 95%.

#### **4.6.2: Sufficient Water Scenario 2**

Sufficient Water Scenario 2 is based on the same series of calculations using all of the same values with the exception of the rainfall to runoff ratio. The work of Manolescu (1995), Dominguez and Kolm (1995) suggests only 80% loss of water to bare soil evaporation under ideal soil texture conditions in level field areas. While bare soil evaporation is only a component of the rainfall-runoff ratio presented by Benson (2006:300), it is not unreasonable to assume that, under the best conditions in areas receiving sufficient direct precipitation and at least some run-on, nearly 20% of the water hitting the surface is available to planted maize crops. As such, the weighted yield

estimates listed for Scenario 2 use a water loss factor of .2 rather than the .03 used in Scenario 1.

The two water availability scenarios can be thought of as very preliminary proxies for comparing widely variable runoff conditions and other factors controlling agricultural productivity. They do not take into account the spatial distribution of potentially arable lands, plant-spacing, pot-watering, and many other factors explored in this paper.

#### **4.7: Conclusions**

The results of this analysis strongly suggest that a significant amount of potentially arable land occurs within the Chaco Core during the Bonito Phase. The results presented here are relevant to ongoing debates about the nature of society and nature in Chaco, particularly arguments that the canyon could not have produced enough agricultural yields to sustain estimated residential populations (Benson et al. 2006; Benson 2011). However, the purpose of this study is not to evaluate these competing claims about socioeconomic relationships but rather to develop and apply an independent, replicable, and quantitative geospatial framework for estimating agricultural potential using geospatially-enabled environmental data based on well-known, ethnographic observations about the environmental constraints of subsistence agriculture in the American Southwest (see Hack 1942; Bradfield 1971; Sandor et al. 2007) and archaeologically documented prehistoric field systems (Vivian 1974; Maxwell and Anschuetz 1992; Damp et al. 2002).

Nonetheless, it is worth pointing out that this effort has generated potential yield values for Chaco Canyon that exceed previous estimates based on acreage derived wholly from

known or hypothesized field locations along the floor of the canyon (see Vivian 1972, 1974; Benson et al. 2006; Benson 2011). There are two reasons for this. First, my analysis is based on a much larger amount of arable land, derived from ethnographic guides to cultivation potential rather than exclusively from the size of inferred archaeological field systems. Second, my study emphasizes water and soil texture, rather than the soil chemistry of putative field locations. I am not suggesting that previous estimates are incorrect, but my model assumes that Chaco farmers employed a variety of farming techniques and risk reduction strategies (such as field dispersal) beyond formal gridded and irrigated field systems. Obviously because my approach concludes that the canyon was potentially more productive than previous studies, it implies that those studies underestimate the complexity of Chacoan food production, but the different approaches cannot be directly compared because the underlying initial assumptions are not the same. Hopefully the study presented here will allow for such direct comparison. For example, my ongoing research integrates paleoclimate data to create a more refined water-loss raster analysis based on evapotranspiration, runoff, vegetation and other factors (which might eventually include published soil chemistry data) to further refine yield estimates during the Bonito Phase.

## CHAPTER 5 - CONCLUSIONS

The studies presented in Chapters 2-4 clearly demonstrate the value of designing and applying multi-criteria geospatial models to both conservation and research questions involving archaeological data. This chapter begins with a summary of each case-study, with a focus on project history, research and conservation impacts, and other contextual information. The document concludes with a discussion of the key themes that bind these studies into a collective work.

### 5.1: Galisteo Basin

Chapter 2 presents a summary of the GIS methods and results of the Green Infrastructure Plan outlined in the Galisteo Basin Conservation Initiative final report (Jansens et al., 2011). The Galisteo Watershed Conservation Initiative GIS analysis focused on four primary conservation criteria: cultural resources, habitat, water, and scenery. Drawing on input and guidance from the multi-disciplinary, multi-agency steering committee as well as the results of expert review and feedback sessions held on each of the criteria categories, I designed and compiled the multi-criteria suitability weighted overlay analysis described in the following list:

- Cultural Resources Conservation Value
  - Recorded archaeological and historical sites considered eligible or potentially eligible to National Register of Historic Places
  - Sites on or nominated to the National Register of Historic Places or the New Mexico State Register of Cultural Properties
  - Galisteo Archaeological Protection Act Sites
- Habitat Conservation Value
  - Animal species diversity
  - Piñon-juniper woodlands



- Grasslands
- Forests
- Areas near semi-permanent water
- Wetland and riparian zones
- Water Conservation Value
  - Drainage buffers
  - Water bodies
  - Wetland and riparian zones
  - Spring buffers
  - Aquifer recharge zones
- Scenic Conservation Value
  - Scenic grasslands
  - Scenic riparian areas
  - Scenic landmarks
  - Scenic piñon-juniper woodlands

Although it is emphasized elsewhere in the final GWCI report (Jansens et al. 2011), the methods and results presented in Chapter 2 do not provide much detail on the importance of each of the sub-criteria. Given the focus of this dissertation, some elaboration on the cultural resources component of the study is warranted.

The Galisteo Basin is an incredibly important cultural and historical locality with significant development pressures. In 2004, the Galisteo Basin Archaeological Sites Protection Act was signed into New Mexico state law ([Public Law 108-208-Mar. 19, 2004](#)). The following is an excerpt from the written law (Sec. 2. Findings and Purpose):

(a) FINDINGS.—The Congress finds that—

- (1) the Galisteo Basin and surrounding area of New Mexico is the location of many well preserved prehistoric and historic archaeological resources of Native American and Spanish colonial cultures;
- (2) these resources include the largest ruins of Pueblo Indian settlements in the United States, spectacular examples of Native American rock art, and ruins of Spanish colonial settlements; and
- (3) these resources are being threatened by natural causes, urban development, vandalism, and uncontrolled excavations.

(b) PURPOSE.—The purpose of this Act is to provide for the preservation, protection, and interpretation of the nationally significant archaeological resources in the Galisteo Basin in New Mexico.

The 24 sites assigned protection under this law were assigned special importance in the cultural resources conservation weighted overlay analysis. Large buffer zones placed around these and other sites nominated to the National Register of Historic Places received an effective weight of 2 in the model, which is twice the value of recorded sites that have been recognized as eligible or potentially eligible to the National Register by the New Mexico SHPO.

The conservation prioritization analysis summarized in Chapter 2 provided a strong foundation for the larger emphasis of the Galisteo Watershed Conservation Initiative: defining and protecting “Green Infrastructure” in the Galisteo Basin and beyond (Jansens et al. 2011). The Green Infrastructure Planning movement advocates a balanced approach to conservation and real estate development, which is increasingly rare in these politically polarized times, particularly in the United States.

As described by McDonald and colleagues,

“One of the factors that distinguishes green infrastructure plans from other conservation plans is that the primary objective is to identify suitable lands for conservation in the context of current and future developed lands. Green infrastructure planning can assist the traditional land use planning process, delineating lands for protection before the allocation of lands for new development. This not only ensures that important natural systems are not fragmented by urbanization, but it also provides a framework for locating new development” (2005:22).

The extra emphasis on Galisteo APA sites reflected in the GIS analysis is inherent to the GWCI Green Infrastructure Plan, which seeks not only to *identify* important resources for conservation, but also to seek realistic opportunities for public-private arrangements with a strong potential for success. As presented in section 6 of the law, “The Secretary is authorized to enter into cooperative agreements with owners of non-Federal lands with regard to an archaeological protection site, or portion thereof, located on their property.” The balance between conservation goals, development pressure, and political reality are truly manifested in this project, and cultural resources play a major role.

I suggest that the water and habitat composite suitability composite suitability surfaces indirectly delineate zones of relative archaeological and historic potential. Not surprisingly, people have always tended to frequent localities with abundant resources to meet their basic subsistence requirements. This is another instance where collaborative multi-criteria modeling for one purpose (natural resource conservation) can provide important guidance for other purposes (cultural resources protection from development).

As we stress in the GWCI final report (Jansens et al, 2011), the conservation criteria we defined and the results that were obtained from the subsequent analysis provide a

reasonable starting point for prioritizing conservation within the Galisteo Basin. The analytical framework was deliberately architected to allow non-GIS users to re-run the analysis using updated data and modified geoprocessing models, thereby supporting the ongoing evolution of the GWCI Green Infrastructure Plan.

## **5.2: Vermont**

The article and user manual presented in Chapter 3 document presents an overview of the collaborative effort to geospatially enable portions of the cultural resources assessment and review process in Vermont, sponsored by the Vermont Division for Historic Preservation and the Vermont Agency of Transportation. The primary goal of the project was develop and implement a GIS analysis framework for modeling the environmental criteria identified in the Environmental Predictive Model for Location Archeological Sites, an official state form required by DHP and

VTrans for cultural resources assessment and review (

\*\*\* Environmental Predictive Model For Locating Archaeological Sites \*\*\*

Project: Barnet-Manroe VT/NH <sup>BHO</sup> 1447(23) Design Plans: Pre Construction  
 USGS: \_\_\_\_\_ Date: 5/15/96 Staff: Wilkie March 96

Environmental Variable	Proximity	Value	Assigned Score
1) Distance to Existing or Relict River or Permanent Stream <i>Connecticut River</i>	0-60 m	12	<u>12</u>
	60-120 m	8	
	120-180 m	4	
2) Distance to Pond or Lake	0-60 m	12	<u>0</u>
	60-120 m	8	
	120-180 m	4	
3) Distance to Intermittent Stream <i>up river</i>	0-60 m	8	<u>4</u>
	60-120 m	4	
	120-180 m	2	
4) Distance to Wetland (wetlands > one acre in size)	0-60 m	8	—
	60-120 m	4	
	120-180 m	2	
5) Confluence of River/River or River/Brook <i>down river</i>	0-60 m	12	<u>8</u>
	60-120 m	8	
	120-180 m	4	
6) Confluence of Intermittent Streams	0-60 m	8	<u>0</u>
	60-120 m	4	
	120-180 m	2	
7) Falls or Rapids	0-60 m	8	<u>0</u>
	60-120 m	4	
	120-180 m	2	
8) Restricted Access/ Drainage divides	0-60 m	8	<u>0</u>
	60-120 m	4	
9) Head of Draw	0-60 m	8	<u>0</u>
10) Isolated Spring	0-60 m	8	<u>0</u>
	60-120 m	4	
11) Major Floodplain/Alluvial Terrace	0-60 m	8	—
	60-120 m	4	
12) <u>Lithic Outcrop (Both sides of River)</u>	0-180 m	20	<u>20</u>
13) Knoll Top/Ridge Crest/Promontory	0-60 m	8	<u>0</u>
14) Kame/Outwash Terrace (valley edge features)	0-60 m	8	<u>0</u>
15) Other Major Topographic Break	0-60 m	8	<u>0</u>
16) Relict Beach or Shore Line	0-60 m	12	<u>0</u>
17) Caves/Rockshelters	0-60 m	12	<u>0</u>
18) Excessive Slope (>15%) or Steep Erosional Slope (>20%)		-8	—
19) Very Poorly Drained Soils		-8	—
20) Excessively Disturbed		-24	—
Total Score:			<u>44</u>

20+ = Archaeologically Sensitive      0-18 = Archaeologically Non-sensitive

Figure 5-1). The secondary goal was to generate a statewide map of archaeological potential (or sensitivity) that might guide smart land-use planning and development practices.

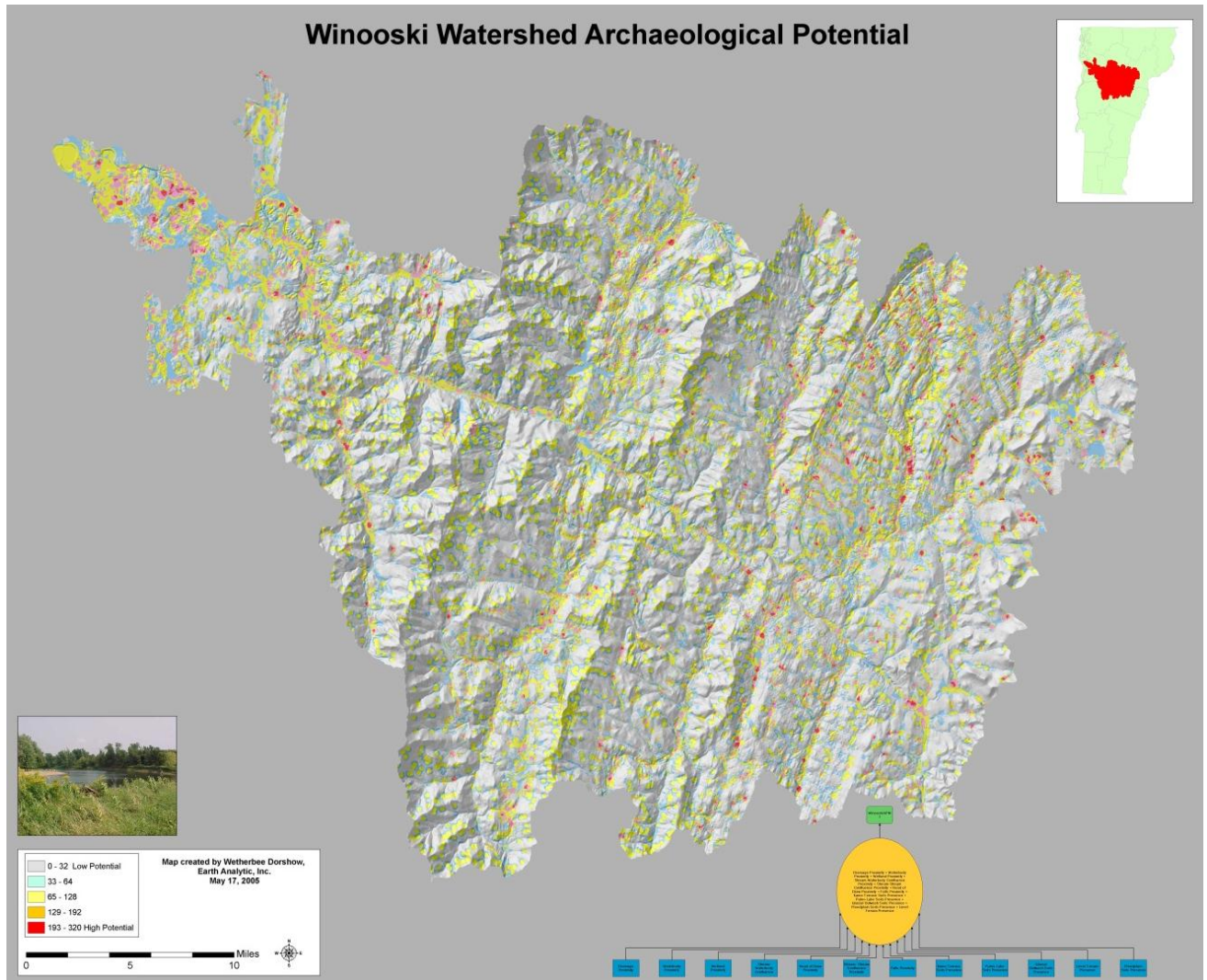

Figure 5-2 shows a snapshot of the analysis results for one of Vermont’s most archaeologically significant watersheds.

I served as lead technical architect for the project team, which was supported by a steering committee that helped define the analysis criteria and plan how the resulting data and tools should be used for the support of cultural resources protection in Vermont. Given the complexity of the problem of determining and legislating subsurface archaeological potential, the entire project team settled on a couple of key points for

inclusion in training and educational materials and presentations. These are summarized below.

- The analysis results are intended to offer preliminary, relatively coarse information about the Native American habitability of any given 10 meter area of Vermont but it is not a relative "sensitivity map." For example, an area that scores 6 layers is not necessarily more archaeologically sensitive than an area that scores 1 layer.
- Users of the data and maps are encouraged to look at environmental and cultural characteristics of "neighborhoods," rather than intensely focusing on any one 10 meter, or 1000, meter, area.
- The analysis results do not reflect information about possible locations of Native American burials and cemeteries, stone quarry sites, caves and rock shelters, religious sites, trails, and other kinds of special purpose sites that represent complex human behavior over the 12,000 year span.
- The environmental layers ... are not intended to help locate historic period archaeological sites.
- Most tests of the environmental predictive model (whether based on the original paper checklist form or the VTASM map results) are tautological due to biased sampling strategies embedded in the long-standing state policy. Basically, the model has been used to prioritize archaeological investigation in specific environmental contexts, so the relative paucity of recorded sites in other contexts cannot be used to support the predictive potential of the model.

=== Environmental Predictive Model For Locating Archaeological Sites ===

Project Barnet-Manroe VT/NH GHO 1447(23) Design Plans Pre-Completed March 96  
 USGS Date 5/15/96 Staff Wilkie

Environmental Variable	Proximity	Value	Assigned Score
1) Distance to Existing or Relict River or Permanent Stream <i>Connecticut River</i>	0-60 m	12	<u>12</u>
	60-120 m	8	
	120-180 m	4	
2) Distance to Pond or Lake	0-60 m	12	<u>0</u>
	60-120 m	8	
	120-180 m	4	
3) Distance to Intermittent Stream <i>up river</i>	0-60 m	8	<u>4</u>
	60-120 m	4	
	120-180 m	2	
4) Distance to Wetland (wetlands > one acre in size)	0-60 m	8	<u>—</u>
	60-120 m	4	
	120-180 m	2	
5) Confluence of River/River or River/Brook <i>down river</i>	0-60 m	12	<u>8</u>
	60-120 m	8	
	120-180 m	4	
6) Confluence of Intermittent Streams	0-60 m	8	<u>0</u>
	60-120 m	4	
	120-180 m	2	
7) Falls or Rapids	0-60 m	8	<u>0</u>
	60-120 m	4	
	120-180 m	2	
8) Restricted Access/ Drainage divides	0-60 m	8	<u>0</u>
	60-120 m	4	
9) Head of Draw	0-60 m	8	<u>0</u>
10) Isolated Spring	0-60 m	8	<u>0</u>
	60-120 m	4	
11) Major Floodplain/Alluvial Terrace	0-60 m	8	<u>—</u>
	60-120 m	4	
12) <u>Lithic Outcrop (Both sides of River)</u>	0-180 m	20	<u>20*</u>
13) Knoll Top/Ridge Crest/Promontory	0-60 m	8	<u>0</u>
14) Kame/Outwash Terrace (valley edge features)	0-60 m	8	<u>0</u>
15) Other Major Topographic Break	0-60 m	8	<u>0</u>
16) Relict Beach or Shore Line	0-60 m	12	<u>0</u>
17) Caves/Rockshelters	0-60 m	12	<u>0</u>
18) Excessive Slope (>15%) or Steep Erosional Slope (>20%)		-8	<u>—</u>
19) Very Poorly Drained Soils		-8	<u>—</u>
20) Excessively Disturbed		-24	<u>—</u>
Total Score:			<u>44</u>

20+ = Archaeologically Sensitive      0-18 = Archaeologically Non-sensitive

Figure 5-1: Vermont Environmental Predictive Model Form



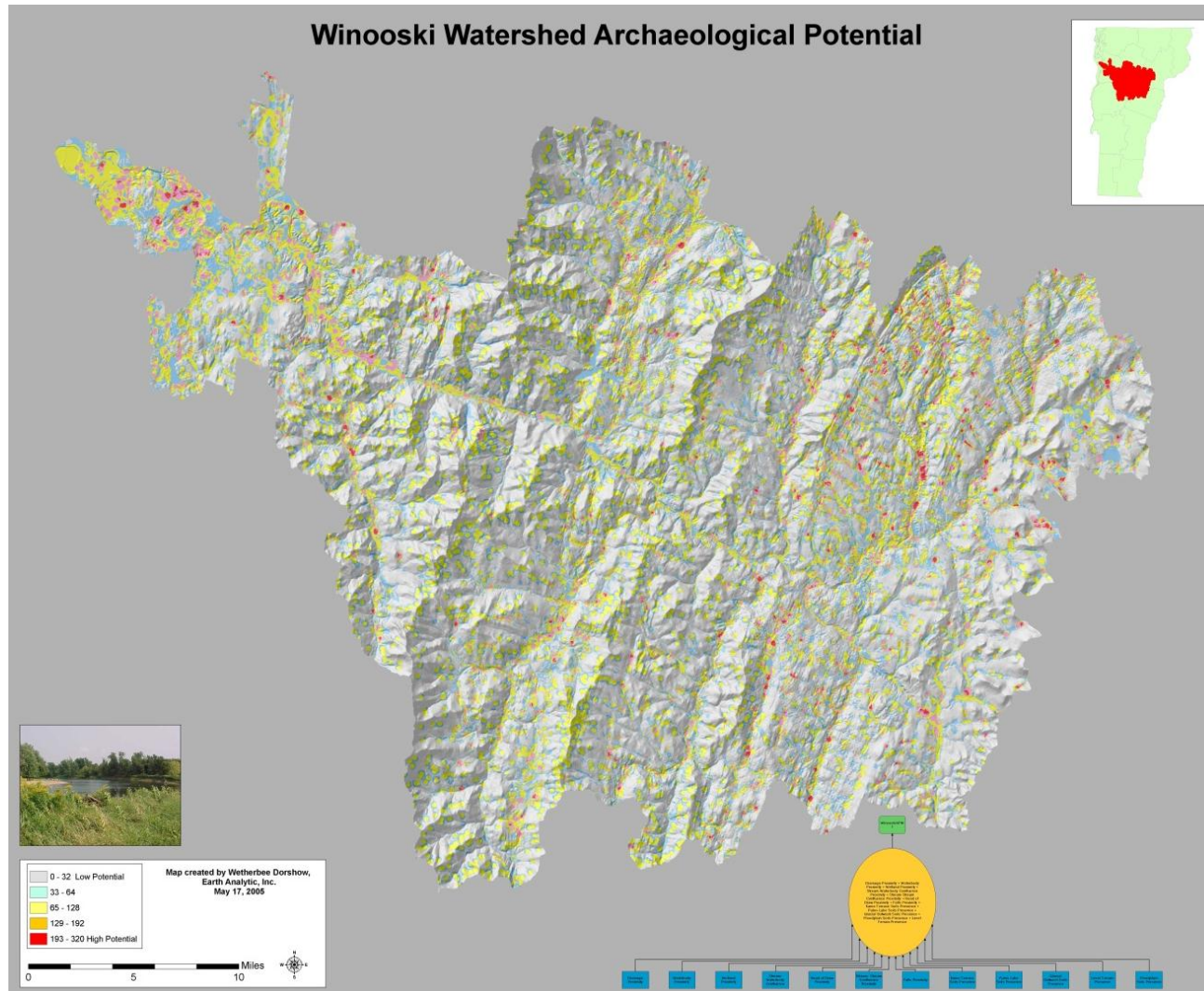

Figure 5-2: Vermont Archaeological Sensitivity Analysis, Winooski Watershed

Despite these caveats, the approach and the results are valuable tools in the effort to support cultural resources management efforts in Vermont. Since early 2007, every “Vermont Archaeological Resource Assessment” (ARA or Phase 1a Survey) report submitted to the Vermont Division for Historic Preservation (DHP) for Section 106 review has been required to reference the VTASM analysis results (maps) within the associated project area (personal communication, Dr. John Crock, University of Vermont Consulting Archaeology Program, February, 2012).

The VTASM tools and data are distributed by DHP to state personnel and authorized archaeological consulting firms and researchers operating in Vermont through both desktop GIS and web applications. The VTASM desktop GIS deliverable is a DVD containing the following: ArcGIS-ready geoprocessing tools, an ArcMap document, GIS data (inputs and results), and the user manual (see Chapter 3). I helped DHP design and implement several interactive web applications that include the sensitivity analysis results. Although the public-access version of the site is not yet live as of this writing, two internal applications are used on a regular basis by internal DHP and VTrans staff, and authorized consultants, respectively.

Figure 5-3 shows a screenshot of the internal DHP site, which includes site location, ARA review project boundaries, and a variety of important contextual information ranging from historic topographic maps and imagery to soils and other geological data.

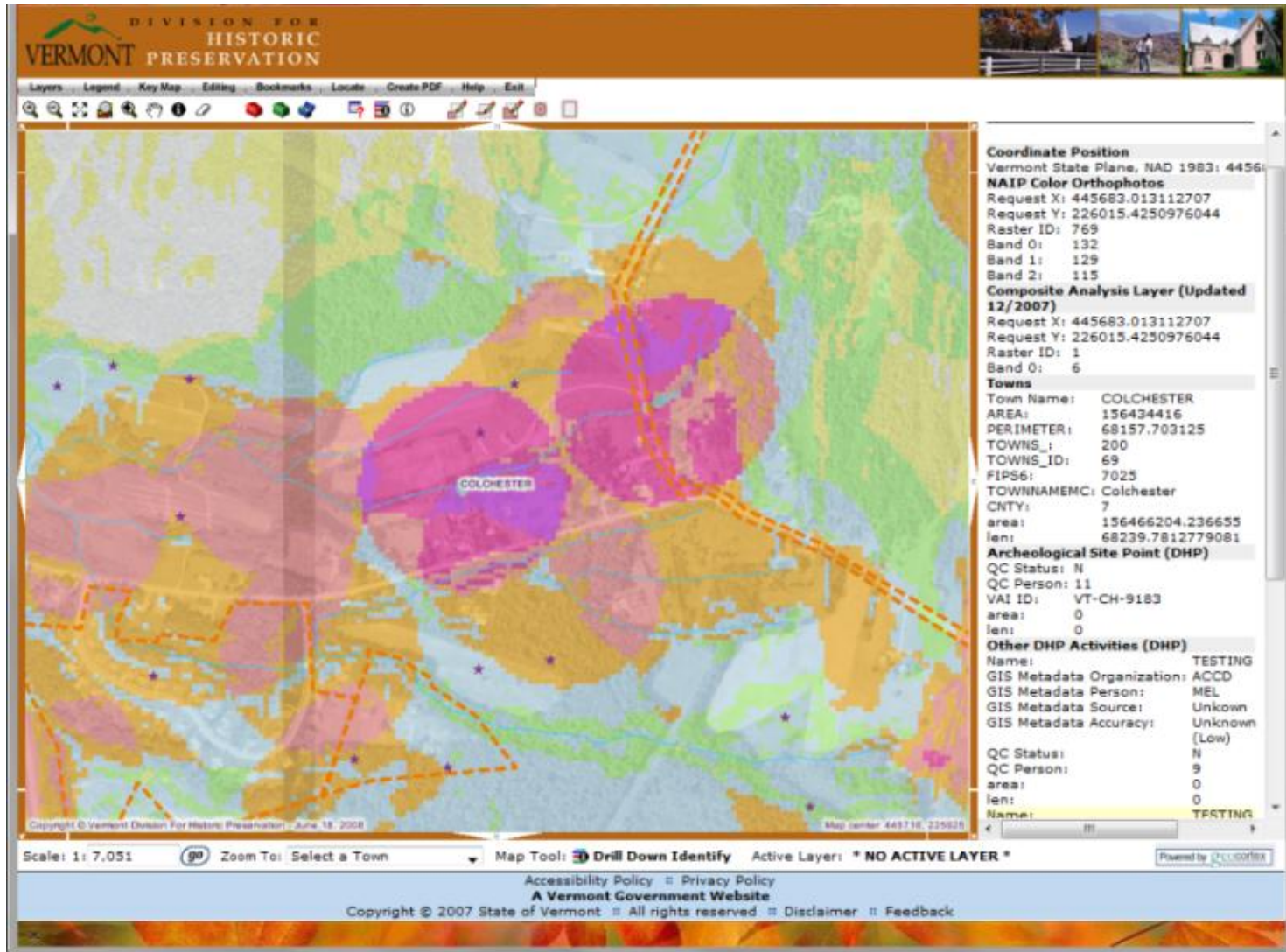

Figure 5-3: Screenshot of the DHP ArcheoMap Application.

### **5.3: Chaco Canyon**

The Chaco Natural Agricultural Potential analysis is the first of its kind applied to Chaco Canyon. This study is a predictive geospatial model of relative agricultural potential in the Chaco Core during the Bonito Phase (A.D. 850 to 1140), a period of rapid sociocultural evolution on the Colorado Plateau. The results of this analysis suggest that previous models of Chacoan agricultural productivity have underestimated local production capacity. Previous studies have focused solely on floodplain contexts, whereas this study points to a more comprehensive and geographically distributed use of the landscape. The subsequent analysis of the Alto Mesa Community presented in Wills and Dorshow (2012) builds on this theme through the detailed assessment of the Natural Agricultural Model within the Alto Mesa catchment. Clearly, this study paves the way for a much broader scale study of agricultural potential throughout the San Juan Basin and beyond. I am currently working on a paper with other UNM researchers to examine agricultural potential for the larger region, drawing on a custom sample of archaeological site and survey data from the Museum of New Mexico's ARMS database. Figure 5-4 shows the distribution of recorded sites with probable agricultural components dated between AD 840 and 1200. By extending the agricultural suitability model to cover this larger region, we can evaluate the implications of the notable settlement gaps shown within this figure.

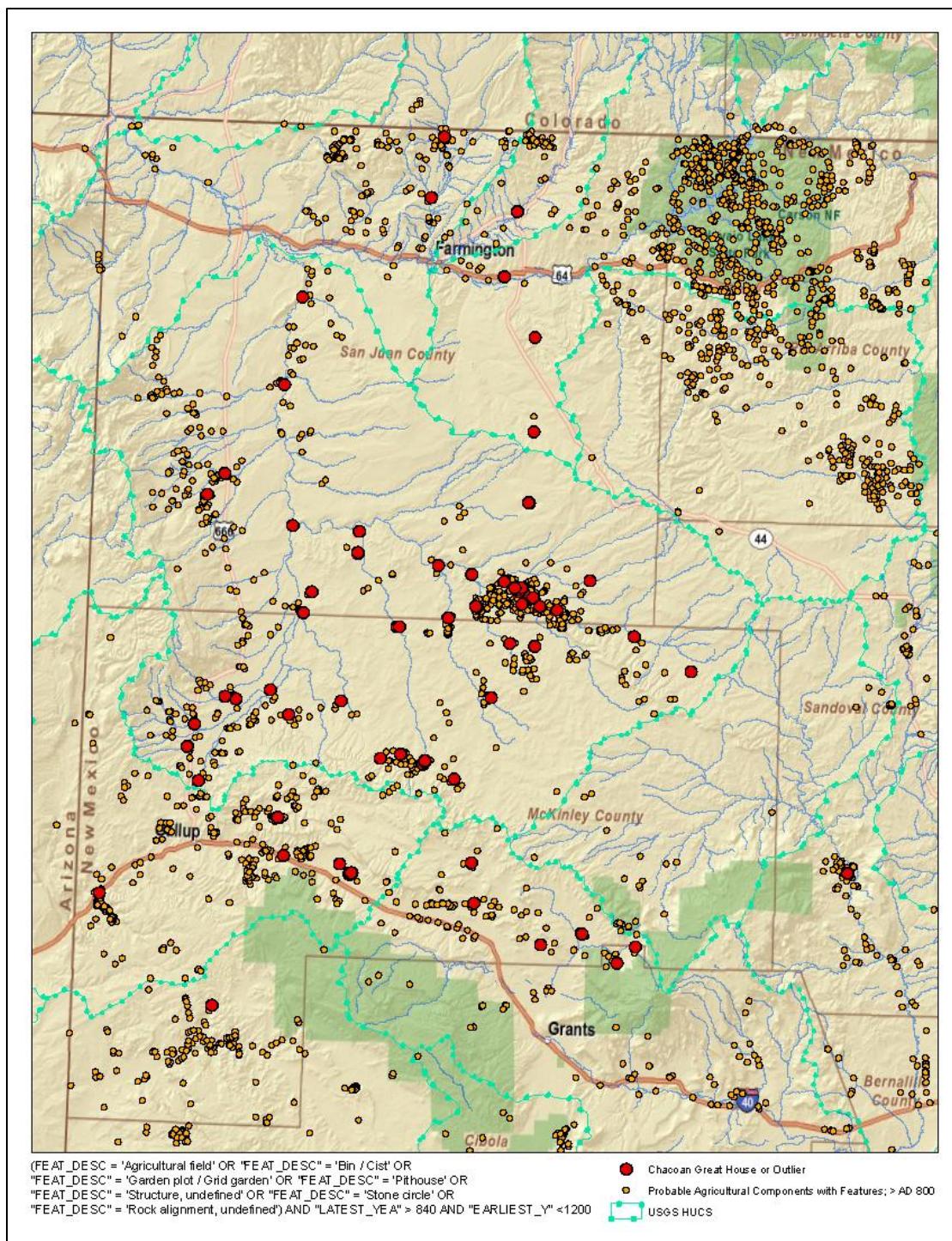

Figure 5-4: Sites with Probable Agricultural Components (ca. AD 840 – 1200)

As noted previously, the study utilizes a high resolution LiDAR elevation dataset, obtained through an NSF NCALM grant awarded to the author (Dorshow 2009). The LiDAR dataset covers more than 67 square kilometers in area in a swath that parallels the central axis of the canyon, which constitutes a value of more than \$50,000 (

Figure 5-5). In addition to supporting high resolution modeling of surficial hydrology, this dataset provides a wealth of untapped potential as a tool for archaeological and geological researchers and park management. In terms of park management, the dataset provides the opportunity to model change over time in in channel incision, trail erosion, and archaeological site integrity. The dataset provides a high-resolution basal DEM for integration with decimeter- to centimeter-resolution terrestrial LiDAR of specific outcrops, channel profiles, and site architecture.

The predictive geospatial model presented in the Chaco study provides a starting point for future collaborative research. As noted in the conclusions of the JAS article, my ongoing research is focused on creating a more refined water-loss raster analysis through the geospatial modeling of, pixel-specific measures of evapotranspiration and runoff, hydrologic regime and channel base level change, vegetation density and type, and other factors. These refinements will undoubtedly lead to a more realistic simulation of the Bonito Phase, which in turn will allow me to further refine agricultural yield estimates.

In addition to refining the current criteria employed in the model, my ongoing research considers the potential impacts of paleoclimatic risk factors on Bonito Phase agricultural productivity. Figure 5-6 shows a preliminary analysis of temperature regime risk within the study area, based solely on aspect. This simple example might be refined through the

additional consideration of cold-air drainage effects, prevailing wind patterns, and other factors. Figure 5-7 and Figure 5-8 show the results of another risk-related analysis that considers the impacts of catastrophic flooding. The first of these analyses used the heavily incised hydrologic scenario characteristic of the modern environment. The second simulates relative risk of catastrophic flooding given an aggraded scenario, which was achieved by arbitrarily infilling the modern channels. Ongoing UNM research associated with the Chaco Stratigraphy Project (Wirt Wills, personal communication February 2012) suggests the Bonito Phase may have been characterized by brief periods of channel incision followed by aggradation. This observation heightens the importance of modeling the relative potential for catastrophic flooding under varying hydrologic scenarios (base-level changes), particularly on canyon floors. Clearly, Bonito farmers would have hedged their risks, particularly during periods of channel aggradation, by distributing fields in areas away from major flood plains. This observation points to the implications of the model presented in Chapter 4, which suggests that upland contexts provided abundant zones of potentially arable land.

Another example of the integration of the Chaco agricultural potential study with ongoing archaeological research is manifested in several articles I coauthored with University of New Mexico collaborators. The first of these (Wills et al. 2012), entitled *Shabik'eschee Village in Chaco Canyon: Time to Move beyond the Archetype*, offers a reassessment of Shabik'eschee Village, a large Basketmaker II period (ca. AD 400 to 750) site in Chaco Canyon. My role in this study included the use of a terrestrial laser scanner (Optech Ilris) and Polyworks (v10) software to generate a decimeter resolution DEM along the newly expanded site boundary eroding into Chaco Wash.





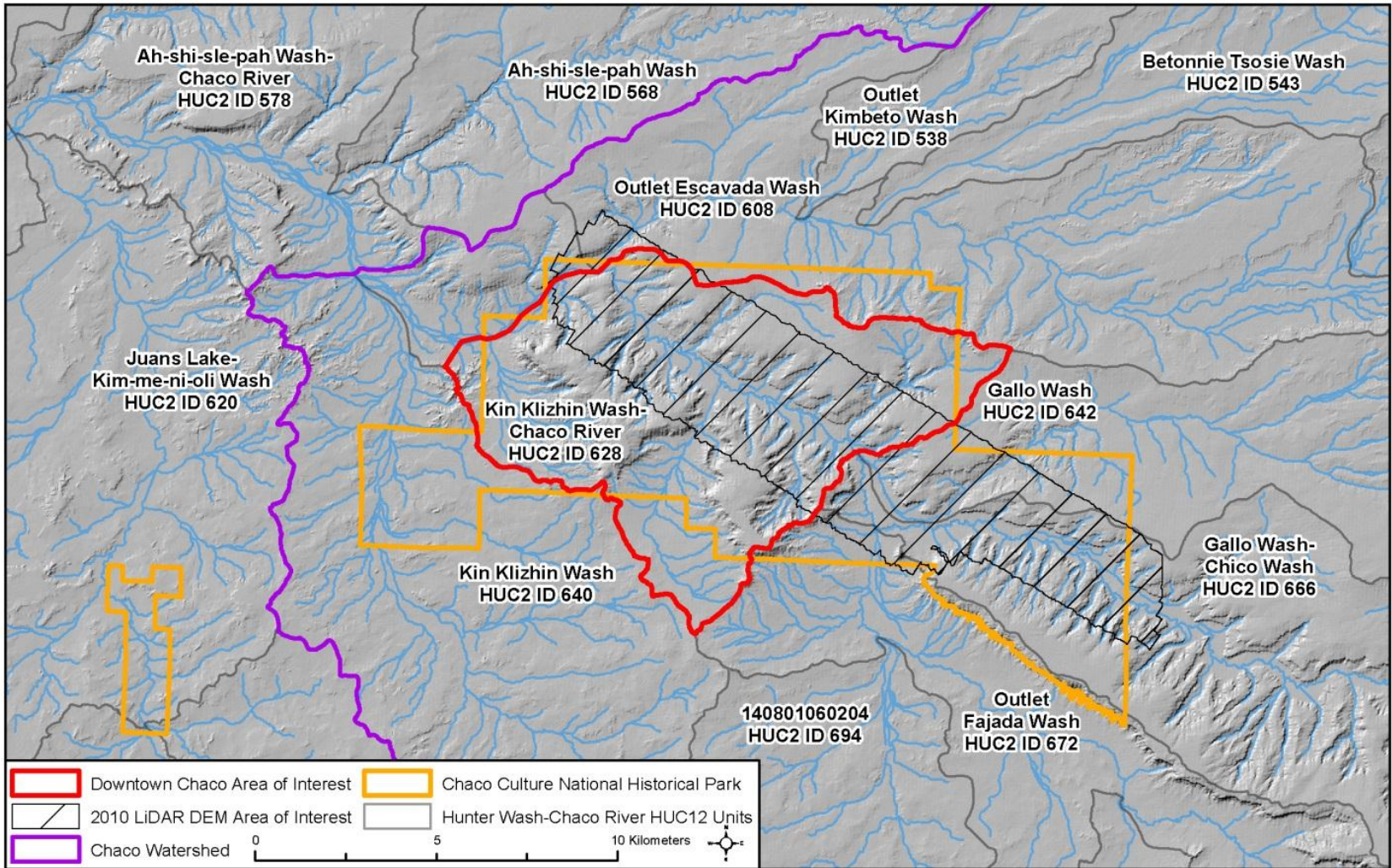

Figure 5-5: Extent of LiDAR Dataset Obtained through NCALM Grant (Dorshow 2009)

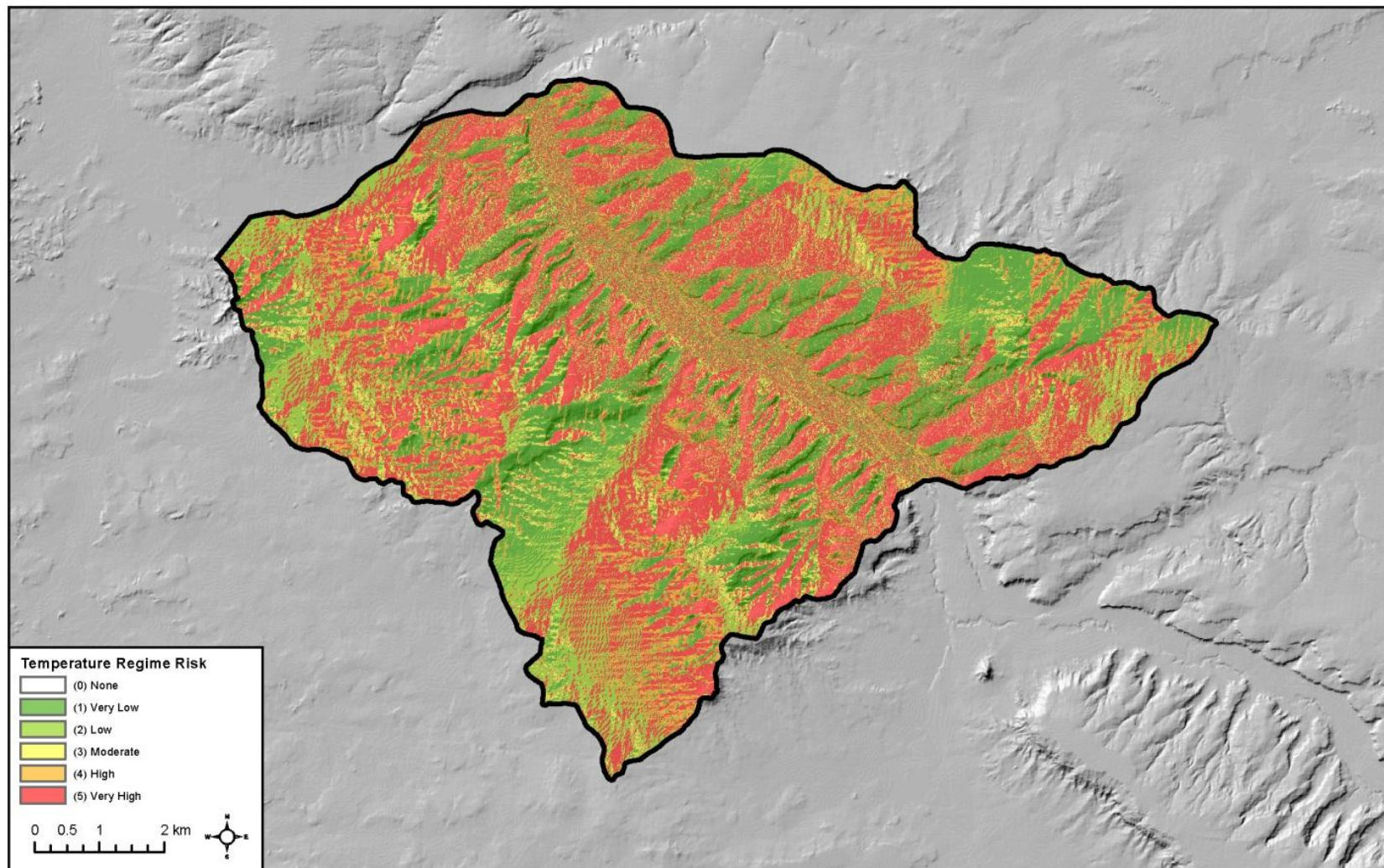

Figure 5-6: Temperature Regime Risk Analysis Results

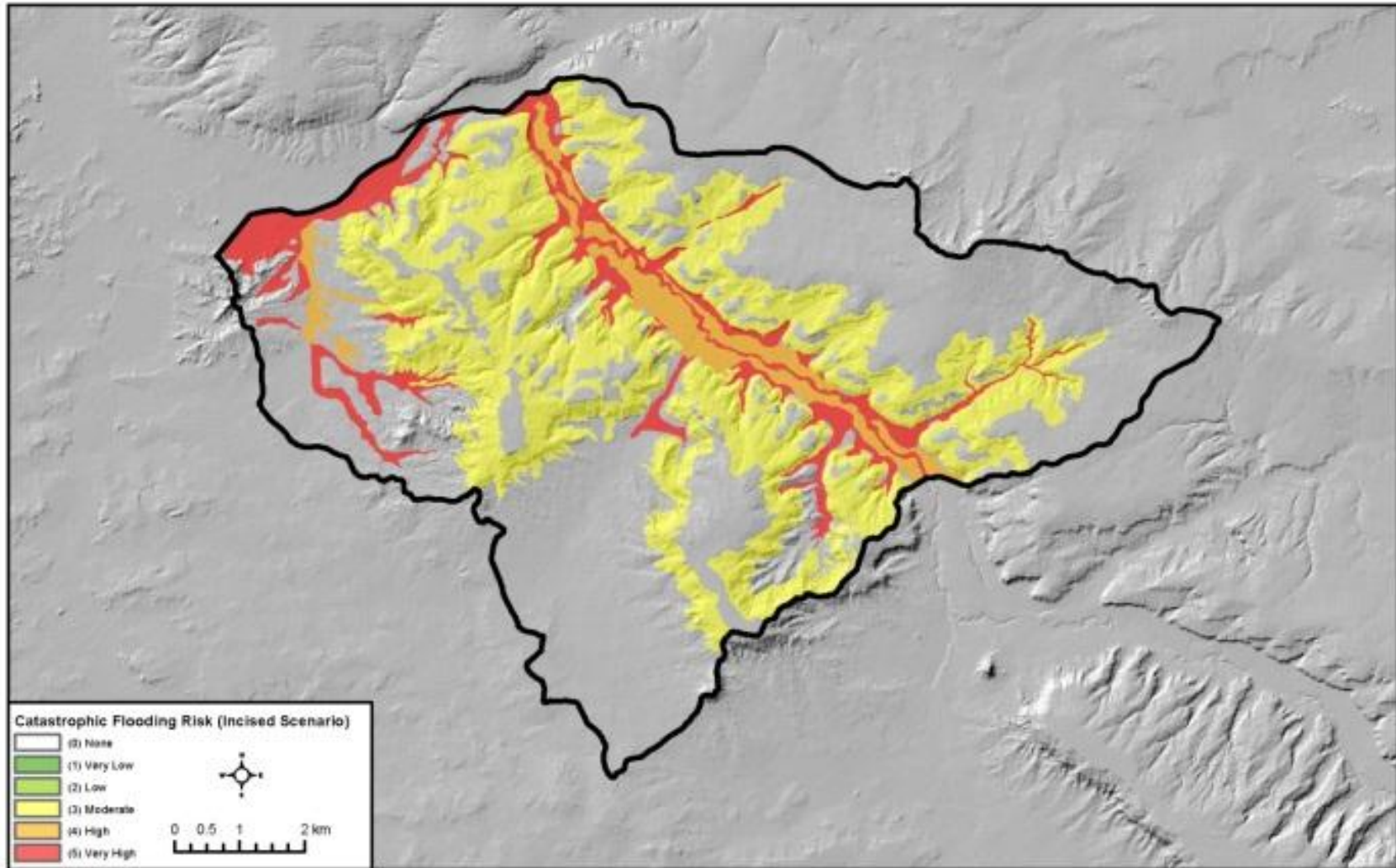

Figure 5-7: Catastrophic Flooding Risk, Incised Scenario

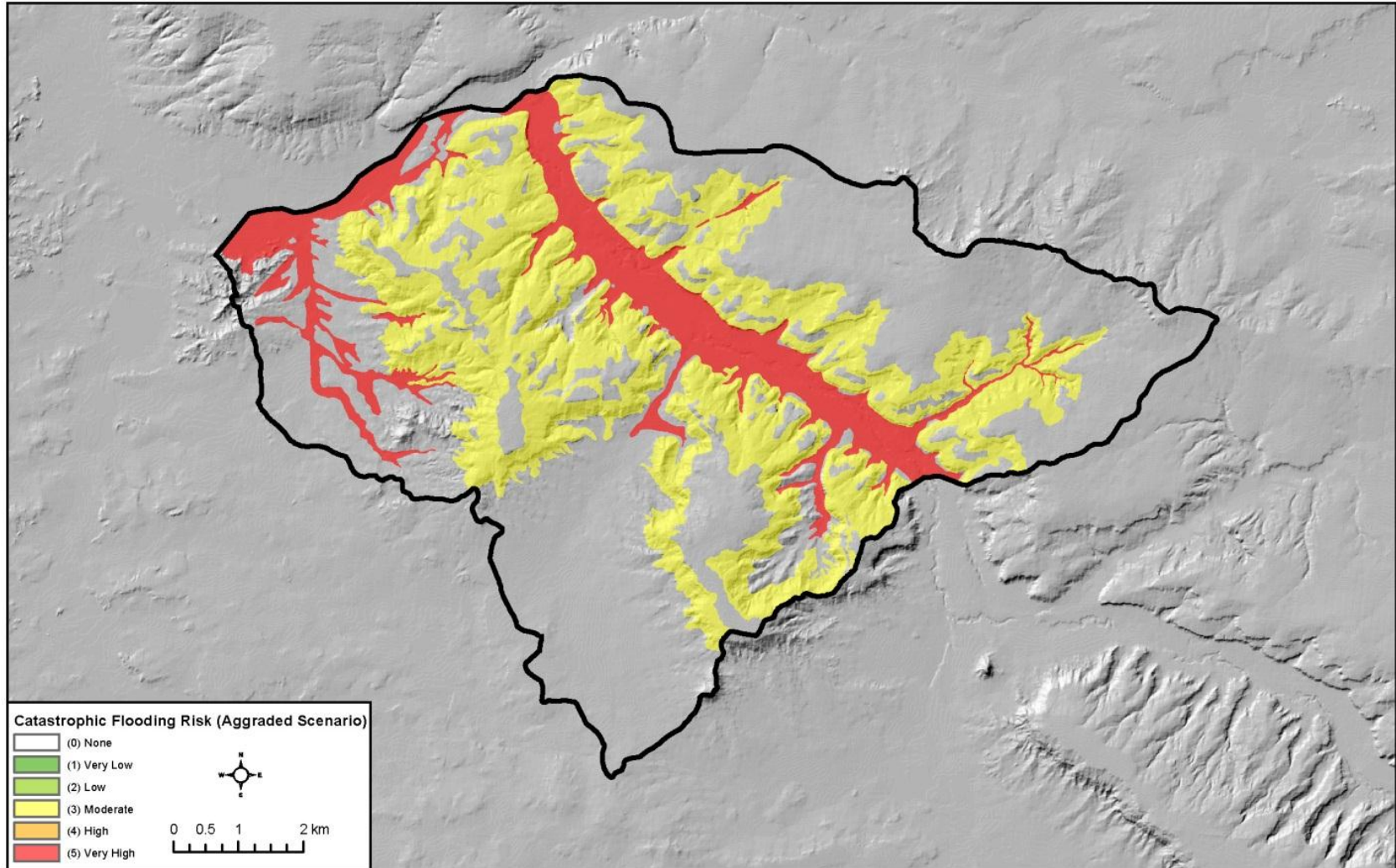

Figure 5-8: Catastrophic Flooding Risk, Aggraded Scenario

I also conducted a large scale regional GIS analysis of Basketmaker site distributions using a custom query of the New Mexico Archaeological Records Management System (ARMS) database. Data and results derived from these analyses were integrated into the larger, integrated GIS database I developed for Chaco Canyon as part of the agricultural potential analysis effort.

In another article I coauthored with Wirt Wills (Wills and Dorshow, 2012), we use my agricultural model to zoom in on the catchment that encompasses most of Alto mesa and argue for the probability that areas on the benches and mesas above the Chaco Canyon floor supported substantial agricultural productivity. This, in turn, is used to support the arguments that (1) Chaco was not marginal for farming during the Bonito Phase and (2) the positioning of Great House communities might correlate with deliberate efforts to manage and control one or more important control agricultural production zones within the region.

#### **5.4: Discussion**

The three case studies presented in this dissertation share some notable themes and offer some important contributions (Table 5-1). To begin, the studies are characterized by a standardized methodological approach involving collaborative criteria definition and weighted overlay analysis to evaluate the intersection of many natural and cultural variables over both modern and past environmental landscapes. These tools can be refreshed with new data and run under the same or differing criteria weighting strategies to evaluate various research or conservation scenarios.

Table 5-1: Case Study Themes

	<b>Predictive Geospatial Modeling</b>	<b>Land-use Planning, Public Policy and Conservation</b>	<b>NGO Conservation Initiatives</b>	<b>Archaeology and Cultural Resource Management</b>
<b>Galisteo Basin, NM</b>	Integrated 10M resolution DEM data with a custom extract of Archaeological site location and survey data from the NM ARMS system; predicts the relative potential for success in protecting specific lands in the face of real-world development pressures	Conservation prioritization model results used by County and State governments for Land-Use planning initiatives and addressing oil and gas development threats	Archaeological Easements, Special protection for major Classic Period Galisteo pueblos	Archaeological and Historic sites contribute 25% of the Conservation priorities analysis weighted overlay.
<b>State of Vermont</b>	Built a statewide model of 11 environmental criteria at 7.5m resolution; Predicts relative potential for encountering archaeological sites throughout the state	Statewide archaeological sensitivity analysis is used as a tool for land use and conservation policy at all levels of government (USFS, DHP)	The VTASM results are accessible to NGOs and academic researchers for use in conservation planning efforts;	VTASM results are established reference material for all Archaeological Resource Assessments submitted by consulting archaeologists since 2007; also used in Section 106 reviews by the Vermont Division for Historic Preservation and the Vermont Agency of Transportation
<b>Chaco Canyon</b>	Predictive geospatial model of agricultural potential during the 10 <sup>th</sup> and 11 <sup>th</sup> centuries based on a suite of six natural environmental factors	In the CCNHP, potential field areas might be considered in trail and road maintenance plans; the tools could be applied to other areas to minimize impacts on potential field areas in the face of development pressures	Maps of prehistoric (or historic) agricultural potential can support conservation efforts of NGOs	LiDAR data acquired through NCALM grant (Dorshow 2009) will facilitate site preservation, change monitoring, and maintenance by CCNHP staff into the future

Another common theme manifested in each case study is that the substantive, practical contributions of each of these studies have been recognized publicly and or endorsed by state and local government. The following paragraphs elaborate on this assertion for each case study.

The VTASM team was given a “Special Achievement in GIS Award” by Environmental Systems Research Institute in the summer of 2006. This award typically is granted to organizations that use “GIS to improve our world- and set new precedents throughout the GIS community” (ESRI.com/SAG).

The GWCI analysis results have been used by the Santa Fe County Planning Department in developing a Sustainable Land Management Plan and making open space acquisition decisions (EarthLines, Winter 2011). Additionally, the study was cited in a 2008 moratorium on oil and gas development in the Galisteo Basin by the New Mexico state government (EarthLines, Winter 2011).

The Chaco analysis was enhanced greatly by high resolution LiDAR dataset covering a 40 hectare swath of Chaco Canyon that I obtained through a Dissertation Seed Grant from the National Center for Airborne Laser Scanning, a National Science Foundation program (Dorshow 2010). This important new dataset offers multiple overlapping advantages that extend beyond the immediate goals of the agricultural potential analysis, contributing to ongoing archaeological investigations in Chaco Canyon by the University of New Mexico (See <http://www.unm.edu/~Chaco>) and facilitating efforts by the National Park Service to monitor erosion and support historic preservation efforts within the CCNHP.

The Galisteo and Vermont projects are real-world examples of the use of GIS to balance competing goals of conservation and development. Although the central objective of the Chaco study is more academic in focus than the Vermont and Galisteo conservation prioritization projects, the delineation of high-probability field areas provides relevant information for consideration by cultural resources management staff at the Chaco Culture National Historic Park (CCNHP). Many of these potential field areas occur outside the boundaries of documented archaeological sites within the park. With further documentation, these potential field areas might warrant protection from development and maintenance activities within the park.

These three studies clearly demonstrate that collaborative multi-criteria geospatial analysis provides an invaluable foundation for empirically sound, non-destructive, and economically feasible archaeological research, cultural resources management, and land-use planning strategy. This type of analysis is now commonplace in private, commercial and governmental efforts to mitigate the environmental and social impacts of energy, infrastructure, and real estate development through smart planning and economically sustainable policy initiatives. Not surprisingly, geospatial analysis constitutes an increasingly common theme in archaeological research (Kvamme 1995, 2006; McCoy and Ladefoged 2009; Burke et al. 2008; Howey 2011). As the discipline of archaeology becomes increasingly intertwined with issues of conservation, public policy and environmental management, I suggest that detailed, high-resolution, landscape-scale, multi-criteria geospatial analysis will become an ever more important and prevalent component of practical and effective problem-oriented archaeological research.



## References Cited

- Banks, W.E., F. d'Errico, H. Dibble, L. Krishtalka, D. West, D.I. Olszewski, A. Townsend Peterson, D.G. Anderson, J.C. Gillam, A. Montet-White, M. Crucifix, C.W. Marean, M.F. Sánchez-Goñi, B. Wohlfarth, M. Vanhaeran, 2006. Eco-cultural niche modeling: new tools for reconstructing the geography and ecology of past human populations. *Paleoanthropology*, 2006 (2006), pp. 68–83.
- Barton, C.M. , Ullah, I. , Mitasova, H., 2010  
Computational modeling and neolithic socioecological dynamics: A case study from Southwest Asia. *American Antiquity*, 75 (2), pp. 364-386.
- Benson, L.V., 2011a. Factors Controlling PreColumbian and Early Historic Maize Productivity in the American Southwest, Part 1: The Southern Colorado Plateau and Rio Grande Regions. *J Archaeological Method Theory*, v. 18, no. 1, p. 1-60.
- Benson, L.V., 2011b. Factors Controlling Pre-Columbian and Early Historic Maize Productivity in the American Southwest, Part 2: The Chaco Halo, Mesa Verde, Pajarito Plateau/Bandelier, and Zuni Archaeological Regions. *J. Archaeological Method Theory*, v. 18, no. 1, p. 61-109.
- Benson, L., Stein, J., Taylor, H., Friedman, R., and Windes, T.C., 2006. The agricultural productivity of Chaco Canyon and the Source(s) of Pre-Hispanic Maize Found in the Pueblo Bonito Great House, in Staller, J.E., and others (Eds.), *Histories of Maize - Multidisciplinary Approaches to the Prehistory, Linguistics, Biogeography, Domestication, and Evolution of Maize*. Elsevier/Academic Press, San Diego, pp. 289-314.
- Benson, L., Cordell, L., Vincent, K., Taylor, H., Stein, J., Farmer, G., and Kiyoto, F., 2003. Ancient Maize from Chacoan Great Houses: Where was it Grown? *Proceedings of the National Academy of Sciences*, v. 22, p. 13111-13115.
- Binford, L., 1962. *Archaeology as Anthropology*. In *Contemporary Archaeology*, ed. by M. Leone, pp. 93–101. Southern Illinois University, Carbondale.
- Bradfield, M., 1971. *The Changing Pattern of Hopi Agriculture*. Royal Anthropological Institute, London.
- Bryan, K., 1954. *The Geology of Chaco Canyon, New Mexico*. Smithsonian Miscellaneous Collection, v. 122, no. 7, p. 1-65.

Burke, A., D. Ebert, J. Cardille, and D. Dauth, 2008. Paleoethology as a Tool for the Development of Archaeological Models of Land-Use: The Crimean Middle Palaeolithic. *Journal of Archaeological Science* V. 35, Issue 4, pp. 894-904.

Clark, S. P. 1928. Lessons from southwestern Indian agriculture. *Agricultural Experiment Bulletin* 125. University of Arizona, Tucson.

Crown, P.L. and Judge, J., 1991. Synthesis and Conclusions, in P.L. Crown and W. J. Judge, Jr. (Eds.), *Chaco and Hohokam: Prehistoric Regional Systems in the American Southwest*, School of American Research Press, Santa Fe, pp. 293-308.

Dominguez, S., & Kolm, K.E., 2005. Beyond Water Harvesting: A Soil Hydrology Perspective on Traditional Southwestern Agricultural Technology. *Am. Antiq.*, V. 70, pp. 732-765.

Dorshow, W.B., 2006. Modeling Archaeological Sensitivity in Vermont with GIS. *ArcNews*, Spring 2006. ESRI Press, Redlands, CA.

Dorshow, W.B, 2008. Modeling Paleohydrology in Archaeological Contexts with Terrestrial LIDAR and GIS: A Chaco Canyon Case Study. Paper presented in a symposium entitled *The Chaco Stratigraphy Project: Ongoing Research and Preliminary Results*, Chaired by W. Wills and P.V. Crown, Society for American Archaeology Annual Meeting, March 26-30, 2008, Vancouver.

Dorshow, W.B., 2009. Simulating Dynamic Hydrological Processes in Archaeological Contexts: A Proposal for Airborne Laser Swath Mapping (ALSM) at Chaco Canyon. Grant Proposal Submitted to the National Center for Airborne Laser Mapping.

Dorshow, W.B, 2010a. GIS-based Landscape Reconstruction of the Chaco Core during the Bonito Phase. Paper presented in a symposium entitled *Pueblo Bonito Mounds Research: Formation Processes and Artifact*, chaired by W. Wills and P.L. Crown. Society for American Archaeology Annual Meeting, St. Louis.

Dorshow, W.B., 2010b. Quantifying Potential Agricultural Productivity during the Bonito Phase at Chaco Canyon with ArchaeoFlow, a GIS-based Paleohydrologic Simulation Framework. Doctoral Dissertation Proposal, Manuscript on File, University of New Mexico, Department of Anthropology, Albuquerque, NM.

Dorshow, W.B., In Press. Modeling Agricultural Potential in the Chaco Canyon during the Bonito Phase: A Predictive Geospatial Approach. *Journal of Archaeological Science*. Accepted 3 February 2012. Available online 24 March 2012.

Dorshow, W.B., 2007. Vermont Archaeological Sensitivity GIS Model Description and User's Guide. Vermont Division for Historic Preservation, Montpelier, VT.

Earth Lines, 2011. Santa Fe Conservation Trust Newsletter. Santa Fe Conservation Trust, Santa Fe, NM.

ESRI, 2012. ArcGIS 10.0 Support Website. Environmental Systems Research Institute, [HTTP://www.ESRI.com/10.0/webhelp](http://www.ESRI.com/10.0/webhelp).

Fagan, B., 2005. Chaco Canyon. Oxford University Press, USA

Jansens, J.W., Peterson, R., and Dorshow, W.B., 2012. Galisteo Watershed Conservation Initiative: Quality of Life at a Crossroads. Santa Fe Conservation Trust, Santa Fe, NM. [http://www.earthanalytic.com/GWCI\\_FinalReport.pdf](http://www.earthanalytic.com/GWCI_FinalReport.pdf).

K.V. Flannery (1968). Archaeological Systems Theory and Early Mesoamerica". In *Anthropological Archaeology in the Americas*, ed. by B. J. Meggers, pp. 67-87. Washington, Anthropological Society of Washington.

Force, E.R., Vivian, R.G., Windes, T.C., and Dean, J.S., 2002. Relation of "Bonito" Paleo-channels and Base Level Variations to Anasazi Occupation, Chaco Canyon, New Mexico. *Archaeological Series 194*. Arizona State Museum, University of Arizona, Tucson.

Forde, C. D., 1931. Hopi Agriculture and Land Ownership. *Journal of the Royal Anthropological Institute*, Vol. 61, July-December 1931, pp. 357-405.

Hack, J., 1942. The Changing Physical Environment of the Hopi Indians of Arizona. *Reports on the Awatovi Expedition*, no. 1, *Papers of the Peabody Museum of American Archaeology*, vol. 35, no. 1 Cambridge: Harvard University.

Hall, S., 1977. Late Quaternary Sedimentation and Paleoecologic History of Chaco Canyon, New Mexico. *Geological Society of America, Bulletin*, v. 88, pp. 1593-1618.

Hall, S., 1988. Prehistoric Vegetation and Environment at Chaco Canyon. *American Antiquity*, v. 53, p. 582-592.

- Hall, S., 2010. Early Maize Pollen from Chaco Canyon, New Mexico, USA. *Palynology*; 2010; v. 34;1, pp. 125-137.
- Homburg, J.A., J.A. *Sandor*, and J.B. Norton, 2005. Anthropogenic Influences on Zuni Agricultural Soils. *Geoarchaeology*, V.20, pp. 661-693.
- Howey, Meghan C. L, 2007. Using Multi-criteria Cost Surface Analysis to Explore Past Regional Landscapes: A Case Study of Ritual Activity and Social Interaction in Michigan, AD 1200–1600. *Journal of Archaeological Science*, Volume 34, Issue 11, pp. 1830-1846.
- Howey, Meghan C. L., 2011. Multiple Pathways across Past Landscapes: Circuit Theory as a Complementary Geospatial Method to Least Cost Path for Modeling Past Movement. *Journal of Archaeological Science*, v38, pp. 2523-2535.
- Jankowski P, Richard L, 1994. Integration of GIS-based Suitability Analysis and Multicriteria Evaluation in a Spatial Decision Support System for Route Selection. *Environment and Planning B: Planning and Design*, 21(3), pp. 323 – 340.
- Kvamme, K., 1995. A View from across the Water: The North American experience in Archaeological GIS. G. Lock, Z. Stancic (Eds.), *Archaeology and Geographical Information Systems*, Taylor and Francis, London (1995), pp. 1–14.
- Kvamme, K., 1999. Recent Directions and Developments in Geographical Information systems. *Journal of Archaeological Research*, 7(2), pp. 153-201.
- Kvamme, K., 2006. There and Back Again: Revisiting Archaeological Locational Modeling. In: Mehrer, M.W., Wescott, K.L. (Eds.), *GIS and Archaeological Site Location Modeling*. Taylor & Francis, Boca Raton, London, New York, pp. 3-40.
- Kirkby, A.V.T., 1973. The Use of Land and Water Resources in the Past and Present Valley of Oaxaca, Mexico. In K.V. Flannery (Ed.), *Prehistory and Human Ecology of the Valley of Oaxaca*, *Memoirs of the Museum of Anthropology*, University of Michigan, Number 5, Ann Arbor.
- Lekson, S.L., 1984. Great Pueblo Architecture of Chaco Canyon, New Mexico. *Publications in Archeology 18B*, Chaco Canyon Studies. National Park Service, Albuquerque.

Lekson, S.L., 2007. *The Architecture of Chaco Canyon, New Mexico*. University of Utah Press, Salt Lake City, Utah.

Love, D., 1980. *Quaternary Geology of Chaco Canyon, Northwestern New Mexico*. Ph.D dissertation, University of New Mexico, Albuquerque. University Microfilms International, Ann Arbor.

Love, D., 1983. *Quaternary Facies in Chaco Canyon and Their Implications for Geomorphic Sedimentological Models*, in: Wells, S., Love, D., Love, T. Gardner, D. (Ed.), *Chaco Canyon 39 Country*, Gardner American Geomorphical Field Group, Adobe Press, Albuquerque, pp. 195-206.

Maidment, D., 2002. *ArcHydro GIS for Water Resources*. ESRI Press, Redlands, CA.

Manolescu, K., 1995. *Hopi Corn Production. A Report on Research Conducted for the Bureau of Indian Affairs, Phoenix Area Office*. MS on file at Hopi Cultural Preservation Office, Kykotsmovi, Arizona.

Maxwell, T.D., Anschultz, K.F., 1992. *The Southwestern Ethnographic Record and Prehistoric Agricultural Diversity*. In *Gardens of Prehistory: The Archaeology of Settlement Agriculture in Greater Mesoamerica*. Thomas W. Killion, ed. pp. 35-68. Univ. of Alabama Press: Tuscaloosa.

McDonald, L., Allen, W., Benedict, M., & O'Connor, K., 2005. *Green Infrastructure Plan Evaluation Frameworks*. *Journal of Conservation Planning*, Vol. 1, Issue 1.

Ritchie, S.W., J.J. Hanaway and G.O. Benson, 1992. *How a Corn Plant Develops*. Cooperative Extension Service Special Report, No. 48. Iowa State University, Ames, Iowa.

Sandor, J.A., Norton, J.B., Homburg, J.A., Muenchrath, D.A., White, C.S., Williams, S.E., Havener, C.I., & Stahl, P.D., 2007. *Biogeochemical Studies of a Native American Runoff Agroecosystem*. *Geoarchaeology* v. 22, pp. 359-386.

Seaber, P.R., Kapinos, F.P., and Knapp, G.L., 1987. *Hydrologic Unit Maps: U.S.* Geological Survey Water-Supply Paper 2294, 63 p, Washington D.C..

Sebastian, Lynne, 1992. *The Chaco Anasazi: Sociopolitical Evolution and the Prehistoric Southwest*, Cambridge University Press, Cambridge.

Simmons, A.H., 1986. New Evidence for the Early Use of Cultigens in the American Southwest. *American Antiquity*, v. 51, No. 1, pp. 73-89.

Simley, J.D., Carswell Jr., W.J., 2009, The National Map - Hydrography: U.S. Geological Survey Fact Sheet, pp. 2009-3054. <http://pubs.usgs.gov/fs/2009/3054/pdf/FS2009-3054.pdf>.

USGS National Elevation Dataset Website, 2011  
<http://ned.usgs.gov/>.

USGS National Hydrographic Dataset Website, 2011  
<ftp://nhdftp.usgs.gov/DataSets/Staged/SubRegions/FileGDB/HighResolution/>

Vivian, R. G., 1972. Prehistoric Water Conservation in Chaco Canyon, NSF Grant No. GS-3100, July 1, 1970 to June 31, 1971. Arizona State Museum, University of Arizona, Tucson.

Vivian, R. G., 1974. Conservation and Diversion: Water-control Systems in the Anasazi Southwest. In T.E. Downing and M. Gibson (Eds.), *Irrigation's Impact on Society*, Anthropological Papers of the University of Arizona, No.25., University of Arizona, Tucson, pp. 95-112.

Vivian, R. G., 1990. *The Chacoan Prehistory of the San Juan Basin*. Academic Press, New York.

Weide, D.L., Schneider, G.B., Mytton, J.W., and Scott, G.R., 1979. Geologic Map of the Pueblo Bonito Quadrangle, San Juan County, New Mexico. U.S. Geological Survey, Miscellaneous Field Studies Map MF-1119, 1:24000 Scale.

Wills, W. Reconsidering the Pueblo Alto Community: A Geospatial Perspective. Paper presented at the 2011 Annual Meeting of the Society for American Archaeology. University of New Mexico, Department of Anthropology. Albuquerque.

Wills, W. and W.B. Dorshow, 2012. Chaco Great House Communities and Agricultural Productivity: Revisiting Pueblo Alto. *Journal of Anthropological Archaeology*. v.31, Issue 2, pp. 138-155.

Wills, W., F.S. Worman, W. B. Dorshow, and H. Richards, In Press. Shabik'eschee Village in Chaco Canyon: Time to Move Beyond the Archetype. *American Antiquity* (April 2012).