

Université de Montréal

Globin Gene Expression: Role of Transcription Factors

par

Alireza Fotouhi Ghiam

Programmes de biologie moléculaire

Faculté de médecine

Mémoire présenté à la Faculté de médecine

en vue de l'obtention du grade de Maîtrise ès Sciences (M.Sc.)

en biologie moléculaire

Août, 2009

© Alireza Fotouhi Ghiam, 2009

Université de Montréal
Faculté des études supérieures

Ce mémoire intitulée :

Globin Gene Expression: Role of Transcription Factors

présentée par :
Alireza Fotouhi Ghiam

a été évaluée par un jury composé des personnes suivantes :

Dr. Dindial Ramotar
Président-rapporteur
Dr. Eric Milot
Directeur de recherche
Dr. Chaim Shustik
Membre du jury

Résumé

La dérégulation de l'expression génétique est une base pathophysiologique de plusieurs maladies. On a utilisé le locus du gène β -globine humaine comme modèle pour élucider le mécanisme de régulation de la transcription génétique et évaluer son expression génétique durant l'érythropoïèse. La famille des protéines 'E' est composée de facteurs de transcription qui possèdent plusieurs sites de liaison au sein de locus du gène β -globine, suggérant leur rôle potentiel dans la régulation de l'expression de ces gènes. Nous avons montré que les facteurs HEB, E2A et ETO2 interagissent d'une manière significative avec la région contrôle du Locus (LCR) et avec les promoteurs des gènes de la famille β -globine. Le recrutement de ces facteurs au locus est modifié lors de l'érythropoïèse dans les cellules souches hématopoïétiques et les cellules érythroïdes de souris transgéniques pour le locus de la β -globine humaine, ainsi que dans les cellules progénitrices hématopoïétiques humaines. De plus par cette étude, nous démontrons pour la première fois que le gène β -globine humaine est dans une chromatine active et qu'il interagit avec des facteurs de transcriptions de type suppresseurs dans les cellules progénitrices lymphoïdes (voie de différenciation alternative). Cette étude a aussi été faite dans des souris ayant une génétique mutante caractérisée par l'absence des facteurs de transcription E2A ou HEB.

Mots-clés: Expression, Facteur de Transcription, Génétique, Gène, Hématopoïèse, Lignée Spécification

Abstract

Aberrant gene expression is an underlying pathophysiology in many disease conditions. Lineage-specification and -commitment is tightly dependent on lineage-specific transcription factors to regulate the expression of target genes. Using human β -globin locus as a model, we investigated how the transcriptional machinery is set and regulated during erythropoiesis and how it impacts globally on gene expression. Class I bHLH proteins are important transcription factors whose binding sites are frequently clustered throughout the β -globin gene locus, suggesting their role in globin gene regulation. We showed that, in hematopoietic progenitor (HPC) and erythroid cells (EryC) of the transgenic mouse for human β -globin locus and human HPC cells (CD34⁺); HEB, E2A and ETO-2 significantly interact with locus control region (LCR) and promoters of globin genes, and their relative ratio is altered during erythropoiesis. For the first time, we found that in other hematopoietic lineages, human β -globin locus is in active chromatin and interacts with transcription factors involved in repression. Strikingly and consistent with the expression of globin genes, we characterized transcription factors involved in open chromatin configuration and basal level of globin gene expression in lymphoid progenitor cells. Further, with the genetic power of E2A and HEB knockout mice, our findings were clarified in mutant backgrounds.

Keywords: Globin, Gene Expression, Hematopoiesis, Lineage Specification, Transcription Factor

Table des matières

Résumé.....	iii
Abstract.....	iv
Table des matières.....	v
Liste des tableaux.....	viii
Liste des figures.....	ix
Liste des sigles et des abréviations.....	xi
Remerciements.....	xv
Introduction.....	16
Hematopoiesis.....	17
Hematopoietic Stem Cell (HSC)	18
Lineage specification of HSCs.....	19
Erythropoiesis.....	20
Hemoglobin Synthesis.....	21
Hemoglobinopathies.....	22
Thalassemia.	22
Sickle Cell Disease.	23
Human β -globin locus.....	24
Globin gene expression.....	25
Globin gene expression and LCR.....	26
Globin gene expression and transcription factors.....	29
Transcription factors and Erythropoiesis.....	30
Helix-Loop-Helix (HLH) proteins.....	33
Helix-Loop-Helix (HLH) proteins: Regulators of transcription in eukaryotic organisms...	33
Classification and structure.....	33
E proteins and hematopoesis.....	36
E proteins in lymphoid-lineage.....	37
E proteins and ETO family.	38

Applications of study.....	42
Molecular application.....	42
Clinical application.....	42
Research Proposal.....	42
Rational.....	42
Hypothesis.....	45
Objectives.....	45
Materials and Methods.....	47
Mouse models.....	48
Line 2 mouse.....	48
(E2A +/- In2 +/-) and (HEB +/- In2 +/-) mice.....	48
Cell Sorting.....	49
Murine erythroid cells (Ter-119+) and Murine HPCs (Ly-6C-CD31 ^{high} -Kit+)......	49
Murine Lymphoid Progenitors (LPs) (Lin-c-Kit+Sca1+IL-7R α +)......	50
Human primitive progenitor cells (CD34+)......	50
Genotyping.....	51
Chromatin Immunoprecipitation (ChIP) assay.....	52
Real-time Polymerase Chain Reaction (Q-PCR/qPCR)......	53
Real-time Reverse Transcriptase Polymerase Chain Reaction (RT-PCR)......	54
Western blot.....	54
in vitro clonogenic assays.....	55
Results.....	56
Chapter One: Lineage-Specific Transcription Factors in Multipotent Hematopoietic Progenitors: A Little Bit Goes a Long Way.....	57
HEMATOPOIESIS AND LINEAGE SPECIFICATION.....	59
POTENTIATION AND GENE PRIMING IN HPCs.....	61
β -GLOBIN GENE POTENTIATION: THE ROLE OF LINEAGE-SPECIFIC TFs.....	63
β -GLOBIN GENE POTENTIATION: THE ROLE OF LCR-LIKE STRUCTURES.....	67

CONCLUDING REMARKS	68
Chapter One Supplementary section.....	69
Chapter two: The basic helix-loop-helix transcription factors E2A and HEB are involved in globin gene expression.....	71
Identification of factors bound to the human β -globin locus in erythroid cells and murine HPCs.....	72
Identification of factors bound to the human β -globin locus in human primitive progenitor cells.....	76
Identification of factors bound to the human β -globin locus in murine lymphoid progenitor (LP: Lin-c-KitlowSca1lowIL-7R α +) cells.....	80
Identification of factors bound to the human β -globin locus in fetal erythroid cells with E2A and HEB knock-out background.....	85
Discussion.....	88
Human β -globin locus in erythroid cells and murine HPCs.....	90
Human β -globin locus in human primitive progenitor cells.....	91
Human β -globin locus in murine lymphoid progenitor cells (LPs).....	92
E2A and HEB are associated with lineage- differentiation and commitment.....	94
Human β -globin locus in E2A and HEB knock-out fetal erythroid cells.....	95
Conclusion.....	97

Liste des tableaux

Table 1- Role of Transcription factors in Erythropoiesis

Table 2- Classification of bHLH proteins

Table 3- The ratio of LP (lymphoid progenitor) cells/Total Bone Marrow was calculated by limiting dilutions using the LDA program

Liste des figures

Figure 1- Hematopoiesis in humans

Figure 2- Hematopoiesis and stromal cell differentiation

Figure 3- Hemoglobin structure

Figure 4- Types of normal hemoglobin

Figure 5- Structure of human β -globin locus

Figure 6- Structure of a MyoD basic-helix-loop-helix (bHLH) transcription factor

Figure 7- Model of Ldb1 complexes in uninduced MEL cells

Figure 8- Genetic regulatory networks (GRNs) programming hematopoietic stem cells and erythroid lineage specification

Figure 9- One representative experiment of genotyping

Figure 10- Chromatin immunoprecipitation (ChIP) assays on Mac-1+, B220+, and common lymphoid progenitor (CLP) cells

Figure 11- Chromatin immunoprecipitation (ChIP) assays on common myeloid progenitor (CMP), wild type erythroid (EryC), and EKLF knock-out erythroid (EKLF KO) cells

Figure 12- Model of TFs recruitment at the hu β -globin locus in HPCs and EryCs

Figure 13- Chromatin immunoprecipitation (ChIP) assays on human CD34+ multipotent HPCs cells

Figure 14- Analysis of hematopoietic cells from In2 bone marrow mice with Ter119 and Ly-6C/CD31/c-Kit expression

Figure 15- Chromatin immunoprecipitation (ChIP) assays on murine erythroid cells (EryC, Ter119+) and murine hematopoietic progenitor cells (HPC, Ly-6C-CD31^{high}-Kit+)

Figure 16- Purification of human hematopoietic progenitor cells (CD34+)

Figure 17- Chromatin immunoprecipitation (ChIP) assays on human CD34+ multipotent HPCs cells

Figure 18- Purification of murine lymphoid progenitor (LP: Lin-c-Kit^{low}Sca1^{low}IL-7R α +) cells

Figure 19- Whitlock-Witte long-term bone marrow culture

Figure 20- ChIP analysis of histone acetylation and interaction of E2A, HEB and ETO-2 proteins with the human β -globin locus in LP (Lin-c-KitlowSca1lowIL-7R α +) cells from adult In2 mice

Figure 21- ChIP assays on fetal liver erythroid cells (13.5 dpc) with wild-type and knock-out backgrounds

Liste des sigles et des abréviations

Ab: antibody

AGM: aorta-gonad-mesonephros region

AML: acute myeloid leukemia

APC: allophycocyanin

BFU-E: burst forming units-erythroid

bHLH: basic helix-loop-helix

CD: cluster of differentiation

CFC: colony-forming cell

CFU-E: colony-forming units-erythroid

CFU-G: colony-forming units-granulocyte

CFU-GEMM: colony forming units-granulocyte-erythroid-macrophage-megakaryocyte

CFU-GM: colony forming units-granulocyte-macrophage

ChIP: chromatin immunoprecipitation

CLP: common lymphoid progenitor

CMP: common myeloid progenitor

CO₂: carbon dioxide

CTD: C-terminal domain

Ct: threshold cycle

DIVA: DIgitalized VAntage

dpc: day post coitus

EDTA: ethylenediaminetetraacetic acid

EKLF: erythroid kruppel-like factor

EKLF KO: EKLF knock-out

EO: eight twenty-one

EPO: erythropoietin

EryC: erythroid cell

ES: embryonic stem

FAB: French-American-British
FACS: fluorescence-activated cell sorter
FBS: fetal bovine serum
FITC: fluorescein isothiocyanate
FL: fetal liver
FOG-1: friend of GATA-1
G-CSF: granulocyte colony-stimulating factor
GD: gestational day
GM-CSF: granulocyte monocyte-stimulating factors
GMP: granulocyte macrophage progenitor
GRN: genetic regulatory network
GTF: general transcription factor
H3Ac : histone H3 acetylation
Hb: hemoglobin
HDAC: histone deacetylase
HEB: Hela E-box binding protein
HLH: helix-loop-helix
HPC: hematopoietic progenitor cell
HS: hypersensitivity sites
HSC: hematopoietic stem cell
Hu β : human β
Id: inhibitor of differentiation
Igh: immunoglobulin heavy chain
IFN- α : interferon- α
K4: lysine 4
K9: lysine-9
Kb: kilobase
LCR: locus control region

Ln2: line 2
LP: lymphoid progenitor
LTBMC: long term bone marrow culture
mSin3: mammalian Sin3
MEL: murine erythroleukemic
MEP: megakaryocyte erythroid progenitor
MRF: muscle regulatory factor
MTG16: myeloid transforming gene chromosome 16
MTGR1: myeloid transforming gene related protein-1
MW: molecular weight
NaB: sodium butyrate
NO: nitric oxide
NuRD: nucleosome remodeling and deacetylation
O2: oxygen
p21: CDKN1A; cyclin-dependent kinase inhibitor 1A
Pax6: paired box protein 6
PBS: phosphate-buffered saline
PCR: polymerase chain reaction
PE: phycoerythrin
PEV: position effect variegation
PIC: preinitiation complex
QRT-PCR: quantitative real time polymerase chain reaction
RBC: red blood cell
RT-PCR: Reverse Transcriptase Polymerase Chain Reaction
SCF: stem cell factor
SCL: stem cell leukemia
SDS/PAGE: SDS-polyacrylamide gel
TAL-1: T-cell acute lymphocytic leukemia-1

TFN: transcription factor network

THP: kidney-specific Tamm-Horsfall

TSA: trichostatin A

W-W: whitlock-white

Remerciements

I would like to express a deep sense of gratitude to my supervisor, Dr. Eric Milot, for constant and generous support, encouragement, guidance and understanding. He is a professional in the field and may serve as the beautiful example to follow.

I would also like to thank Dr. Stefania Bottardi who helped me with getting practical experience on my project. Her discussions and corrections have greatly improved the quality of my work.

I would like to extend my deepest gratitude, love and affection to my beloved parents, Mahboobeh and Vahid, for loving me, believing in me and wishing the best for me. I owe all my achievements to them and it is to them that I dedicate this work.

Finally, I would also like to thank my beloved wife, Bahareh, for her kindness, care and countless sacrifices. She was a real support throughout my thesis writing.

Last but not least, I would like to share this moment of happiness with my brother, Arashk. May this realization encourage him to pursue his education in medicine and science.

Introduction

Background

Blood consists of:

- Red cells
- White cells
- Platelets
- Plasma¹

Hematopoiesis

Hematopoiesis is the formation and development of blood cells. Sites of hematopoiesis include the bone marrow, liver, spleen, lymph nodes and thymus. The blood cells have the particular ability for persistent production which demands tight regulatory system. Pathological processes interfering with normal production can lead to an excess (hyperplasia; e.g., leukemia) or an inadequate number of cells (hypoplasia; e.g., anemia, thrombocytopenia, or leukopenia).¹

Hematopoietic Stem Cell (HSC)

Hematopoiesis begins at embryonic period when blood islands are formed in the yolk sac in the third week of gestation. Blood islands are the source of primitive blood cells till these cells migrate to liver and spleen. These organs are the main sites of hematopoiesis from six weeks to seven months, when eventually the bone marrow becomes the center of hematopoiesis. After birth, the bone marrow is the only source for production of blood cells and hematopoiesis takes place in the marrow of nearly all bones. Reaching adulthood, hematopoiesis becomes confined to the bone marrow of central skeleton and the proximal

¹ Plasma is the liquid component of blood where blood cells are suspended.

ends of long bones (Figure-1), in which all blood cell types are derived from pluripotent stem cells, termed as hematopoietic stem cells (Figure-2).²

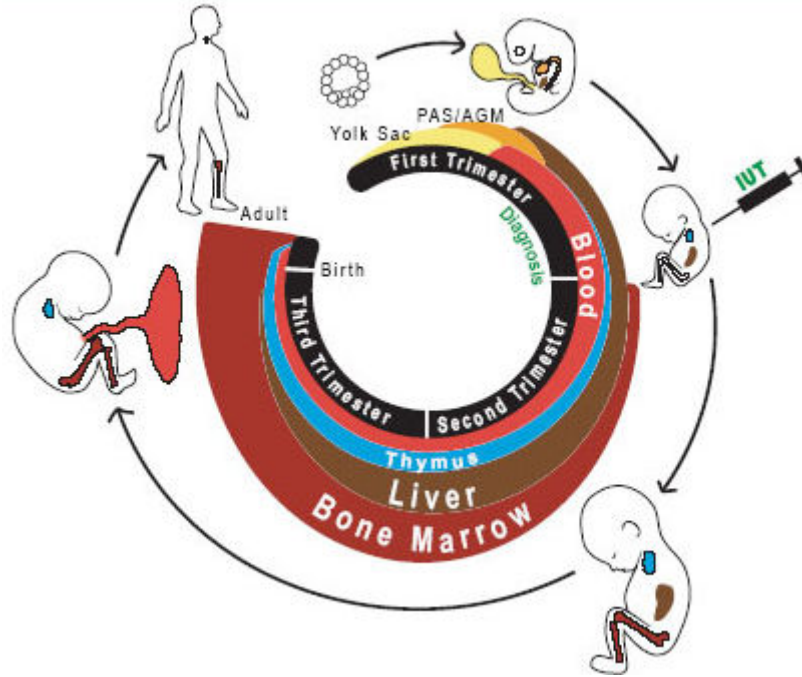

Figure 1- Hematopoiesis in humans. Anatomical location of hematopoiesis change during human development.³

Stem cells have been found in practically every tissue. Like other stem cells, HSCs are characterized by two clonal properties: self-renewal, the hallmark property of stem cells, is the production of more stem cells with the maintenance of an undifferentiated state, and the second is the extensive proliferation and differentiation capacity to generate differentiated progeny to commit to one specific cell line (lineage-specification). Excess or inadequate production of hematopoietic cells will end in various disease states.⁴

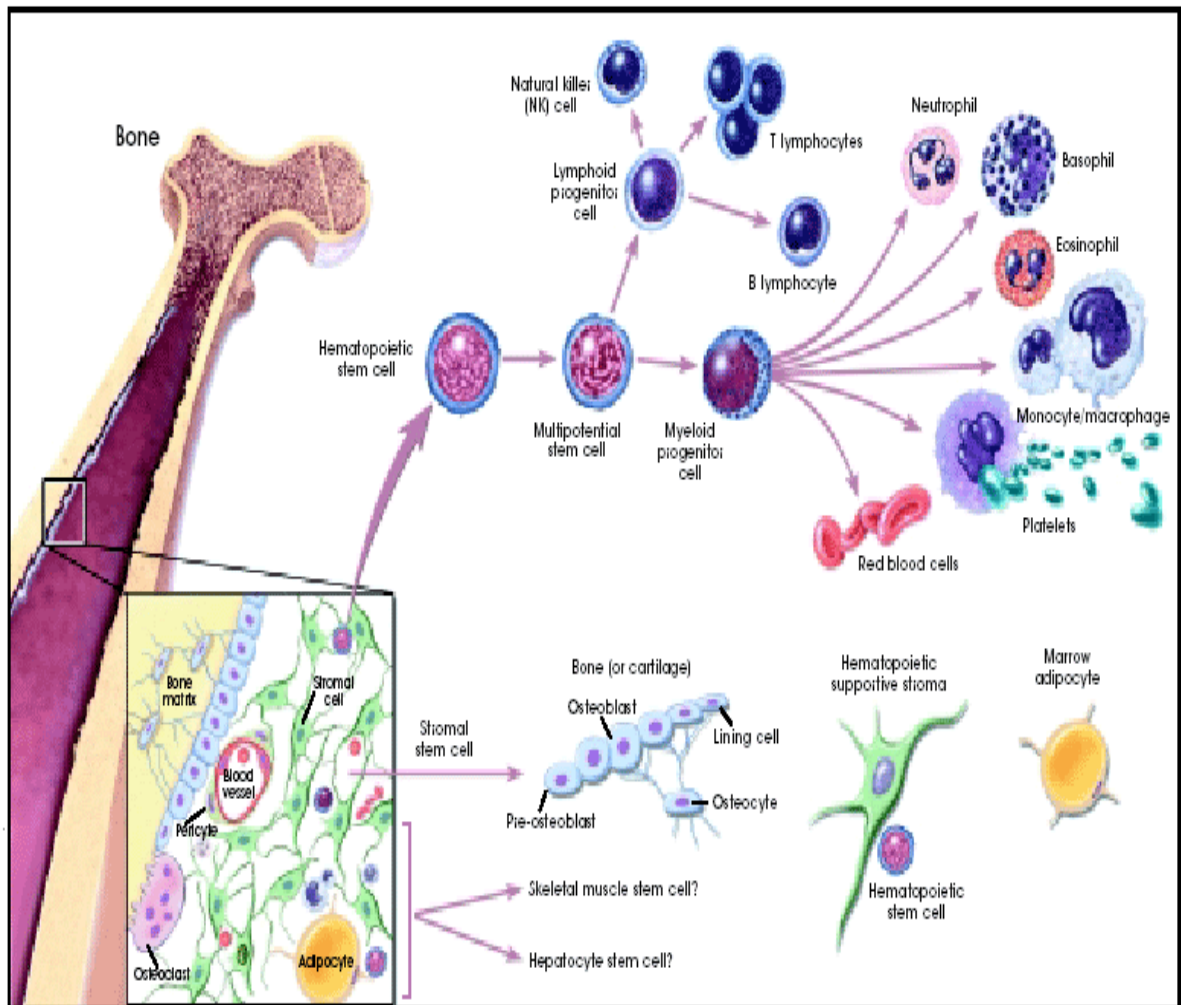

Figure 2- Hematopoiesis and stromal cell differentiation.⁵

Lineage specification of HSCs. HSCs produce a variety of differentiated cell lineages, depending on intrinsic cell programming and the micro-environmental signals.⁶ The stem cell plasticity and lineage commitment are shown to be regulated by a sequential expression of hematopoietic genes and are the result of transcription control in concert with chromatin remodeling and epigenetic modifications. Lineage specification and cellular maturation begins by alteration in cellular gene expression profile, which commits the cell to a specific lineage, and continues by the establishment of lineage-specific gene

expression. All these decisions are entirely made by temporal and spatial activation of certain lineage-specific genes and repression of the others. Commitment to a given lineage is mediated by many ubiquitous and lineage-specific transcriptional regulatory proteins that activate lineage-specific gene expression programs and extinguish expression of lineage-inappropriate genes.^{7,8}

Erythropoiesis

Erythropoiesis is the process of red blood cell (RBC) formation and development. Red cell precursors pass through several stages in the bone marrow to produce mature red cells (erythrocytes). As development progresses, at each stage, cells contain less RNA and more hemoglobin (Hb) in the cytoplasm. The cell becomes smaller, and the nucleus becomes more condensed and eventually is lost, when the cells are released into circulation as reticulocytes. After 1-2 days, reticulocytes lose their RNA and shape into non-nucleated biconcave discs, namely mature red cell (erythrocyte).⁹

Hemoglobin Synthesis

The characteristic red color of blood is from hemoglobin (Hb). Hemoglobin is the main protein in the red blood cells that carries oxygen (O_2) from lungs to the rest of the body and returns carbon dioxide (CO_2) from the tissues to the lungs. This critical performance is governed by the biconcave shape of RBCs, providing a large surface area for oxygen and carbon dioxide exchange, and by high affinity of Hb for oxygen and carbon dioxide in lungs and body tissues, respectively.¹⁰ Hemoglobin is also involved in transportation of a third gas, Nitric oxide (NO), which is important in regulation of blood pressure by vasodilation and increasing blood flow.¹¹

Different types of hemoglobin are produced during development from embryonic period to adult life. Each hemoglobin molecule consists of two α -like (141 amino acids) and two β -like (146 amino acids) chains forming a tetramer. Each globin chain tightly enfolds a non-protein heme moiety in a “pocket”, consisting of a single iron atom (Fe^{2+}) at

the center held in a heterocyclic protoporphyrin IX ring with an optimal position for reversible oxygen binding. Four molecules of oxygen can therefore bind to and be transported by one hemoglobin molecule.¹²

The “blueprint” for hemoglobin synthesis exists in two tightly linked loci, α -like globin genes clustered on chromosome 16^{II} and the β -like globin genes clustered on chromosome 11, with four genes encoding each polypeptide chain during development (Figure-3).¹³

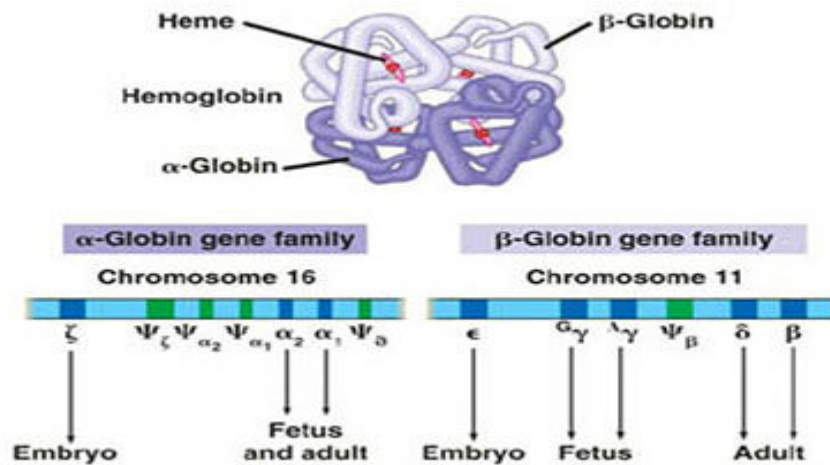

Figure 3- Hemoglobin structure. hemoglobin is a hetero-oligomeric protein contains two α and two β subunits arranged with a quaternary structure.¹⁴

At least six different types of hemoglobin molecules are formed, in steps, following the sequential expression of α - and β -globin gene clusters in process of human development (Figure-4). Hb A ($\alpha_2\beta_2$) is the major hemoglobin in adults with about 97% while two other types, Hb A2 ($\alpha_2\delta_2$) and Hb F ($\alpha_2\gamma_2$), are found only in small amounts, 1.5-3.2% and <1%, respectively. HbF ($\alpha_2\gamma_2$) predominates during most of gestation period.¹⁵

^{II} The α -like cluster consists of two α -globin genes and a single copy of the ζ gene. These genes are similarly arrayed in the order that they are expressed during ontogeny.

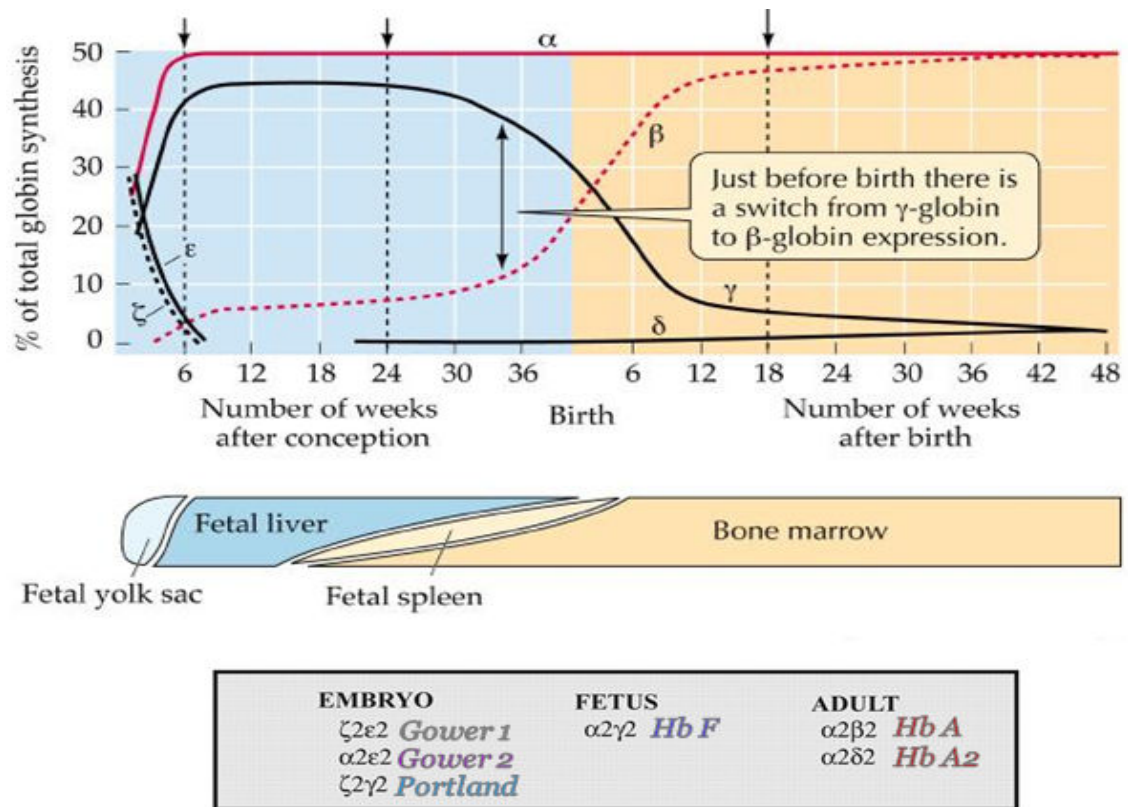

Figure 4- Types of normal hemoglobin. Different normal hemoglobin variants involve genes both from the alpha and beta gene clusters. Hemoglobin A ($\alpha 2\beta 2$) is the normal hemoglobin that exists after birth. Hemoglobin A2 ($\alpha 2\delta 2$) is a minor component (< 3%) of the hemoglobin found in red cells after birth. Hemoglobin F ($\alpha 2\gamma 2$) is the main hemoglobin during fetal development.¹⁶

Hemoglobinopathies

Hemoglobinopathies, hemoglobin disorders, are genetic defects that results in qualitative (sickle cell disease) or quantitative (thalassemias) change in the hemoglobin molecule.¹⁷

Thalassemia. Thalassemia is a hereditary underproduction of either the alpha or beta globin chains of the hemoglobin molecule resulting in a hypochromic, microcytic anemia. Gene deletion results in variable levels of disease. There are four genes coding for

the alpha chain of hemoglobin. There can be deletions of one, two, three or all four genes. Beta thalassemia can be mutated in either one or two genes.¹⁸

The clinical presentation of these disorders is dependent on the number of abnormal genes. In alpha thalassemia one gene deleted yields a normal patient. Individuals with two genes deleted have a mild anemia while those with three genes deleted have more profound anemia where beta chains form tetrads, namely hemoglobin H. Four-gene-deleted alpha thalassemia patients die in utero secondary to gamma chain tetrads called hemoglobin Barts. In one-gene-deleted beta thalassemia (thalassemia minor, thalassemia trait), there is a mild anemia with marked microcytosis. Patients with thalassemia major are homozygous for mutations of both genes coding for the beta hemoglobin gene. These patients with beta thalassemia major, also known as Cooley anemia, become severely symptomatic starting at six month of age when the body would normally switch from fetal hemoglobin to adult hemoglobin. They show severe symptoms of growth failure, hepatosplenomagaly, jaundice, and bony deformities secondary to extramedullary hematopoiesis. Later in life, they are symptomatic from hemochromatosis, cirrhosis, and congestive heart failure from chronic anemia and transfusion dependence. In beta thalassemia, there is an increased level of hemoglobin F and A₂. Those with alpha thalassemia will have normal amounts of hemoglobin F and A₂.

Thalassemia trait of both the alpha and beta types do not require specific treatment. Beta thalassemia patients require blood transfusions once or twice a month accompanying with iron chelating therapies with Deferasirox as the standard of care.¹⁹ A small number of patients can be treated with hematopoietic cell transplantation.²⁰

Sickle Cell Disease. Sickle cell disease is an autosomal recessive hereditary disease. Hemoglobin S is due to a substitution of a valine for glutamic acid as the sixth amino acid of the beta globin chain. Almost all of those with the trait are asymptomatic. Those with sickle cell disease (SS) typically have mild to moderate anemia with irreversibly sickled cells and recurrent painful crises. Elaborate therapeutic modalities are beyond the scope of

what is neither necessary nor relevant to know for this thesis. Bone marrow transplantation can be curative but still be considered experimental at this time.²¹

Human β -globin locus

The human β -globin locus consists of five functional genes; ϵ , $G\gamma$, $A\gamma$, δ and β , organized in the order of their developmentally timed expression^{III} (Figure-5). These genes reside within ≈ 50 kilobases (kb) of chromosomal DNA in the transcriptional activation during ontogeny and are expressed in cells of erythroid cells.²² Important regulatory sequences flank each gene: promoter elements at immediate upstream, and enhancers as well as silencers located in vicinity or at distance in the locus.²³ Transcription of the β -globin locus undergoes two sequentially programmed switching during development from ϵ to γ at six weeks of gestation and from γ to δ/β shortly after birth.²⁴

A powerful set of enhancer elements, namely β -locus control region (β -LCR), exists at 5' upstream of ϵ gene. Human β -globin LCR consists of five developmentally stable, DNase I hypersensitivity sites (HSs) and is located 6-30 kb upstream of the ϵ gene^{IV}.²⁵ Susceptibility to digestion with DNase I indicates that these regions are, in fact, accessible to transcription and chromatin remodeling factors at the time of gene expression.²⁶ The enhancer activities of 5'HS2, 3 and 4 resides in core elements (200-300 bp) of individual HS sites composed of a wide array of binding sites for ubiquitous and lineage-specific transcription factors. 5'HS1-4 are erythroid-specific and 5'HS5 is ubiquitous.²⁷ Another HS site (3'HS1) is located downstream of the β -gene. Two additional HSs (5'HS6-7) have also been discovered at the 5' end of the β -globin domain (Figure-5).²⁸

^{III} A non-expressed pseudogene ($\psi\eta$) is also located on human β -globin locus.

^{IV} The LCR was first identified in the human β -globin locus, being important in the control of eukaryotic gene expression in many other mammalian gene systems.

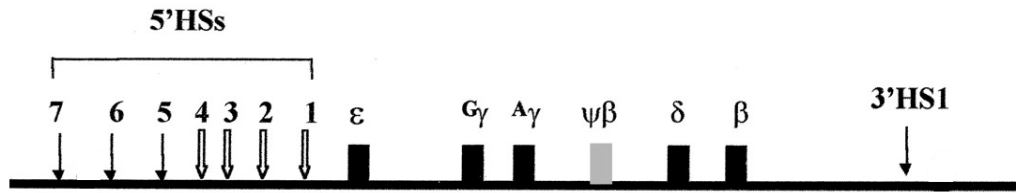

Figure 5- Structure of human β -globin locus.

The spatial arrangement of β -globin genes with respect to LCR is essential for their proper regulation throughout development; i.e. the genes expressed early in embryonic stage are closest to the LCR and those expressed in adult life are farthest.²⁹ LCR enhances the expression of β -like genes to physiological levels in a tissue-specific and copy number-dependent manner.³⁰

Globin gene expression. It is well known that globin gene expression is restricted to specific tissues. Recently, the thought that globin gene expression is solely confined to erythroid cells is questioned by findings of adult hemoglobin protein in activated macrophages and alveolar epithelial cells. However, these cells have shown lower amounts of globin polypeptides, comparing to erythroid cells, and different gene regulation mechanisms.³¹ Further studies are yet required to elucidate the patterns and mechanisms of hemoglobin expression in these cells during cellular differentiation and under various environmental conditions. Moreover, mechanisms required to preclude globin gene silencing in alternative hematopoietic lineage are poorly described.

Considering the hematopoiesis tree, the transcription of the β -globin locus is exclusively displayed by erythroid cells, and more importantly, results in erythroid-lineage specification. Normal red blood cell differentiation requires the coordinated expression of erythroid-specific genes, such as the globin genes and the genes responsible for heme and iron metabolism. These processes are under the control of and involve the complex interplay of a number of specific growth factors and cytokines such as interleukins, granulocyte-monocyte-stimulating factors (GM-CSF), stem cell factor (SCF) and

erythropoietin (EPO).³² For instance, erythropoietin, a glycoprotein hormone produced by the kidney, promotes red blood cell survival through protecting these cells from apoptosis.^{33,34} Also, in the hematopoietic system, stem cell generation, cell fate decisions and maintenance (lineage-specification and commitment) and differentiation depends on the coordinate activity of multiple transcription factors through transcription factor networks interacting with crucial regulatory regions of lineage-specific genes.^{35,36} That is the promise of differentiation towards the production of erythroid-lineage versus non-erythroid cells.

Globin gene expression and LCR

Temporal and spatial control of gene expression are mediated by binding of *trans*-acting factors to *cis*-acting DNA sequence(s) such as promoters, enhancers, and silencers as well as long-range *cis* regulatory LCR elements.³⁷ The LCR was first identified in the human β -globin locus over 20 years ago.³⁸ While different in composition and location, mammalian β -globin loci of different species, including humans, mice, rats, rabbits, and goats contain LCR in part of their genome.^{39,40}

In human β -globin locus, the regulation of gene expression is achieved by the dynamic interactions between *cis*-acting sequences and *trans*-acting factors. Proximal and distal *cis*-acting sequences, the LCR and downstream globin gene sequences, establish and maintain specific chromatin conformations. *trans*-acting factors, transcription factors, coregulators and chromatin remodeling factors, initiate, regulate and determine the final level of gene expression control.⁴¹ Modulation of chromatin structure can have opposite effects on gene regulation as activation versus repression.⁴² Dynamic chromatin configuration as open, resulted from histone modification (histone acetylation), or closed chromatin, due to DNA methylation and histone deacetylation, is quite central to tissue-specific developmental control of β -globin gene expression.⁴³ In general term, the open chromatin is defined as DNase I-sensitive and hyperacetylated state of histone composing the chromatin, whereas closed chromatin is DNase I-insensitive and underacetylated. Such

chromatin structure fluctuation between “open” and “closed” conformations is mediated by chromatin-remodeling complexes that are concomitantly associated with both LCR and β -like globin promoters to facilitate interactions between transacting factors and DNA. Chromatin remodeling complexes modulate chromatin structure to promote binding of erythroid-specific and ubiquitous transcription factors at both LCR and the gene promoters. Such modulations assist the assembly of the transcription apparatus required for full level of expression in erythroid cells while accompanies inactive chromatin structure in non-erythroid cells. These complex interactions determine the transcriptional status as well as the final level of β -like globin gene expression.^{44,45}

While located at a considerable distance from the site of transcription initiation, LCR controls the overall level of expression of β -globin genes as a key regulator of the locus chromatin organization. Chromatin is in "open" state at LCR throughout development but its state at β -globin genes is determined by the expression order of target genes during ontogeny; that is open at ϵ -/ γ -globin domain during embryonic/fetal period but closed during adult erythropoiesis. The reverse state exists for adult δ -/ β -globin domain.⁴⁶ LCR role in chromatin-opening and in maintaining of an open chromatin state is essential for recruitment of additional chromatin remodeling factors, necessary for further opening of chromatin, or of other transcription factors, involved in high level of expression.⁴⁷

Several models have been proposed to elucidate how the LCR exerts its regulation on transcription from such a long distance. From four most prevalent models proposed for LCR function^V, looping model is more acceptable to explain the mechanisms underlying the LCR interaction with the globin genes. All these models indicate that LCR alters chromatin configuration. The looping model implicates that LCR loops back on itself to fold into a “holocomplex” without straining the backbone bonds of the DNA double helix. More significantly, this allows the locus to form a spatial conformation and take hold of a physical close proximity to the desired gene, which facilitates the interaction of

^V These four models are looping, tracking, facilitated tracking and linking models.

transcription factors bind to LCR with those at promoters. This proximity secures the interaction of LCR-bound transcription factors and/or coactivators with basal transcription factors bound at the promoter.^{48,49}

Data from studies on some forms of thalassemia^{VI} containing deletion in LCR region have supported the indispensable role of LCR in expression of β -globin genes. While these forms of thalassemia carry intact β -globin locus, globin genes are not expressed. These deletions result in closed chromatin configuration of globin locus, normally opened by LCR, and thus the suppression of gene expression occurs. These natural occurring deletions of the LCR such as in Hispanic thalassemia, provide the evidence that the LCR is critical for the chromatin organization of the locus.⁵⁰

The presence of LCR for globin gene expression is important since its absence shuts down β -globin gene expression to less than 1%. The most prominent property of the LCR is strong transcription-enhancing activity. However, not all HS sites have the same importance in this respect. The main enhancer activity is conferred by 5'HS2, 5'HS3, and 5'HS4, and not 5'HS1 or 5'HS5.⁵¹ The interaction of regulator transcription factors with LCR HS sites and with each other is essential for high-level of globin gene expression at different developmental stages.⁵² Deletion of the HS core element from 5'HS2, 3, or 4 abolishes normal LCR function due to disruption of the DNase I-hypersensitivity sites holocomplex and preclude proper interaction with promoters but when there is no position effect, the disruption of one HS does not impair the other HS site formation.⁵³ Even the orientation of LCR HS elements is central for proper functioning; that is, a synthetically inverted LCR has been associated with low level of globin gene expression throughout development. This suggest that The LCR transcription enhancer activity is directional.⁵⁴ At any specific stage of hematopoietic cell differentiation, different transcription machinery complex is stabilized on LCR, according to transcription factor milieu, whereby an enhancement in globin gene expression is achieved. The LCR, similar to globin genes, has

^{VI} Hispanic β -thalassemia

tissue-specific enhancing activity which more specifically confines the expression of globin genes to erythroid cells. In essence, developmental and lineage-specific regulation of gene expression results from the complex interaction of gene-proximal elements with distant *cis*-regulatory elements on a bed of chromatin.

Globin gene expression and transcription factors. Complex genetic programs determine survival, proliferation, differentiation and function of hematopoietic cells during different steps of hematopoiesis. Gene expression is controlled at various points between the translation of DNA to proteins with transcriptional control be the most important point of regulation for many genes. Gene transcription is possible only when DNA-binding proteins come together, assemble and interact with the promoters, the operators and the enhancers. The existence of multiple regulatory regions and varied DNA-binding proteins helps a given gene to precisely control its expression at a basal level and/or up- or down-regulate the expression in response to cellular stimuli for differentiation and/or proliferation. In hematopoiesis, many of these protein complexes are lineage restricted and act as cell type-specific transcription factors.⁵⁵

Globin gene expression is regulated by the dynamic interplay between transcription factors and epigenetic mechanisms. Many transcription factors have been shown to control β -globin gene expression through the formation of intricate transcription factor networks (TFNs) and by binding several *cis*-acting elements on locus, followed by recruitment of additional regulatory proteins (cofactors) via direct protein-protein interactions.⁵⁶ General transcription factors (GTFs)^{VII} and different lineage-specific transcription factors should bind the promoter and LCR of β -genes to mediate the tissue- and stage-specific expression of the β -like globin genes. Some of these factors are ubiquitous (e.g., Sp1 and YY1), while others are tissue-restricted and more or less limited to erythroid cells (e.g., GATA-1, NF-

^{VII} GTFs or basal transcription factors are proteins that either bind DNA or take part in the formation of a preinitiation complex (PIC), and used by RNA polymerase II to begin and proceed with transcription. The most important GTFs are TFIIA, TFIIB, TFIID, TFIIE, TFIIF and TFIIH.

E2, TAL-1 and EKLF). These transcription factors turn on/off the transcription appropriately to fit the gene-expression profile for cell fate determination and cellular differentiation. It is becoming increasingly clear that these factors do not operate independently but as part of large multi-protein complexes.⁵⁷

Given the formation of large multiprotein complexes, certain transcription factors can engage in functional interactions, via these complexes, while lacking sequence-specific activity. Indeed, a single transcription factor can employ numerous mechanisms to control transcription and thus, one cannot consider the function of a particular hematopoietic transcription factor independent of complex partners and apart from important functional interplays. Herein, it is unfeasible to comprehensively review all transcription factors implicated in erythropoiesis, but short recapitulation of some potential lineage-specific transcription factors would be relevant for our study.

Transcription factors and Erythropoiesis (Table-1)

GATA-1 is a master regulator gene critical for erythroid cell formation.⁵⁸ It interacts with several transcription factors; CBP/p300, PU.1, Sp1 and erythroid Kruppel-like factor (EKLF), through different multiprotein complexes to activate adult β -like globin genes.⁵⁹ The PU.1-GATA-1 interaction⁶⁰ and the balance between GATA-1 and GATA-2 levels are required for precise lineage specification.⁶¹ While GATA-1 expression is observed in erythroid, mast cell, and megakaryocyte lineages, GATA-2 is expressed in certain hematopoietic precursors and is crucial for the survival and proliferation of HSCs.⁶² During erythropoiesis, GATA-1 level increases and displaces GATA-2 on hematopoietic target genes so that different genes expressed in accordance with GATA switch.⁶³ Such GATA switch is facilitated in virtue of friend of GATA-1 (FOG-1) activity. FOG-1 is a protein whose expression mimics that of GATA-1 and is essential to stimulate erythropoiesis.⁶⁴ FOG-1 helps GATA-1-mediated looping by which LCR comes close to adult β -globin genes.⁶⁵ In addition, PU.1 antagonizes GATA-1 DNA binding and thus blocks

erythropoiesis in favor of granulocyte and monocyte, B and T lymphocyte differentiation. The antagonistic interaction of GATA-1 and PU.1 drives hematopoiesis via common myeloid progenitor (CMP) cells into granulocyte macrophage progenitor (GMP) cells or megakaryocyte erythroid progenitor (MEP). While sufficient levels of PU.1 will produce GMP lineage, higher levels of GATA-1 (comparing to PU.1) will moves differentiation to MEP. Also, GATA-1 exists in a multiprotein complex called SCL complex with LMO2, E47 and Ldb1 in different hematopoietic cells at distinct stages of hematopoiesis.⁶⁶

Stem cell leukemia (SCL), also known as T-cell acute lymphocytic leukemia-1 (TAL-1), belongs to class II HLH proteins and has tissue-restricted and lineage-specific patterns of expression.⁶⁷ TAL-1 is known to be essential for haematopoiesis. The TAL-1 gene is normally expressed in haematopoietic progenitors, erythroid lineage cells, mast-cell lineage cells, megakaryocytic lineage cells and endothelial cells.⁶⁸ TAL-1 dimerizes with E proteins (E47) and functions at multiple stages of hematopoiesis. SCL complex binds a composite motif consisting of a GATA motif and an adjacent E-box.⁶⁹ SCL also stimulates the generation of hemangioblasts to differentiate into both blood and endothelial cells.^{70,71}

Alteration in TFNs or dysregulation of signaling and transcriptional function leads to neoplastic transformation of hematopoietic cells and consequently the progression of specific leukemias. In the same way, the genes responsible for heme and iron metabolism ought to specifically be expressed during erythropoiesis to conform to RBC differentiation.⁷²

Transcription Factor	Gene	Function
GATA-1	GATA-1	Erythroid and Megakaryocytic development
Erythroid Krüppel-like Factor (EKLF)	EKLF	Maturation of erythroid cells, Chromatin remodeling, Modulation of the gamma to beta globin switch, Transcriptional activation, Binding to the CACC motif of the β globin gene promoter
Nuclear factor erythroid-derived 2 (NFE2)	NFE2	Interaction with CREB binding protein
Stem cell leukemia (SCL) or T-cell acute lymphocytic leukemia-1 (TAL-1)	TAL-1	Generation of HSC
FOG-1	FOG-1	Cofactor of GATA-1
p300 and CREB binding protein (CBP)	p300 and CREB	Increase gene expression, histone acetyltransferase (HAT) activity, Recruiting the basal transcriptional to promoter

Table 1- Role of Transcription factors in Erythropoiesis.

Helix-Loop-Helix (HLH) proteins

There are four basic classes of bHLH proteins classified according to their structural motifs. The basic helix-loop-helix (bHLH) proteins are dimeric transcription factors present in nearly all organisms from yeast to humans.⁷³ Numerous bHLH proteins have been identified in animals, plants and fungi. They are first introduced by Murre C, *et al* about twenty years ago.⁷⁴

Helix-Loop-Helix (HLH) proteins: Regulators of transcription in eukaryotic organisms. The fundamental roles of these transcription factors are established in a broad spectrum of cellular and molecular events involved in the regulation of commitment, cell growth and differentiation of various cell lineages during embryonic development, particularly neurogenesis, myogenesis, retinogenesis and hemetopoiesis.⁷⁵ The followings are a few examples: BETA2 (NeuroD1) is a member of bHLH proteins and studies on mouse animal models have shown that it plays an important role in the development of the central and peripheral nervous system.⁷⁶ Muscle Regulatory Factors (MRFs) of the bHLH proteins; MyoD, Myf5, Myogenin and MRF4 are sequentially expressed during skeletal muscle formation and coordinate the expression of muscle-specific genes required for skeletal muscle development in embryo. MyoD and myogenin work as dimmers to drive appropriate myogenesis.⁷⁷ Any of retinal photoreceptor cell lineages carries an exclusive bHLH context during retinal neurogenesis, which highly emphasizes the cell-specific property of bHLH transcription factors.⁷⁸ NeuroD acts as important regulator at some point in rod and cone photoreceptor genesis.⁷⁹

Classification and structure. bHLH transcription factors bear sequence homology, with overlapping and analogous expression patterns, and highly conserved DNA binding specificity. Members of this family contain two highly conserved domains at either end. N-terminal (AD1 domain) is a basic DNA binding domain that helps the transcription factor to bind to DNA at a consensus hexanucleotide sequence of G(orA)CAXXTGG(orA), namely

E-box. At the C-terminal (AD2 domain), there is HLH dimerization domain which is involved in formation of hetero- and homo-dimers with other members of bHLH family.⁸⁰ Figure-6 shows the structure of MyoD that stands up for the feature structure of many bHLH proteins consisting of two amphipathic long α helices connected by a short loop that mediates homo- and heterodimerization.

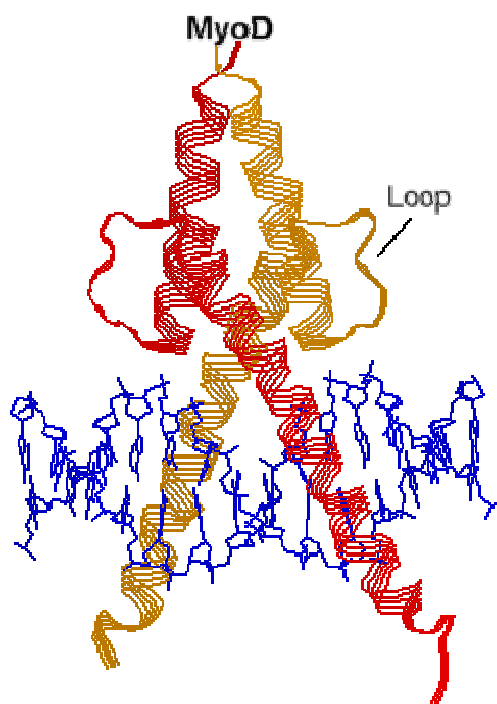

Figure 6- Structure of a MyoD basic-helix-loop-helix (bHLH) transcription factor.⁸¹

The phylogenetic classification of bHLH proteins as four groups of proteins named A, B, C and D is illustrated in Table-2.⁸² The bHLH proteins can show ubiquitous (E47, E12, HEB and E2-2) and tissue-restricted (MyoD and neuroD) expression. Class I bHLH proteins (E proteins) are comprised of four members encoded by three distinct genes: E2A (E12 and E47 known collectively as the E2A proteins)^{viii} encoded by Tcf2a gene through different splicing, E2-2 and Hela E-box binding protein (HEB). The two former has

^{viii} Synonyms are Immunoglobulin Transcription Factor-1 (ITF1) and Transcription Factor-3 (TCF-3)

different DNA binding affinity with higher affinity for E47. HEB and E2-2 show similar DNA binding activity.⁸³ The variety in tissue distribution, DNA-binding characteristics and the capacity for homo/hetero dimerization provide bHLH with high functional diversity and specificity. Moreover, the transcriptional activity of the bHLH proteins are modulated by Id^{IX} (inhibitor of differentiation) proteins which in turn confers far more functional diversity with respect to the formation of inactive heterodimers that inhibit bHLH proteins from binding to the E-box sites and activating gene transcription.^{84,85}

Classification of bHLH proteins by sequence

Phylogenetic group	Description	Classification according to Murre <i>et al.</i> [12]	Examples of classified proteins (family names)
A	Bind to CAGCTG or CACCTG	I, II	MyoD, Twist, Net
B	Bind to CACGTG or CATGTTG	III, IV	Mad, Max, Myc
C	Bind to ACGTG or GCGTG. Contain a PAS domain		Single-minded, aryl hydrocarbon receptor nuclear translocator (Arnt), hypoxia-inducible factor (HIF), Clock
D	Lack a basic domain and hence do not bind DNA but form protein-protein dimers that function as antagonists of group A proteins	V	ID
E	Bind preferentially to N-box sequences CACGCG or CACGAG. Contain an orange domain and a WRPW peptide	VI	Hairy
F	Contain an additional COE domain, involved in dimerization and DNA binding		Coe (Col/Olf-1/EBF)

Table 2- Classification of bHLH proteins.

^{IX} Id proteins are helix-loop-helix (HLH) proteins consist of four isoforms (Id1, Id2, Id3, and Id4), with homologous HLH domain, that lack the DNA binding basic domain. Id proteins regulate cell type-specific gene expression during cell proliferation, differentiation and commitment, cell cycle, and apoptosis. Acting as negative regulators of bHLH transcription factors, Id proteins are considered as dominant negative regulators of differentiation pathways.

E proteins and hematopoiesis. Multiple basic helix-loop-helix (bHLH) genes play a critical role in regulation of hematopoietic cell proliferation and differentiation. The function of E proteins in lymphocyte development and differentiation, and their role in lymphoma development is addressed on a large scale, but very little is known yet about the mechanisms through which E proteins may contribute to myeloid lineage specification, and particularly erythropoiesis. Functional heterodimers between the E proteins and other tissue-specific bHLH regulators have been observed. E proteins bind to E-box motif (NNCANNTGNN) on their target genes as either heterodimers with Class II bHLH proteins in non lymphoid cells or homo/hetero dimmers in lymphoid cells.⁸⁶

E proteins in lymphoid-lineage. Research on E proteins has identified that the E proteins contribute to B lineage- and T lineage-specific gene expression programs by which they regulate lymphocyte survival and cellular proliferation. The expression of several lymphoid lineage-specific genes is regulated through different types of hetero/homodimers, of which the presence of E2A is indispensable.⁸⁷ E2A drives HSCs to the establishment and generation of early B cells by activating B cell-specific gene expression programs and immunoglobulin heavy chain (Igh) gene rearrangement. The function of E2A proteins as transcriptional activators is imperative for the completion of immunoglobulin gene rearrangement and normal lymphoid cell development.⁸⁸ In E2A knockout mice, B-cell development between the pre-B and pro-B-cell stages, at the pro-pre-B stage before expression of the IL-7Ralpha, and the rearrangement of the immunoglobulin genes are severely disrupted.⁸⁹ Other studies have revealed complete B cell development block in E2A-deficient mouse models.⁹⁰

In B-cells, E proteins mainly exist as E47 homodimers, or as E47/E12 heterodimers associated with HEB. HEB and E2-2 are necessary for formation of pro-B cells while interacting with E2A. That is to say E2A is necessary for B lymphoid commitment while for further proliferation and differentiation HEB, particularly, and E2-2 are required at later

stages.⁹¹ Latest data from generation of double-deficient pre-B cell lines for E2A and HEB proteins have confirmed these findings.⁹²

Directly relevant to above enquiries, the role of the E proteins E2A and HEB during T lymphocyte development have been well established. Different combinations of bHLH proteins; SCL, E2A and HEB, control the regulation of T-lineage, non-T-lineage and cell cycle genes at each stage of T-cell development by activating or repressing receptor-dependent signals.⁹³ E proteins are expressed all over the stages of T cell development and their effects are counteracted by Id proteins to adjust the stepwise transcriptional control required for lymphopoesis.^{94,95} E47 and E12 proteins are important for early thymocyte development and similar to the role they perform in B-lineage development, the loss of E2A gene activity, in E2A gene-null mice, gives rise to a partial block at the earliest stage of T-lineage development and consequently to development of T-cell lymphoma.⁹⁶ Similarly, any disruption in HEB expression results in partial block in T-cell development.⁹⁷

E proteins and ETO family. Transcriptional repression plays a critical role in development and homeostasis likewise. Besides the formation of heterodimers with inhibitory Id proteins, E proteins can show repressive effects on gene expression through the recruitment of different co-regulatory factors to the AD domains. For instance, in mammalian cells, AD1 can either activate transcription through recruitment of the histone acetyltransferases CBP and p300 or repress transcription by direct recruitment of ETO family.^{98,99,100} E2A activity is inhibited by Id2 through its interaction with E47 DNA binding domain and also by repression E47 target gene through the interaction of its N-terminal domain (AD1 domain) with ETO-2.^{101,102} Id proteins show inhibitory effects on both positive and negative regulatory properties of E proteins and consequently end in repression or activation respectively, whereas ETO members might only drive transcriptional repression.

The ETO family is comprised of three highly conserved and ubiquitously expressed transcriptional regulatory proteins encoded by three genes in the mammalian genome: eight twenty-one (ETO; MTG8), myeloid transforming gene related protein-1 (MTGR1) and myeloid transforming gene chromosome 16 (MTG16; ETO-2). Three closely-related murine homologues include mETO, cbfa2t3 (murine homologue of MTGR1) and ETO-2. ETO-2 is highly identical to MTG16 suggesting ETO-2 as a murine homologue of MTG16. Mouse ETO is 75% identical to ETO-2 and 99% identical to human ETO. These proteins interact with a number of transcription factors inside the different multiprotein repressor complexes and on the promoters of different target genes.¹⁰³

ETO gene products can interact with both nuclear corepressors N-CoR and Sin3A, and histone-modifying (chromatin remodeling) proteins histone deacetylase 1 (HDAC-1) and histone deacetylase 3 (HDAC-3).¹⁰⁴ N-CoR, mammalian Sin3 (mSin3A and B) work in concert with HDAC-1 to modify the chromatin structure in favor of transcriptional repression.¹⁰⁵ ETO has received a large attention because the hybrid gene product (AML/ETO), resulting from the translocation of AML (CBF2) gene on chromosome 21 and the ETO (MTG8/CDR) gene on chromosome 8, forms a fusion oncoprotein which is associated with leukomogenesis and is found in French-American-British (FAB) type M2 acute myeloid leukemia (AML).¹⁰⁶ The proposed explanation for underlying mechanism is directly relevant to ETO function as a compelling transcriptional repressor within and in interaction with the N-CoR/mSin3/HDAC-1 complex. AML1/ETO fusion may inhibit expression of AML1 target genes by redirecting aforementioned repressors, hence could inhibit cellular differentiation and disrupt normal hematopoiesis. This HDAC-dependent transcriptional repression ensues in a variety of hematologic lineage-specific gene promoters and turns out to be a common pathway in the development of leukemia.¹⁰⁷

Data regarding the role of E proteins in erythroid lineage is still limited. Recently, Goardon N, *et al.* has shown that, in erythroid cells, E2A, HEB and E2-2 are within the SCL (TAL-1) complex containing ETO-2, HDAC-1 and HDAC-2.¹⁰⁸ The function of TAL-

1 complex is seminal to the regulation of hematopoietic specific genes from HSCs to differentiated hematopoietic progenitors in both mouse and human and also for differentiation to lymphoid or myeloid progenitors.¹⁰⁹ TAL-1/E2A as well as TAL-1/HEB heterodimers play important roles in transformation of T-cell precursors.¹¹⁰

TAL-1 may act as a bifunctional transcriptional regulator (activator and repressor) depending on transcriptional coregulators (coactivators or corepressors). TAL-1 is involved in a complex transcription network bearing either repression or activation capacity for genes whose promoters occupied by TAL-1, E2A, and HEB. E2A, HEB and TAL-1 protein levels and their relative ratio as well as their stage-specific transcriptional partners alter during hematopoiesis and consequently the expression of their target genes are adjusted and lineage-specific gene expression programs are controlled. TAL-1 can either form a heterodimers with E2A and HEB proteins, which prevents E2A to form homodimers necessary for transcription activation, or recruit other transcriptional repressors. This repression effect is proposed as one of the several mechanisms involved in leukomogenesis (T-ALL^X).¹¹¹ In hematopoietic progenitor cell lines, TAL-1 interacts with ETO-2 through E2A/HEB where ETO-2 is recruited on its target promoters via this complex. SCL complex gene expression profile is repressed by ETO-2 at the early stage of erythroid differentiation and restores, later in process of cellular maturation, by changing in the ratio of TAL-1. During erythroid differentiation, the relative ratio of TAL-1/ETO-2 rises in favor of TAL-1 that reduces the inhibitory effect of ETO-2 over the expression of TAL-1-dependent erythroid-specific genes.¹¹² A recent study showed that, upon the induction of murine erythroleukemic (MEL) cells and subsequent to detachment of ETO-2 complex from Ldb1 complex^{XI} the level of ETO-2 decrease which leads to induction of differentiation and termination of proliferation (Figure-7).¹¹³

^X T cell Acute Lymphoblastic Leukemia

^{XI} Ldb1 forms a protein complex with TAL-1, E2A, HEB and Lmo2.

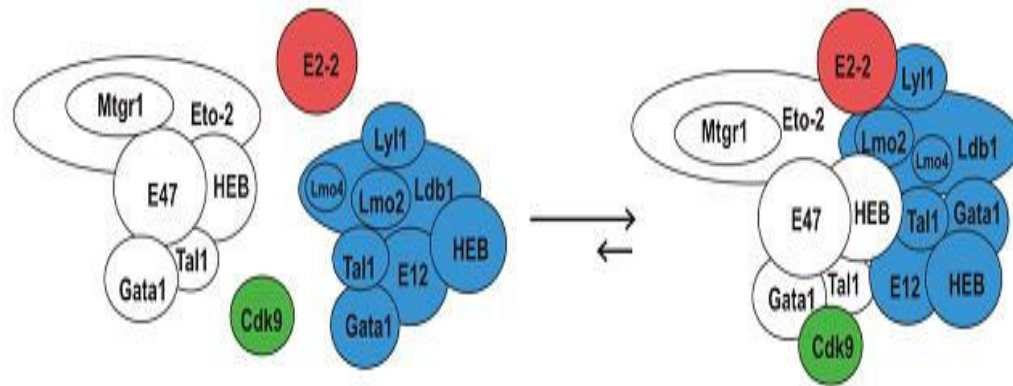

Figure 7- Model of Ldb1 complexes in uninduced MEL cells. The horizontal arrows indicate that the balance of interaction is towards the large complex in proliferating noninduced cells. Upon the induction of differentiation and termination of proliferation the level of Eto-2 drops whereas the level of Lmo4 rises, hence the equilibrium would shift towards the smaller complexes. The presence of several DNA binding proteins in a single complex may explain the role of Ldb1 as a facilitator of long-range interactions.

Taking together, the fluctuation in concentration of transcription factors and/or their cofactors as well as their relative ratio can influence the final composition of protein complexes recruited to gene regulatory regions and therefore play a cause-and-effect relationship in expression of erythroid genes and in making decisions on differentiation versus proliferation.

Further to clear information from prior studies on animal models and considering the insurmountable limitations to the direct experimentation one can perform in human populations, the mouse modeling is most effectual to understand the mechanisms involved in β -globin gene expression. This study is expected to provide insight into epigenetic regulation of β -globin locus during erythropoiesis and help to understand how gene expression is regulated in the context of chromatin. Once DNA regions subject to transcription factor recruitment are identified, changes in transcription factor networks within these sites will be examined in reference to globin gene expression. Herein, we attempt to define the affect of bHLH transcription factors on potentiation and basal level expression of globin gene in hematopoietic progenitor cells and on high level expression in

erythroid cells. In an attempt to investigate the whole β -globin locus, the strategy of present project is to focus primarily on HS2, HS3 and promoters of γ -and β -globin genes as these regulatory regions are highly essential for expression of globin genes. By this, we would reemphasize the harmonizing role of LCR and promoter regions in gene expression. Once the components of transcription machinery are identified, we visit knock-out studies, using HEB^{-/-} and E2A^{-/-} mouse models transgenic for β -globin locus, to validate our findings. This study is designed to deliver an answer to address the molecular mechanisms associated with epigenetic modification and transcriptional activation of the β -globin locus and is a continuation of what we have been doing orientated in alternative lineage.

Applications of study

Molecular application. Understanding the molecular mechanisms that control globin gene expression during development provides us with great insights into basis of epigenetic states acquired at multiple levels and shows how they impact globally on gene expression. This project will enhance our knowledge about the mechanism of globin gene expression. Research in this field has an impact on understanding the basic concepts and principles of regulatory mechanisms that coordinately ensure a highly specialized, tissue- and stage-specific gene transcription pattern in other loci. This study could broaden the horizons of eukaryotic gene regulation as new molecular mechanisms will be discovered and existing ones better characterized.

Clinical application. Molecular investigations of spatial and temporal events that control β -like globin gene expression during erythropoiesis would define many basic mechanisms underlying or relevant to the pathophysiology of hemoglobinopathies, such as sickle cell disease and thalassemia, where the expression of globin genes is disrupted, and would eventually lead to development of molecular therapies and/or cures. For instance, mutations in strategic regions of genes encoding such transcription factors could serve as insults responsible for development and clinical outcome of hemoglobinopathies and become in a position of novel targets for gene therapy in future.

Research Proposal

Rational

The stepwise establishment of lineage-specific gene expression profiles, during the development of mature blood cells of distinct lineages from HSCs, which progressively restrict the differentiation potential and escalate the proliferation potential, makes hematopoiesis an exceptional model system to study TFNs modulating the expression of lineage-specific target genes (Figure-8).¹¹⁴ The human β -globin locus is a highly

characterized locus to study the molecular mechanisms of enhancer-promoter interactions and to elucidate cell type-specific and developmental-stage specific regulation of gene expression. E-box sequences, which are potential binding sites for the bHLH proteins, are scattered throughout the β -globin locus within transcriptional regulatory regions at HS core elements of 5'HS2 and 5'HS3 as well as promoters of γ - and β -globin genes.¹¹⁵ For this reason, these elements are theoretically able to recruit various bHLH proteins and their cofactors in the erythroid environment. The animal modeling provides a powerful tool to directly test the effects of bHLH proteins recruitment to LCR and promoters of γ - and β -globin genes on globin gene expression and to determine the mechanisms of these effects. Once such mechanisms have been delineated, one can return to human studies to confirm key components.

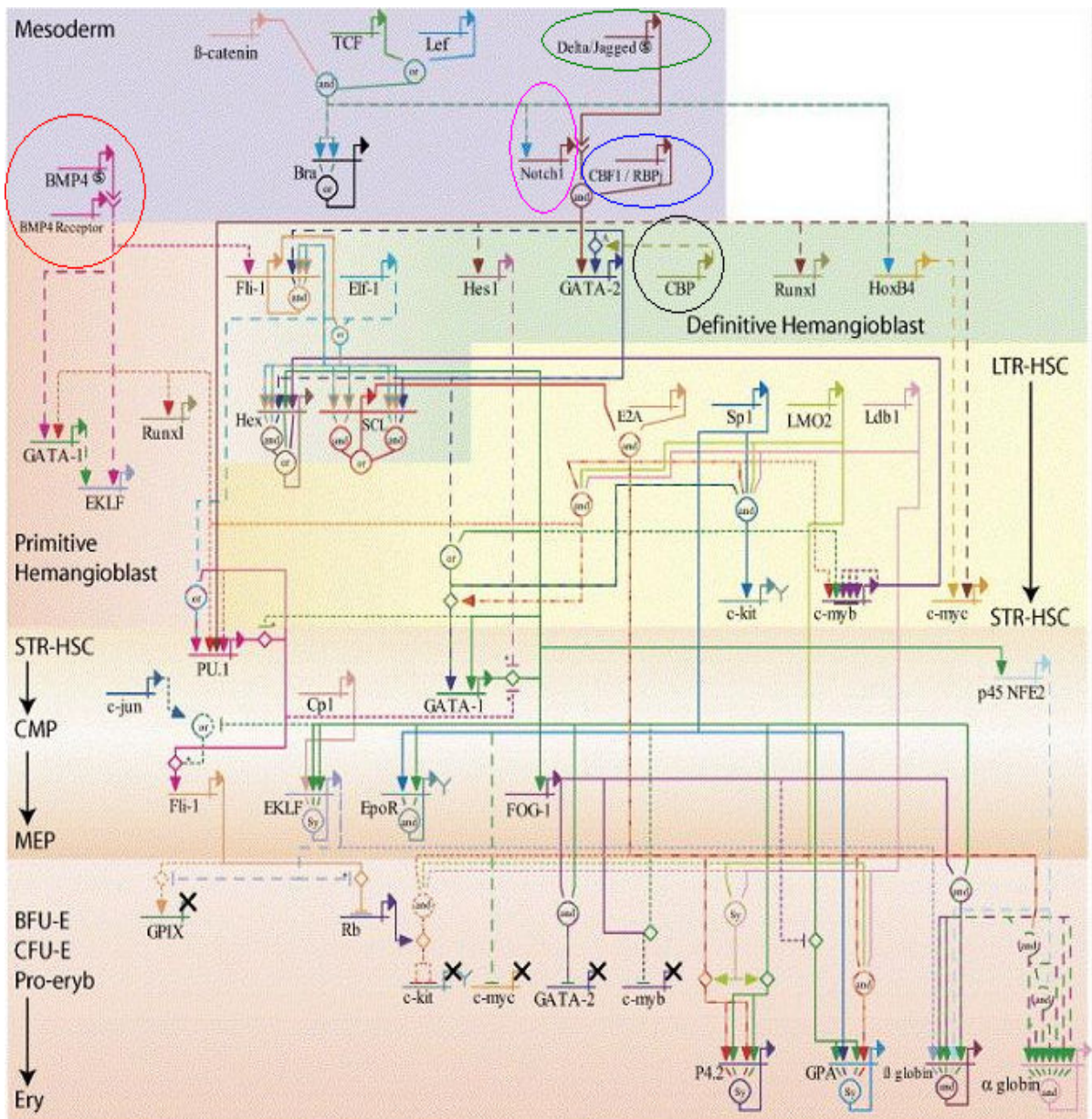

Figure 8- Genetic regulatory networks (GRNs) programming hematopoietic stem cells and erythroid lineage specification. A control logic model of erythroid development describing known interactions important in the development of the erythroid lineage. The genes have been positioned in the network so that genes expressed at early developmental stages are positioned towards the top of the figure and vice versa. Genes repeated in the network in different positions highlight the different behavior important at different stages.

Hypothesis

The prevailing hypothesis is that human β -globin locus potentiation and basal-level of globin gene expression in multipotent hematopoietic progenitor cells (HPCs) and high-level of globin gene expression in erythroid cells are the results of both chromatin modifying activities and the recruitment of general and lineage-specific transcription factors. Informed by key roles of the bHLH transcription factors in lymphoid lineage-specific gene expression, we hypothesized that they could regulate the expression of globin genes in HPC and erythroid cells as well. We hypothesized that E proteins are recruited to both LCR and promoters of γ - and β -genes during the development from HPC to erythroid cells alternating with recruitment of ETO-2 and HDAC-1. We also hypothesize that the absence of E2A and HEB can affect the transcription (*a*) through the changes in involved transcription factors and/or (*b*) through the disruption of gene expression. These hypotheses will be tested mainly by performing Chromatin Immunoprecipitation (ChIP) assay on different sorted populations of hematopoietic cells harvested from wild-type, transgenic and knockout mouse models that carry the entire human β -globin locus in their genome.

Objectives

The prime objective is to answer the questions, "Are E2A and HEB are components of lineage-specific transcription factors recruited to LCR and promoter of globin genes?" and "How these transcription factors are important in terms of globin gene silencing in HPCs, high level of globin gene expression in erythroid cells and in alternative lineages and how their recruitment change during erythropoiesis?", using animal models. The project aims to investigate the major regulatory sites within the β -globin locus that are occupied by E proteins during erythropoiesis in mouse models of human β -globin. With this study we aimed to demonstrate the complex system underlying β -globin gene expression with respect to E2A, HEB, ETO-2 and HDAC-1. Our results would stand as an important step towards gaining a full understanding of processes involved in gene expression.

1. To investigate whether E2A, HEB, ETO-2 and HDAC-1 are recruited to LCR and promoters of γ - and β -genes in murine erythroid cells and hematopoietic progenitor cells (HPCs) as well as human erythroid cells.
2. To explore how the arrangement of these factors changes during erythropoiesis.
3. Following the experiments on normal genetic background, we extend our range of inquiry in knockout mice for E2A and HEB and transgenic for the entire human β -globin locus (E2A^{-/-} β ^{+/+} and HEB^{-/-} β ^{+/+}), respectively. A key question is whether removal of E proteins (E2A and HEB) activity might lead to change in the transcription factor complexes at LCR and globin gene promoters, particularly in reference to ETO-2 and HDAC-1, and/or be disruptive to expression of globin genes. This will enable us to take advantage of mouse genetics to further assess the transcriptional changes at the levels of progenitors and mature red cells.
4. Questions persist as to whether the absence of globin gene expression in lymphoid lineage could to some extent be due to different factors engaged at LCR and globin gene promoters, in which all or none of E2A, HEB, ETO-2 and HDAC-1 factors may be present. We extend our findings by similar exploration of LCR and promoters of γ - and β - genes in lymphoid progenitor cells (LPs) in transgenic mice with wild-type genetic background.

Materials and Methods

Mouse models

Line 2 mouse. The mouse model we used is called line 2 (ln2) which is a transgenic mouse for the entire human β -globin locus. This line maintains strong and consistent expression of human globin genes and the mice thereof express β -globin genes normally: the human transgene is expressed in all murine erythroid cells and each cell that contains mouse β -major globin mRNA also contains human β -globin mRNA. This model was previously described by Milot E, *et al* and Strouboulis J, *et al*.^{116,117} ln2 mice were maintained from homozygous breeder line, available in Dr. Eric Milot's laboratory, born to homozygous mothers crossed with homozygous fathers.

(E2A +/- ln2 +/+) and (HEB +/- ln2 +/+) mice. Most of both E2A knockout and HEB knockout mice die within the first two weeks after birth.^{XII 118} Homozygous mutant mice for E2A and HEB (E2A +/- and HEB +/-) were kindly provided by Dr. Trang Hoang. These mice were crossed with male or female of ln2 +/+ background to produce the ln2 strains heterozygous for the E2A and HEB allele, respectively. After a long process of crossing and breeding, E2A +/- ln2 +/+ and HEB +/- ln2 +/+ mice were obtained by mating males or females with females or males of same genotype. As discussed above, E2A knockout (E2A-/-) and HEB knockout (HEB -/-) genotypes are almost always lethal;¹¹⁹ therefore, E2A- and HEB-null backgrounds would be best investigated as embryos. For this, E2A +/- ln2 +/+ and HEB +/- ln2 +/+ mice were mated with mice of opposite sex and same genotype, then the embryos were extracted out from the mothers after cervical dislocation on gestational day 13.5 (GD13.5, also called 13.5 dpc^{XIII}). After that, fetal livers were extracted and 13.5 dpc fetal liver-derived hematopoietic cells were harvested by flushing the fetal livers. DNA was prepared from a fraction of these cells and used in polymerase chain reaction (PCR) for genotyping to identify those having E2A -/- ln2 + or HEB -/- ln2 + genotype (see Figure 9). With such a cross, the predicted genotype representation for the

^{XII} E2A knockout mice are also born at a lower frequency than wild-type mice.

^{XIII} days post coital

embryos is equivalent for wild-type, homozygous mutant and knockout. The fetal liver erythroid cells (EryC) with E2A $-/-$ In2 $+/+$ or HEB $-/-$ In2 $+/+$ genotype were utilized in the experiments.

Cell Sorting

Staining with antibodies (Abs) was performed on ice for 30 minutes followed by one wash in phosphate-buffered saline (PBS) 5% fetal bovine serum (FBS). High-speed fluorescence-activated cell sorter (FACS) Vantage Flow Cytometer/Cell Sorter machine with Digitalized Vantage (DIVA) option (Becton Dickinson, San Jose, CA) was used to analyze and sort the following desired cell populations. For detection of desired hematopoietic surface markers, the commercial antibodies were purchased accordingly. Nonspecific staining was controlled by isotype-matched control antibodies. Sorted populations were always $\geq 90\%$ pure to perform Chromatin Immunoprecipitation assays.

Murine erythroid cells (Ter-119⁺) and Murine HPCs (Ly-6C⁻CD31^{high}c-Kit⁺)

Bone marrow cells were harvested from the long bones (tibiae, femora) of adult In2 mice. Murine erythroid cells (EryC) were stained with rat anti-mouse Ter119 Abs (TER-119: sc-19592) followed by goat anti-rat phycoerythrin (PE)-conjugated Abs (Santa Cruz Biotechnology, Inc.). For murine HPCs, cells were stained with rat anti-Ly-6C fluorescein isothiocyanate (FITC)-conjugated Abs (ER-MP20: sc-52650) followed by biotinylated rat anti-CD31 (BD Pharmingen: 553371), and then goat anti-rat phycoerythrin (PE)-conjugated Abs (BD Pharmingen), followed by rat anti-mouse c-Kit (CD117) allophycocyanin (APC)-conjugated Abs (BioLegend, Catalog # 105812). The populations of $\geq 90\%$ pure HPCs were separated by FACS.

Murine Lymphoid Progenitors (LPs) ($\text{Lin}^- \text{c-Kit}^+ \text{Sca1}^+ \text{IL-7R}\alpha^+$)

We sorted lymphoid committed progenitor population ($\text{Lin}^- \text{c-Kit}^+ \text{Sca1}^+ \text{IL-7R}\alpha^+$). This population is an highly enriched population of common lymphoid progenitors (CLPs) that also contains other lymphoid progenitors and hereafter referred to as Lymphoid Progenitor (LP) cells.¹²⁰ LPs were isolated via magnetic Lin^+ cell depletion using *EasySep*® negative selection mouse hematopoietic progenitor enrichment cocktail (StemCell Technologies, Vancouver, BC: *EasySep*® Catalog # 19756, *EasySep*® Magnet Catalog # 18000), corresponding to primitive $\text{Lin}^- \text{c-Kit}^+ \text{Sca1}^+$ hematopoietic precursors, followed by $\text{IL-7R}\alpha^+$ selection through staining with CD127 ($\text{IL-7R}\alpha$) antibody (BioLegend, Catalog # 121106) and FACS sorting. 10^8 fresh mononuclear cells were suspended in 1ml PBS containing 2% FBS and 2mM ethylenediaminetetraacetic acid (EDTA). Medium was Ca^{2+} and Mg^{2+} free. Lin^+ cells were isolated inside a standard 12 × 75 mm polystyrene tube placed directly into the magnet, at three steps, firstly by cocktail of biotinylated antibodies, secondly by biotin selection cocktail and then by magnetic microparticles. The desired Lin^- cells were isolated from magnetically labeled unwanted Lin^+ cells remain bound inside the original tube by pouring off the desired fraction into a new polystyrene tube. The purity of these subsets was at least 95%. The lineage restriction and the hematopoietic potential of these cells were ascertained by in vitro clonal assays in methylcellulose culture for at least one representative sorted population. The appearance and distribution of expected colonies and the cellular morphology of this population are described earlier.¹²¹

Human primitive progenitor cells (CD34^+)

Human leukapheresis samples were taken from healthy donors after obtaining an informed consent.¹²² Apheresis procedure is designed to mobilize the hematopoietic progenitor cells in the patient's blood vessels by treatment with G-CSF (granulocyte colony-stimulating factor) cytokine.¹²³ Human CD34^+ cells were isolated using human CD34 positive selection cocktail (StemCell Technologies, Vancouver, BC: *EasySep*®

Catalog # 18056, *EasySep*® Magnet Catalog # 18000). 10^8 fresh mononuclear cells were suspended in 1ml PBS containing 2% FBS and 1mM EDTA. Medium was Ca^{2+} and Mg^{2+} free. CD34^+ cells were isolated inside a standard 12×75 mm polystyrene tube placed directly into the magnet, at two steps, firstly by monoclonal antibodies against CD34 surface antigen and then by magnetic nanoparticles. A total of five rounds of separation in magnet were performed to isolate magnetically labeled (CD34^+) cells from unlabeled cells, by throwing the unwanted population (magnetic nanoparticle-unbound cells) away. To verify the purity of enriched population, the magnetically selected CD34^+ cells were stained with mouse anti-CD34 fluorescein isothiocyanate (FITC)-conjugated Abs (ICO115: sc-7324) (Santa Cruz Biotechnology, Inc.) and analyzed by flow cytometry in FACScan (Becton Dickinson, San Jose, CA). The results were analyzed using the software CellQuest (BD Biosciences). The isolated population was $\geq 98\%$ pure for CD34^+ cells. This population is described previously.

Genotyping

Mice were genotyped by polymerase chain reaction (PCR) using DNA extracted from tail samples. Mouse tails were cut on postnatal day 21 and digested at 56°C overnight in a solution of 50 mM Tris pH 8.0, 100 mM EDTA, 100 mM NaCl and 1% SDS with 100 $\mu\text{g}/\text{ml}$ proteinase K. Tail genomic DNA was prepared through phenol/chloroform extraction. Genotyping was performed using the primers designed to amplify the amplicons from β -globin, E2A and HEB genes. For E2A, the common primer 5'-TTGTGGACATTTTCTAGGCAG -3' was used with either 5'-CCGAGCTCCTTAAAGGCCTCA -3' or 5'-CCGAGCTCCTTAAAGGCCTCA -3' in a separate reaction to detect the mutant allele. For HEB, the common primer 5'-TCCTGCCTAGTAGGGATTTT -3' was used with either 5'-TCTCACTTGCTGTTCTAGAC -3' or 5'-TCGCAGCGCATCGCCTTCTA -3' in a separate reaction to detect the mutant allele. For each genotyping run, known genomic DNA from E2A-null or HEB-null, E2A heterozygote or HEB heterozygote and wild-type

were simultaneously assayed as positive and negative controls. Figure 9 shows one representative example of E2A and HEB genotyping that amplified products were loaded onto 2% agarose gel, stained with ethidium bromide, and directly visualized under UV illumination.

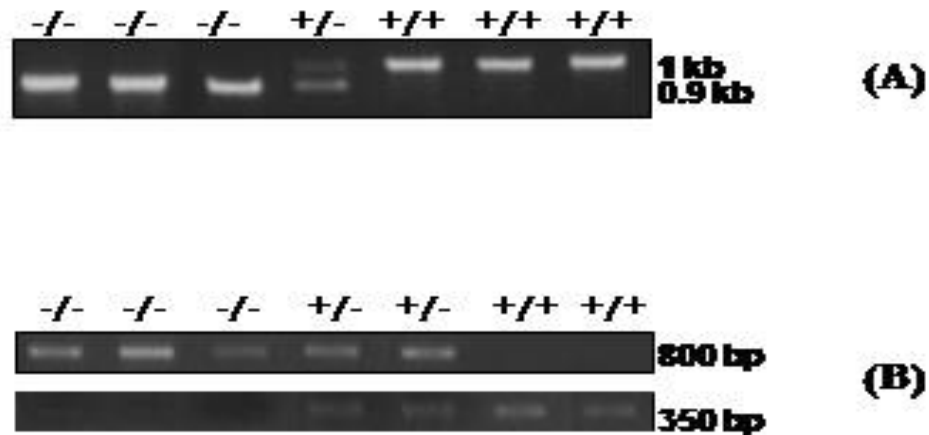

Figure 9- One representative experiment of genotyping (A) E2A and (B) HEB. Ethidium bromide-stained PCR products were separated on a 2% agarose gel.

Chromatin Immunoprecipitation (ChIP) assay

The sorted cell types described above were subjected to Chromatin Immunoprecipitation assay in order to investigate the recruitment of transcription factors of interest to human β -globin locus. ChIP kits (Catalog # 17-295) were purchased from Upstate Cell Signaling Solutions, Lake Placid, NY. Approximately $1.5 - 3 \times 10^5$ (Murine HPCs and LPs) and 10^6 (Murine EryC and Human CD34⁺) cells were used for this procedure. To crosslink the factors with the target genomic DNA, cells were incubated at 37°C for 10 min with 200 μ l of PBS containing 1% formaldehyde. Cross-linked chromatin was sonicated in order to obtain consistent chromatin fragmentations of ~ 500 -bp average for 10 seconds on ice and repeated four times. Sonication was optimized prior to real experiments. A portion of the sonicated lysate without antibody was separated before immunoprecipitation and used as Input chromatin. Following antibodies were raised to

isolate the complex by precipitation: anti-E2A (Yae: sc-416)^{XIV}, anti-HEB (A-20: sc-357), anti-ETO-2 (G-20: sc-9741), anti-HDAC-1 (Catalog # 06-720, Upstate Biotechnology (Lake Placid, NY)), and anti-Histone H3 (di methyl K9: ab7312) (Abcam, Inc., Cambridge, MA). ChIP assays were carried out according to manufacturer's protocol with minor modifications as described previously.¹²⁴ The protein/DNA cross-linked nucleosomal chromatin complex was reverse cross-linked with NaCl at 65°C for 4 hours. Samples were then treated with proteinase-K. DNA was extracted in phenol/chloroform and precipitated and washed in ethanol. On average, 1/30 of each ChIP sample was used in quantitative real time polymerase chain reaction (QRT-PCR). At least three independent ChIP experiments were performed for each transcription factor and the significance of the data was tested according to a student *t*-test.

Real-time Polymerase Chain Reaction (Q-PCR/qPCR)

Real-time quantitative PCR analysis of the immunoprecipitated chromatin was done by the MyiQ thermal cycler (Bio-Rad) based on SYBER[®]Green quantification (Qiagen) according to the manufacturer's instructions. The primer sequences were designed to specifically amplify HS3, HS2, γ - and β -globin promoters using sequence analysis software (DNAMAN). Primer sets were tested to assure an amplification efficiency of 90-105% using appropriate serial 10-fold dilutions of genomic DNA. Threshold cycles (Ct) were determined according to manufacturer software for unbound (input) and for immunoprecipitated chromatin. The occupancy of each region by transcription factor of interest was calculated relative to input chromatin as described by Geisberg JV, *et al.*¹²⁵ Data were presented as fold enrichments over the values obtained for internal control using primer sets specific for the regulatory region(s) (promoter) of mouse THP (kidney-specific Tamm-Horsfall gene) or human pax6 (pax6, paired box protein 6). Each PCR was done in triplicate for each sample, data was calculated using $2^{-\Delta\Delta C_t}$ formula and results were presented as mean \pm SD considering a value of 1 as no enrichment. The amplicons were

^{XIV} Anti-E2A (Yae): sc-416 detects both E47 and E12.

confirmed by a specific melting curve and by the presence of expected band size on the electrophoresis gel and ethidium bromide staining.

Real-time Reverse Transcriptase Polymerase Chain Reaction (RT-PCR)

RNA was extracted from aforementioned number of sorted cells using Trizol Reagent (Invitrogen Life Technologies). RNA was resuspended in 50 μ l of H₂O_{DEPC} and quantified by spectrophotometry. The total cDNA was synthesized from 1 μ g RNA using with oligo(dT)₁₅ primers and SuperScriptTM Reverse Transcriptase enzyme (Invitrogen Life Technologies, Catalog # 18053-017) by incubating for one hour at 37°C, followed by incubation of 15 min 70°C to inactivate the enzyme. The RNA has previously been treated with 1U DNaseI-RNase free, grade amplification (Invitrogen Life Technologies) for each microgram of RNA. cDNA was used in real-time PCR (iCycler iQTM, Bio-Rad) with Qiagen QuantiTect probes specific for human β -globin cDNA (5'-TCGGTGCCTTTAGTGATG- 3' and 3'-TTGCCAGGAGCCTGAA -5'; TET-labeled QuantiProbe: ACCTTTGCCCACTGA; human β RT) or mouse gapdh cDNA (FAM-labeled QuantiTect gene expression assay, Qiagen, GapdRT). To avoid genomic DNA contamination, human β RT and GapdRT primers were designed to span intron-exon junctions. human β RT and GapdRT PCR reactions were independently run at least in triplicate. Quantitative real-time RT-PCR analysis was carried out as described in Bottardi *S, et al.*¹²⁶

Western blot

Prior to CHIP experiments, the specificity of antibodies mentioned above and used against factors of interest were analyzed by Western blotting considering their specific Molecular Weight (MW). The total protein extracts were obtained in sample buffer (100mM Tris pH 6.8, 200mM DTT, 4% SDS, 0.2% Bromophenol blue and 20% glycerol), and then extracts were sonicated twice for 5 sec and boiled for 5 min. The protein extracts were then separated by SDS/PAGE (SDS-polyacrylamide gel 15%), followed by a blotting

onto Hybond ECL nitrocellulose membranes (Amersham Biosciences). The membrane was blocked with skim milk (5% in PBS). The membrane was then incubated for 16 hours at 4°C with the primary antibodies diluted with skim milk (1% in GER) at a concentration of 1: 100. The secondary antibody goat anti-mouse IgG conjugated to peroxidase (Sigma) was diluted with skim milk (1% in GER) at a concentration of 1: 1000 and incubated for 2 hours at room temperature. After each antibody, the membrane was washed three times for 10 min in 0.05% Tween 20 in the TBS. The secondary antibody was revealed with a kit chemiluminescence ECL Plus (Amersham Biosciences), and then hybridized membrane was processed with the phosphoimaging system LAS-3000 (Fuji Life Science) using ImageQuant software. Mouse β -actin housekeeping gene was used on the same blot as a loading control and for comparative estimation of the protein amount applied to the gels. β -actin-specific monoclonal antibody (I-19: sc-1616) was used.

***in vitro* clonogenic assays**

To determine differentiation potential of Murine HPCs, FACS-sorted cells were cultured in Methocult[®] GF M3434 (Stem Cell Technologies, Vancouver, BC, and Catalog # 03434). Single cultures contained 50, 100, or 200 $\text{Ly-6C}^{\text{c}}\text{CD31}^{\text{high}}\text{c-Kit}^{\text{+}}$. The cells were cultured in a humidified atmosphere containing 5% CO₂. Hematopoietic colonies were determined and scored by inverted microscope at three days, for CFU-E (colony-forming units-erythroid) and at 14 days, for BFU-E (burst forming units-erythroid), CFU-G (granulocyte colony-forming units), CFU-GEMM (colony forming units-granulocyte-erythroid-macrophage-megakaryocyte), after the cultures were initiated. To examine lymphocyte colony formation, LPs ($\text{Lin}^{\text{c}}\text{c-Kit}^{\text{+}}\text{Sca1}^{\text{+}}\text{IL-7R}\alpha^{\text{+}}$) were cultured on Methocult[®] GF M3630 (Stem Cell Technologies, Vancouver, BC, and Catalog # 03630) containing rmIL-7 to support growth of pre-B colonies. The colonies were enumerated using an inverted microscope after seven days in culture.

Results

Chapter One

Lineage-Specific Transcription Factors in Multipotent Hematopoietic Progenitors: A Little Bit Goes a Long Way

Bottardi S, Ghiam AF, Bergeron F, Milot E. *Cell Cycle*. 2007 May 2;6(9):1035-9.

Erythroid Krüppel-like Factor (EKLF) is an erythroid transcription factor belonging to the zinc-finger family of DNA binding proteins.¹²⁷ EKLF is essential for the proper maturation of erythroid cells. EKLF knockout mouse are lethal because of anemia resulting from cessation of adult β -globin transcription. EKLF role in β -globin gene expression is mediated by its role in chromatin remodeling, modulation of the gamma to beta globin switch and transcriptional activation of β -globin gene.^{128,129}

This manuscript is the first demonstration that EKLF directly binds the globin locus in progenitor cells. Previously, our group proposed this idea according to the genetic analysis and in this paper, using ChIP assays, our results directly showed the binding of EKLF to crucial regulatory regions on β -globin locus and thus emphasizes its role in β -globin gene expression.

Alireza Fotouhi Ghiam provided and analyzed the data of EKLF and participated in interpretation of results and drafting the manuscript. Some results that were not included in the paper is now provided in supplementary section of this chapter to complete the information on this subject. The importance of these findings is also discussed.

HEMATOPOIESIS AND LINEAGE SPECIFICATION

Hematopoiesis consists in a progressive restriction of cell fate capacities from hematopoietic stem cells (HSCs) to mature blood cells. Lineage specification and cell commitment can be achieved by precise activation and/or repression of specific genes. It is now accepted by most that lineage specification does not depend solely on single master regulators. Rather, it appears to result from precise combinations of specific transcription factors, which cooperate to form the so-called transcription factor network (TFN).^{130 131} TFs that compose the network will act in a concerted way to regulate gene expression, thereby providing cellular identity. A good example of TFN complexity and its impact on lineage specification and cell commitment is the role of Pax5, E2A, EBF, and Ikaros during B lymphopoiesis.^{132 133} Although the underlying mechanisms are not yet fully decorticated, these TFs are known to influence B lymphopoiesis in a highly coordinated manner. Pax5 is expressed at low level in multipotent HPCs¹³⁴ and can activate B lineage specific genes while repressing myeloid genes.^{135 136} For example, Pax5 induces c-fms gene repression by direct interaction and inhibition of PU.1 transcriptional activation.¹³⁷ Another example of alternative lineage suppression¹³⁸ due to direct TF interactions is provided by the interaction of GATA-1 or -2 with PU.1. GATA factors inhibit PU.1 expression and transactivation,^{139 140} and PU.1 acts similarly on GATA proteins (transrepression). PU.1 is essential for myeloid and lymphoid specification, whereas GATA-1 is required for erythroid differentiation. Likewise, PU.1 and C/EBP α antagonize each other during HPCs commitment towards neutrophils or monocytes.^{141 142}

The variable influence that TFs exert on gene expression can be explained by the interplay between TFs and cofactors such as chromatin modifying and/or remodeling proteins. For example, in lymphoid cells, Ikaros can associate with Mi2b, HDAC1 (histone deacetylase 1) and HDAC2, which are components of the nucleosome remodeling and deacetylation (NuRD) complex.¹⁴³ However, in adult erythroid cells Ikaros is part of the PYR complex, which targets to the β -globin locus two types of chromatin remodeling

activities that activate (SWI/SNF, as BAF57, BAF155, BRG1) or repress (NuRD, as HDAC2, Mi-2) gene transcription.¹⁴⁴

Interestingly, also in the same cell type a given TF can function both as an activator and a repressor of gene transcription. This duality is explained by the fact that interactions between lineage-specific TFs and cofactors vary according to the gene regulatory region targeted. For instance, GATA-1 and its cofactor FOG-1, can function as activators at certain gene promoters (α - and β -globin, EKLF, glycophorin A) and as repressors at others (GATA-2, myc, myb) by forming distinct protein complexes. In fact, it is reported that in erythroid cells, the GATA-1/FOG-1/MeCP1 complex represses hematopoietic genes, whereas the interaction between GATA-1 and TAL-1 activates erythroid-specific genes.¹⁴⁵

In addition to the above mentioned, TF protein levels contribute to lineage-specific gene expression. Among others, TAL-1, HEB and E2A protein levels have been shown to fluctuate during hematopoiesis. In hematopoietic progenitors, TAL-1 interacts with ETO2, and via E2A/HEB recruitment, they are both targeted to *gfi-1b*, *p21cip*, and *GPA* promoters.¹⁴⁶ ETO2 recruits several members of the HDAC family and therefore participates in the repression of specific genes including the ones listed above.¹⁴⁷ In hematopoietic progenitor cell lines, *GPA* is poorly transcribed and the TAL-1 complex recruited at *GPA* promoter consists of HEB, E2A and ETO2. During erythroid differentiation, TAL-1, E2A and HEB expression levels increase, thereby is changing the relative ratio TAL-1/ETO2 in favor of TAL-1. This reduces the inhibitory activity of ETO2 and relieves TAL-1-dependent erythroid genes repression.¹⁴⁸ Similarly, in erythroid cells the Ldb1-Lmo2-TAL-1-E2A-GATA-1 complex binds to globin LCR and β -gene promoter.¹⁴⁹ Recently Meier and collaborators¹⁵⁰ have demonstrated that this complex also includes ETO-2 and that upon erythroid differentiation of mouse erythroleukemic (MEL) cells the level of ETO2 and ETO-2/Ldb1 complex decreases, while the level of Lmo-4 increases. They propose that the level of the large Ldb1-ETO2 complex drops to be replaced by one with Lmo-4 to allow late erythroid genes to become activated. Therefore,

relative variations of TFs or cofactors concentration can, by itself, influence the composition of protein complexes recruited at gene regulatory regions and consequently their activating or repressing activities.

POTENTIATION AND GENE PRIMING IN HPCs

In embryonic stem (ES) cells as well as HPCs several lineage-specific genes are located in transcriptionally potent chromatin i.e., chromatin in an open conformation which allows access of TFs and transcriptional machinery to gene regulatory regions. It is in fact proposed that most of the hematopoietic-specific genes are potentiated before their transcriptional activation in mature cells,^{151 152 153} a mechanism that would protect these genes from epigenetic silencing.^{154 155} Gene potentiation has been linked to histone covalent modifications of the locus of interest. For example, a discrete site of the B-cell specific mouse $\lambda 5$ -VpreB1 locus^{156 157} is marked by histone H3 acetylation and lysine 4 methylation (both marks of active chromatin) in ES cells.¹⁵⁸ Similar observations have been made at the human β - (hu β -) globin locus (see below) and at the murine MHC class II locus in multipotent HPCs (Figure 10). According to our recent data, the murine MHC class II locus appears to be potentiated in bone marrow derived common lymphoid progenitor cells (CLP; Lin⁻, IL-7R⁺). More specifically, we assessed histone covalent modifications at DNaseI hypersensitive site 1 and 2 (HS1 and HS2), two of the five HSs forming the MHC class II LCR located 5' to the E α gene. Our results indicate the presence of histone H3 acetylation and lysine 4 (K4) methylation at these regions, suggesting an accessible chromatin conformation and potentiation of the E α gene locus.

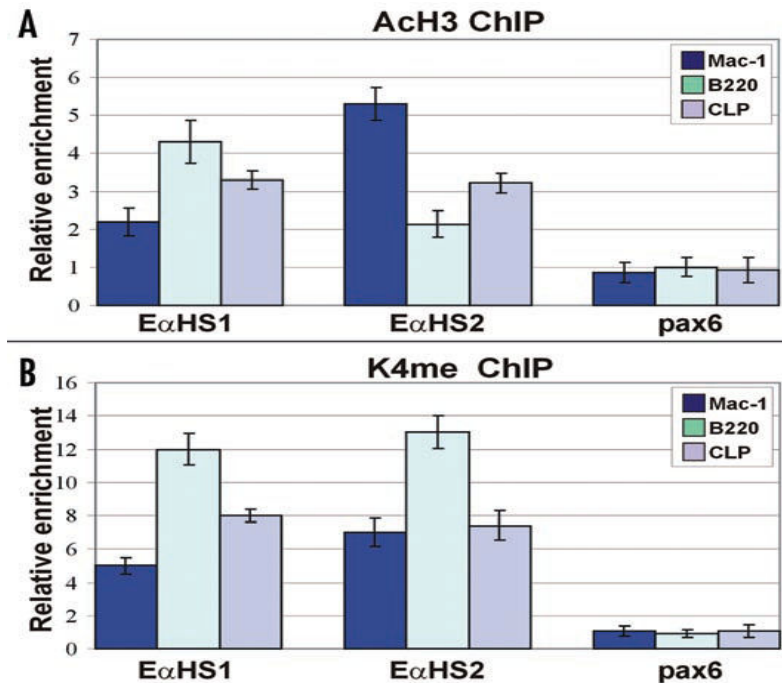

Figure 10- Chromatin immunoprecipitation (ChIP) assays on Mac-1⁺, B220⁺, and common lymphoid progenitor (CLP) cells. Immunoprecipitated and unbound chromatin samples were subjected to real-time PCR with primer set specific for the murine MHC class II locus (EαHS1 and EαHS2) and with another primer set specific for mouse THP (kidney-specific Tamm-Horsfall gene) promoter; pax6 (neural-specific paired box protein 6 gene) promoter is used as a control for ChIP procedure. The level of enrichment (according to the $2^{\Delta\Delta Ct}$ method) of globin regions relative to pax6 and input is shown by bars, with their corresponding standard deviations. A value of 1 indicates no enrichment. AcH3: anti-acetylated histone H3; K4me: anti-lysine 4 methylated histone H3; CLP: common lymphoid progenitor cells (Lin⁻, IL-7R⁺). Further technical details are found in ref. 159.

As mentioned above, the development of more sensitive and accurate techniques has revealed that gene promoters and LCR or LCR-like structures are frequently occupied by lineage-specific TFs in multipotent HPCs. Recently, Anguita and collaborators¹⁶⁰ demonstrated that in a multipotent hematopoietic progenitor cell line, activation of the murine α - globin locus is associated with histone acetylation and with recruitment of GATA-2, NF-E2, and TAL-1 to a LCR-like structure located upstream of the genes (HS-26 and HS-12). Despite the active chromatin conformation and TF recruitment, gene

expression only commences in differentiated erythroid cells, and corresponds to Pol II (RNA Polymerase II) recruitment to gene promoters. Chromatin activation and TF recruitment in primary multipotent HPCs occur in a similar way at the hu β -globin locus, even though in these cells TFs and cofactors are recruited at human β LCR (β LCR) as well as gene promoters, and gene potentiation is associated to basal level of globin gene expression (see below).¹⁶¹ Another example of potentiation and priming in multipotent HPCs is the lysozyme locus, where lineage-specific chromatin alterations can be detected prior to lysozyme transcriptional activation and cell lineage specification in multipotent HPCs.¹⁶² Additionally, chromatin reorganization¹⁶³ and transient interactions with lineage-specific TFs at specific lysozyme regulatory regions have been demonstrated in a multipotent myeloid progenitor cell line.¹⁶⁴

β -GLOBIN GENE POTENTIATION: THE ROLE OF LINEAGE-SPECIFIC TFs

The hu β -globin locus consists of five developmentally regulated genes (ϵ -G γ -A γ - δ - β).¹⁶⁵ Their high-level expression in mature erythroid cells depends on the β LCR comprised of five DNaseI HSs. As expected, HS core regions are rich in hematopoietic and erythroid-specific TF binding sites. In erythroid cells, the β LCR activates transcription through direct interaction with gene promoters and it is a major determinant of locus chromatin conformation.¹⁶⁶ ¹⁶⁷ The β -globin locus has been extensively used as a model to investigate gene regulation in mature erythroid cells. More recently, it has been exploited to understand the mechanisms regulating gene potentiation and priming in multipotent HPCs and during their differentiation towards the erythroid pathway. The first report of globin potentiation dates back to 1992, when Jimenez and collaborators¹⁶⁸ demonstrated that the mouse β -globin LCR is in an open chromatin conformation in murine multilineage progenitor cell lines. Few years later β -like globin genes were shown to be expressed at low levels in hematopoietic progenitor cell lines¹⁶⁹ and in primary HPCs of the aorta-gonad-mesonephros region (AGM).¹⁷⁰

In an attempt to define the mechanisms leading to gene potentiation, we have studied globin potentiation and priming in primary multipotent HPCs of human (CD34⁺ cells) and murine (c-Kit⁺/CD31^{high}/Ly-6C⁻ cells) origin. The latter are cells purified from hematopoietic tissues of a mouse line transgenic for the whole hu β -globin locus (In2). These transgenic mice express the hu β -like globin genes in a developmentally regulated manner.¹⁷¹ We demonstrated that in human and transgenic primary multipotent HPCs the globin locus is in an active chromatin conformation characterized by histone H3 hyperacetylation and K4 dimethylation. Furthermore, we observed that chromatin activation is established and maintained by gene- and developmental-specific patterns of histone covalent modifications.¹⁷² These observations suggest that hu β -like globin genes are independently potentiated in HPCs, presumably through histone modifying activities recruited at specific regulatory regions by lineage-specific TFs. At the time we felt that GATA-1 and NF-E2 were good candidates because they: (1) are erythroid-specific TFs that interact with CBP at the locus;^{173 174} and (2) are expressed at low level in HPCs.^{175 176} Low level expression of lineage-specific TFs in HPCs is known as promiscuous expression since it initially appeared that it did not exert any precise role in HPCs.¹⁷⁷ However, recent observations have led to revisit the role of lineage-specific TFs expressed at low or basal level in HPCs. We have demonstrated that NF-E2, in addition to stabilize CBP binding to the locus in erythroid cells, also plays a pivotal role in globin gene potentiation and priming in HPCs, since CBP recruitment to the hu β -gene promoter is NF-E2-dependent. The erythroid-specific factor EKLF also influences CBP binding to the locus in HPCs, most likely by providing an open chromatin configuration that would support NF-E2 and CBP recruitment. Indeed, EKLF is expressed at low levels in HPCs^{178 179} and, as in erythroid cells, it can interact with BRG1 in the E-RC1 remodeling complex targeting BRG1 to the locus.^{180 181} Accordingly, in HPCs purified from 13.5 dpc (day post coitus) EKLF knockout fetal livers chromatin at and hu β -promoter is not in an active conformation.¹⁸² These results, obtained through a genetic approach, have been confirmed by direct ChIP analysis using antibodies against EKLF (generous gift of S. Philipsen). As shown in Figure 11,

EKLF is efficiently detected at HS2 and HS3 and to the hu β -gene promoter in transgenic (c-Kit⁺/CD31^{high}/Ly-6C⁻ cells) as well as human CD34⁺ multipotent HPCs (supplementary section).

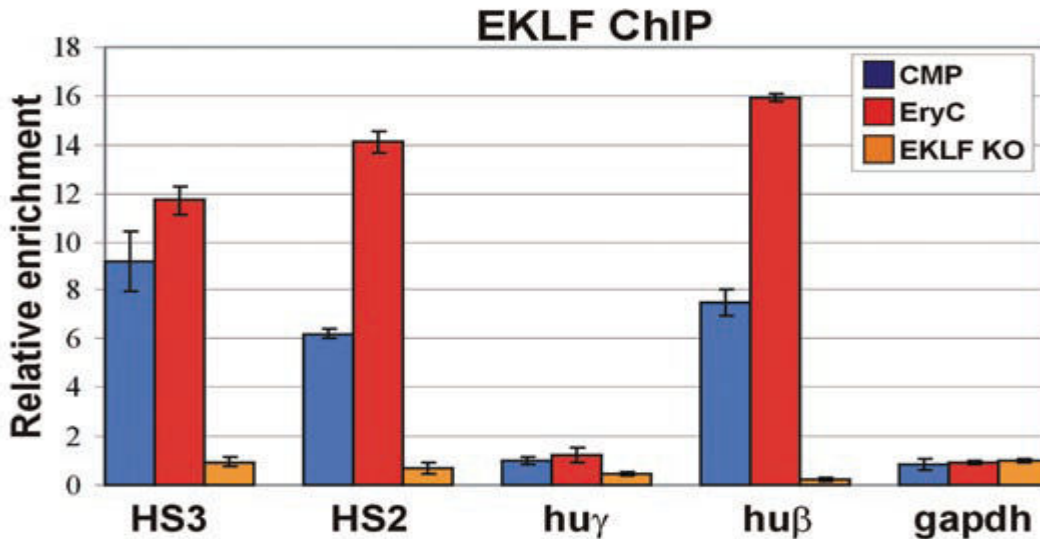

Figure 11- Chromatin immunoprecipitation (ChIP) assays on common myeloid progenitor (CMP), wild type erythroid (EryC), and EKLF knock-out erythroid (EKLF KO) cells. Immunoprecipitated (with antibodies against EKLF, gift of J. Philipsen) and unbound chromatin samples were subjected to real-time PCR with primer set specific for the hu β -globin locus (HS3, HS2, hu γ - and hu β -promoters) and with another primer set specific for mouse THP (kidney-specific Tamm-Horsfall gene) gene promoter; GAPDH promoter is used as a control for ChIP procedure. The level of enrichment (according to the $2^{\Delta\Delta Ct}$ method) of globin regions relative to THP and input is shown by bars, with their corresponding standard deviations. A value of 1 indicates no enrichment. CMP: common myeloid progenitor cells (c-Kit⁺/CD31^{high}/Ly-6C⁻ cells). Further technical details are found in ref. 183.

Altogether, we propose that EKLF is instrumental in hu β -gene potentiation in HPCs. EKLF and BRG1 would promote chromatin remodeling and favors the association of other TFs (such as NF-E2) as well as cofactors (such as CBP) to the globin locus in HPCs. Finally, we have shown that hu β -like globin priming is associated with TBP and Pol II recruitment to and to TBP recruitment to hu β -gene promoter in HPCs.¹⁸⁴ Pol II could not be detected at the hu β -gene promoter even though the hu β -gene is primed in HPCs. This

suggests that Pol II loading at the hu β -promoter is not very efficient in HPCs and it is likely to be the limiting step for high-level globin gene expression such as observed in erythroid cells (Figure 12).

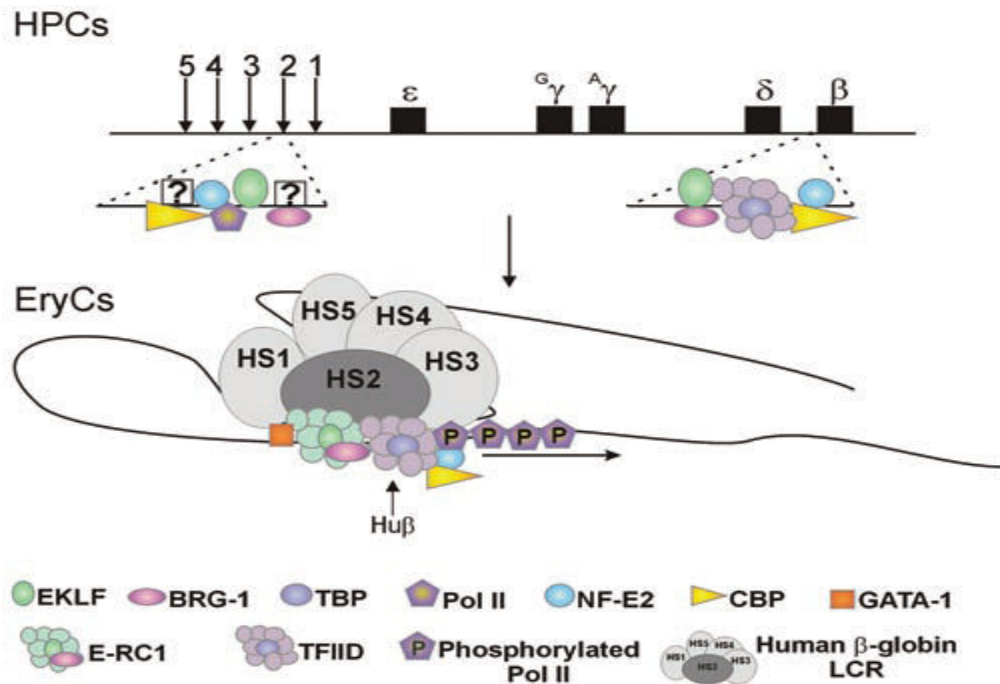

Figure 12- Model of TFs recruitment at the hu β -globin locus in HPCs and EryCs. Schematic representation of TF network at β LCR HS2 and hu β -promoter in hematopoietic progenitor cells (HPCs) and erythroid cells (EryCs), according to our most recent works. Hu β -gene potentiation in 13.5 dpc fetal liver-derived HPCs is associated to NF-E2, EKLf, CBP and BRG1 recruitment to HS2. CBP and BRG1 targeting to HS2 occurs by, thus far, unidentified TFs (indicated by questions marks in the model). NF-E2-CBP and EKLf-BRG1 are also recruited at hu β -promoter, together with TBP, whereas Pol II is detected at HS2 but not at hu β -promoter. In EryC, looping out of intervening chromatin allows HS2 (along with β LCR holocomplex) and hu β -globin promoter to come in close proximity.¹⁸⁵ The E-RC1 complex (constituted by EKLf, BRG1 and other SWI/SNF subunits)¹⁸⁶ further increase chromatin remodeling at both regulatory regions and facilitate the recruitment of other TFs, like GATA-1. Concomitantly, Pol II, transferred from HS2 to hu β -promoter, is efficiently phosphorylated at its C-terminal domain (CTD). Altogether, chromatin remodeling, histone acetylation, and phospho-CTD Pol II recruitment contribute to high-level hu β -gene transcription in mature EryCs.

β -GLOBIN GENE POTENTIATION: THE ROLE OF LCR-LIKE STRUCTURES

Analysis of several loci where gene expression is regulated by LCR or LCR-like structures revealed that most of them are potentiated during early hematopoietic development. General (GTFs) and lineage specific TFs are often bound to LCRs and gene promoters in multipotent HPCs, and as already discussed, some of them have been shown to recruit cofactors involved in chromatin remodeling or histone covalent modifications. This activating mechanism could counterbalance epigenetic silencing therefore allowing a particular locus to be maintained active from HPCs (and probably HSCs) to committed and differentiated hematopoietic cells. Furthermore, probably due to high density of TFs binding sites, LCRs can behave as nucleation centre for assembly of the preinitiation complex (PIC) in order to promote lineage-specific gene potentiation in HPCs and then high-level gene expression in mature cells.^{187 188 189 190}

Investigations made at the β -globin locus support these views since it has been observed that in HPCs the β LCR is capable of recruiting not only GTFs and Pol II^{191 192} but also lineage-specific TFs and chromatin modifying activities.¹⁹³ Previous data from our lab led us to hypothesize that the β LCR is involved in globin gene potentiation in multipotent HPCs.¹⁹⁴ To validate this hypothesis, we have investigated and compared gene potentiation and chromatin activation of the hu β -globin locus in HPCs purified from transgenic mice made either with a wild type hu β -globin locus or with a locus deleted for LCR HS2.¹⁹⁵ Mature erythroid cells isolated from adult hematopoietic tissues of 2B mouse line (containing the hu β -globin locus with a crippled LCR) display PEV (position effect variegation) and only one out of four erythroid cells expresses the hu β -gene even though at normal, high-levels.¹⁹⁶ Since lack of HS2 significantly affects globin gene potentiation and priming,¹⁹⁷ it is highly probable that β LCR dictates general chromatin conformation of the locus and functions as an anchoring structure for GTFs, TFs, and coactivators in HPCs. However, besides the important role of β LCR, we demonstrated that globin promoters are

also critical for gene potentiation and priming in HPCs. In actual fact, in multipotent HPCs, some GTFs and lineage-specific TFs are recruited to globin gene promoters according to their developmental activation (hu β -like globin gene expression is finely regulated during development; particularly γ -globin genes are expressed in fetal life and the β -gene is expressed in adult life).¹⁹⁸ For example, in adult multipotent HPCs EKLF acts as a gene- and developmental-specific TF since it contributes to hu β - but not to hu γ -gene potentiation.¹⁹⁹ In conclusion, it can be assumed that both β LCR and globin gene promoters contribute to gene potentiation in multipotent HPCs. The β LCR would provide a chromatin environment prone to gene transcription and refractory to epigenetic silencing, and it would facilitate PIC nucleation. On the other hand, promoter regions would rather control developmental-specific potentiation and gene transcriptional activation (Figure 13).

CONCLUDING REMARKS

Molecular and biochemical studies have demonstrated that lineage-specific TFs, even when expressed at basal levels in HSCs or multipotent HPCs, can bind to gene regulatory regions like LCRs, LCR-like structures and gene promoters of a variety of hematopoietic loci. From the very early hematopoietic steps, lineage-specific TFs can recruit chromatin modifying and remodeling complexes to gene regulatory regions, hence favoring the recruitment of GTFs and PIC assembly. Therefore, by potentiating lineage-specific gene expression, lineage-specific TFs can influence the identity of progeny cells.

Chapter One

Supplementary section

Human HPCs population (CD34⁺ cells) was purified and enriched from human leukapheresis samples by magnetic positive selection procedure. The phenotypic purity of enriched population was assessed by flow cytometry in FACScan when the magnetically selected CD34⁺ cells were stained with anti-CD34 (FITC)-conjugated Abs. The isolated population was $\geq 96\%$ pure for CD34⁺ cells. Experimental details are depicted in Figure-16 in chapter two of results section.

As shown in Figure 11, EKLF is efficiently detected at HS2 and HS3 and to the human β -gene promoter in transgenic (c-Kit⁺/CD31^{high}/Ly-6C⁻ cells) as well as human CD34⁺ multipotent HPCs (Figure 13).

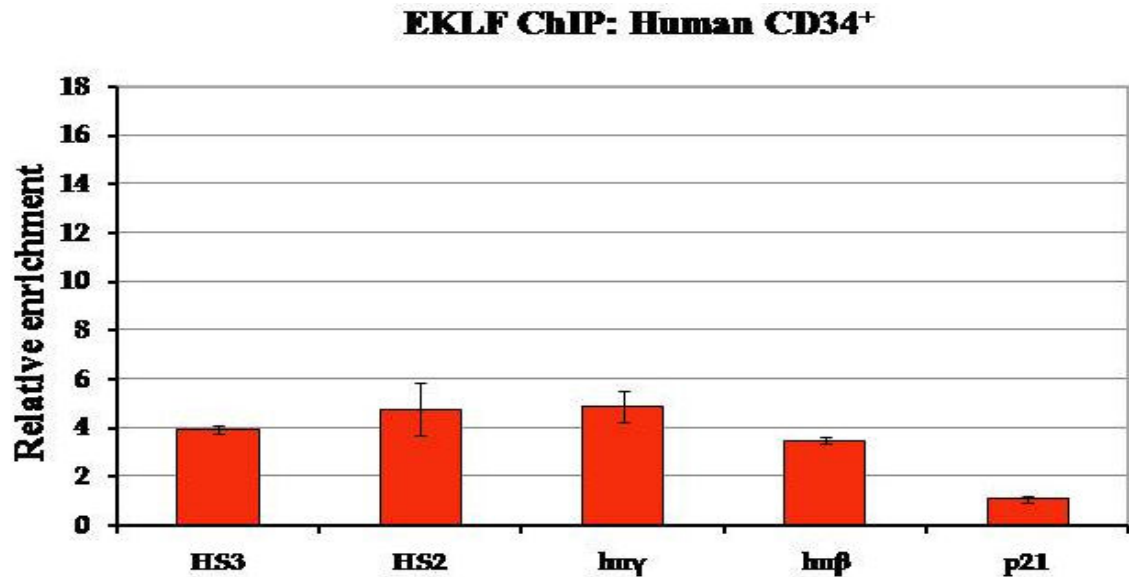

Figure 13- Chromatin immunoprecipitation (ChIP) assays on human CD34⁺ multipotent HPCs cells. Immunoprecipitated (with antibodies against EKLF, gift of J. Philipsen) and unbound chromatin samples were subjected to real-time PCR with primer set specific for the human β -globin locus (HS3, HS2, human γ - and β -promoters) and with another primer set specific for human PAX6 (Paired box gene 6) gene promoter; p21 (Cyclin-dependent kinase inhibitor 1A, also known as CDKN1A) gene promoter is used as a control for ChIP procedure. The level of enrichment (according to the $2^{-\Delta\Delta Ct}$ method) of globin regions relative to PAX6 and input is shown by bars, with their corresponding standard deviations. A value of 1 indicates no enrichment. Each value is the mean \pm SD of at least three independent experiments.

Chapter two

**The basic helix-loop-helix transcription factors E2A and
HEB are involved in globin gene expression**

The animal modeling provides a powerful tool to directly investigate the role of bHLH proteins in the expression of globin genes. We tested the recruitment of bHLH proteins to both LCR and promoters of γ - and β -genes during the development from HPC to erythroid cells and investigate their recruitment considering their interaction with two closely related factors of ETO-2 and HDAC-1. Using the power of mouse genetics, we also investigated the effects of absence of E2A and HEB on the recruitment of these factors to β -globin locus.

Identification of factors bound to the human β -globin locus in erythroid cells and murine HPCs

Murine erythroid cells were isolated from bone marrow of adult mice transgenic for the entire human β -globin locus (In2) using Ter119 antibody. Ter-119 antibody recognizes an epitope on murine erythroid cells at different stages of development, from early proerythroblasts to mature erythrocytes. These cells account for 20-25% of adult bone marrow cells (Figure 14.A) and do not express myeloid or B-cell markers and do not include more developed cells such as BFU-E or CFU-E according to colony assays.²⁰⁰ The purity of sorted population was always $\geq 95\%$ (Figure 14.B). Murine HPCs were isolated from bone marrow of adult In2 mice using Ly-6C/CD31/c-Kit antibodies. Ly-6C⁻CD31^{high}c-Kit⁺ cells sorted by FACS Vantage Flow Cytometer/Cell Sorter machine were cultured onto methylcellulose-based MethoCult[®] M3434 medium for colony-forming cell (CFC) assays to detect and quantify mouse hematopoietic progenitors in bone marrow. Single cultures contained 50, 100, or 200 Ly-6C⁻CD31^{high}c-Kit⁺. Hematopoietic colony types were determined and scored by inverted microscope at three days, for CFU-E and at 14 days, for BFU-E, CFU-G, CFU-GEMM, after the cultures were initiated (Table-3). Phenotypic characteristics of these cells are described previously. These cells (Ly-6C⁻CD31^{high}c-Kit⁺) include about 2% of adult bone marrow cells and are early hematopoietic cells without mature or late-committed properties (Figure 14.C). The purity of sorted population was always $\geq 95\%$ (Figure 14.D).

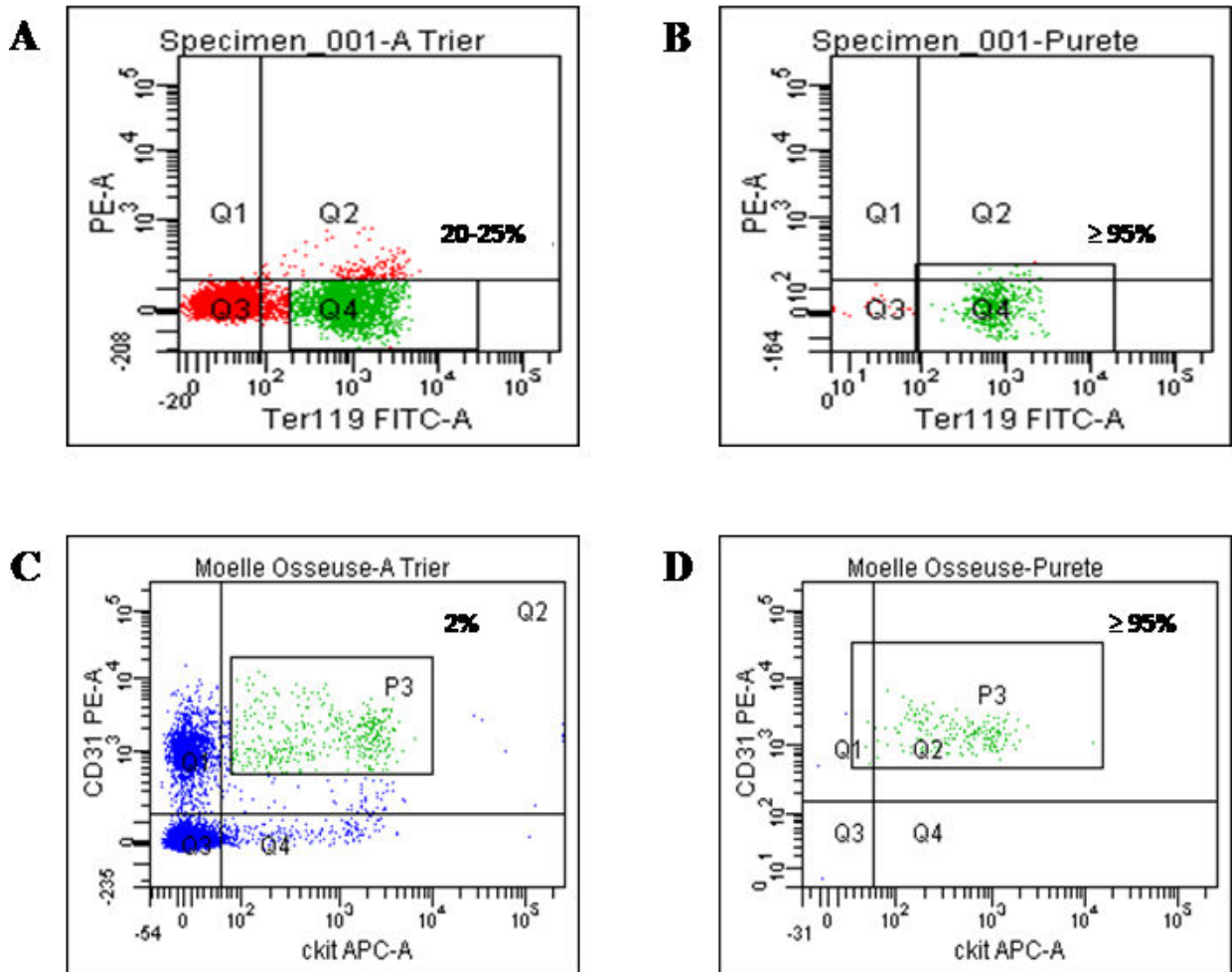

Figure 14- Analysis of hematopoietic cells from ln2 bone marrow mice with Ter119 and Ly-6C/CD31/c-Kit expression. Cells were stained with anti-Ter119 and anti-Ly-6C/CD31/c-Kit antibodies and sorted by FACS Vantage Flow Cytometer/Cell Sorter machine. Results for representative histograms obtained from (A) murine erythroid cells subpopulation (Ter119⁺), representing 20-25% of total bone marrow, and (C) murine HPCs subpopulation (Ly-6C⁻CD31^{high}c-Kit⁺), representing 2% of total bone marrow. Assessment of phenotypic purity of (B) isolated Ter119⁺ fraction after sorting, and of (D) isolated Ly-6C⁻CD31^{high}c-Kit⁺ fraction after sorting. Numbers indicate the percentage of the total cells localized in the indicated quadrants.

To determine if E2A and HEB are directly involved in regulating the β -globin locus, chromatin immunoprecipitation was performed on chromatin prepared from erythroid cells and murine HPCs harvested from bone marrow of adult transgenic mice ln2. CHIP primers

were designed to amplify the HS3, HS2 core regions and promoters of γ - and β -globin genes. As aforementioned, HS2 and HS3 regions as well as promoters of γ - and β -globin genes are crucial *cis* elements regulating the expression of globin genes which theoretically have potential binding sites (E-box) for E2A and HEB. The specificity of antibodies used against E2A and HEB were initially validated in western blot analysis prior to ChIP experiments (Figure 15.A). In both EryC cells and murine HPCs, strong binding of the E2A and HEB to HS3, and particularly to HS2 and β -promoter was observed, which were not affected by differentiation from HPCs to EryC cells (Figure 15.B). The patterns of recruitment were suggesting an increased recruitment of E2A in HPCs and an increased recruitment of HEB in erythroid cells. E2A and HEB binding was not detectable in a comparable site at γ -globin promoter at regions amplified where potential binding site of E2A and HEB (E-box) have been described. ChIP analysis of EryCs and murine HPCs suggests that basal level of β -globin expression in progenitor cells and high level of β -globin expression in EryCs could be mediated through recruitment of E2A and HEB.

To test the hypothesis that the binding of E2A and HEB on globin locus at different stages of differentiation is associated with ETO-2 and HDAC-1 co-factors, we looked at the recruitment patterns at the same crucial regulatory regions of β -globin locus by ChIP assays using anti-ETO-2 and anti-HDAC-1 antibodies. The specificity of antibodies used against ETO-2 and HDAC-1 were initially validated in western blot analysis prior to ChIP experiments (Figure 15.A). In EryCs, HS3 and HS2 regions and the promoter of β -globin gene were identified as positive for both ETO-2 and HDAC-1 binding by ChIP (Figure 15.C). ChIP results showed a marked binding affinity of ETO-2 to β -promoter in HPCs in parallel with reduction in binding in erythroid cells. HDAC-1 was more or less evenly recruited to HS3, HS2 and β -promoter in both EryC cells and HPCs. HDAC-1 was also recruited concurrently onto the γ -promoter, but the binding was weak. These findings suggest that ETO-2 was significantly associated with the β -promoter in progenitor cells and thus repressed the activity of the β -promoter by recruiting transcription repressor HDAC-1.

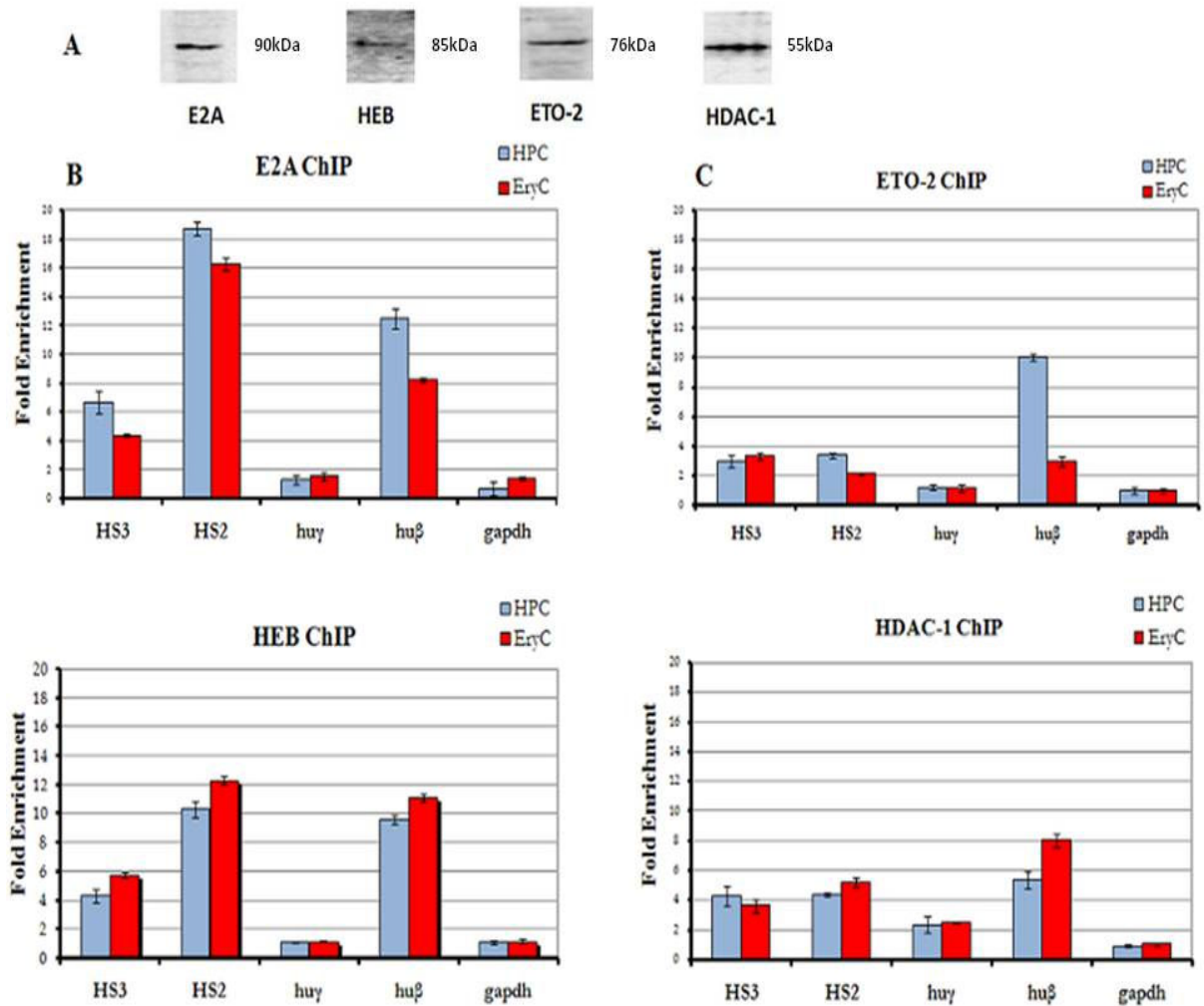

Figure 15- Chromatin immunoprecipitation (ChIP) assays on murine erythroid cells (EryC, Ter119⁺) and murine hematopoietic progenitor cells (HPC, Ly-6C⁻CD31^{high}c-Kit⁺). (A) Western blot analysis of cell lysates from 12.5 dpc fetal liver ln2 wild type cells expressing E2A (90kDa), HEB (85kDa), ETO-2 (76kDa) and HDAC-1 (55kDa) proteins. Immunoprecipitated with antibodies against (B) E2A and HEB or (C) ETO-2 and HDAC-1, and unbound chromatin samples were subjected to real-time PCR with primer sets specific for the human β -globin locus (HS3, HS2, huy- and human β -promoters) and with another primer set specific for mouse THP (kidney-specific Tamm-Horsfall gene) gene promoter; GAPDH promoter is used as a control for ChIP procedure. The level of enrichment (according to the $2^{\Delta\Delta Ct}$ method)²⁰¹ of globin regions relative to THP and input is shown by bars, with their corresponding standard deviations. A value of 1 indicates no enrichment. Each value is the mean \pm SD of at least three independent experiments.

Identification of factors bound to the human β -globin locus in human primitive progenitor cells

Human primitive progenitor cells express CD34 (Cluster of Differentiation 34) and represent 1-3% of total human bone marrow cells. Colony-forming assays have shown that this population includes all bi or unipotent, colony forming units-granulocyte-macrophage (CFU-GM), CFU megakaryocyte (CFU-meg), burst forming units-erythroid (BFU-E) and multipotent progenitors CFU granulocyte/erythroid/macrophage/megakaryocyte (CFU-GEMM) as well as pre-CFU.²⁰² Although several CD34 antibodies are commercially available to isolate CD34⁺ cells from human bone marrow, it is lengthy to separate the 1-3% CD34⁺ cells on the scale required for Chromatin Immunoprecipitation. A simple and rapid method to isolate primitive hematopoietic progenitor cells from bone marrow is to use immunomagnetic cell selection procedure. To enrich for human HPCs, CD34⁺ cells were purified from human leukapheresis samples by magnetic positive selection procedure (Figure 16.A). The phenotypic purity of enriched population (Figure 16.B) was assessed by flow cytometry in FACScan when the magnetically selected CD34⁺ cells were stained with anti-CD34 (FITC)-conjugated Abs (Figure 16.C). The isolated population was $\geq 96\%$ pure for CD34⁺ cells (Figure 16.D).

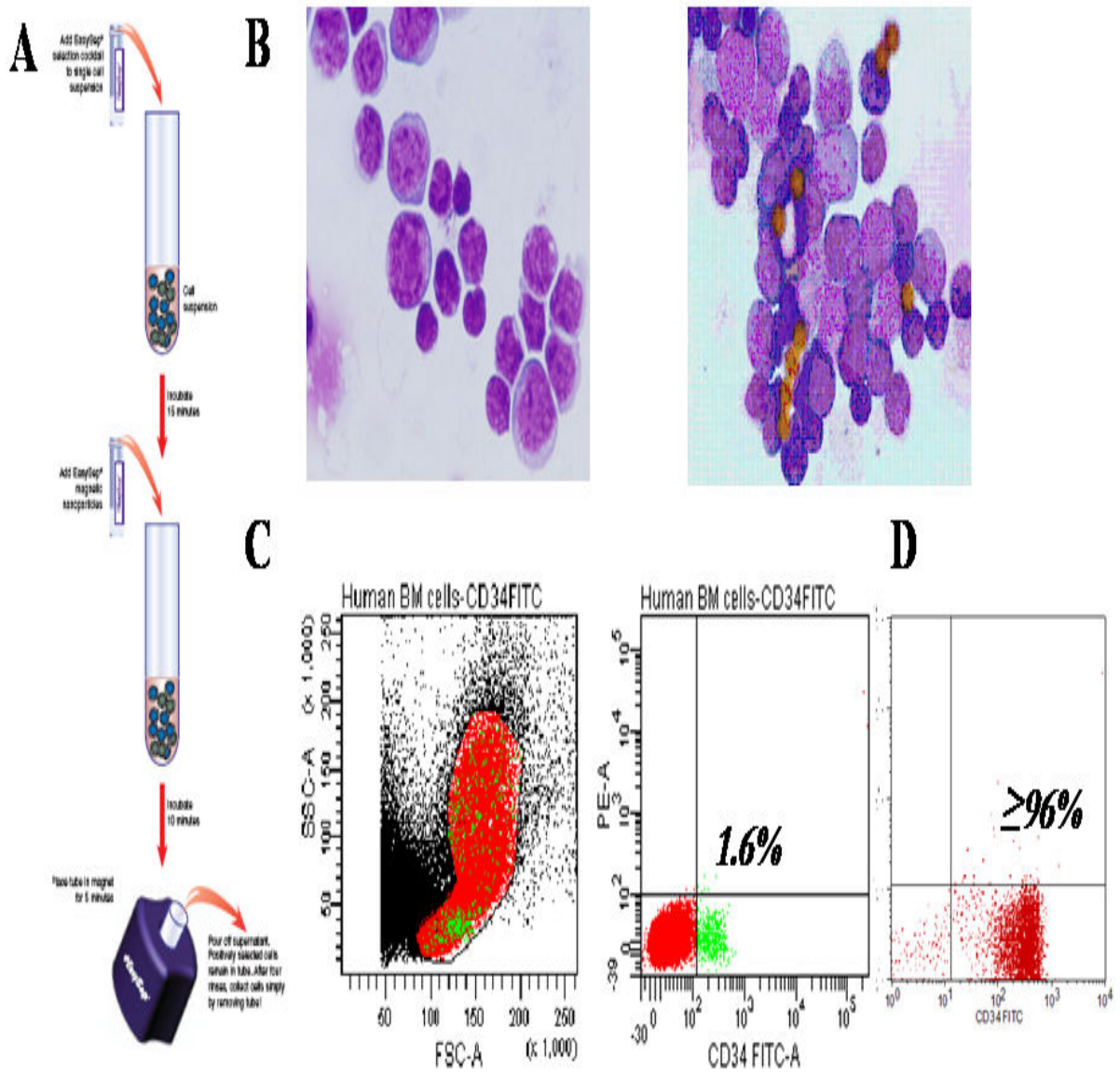

Figure 16- Purification of human hematopoietic progenitor cells (CD34⁺). (A) Schematic representation of magnetic positive selection procedure. Bone marrow CD34⁺ cells (B, Left), Bone marrow CD34 carrying cells and magnetic beads (B, Right). Flow cytometric analysis of magnetic selected cells (C, Left), CD34⁺ subpopulation representing about 2% of total bone marrow (C, Right). Assessment of phenotypic purity of CD34⁺ isolated fraction. Numbers indicate the percentage of the total cells localized in the indicated quadrants.

In the comparative ChIP experiments on human HPCs, harvested from human leukapheresis samples (hereafter referred to as bone marrow cells), binding of the E2A and HEB to HS3, and particularly to HS2 and β -promoter was observed (Figure 17.A and B), and their patterns of association were similar. E2A and HEB were also associated with the γ -promoters. We carried out ChIP analyses for ETO-2 and found that ETO-2 is significantly recruited to the LCR and β -promoter but not to γ -promoters (Figure 17.C). These findings are explained seeing that CD34⁺ cells were purified from leukapheresis samples and the patients received stem cell factor (SCF) and granulocyte colony-stimulating factor (G-CSF) treatment to increase CD34⁺ cell mobilization. The addition of SCF to G-CSF remarkably enhances the mobilisation of peripheral blood progenitor cells.²⁰³ SCF can also induce γ -globin expression in adult human erythroblasts.²⁰⁴ The same finding was observed in terms of EKLF recruitment to γ -promoter in human CD34⁺ cells (Chapter 1, Figure 12). ETO-2 binding pattern is consistent with the low level of β -globin gene expression in primitive progenitor cells and the expected effect of ETO-2 as a repressor of transcription.^{205,206} Using ChIP assays, we similarly demonstrated the presence of HDAC-1 at the LCR and the γ - and β -promoter regions. As shown in Figure 17.D, all regulatory regions appeared to be active binding site for HDAC-1 and the binding was relatively alike across the locus but not at the control region (p21 promoter).

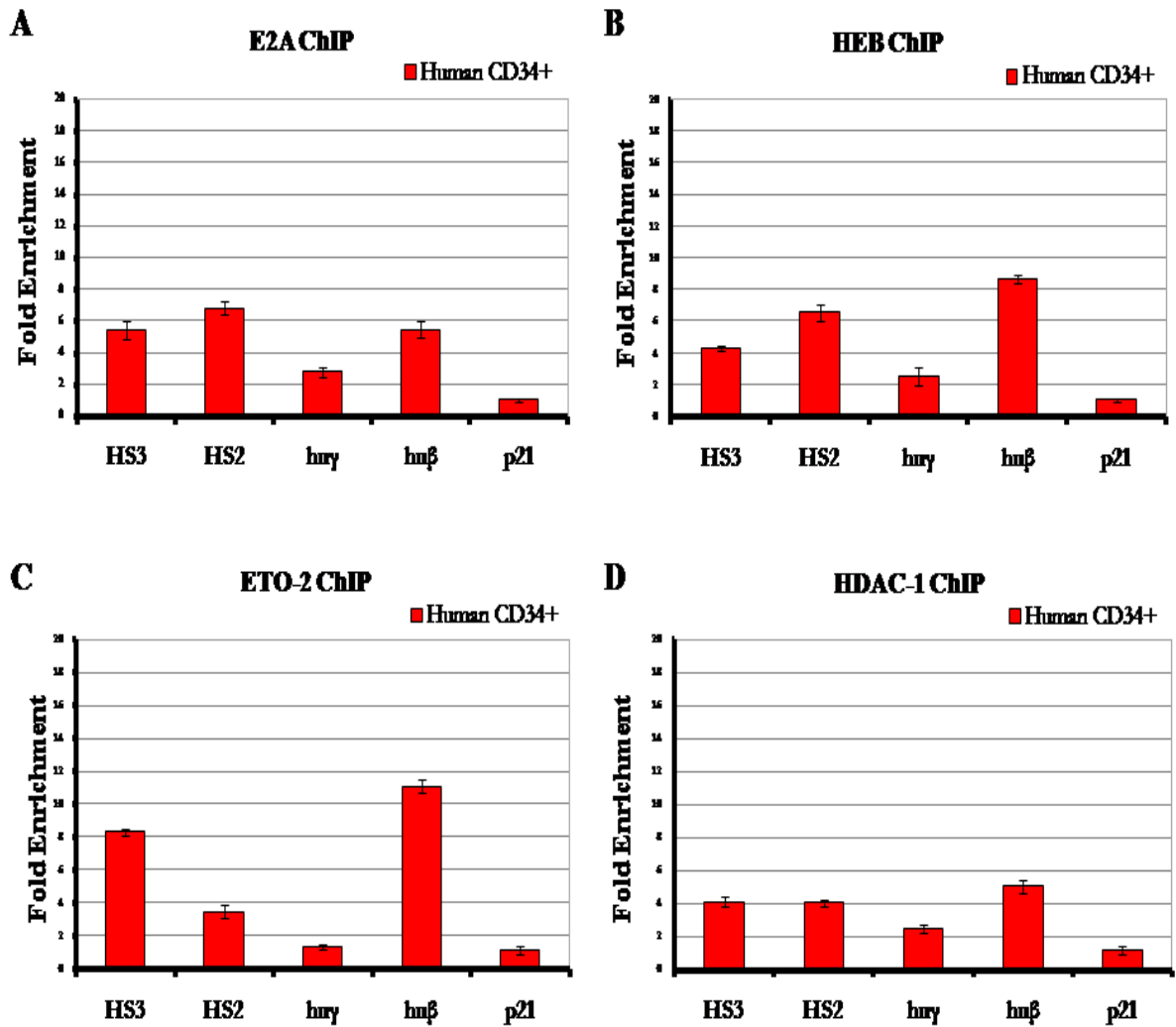

Figure 17- Chromatin immunoprecipitation (ChIP) assays on human CD34⁺ multipotent HPCs cells. Immunoprecipitated with antibodies against (A) E2A, (B) HEB, (C) ETO-2 and (D) HDAC-1 and unbound chromatin samples were subjected to real-time PCR with primer sets specific for the human β -globin locus (HS3, HS2, human γ - and β -promoters) and with another primer set specific for human PAX6 (Paired box gene 6) gene promoter; p21 (Cyclin-dependent kinase inhibitor 1A, also known as CDKN1A) gene promoter is used as a control for ChIP procedure. The level of enrichment (according to the $2^{-\Delta\Delta C_t}$ method)²⁰⁷ of globin regions relative to PAX6 and input is shown by bars, with their corresponding standard deviations. A value of 1 indicates no enrichment. Each value is the mean \pm SD of at least three independent experiments.

Identification of factors bound to the human β -globin locus in murine lymphoid progenitor (LP: Lin⁻c-Kit^{low}Sca1^{low}IL-7R α ⁺) cells

Adult In2 mice were killed and murine LPs were isolated from bone marrow using Lin⁻c-Kit^{low}Sca1^{low}IL-7R α ⁺ expression profile. Lin⁻c-Kit^{low}Sca1^{low} cells were initially isolated by negative selection magnetic system (Figure 18.A) and then stained for IL-7R α and sorted by FACS Vantage Flow Cytometer/Cell Sorter machine. These cells (Lin⁻c-Kit^{low}Sca1^{low}IL-7R α ⁺) include about 0.2% of adult bone marrow cells (Figure 18.B). The purity of sorted population was always $\geq 95\%$ (Figure 18.C).

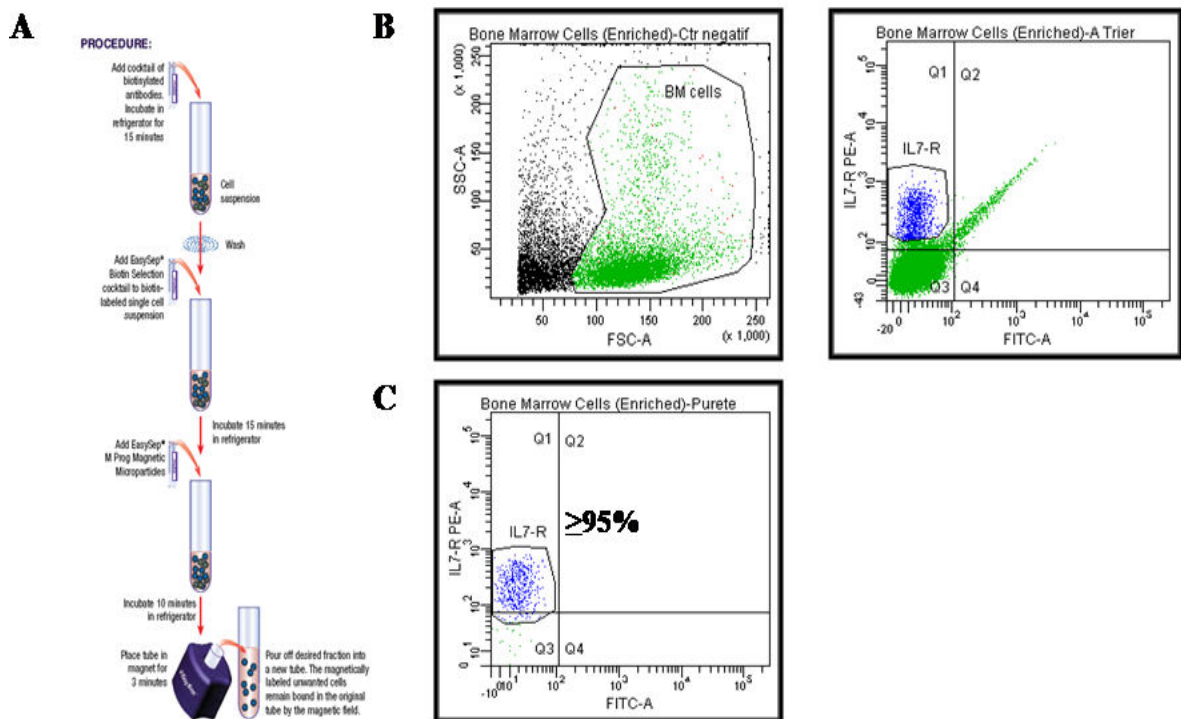

Figure 18- Purification of murine lymphoid progenitor (LP: Lin⁻c-Kit^{low}Sca1^{low}IL-7R α ⁺) cells.

(A) Schematic representation of magnetic negative selection procedure. Lin⁻c-Kit^{low}Sca1^{low} cells (B, Left) were stained with IL-7R α antibody and those positive for IL-7R α were gated and sorted by FACS Vantage Flow Cytometer/Cell Sorter machine. This subpopulation was representing about 2% of total bone marrow (B, Right). (C) Assessment of phenotypic purity of IL-7R α ⁺ isolated fraction. Numbers indicate the percentage of the total cells localized in the indicated quadrants.

The lymphoid developmental potential of enriched LP pop of cells from bone marrow and the sorted LP population were determined in long term bone marrow culture (LTBMC) according to Whitlock-White (W-W) culture system (Figure 19). W-W culture is an established in vitro model system specific for the lymphoid-lineage hemopoiesis.²⁰⁸ The cultured cells were fed by the removal of the growth medium and replenishment with the fresh medium. Colonies were counted 3 weeks after the incubation. The myeloid-specific differentiation potential of murine HPCs was also verified by Whitlock-Witte culture system. The ratio of LP cells/Total Bone Marrow was calculated by limiting dilutions using the LDA program. We observed a linear relationship between the number of cells plated and the number of B-cell colonies obtained, with an average of 1 LP/5000 MNC (Table-3). As expected, LP cells did not show any erythro-myeloid activity evidenced by no growth in complete methylcellulose-based M3434 medium, and HPCs did not yield any cell with lymphoid-lineage potential in W-W culture system vice versa.

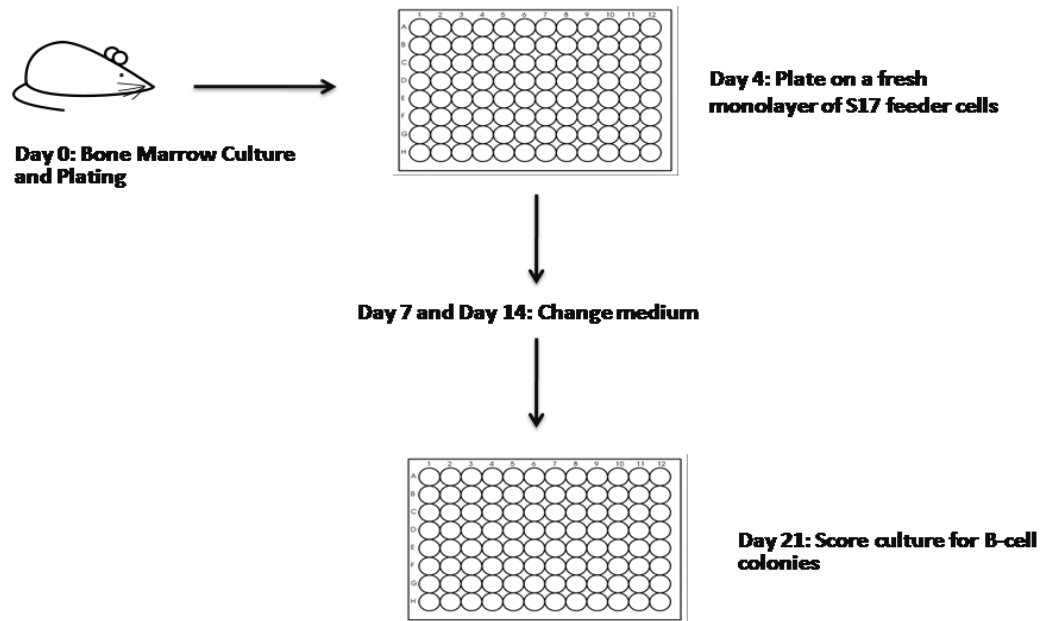

Figure 19- Whitlock-Witte long-term bone marrow culture. Bone marrow cells from adult mice were extracted and plated on a fresh monolayer of S17 stromal cells. B-cell colonies were scored at day 21.

	Colonies/10 ³ cells	Colonies/10 ³ cells
	M3434 culture	Whitlock-Witte assay
HPC: Ly-6C ⁻ CD31 ^{high} c-Kit ⁺	220 ± 25	0
LP: Lin ⁻ c-Kit ^{low} Sca1 ^{low} IL-7R α ⁺	0	ND
	Colonies/10 ⁴ cells	Colonies/10 ⁴ cells
Total Bone Marrow	41 ± 8	3.75 ± 1.2

Table 3- The ratio of LP (lymphoid progenitor) cells/Total Bone Marrow was calculated by limiting dilutions using the LDA program. We observed a linear relationship between the number of cells plated and the number of B-cell colonies obtained, with an average of 1 LP/5000 MNC. As expected, LP cells did not show any erythro-myeloid activity evidenced by no growth in complete methylcellulose-based MethoCult M3434 medium by performing colony-forming cell (CFC) assays. Similarly, HPCs did not yield any cell with lymphoid-lineage potential in Whitlock-Witte culture system.

Histone H3 acetylation (H3Ac) at the lysine-9 and -14 (K9) are well-established markers of active chromatin and presumably leads to the formation of a chromatin environment that promotes the accessibility of promoters to transcription factors and thus the transcription.²⁰⁹ We tested the hypothesis that β -globin locus is in active chromatin in LP cells that is manifested as increased histone acetylation at the K9 and k14 residues of the H3 histone associated with the LCR and γ - and β -promoters. Using CHIP assay, we studied the pattern of histone acetylation at the β -globin locus and showed for the first time that β -globin locus is in active chromatin configuration in LP cells evidenced by enrichment of H3Ac at LCR (HS3 and HS2) and γ - and β -promoters with a trend toward greater acetylation at HS2 and β -promoter (Figure 20.A). To determine if histone acetylation of β -globin locus is associated with increased interaction between transcription

factors and the regulatory regions, we performed ChIP analysis for E2A and HEB. Our data indicated that the chromatin acetylation status correlated with the binding of E2A (Figure 20.B). The HS3, HS2 and β -promoter interacted mainly with E2A though minimal binding of HEB was also seen at LCR (HS3, HS2) (Figure 20.C). γ -promoters was also found to be positive for E2A (Figure 20.B). These results suggest the basal level of β -globin expression in LP cells is mediated by recruitment of E2A and minimal binding of HEB. Since ETO-2 binding mediates the repressive effect, we examined the interaction of ETO-2 with the LCR and γ - and β -promoters using ChIP assay. All the regulatory regions exhibited high level of binding for ETO-2 (Figure 20.D). Thus the presence of ETO-2 could prevent high level of globin gene expression in LP cells. To obtain some more information, mRNA expression of human β -globin gene was determined by RT-PCR of total RNA obtained from LP cells and data was calculated as relative expression to HPCs (HPC/LP: 15X) and to erythroid cells (EryC/LP: 2400X). Taking all together, our findings suggest that human β -globin is in active chromatin in LPs characterized by H3Ac binding according to ChIP assays and basal level of expression according to RT-PCR results.

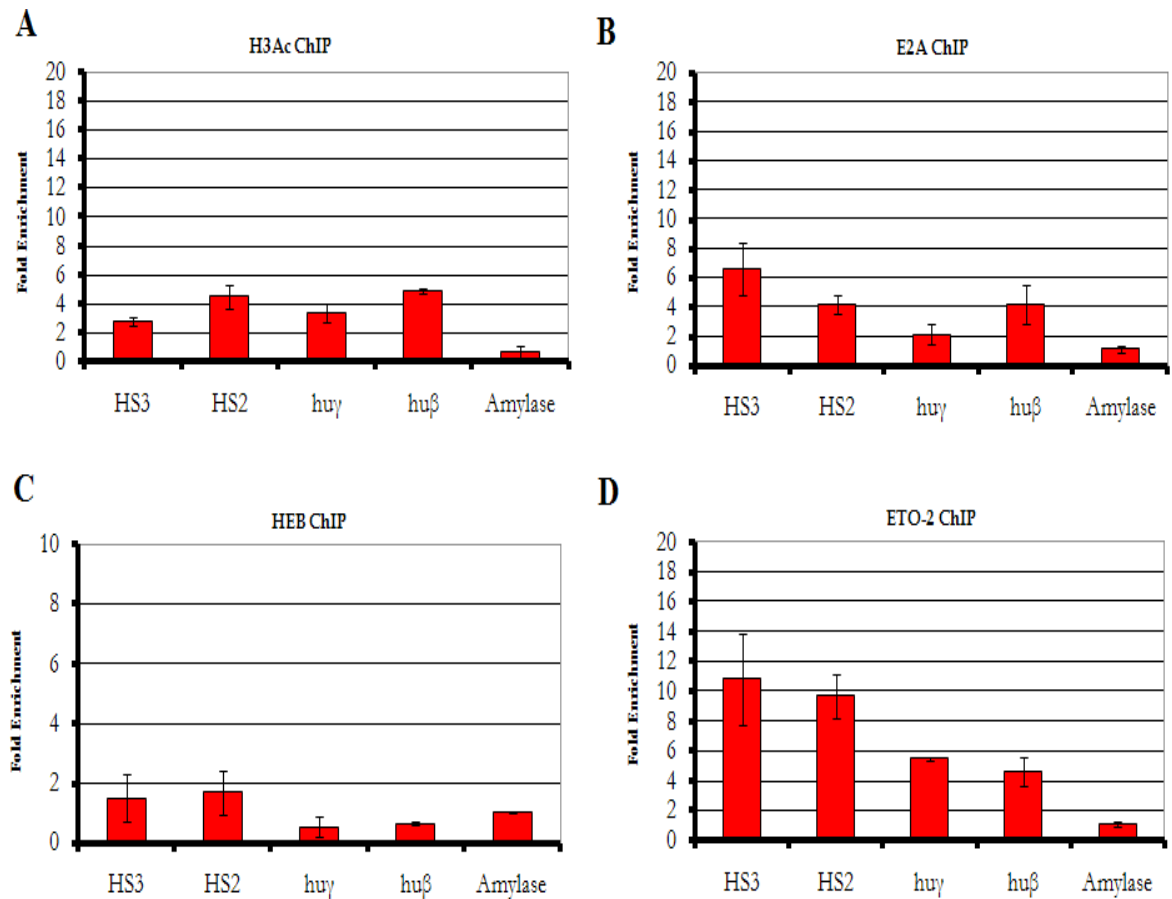

Figure 20- ChIP analysis of histone acetylation and interaction of E2A, HEB and ETO-2 proteins with the human β -globin locus in LP ($\text{Lin}^{-}\text{c-Kit}^{\text{low}}\text{Sca1}^{\text{low}}\text{IL-7R}\alpha^{+}$) cells from adult In2 mice. (A) Acetyl-histone H3 profiling of globin gene locus was assayed using ChIP. Immunoprecipitated chromatin with antibodies against (A) Acetyl-histone H3, (B) E2A, (C) HEB or (D) ETO-2, and unbound chromatin samples were subjected to real-time PCR with primer set specific for the human β -globin locus (HS3, HS2, human γ - and β -promoters) and with another primer set specific for mouse THP (kidney-specific Tamm-Horsfall gene) gene promoter. The silent Amylase promoter was used as a negative control and to set the baseline of one-fold enrichment. The level of enrichment (according to the $2^{\Delta\Delta\text{Ct}}$ method)²¹⁰ of globin regions relative to THP and input is shown by bars, with their corresponding standard deviations. A value of 1 indicates no enrichment. Each value is the mean \pm SD of at least three independent experiments.

Identification of factors bound to the human β -globin locus in fetal erythroid cells with E2A and HEB knock-out background

Novel mouse models knock-out for E2A and HEB and transgenic for human β -globin locus were generated after a long process of breeding of homozygous mutant mice for E2A and HEB (E2A +/- and HEB +/-) with males or females of *ln2* +/+ background, respectively (Figure 21.H). As described above, E2A knockout (E2A-/-) and HEB knockout (HEB -/-) genotypes are almost always lethal before birth;²¹¹ therefore, hematopoietic cells from E2A- and HEB-null backgrounds were harvested from fetal livers of 13.5 dpc embryos. All genotypes were confirmed by polymerase chain reaction. Representative PCR analyses of genomic DNA prepared from fraction of these cells and their corresponding PCR products are shown in Figure 9. All animals were maintained under specific-pathogen-free conditions.

Fetal liver erythroid cells (FL EryC 13.5 dpc) with E2A-/- *ln2*+ or HEB-/- *ln2*+ genotype were subjected to ChIP assays, in separate experiments, to investigate the effect of absence of either E2A or HEB on recruitment of other factors to β -globin locus. The alteration of transcriptional network at globin locus in erythroid cells and the possibility of compensatory factors, when E2A and HEB proteins are absent, can be investigated by such knock-out studies. ChIP samples from knock-out and wild-type backgrounds were prepared in simultaneous parallel experiments for each protein. As expected, both E2A and HEB were first detected at the regulatory regions, LCR and β -promoter, of β -globin locus in wild-type background (Figure 21.A and D). The pattern of recruitment was similar to and so confirmatory the data found in terms of erythroid cells (Ter119⁺) in normal *ln2* background. Neither E2A nor HEB was bound to γ -promoters in wild-type fetal liver erythroid cells (Figure 21.A and D). Similar enrichments were observed as high level of ETO-2 binding at both the LCR and β -promoter and also as minimal binding thereof at γ -promoters (Figure 21.B and E). Generally, in both knock-outs, a slight increase in binding potential was observed for all factors when the ChIP results of knock-out backgrounds were

compared to those obtained from wild-type. That is, when ChIPs performed with HEB antibody on E2A-knock-out FL EryCs and also when ChIPs performed with E2A antibody on HEB-knock-out FL EryCs, the higher level of enrichment was detected (Figure 21.A and D). In addition, γ -promoters were found to be positive for both E2A and HEB in knock-out backgrounds (Figure 21.A and D). Further to such findings, one may argue that the recruitment of any of these two factors was either entirely independent of the presence of another indicating that their recruitment was not a reflection of the expression levels of the other and thus suggesting the existence of different protein complex at β -globin locus, or they can have repressor activity independently. This increase in enrichment was more obvious in case of ChIP assays with anti-ETO-2 in both E2A and HEB knockouts (Figure 21.A and D). When it came to ChIP assays for HDAC-1 protein, a lower level of HDAC-1 enrichment was evenly detected at the LCR and β -promoter in wild-type and knock-outs of both E2A and HEB (Figure 21.C and F). Moreover, the γ -promoters were identified as negative for HDAC-1 recruitment in both E2A and HEB knock-outs (Figure 21.C and F).

The E2A and HEB recruitment could not be detected by immunoprecipitation with related antibodies in corresponding knock-out background (Figure 21G), confirming the specificity of the antibodies used in the ChIP assays and genotypes of extracted fetal liver cells and the accuracy of ChIP experiments.

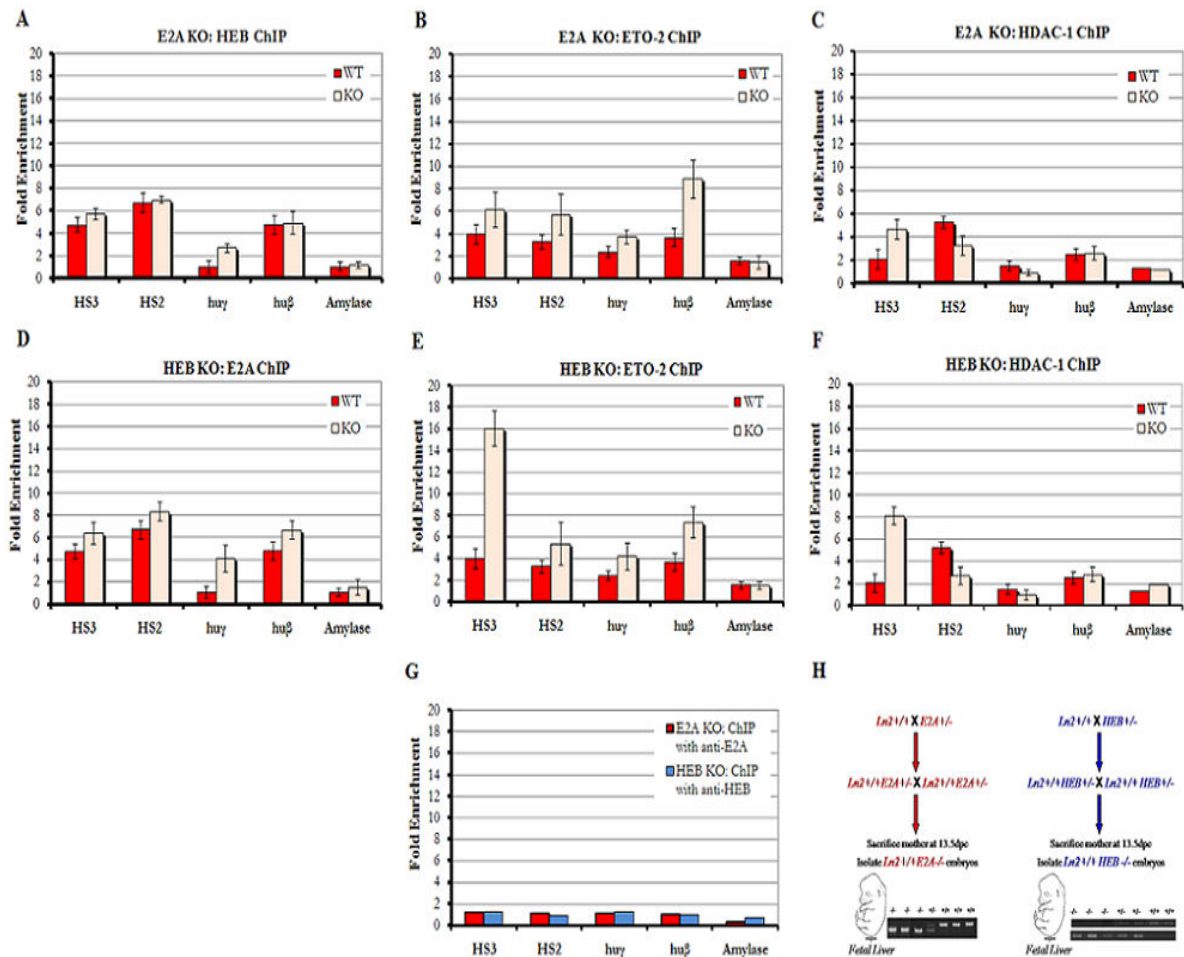

Figure 21- ChIP assays on fetal liver erythroid cells (13.5 dpc) with wild-type and knock-out backgrounds. Immunoprecipitated chromatin with antibodies against (A) HEB, (B, E) ETO-2, (C, F) HDAC-1 or (D) E2A, and unbound chromatin samples either in E2A knock-out erythroid cells (A, B and C) or in HEB knock-out erythroid cells (D, E, F) were subjected to real-time PCR with primer sets specific for the human β -globin locus (HS3, HS2, human γ - and β -promoters) and with another primer set specific for mouse THP (kidney-specific Tamm-Horsfall gene) gene promoter. The similar assays were performed using antibodies against the knock-out proteins to control the ChIP experiments (G). The silent Amylase promoter was used as a negative control and to set the baseline of one-fold enrichment. The level of enrichment (according to the $2\Delta\Delta C_t$ method)²¹² of globin regions relative to THP and input is shown by bars, with their corresponding standard deviations. A value of 1 indicates no enrichment. Each value is the mean \pm SD of at least three independent experiments. (H) Schematic diagram of generation and establishment of knock-out mouse models used in study and representative PCR analysis of genotype (see methods and Figure 9).

Discussion

The combination of chromatin immunoprecipitation (ChIP) assay with real-time PCR has provided a major boost to quantitatively measure the relative interaction of transcription factors with endogenous chromatin sites in living cells.²¹³ ChIP analyzing helps to understand how transcription factors select functional sites in the genome.²¹⁴ This attests to the intense interest in the field globin research and the acknowledgement of the potential for animal modeling to advance understanding in this area. We utilized the power of mouse genetics to propose incisive information about the transcriptional control of β -globin locus during hematopoiesis. Animal model of human β -globin locus, namely Ln2, is a widely accepted and well established model to investigate the molecular events regulating the β -globin locus during erythropoiesis.^{215,216}

Understanding the *in vivo* function of the LCR and promoters will enrich our knowledge about the process of gene activation. While research on globin has shown a surge in popularity, no group has yet approached the crucial issue of the mechanisms by which E proteins regulate β -globin gene expression *in vivo*. In this respect, our results provide the first evidence to date to support the hypothesis that the E proteins E2A and HEB, are important transcription factors directly involved in regulating the human β -globin locus during hematopoietic differentiation. The present project is in a unique position to address these mechanisms, since we bring together data from different murine hematopoietic cell types containing normal human β -globin locus in combination with the study of knockout backgrounds. This mix is essential to fairly increase the body of knowledge in terms of transcriptional control of β -globin locus by E proteins. Data provided here could be employed in novel pharmacological approaches targeting the mechanisms involved in transcriptional control of β -globin gene expression and hopefully one would come up with new ideas for treatment of sickle cell anemia and/or β -thalassemia.

Human β -globin locus in erythroid cells and murine HPCs

ChIP experiments performed on chromatin prepared from murine erythroid cells and HPCs, harvested from transgenic mouse In2, showed the strong binding of the E2A and HEB to HS3, and particularly to HS2 and β -promoter in both murine HPCs and EryC cells. The patterns of binding were roughly not affected by differentiation from HPCs to EryC cells suggesting that the recruitment of E2A and HEB per se is not modulating the transcription level of β -like globin genes during erythropoiesis. However, the pattern of recruitment suggest that E2A recruitment is more pronounced in HPCs while recruitment of HEB is increasing from HPC to EryC. This model is consistent with the pattern of recruitment and with the role that E2A and HEB play in lymphoid-lineage during B-cell and T-cell differentiation. That is, E2A is recruited to regulatory regions of lymphoid cell-specific genes during lymphoid-lineage priming in the multipotent progenitor population²¹⁷ and HEB is involved in T-lymphoid and B-lymphoid lineage commitment and the expression of lymphoid-lineage specific genes in more mature cells.^{218,219,220}

Our results suggest that in non-committed hematopoietic progenitor cells the LCR and β -globin promoter are already occupied by E2A and HEB. We also show that the binding of E2A and HEB to crucial regulatory regions on β -globin locus, at specific stages of differentiation, is associated with ETO-2 and HDAC-1 factors. A noticeable binding of ETO-2 to β -promoter in HPCs could explain the basal-level of β -globin gene expression once the activating effects of E2A and HEB are counterbalanced by ETO-2 and thus suggests that the previously published complex²²¹ which contains E2A, HEB and ETO-2 present at β -promoter in HPCs. The reduction in ETO-2 binding to β -promoter in erythroid cells, even if E2A and HEB are highly recruited to both, the LCR and β -promoter, is consequential with the high-level of β -globin gene expression to erythroid cells. HDAC-1 was also evenly recruited to HS3, HS2 and β -promoter in both HPCs and EryC suggesting that the repression activity of ETO-2 in HPCs is in part due to the recruitment of the transcription repressor HDAC-1. The fact that E2A and HEB binding could not be detected

(at significant level) by ChIP assays at γ -globin promoters, further supports the activating role of E2A and HEB in globin gene expression since the γ -globin genes are not transcriptionally active in EryC at that stage of development. The potentiation of globin genes in hematopoietic progenitor cells is actually gene specific during development and fits with the subsequent transcriptional activation of the specific globin genes.^{222 223}

This differentiation-coupled recruitment of E2A, HEB and ETO-2 indicates the harmony between their recruitment to β -globin locus and lineage- differentiation along with commitment. Results from our study suggest that E2A and HEB form homo- and heterodimers that bind to erythroid cell-specific genes.

Human β -globin locus in human primitive progenitor cells

Human early hematopoietic forming progenitor cells (human CD34⁺ cells) represent 1-3% of total human bone marrow cells. Colony-forming assays have shown that this population includes all unipotent, colony units-granulocyte-macrophage (CFU-GM), CFU megakaryocyte (CFU-meg), burst forming units-erythroid (BFU-E) and multipotent progenitors CFU granulocyte/erythroid/macrophage/megakaryocyte (CFU-GEMM) as well as pre-CFU.²²⁴ ChIP analysis performed on human HPCs harvested from human leukapheresis samples showed that E2A and HEB bind to HS3, and particularly to HS2 and β -promoter, and seem to follow a similar pattern of recruitment. These results further suggest the importance of E2A and HEB in the human β -globin gene potentiation and in the basal level of gene expression in HPCs.

Interestingly, we also found that E2A, HEB and also EKLF were associated with the γ -promoter. These findings were expected in the light of treatment of leukapheresis samples with stem cell factor (SCF) and granulocyte colony-stimulating factor (G-CSF) to increase CD34⁺ cell mobilization.²²⁵ SCF can induce γ -globin expression in adult human erythroblasts.²²⁶ Similarly, previous studies have reported that the reactivation of fetal hemoglobin (HbF, $\alpha_2\gamma_2$) synthesis and erythroid cell proliferation can be achieved by

addition of biosynthetic GM-CSF.²²⁷ The mechanisms underlying HbF reactivation have not been elucidated yet, but the modification of chromatin structure of the β -like globin gene cluster is raised as a possible mechanism of action.²²⁸ HDAC-1 is present at all regulatory regions across the locus. HDACs can induce local condensation in chromatin through the deacetylation of the acetylated lysine residues in histone tail and block access of transcriptional factors.²²⁹ The histone deacetylase (HDAC) inhibitors like sodium butyrate (NaB) and trichostatin A (TSA) were shown to be able to maintain active chromatin structure at γ -globin promoter, via histone hyperacetylation, and thus maintain the expression of the fetal globin gene and HbF production.^{230,231,232} The γ -globin promoters may be up-regulated by binding of transcription factors evidenced herein by recruitment of EKLf, E2A and HEB and the absence of ETO-2 as a repressor of transcription. ETO-2 binding pattern to LCR and β -promoter but not to γ -promoters was again consistent with the low level of β -globin gene expression in early progenitor cells and the expected effect of GM-CSF in stimulating the promoters of γ -globin genes. These data recommend the pharmacologic agents able to alter the chromatin structure as attractive drugs to reach the clinically effective levels of HbF production and open new horizons to treatment of individuals with sickle cell anemia and β -thalassemia in the future.

Human β -globin locus in murine lymphoid progenitor cells (LPs)

We next focused on the β -globin locus in lymphoid progenitor cells (LPs) to investigate the epigenetic state of the promoter and an upstream control region (LCR). Murine LPs were isolated from adult bone marrow according to their specific cell surface markers (Lin⁻c-Kit^{low}Sca1^{low}IL-7R α ⁺).

Histone H3 acetylation (H3Ac) at the lysine-9 (K9) is an epigenetic mark usually associated with active chromatin and is a characteristic of transcriptional activation in active genes.²³³ Acetylation of the histone tails disrupts histone binding to negatively charged DNA and thus forms an open active chromatin (euchromatin) that promotes the transcription factor binding, i.e. genes in open chromatin domains are prepared for

expression. Once the activator proteins bind to regulatory regions, transcription commences and high-level of gene expression is achieved. Firstly, histone modifications were analyzed by ChIP assays and general acetylation of H3 was observed at both the promoters of γ - and β -genes and LCR. By such findings, we showed for the first time that β -globin locus is in open chromatin configuration in lymphoid progenitor cells which is consistent with the basal level of expression of globin genes in lymphoid progenitors.

There has been no previous study to directly characterize E2A and HEB binding to β -globin locus in lymphoid progenitor cells (LPs). In fact, the investigation of the chromatin organization and transcription factor recruitment at the beta-globin locus in LP has never been done before. The attempts were made to assess whether histone acetylation of β -globin locus is associated with increased interaction between transcription factors and the regulatory regions. There is a marked binding of E2A to regulatory regions, at both the LCR and promoters, across the locus. Moreover, HEB protein was found to be minimally present at LCR and β -promoter at a basal level. There was significant enrichment of ETO-2 at both, the LCR and promoters that marks characteristic of repressed gene promoters. Thus, the β -globin gene locus may exist in an open chromatin conformation in LPs before terminal lymphoid differentiation, and the assemblage of functional transcription apparatus to the LCR and active promoters may be a lineage-specifying and rate-limiting step in activation of β -globin gene expression. The histone acetylation that we observed here is not exceptional. Previous studies have similarly shown that several active genes like interferon- α (IFN- α)²³⁴ and hormone receptor-dependent genes²³⁵ in mammals, and PHO8 gene in *Saccharomyces cerevisiae*,²³⁶ are hypoacetylated to facilitate the recruitment of remodeling complexes. We conclude that histone the histone post-translational modifications and E2A binding to LCR and β -promoter in LPs results in a basal level of β -globin expression.

To verify the transcriptional effects of these factors on β -globin gene expression following their binding to locus, we also studied the level of β -globin gene expression in LPs. The concentration of human β -globin gene mRNA was determined by RT-PCR of

total RNA obtained from LP cells and data was calculated as relative expression to HPCs (HPC/LP: 15X) and to erythroid cells (EryC/LP: 2400X). These results show that the H3 acetylation and binding of E2A alone at the LCR and β -promoter is not sufficient for high level of transcription. This reduction of β -globin gene expression could be mediated in part by recruitment of ETO-2 to crucial regulatory regions. Other epigenetic mechanisms and repressive factors may also influence transcriptional activity and contribute to such decrease in expression.

Our results suggest that the β -globin gene and promoter would first be epigenetically marked by histone H3 acetylation in LPs and by basal level of expression prior to differentiation to more mature lymphoid cells where the locus is epigenetically silenced by the formation of a heterochromatin structure.

E2A and HEB are associated with lineage- differentiation and commitment

Taken together, results of the present study suggest that a defined pattern of transcription factor binding is important for the specific activation of human globin promoters and the human globin LCR in HPCs and erythroid cells. We showed that E2A and HEB drive β -promoter and β -LCR activity in HPCs through their high-affinity binding to two important regulatory regions: LCR and β -promoter.

Earlier *in vivo* studies have indicated that chromatin is in open configuration at the human β -globin promoters and β -LCR in HPCs. The chromatin accessibility and recruitment of activating transcription factors to human β -globin regulatory regions set the gene-specific potentiation in HPCs before erythroid-lineage commitment. Accessibility at HS2 and HS3 increases in mature erythroid cells comparing with HPCs.²³⁷ Herein, ChIP results from murine HPCs and human CD34⁺ cells suggest that β -globin gene-potentiation in HPCs are mediated in part by binding of E2A and HEB, particularly of E2A to β -LCR and β -promoter. During erythroid differentiation from HPCs to erythroid cells, ETO-2 binding affinity decreases at the LCR and promoters as cells progress through the later

stages of erythroid differentiation. Thus, high-level of β -globin gene expression in erythroid cells versus basal-level of β -globin gene expression in HPCs are acquired, after further remodeling of LCR and β -promoter during differentiation, through binding of different factors and/or with different relative ratios to the same regulatory regions. The ETO-2 counterbalances the activating effect of E2A and HEB in HPCs but not in erythroid cells. However, E2A and HEB alone are not sufficient and other factors are definitely required for an appropriate gene expression in different stages of differentiation.

Significantly, our results suggest that the pattern of histone acetylation in LPs is important for the transcriptional potentiation of globin genes and, more interestingly, for the developmentally regulated expression of these genes in erythroid cells. We show that the promoters of human globin genes are epigenetically active such as evidenced by histone H3 acetylation in LPs and we suggest that this potentiation allows proper expression in terminally differentiated erythroid cells via the recruitment of activators and/or remodeling complexes.

Human β -globin locus in E2A and HEB knock-out fetal erythroid cells

Novel mouse models knock-out for E2A and HEB and transgenic for human β -globin locus were generated in present project. Since E2A knockout (E2A^{-/-}) and HEB knockout (HEB^{-/-}) genotypes were almost always lethal,²³⁸ fetal EryC from E2A- and HEB-null backgrounds were harvested from fetal livers of 13.5 dpc embryos. About 80-90% of cell population harvested from 13.5 dpc fetal liver consists of erythroid cells. No deviation in phenotype was detected in mice heterozygote for E2A (+/-) or HEB (+/-) or in 13.5 dpc embryos. The knock-out study was a major advantage of this project as the alteration of transcriptional network at globin locus in erythroid cells and the possibility of compensatory factors could be investigated when E2A and HEB proteins were absent.

ChIP assays were performed on fetal liver erythroid cells with wild-type and knock-out (E2A^{-/-} In2⁺ or HEB^{-/-} In2⁺) backgrounds in simultaneous parallel experiments. Both

E2A and HEB were detected at the regulatory regions, LCR and β -promoter, on β -globin locus in wild-type, which further emphasized their presence as a part of transcriptional network involved in β -globin gene expression. These data are consistent with our findings in erythroid cells (Ter119⁺) in normal In2 background. With similar explanation, neither E2A nor HEB was bound to γ -promoter in wild-type fetal liver erythroid cells while high level of enrichment was seen for ETO-2 at both LCR and β -promoter besides its minimal binding to γ -promoter.

In both E2A and HEB knockouts, a slight increase in binding potential was observed for all factors when the ChIP results of knock-out backgrounds were compared to those obtained in wild-type. In addition, γ -promoters was found to be positive for both E2A and HEB in knock-out backgrounds. The absence of E2A in the knockout mice could be compensated by recruitment of HEB, and vice versa. The in vivo association of E2A and HEB to LCR and β -promoter indicates that a knockout of E2A or HEB gene does not inhibit the recruitment of the other. In other words, the recruitment of any of these two factors is independent of the presence of the other indicating that their recruitment is not a reflection of the expression levels of the other.

These observations suggest that neither E2A nor HEB are the limiting factor for the formation and recruitment of the ETO2 containing complex sitting at the locus. E2A and HEB are most likely in that complex but only one of them is sufficient for the recruitment of this ETO-2 complex to the locus. Given the dynamic nature of these protein complexes and widespread nature of E protein expression, their expression levels and their relative ratio could fluctuate during hematopoiesis and consequently master the lineage-specific gene expression. One may argue that E2A and HEB proteins can be present in different, and at least in more than one, protein complexes at locus and therefore be targeted to regulatory sequences through participation in different protein complexes. Supporting this issue, E2A and HEB are recently demonstrated to bind to β -globin LCR and β -globin gene promoter during erythroid differentiation via two different protein complexes of ETO-2 and

TAL-1, and TAL-1, HEB and E2A protein levels have been shown to fluctuate during differentiation. The detachment of ETO-2 complex, evidenced by decrease in level of ETO-2, allows the activation of late erythroid genes. Therefore, the function of E2A and HEB in transcription activation has been postulated through the cooperation of multiple transactivators.²³⁹

Conclusion

In closing, we wish to emphasize that the ability of E proteins to form different homo/heterodimers make them challenging to study, but our results suggest that E-protein are key players in the expression of β -globin gene during erythroid differentiation from HPCs to mature erythroid cells. The accumulation of E proteins increases at β -globin locus in parallel with lineage-specification and commitment. As discussed here, initially in triggering hematopoiesis and later at each step of differentiation, the accumulation of a large amount of small changes in chromatin structure and transcription factors will form a finely orchestrated network necessary for developmental changes. The expression of a variety of tissue-specific genes is potentiated in progenitor cells and the chromatin preserves an accessible configuration for transcriptional machinery. Gene potentiation appears to counterbalance epigenetic silencing of lineage-specific genes in early progenitors, while maintaining an accessible chromatin conformation in the lineage pathway selected. Our results emphasize the complementary role of locus control region (LCR) or LCR-like structures and promoter regions in gene-specific potentiation events. The interplay between ubiquitous transcription factors, lineage-specific transcription factors, and chromatin remodeling activities determines the outcome of transcription. In addition, different sets of E protein target genes could be activated at each step. A comprehensive understanding of how E proteins could regulate globin gene expression calls for more studies from a molecular standpoint.

References

- 1 Anthony S. Fauci, Eugene Braunwald, Dennis L. Kasper, Stephen L. Hauser, Dan L. Longo, J. Larry Jameson, and Joseph Loscalzo, Eds. *Harrison's Principles of Internal Medicine*. 17th ed. McGraw-Hill, 2008.
- 2 Zon LI. Developmental biology of hematopoiesis. *Blood*. 1995 Oct 15;86(8):2876-91.
- 3 http://www.medscape.com/content/2004/00/47/20/472097/472097_fig.html
- 4 Cheung AM, Kwong YL, Liang R, Leung AY. Stem cell model of hematopoiesis. *Curr Stem Cell Res Ther*. 2006 Sep;1(3):305-15.
- 5 <http://www.brown.edu/Courses/BI0032/adltstem/bone-marrow.gif>
- 6 Haylock DN, Nilsson SK. Stem cell regulation by the hematopoietic stem cell niche. *Cell Cycle*. 2005 Oct;4(10):1353-5.
- 7 Cheung AM, Kwong YL, Liang R, Leung AY. Stem cell model of hematopoiesis. *Curr Stem Cell Res Ther*. 2006 Sep;1(3):305-15.
- 8 Orkin SH. Transcription factors and hematopoietic development. *J Biol Chem*. 1995 Mar 10;270(10):4955-8.
- 9 Nienhuis AW, Barker JE, Croissant RD. Overview: mechanisms of the regulation of hemoglobin synthesis at the cellular level. *Ann N Y Acad Sci*. 1980;344:189-205.
- 10 Anthony S. Fauci, Eugene Braunwald, Dennis L. Kasper, Stephen L. Hauser, Dan L. Longo, J. Larry Jameson, and Joseph Loscalzo, Eds. *Harrison's Principles of Internal Medicine*. 17th ed. McGraw-Hill, 2008.
- 11 Lane P, Gross S. Hemoglobin as a chariot for NO bioactivity. *Nat Med*. 2002 Jul;8(7):657-8.
- 12 Perutz MF. Hemoglobin structure and respiratory transport. *Sci Am*. 1978 Dec;239(6):92-125.
- 13 Murayama M. The chemical and the three-dimensional structure of human hemoglobin. *Ann Clin Lab Sci*. 1971 Jul-Aug;1(1):1-9.
- 14 <http://porpax.bio.miami.edu/~cmallery/150/gene/c7.19.17b.families.globin.jpg>
- 15 Anthony S. Fauci, Eugene Braunwald, Dennis L. Kasper, Stephen L. Hauser, Dan L. Longo, J. Larry Jameson, and Joseph Loscalzo, Eds. *Harrison's Principles of Internal Medicine*. 17th ed. McGraw-Hill, 2008.
- 16 <http://www.mie.utoronto.ca/labs/lcdlab/biopic/fig/14.10.jpg>
- 17 Stamatoyannopoulos G. *The molecular basis of blood diseases*. 3rd ed. Philadelphia: W.B. Saunders, 2001.
- 18 Rund D, Rachmilewitz E. Beta-thalassemia. *N Engl J Med*. 2005 Sep 15;353(11):1135-46.
- 19 Cappellini MD. Long-term efficacy and safety of deferasirox. *Blood Rev*. 2008 Dec;22 Suppl 2:S35-41.
- 20 Bhatia M, Walters MC. Hematopoietic cell transplantation for thalassemia and sickle cell disease: past, present and future. *Bone Marrow Transplant*. 2008 Jan;41(2):109-17.
- 21 Inati A, Koussa S, Taher A, Perrine S. Sickle cell disease: new insights into pathophysiology and treatment. *Pediatr Ann*. 2008 May;37(5):311-21.

-
- 22 Fritsch EF, Lawn RM, Maniatis T. Molecular cloning and characterization of the human beta-like globin gene cluster. *Cell*. 1980 Apr;19(4):959-72.
- 23 Tuan D, Solomon W, Li Q, London IM. The "beta-like-globin" gene domain in human erythroid cells. *Proc Natl Acad Sci U S A*. 1985 Oct;82(19):6384-8.
- 24 Stamatoyannopoulos G. Control of globin gene expression during development and erythroid differentiation. *Exp Hematol*. 2005 Mar;33(3):259-71.
- 25 Levings PP, Bungert J. The human beta-globin locus control region. *Eur J Biochem*. 2002 Mar;269(6):1589-99.
- 26 Harju S, McQueen KJ, Peterson KR. Chromatin structure and control of beta-like globin gene switching. *Exp Biol Med*. 2002 Oct;227(9):683-700.
- 27 Li Q, Zhang M, Duan Z, Stamatoyannopoulos G. Structural analysis and mapping of DNase I hypersensitivity of HS5 of the beta-globin locus control region. *Genomics*. 1999;61:183-193.
- 28 Li Q, Peterson KR, Fang X, Stamatoyannopoulos G. Locus control regions. *Blood*. 2002 Nov 1;100(9):3077-86.
- 29 Harju S, McQueen KJ, Peterson KR. Chromatin structure and control of beta-like globin gene switching. *Exp Biol Med*. 2002 Oct;227(9):683-700.
- 30 Grosveld F, van Assendelft GB, Greaves DR, Kollias G. Position-independent, high-level expression of the human beta-globin gene in transgenic mice. *Cell*. 1987;51:975-985.
- 31 Newton DA, Rao KM, Dluhy RA, Baatz JE. Hemoglobin is expressed by alveolar epithelial cells. *J Biol Chem*. 2006 Mar 3;281(9):5668-76.
- 32 Möhle R, Kanz L. Hematopoietic growth factors for hematopoietic stem cell mobilization and expansion.
- 33 Gabilove J. Overview: erythropoiesis, anemia, and the impact of erythropoietin. *Semin Hematol*. 2000 Oct;37(4 Suppl 6):1-3. *Semin Hematol*. 2007 Jul;44(3):193-202.
- 34 Sirén AL, Fratelli M, Brines M, Goemans C, Casagrande S, Lewczuk P, Keenan S, Gleiter C, Pasquali C, Capobianco A, Mennini T, Heumann R, Cerami A, Ehrenreich H, Ghezzi P. Erythropoietin prevents neuronal apoptosis after cerebral ischemia and metabolic stress. *Proc Natl Acad Sci U S A*. 2001 Mar 27;98(7):4044-9.
- 35 Orkin SH. Diversification of haematopoietic stem cells to specific lineages. *Nat Rev Genet* 2000; 1:57-64.
- 36 Sieweke MH, Graf T. A transcription factor party during blood cell differentiation. *Curr Opin Genet Dev* 1998; 8:545-51.
- 37 Etienne J, Brault D, Firmin S. "Cis" and "trans" regulator elements of transcription. *Ann Biol Clin*. 1990;48(10):681-94.
- 38 Grosveld F, van Assendelft GB, Greaves DR, Kollias G. Position-independent, high-level expression of the human beta-globin gene in transgenic mice. *Cell*. 1987 Dec 24;51(6):975-85.

-
- 39 Johnson RM, Prychitko T, Gumucio D, Wildman DE, Uddin M, Goodman M. Phylogenetic comparisons suggest that distance from the locus control region guides developmental expression of primate beta-type globin genes. *Proc Natl Acad Sci U S A*. 2006 Feb 28;103(9):3186-91.
- 40 Li Q, Peterson KR, Fang X, Stamatoyannopoulos G. Locus control regions. *Blood*. 2002 Nov 1;100(9):3077-86.
- 41 Harju S, McQueen KJ, Peterson KR. Chromatin structure and control of beta-like globin gene switching. *Exp Biol Med (Maywood)*. 2002 Oct;227(9):683-700.
- 42 Kornberg RD, Lorch Y. Chromatin structure and transcription. *Annu Rev Cell Biol*. 1992;8:563-87.
- 43 Li Q, Peterson KR, Fang X, Stamatoyannopoulos G. Locus control regions. *Blood*. 2002 Nov 1;100(9):3077-86.
- 44 Harju S, McQueen KJ, Peterson KR. Chromatin structure and control of beta-like globin gene switching. *Exp Biol Med (Maywood)*. 2002 Oct;227(9):683-700.
- 45 Fu XH, Liu DP, Liang CC. Chromatin structure and transcriptional regulation of the beta-globin locus. *Exp Cell Res*. 2002 Aug 1;278(1):1-11.
- 46 Enver T, Raich N, Ebens AJ, Papayannopoulou T, Costantini F, Stamatoyannopoulos G. Developmental regulation of human fetal-to-adult globin gene switching in transgenic mice. *Nature*. 1990 Mar 22;344(6264):309-13.
- 47 Bottardi S, Bourgoïn V, Pierre-Charles N, Milot E. Onset and inheritance of abnormal epigenetic regulation in hematopoietic cells. *Hum Mol Genet* 2005; 14:493-502.
- 48 Li Q, Barkess G, Qian H. Chromatin looping and the probability of transcription. *Trends Genet*. 2006 Apr;22(4):197-202.
- 49 Palstra RJ, de Laat W, Grosveld F. Beta-globin regulation and long-range interactions. *Adv Genet*. 2008;61:107-42.
- 50 Forrester WC, Takegawa S, Papayannopoulou T, Stamatoyannopoulos G, Groudine M. Evidence for a locus activation region: the formation of developmentally stable hypersensitive sites in globin-expressing hybrids. *Nucleic Acids Res*. 1987 Dec 23;15(24):10159-77.
- 51 Li Q, Peterson KR, Fang X, Stamatoyannopoulos G. Locus control regions. *Blood*. 2002 Nov 1;100(9):3077-86.
- 52 Bottardi S, Bourgoïn V, Pierre-Charles N, Milot E. Onset and inheritance of abnormal epigenetic regulation in hematopoietic cells. *Hum Mol Genet* 2005; 14:493-502.
- 53 Bungert J, Tanimoto K, Patel S, Liu Q, Fear M, Engel JD. Hypersensitive site 2 specifies a unique function within the human beta-globin locus control region to stimulate globin gene transcription. *Mol Cell Biol*. 1999 Apr;19(4):3062-72.

-
- 54 Tanimoto K, Liu Q, Bungert J, Engel JD. Effects of altered gene order or orientation of the locus control region on human beta-globin gene expression in mice. *Nature*. 1999 Mar 25;398(6725):344-8.
- 55 Swiers G, Patient R, Loose M. Genetic regulatory networks programming hematopoietic stem cells and erythroid lineage specification. *Dev Biol*. 2006 Jun 15;294(2):525-40.
- 56 Mahajan MC, Weissman SM. Multi-protein complexes at the beta-globin locus. *Brief Funct Genomic Proteomic*. 2006 Mar;5(1):62-5.
- 57 Kim SI, Bresnick EH. Transcriptional control of erythropoiesis: emerging mechanisms and principles. *Oncogene*. 2007 Oct 15;26(47):6777-94.
- 58 Crispino JD. GATA1 in normal and malignant hematopoiesis. *Semin Cell Dev Biol*. 2005 Feb;16(1):137-47.
- 59 Cantor AB, Orkin SH. Transcriptional regulation of erythropoiesis: an affair involving multiple partners. *Oncogene*. 2002 May 13;21(21):3368-76.
- 60 Zhang P, Zhang X, Iwama A, Yu C, Smith KA, Mueller BU, Narravula S, Torbett BE, Orkin SH, Tenen DG. PU.1 inhibits GATA-1 function and erythroid differentiation by blocking GATA-1 DNA binding. *Blood*. 2000 Oct 15;96(8):2641-8.
- 61 Ohneda K, Yamamoto M. Roles of hematopoietic transcription factors GATA-1 and GATA-2 in the development of red blood cell lineage. *Acta Haematol*. 2002;108(4):237-45.
- 62 Migliaccio AR, Rana RA, Vannucchi AM, Manzoli FA. Role of GATA-1 in normal and neoplastic hemopoiesis. *Ann N Y Acad Sci*. 2005 Jun;1044:142-58.
- 63 Jiménez G, Griffiths SD, Ford AM, Greaves MF, Enver T. Activation of the beta-globin locus control region precedes commitment to the erythroid lineage. *Proc Natl Acad Sci U S A*. 1992 Nov 15;89(22):10618-22.
- 64 Tsang AP, Visvader JE, Turner CA, Fujiwara Y, Yu C, Weiss MJ, Crossley M, Orkin SH. FOG, a multitype zinc finger protein, acts as a cofactor for transcription factor GATA-1 in erythroid and megakaryocytic differentiation. *Cell*. 1997 Jul 11;90(1):109-19.
- 65 Vakoc CR, Letting DL, Gheldof N, Sawado T, Bender MA, Groudine M, Weiss MJ, Dekker J, Blobel GA. Proximity among distant regulatory elements at the beta-globin locus requires GATA-1 and FOG-1. *Mol Cell*. 2005 Feb 4;17(3):453-62.
- 66 Swiers G, Patient R, Loose M. Genetic regulatory networks programming hematopoietic stem cells and erythroid lineage specification. *Dev Biol*. 2006 Jun 15;294(2):525-40.
- 67 Massari ME, Murre C. Helix-loop-helix proteins: regulators of transcription in eucaryotic organisms. *Mol Cell Biol*. 2000 Jan;20(2):429-40.
- 68 Porcher C, Swat W, Rockwell K, Fujiwara Y, Alt FW, Orkin SH. The T cell leukemia oncoprotein SCL/tal-1 is essential for development of all hematopoietic lineages. *Cell*. 1996 Jul 12;86(1):47-57.

-
- 69 Vyas P, McDevitt MA, Cantor AB, Katz SG, Fujiwara Y, Orkin SH. Different sequence requirements for expression in erythroid and megakaryocytic cells within a regulatory element upstream of the GATA-1 gene. *Development*. 1999 Jun;126(12):2799-811.
- 70 D'Souza SL, Elefanty AG, Keller G. SCL/Tal-1 is essential for hematopoietic commitment of the hemangioblast but not for its development. *Blood*. 2005 May 15;105(10):3862-70.
- 71 Lacaud G, Robertson S, Palis J, Kennedy M, Keller G. Regulation of hemangioblast development. *Ann N Y Acad Sci*. 2001 Jun;938:96-107.
- 72 Schranzhofer M, Schifrer M, Cabrera JA, Kopp S, Chiba P, Beug H, Müllner EW. Remodeling the regulation of iron metabolism during erythroid differentiation to ensure efficient heme biosynthesis. *Blood*. 2006 May 15;107(10):4159-67.
- 73 Jones S. An overview of the basic helix-loop-helix proteins. *Genome Biol*. 2004;5(6):226. Review.
- 74 Murre C, McCaw PS, Baltimore D. A new DNA binding and dimerization motif in immunoglobulin enhancer binding, daughterless, MyoD, and myc proteins. *Cell*. 1989 Mar 10;56(5):777-83.
- 75 Massari ME, Murre C. Helix-loop-helix proteins: regulators of transcription in eucaryotic organisms. *Mol Cell Biol*. 2000 Jan;20(2):429-40.
- 76 Cho JH, Tsai MJ. Preferential posterior cerebellum defect in BETA2/NeuroD1 knockout mice is the result of differential expression of BETA2/NeuroD1 along anterior-posterior axis. *Dev Biol*. 2006 Feb 1;290(1):125-38.
- 77 Berkes CA, Tapscott SJ. MyoD and the transcriptional control of myogenesis. *Semin Cell Dev Biol*. 2005 Aug-Oct;16(4-5):585-95.
- 78 Vetter ML, Brown NL. The role of basic helix-loop-helix genes in vertebrate retinogenesis. *Semin Cell Dev Biol*. 2001 Dec;12(6):491-8.
- 79 Ochocinska MJ, Hitchcock PF. Dynamic expression of the basic helix-loop-helix transcription factor neuroD in the rod and cone photoreceptor lineages in the retina of the embryonic and larval zebrafish. *J Comp Neurol*. 2007 Jan 5;501(1):1-12.
- 80 Jones S. An overview of the basic helix-loop-helix proteins. *Genome Biol*. 2004;5(6):226.
- 81 <http://www.web-books.com/MoBio/Free/images/Ch4F6b.gif>
- 82 Jones S. An overview of the basic helix-loop-helix proteins. *Genome Biol*. 2004;5(6):226.
- 83 Murre C. Helix-loop-helix proteins and lymphocyte development. *Nat Immunol*. 2005 Nov;6(11):1079-86.
- 84 Benezra R, Davis RL, Lockshon D, Turner DL, Weintraub H. The protein Id: a negative regulator of helix-loop-helix DNA binding proteins. *Cell*. 1990 Apr 6;61(1):49-59.
- 85 Massari ME, Murre C. Helix-loop-helix proteins: regulators of transcription in eucaryotic organisms. *Mol Cell Biol*. 2000 Jan;20(2):429-40.
- 86 Murre C. Helix-loop-helix proteins and lymphocyte development. *Nat Immunol*. 2005 Nov;6(11):1079-86.

-
- 87 Murre C. Helix-loop-helix proteins and lymphocyte development. *Nat Immunol.* 2005 Nov;6(11):1079-86.
- 88 Busslinger M. Transcriptional control of early B cell development. *Annu Rev Immunol.* 2004;22:55-79.
- 89 Bain G, Maandag EC, Izon DJ, Amsen D, Kruisbeek AM, Weintraub BC, Krop I, Schlissel MS, Feeney AJ, van Roon M, et al. E2A proteins are required for proper B cell development and initiation of immunoglobulin gene rearrangements. *Cell.* 1994 Dec 2;79(5):885-92.
- 90 Zhuang Y, Soriano P, Weintraub H. The helix-loop-helix gene E2A is required for B cell formation. *Cell.* 1994 Dec 2;79(5):875-84.
- 91 Zhuang Y, Cheng P, Weintraub H. B-lymphocyte development is regulated by the combined dosage of three basic helix-loop-helix genes, E2A, E2-2, and HEB. *Mol Cell Biol.* 1996 Jun;16(6):2898-905.
- 92 Lazorchak AS, Wojciechowski J, Dai M, Zhuang Y. E2A promotes the survival of precursor and mature B lymphocytes. *J Immunol.* 2006 Aug 15;177(4):2495-504.
- 93 Anderson MK. At the crossroads: diverse roles of early thymocyte transcriptional regulators. *Immunol Rev.* 2006 Feb;209:191-211.
- 94 Bain G, Cravatt CB, Loomans C, Alberola-Ila J, Hedrick SM, Murre C. Regulation of the helix-loop-helix proteins, E2A and Id3, by the Ras-ERK MAPK cascade. *Nat Immunol* 2001;2:165-171.
- 95 Rivera RR, Johns CP, Quan J, Johnson RS, Murre C. Thymocyte selection is regulated by the helix-loop-helix inhibitor protein, Id3. *Immunity* 2000;12: 17-26.
- 96 Bain G, Engel I, Robanus Maandag EC, te Riele HP, Volland JR, Sharp LL, Chun J, Huey B, Pinkel D, Murre C. E2A deficiency leads to abnormalities in alphabeta T-cell development and to rapid development of T-cell lymphomas. *Mol Cell Biol.* 1997 Aug;17(8):4782-91.
- 97 Barndt RJ, Dai M, Zhuang Y. Functions of E2A-HEB heterodimers in T-cell development revealed by a dominant negative mutation of HEB. *Mol Cell Biol.* 2000 Sep;20(18):6677-85.
- 98 Qiu Y, Sharma A, Stein R. p300 mediates transcriptional stimulation by the basic helix-loop-helix activators of the insulin gene. *Mol Cell Biol.* 1998 May;18(5):2957-64.
- 99 Bradney C, Hjelmeland M, Komatsu Y, Yoshida M, Yao TP, Zhuang Y. Regulation of E2A activities by histone acetyltransferases in B lymphocyte development. *J Biol Chem.* 2003 Jan 24;278(4):2370-6.
- 100 Zhang J, Kalkum M, Yamamura S, Chait BT, Roeder RG. E protein silencing by the leukemogenic AML1-ETO fusion protein. *Science.* 2004 Aug 27;305(5688):1286-9.
- 101 Zhang J, Kalkum M, Yamamura S, Chait BT, Roeder RG. E protein silencing by the leukemogenic AML1-ETO fusion protein. *Science.* 2004 Aug 27;305(5688):1286-9.
- 102 Massari ME, Jennings PA, Murre C. The AD1 transactivation domain of E2A contains a highly conserved helix which is required for its activity in both *Saccharomyces cerevisiae* and mammalian cells. *Mol Cell Biol.* 1996 Jan;16(1):121-9.
- 103 Davis JN, McGhee L, Meyers S. The ETO (MTG8) gene family. *Gene.* 2003 Jan 16;303:1-10.

-
- 104 Zhang J, Kalkum M, Yamamura S, Chait BT, Roeder RG. E protein silencing by the leukemogenic AML1-ETO fusion protein. *Science*. 2004 Aug 27;305(5688):1286-9.
- 105 Wang J, Hoshino T, Redner RL, Kajigaya S, Liu JM. ETO, fusion partner in t(8;21) acute myeloid leukemia, represses transcription by interaction with the human N-CoR/mSin3/HDAC1 complex. *Proc Natl Acad Sci U S A*. 1998 Sep 1;95(18):10860-5.
- 106 Davis JN, McGhee L, Meyers S. The ETO (MTG8) gene family. *Gene*. 2003 Jan 16;303:1-10.
- 107 Choi Y, Elagib KE, Goldfarb AN. AML-1-ETO-Mediated erythroid inhibition: new paradigms for differentiation blockade by a leukemic fusion protein. *Crit Rev Eukaryot Gene Expr*. 2005;15(3):207-16.
- 108 Goardon N, Lambert JA, Rodriguez P, Nissaire P, Herblot S, Thibault P, Dumenil D, Strouboulis J, Romeo PH, Hoang T. ETO2 coordinates cellular proliferation and differentiation during erythropoiesis. *Embo J* 2006; 25:357-66.
- 109 Brunet de la Grange P, Armstrong F, Duval V, Rouyez MC, Goardon N, Romeo PH, Pflumio F. Low SCL/TAL1 expression reveals its major role in adult hematopoietic myeloid progenitors and stem cells. *Blood*. 2006 Nov 1;108(9):2998-3004.
- 110 Palomero T, Odom DT, O'Neil J, Ferrando AA, Margolin A, Neuberg DS, Winter SS, Larson RS, Li W, Liu XS, Young RA, Look AT. Transcriptional regulatory networks downstream of TAL1/SCL in T-cell acute lymphoblastic leukemia. *Blood*. 2006 Aug 1;108(3):986-92.
- 111 O'Neil J, Shank J, Cusson N, Murre C, Kelliher M. TAL1/SCL induces leukemia by inhibiting the transcriptional activity of E47/HEB. *Cancer Cell*. 2004 Jun;5(6):587-96.
- 112 Goardon N, Lambert JA, Rodriguez P, Nissaire P, Herblot S, Thibault P, Dumenil D, Strouboulis J, Romeo PH, Hoang T. ETO2 coordinates cellular proliferation and differentiation during erythropoiesis. *EMBO J*. 2006 Jan 25;25(2):357-66.
- 113 Meier N, Krpic S, Rodriguez P, Strouboulis J, Monti M, Krijgsveld J, Gering M, Patient R, Hostert A, Grosveld F. Novel binding partners of Ldb1 are required for haematopoietic development. *Development*. 2006 Dec;133(24):4913-23.
- 114 Swiers G, Patient R, Loose M. Genetic regulatory networks programming hematopoietic stem cells and erythroid lineage specification. *Dev Biol*. 2006 Jun 15;294(2):525-40.
- 115 Elnitski L, Miller W, Hardison R. Conserved E boxes function as part of the enhancer in hypersensitive site 2 of the beta-globin locus control region. Role of basic helix-loop-helix proteins. *J Biol Chem*. 1997 Jan 3;272(1):369-78.
- 116 Milot E, Strouboulis J, Trimborn T, Wijgerde M, de Boer E, Langeveld A, Tan-Un K, Vergeer W, Yannoutsos N, Grosveld F, Fraser P. Heterochromatin effects on the frequency and duration of LCR-mediated gene transcription. *Cell*. 1996 Oct 4;87(1):105-14.

-
- 117 Strouboulis J, Dillon N, Grosveld F. Developmental regulation of a complete 70-kb human beta-globin locus in transgenic mice. *Genes Dev.* 1992 Oct;6(10):1857-64.
- 118 Yan W, Young AZ, Soares VC, Kelley R, Benezra R, Zhuang Y. High incidence of T-cell tumors in E2A-null mice and E2A/Id1 double-knockout mice. *Mol Cell Biol.* 1997 Dec;17(12):7317-27.
- 119 Yan W, Young AZ, Soares VC, Kelley R, Benezra R, Zhuang Y. High incidence of T-cell tumors in E2A-null mice and E2A/Id1 double-knockout mice. *Mol Cell Biol.* 1997 Dec;17(12):7317-27.
- 120 Nagasawa T. Microenvironmental niches in the bone marrow required for B-cell development. *Nat Rev Immunol.* 2006 Feb;6(2):107-16.
- 121 Kondo M, Weissman IL, Akashi K. Identification of clonogenic common lymphoid progenitors in mouse bone marrow. *Cell.* 1997 Nov 28;91(5):661-72.
- 122 <http://en.wikipedia.org/wiki/Apheresis>
- 123 Nervi B, Link DC, DiPersio JF. Cytokines and hematopoietic stem cell mobilization. *J Cell Biochem.* 2006 Oct 15;99(3):690-705.
- 124 Bottardi S, Aumont A, Grosveld F, Milot E. Developmental stage-specific epigenetic control of human beta-globin gene expression is potentiated in hematopoietic progenitor cells prior to their transcriptional activation. *Blood* 2003; 102:3989-97.
- 125 Geisberg JV, Struhl K. Quantitative sequential chromatin immunoprecipitation, a method for analyzing co-occupancy of proteins at genomic regions in vivo. *Nucleic Acids Res.* 2004 Nov 1;32(19):e151.
- 126 Bottardi S, Aumont A, Grosveld F, Milot E. Developmental stage-specific epigenetic control of human beta-globin gene expression is potentiated in hematopoietic progenitor cells prior to their transcriptional activation. *Blood* 2003; 102:3989-97.
- 127 Luscombe NM, Austin SE, Berman HM, Thornton JM. An overview of the structures of protein-DNA complexes. *Genome Biol.* 2000;1(1).
- 128 Nuez B, Michalovich D, Bygrave A, Ploemacher R, Grosveld F. Defective haematopoiesis in fetal liver resulting from inactivation of the EKLF gene. *Nature.* 1995 May 25;375(6529):316-8.
- 129 Perkins AC, Sharpe AH, Orkin SH. Lethal beta-thalassaemia in mice lacking the erythroid CACCC-transcription factor EKLF. *Nature.* 1995 May 25;375(6529):318-22.
- 130 Sieweke MH, Graf T. A transcription factor party during blood cell differentiation. *Curr Opin Genet Dev* 1998; 8:545-51.
- 131 Orkin SH. Diversification of haematopoietic stem cells to specific lineages. *Nat Rev Genet* 2000; 1:57-64.
- 132 Busslinger M. Transcriptional control of early B cell development. *Annu Rev Immunol* 2004; 22:55-79.
- 133 Singh H, Medina KL, Pongubala JM. Contingent gene regulatory networks and B cell fate specification. *Proc Natl Acad Sci USA* 2005; 102:4949-53.

-
- 134 Morrison AM, Nutt SL, Thevenin C, Rolink A, Busslinger M. Loss-and gain-of-function mutations reveal an important role of *BSAP* (Pax-5) at the start and end of B cell differentiation. *Semin Immunol* 1998; 10:133-42.
- 135 Busslinger M. Transcriptional control of early B cell development. *Annu Rev Immunol* 2004; 22:55-79.
- 136 Singh H, Medina KL, Pongubala JM. Contingent gene regulatory networks and B cell fate specification. *Proc Natl Acad Sci USA* 2005; 102:4949-53.
- 137 Tagoh H, Ingram R, Wilson N, Salvagiotto G, Warren AJ, Clarke D, Busslinger M, Bonifer C. The mechanism of repression of the myeloid-specific *c-fms* gene by Pax5 during B lineage restriction. *Embo J* 2006; 25:1070-80.
- 138 Busslinger M, Nutt SL, Rolink AG. Lineage commitment in lymphopoiesis. *Curr Opin Immunol* 2000; 12:151-8.
- 139 Zhang P, Behre G, Pan J, Iwama A, Wara-Aswapati N, Radomska HS, Auron PE, Tenen DG, Sun Z. Negative cross-talk between hematopoietic regulators: GATA proteins repress PU.1. *Proc Natl Acad Sci USA* 1999; 96:8705-10.
- 140 Nerlov C, Querfurth E, Kulesa H, Graf T. GATA-1 interacts with the myeloid PU.1 transcription factor and represses PU.1-dependent transcription. *Blood* 2000; 95:2543-51.
- 141 Reddy VA, Iwama A, Iotzova G, Schulz M, Elsasser A, Vangala RK, Tenen DG, Hiddemann W, Behre G. Granulocyte inducer C/EBPalpha inactivates the myeloid master regulator PU.1: Possible role in lineage commitment decisions. *Blood* 2002; 100:483-90.
- 142 Dahl R, Walsh JC, Lancki D, Laslo P, Iyer SR, Singh H, Simon MC. Regulation of macrophage and neutrophil cell fates by the PU.1:C/EBPalpha ratio and granulocyte colony-stimulating factor. *Nat Immunol* 2003; 4:1029-36.
- 143 Kim J, Sif S, Jones B, Jackson A, Koipally J, Heller E, Winandy S, Viel A, Sawyer A, Ikeda T, Kingston R, Georgopoulos K. Ikaros DNA-binding proteins direct formation of chromatin remodeling complexes in lymphocytes. *Immunity* 1999; 10:345-55.
- 144 O'Neill DW, Schoetz SS, Lopez RA, Castle M, Rabinowitz L, Shor E, Krawchuk D, Goll MG, Renz M, Seelig HP, Han S, Seong RH, Park SD, Agalioi T, Munshi N, Thanos D, Erdjument-Bromage H, Tempst P, Bank A. An ikaros-containing chromatin-remodeling complex in adult-type erythroid cells. *Mol Cell Biol* 2000; 20:7572-82.
- 145 Rodriguez P, Bonte E, Krijgsveld J, Kolodziej KE, Guyot B, Heck AJ, Vyas P, de Boer E, Grosveld F, Strouboulis J. GATA-1 forms distinct activating and repressive complexes in erythroid cells. *Embo J* 2005; 24:2354-66.

-
- 146 Goardon N, Lambert JA, Rodriguez P, Nissaire P, Herblot S, Thibault P, Dumenil D, Strouboulis J, Romeo PH, Hoang T. ETO2 coordinates cellular proliferation and differentiation during erythropoiesis. *Embo J* 2006; 25:357-66.
- 147 Melnick AM, Westendorf JJ, Polinger A, Carlile GW, Arai S, Ball HJ, Lutterbach B, Hiebert SW, Licht JD. The ETO protein disrupted in t(8;21)-associated acute myeloid leukemia is a corepressor for the promyelocytic leukemia zinc finger protein. *Mol Cell Biol* 2000; 20:2075-86.
- 148 Goardon N, Lambert JA, Rodriguez P, Nissaire P, Herblot S, Thibault P, Dumenil D, Strouboulis J, Romeo PH, Hoang T. ETO2 coordinates cellular proliferation and differentiation during erythropoiesis. *Embo J* 2006; 25:357-66.
- 149 Wadman IA, Osada H, Grutz GG, Agulnick AD, Westphal H, Forster A, Rabbitts TH. The LIM-only protein Lmo2 is a bridging molecule assembling an erythroid, DNA-binding complex which includes the TAL1, E47, GATA-1 and Ldb1/NLI proteins. *Embo J* 1997; 16:3145-57.
- 150 Meier N, Krpic S, Rodriguez P, Strouboulis J, Monti M, Krijgsveld J, Gering M, Patient R, Hostert A, Grosveld F. Novel binding partners of Ldb1 are required for haematopoietic development. *Development* 2006; 133:4913-23.
- 151 Bottardi S, Aumont A, Grosveld F, Milot E. Developmental stage-specific epigenetic control of human beta-globin gene expression is potentiated in hematopoietic progenitor cells prior to their transcriptional activation. *Blood* 2003; 102:3989-97.
- 152 Kontaraki J, Chen HH, Riggs A, Bonifer C. Chromatin fine structure profiles for a developmentally regulated gene: Reorganization of the lysozyme locus before trans-activator binding and gene expression. *Genes Dev* 2000; 14:2106-22.
- 153 Bernstein BE, Mikkelsen TS, Xie X, Kamal M, Huebert DJ, Cuff J, Fry B, Meissner A, Wernig M, Plath K, Jaenisch R, Wagschal A, Feil R, Schreiber SL, Lander ES. A bivalent chromatin structure marks key developmental genes in embryonic stem cells. *Cell* 2006; 125:315-26.
- 154 Bottardi S, Aumont A, Grosveld F, Milot E. Developmental stage-specific epigenetic control of human beta-globin gene expression is potentiated in hematopoietic progenitor cells prior to their transcriptional activation. *Blood* 2003; 102:3989-97.
- 155 Bonifer C. Epigenetic plasticity of hematopoietic cells. *Cell Cycle* 2005; 4:211-4.
- 156 Li YS, Hayakawa K, Hardy RR. The regulated expression of B lineage associated genes during B cell differentiation in bone marrow and fetal liver. *J Exp Med* 1993; 178:951-60.
- 157 Melchers F, Karasuyama H, Haasner D, Bauer S, Kudo A, Sakaguchi N, Jameson B, Rolink A. The surrogate light chain in B-cell development. *Immunol Today* 1993; 14:60-8.

-
- 158 Szutorisz H, Canzonetta C, Georgiou A, Chow CM, Tora L, Dillon N. Formation of an active tissue-specific chromatin domain initiated by epigenetic marking at the embryonic stem cell stage. *Mol Cell Biol* 2005; 25:1804-20.
- 159 Bottardi S, Ross J, Pierre-Charles N, Blank V, Milot E. Lineage-specific activators affect beta-globin locus chromatin in multipotent hematopoietic progenitors. *Embo J* 2006; 25:3586-95.
- 160 Anguita E, Hughes J, Heyworth C, Blobel GA, Wood WG, Higgs DR. Globin gene activation during haemopoiesis is driven by protein complexes nucleated by GATA-1 and GATA-2. *Embo J* 2004; 23:2841-52.
- 161 Bottardi S, Ross J, Pierre-Charles N, Blank V, Milot E. Lineage-specific activators affect beta-globin locus chromatin in multipotent hematopoietic progenitors. *Embo J* 2006; 25:3586-95.
- 162 Tagoh H, Melnik S, Lefevre P, Chong S, Riggs AD, Bonifer C. Dynamic reorganization of chromatin structure and selective DNA demethylation prior to stable enhancer complex formation during differentiation of primary hematopoietic cells in vitro. *Blood* 2004; 103:2950-5.
- 163 Lefevre P, Lacroix C, Tago H, Hoogenkamp M, Melnik S, Ingram R, Bonifer C. Differentiation-dependent alterations in histone methylation and chromatin architecture at the inducible chicken lysozyme gene. *J Biol Chem* 2005; 280:27552-60.
- 164 Kontaraki J, Chen HH, Riggs A, Bonifer C. Chromatin fine structure profiles for a developmentally regulated gene: Reorganization of the lysozyme locus before trans-activator binding and gene expression. *Genes Dev* 2000; 14:2106-22.
- 165 Grosveld F, Dillon N, Higgs D. The regulation of human globin gene expression. *Baillieres Clin Haematol* 1993; 6:31-55.
- 166 Milot E, Strouboulis J, Trimborn T, Wijgerde M, de Boer E, Langeveld A, Tan-Un K, Vergeer W, Yannoutsos N, Grosveld F, Fraser P. Heterochromatin effects on the frequency and duration of LCR-mediated gene transcription. *Cell* 1996; 87:105-14.
- 167 Grosveld F. Activation by locus control regions? *Curr Opin Genet Dev* 1999; 9:152-7.
- 168 Jimenez G, Griffiths SD, Ford AM, Greaves MF, Enver T. Activation of the beta-globin locus control region precedes commitment to the erythroid lineage. *Proc Natl Acad Sci USA* 1992; 89:10618-22.
- 169 Hu M, Krause D, Greaves M, Sharkis S, Dexter M, Heyworth C, Enver T. Multilineage gene expression precedes commitment in the hemopoietic system. *Genes Dev* 1997; 11:774-85.
- 170 Delassus S, Titley I, Enver T. Functional and molecular analysis of hematopoietic progenitors derived from the aorta-gonad-mesonephros region of the mouse embryo. *Blood* 1999; 94:1495-503.
- 171 Strouboulis J, Dillon N, Grosveld F. Developmental regulation of a complete 70-kb human beta-globin locus in transgenic mice. *Genes Dev* 1992; 6:1857-64.

-
- 172 Bottardi S, Aumont A, Grosveld F, Milot E. Developmental stage-specific epigenetic control of human beta-globin gene expression is potentiated in hematopoietic progenitor cells prior to their transcriptional activation. *Blood* 2003; 102:3989-97.
- 173 Johnson KD, Christensen HM, Zhao B, Bresnick EH. Distinct mechanisms control RNA polymerase II recruitment to a tissue-specific locus control region and a downstream promoter. *Mol Cell* 2001; 8:465-71.
- 174 Blobel GA, Nakajima T, Eckner R, Montminy M, Orkin SH. CREB-binding protein cooperates with transcription factor GATA-1 and is required for erythroid differentiation. *Proc Natl Acad Sci USA* 1998; 95:2061-6.
- 175 Bottardi S, Ross J, Pierre-Charles N, Blank V, Milot E. Lineage-specific activators affect beta-globin locus chromatin in multipotent hematopoietic progenitors. *Embo J* 2006; 25:3586-95.
- 176 Hu M, Krause D, Greaves M, Sharkis S, Dexter M, Heyworth C, Enver T. Multilineage gene expression precedes commitment in the hemopoietic system. *Genes Dev* 1997; 11:774-85.
- 177 Hu M, Krause D, Greaves M, Sharkis S, Dexter M, Heyworth C, Enver T. Multilineage gene expression precedes commitment in the hemopoietic system. *Genes Dev* 1997; 11:774-85.
- 178 Bottardi S, Ross J, Pierre-Charles N, Blank V, Milot E. Lineage-specific activators affect beta-globin locus chromatin in multipotent hematopoietic progenitors. *Embo J* 2006; 25:3586-95.
- 179 Hu M, Krause D, Greaves M, Sharkis S, Dexter M, Heyworth C, Enver T. Multilineage gene expression precedes commitment in the hemopoietic system. *Genes Dev* 1997; 11:774-85.
- 180 Bottardi S, Ross J, Pierre-Charles N, Blank V, Milot E. Lineage-specific activators affect beta-globin locus chromatin in multipotent hematopoietic progenitors. *Embo J* 2006; 25:3586-95.
- 181 Armstrong JA, Bieker JJ, Emerson BM. A SWI/SNF-related chromatin remodeling complex, E-RC1, is required for tissue-specific transcriptional regulation by EKLF in vitro. *Cell* 1998; 95:93-104.
- 182 Bottardi S, Ross J, Pierre-Charles N, Blank V, Milot E. Lineage-specific activators affect beta-globin locus chromatin in multipotent hematopoietic progenitors. *Embo J* 2006; 25:3586-95.
- 183 Bottardi S, Ross J, Pierre-Charles N, Blank V, Milot E. Lineage-specific activators affect beta-globin locus chromatin in multipotent hematopoietic progenitors. *Embo J* 2006; 25:3586-95.
- 184 Bottardi S, Ross J, Pierre-Charles N, Blank V, Milot E. Lineage-specific activators affect beta-globin locus chromatin in multipotent hematopoietic progenitors. *Embo J* 2006; 25:3586-95.
- 185 Tolhuis B, Palstra RJ, Splinter E, Grosveld F, de Laat W. Looping and interaction between hypersensitive sites in the active beta-globin locus. *Mol Cell* 2002; 10:1453-65.
- 186 Armstrong JA, Bieker JJ, Emerson BM. A SWI/SNF-related chromatin remodeling complex, E-RC1, is required for tissue-specific transcriptional regulation by EKLF in vitro. *Cell* 1998; 95:93-104.
- 187 Johnson KD, Christensen HM, Zhao B, Bresnick EH. Distinct mechanisms control RNA polymerase II recruitment to a tissue-specific locus control region and a downstream promoter. *Mol Cell* 2001; 8:465-71.

-
- 188 Vieira KF, Levings PP, Hill MA, Crusselle VJ, Kang SH, Engel JD, Bungert J. Recruitment of transcription complexes to the beta-globin gene locus in vivo and in vitro. *J Biol Chem* 2004; 279:50350-7.
- 189 Szutorisz H, Dillon N, Tora L. The role of enhancers as centres for general transcription factor recruitment. *Trends Biochem Sci* 2005; 30:593-9.
- 190 Levings PP, Zhou Z, Vieira KF, Crusselle-Davis VJ, Bungert J. Recruitment of transcription complexes to the beta-globin locus control region and transcription of hypersensitive site 3 prior to erythroid differentiation of murine embryonic stem cells. *Febs J* 2006; 273:746-55.
- 191 Bottardi S, Ross J, Pierre-Charles N, Blank V, Milot E. Lineage-specific activators affect beta-globin locus chromatin in multipotent hematopoietic progenitors. *Embo J* 2006; 25:3586-95.
- 192 Vieira KF, Levings PP, Hill MA, Crusselle VJ, Kang SH, Engel JD, Bungert J. Recruitment of transcription complexes to the beta-globin gene locus in vivo and in vitro. *J Biol Chem* 2004; 279:50350-7.
- 193 Bottardi S, Ross J, Pierre-Charles N, Blank V, Milot E. Lineage-specific activators affect beta-globin locus chromatin in multipotent hematopoietic progenitors. *Embo J* 2006; 25:3586-95.
- 194 Bottardi S, Bourgoin V, Pierre-Charles N, Milot E. Onset and inheritance of abnormal epigenetic regulation in hematopoietic cells. *Hum Mol Genet* 2005; 14:493-502.
- 195 Milot E, Strouboulis J, Trimborn T, Wijgerde M, de Boer E, Langeveld A, Tan-Un K, Vergeer W, Yannoutsos N, Grosveld F, Fraser P. Heterochromatin effects on the frequency and duration of LCR-mediated gene transcription. *Cell* 1996; 87:105-14.
- 196 Milot E, Strouboulis J, Trimborn T, Wijgerde M, de Boer E, Langeveld A, Tan-Un K, Vergeer W, Yannoutsos N, Grosveld F, Fraser P. Heterochromatin effects on the frequency and duration of LCR-mediated gene transcription. *Cell* 1996; 87:105-14.
- 197 Bottardi S, Bourgoin V, Pierre-Charles N, Milot E. Onset and inheritance of abnormal epigenetic regulation in hematopoietic cells. *Hum Mol Genet* 2005; 14:493-502.
- 198 Stamatoyannopoulos G, Nienhuis A-W. Hemoglobin Switching. In: Majerus P-W and Varmus H, eds. *The Molecular Basis of Blood Diseases*. Philadelphia, Pennsylvania: Saunders; 1994; 66:105.
- 199 Bottardi S, Ross J, Pierre-Charles N, Blank V, Milot E. Lineage-specific activators affect beta-globin locus chromatin in multipotent hematopoietic progenitors. *Embo J* 2006; 25:3586-95.
- 200 Kina T, Ikuta K, Takayama E, Wada K, Majumdar AS, Weissman IL, Katsura Y. The monoclonal antibody TER-119 recognizes a molecule associated with glycophorin A and specifically marks the late stages of murine erythroid lineage. *Br J Haematol*. 2000 May;109(2):280-7.
- 201 Geisberg JV, Struhl K. Quantitative sequential chromatin immunoprecipitation, a method for analyzing co-occupancy of proteins at genomic regions in vivo. *Nucleic Acids Res*. 2004 Nov 1;32(19):e151.
- 202 Sutherland DR, Stewart AK, Keating A. CD34 antigen: molecular features and potential clinical applications. *Stem Cells*. 1993 Oct;11 Suppl 3:50-7.

-
- 203 Duarte RF, Franf DA. The synergy between stem cell factor (SCF) and granulocyte colony-stimulating factor (G-CSF): molecular basis and clinical relevance. *Leuk Lymphoma*. 2002 Jun;43(6):1179-87.
- 204 Bhanu NV, Trice TA, Lee YT, Gantt NM, Oneal P, Schwartz JD, Noel P, Miller JL. Blood. A sustained and pancellular reversal of gamma-globin gene silencing in adult human erythroid precursor cells. 2005 Jan 1;105(1):387-93.
- 205 Schuh AH, Tipping AJ, Clark AJ, Hamlett I, Guyot B, Iborra FJ, Rodriguez P, Strouboulis J, Enver T, Vyas P, Porcher C. ETO-2 associates with SCL in erythroid cells and megakaryocytes and provides repressor functions in erythropoiesis. *Mol Cell Biol*. 2005 Dec;25(23):10235-50.
- 206 Ibañez V, Sharma A, Buonamici S, Verma A, Kalakonda S, Wang J, Kadkol S, Sauntharajah Y. AML1-ETO decreases ETO-2 (MTG16) interactions with nuclear receptor corepressor, an effect that impairs granulocyte differentiation. *Cancer Res*. 2004 Jul 1;64(13):4547-54.
- 207 Geisberg JV, Struhl K. Quantitative sequential chromatin immunoprecipitation, a method for analyzing co-occupancy of proteins at genomic regions in vivo. *Nucleic Acids Res*. 2004 Nov 1;32(19):e151.
- 208 Gartner S, Kaplan HS. Long-term culture of human bone marrow cells. *Proc Natl Acad Sci U S A*. 1980 Aug;77(8):4756-9.
- 209 Berger SL. Histone modifications in transcriptional regulation. *Curr Opin Genet Dev*. 2002 Apr;12(2):142-8.
- 210 Geisberg JV, Struhl K. Quantitative sequential chromatin immunoprecipitation, a method for analyzing co-occupancy of proteins at genomic regions in vivo. *Nucleic Acids Res*. 2004 Nov 1;32(19):e151.
- 211 Yan W, Young AZ, Soares VC, Kelley R, Benezra R, Zhuang Y. High incidence of T-cell tumors in E2A-null mice and E2A/Id1 double-knockout mice. *Mol Cell Biol*. 1997 Dec;17(12):7317-27.
- 212 Geisberg JV, Struhl K. Quantitative sequential chromatin immunoprecipitation, a method for analyzing co-occupancy of proteins at genomic regions in vivo. *Nucleic Acids Res*. 2004 Nov 1;32(19):e151.
- 213 Taneyhill LA, Adams MS. Investigating regulatory factors and their DNA binding affinities through real time quantitative PCR (RT-QPCR) and chromatin immunoprecipitation (ChIP) assays. *Methods Cell Biol*. 2008;87:367-89.
- 214 Aparicio O, Geisberg JV, Struhl K. Chromatin immunoprecipitation for determining the association of proteins with specific genomic sequences in vivo. *Curr Protoc Cell Biol*. 2004 Sep;Chapter 17:Unit 17.7.
- 215 Strouboulis J, Dillon N, Grosveld F. Developmental regulation of a complete 70-kb human beta-globin locus in transgenic mice. *Genes Dev*. 1992 Oct;6(10):1857-64.
- 216 Milot E, Strouboulis J, Trimborn T, Wijgerde M, de Boer E, Langeveld A, Tan-Un K, Vergeer W, Yannoutsos N, Grosveld F, Fraser P. Heterochromatin effects on the frequency and duration of LCR-mediated gene transcription. *Cell*. 1996 Oct 4;87(1):105-14.

-
- 217 Hanrahan J, Pan L, Greenbaum S, Bradney C, Hjelmeland M, Dai M, Zhuang Y. A genetic investigation of E2A function in lymphocyte development. *Immunol Res.* 2000;22(2-3):211-22.
- 218 Murre C. Helix-loop-helix proteins and lymphocyte development. *Nat Immunol.* 2005 Nov;6(11):1079-86.
- 219 Sigvardsson M. Overlapping expression of early B-cell factor and basic helix-loop-helix proteins as a mechanism to dictate B-lineage-specific activity of the lambda5 promoter. *Mol Cell Biol.* 2000 May;20(10):3640-54.
- 220 Quong MW, Romanow WJ, Murre C. E protein function in lymphocyte development. *Annu Rev Immunol.* 2002;20:301-22.
- 221 Goardon N, Lambert JA, Rodriguez P, Nissaire P, Herblot S, Thibault P, Dumenil D, Strouboulis J, Romeo PH, Hoang T. ETO2 coordinates cellular proliferation and differentiation during erythropoiesis. *Embo J* 2006; 25:357-66.
- 222 Bottardi S, Aumont A, Grosveld F, Milot E. Developmental stage-specific epigenetic control of human beta-globin gene expression is potentiated in hematopoietic progenitor cells prior to their transcriptional activation. *Blood* 2003; 102:3989-97.
- 223 Bottardi S, Ross J, Pierre-Charles N, Blank V, Milot E. Lineage-specific activators affect beta-globin locus chromatin in multipotent hematopoietic progenitors. *Embo J* 2006; 25:3586-95.
- 224 Sutherland DR, Stewart AK, Keating A. CD34 antigen: molecular features and potential clinical applications. *Stem Cells.* 1993 Oct;11 Suppl 3:50-7.
- 225 Nervi B, Link DC, DiPersio JF. Cytokines and hematopoietic stem cell mobilization. *J Cell Biochem.* 2006 Oct 15;99(3):690-705.
- 226 Bhanu NV, Trice TA, Lee YT, Gantt NM, Oneal P, Schwartz JD, Noel P, Miller JL. Blood. A sustained and pancellular reversal of gamma-globin gene silencing in adult human erythroid precursor cells. 2005 Jan 1;105(1):387-93.
- 227 Gabbianelli M, Pelosi E, Bassano E, Labbaye C, Petti S, Rocca E, Tritarelli E, Miller BA, Valtieri M, Testa U, et al. Granulocyte-macrophage colony-stimulating factor reactivates fetal hemoglobin synthesis in erythroblast clones from normal adults. *Blood.* 1989 Dec;74(8):2657-67.
- 228 Fathallah H, Weinberg RS, Galperin Y, Sutton M, Atweh GF. Role of epigenetic modifications in normal globin gene regulation and butyrate-mediated induction of fetal hemoglobin. *Blood.* 2007 Nov 1;110(9):3391-7.
- 229 Xu WS, Parmigiani RB, Marks PA. Histone deacetylase inhibitors: molecular mechanisms of action. *Oncogene.* 2007 Aug 13;26(37):5541-52.
- 230 Dover GJ, Brusilow S, Charache S. Induction of fetal hemoglobin production in subjects with sickle cell anemia by oral sodium phenylbutyrate. *Blood.* 1994 Jul 1;84(1):339-43.
- 231 Candido EP, Reeves R, Davie JR. Sodium butyrate inhibits histone deacetylation in cultured cells. *Cell.* 1978 May;14(1):105-13.

-
- 232 Hsiao CH, Li W, Lou TF, Baliga BS, Pace BS. Fetal hemoglobin induction by histone deacetylase inhibitors involves generation of reactive oxygen species. *Exp Hematol*. 2006 Mar;34(3):264-73.
- 233 Berger SL. Histone modifications in transcriptional regulation. *Curr Opin Genet Dev*. 2002 Apr;12(2):142-8.
- 234 Agalioti T, Lomvardas S, Parekh B, Yie J, Maniatis T, Thanos D. Ordered recruitment of chromatin modifying and general transcription factors to the IFN-beta promoter. *Cell*. 2000 Nov 10;103(4):667-78.
- 235 Dilworth FJ, Fromental-Ramain C, Yamamoto K, Chambon P. ATP-driven chromatin remodeling activity and histone acetyltransferases act sequentially during transactivation by RAR/RXR *In vitro*. *Mol Cell*. 2000 Nov;6(5):1049-58.
- 236 Reinke H, Gregory PD, Hörz W. A transient histone hyperacetylation signal marks nucleosomes for remodeling at the PHO8 promoter *in vivo*. *Mol Cell*. 2001 Mar;7(3):529-38.
- 237 Bottardi S, Ross J, Pierre-Charles N, Blank V, Milot E. Lineage-specific activators affect beta-globin locus chromatin in multipotent hematopoietic progenitors. *Embo J* 2006; 25:3586-95.
- 238 Yan W, Young AZ, Soares VC, Kelley R, Benezra R, Zhuang Y. High incidence of T-cell tumors in E2A-null mice and E2A/Id1 double-knockout mice. *Mol Cell Biol*. 1997 Dec;17(12):7317-27.
- 239 Meier N, Krpic S, Rodriguez P, Strouboulis J, Monti M, Krijgsveld J, Gering M, Patient R, Hostert A, Grosveld F. Novel binding partners of Ldb1 are required for haematopoietic development. *Development*. 2006 Dec;133(24):4913-23.