



**Michigan
Technological
University**

Michigan Technological University
Digital Commons @ Michigan Tech

Dissertations, Master's Theses and Master's Reports

2017

Implantable Wireless Sensor Networks: Application to Measuring Temperature for In Vivo Detection of Infections

Praharsh Madappaly Veetil

Michigan Technological University, pmadappa@mtu.edu

Copyright 2017 Praharsh Madappaly Veetil

Recommended Citation

Madappaly Veetil, Praharsh, "Implantable Wireless Sensor Networks: Application to Measuring Temperature for In Vivo Detection of Infections", Open Access Master's Thesis, Michigan Technological University, 2017.

<https://digitalcommons.mtu.edu/etdr/356>

Follow this and additional works at: <https://digitalcommons.mtu.edu/etdr>

 Part of the [Biomedical Commons](#), [Biomedical Devices and Instrumentation Commons](#), and the [Electrical and Electronics Commons](#)

IMPLANTABLE WIRELESS SENSOR NETWORKS: APPLICATION TO
MEASURING TEMPERATURE FOR IN VIVO DETECTION OF INFECTIONS

By

Praharsh Madappaly Veetil

A THESIS

Submitted in partial fulfillment of the requirements for the degree of

MASTER OF SCIENCE

In Biomedical Engineering

MICHIGAN TECHNOLOGICAL UNIVERSITY

2017

©2017 Praharsh Madappaly Veetil

This thesis has been approved in partial fulfillment of the requirements for the Degree of
MASTER OF SCIENCE in Biomedical Engineering.

Department of Biomedical Engineering

Thesis Advisor: *Dr. Keat Ghee Ong*

Committee Member: *Dr. Bruce P. Lee*

Committee Member: *Dr. Smitha Rao*

Department Chair: *Dr. Sean J. Kirkpatrick*

Table of Contents

List of Figures	v
List of Tables.....	vi
Acknowledgements	vii
Abstract	viii
1. Introduction	1
1.1. Orthopedic Infections	1
1.2. Infection Complications	2
1.3. Infection Pathogenesis.....	3
1.4. Risk of Infection	5
1.5. Current Treatment Modalities	6
1.6. Consequence of Current Treatment Modalities.....	8
1.7. Need for an Implantable Sensor	9
1.8. Temperature Characteristic of the Body.....	11
1.9. Electrical Temperature Sensors	12
1.9.1. LM35 Temperature Sensor	12
1.9.2. Thermistor.....	13
1.10. Design Parameters	14
1.11. Focus and goals of this research project	15
1.12. Temperature Monitoring at the Infection Site	16
1.13. Animal Test Protocol	18
1.13.1 Infection Model.....	19
1.14. Conclusion	19
1.15. References.....	21
2. Design and Fabrication	25
2.1. Power Supply.....	25
2.2. Design Criteria.....	26
2.2.1 MCP1700T Linear Voltage Regulator.....	26
2.2.2 TLV-711 Linear Voltage Regulator.....	28
2.3. Voltage Divider Circuit	30

2.4.	Wireless Transmission.....	31
2.4.1	ez430-rf2500 Development Tool.....	33
2.5.	Sensor Fabrication	35
2.6.	Packaging.....	36
2.7.	Sensor Implantation.....	38
2.8.	References	39
3.	Sensor Performance.....	40
3.1	Thermistor Sensitivity	40
3.2.	Cyclic Testing.....	41
3.3.	Sensor Characteristics.....	42
3.3.1.	Bench Tests.....	43
3.3.2.	Sensor Test Data	44
3.4.	Sensor Calibration	46
3.5.	Implantation in Rats.....	47
3.6.	References	48
4.	Discussions.....	49
5.	Conclusion	53
5.1.	References	55

List of Figures

Figure 1.1 A 47 k Ω NTC chip thermistor 1mm in length.	14
Figure 1.2 Image of the thermistor based sensor embedded inside the bone screw and attached to wire leads which connect it with the circuit board	18
Figure 1.3 The circuit is packaged in 3D printed boxes and the circuit is completely enclosed inside the structure.	18
Figure 2.1 Schematic of MCP1700 voltage regulator	28
Figure 2.2 Schematic of TLV-711 Linear Voltage Regulator	29
Figure 2.3 ez430-RF2500 wireless development tool	34
Figure 2.4 Thermistor connected by wire leads and the sensor embedded in a screw.	36
Figure 3.1 Thermistor voltage vs temperature plot.....	41
Figure 3.2 (a) The change in thermistor voltage when temperature was cycled between 35 °C to 40 °C. The actual temperature was also measured with a temperature sensor (LM35) and superimposed in the plot for comparison purposes.....	42
Figure 3.3 The response of the temperature sensor T1 inside an incubator.	45
Figure 3.4. Temperature response of T2 internal and external sensors.	46

List of Tables

Table 3.1 Timing from the sensors.	43
Table 3.2 Updated-timing constants.	43
Table 3.3 Timing from the sensors	44
Table 3.4 Updated timing constants.....	44
Table 3.5 Calibration constsnrs.....	47
Table 4.1 Device voltage drain characteristics.	52

Acknowledgements

I would like to thank my advisor, Dr. Keat Ghee Ong for believing in me and providing me with full support and guidance throughout the research work. I would like to sincerely thank my committee members, Dr. Bruce P. Lee and Dr. Smitha Rao, and with all the faculty members in the Biomedical Engineering department for their teaching, help, and support. I also want to acknowledge the research team in Georgia Tech, GA, USA, for their contributions to my research work.

A special thanks to my family for their patience, support and understanding, without which this would not have been possible. My mother and my brother, to whom I dedicate my work, have always encouraged me in my pursuit of education, dreams and happiness. I would also like to thank all my other friends for their love and care towards me, encouragement and helping me during my stressful times.

Abstract

It has been proven that infection in the body causes a local temperature increase due to localized inflammation. Therefore, a method to provide early diagnostic or long-term tracking of this infection will provide great benefits to patients with diabetic foot ulcers or sickle cell disease, and those receiving hemodialysis where they suffer from a weakened immune system. The goal of this project is to develop an implantable wireless temperature sensor based on a wireless sensor network system for monitoring infections *in situ*. The analog signals from the thermistors are digitized and wirelessly transmitted to a computer with an ez430-rf2500 wireless sensor network (Texas Instruments). The sensor device is designed to monitor temperature at a fixation plate of a rodent under an infection model. Two prototypes of the system, T1 and T2, were designed and fabricated during this work. The sensors displayed good sensitivity, stability and reliability during the testing. The system was optimized for better timing accuracy to allow power management. Such a sensor could be used for long term monitoring of infections associated with orthopedic implants.

1. Introduction

1.1. Orthopedic Infections

Osteomyelitis, or infection of the bone, occurs due to the invasion of bacteria or fungi into the bone [1]. The infections can happen immediately post-surgery or during the course of a long-term treatment. If left untreated, these infections can permanently impair the structure and function of the bone. Typically, the path of infections are through the bloodstream or along the surrounding tissues [2]. In other cases, the infections can start at the bone itself, which is more often when the injured bone is exposed due to fracture. A bone fracture can happen due to a high force impact (trauma), osteoporosis or some types of cancer such as osteosarcoma and chondrosarcoma [3]. Between 2001 and 2016, the prevalence of musculoskeletal procedures had drastically increased in the US from 16.9% to 24.2% of all the operating room procedures in hospitals. Osteoporosis affects an estimated 75 million people in the US, Europe and Japan, and is recognized as the leading cause of bone defects [4]. The bone needs to recover to its full strength, sensitivity and movement. Depending upon the degree of damage, various invasive and noninvasive treatment methods have been proposed. A common complication that has been observed during any mode of treatment is osteomyelitis, where bacteria resistant to localized immune responses infect the exposed site. Organisms invade the area of injury, wound or cut which can lead to infections in the bones. Typically, the infections persist until the implants are removed from the body. The current treatment for orthopedic infections involves hospitalization, the use of long-term course of antibiotics and surgical interventions. Therefore, there is a need for early detection and diagnosis for such infections [5]. The most common cause of such infections are *Staphylococcus aureus* bacteria [6]. Modern

methods of orthopedic surgery and musculoskeletal research are aimed at making surgery less invasive and focusing more on improving the properties of implants.

The annual cost of treating knee and hip replacements has gone from \$320 million to \$566 million between 2001 and 2009. This number is projected to go up as high as \$1.62 billion by 2020. In this period alone, the infection rates for hip and knee replacements ranged from 2.0% to 2.4% and have been on the rise ever since [7, 8]. Implant infections have continued to grow in numbers in the last decade or so thus causing a huge economic burden in terms of rates and cost involved. These infections are proven to having an adverse effect on the patient health and the quality of life. They are a massive challenge to overcome in the field of medicine in order to provide a better post-surgical care to the patient. The morbidity, mortality and the cost of treatment associated with them has been huge. On this context, there is need for a new treatment modality for early detection and diagnosis of implant related infections through an effective collaboration between surgeons, infection specialists and microbiologists by keeping emphasis on retaining the device inside the body.

1.2. Infection Complications

Orthopedic implants are an essential component in regenerative medicine. Surgical site infections are reported to be the third most frequently reported cause of nosocomial infections, accounting for 14%-16% of all nosocomial infections [9]. Risk of Orthopedic Device Related Infections (ORDI) is greater than 1-2% even though many sophisticated treatment strategies are being adopted to prevent them from happening. Bacteria find their way into the host despite the sterile conditions and standard operating procedures, leading

to the contamination at the site [10]. Typically, the host immune defenses try to fight and eliminate such bacterial contaminations or colonization, but when a threshold is reached wherein, the immune defenses are impaired and tissue surfaces are traumatized [11, 12]. The treatment of such orthopedic device related infections is usually long term and may be involved in the removal of the device itself. The exposure to invasive medical devices have been a major risk factor in these cases. These medical devices are predisposed to infections in the body by damaging the epithelial tissues and supporting the growth of microorganisms. Infections associated with implantable devices, account for around 45% of all nosocomial infections [5], are highly resistant to antibiotics, immune defenses, and usually persist until the implant has been removed from the body. The symptoms include pain at the site, followed by fever and chillness, redness at the infection site, irritation, swelling, drainage from the area and stiffness of the limb. Infections that arise from surgical implants can lead to local tissue destruction, which is mediated via various inflammatory mediators and tissue destructive enzymes. In the case of a prolonged inflammatory response, a sub-optimal bone formation may occur. To predictably produce a sterile wound can be practically impossible to implement even under laminar airflow conditions. Thus, monitoring surgical site infection (SSI) is critical for the treatment of orthopedic conditions since infections can result in prolonged hospitalization periods, revised surgical procedures, increased use of antibiotics and rehabilitation periods for patients [9, 13, 14].

1.3. Infection Pathogenesis

Orthopedic device related infection pathogenesis is correlated with biofilm formation [15]. The host proteins inside the body fluids, such as laminin, fibrinogen,

fibronectin, collagen and a host of various other proteins, will promote the adherence of bacteria such as *Staphylococcus aureus* to bio-prosthetic surfaces [16]. When prosthetic joints are infected, the bacteria tend to grow in the form of a film via aggregation and this shields them from the immune defenses inside the body. Some other microorganisms such as *Pseudomonas aeruginosa* and *Streptococcus* mutants will produce a slime layer on the surface of the prosthetic. The bone skeleton is divided into two sections, the axial skeleton and the appendicular skeleton. Axial skeleton comprises of the skull, the vertebrae and the ribs thus acting as a core unit in the system whereas, the appendicular skeleton comprises of bones in the extremities. The different nomenclature for osteomyelitis are described below [1]:

1. Hematogenous osteomyelitis: It is associated with the vertebral region wherein the infection occurs in the metaphysis of pelvis, clavicle and other long bones. It is more common in infants and children and occurs during the long bone metaphysis. When these infections extend to the soft tissue region sinus tracts are formed [1].
2. Vertebral osteomyelitis: It affects the lumbar spine and the cervical and thoracic regions. The main sources of infection are skin, soft tissue, respiratory tract, genitourinary tracts and other dental infections. They are common in patients aged 50 or above and are rarely fatal. Patients may suffer from pain, fever, tenderness and abscess formation in the case of long-term infections [1].
3. Posttraumatic osteomyelitis: It is typically found in the tibia but it begins outside the bony cortex. It is common in adults and typically affects the tibia of the bone. It can lead to complications such as vascular disorders, which can interfere with the healing process. This type of infection tends to begin outside the body makes its

way into the medullary canal. Some of the symptoms associated with posttraumatic osteomyelitis are pain, fever, soft tissue damage and necrosis [1].

4. Contiguous-focus osteomyelitis: It is the type of infection that starts at the feet of the patient with vascular disorders and diabetes. The common factors are due to direct inoculation of bacteria following a trauma, surgery, internal fixation process, prosthetic devices, spread from soft-tissue infection or other nosocomial contaminations [1].

1.4. Risk of Infection

Osteomyelitis can be described as a disease in transition that is, the predisposed factors, causative organisms and the mode of treatment evolves with time [17]. The conditions and circumstances that can increase the chance of osteomyelitis are described below:

- i. Postoperative infection: Post-surgical infections can take place immediately after a surgery leading to pain, fever and chills. The surgical region is vulnerable to bacteria for entry into the bone. Use of antimicrobial treatment may lead to chronic infections even though it may provide short term relief to the patient [18].
- ii. Late Chronic Infections: Approximately 50% of the infections are late chronic infections with 35% accompanied by subtle signs and symptoms. These can lead to loosening of the implant. These arise within 1-2 years from surgery and can lead to function loss and pain. They respond poorly to antimicrobial treatment and mostly result in the removal of the device from the body [18].
- iii. Intravenous Drug Usage: The medical tubing can open a pathway for the germs to

enter the body and increase the general risk of infection and osteomyelitis. Some of the common examples are urinary catheters, dialysis tubing and other long-term tubing [19].

- iv. **Prosthetic Replacement:** It can occur at any time after the prosthetic replacement and shows signs of infection like fever, chills and pain when compared to late chronic infections. It is found almost exclusive to joint prosthesis and leads to a sudden abnormality in the implant functioning.
- v. Finally, conditions that tend to impair the proper functioning of the immune system such as chemotherapy, intake of corticosteroids, smoking and poorly maintained diabetes [20]. Some other factors are injury to surrounding tissues, sickle cell disease, cancer and high blood cholesterol.

1.5. Current Treatment Modalities

The joint replacement surgery, especially the hips and knees, has been very common over the past few decades as it helps in restoring the function of an arthritic individual. However, these surgeries tend to have their own complications, mainly aseptic loosening and infections. Infections are treated through surgical interventions or through anti-microbial treatment methods [21]. In patients above 55 years of age, arthroplasty has been the best choice of treatment for knee arthritis. In the case of prosthetic implants, a two-stage re-implantation process is used in treating septic prosthetic joints and involves implant removal and resection of infected tissues [22]. The antimicrobial therapy is usually done along with the surgery and is rarely successful if done alone. The most important factor involved in the selection of treatment method depends on the duration of infection.

For example, in the case of fracture fixation devices, the infections depend on the nature of the device, state of union of the bones and the patient's condition. Since the rates of infections is very low when compared to the whole statistics, the need for a standardized treatment method have not been presented or implemented.

The essential factor that regulates infection development is the formation of biofilms around the implanted devices. The most important clinical objective in the treatment of such infections would be infection cure, preventing recurrence, retaining the function and death prevention. *Staphylococcus aureus* or coagulase-negative *Staphylococci* is responsible for two thirds of all infections associated with prosthetics and are variably susceptible to antibiotics [15]. Most of the implants infected by *Staphylococcus aureus* or *Staphylococcus candida* requires surgical removal of infected implants as a therapeutic treatment. The less virulent strains of bacteria may be treated using antimicrobial therapy in conditions where the medical treatment gives an established response. In the case of early postoperative infections, immediate debridement is preferred on the onset of symptoms so that biofilm formation is disabled. On the other hand, diagnosis in a person with chronic microbial infection may be very difficult as they are unlikely to respond well to antimicrobial treatment methods and do not produce any general symptoms. In the case of surgical removal, complete extraction of all the components of implant is required and is associated with producing a better outcome when compared to retaining the implant inside the body. We can conclude that the adoption of treatment method requires a clear understanding of the pathogenesis, unambiguous diagnosis and clear understanding of the susceptibility pattern [10, 23]. In this way, the patient can be given a stable implant, diagnosis and rapid treatment of infection, which helps to reduce

patient morbidity and mortality [16].

1.6. Consequence of Current Treatment Modalities

During the first two years of a surgical interventions, infections are a major cause of revision process and instability [24]. Diagnosis solely based upon patient history and physical findings may not be accurate. These treatment modalities are not only expensive, but can cause patient trauma and long-term hospitalization. The average cost of each episode in the case of infected arthroplasty is more than \$50,000. It would be appropriate to say that the best treatment demands the best surgical strategy along with optimal antibiotic therapy tailored for specific individual patient [24]. The development of conservative methods such as stage revision, debridement without implant removal [25] and improved antimicrobial therapy with optimal pharmacokinetics for prolonged periods have helped reduce the risks to some extent. In spite of the developments in recent years, there is still a need for understanding all the variables associated with infection formation and keeping a track of them by maintaining an extensive database. The erythrocyte sedimentation rate (ESR), hematological testing data, CRP results, X-rays and bone scan results are usually not specific and may not be sufficient for accurate diagnosis. On the other hand, the sensitivity of microbiological cultures typically do not exceed 70% [16].

In an effort to improve the patient condition and state of recovery, much effort has been taken towards preventing surgical site infections over the past 15 years. Most patients prefer to have a non-invasive treatment and through appropriate treatment, the rates of cure can go up as high as 80% even while retaining the device. Further attention has been given to improving the operating standards, reducing the possibility of surgical contaminations

and reduce the occurrence of infection through perioperative antibiotics prophylaxis and patient isolation but very little improvements have been made in terms of decreased rates of infection. Therefore, many recent studies have aimed at understanding the epidemiology and pathogenesis of the infections in order to gain knowledge and have better understanding of the phenomenon [26]. Most of the study are aimed at understanding colonization of the implant, pathogenic mechanism, evasion of immune responses, nature and properties of biofilms and the formation of antibiotic resistant strains. The statistics are often lacking due to limited patient follow up procedures, change in patient location, and mortality. Given the steady growth in patient morbidity caused by post-surgical infections, the need for a control has become mandatory and equally important to biocompatibility.

1.7. Need for an Implantable Sensor

Implant associated bone infections have been posing a serious challenge in the field of orthopedic surgery due to the economic burden associated with the post-surgical procedures and their effect on the patient health and quality of life. Majority of the operating rooms are contaminated even though strict standards are followed to maintain a clean operating environment. According to the latest figures, about 2.5% of primary hip and knee arthroplasties and up to 20% of revision arthroplasties suffer from Peri-Prosthetic Joint Infection (PJI) [27]. It is emphasized that, not only knee and hip joints but also artificial joints like the orthopedic screws, rods, plates, bolts all are vulnerable to biofilm formation [28]. In recent years, the number of people who are dependent on implants for life support has substantially increased. Autonomous biofilm formation on the surface of the implant has been associated with the initiation of infection, due to the suppression of

immune response at the site. The most important knowledge about a biofilm is that its defense is impervious to elimination and resistant to elimination by long-term antimicrobial treatment methods. Minimizing bacterial adhesion and biofilm formation inhibition have been in practice for the past few years however the current treatment modalities in place have not been very responsive to the pathogenic infections. A discrepancy exists in the methods and the current techniques to fight these infections. Therefore, there is a need to develop a noninvasive, cost effective method for detection and long-term monitoring of the infections associated with orthopedic implants. The post rehabilitation period is as important to the healing process as much as the surgery. In the case of an infection, the biggest challenge is the lack of a standard methodology to assess the rate of healing and infection development. It is very important to maintain a list of variables that needs to be monitored continuously at the site so that any deviation in these normal conditions can help in early detection of infection. Temperature rise at the site of infection can be considered a parameter of interest for infection diagnosis. It is demonstrated that infection causes localized inflammation of the surrounding tissues, leading to a slight increase in the local body temperature [29]. Hence, monitoring the temperature may be a valid approach in early detection of local infections.

A variety of techniques such as fluorescence, radiochemistry, metabolic active dyes and direct enumeration using a microscope have been practiced for monitoring the biofilm formation, but none of these can be considered as an ideal technique for monitoring the biofilm development inside an animal model. The current methods in place are laborious, time consuming and would usually need the extraction of bacteria from the surface of the implant [30]. Therefore, for controlling the biofilm formation and for the better

understanding of the characteristics, we need to have a rapid, non-destructive, real time monitoring system that is reliable under clinical conditions. We need to develop a system that is capable of tackling the biofilm formation thereby ensuring diagnosis and early detection. Although other methods such as X-Rays, bone scans, and Erythrocyte sedimentation rate (ESR) are available, the effective treatment of implant related infections should rely on swiftly addressing a diagnostic parameter. In the case of implant related infections, a fast, noninvasive, cost effective technique is needed for quantitative detection and diagnosis of infection to reduce the treatment cost in patients and improve their overall wellbeing [31].

1.8. Temperature Characteristic of the Body

The human body is capable to thermally regulating itself, that is, the body is capable of maintaining a constant temperature even under varying surrounding conditions. The temperature measurement inside the body will depend on the region of measurement but the pulmonary artery temperature is considered as the gold standard in such measurements. In the human body, the hypothalamic thermoregulatory center monitors the temperature changes inside the body with the help of core thermo-receptors and similarly, at the surface through the skin thermos-receptors. The production of heat inside the body may be due to conversion of chemical energy to heat, muscular contractions and cellular oxidative metabolism. The dissipation of such heat is through vasomotor changes that regulate the blood flow. Among the individuals, the mean body temperature can differ by 0.5 °C and the daily variation would be around 0.25 °C to 0.5 °C [32] but the normal body temperature would be around 37 °C. In the human body, many receptors work together in accordance

with the various system parameters to maintain a thermally regulated state. Various methods of testing the temperature involve invasive and non-invasive methods. During the onset of an infection the body temperature may rise, causing it to produce more heat than what it is capable of dissipating. During this time, stress factors are released that will cause the central nervous system to trigger an increase in the body temperature. Glass thermometers are typically used for temperature measurements inside the body, delivered through the mouth of the patient, and for children, rectal thermometers are preferred. For continuous measurements, the thermometers and thermocouples are connected to a recording device that display the temperature [32]. Electrical thermometers are more convenient when compared to glass thermometers as they have disposable probe covers and gives a quick response [32]. Very limited research have been done to see whether, the thermometer correctly measures the hyperthermia and hypothermia in critically ill patients. A critical factor that needs to be addressed is if whether the factors that control accuracy and precision are addressed. Therefore, there is a need for new innovative methods of sensing temperature changes inside or on the surface of the body.

1.9. Electrical Temperature Sensors

1.9.1.LM35 Temperature Sensor

The LM35 is a precision integrated circuit device used to measure the temperature and generates an output voltage that is linearly proportional to the temperature. It operates over a temperature range of -55 °C to 150 °C and has low output impedance, no self-heating, produces linear response and requires no calibration, which makes it easily interfaceable with a control or readout circuitry. The LM35 temperature sensor can be

operated over a voltage range of 4 V to 30 V, which makes it ideal for various applications. For our application, a board mount 3- pin LM35 is used for calibrating the sensor data. The LM35 sensor is plotted against the sensor to test the accuracy and linear response of our temperature sensor.

1.9.2. Thermistor

Thermistors are a type of resistor, in which the electrical resistance changes with temperature. Some of the common applications for thermistors are temperature sensing in self-regulating heating elements, over-current protectors, and current limiting circuits. Thermistors are broadly classified into two different types: NTC thermistors and PTC thermistors. Negative Temperature Coefficient (NTC) thermistors are those in which the resistance decrease with the increase in the temperature and Positive Temperature Coefficient (PTC) thermistors are those that increase the resistance with temperature. Thermistors for different applications are selected based on their size, types and values. They are usually made out of ceramic or polymers and they achieve a greater precision in comparison to resistance temperature detectors [24]. For our application, a 47 k Ω NTC thermistor acts as the sensing element, embedded inside a 4mm long plastic screw for sensing the temperature inside the body. Some of the advantages of using thermistor-based sensors are:

- They have a greater resistance change with temperature and very good resolution.
- They provide very good stability and repeatability.
- They have fast responses and good interchangeability.

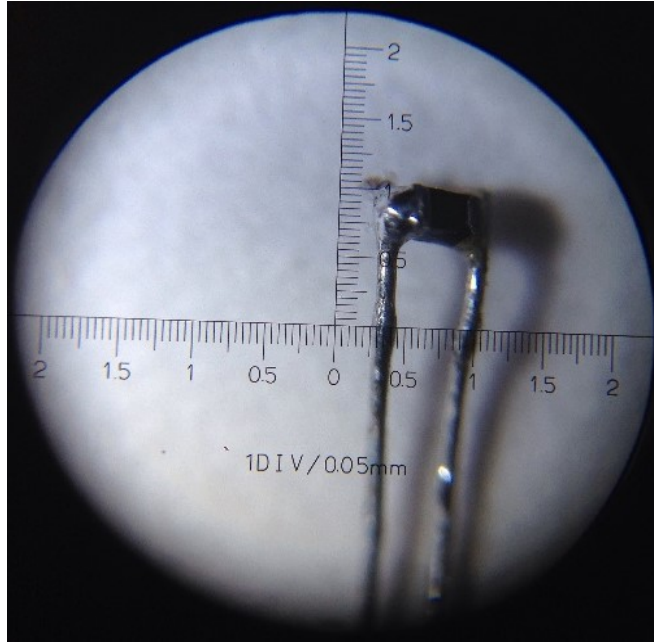

Figure 1.1 A 47 k Ω NTC chip thermistor 1mm in length.

The relationship between the resistance and the temperature of thermistors can be expressed using the equation:

$$\Delta R = k \times \Delta T \quad (1.1)$$

Where k is the proportionality constant of the thermistor and is negative for NTC thermistors, ΔR is the change in resistance and ΔT is the change in temperature measured in degree Celsius.

1.10. Design Parameters

When selecting the materials for implanting inside an animal, different parameters have to be considered such as:

- i. *Size*: The sensor system discussed here is designed for use inside a rat model. The entire sensor electronic system should be small enough to be surgically implanted inside the rat's abdominal cavity. The sensor should also be small enough so that

they can be embedded inside the bone screw and placed at the site of infection (critical size defect at a femur).

- ii. *Mechanical Strength*: The whole circuit and sensor are packaged inside a 3D printed box made from PLA (Poly-lactic acid). The box is screwed on top, and then conformal sealed with a biocompatible epoxy so that there is no leakage of body fluids into the box. The box should have good mechanical strength so it does not break and damage the circuit inside whenever the animal is in motion.
- iii. *Sensitivity*: The resistance of a thermistor will vary with temperature. The thermistor value should be selected such that they give optimum sensitivity when placed inside a bone screw. Therefore, a 47 k Ω NTC thermistor was used since it provided a very good sensitivity, resolution, and reliability.
- iv. *Data Transmission*: The implant was embedded inside the peritoneal cavity of the animal (rat). Texas Instrument's ez430rf2500, which consists of a microcontroller *MSP430F2274* and a wireless communication chip CC2500, was used for continuous data transmission from inside the body to a PC.
- v. *Battery life*: The animal tests are designed to be carried out over a period of 3-5 days. Battery characteristic and the drain values should be analyzed to ensure that the battery remains functional during the test. The circuit runs on 3.6 V non-rechargeable Li-Ion cell and was selected for its size and power rating.

1.11. Focus and goals of this research project

The focus of this project is to design an implantable wireless temperature sensor to quantitatively monitor the shift in local temperature during an infection development. The

main objectives of our work are listed below:

- i. To fabricate a sensor system to analyze the temperature characteristics at the implant site during an infection using a thermistor based sensing system consisting of both an internal and an external sensor. The external sensor will need to measure the temperature at the infection site and the internal sensor will measure the temperature at the control site.
- ii. To evaluate the sensor performance, stability of the sensor and reliability of the sensor.

1.12. Temperature Monitoring at the Infection Site

In this system, a wireless implantable temperature sensor system is designed to monitor the temperature variations inside an animal model directly exposed to an infectious state. The sensor system comprises of two thermistors, a wireless communication module, a voltage divider network that supplied a regulated voltage to the circuit, and a power supply. Two 47 k Ω NTC thermistors whose electrical resistance changes with change in the temperature were used. The thermistor displays a very good response for the target temperature range (30 °C– 40 °C) with good sensitivity and stability. Each of them was 1 mm long which makes it possible to be embedded inside a bone screw 4mm in length. The accuracy of the thermistors was characterized, by measuring the slope of the temperature versus voltage. The external sensor was connected to the end of wire leads extending from the circuit board, and the internal sensor was attached to the rear end of the 3D printed box. The wires were coated with a biocompatible coating membrane which acts as an insulation and prevents them from shorting. The internal sensor was position at a distance from the

circuit to prevent any interference due to circuit heating. The voltage regulator circuit comprises of two voltage regulators TLV-711 and MCP1700T forming a voltage divider network. TLV-711 is a series of dual, low dropout voltage regulators providing regulated voltages output of 1.25 V and 2.5 V. The 1.25 V provides a virtual ground voltage to all the components in the circuit. Similarly, the MCP1770T regulators are a family of CMOS low dropout (LDO) voltage regulators that can deliver a constant output voltage of 2.5 V to the microprocessor. The circuit comes with an over-current protection and thermal surge protection feature that shuts off the device whenever there is a surge current and restarts it when the normal conditions are restored. The 1 μ f capacitors in the circuit ensure regulator stability and improves the transient response, noise rejection and ripple response of the system. An unregulated power supply of 3.6 V through a non-rechargeable Li-ion battery cell was used to drive the system. The sensor also comprises of a wireless development tool MSP430F2274 with an ultra-low power MCU, 2.4 GHz wireless target boards and CC2500 RF transceiver for low power mode application. The prototype was tested in the lab under room temperature and followed by further tests inside an incubator at 37 °C. The values were calibrated using an LM35 temperature sensor that was placed adjacent to the thermistor.

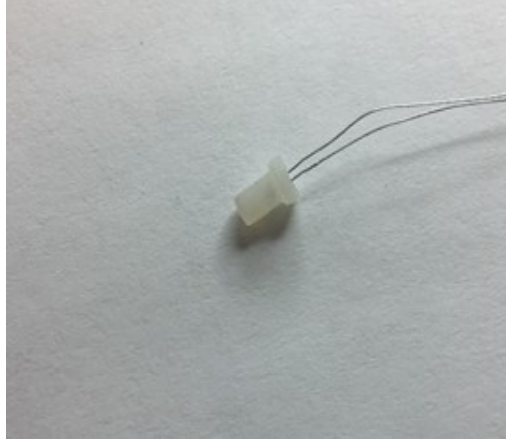

Figure 1.2 Image of the thermistor based sensor embedded inside the bone screw and attached to wire leads which connect it with the circuit board (screw is 4mm in length)

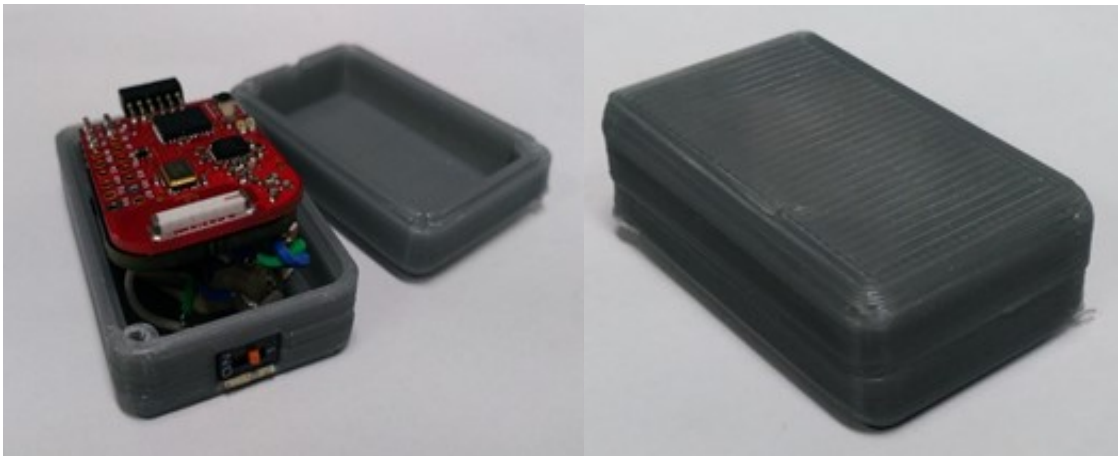

Figure 1.3 The circuit is packaged in 3D printed boxes and the circuit is completely enclosed inside the structure (4cm x 2.5cm x 1.5cm in dimension).

1.13. Animal Test Protocol

Working with small animal models on bone implants/trauma with infection can provide a deeper understanding of the bone infection, providing better information for surgeons in clinical practice. This may lead to improvement in osteomyelitis treatment strategies. In this project, two osteomyelitis rat models based on femur fracture or femur

segmental bone defects were used. We selected rat models as they offer physiologically shorter bone healing periods than larger animals. The rats in this study underwent surgical procedures under anesthesia and was monitored daily for the duration of the study. The rat was subjected to indolent infections which slowly lead to bone infections that gradually impaired the efficiency of the regenerative therapies similar to what is observed clinically.

1.13.1 Infection Model

In the model, we simulated a model of direct invasion similar to contaminated hardware that may be implanted. A single osteotomy was made in the femur to simulate a bone fracture, followed by injection of saline (no infection or control) or *Staphylococcus aureus* (Xen29 strain), which was a prominent bacterial pathogen and most frequent causal agent of infection promoted osteomyelitis into the femoral medullary canal.

The rat was a well-established model that has been used for many studies involving the implantation of tissue engineering and biomaterial scaffolds. SD (Sprague Dawley) rats approximately 13 weeks were used for the study and all the procedures were performed under aseptic conditions. The animals underwent surgery to create bone fracture and/or sensor implantation. The temperature sensor was a wireless system therefore, the animal was not aware of any data being acquired.

1.14. Conclusion

The risk of chronic infection due to a surgical procedure has substantially increased in the past decade despite improvements in surgical practices. The risk factors for infections include procedures, pre-existing infections, colonization by *Staphylococcus*

aureus, diabetes and old age. The risk of getting an infection can last up to 30 days after the surgery and can go up to one year in the case of patients that have been treated with an implant [33] and most of them are detected after they are out of the hospitals. For delayed infections, it is still unclear whether the symptoms are caused by the reaction of the implant and the soft tissue or whether it is due to the bacterial infections [7]. Chronic bacterial infections have been the major cause of late surgical infection in recent years, posing a great burden of mortality and morbidity to the patients. Due to this, the re-admission and long-term hospitalization after surgery have been increased, creating a huge economic burden to the patients and loss of productivity of the patients and their families. Therefore, the emerging technologies are required to address the issue and come up with new and innovative technologies that can aid in the diagnosis of infection at the earliest stage. The proposed sensor-based system discussed in this chapter provides a step forward in developing a miniaturized low power, wireless monitoring system that can be used to monitor the development of infection at its earliest stage.

1.15. References

1. Schierholz, J.M. and J. Beuth, *Implant infections: a haven for opportunistic bacteria*. J Hosp Infect, 2001. **49**(2): p. 87-93.
2. Andreas F. Widmer, *New Developments in Diagnosis and Treatment of Infection in Orthopedic Implants*, pp. s94 -s106, 2001.
3. R. Monina Klevens, Jonathan R. Edwards, Chesley L. Richards Jr., Teresa C. Horan, Richard Gaynes, Daniel A. Pollock, and Denise M. Cardo. *Estimating Health Care-Associated Deaths in U.S. Hospitals, 2002* .
4. Shi, C. and E.G. Pamer, *Monocyte recruitment during infection and inflammation*. Nat Rev Immunol, 2011. **11**(11): p. 762-74.
5. Lew, D.P. and F.A. Waldvogel, *Osteomyelitis*. The Lancet, 2004. **364**(9431): p. 369-379.
6. Cheng, A.G., et al., *A play in four acts: Staphylococcus aureus abscess formation*. Trends Microbiol, 2011. **19**(5): p. 225-32.
7. Jean Marie Houghton, Calin Stoicov, Sachio Nomura, Arlin B. Rogers, et-al, *Gastric Cancer Originating from Bone Marrow-Derived Cells*. pp. 1568-1571 2004
8. Rudi Schmid, *History of Viral Hepatitis: A tale of dogmas and misinterpretations*, 718-722, 2001.
9. *Staphylococcus aureus resistant to vancomycin, United States 2002*, MMWR. *Morbidity and Mortality Weekly Report*, 26; ProQuest SciTech Collection.
10. Hahn, F., R. Zbinden, and K. Min, *Late implant infections caused by Propionibacterium acnes in scoliosis surgery*. Eur Spine J, 2005. **14**(8): p. 783-8.
11. Christopher J. Palestro and Maria A. Torres, *Radionucleotide Imaging in*

Orthopedic Infections, 1997 .

12. Alicia J. Mangram, Teresa C. Horan, Michele L. Pearson, et-al, *Guidelines for Prevention of Surgical Site Infection*, 1999..
13. Campoccia, D., L. Montanaro, and C.R. Arciola, *The significance of infection related to orthopedic devices and issues of antibiotic resistance*. *Biomaterials*, 2006. **27**(11): p. 2331-9.
14. Francolini, I. and G. Donelli, *Prevention and control of biofilm-based medical-device-related infections*. *FEMS Immunol Med Microbiol*, 2010. **59**(3): p. 227-38.
15. Ferry, T., et al., *Risk factors for treatment failure in orthopedic device-related methicillin-resistant Staphylococcus aureus infection*. *Eur J Clin Microbiol Infect Dis*, 2010. **29**(2): p. 171-80.
16. Uckay, I., et al., *Prevention of surgical site infections in orthopaedic surgery and bone trauma: state-of-the-art update*. *J Hosp Infect*, 2013. **84**(1): p. 5-12.
17. Arciola, C.R., et al., *Biofilm formation in Staphylococcus implant infections. A review of molecular mechanisms and implications for biofilm-resistant materials*. *Biomaterials*, 2012. **33**(26): p. 5967-82.
18. Werner Zimmerli, Andreas F. Widmer, Marianne Blatter, et-al, *Role of Rifampin for Treatment of Orthopedic Implant- Related Staphylococcal Infections*, No. 19, *JAMA*, 1998.
19. Tice, A.D., P.A. Hoaglund, and D.A. Shoultz, *Risk factors and treatment outcomes in osteomyelitis*. *J Antimicrob Chemother*, 2003. **51**(5): p. 1261-8.
20. Daniel P. Lew and Francis A. Waldvogel, *Osteomyelitis*, *Massachusetts Medical Society*, Volume 336, No.14, 1997.

21. Parsons, B. and E. Strauss, *Surgical management of chronic osteomyelitis*. The American Journal of Surgery, 2004. **188**(1): p. 57-66.
22. Lavery, L.A., et al., *Risk factors for developing osteomyelitis in patients with diabetic foot wounds*. Diabetes Res Clin Pract, 2009. **83**(3): p. 347-52.
23. P. Sendi and W. Zimmerli *Antimicrobial treatment concepts for orthopedic device related infections*.2012.
24. Bernard, L., et al., *Trends in the treatment of orthopaedic prosthetic infections*. J Antimicrob Chemother, 2004. **53**(2): p. 127-9.
25. Rabih O. Darouchie, *Treatment of Infections Associated with Orthopedic Implants*, N EngJ Med 2004, *Massachusetts Medical Society*.
26. Rabih O. Darouchie, *Treatment of Infections Associated with Orthopedic Implants*, N EngJ Med 2004, *Massachusetts Medical Society*..
27. R. Trebse, V. Pisot, A. Trampuz, *Treatment of Infected Retained Implants*, Vol. 87-B, No.2, 2005 .
28. Lucio Montanaro, Pietro Speciale, Davide Campoccia and Stefano Ravaioli, *Scenary of Staphylococcus implant infections in orthopedics*, Future Microbiol. (2011) 6(11), 1329 -1349..
29. Lindsay, C.P., C.W. Olcott, and D.J. Del Gaizo, *ESR and CRP are useful between stages of 2-stage revision for periprosthetic joint infection*. Arthroplasty Today, 2017.
30. Winkler, H. and P. Haiden, *Treatment of Chronic Bone Infection*. Operative Techniques in Orthopaedics, 2016. **26**(1): p. 2-11.
31. Serbina, N.V. and E.G. Pamer, *Monocyte emigration from bone marrow during*

- bacterial infection requires signals mediated by chemokine receptor CCR2.* Nat Immunol, 2006. 7(3): p. 311-7.
32. Kadurugamuwa, J.L., et al., *Direct Continuous Method for Monitoring Biofilm Infection in a Mouse Model.* Infection and Immunity, 2003. 71(2): p. 882-890.
 33. Meurer, W.J., et al., *Real-time identification of serious infection in geriatric patients using clinical information system surveillance.* J Am Geriatr Soc, 2009. 57(1): p. 40-5.
 34. Victor E. Del Bene, *Temperature.*
 35. Alicia J. Mangram, Teresa C. Horan, Michele L. Pearson, et-al, *Guidelines for Prevention of Surgical Site Infection, 1999.*

2. Design and Fabrication

2.1. Power Supply

The components of the circuit must be connected to a stable and constant power supply [34]. Based on the wide range of components used in the electronic circuits, the power requirements of each component may differ. For our application, we use a 3.6 V non-rechargeable Li-ion battery cell for powering the circuit. The battery has a rated voltage of 3.6 V with a nominal capacity of 220 mAh, displays stable operation and provides excellent durability, which makes them ideal for long-term applications. Some other advantages of using a coin cell battery supply are, high energy density, long shelf life, stable operation, high rate discharge and a strong leakage resistance. For ensuring the safety of the components used in the circuit, the supply voltage should be monitored to ensure a constant regulated supply. Therefore, we used linear dropout (LDO) voltage regulators to condition the battery power. The linear dropout voltage regulators are a part of most of the electronic circuits and are a reliable source of stable voltage supply [35]. The LDO regulators have high energy efficiency which makes them the most popular class of linear regulators [34, 35]. The regulators act as variable resistors, which continuously adjust the voltage divider network to maintain a constant regulated voltage. The voltage difference between the applied voltage and the regulated voltage is dissipated in the form of heat. For the voltage regulators to function efficiently, their input voltage should be sufficiently high compared to the output and this minimum voltage is known as low drop out voltage (LDO). In our design, we use a series regulator [36] in which the power dissipated by the device is equal to the power supply output current multiplied by the voltage drop in the device. Specifically, we used two low dropout voltage regulators TLV-

711 (Texas Instruments) and MCP1700T (Texas Instruments) to carry out voltage regulation function.

2.2. Design Criteria

The TLV711 regulators are low dropout voltage regulators (LDO) with low quiescent current and provides an excellent line and load transient performance. It has an active pulldown circuit that quickly discharges the output and disables the device by pulling the enable pin down to 0 V. Also, the TLV711 has a thermal protection system which will disable its output when the junction temperature reaches around 165°C allowing the device to cool down to 145 °C before it is turned on again. This is a necessary feature to protect the implant from causing a potential harm due to thermal or power surges. Similarly, the MCP1700T chips are low dropout (LDO) voltage regulators ideal for battery powered application and consumes quiescent current as low as 1.6 μ A. It also monitors the current flowing through the pass transistor and turns the p-channel device off in case of a short circuit or during excessive output current. It also has a shutdown threshold of 140 °C. Thus, both the regulators comprise of an internal protection circuit that protects them during power or thermal surges.

2.2.1 MCP1700T Linear Voltage Regulator

The MCP1700T is under the family of CMOS low voltage dropout (LDO) voltage regulators. It can deliver up to 250 mA of current and requires an input voltage from 2.3 V to 6 V for its operation, making them ideal for battery powered applications. The input of the MCP1700T is connected to the p-channel of a p-MOS transistor. It has an operating

junction temperature between $-40\text{ }^{\circ}\text{C}$ and $125\text{ }^{\circ}\text{C}$ with a threshold at $130\text{ }^{\circ}\text{C}$. The output ranges from 1.2 V to 5 V . In the circuit, we use the 3-pin chip regulator with an input, ground and output. A part of the output voltage will be supplied to the internal error amplifier, which will compare it with the reference. This will in turn adjust the amount of current that flows through the pass transistor thus, regulating the output voltage to the desired value. The LDO also comes with overcurrent and thermal protection. In the case of any excess current flowing through the circuit the p-channel device will be turned off and will automatically restart itself after the excess current is dissipated. Similarly, if the power dissipation is high the LDO is turned off to prevent the circuit from failing. The power dissipation of the regulator IC will depend on the load current and the differential voltage between the input and the output.

The $1\text{ }\mu\text{F}$ capacitors in the circuit ensures circuit stability and small signal stability. The value of the capacitor depends on the input source type and larger values can be used to improve the AC performance. In the circuit, the 3.6 V unregulated supply from the battery is supplied to the input pin (PIN 3) of the voltage regulator IC and $1\text{ }\mu\text{f}$ capacitors are connected across the input and the ground to ensure stable functioning of the regulator. The output of the regulator (PIN 2) supplies a voltage of 2.5 V to the input port for the end device microcontroller. This will power up the end device for data transmission on to a nearby computer that receives the data. The $1\text{ }\mu\text{F}$ attached to the ground will ensure a stable output.

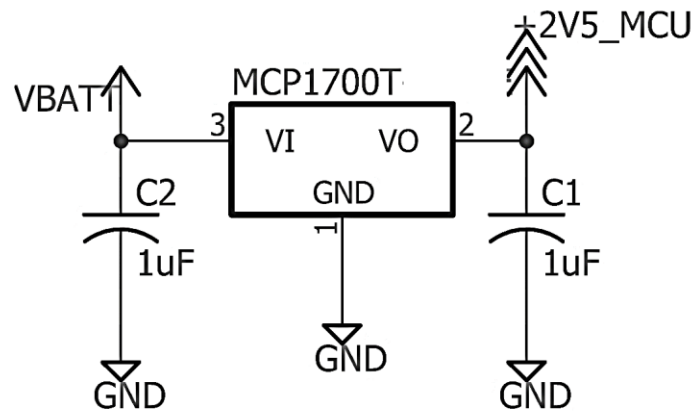

Figure 2.1 Schematic of MCP1700 voltage regulator

2.2.2 TLV-711 Linear Voltage Regulator

The TLV711 IC regulators are a series of dual, low dropout linear voltage regulators that provides an excellent line and load transient performance. TLV711 is preferred for power sensitive applications providing 2% accuracy over temperature and can regulate the input voltage even when the supply voltage is close to the input voltage. They come with an active pull down resistor that disable the EN pin in the presence of a weak or intermediate signal. TLV-711 are ideal for RF portable devices and operates at a temperature range between -40 °C to 125 °C. They are used in one, two and three battery cell applications and have a specified input voltage in the range 2.3 V to 6 V.

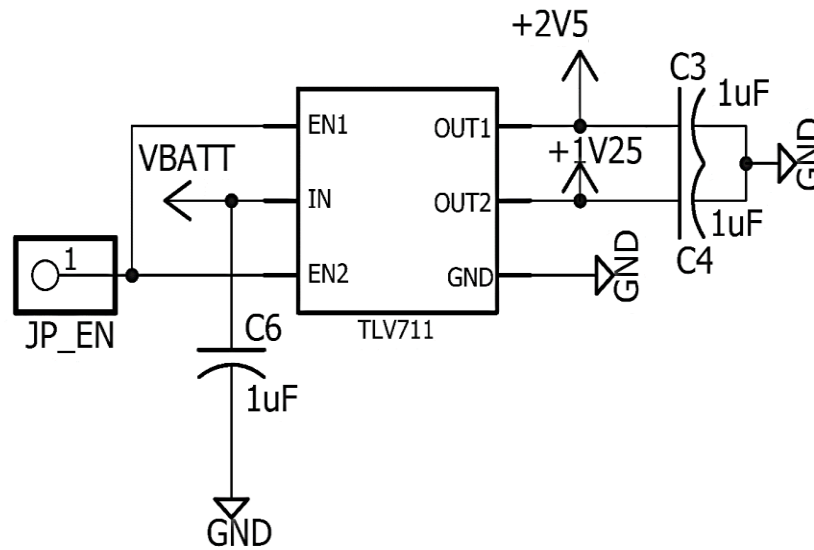

Figure 2.2 Schematic of TLV-711 Linear Voltage Regulator

For the TLV-711 regulator, the input capacitor is not necessary for stability but the $1\ \mu\text{F}$ capacitor is connected across the input and the ground to improve the transient response, noise rejection and ripple regulation. The TLV711 internal current will protect them from fault conditions. The input of the MCPP1700T is connected to the source of a p-channel p-MOS pass transistor. The PMOS pass transistor are activated in the wake of a thermal surge and they trigger a thermal shutdown before the device is turned off. When it is cooled down to operating temperatures they are again turned on by the internal thermal shutdown circuit. The TLV-711 also has an under-voltage lockout mechanism which shutoff the output when the internal circuitry is not functioning properly. The power dissipation in the circuit will depend on the input voltage supplied to the IC regulator and the existing load conditions. It can be defined as the product of the output current and the voltage drop across the output pass element. The package consists of two different voltage regulators that can provide two different output voltages at the same time. The error

amplifiers in the circuit has a voltage reference that is compared with the output from the pass transistors. During the process, a portion of the output voltage from both regulators are passed on the internal error amplifier and compared with the reference voltage. Whenever there is a change in the input voltage, the output of the error amplifier will adjust the current flowing through the pass transistor thereby getting the output voltage to the desired level. The TLV-711 uses a p-MOS pass transistor to provide the dropout voltage and it acts as a resistor in the dropout state. The error amplifiers also prevent any cross-talk interference. To turn on the device the enable pins are supplied with a minimum voltage of 0.9 V and is shutoff when the voltage goes below 0.4 V. The thermal protection system will disable the circuit output when the temperature goes above 165 °C and does not turn on until it cools to 145 °C. The power dissipation in the circuit will depend on the load current and the differential voltage between the input and the output. Thus, depending on the thermal resistance and power dissipation the circuit undergoes an ON and OFF cycle thus, protecting the circuit from damage.

An unregulated 3.6 V battery source supplies the input voltage across PIN 2, which is connected through a 1 μ F capacitor. The enable pins are shorted before connecting with the end device microcontroller. Here, the 1.25 V-regulated output from OUT1 is used to provide a virtual ground voltage for the different components in the circuit.

2.3. Voltage Divider Circuit

The voltage divider is a circuit that can turn a high voltage to a low voltage and the input is supplied across two series resistors. For a voltage divider network, the output voltage will be a fraction of the input voltage. The input voltage applied across the two

series resistors will produce a voltage drop across the second resistor, which gives the output voltage. The output voltage will be proportional to the input voltage and proportional to the ratio of the two resistors. In our design, a 3.6 V input is supplied to the input pins of the two voltage regulators MCP1700T (PIN 3) and TLV-711 (PIN 2). The 2.5 V output from the MCP1700T low dropout regulator is supplied to the input port of the microprocessor and the 1.25 V output from OUT1 of the TLV-711 is supplied to the input of the voltage divider network. The 47 k Ω thermistor and a 47 k Ω resistor are connected in series to form the voltage divider network. The output voltage is proportional to the input voltage and is supplied to the input port of the microprocessor on the end device. The current across the two series resistors will be same. The output voltage will depend on the measuring temperature, that is, when the temperature increases, the resistance in the circuit decreases which will increase the output voltage.

2.4. Wireless Transmission

The data collected from these sensor systems are wirelessly transmitted for continuous health monitoring [37]. Development of wearable health monitoring systems to access the vital signs for a patient is necessary for providing a feedback on the health status of the patient. With recent advancements in integration and miniaturization of sensors, radio interfaces and single chip embedded microcontrollers, a new generation of wireless sensor networks are being developed for various applications [37]. The sensed data can be transmitted in real-time or through a wide network [38] for collecting data sets for analysis and intervention. Several factors need to be considered before selection of a wireless transmission tool.

- i. Range: The range of a transmitter can be defined as the maximum distance between the sensor and the receiver node so that the data sent from one end reaches the receiver and is ready for extraction. The wireless transmission distance is determined by the sensitivity of the receiver and power of the transmitter.
- ii. Mode of operation: There are three different modes of transmission, basically the simplex mode, full duplex mode and the half-duplex mode. They define the flow of signals and the direction of flow. Simplex mode is unidirectional, full duplex mode is bidirectional where both the devices use channel simultaneously and half duplex is also bidirectional but the channel is used alternatively by both the devices.
- iii. Number of nodes: The nodes are used for transmitting and receiving data at both ends of the device. Some of them may be two nodes or some other can be multimode systems where there are more than two nodes. The transmission between different nodes are passed through channels and their mode of interaction needs to be defined.
- iv. Data rate: It refers to the speed at which the data is transmitted from one device to the other. It is often slow due to heat and energy consumption but they are usually low to enhance noise cancellation. This can be controlled for route-through traffic to propagate [39].
- v. Power source: Before the implantation of the device, the power drainage from the battery should be calculated. Using a wireless transceiver will consume more power from the circuit. Therefore, the selection of battery

should be in par with the test needs.

- vi. Size: For most medical healthcare applications, the wireless sensor networks are used to transmit data from wearable sensor modules attached to the body of the patient. Therefore, the transmission module has size limitation that suits its application.
- vii. Signal Interferences: Wireless interferences is inevitable even though the level can be minimized. The interferences may be physical objects, radio frequency interferences, electrical interferences or due to any other environmental factors.

Thus, before selecting a method for transmission, a clear idea of all the above-mentioned parameters need to be in place for selecting a suitable application for our device.

2.4.1 ez430-rf2500 Development Tool

The ez430-f2500 is USB based that comprises of both software and hardware for evaluating the MSP430F2274 microcontroller and a 2.5 GHz wireless transceiver. When using the ez430-RF2500, a TI's custom Integrated Development Environment (IDE), the IAR Embedded Workbench, is used to write, download and debug the application. The target board can be used as a stand-alone system or with sensors and the USB debugger interface helps in the remote data transfer from a PC. The features of the ez430-RF2500 development tool are:

- i. It has an ultra-low power microprocessor unit with 16-MHz performance.
- ii. Two digital I/O pins connected to the green and red LED's for visual feedback.

- iii. Interruptible push button switch for user feedback.
- iv. 21 pins for development applications.
- v. Driverless installation and application backchannel through a USB interface.
- vi. 200-ksps 10-bit SAR ADC.
- vii. Two built-in operational amplifiers and five low power modes that draws very small currents in low-power mode.

The target boards in the package can be integrated in to another design. The CC2500 comes with a 2.4 GHz RF transceiver, low power mode and data rates up to 500 kbps. The SimpliciTi protocol, which is a low power radio frequency protocol for small RF networks, is used to run on ultra-low power microcontrollers like the MSP430 and for multiple RF transceivers.

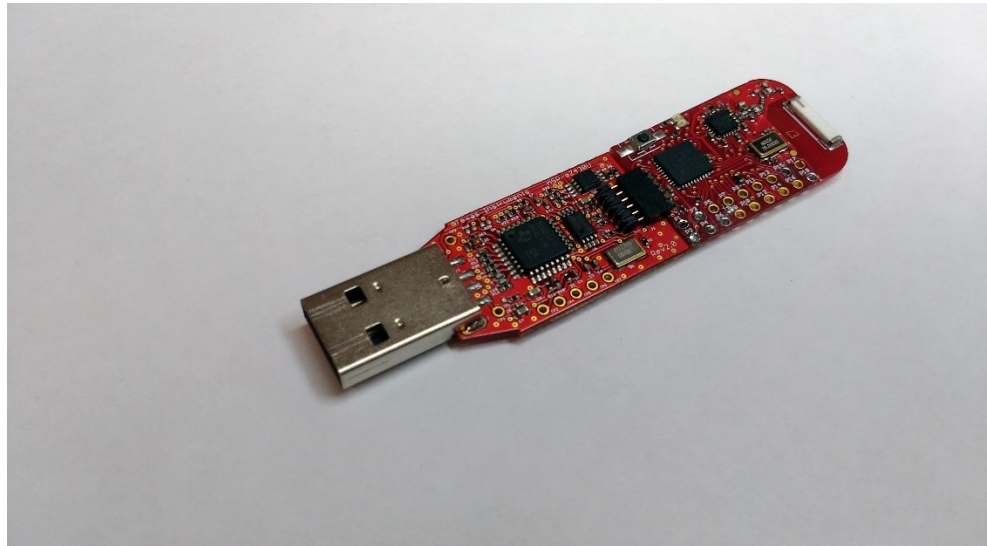

Figure 2.3 ez430-RF2500 wireless development tool

Based on the measurements, with the receiver on the PC and the transmitter on the sensor system, the indoor line of site range for the wireless transmission was measured to be more than 50 m. This range can vary with the environment and the orientation of the boards.

2.5. Sensor Fabrication

For sensor fabrication, we used a chip NTC thermistor, whose resistance will decrease with the increase in temperature. The temperature coefficient of a thermistor is defined as the fractional change in the resistance per degree Celsius change in temperature. For validating the data, sensitivity of the sensor was measured in relation to an LM35 temperature sensor, which measures the surrounding temperature and is connected to the thermistor circuit. The sensitivity with different thermistors were analyzed by collecting the response from different thermistors. The thermistor voltages were plotted against the temperature, to measure the sensor response and the relation was characterized by the B-constant (or B value). The greater the B constant, the greater the sensitivity. Thus, by analyzing the response of different thermistors, we chose a 47 k Ω thermistor for our sensor since it gave a better response compared to lower values such as the 10 k Ω thermistors. The thermistors were then connected to the circuit with the help of wire leads that attach to the ends of the thermistor. The thermistors were also connected in series with a 47 k Ω resistor together forming a voltage divider network. The size of the thermistor is critical for as they are designed to be embedded inside plastic screws before they can be implanted inside the rat model. The thermistors are 1 mm \times 0.5 mm in dimension and the screw was designed to be 4 mm in length. A polycarbonate rod was used to cut out small cylinder

shaped screws and holes will be drilled in them. The wires attached to the ends of the thermistors were insulated with a biocompatible membrane to prevent them from shorting. The thermistor attached to the leads was embedded inside the screw such that the entire thermistor was inside the screw. Also, make sure that the connection at the ends of the thermistor were not broken during the process, the bottom was glued. The internal and the external thermistors were connected to the circuit such that the external sensor collects data at the site of infection and the internal sensor collects the data in a controlled environment. The end-device connected with the board will transmit the data from both the internal and external sensors on to a computer screen. The program was run under a MATLAB

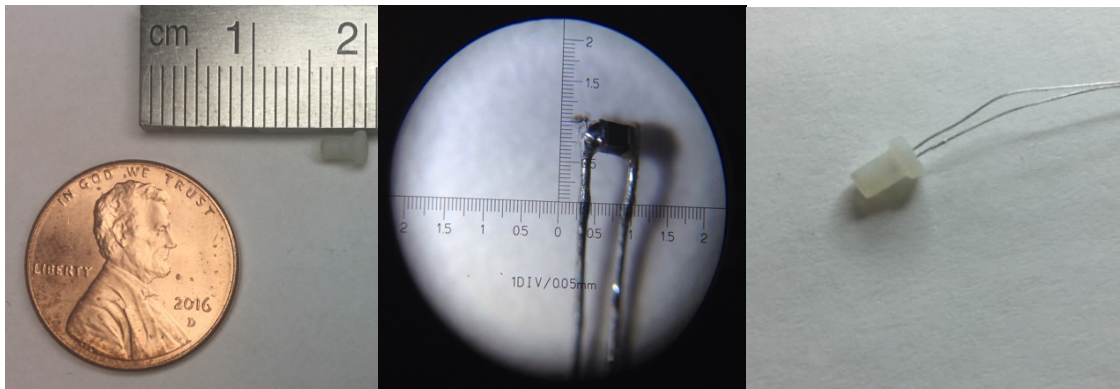

Figure 2.4 Thermistor connected by wire leads and the sensor embedded in a screw.

2.6. Packaging

The circuit that was attached to the two sensors, wireless transmission module and the power supply needed to be packed for safe handling. The circuit was protected against exposure from body fluids and mechanical strain that arose during the movement of the

animal. For this reason, we designed rectangular boxes 4 cm × 2.5 cm × 1.5 cm in dimension for holding the sensor circuit. The boxes were designed using SOLIDWORKS designing platform and printed using a 3D printer (Lulzbot Mini). The boxes were made of PLA (Poly-lactic acid) and the bottom portion of the box was designed to hold a switch for the user to turn the circuit on and off. The internal sensor was adhered to the side of the box. The top cover was then screwed. The print showed good resolution and drop tests were done to check for strength.

2.7. Sensor Implantation

The circuit board implantation and sensor wiring were placed by bone fracture surgery. Two separate skin incisions were made, one incision along the quadriceps to expose the femur, and a second to expose the abdominal cavity, the implantable circuit board was then placed inside the rat. The circuit board was approximately 25 mm in length and 15 mm thick. It was coated in silicone with the wire protruding from the silicone/board to pass from the peritoneal cavity through the incision in the abdominal musculature and runs subcutaneously to the femur. To maintain the biocompatibility of the system inside the animal, the whole system was coated with a biocompatible adhesive 1072-M (DYMAX Corporation). The 1072-M adhesive was tested in accordance to the ISO 10993 and USP Class VI. They are medical device adhesives which shows rapid bonding and are cured upon exposure to light. Compatible sterilization methods include gamma sterilization and ethylene oxide sterilization. The peritoneal cavity was then sutured closed using resorbable vicryl suture. An inoculation of 50 - 100 μ l of *S. aureus* suspension was slowly injected through a catheter in to the medullary canals of the femur. The wire connecting the sensor and circuit were assembled after the fracture. The rats were then placed on a blanket immediately after the surgery, but they remain recumbent for no more than 10 minutes. This method of anesthesia allows the animal to fully recover very quickly. The surgical wounds were observed daily to assure healing. The animals were euthanized 5 days after the initial surgery due to the effect of infection on the animal wellbeing. The end-point decision was based on the recommendation of the veterinarian in charge of the animal care facility.

2.8. References

36. Chava, C.K. and J. Silva-Martinez, *A Frequency Compensation Scheme for LDO Voltage Regulators*. IEEE Transactions on Circuits and Systems I: Regular Papers, 2004. **51**(6): p. 1041-1050.
37. Milliken, R.J., J. Silva-Martinez, and E. Sanchez-Sinencio, *Full On-Chip CMOS Low-Dropout Voltage Regulator*. IEEE Transactions on Circuits and Systems I: Regular Papers, 2007. **54**(9): p. 1879-1890.
38. Robert J. Widlar, et-al, *New Developments in IC Voltage Regulators*, IEEE Journal of Solid State Circuits, 1971.
39. Milenković, A., C. Otto, and E. Jovanov, *Wireless sensor networks for personal health monitoring: Issues and an implementation*. Computer Communications, 2006. **29**(13-14): p. 2521-2533.
40. Burns, A., et al., *SHIMMER™ – A Wireless Sensor Platform for Noninvasive Biomedical Research*. IEEE Sensors Journal, 2010. **10**(9): p. 1527-1534.
41. I.F. Akyildiz, W. Su, Y. Sankarasubramaniam and E. Cayirci, *Wireless Sensor Networks: A survey*, Georgia Institute of Technology, Atlanta, GA 30332, 2001 .

3. Sensor Performance

3.1. Thermistor Sensitivity

The thermistor should have a good sensitivity of at least $0.1\text{ }^{\circ}\text{C}$ so that it can measure any abnormal variation in the temperature during the time of infection. For the $47\text{ k}\Omega$ NTC thermistor used here, the resistance of the system will decrease with the increase in the temperature and the magnitude of the change in resistance will depend on the material used. Thermistors usually have a high sensitivity ($\sim 200\text{ }\Omega/^{\circ}\text{C}$) and are ideal for operation in the temperature range $-55\text{ }^{\circ}\text{C}$ to $114\text{ }^{\circ}\text{C}$. To test the sensor performance, the sensor was exposed to surrounding temperatures from $35\text{ }^{\circ}\text{C}$ to $40\text{ }^{\circ}\text{C}$ and the response of the sensor for the specified temperature range was recorded. To check the accuracy of the sensor, we used an LM35 temperature sensor connected to a 3.6 V battery source. The LM35 sensor recorded the real-time temperature which was measured with a digital multi-meter as voltage. The circuit was powered by a 3.6 V (Xeno XL-050F/T2 1/2 AA 3.6 V) and the circuit was switched to ON and OFF states using a toggle switch. The thermistor and LM35 were placed close to each other over a wooden base and a rectangular piece of metal on the top over which the LM35 and thermistor were taped. This metal strip was exposed to the heat using a heat lamp held at a fixed distance away from the sensor. The output of the thermistor was connected to a multi-meter via input probes and the output of the LM35 sensor was connected to a second multi-meter placed next to the other. The voltage variations of the thermistor relative to the temperature was measured with first multi-meter (Keithley 2000) and the temperature readings from the output of LM35 sensor was captured with the second multi-meter (Keithley 2001). Both multi-meters were connected to a PC for recording and analyzing the data. From the results shown below, the

thermistor produces an output DC voltage of 0.745 V at 35 °C and 0.787 V at 40 °C. The thermistor produced output voltages that were proportional to the temperature.

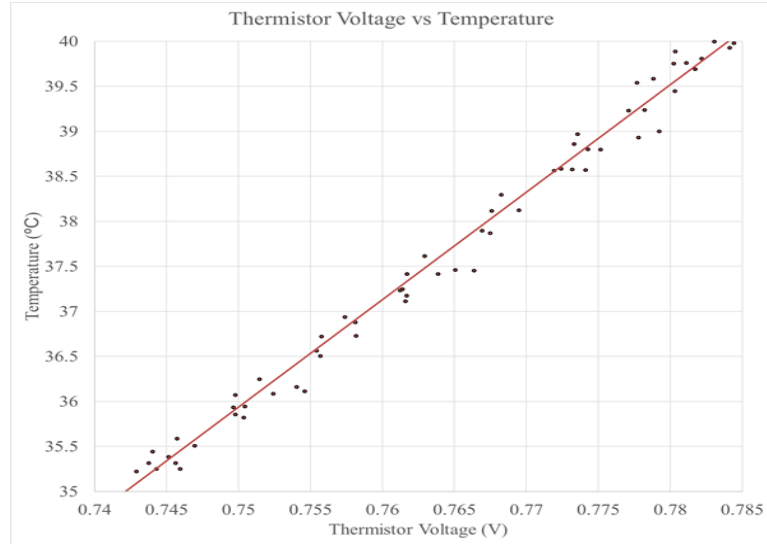

Figure 3.1 Thermistor voltage vs temperature plot.

In Figure 3.1, the thermistor voltages are plotted against the temperature. The temperature range from 35 °C – 40 °C is chosen since it resembles the temperature conditions inside the body under normal state and under an infectious state. From the plot, we can see that the thermistor produces a voltage that is proportional to the temperature and it increases linearly with the increase in the temperature. It shows a voltage reading of 0.745 V at 35 °C and goes up to 0.787 V at 40 °C.

3.2. Cyclic Testing

The cyclic tests were conducted to verify its stability and reliability of the sensor system in the long run. The sensor responses over five different cycles were analyzed and produced a stable response demonstrating good repeatability. The cyclic tests were

conducted over temperature range 35 °C to 40 °C. Also, several rigorous trials were conducted on the sensors and over higher temperature ranges from 25 °C to 40 °C for which it was able to produce a stable response.

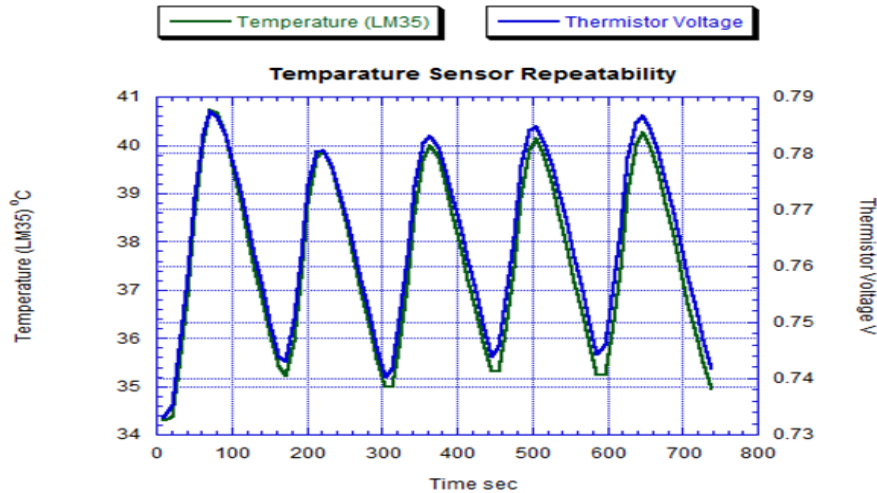

Figure 3.2 (a) The change in thermistor voltage when temperature was cycled between 35 °C to 40 °C. The actual temperature was also measured with a temperature sensor (LM35) and superimposed in the plot for comparison purposes.

3.3. Sensor Characteristics

The sensor was characterized for its sensitivity, stability and repeatability. Based on the results obtained. The end-device (ez430-rf2500) was attached to a custom board, which sent the data collected by the system to a receiver node connected to a computer. Two prototypes were fabricated to demonstrate the ability of this system to capture responses from multiple sensors simultaneously. The two prototypes were named T1 and T2 and each were connected to an end-device microcontroller wirelessly. The sensor systems were given a unique sensor ID for identification.

3.3.1. Bench Tests

The tests were conducted to determine the reliability of the sensor before animal implantation. These tests were also instrumental in determining the speed of the microcontroller for accurate timing during the ON (active) and OFF (low power mode) cycles. The microcontroller used an internal timer counter to control the ON and OFF durations. When the microcontroller was reset, the counter started counting until a pre-determined threshold (we called the threshold as the ON or OFF Timer Constants). Due to variability in the microcontroller and the temperature-dependency of the counter speed, the Timer Constants needed to be determined empirically. The Timer Constants were initialized for the different ON/OFF cycles and the program was let to run. The circuit was turned ON at room temperature (24.6 °C) and was placed inside an incubator maintained at 37 °C for characterizing the voltage variation with the change in temperature. All Timer Constants (ON/OFF) were set to 10000. The actual period for which the sensor was turned ON or OFF functional was calculated by finding the real time start/stop time and compared with the actual time to determine the calibrated ON-OFF constants.

Table 3.1 Timing from the sensors.

Sensor ID	Actual Time(s)	Sensor Time(s)	Sensor Time/Real Time (s)	Sensor Time-Real Time (s)
T1	2865.03	3600	1.25653	734.97
T2	3100.81	3600	1.16098	499.20

Table 3.2 Updated-timing constants.

New Timing Constants (S)	
T1 ON 12450	T2 ON 11570
T1 OFF	T2 OFF

12565	11610
-------	-------

The calibrated timing constants were then used to perform further testing on the sensor. A twenty-three-hour test was performed.

Table 3.3. Timing from the sensors

Sensor ID	Actual Time(s)	Sensor Time(s)	Sensor Time/Real Time (s)	Sensor Time-Real Time (s)
T1 ON	7146.05	7200	1.00754	53.95
T2 ON	7187.93	7200	1.00167	12.06
T1 OFF	53894.74	54000	1.00195	105.25
T2 OFF	53919.90	54000	1.00148	80.10

The sensor turns ON for two hours and then turns OFF after 15 hours followed by repeated one hour cycles. The Timer Constants are listed in Table 3.4.

Table 3.4 Updated timing constants.

New Timing Constants (s)	
T1 ON 12550	T2 ON 11590
T1 OFF 12588	T2 OFF 11628

3.3.2. Sensor Test Data

The data from the tests were analyzed by plotting the response of both the external and the internal sensors for both the systems T1 and T2. The voltage values for both internal and external sensors coincide at 37 °C.

During the bench tests, the ez430-RF2500 was used for wirelessly transmitting the sensor data from inside the incubator. The signal strength (RSSI) was closely monitored and maintained without any interferences. The program was downloaded on to the end-

device connected to both the sensors T1 and T2 and data is sent to the access point. The circuit for both the sensors T1 and T2 were turned ON using a switch and was run using a MATLAB GUI. The sensors T1 and T2 were turned ON initially at room temperature (24.6 °C) and then moved into an incubator, which was maintained at a controlled temperature of 37 °C. From the sensor data, the sensor shows a rise in the voltage response with gradual increase in the temperature. The two sensors in both T1 and T2 will reach a stable equilibrium at a 37 °C were the voltage response will meet at a point.

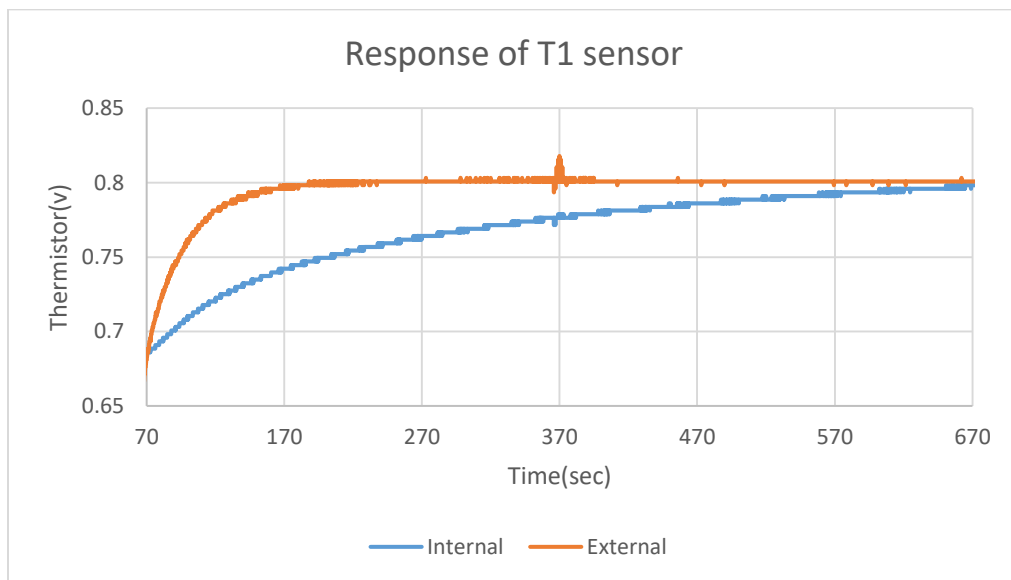

Figure 3.3 Temperature response of T1 internal and external sensors.

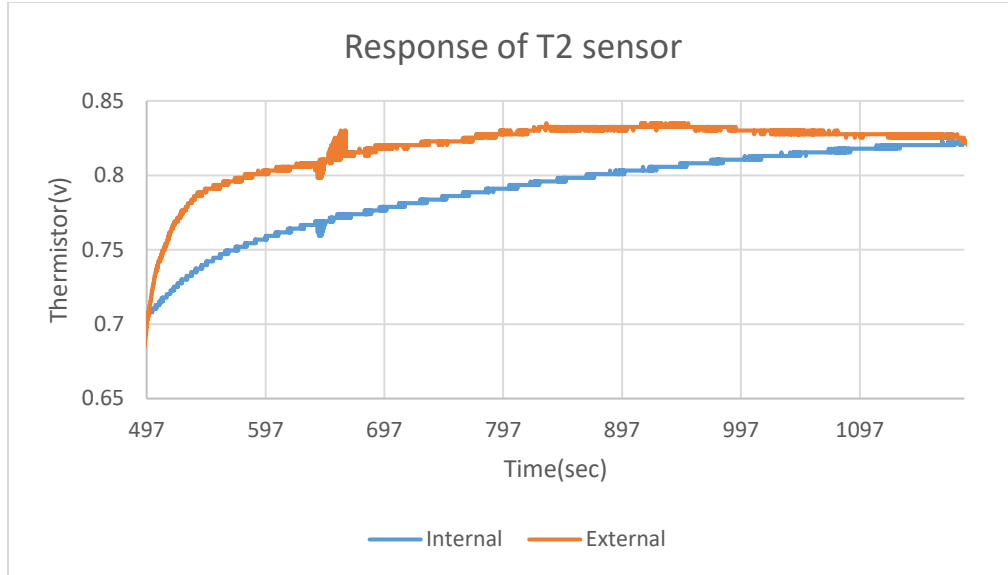

Figure 3.4. Temperature response of T2 internal and external sensors.

3.4. Sensor Calibration

An important characteristic of the thermistors used in temperature measurements is the high accuracy and high yield output of the system over a narrow temperature range [40]. The high sensitivity associated with the sensor system allows for its use in many biomedical applications. This performance of the system can be altered using the calibration equation of the thermistors. The thermistors are connected to the circuit and are exposed to different temperature values. For an NTC thermistor, the resistance decreases with increase in temperature. The resistance values are obtained over the specified temperature range. A relation between the temperature and the resistance is determined and is referred to as the calibration equation. The data for all the thermistors in both T1 and T2 were calibrated using the linear equation:

$$T = aV + b \tag{3.1}$$

Where T is the temperature in degree Celsius, V is the voltage from sensor. The constants a and b for both internal and external thermistors from T1 and T2 are listed in Table 3.4.

Table 3.5 Calibration constants

Sensor	Thermistor	<i>a</i>	<i>b</i>
T1	Internal	119.40	-53.79
T1	External	82.33	-25.96
T2	Internal	74.69	-19.08
T2	External	77.32	-21.72

3.5. Implantation in Rats

The circuit board implantation and sensor wiring were placed by bone fracture surgery. The circuit board was approximately 2.5 cm in length and 1.5 cm thick. Two different rats were used for performing the tests. The first rat was infected and the external sensor was placed at the site of infection to measure the temperature rise. The second rat was monitored under controlled conditions and were not exposed to any sort of infection. The difference in the temperature response was calculated to detect the development of infection. The surgical wounds were observed daily to assure healing.

3.6. References

42. Chen, C., *Evaluation of resistance–temperature calibration equations for NTC thermistors*. *Measurement*, 2009. **42**(7): p. 1103-1111.

4. Discussions

The sensor system demonstrated the ability to track the variation in the temperature of its surrounding during an infection. The first step in designing such a sensor system is to verify the ability of the sensor to detect the temperature variations occurring inside the body of an animal under an infectious state. In our system, we used a thermistor with a negative temperature coefficient (NTC) of resistance, which means that the resistance of the thermistor will decrease with the increase in the temperature. The resistance of the sensor was determined after several trials to determine the sensitivity with different thermistor values. A 10 k Ω thermistor initially and was replaced by a 47 k Ω thermistor for better sensitivity. The accuracy of the sensor was then checked using an LM35 temperature sensor, which was connected to thermistor circuit. The circuit was powered by a 3.6 V battery source and a switch to turn the circuit ON and OFF. The circuit comprised of a voltage divider network with two low dropout (LDO) voltage regulators, which can supply a 2.5 V-regulated voltage to the input of the microprocessor and the other has an output voltage of 1.25 V to the system components. The output of the 10 k Ω thermistor was connected to the input of a digital multimeter and the output of the LM35 temperature sensor was connected to a second digital multi-meter. Both the sensors were exposed to heating through a heat lamp and the data for the thermistor was collected in the range of 30 °C to 40 °C. By observing the slope of the linear curve, we can determine the sensitivity of the thermistor, which shows a greater sensitivity with higher slope. Similarly, tests were done for 47 k Ω thermistor and the results showed a better response for 47 k Ω compared to 10 k Ω . From Figure 3.1, we see that at 35 °C the voltage exhibited by the sensor was around 0.747 V and it went up to around 0.784 V at 40 °C. With multiple trials, the data produced

did not show any significant variation but there was slight variation in the thermistor voltage depending on the sensor and this may be attributed to the material composition of the thermistors. This temperature range was chosen to represent the normal body temperature, which is around 37 °C - 37.7 °C. So, any change in the body temperature due to an infection can cause the body temperature to rise. Therefore, by implanting the sensor at the surgical site in the body we intend to diagnose the any infection developing in the region at its earliest stage.

The most important factor to be considered while developing a system for detecting infections *in vivo* is its stability and reliability. The sensor should last over time and produce a stable response without causing any irregularities in the data. For testing the stability of the sensor, cyclic tests were carried over the temperature range from 30 °C to 40 °C and 25 °C to 40 °C. The cyclic test results shown in Figure 3.2 and Figure 3.3 was conducted in the range 30 °C - 40 °C and we can conclude that the sensor does show very good stability and repeatability over time. The thermistor had a baseline voltage of around 0.747 V at 35 °C and went up to around 0.786 V at 40 °C. After characterizing the different sensors based upon their sensitivity and stability two different prototypes of the implantable sensor was designed and named T1 and T2. The sensor was connected with the wireless device for data transmission to a nearby computer. The external thermistor in both T1 and T2 were connected using wire leads from the circuit board and the internal thermistor was attached to the printed box. The leads connecting the circuit to the external sensor were insulated using a silicone insulating membrane to prevent the wires from shorting. The internal thermistor was placed away from the circuitry and wires so that the temperature reading was not altered due to circuit heating.

After the fabrication, the sensor reliability was verified before conducting actual animal testing to check the safety and proper functioning of the device. During the test, the data for both T1 and T2 were collected for 17 hours (2 hour ON and 15 hours OFF). Both T1 and T2 were turned ON at room temperature around 24.6 °C and moved inside the incubator (37 °C) for overnight tests. The sensor T1 and T2 were packaged and the system was programmed using the IAR embedded workbench. The device continuously transmitted data from the sensors at T1 and T2 once the system was turned ON. The data indicate that the voltage from the external sensor in both T1 and T2 was higher compared to the internal sensor on the box. The response of both T1 and T2 systems were plotted from the data as shown, in Figure 3.4 and Figure 3.5, respectively. In T1, the response of the external sensor shows a higher value when compared to the internal sensor. The external sensor has a voltage reading of 0.7073 at 25 °C and both stabilize at 37 °C with a voltage reading of 0.8276 V. Similarly, the second sensor T2 will read 0.683 V at 25 °C and stabilize at 0.8081 V at 37 °C. Multiple trials were performed on T1 and T2 to monitor stability and reliability, which displayed a consistent measurement. While performing the incubator test, the temperature inside the incubator was checked to make sure that was exactly 37 °C by checking a thermometer placed inside the incubator for 5 minutes. Finally, before the system was ready for animal tests, the power characteristics of the device was analyzed. The circuit was powered by a 3.6 V non-rechargeable Li ion battery cell which has a 220 mAh. From Table 4.2, we can calculate the current drawn from the circuit for ON and OFF conditions. The voltage drain during the different ON/OFF periods were used to calculate an estimate of the battery life before they can be implanted inside the rat model. The device can remain turned ON for the entire test period which is approximately three

days.

Table 4.1 Device voltage drain characteristics.

Sensor ID	Voltage (V)			Current (mA)					
	Battery	IC1	IC2	DC Broadcast	DC ON	DC OFF	AC Broadcast	AC ON	AC OFF
T1	2.84	2.497	1.248	10	0.43	0.0036	9	2.26	0.3
T2	2.9	2.497	1.248	10	0.43	0.0036	9	2.26	0.3

The future scope of this system is to use a more advanced method of communicating the data such as the Bluetooth transmission system. The Bluetooth transmission will provide a better transmission range at a higher speed and is more user friendly. It is also suggested to have charging circuit as an alternative for the non-rechargeable battery which will help during long term studies. Using a more advanced technology such as, a charging pad should aid in producing implants in the long term.

5. Conclusion

In this study, we designed a sensor system that can effectively track the temperature variation inside a rat model in real time. The sensor electronics is designed to be implanted inside the peritoneal cavity of the rat such that the external thermistor is placed at the site of infection and the internal thermistor is placed at a controlled site. The implantable sensor can be used to detect the initiation of an infection at the site of injury or a wound by continuous monitoring of the site. It can be used to prove the hypothesis that whenever there is an infection inside the body, there is a localized temperature rise. The sensor discussed here was tested multiple times for its sensitivity, stability and reliability and results obtained proves that the sensor can effectively measure any temperature changes occurring in the body.

The use of implants has substantially increased over the past few years and alone with it comes the risk of infections. The diagnosis of infection at the site of an implant is usually based upon the clinical signs, laboratory findings and imaging techniques. Even though an estimated 5% is subject to failure due to peri-prosthetic infections, it is interesting to note that there is still no established gold standard in treating such infections. Biofilms are the cause of chronic infections due to their growth over tissues and on the surface of medical devices. Due the persistent nature and rapid progression of the pathology, it is very difficult to efficiently diagnose and suggest a treatment [41] [42]. The persisting local inflammation can be identified as the most common diagnostic feature of various biofilm based infections and they are clinically more resistant to the effects of antibiotic therapy. During the past decade or so considerable developments have happened in the diagnosis and treatment of such biofilm based infection but most of them are

incapable of detecting the infection at the early stages of its development [43]. Thus, through this work we have initiated the development of a method for detection of such infections at the site of injury by continuously monitoring the temperature at the site. The small size and low power characteristics of the sensor enable it to be attached with the medical device or any fixation devices. The data can be wirelessly transmitted to a screen for clinical purposes. The implantable sensor can be used as an alternative to conventional methods such as bioluminescence imaging [44], MRI, PCR [45] and culture techniques even though more research needs to be done on the theory before it can be used in humans [46]. The major issue that needs to be addressed is the power source, and a charging circuit is recommended for long-term applications compared to a non-rechargeable battery source. Thus, the temperature sensor displays a new and innovative method of infection diagnosis, which may be used in clinical applications.

5.1. References

43. Hoiby, N., et al., *ESCMID guideline for the diagnosis and treatment of biofilm infections 2014*. Clin Microbiol Infect, 2015. **21 Suppl 1**: p. S1-25.
44. Hall-Stoodley, L., et al., *Towards diagnostic guidelines for biofilm-associated infections*. FEMS Immunol Med Microbiol, 2012. **65**(2): p. 127-45.
45. Zimmerli, W. and P.E. Ochsner, *Management of infection associated with prosthetic joints*. Infection, 2003. **31**(2): p. 99-108.
46. Pribaz, J.R., et al., *Mouse model of chronic post-arthroplasty infection: noninvasive in vivo bioluminescence imaging to monitor bacterial burden for long-term study*. J Orthop Res, 2012. **30**(3): p. 335-40.
47. Zhou, Y.S., et al., *Nanometer resolution self-powered static and dynamic motion sensor based on micro-grated triboelectrification*. Adv Mater, 2014. **26**(11): p. 1719-24.
48. Cataldo, M.A., et al., *Prosthetic joint infection: recent developments in diagnosis and management*. J Infect, 2010. **61**(6): p. 443-8.