



**Michigan
Technological
University**

Michigan Technological University
Digital Commons @ Michigan Tech

Dissertations, Master's Theses and Master's Reports

2016

DESIGN FEATURES AND OPTIMIZATION OF PROFILE EXTRUSION DIES

Abhishek Sai Erri Pradeep
Michigan Technological University, aerripra@mtu.edu

Copyright 2016 Abhishek Sai Erri Pradeep

Recommended Citation

Erri Pradeep, Abhishek Sai, "DESIGN FEATURES AND OPTIMIZATION OF PROFILE EXTRUSION DIES", Open Access Master's Thesis, Michigan Technological University, 2016.
<https://digitalcommons.mtu.edu/etdr/166>

Follow this and additional works at: <https://digitalcommons.mtu.edu/etdr>



Part of the [Computer-Aided Engineering and Design Commons](#), and the [Manufacturing Commons](#)

DESIGN FEATURES AND OPTIMIZATION OF PROFILE EXTRUSION DIES

By

Abhishek Sai Erri Pradeep

A REPORT

Submitted in partial fulfillment of the requirements for the degree of
MASTER OF SCIENCE
In Mechanical Engineering

MICHIGAN TECHNOLOGICAL UNIVERSITY

2016

© 2016 Abhishek Sai Erri Pradeep

This report has been approved in partial fulfillment of the requirements for the Degree of
MASTER OF SCIENCE in Mechanical Engineering.

Department of Mechanical Engineering-Engineering Mechanics

Report Advisor: *Dr. Mahesh Gupta*

Committee Member: *Dr. Antonio Gauchia*

Committee Member: *Dr. Gopal Jayaraman*

Department Chair: *Dr. William W. Predebon*

Dedicated to my family and friends.

Table of Contents

1. Introduction	1
1.1 Objective	3
2. Literature Review	5
2.1 Design Challenges.....	5
2.2 Major Components of a Profile Extrusion Die	6
2.3. Design Strategies.....	7
2.3.1 Elemental Sections Method	7
3. Material Properties of Polymer	10
4. Die Optimization Methods.....	12
4.1 Manual Optimization.....	12
4.2 Automatic Optimization	14
5. Design Methodologies	18
5.1 Design Feature 1: Land length modification	18
5.1.1 Scaled-Up preland	19
5.1.2 Approach angle adjustment	23
5.1.3 Channel length adjustment	27
5.1.4 Isolated channel 1.....	30
5.1.5 Isolated channel 2.....	34
5.2 Other Unique Design Features.....	37
5.2.1 Design Feature 2: Slits	37
5.2.2 Design Feature 3: Dams.....	42
5.2.3 Design Feature 4: Pre-land flow separators	44
5.2.4 Design Feature 5: Corner Projections.....	48
5.2.5 Design Feature 6: Drafting channels	50
5.2.6 Design Feature 7: Thin land for co-extrusion	55
6. Automatic Die Optimization	61
6.1 Elemental Sections Optimization 1	61
6.2 Elemental Sections Optimization 2	67
6.3 Avoid Cross-flow Strategy 1 (Mono Extrusion)	73

6.4 Avoid Cross-flow Strategy 2 (Co-extrusion)	83
7. Summary and Recommendation	92
7.1 Conclusions.....	92
7.2 Recommendations	93
8. References	94

List of Figures

Figure 1 Extrusion line layout [1]	1
Figure 2 Cross-section of single screw extruder [2].....	2
Figure 3 Major components of a profile extrusion die.....	6
Figure 4 Major design parameters.....	8
Figure 5 Elemental Sections (ES) on the exit face.....	8
Figure 6 Polymer viscosity graph	11
Figure 7 Manual optimization procedure	13
Figure 8 Parameterization of critical features in Solidworks.....	15
Figure 9 Range definition of critical features in PolyXtrue.....	16
Figure 10 Automatic optimization procedure	17
Figure 11 Extrudate dimensions (in mm).....	19
Figure 12 3-D model of initial extrusion die	19
Figure 13 (a) Velocity plot (b) Exit deviation (c) Temperature plot in the initial die.....	21
Figure 14 CAD geometry of modified die	22
Figure 15 (a) Velocity plot (b) Exit deviation (c) Temperature plot in the final die.....	23
Figure 16 Extrudate dimensions (in mm).....	24
Figure 17 3-D model of initial extrusion die	24
Figure 18 (a) Velocity plot (b) Exit deviation measured in the initial die	25
Figure 19 CAD geometry of modified die	26
Figure 20 (a) Velocity plot (b) Exit deviation measured in the final die	26
Figure 21 Extrudate dimensions (in mm).....	27
Figure 22 3-D model of initial extrusion die	28
Figure 23 (a) Velocity plot (b) Exit deviation in the initial die	29
Figure 24 3-D model of modified extrusion die (side face made transparent to show variation in flow channel geometry).....	29
Figure 25 (a) Velocity plot (b) Exit deviation in the final die	30
Figure 26 Extrudate dimensions (in mm).....	31
Figure 27 CAD model of initial extrusion die	31
Figure 28(a) Velocity plot (b) Exit deviation measured in the initial die	32
Figure 29 3-D model of modified extrusion die.....	33
Figure 30 (a) Velocity plot (b) Exit deviation measured in the final die	33
Figure 31 Extrudate dimensions (in mm).....	34
Figure 32 CAD model of initial extrusion die	35
Figure 33(a) Velocity plot (b) Exit deviation measured in the initial die	36
Figure 34 Modified die (reduced projection length)	36
Figure 35(a) Velocity plot (b) Exit deviation measured in the final die	37

Figure 36 Extrudate dimensions (in mm).....	38
Figure 37 3-D model of initial extrusion die	38
Figure 38 (a) velocity plot (b) exit deviation (c) velocity profile cut sections in the initial die.....	40
Figure 39 (a) 3-D model of modified extrusion die (b) 3-D model of modified extrusion die outside face transparent.....	41
Figure 40 (a) Velocity plot (b) exit deviation measured (c) velocity profile cut sections in the final die.....	42
Figure 41 3-D model of modified extrusion die (side face made transparent to show the “dam”)	43
Figure 42 (a) Velocity plot (b) Exit deviation measured in the final die	44
Figure 43 Extrudate dimensions (in mm).....	45
Figure 44 (a) Velocity plot (b) CAD model of initial extrusion die	45
Figure 45 (a) Velocity plot (b) Exit deviation measured in the final die	46
Figure 46 (a), (b), (c) Modified extrusion die with pre-land flow separators	47
Figure 47(a) Velocity plot (b) Exit deviation measured in the final die	48
Figure 48 (a), (b) Modified die with projections upstream (Front face made transparent to show projections)	49
Figure 49(a) Velocity plot (b) Exit deviation in the final die	50
Figure 50 Extrudate dimensions (in mm).....	51
Figure 51 Initial extrusion die CAD model	51
Figure 52(a) Velocity plot (b) Exit deviation measured in the initial die	52
Figure 53 Flow channel design (Side faces are made transparent).....	53
Figure 54 Flow simulation showing dead spots.....	53
Figure 55 Modified die with drafting flow channel geometry.....	54
Figure 56 Flow simulation of modified die with no dead spots	54
Figure 57 Extrudate dimensions (in mm).....	55
Figure 58 CAD model of initial co-extrusion die	56
Figure 59(a) Velocity plot (b) Exit deviation measured in the initial die	57
Figure 60(a) initial velocity plot at entrance 2 cross-section (b) initial velocity vector plot at entrance 2 cross-section	57
Figure 61 Modified co-extrusion die CAD model.....	58
Figure 62(a) final velocity plot at entrance 2 cross-section (b) final velocity vector plot at entrance 2 cross-section	59
Figure 63(a) Velocity plot (b) Exit deviation measured in the final die	59
Figure 64 (a), (b) layer structure for initial die (c), (d) layer structure for final die.....	60
Figure 65 Extrudate dimensions (in mm).....	61
Figure 66 CAD model of initial extrusion die	62
Figure 67(a) Velocity plot (b) Exit deviation measured in the initial die	63

Figure 68(a) beginning of cross-flow (b) end of cross-flow	64
Figure 69 Modified die with flow separator	64
Figure 70 Prevention of cross-flow by adding a flow separator	65
Figure 71(a) Velocity plot (b) Exit deviation measured in the final die	67
Figure 72 Extrudate dimensions (in mm).....	68
Figure 73 CAD model of initial extrusion die	68
Figure 74 (a) velocity profile at the beginning of land section (b) velocity profile at exit of land section (c) exit deviation.....	70
Figure 75 CAD model of modified die.....	70
Figure 76(a) Velocity plot (b) Exit deviation measured in the final die	72
Figure 77 Extrudate dimensions (in mm).....	73
Figure 78 Die land	74
Figure 79 Division of exit face into DV's	75
Figure 80 Die pre-land.....	75
Figure 81 Pre-land flow channels.....	76
Figure 82 Transition zone.....	77
Figure 83 Adapter	77
Figure 84 Initial extrusion die	78
Table 18 Boundary conditions	79
Figure 85 Initial flow simulation results.....	79
Figure 86 Pre-land section thicknesses.....	80
Figure 87 Optimized die flow simulation results	82
Figure 88 (a) Initial die exit deviation (b) Optimized die exit deviation	83
Figure 89 Polymer viscosity graph	84
Figure 90 Initial CAD model of co-extrusion die	85
Figure 91 Initial flow simulation result	86
Figure 92 Pre-land channel modification to balance exit velocity	87
Figure 93 Optimized die flow simulation results	88
Figure 94 (a) Initial die exit deviation (b) Optimized die exit deviation	89
Figure 95 (a), (b) layer structure for initial die (c), (d) layer structure for final die.....	91

List of Tables

Table 1 Polymer properties.....	11
Table 2 Boundary conditions	20
Table 3 Boundary conditions	25
Table 4 Boundary conditions	28
Table 5 Boundary conditions	32
Table 6 Boundary Conditions.....	35

Table 7 Boundary conditions	39
Table 8 Boundary conditions	46
Table 9 Boundary conditions	52
Table 10 Boundary conditions	56
Table 11 Boundary conditions	63
Table 12 Initial parameter values	65
Table 13 Parameter ranges.....	66
Table 14 Optimized parameter values.....	66
Table 15 Boundary conditions	69
Table 16 Parameter ranges.....	71
Table 17 Optimized parameter values.....	72
Table 19 Parameter ranges.....	81
Table 20 Optimized parameter values.....	82
Table 21 Polymer properties	84
Table 22 Boundary conditions	86

Acknowledgements

I would like to thank Dr. Mahesh Gupta for trusting in my ability and providing me with an opportunity to work on a challenging project. This report could not have been possible without his vision and the constant support he provided during my research.

I would like to thank Mr. Martin Krogel for the support and guidance he provided while using the polyXtrue software.

Finally, I would like to thank my committee members Dr. Antonio Gauchia and Dr. Gopal Jayaraman for sparing their valuable time to review my work, and provide me with their valuable insights.

This work was financially supported by NSF grant number IIP-1519737.

Abstract

This report deals with design of dies used in the plastic extrusion industry. The design methodology for extrusion dies has evolved over the years with advancement of computing technology. However, the design process is still heavily dependent on the experience of the die designer, and hence is still considered to be more of an art than science.

Even for an experienced designer, the time required to design the die and perform consecutive fine tuning iterations is high. In this report, a proprietary optimization code for extrusion dies, developed by Plastic Flow LLC, was tested and shown to be advantageous over manual methods of flow balancing which are still being applied in the industry.

Also, there is no published literature discussing certain finer aspects of die design, which have proven to be successful commercially. The current work, reviews these strategies, and provides a document of design guidelines which would be useful to relatively new die design engineers.

1. Introduction

Plastic Extrusion is a continuous manufacturing process, used to produce parts which have a constant cross-section across their length. Generally, thermoplastics materials like PVC are employed in the production of these parts. Extruded plastics find application in a variety of industries ranging from construction (window frames), medical (catheter), automotive (weather strips) and a variety of other industries.



Figure 1 Extrusion line layout [1]

Polymer pellets are fed into the hopper, from where they enter the extruder by the gravity-feed mechanism.

Figure 2 shows the cross-section of a typical single screw extruder. Occasionally, twin screw extruders might also be employed when the compounding of various polymer melts is necessary.

The pellets first enter the feed section of the extruder where the screw flight is deep, and then pass onto the compression section in their solid state. In the compression section, the solid pellets are compressed and any occluded air trapped is removed. The pellets then pass onto the metering section which has the most shallow screw flight depth. The main function of the

metering section is to ensure a uniform feed rate. Over the course of this travel, the pellets are converted from solid to liquid state by the barrel heaters and heat generated due to the viscous dissipation.

The breaker plate at the end of the screw ensures that the polymer melt has minimum rotary motion and also prevents any impurities from the barrel entering the die.

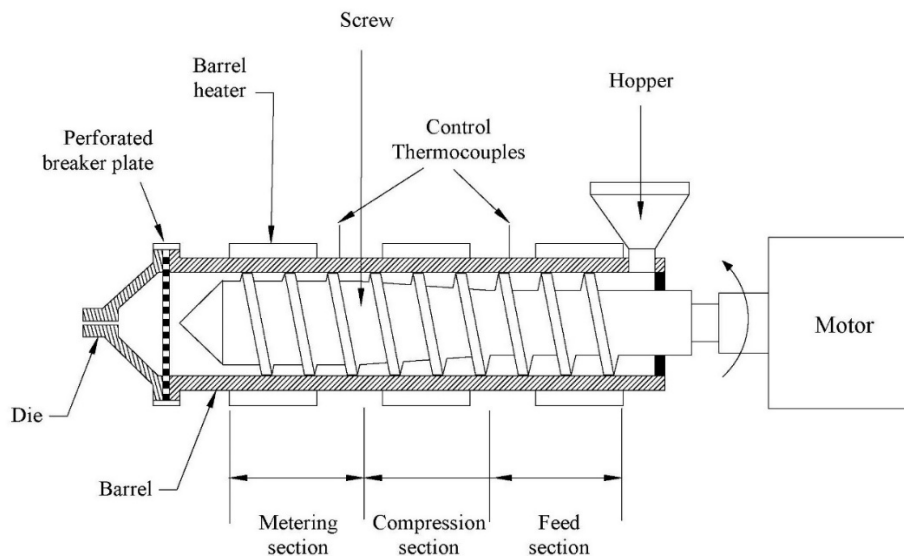

Figure 2 Cross-section of single screw extruder [2]

The extrusion die, shapes the polymer melt from a circular entrance channel into the required extrudate shape. There are various types of extrusion dies like the film, sheet, annular and other profile extrusion dies. Having a uniform velocity profile at the exit face of the die is essential to obtain a high quality product.

After exiting the die, the semi-solid extrudate enters the calibration/cooling system. In this phase the extrudate is cooled below its melting temperature by a cooling medium (generally water), and also formed into the desired shape by applying an internal pressure or an external vacuum.

During this entire cycle the extrudate is constantly pulled by a set of rollers, which are called as the haul-off unit. The haul-off unit causes a decrease in the size of the extrudate, which is caused due to the stretching action of the rollers. Draw down ratio, is the ratio of linear velocity of the haul-off system (v) to the velocity at which the extrudate emerges from the die (v_0). [3]

$$DDR=v/v_0$$

The value of the draw down ratio depends on the rate of production and the quality of part desired. A higher draw down ratio enables faster production, whereas a lower draw down ratio ensures better product tolerances.

Finally, the sawing unit is used to cut the extrudate into lengths of the required dimensions.

1.1 Objective

This report, focuses on the design aspects of profile extrusion dies, which are used to form a variety of complex extrudate shapes.

Traditionally, the design of extrusion dies involved several experimental runs, wherein a die with an approximate shape was manufactured and iteratively modified based on the quality of the extrudate. This method required highly experienced designers and was also very time consuming. It has been reported by JFT Pittman [4], that these trial and error cycles constituted half of the development costs.

With the improvement in computational power, it is now possible to run accurate flow simulations in extrusion dies by taking into account the polymer properties like viscoelasticity and elongational viscosity [5]. This has considerably reduced the die development cost and time. However, there is still a considerable aspect of die design which is dependent on the designer's experience.

To address this concern, as discussed later in the literature review section of this report, previous work has been carried out to identify the major sections of a profile extrusion die, and develop strategies to balance the flow across the exit of these dies.

However, these design strategies can be generalized only for relatively simple profile extrusion dies and they do not get into the finer aspects of the design. Also, there is a need to constantly run flow simulations and make iterative design modifications before the optimized die design is achieved.

This report, focuses on those aspects of die design which have not been covered in the literature previously. Sample dies have been modelled in Solidworks and polymer flow has been simulated through them using polyXtrue software to prove various concepts. Also, an optimization code developed by Plastic Flow LLC [6], which enables automatic die design optimization, has been tested and found to be successful in optimizing the designs of various profile extrusion dies.

This document would prove useful to relatively inexperienced die designers, in learning more about the design techniques implemented in commercial extrusion die design, and would also be relevant to industry patrons and research scholars, who are interested in learning more about the capabilities of the automatic die optimization technique, developed by Plastic Flow LLC.

In the literature review section of this document, a brief overview of the major parts of the profile extrusion die is given. Also discussed are various strategies employed to balance the flow at the exit of the die.

2. Literature Review

2.1 Design Challenges

The major challenge in designing a profile extrusion die is to obtain a uniform exit velocity profile at the exit face of the die. Non-uniform velocity profile across the exit face causes the extrudate to deform after the polymer comes out of the die.

Due to variation in wall thickness across different sections of the profile extrusion die, it is not possible to use the same die design strategies, which are implemented for products like tubes and sheets. The polymer melt tends to always flow in areas which have the least flow restriction. This causes the thicker regions of the profile die to have higher velocity (more polymer flow) as compared to the thinner regions of the die, which have a lower velocity (lesser polymer flow).

The design of extrusion dies starts with the dimensions of the extrudate which form the geometry of the exit face, and then progresses upstream to ascertain other features of the die. The primary concept employed is the reduction in thickness of the regions which feed the wider sections of the exit profile and an increase in thickness of the regions which feed the thinner sections at the exit.

2.2 Major Components of a Profile Extrusion Die

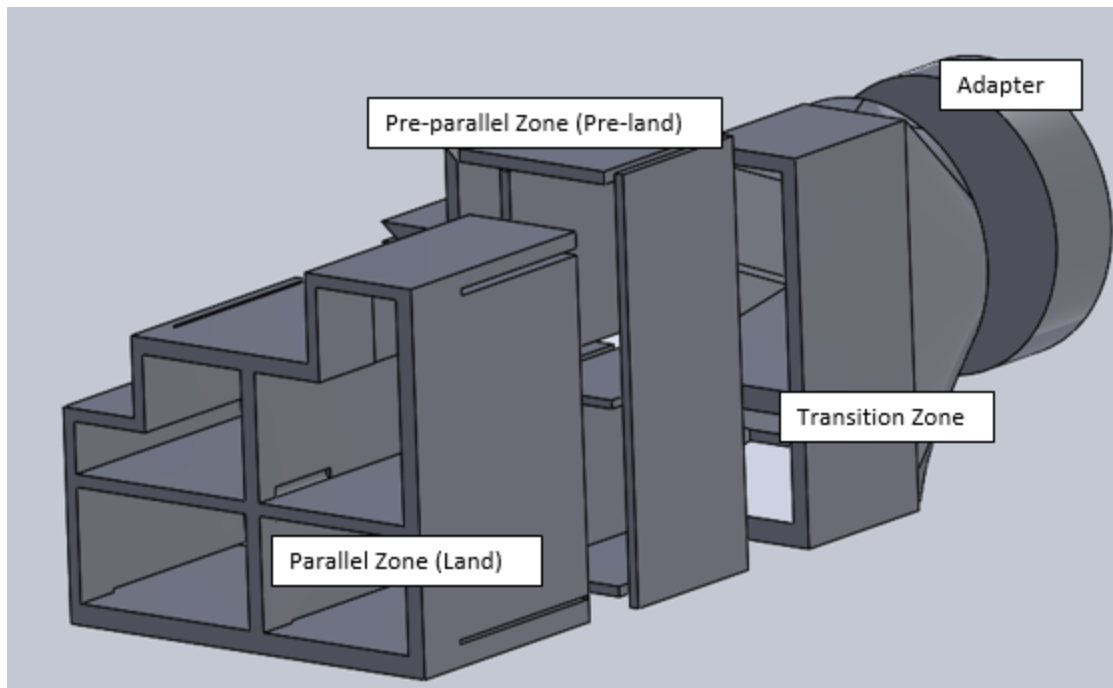

Figure 3 Major components of a profile extrusion die

J.M. Nobrega et al. [7] in their paper on flow balancing in extrusion dies, have suggested to partition the extrusion die into four major components as shown in Figure 3. A brief summary of the role of each component is provided below.

Adapter: The adapter generally has a circular cross-section and has the same diameter as that of the extruder barrel. It is used to accommodate the breaker plate and filter element. The breaker plate ensures the rotating motion of the polymer is transformed into longitudinal motion, whereas the filter element prevents any foreign particles from entering the die.

Transition zone: The transition zone modifies the polymer flow from the circular inlet into the more complex shape of the pre-parallel zone. This zone can be very simple for common geometrical shapes (square, triangle) and relatively complex for irregular profile shapes.

Pre-Parallel zone: It is a zone which is inserted prior to the parallel zone to enable local flow control. Since changes cannot be made in the wall dimensions of the parallel zone, the pre-

parallel zone provides the opportunity to balance the flow by increasing the restriction in high flow areas and decreasing the resistance in low flow area.

Parallel zone: The parallel zone of the extrusion die, has a cross-section of the desired extrudate shape. It is the narrowest region of the die and hence is responsible for a majority of the pressure drop across the die. Its main purpose is to relax the deformations in the polymer melt which have been imposed upstream, and hence reduce the magnitude of die swell, as well as the sensitivity of the extrudate shape to the change in processing conditions.

2.3. Design Strategies

Depending on the complexity of the die, different design strategies have been developed by researchers to achieve balanced flow at the exit of the die. Two commonly adopted strategies which have been used in this work are described in the following sections.

2.3.1 Elemental Sections Method

A unique method to optimize the flow balance across the exit face an extrusion die has been developed by Nobrega et al. [7]

According to this strategy, the primary focus is based on improving the design of the pre-parallel and parallel sections of the die. For instance, for the die shown in Figure 4, the major design parameters are land length L_1 , L_2 , L_3 angle of convergence (θ) and compression ratio (h_1/H_1), (h_3/H_1).

Initially, the exit face of the die is divided into elemental sections (ES) as shown in Figure 5, and one of the following methodologies is adopted.

1. DM1: finding the best ES lengths (L_1 , L_2 and L_3) in order to obtain a local average velocity equal to the global average flow velocity.
2. DM2: finding the best ES thickness in order to obtain a local ES flow rate that allows the attainment of the pre-established thickness after pulling.
3. DM3: finding the best ES thickness in order to obtain a local average velocity equal to the global average flow velocity (applicable only when final section thickness can be varied).

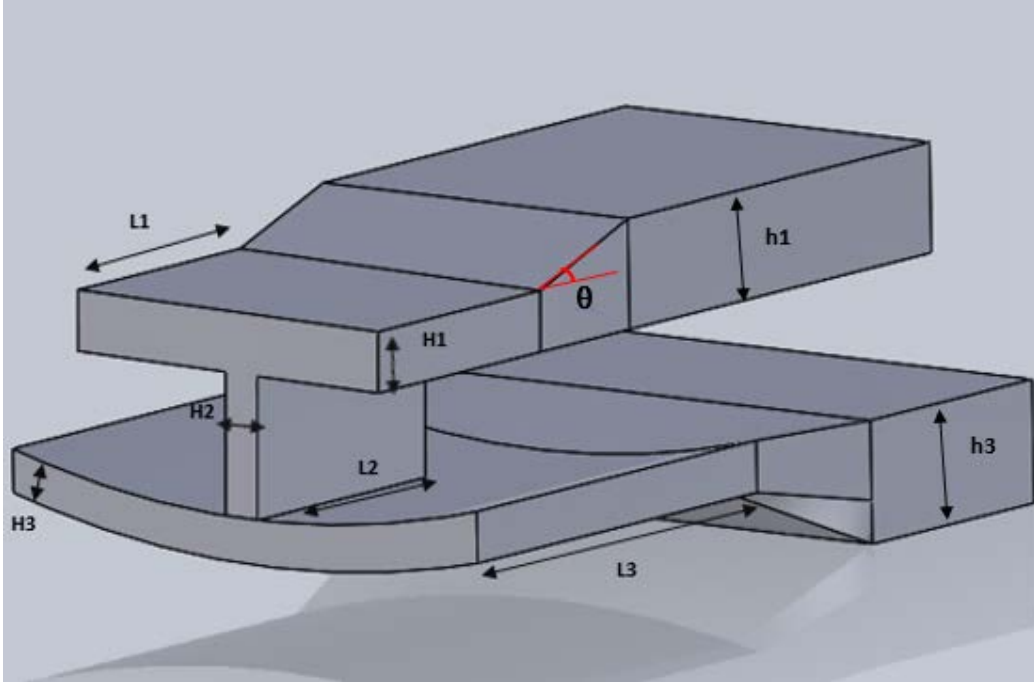

Figure 4 Major design parameters

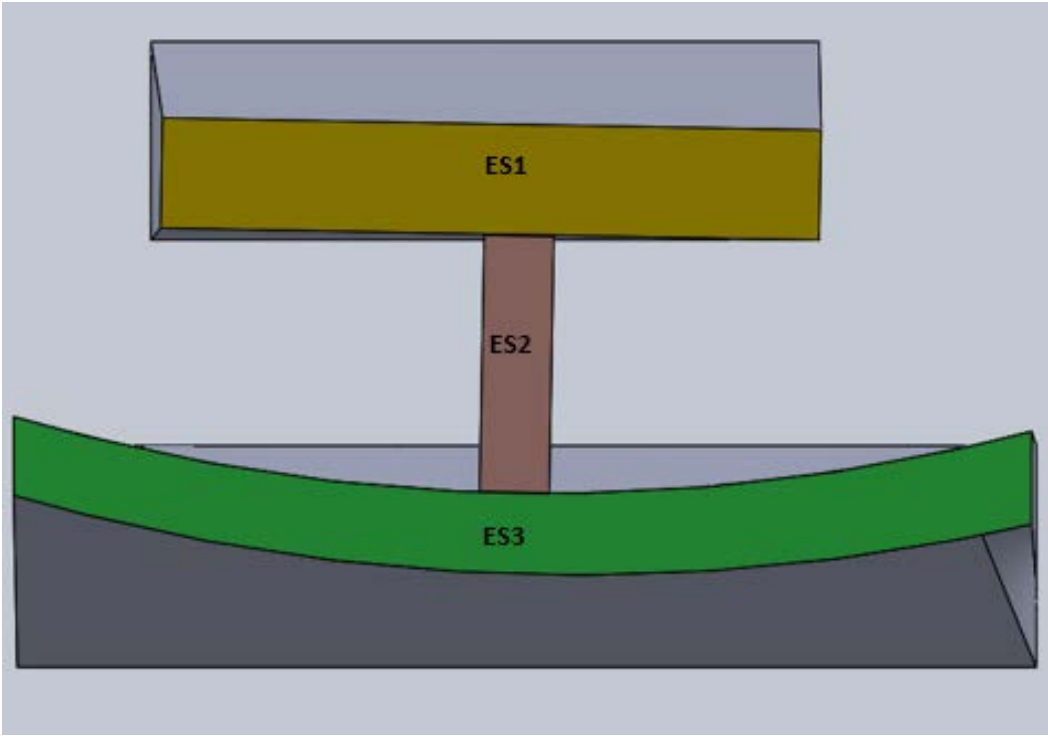

Figure 5 Elemental Sections (ES) on the exit face

After the design methodology is selected, flow simulations are run across the modified CAD geometries until uniform velocity at exit face is obtained.

Depending on the complexity of the die, land length, wall thickness or both can be optimized. However, for complex profile dies this strategy cannot be implemented due to the occurrence of cross flow between various sections of the die.

A detailed example showing the application of this strategy is discussed in the section 6 of this report.

2.3.2 Avoid Cross Flow Method

B. L. Koziy et al. have developed the "Avoid Cross Flow Strategy (ACFS)" [8] which is suitable for designing complex extrusion dies where high amounts of cross-flow is anticipated.

In this method, the final cross-section of the extrudate is divided into a number of sub-sections called design variables (DV's), and area of each DV is calculated as a percentage of the total area, which is represented by A_p . These DV's are then mapped onto other cross-sections upstream of the die. As we progress upstream, the complexity of the profile decreases and hence there are fewer number of DV's with varying values of A_p . The goal of this method, is to ensure that the fraction of flow passing through a given DV at a particular cross-section of the die is equal to the A_p value at that given cross-section.

A detailed example showing the application of this method is discussed in the section 6 of this report.

3. Material Properties of Polymer

Viscosity of a fluid is a measure of the fluid's resistance to deformation. Empirically viscosity η can be represented as,

$$\eta = \frac{\tau}{\dot{\gamma}}$$

Where τ denotes shear stress and $\dot{\gamma}$ the shear rate.

Newtonian fluids have a fixed viscosity value across all shear rates. Non-Newtonian fluids however have viscosity which changes with the shear rate value. Polymers are non-Newtonian fluids, which generally exhibit a shear thinning behavior (decrease in viscosity with shear rate), across the range of their processing conditions.

Empirical equations have been developed to predict the viscosity of a polymer at a given shear rate. Equation 1 shows the cross-model equation [2] used for predicting viscosity of a polymer.

$$\eta = \frac{\eta_0}{1 + \left(\frac{\eta_0 \dot{\gamma}}{\tau^*}\right)^{1-n}} \quad (1)$$

Where η denotes viscosity, η_0 denotes viscosity of polymer at zero shear rate, $\dot{\gamma}$ is the shear rate, n is the power law index which represents the slope of the viscosity curve at high shear rates (for polymers $n < 1$), τ^* characterizes the shear stress level for the transition region between the Newtonian and the power-law regions.

In addition to shear rate the viscosity of a polymer is also dependent on the temperature to which it is subjected. The WLF model [2] (equation 2) is employed to calculate the temperature dependence of the viscosity of a polymer.

$$\eta_0 = A \exp\left(\frac{-C_1(T - T^*)}{C_2 + (T - T^*)}\right) \quad (2)$$

Where, η_0 denotes viscosity of polymer at zero shear rate, A , C_1 , C_2 , T^* are material parameters, T is the temperature of the polymeric melt.

The polymer used throughout this work is PVC REZ57, whose properties are defined in Table 1. Cross model and WLF model are used for predicting the viscosity of the polymer. For simulating the flow in extrusion die, polyXtrue also needs thermal conductivity k , specific heat C_p and density ρ values of the polymer melt. These values for PVC REZ57 are shown in Table 1.

Table 1 Polymer properties

Parameters	Values
A (Pa.s)	1.94×10^{14}
T^* (K)	3.48×10^2
C_1	3.5×10^1
C_2 (K)	6×10^1
τ^* (Pa)	2.94×10^5
n	1.88×10^{-1}
Thermal conductivity k (W/m.K)	1.7×10^{-1}
Melt density ρ (kg/m ³)	1.46×10^3
Specific heat C_p (J/kg.K)	1.77×10^3

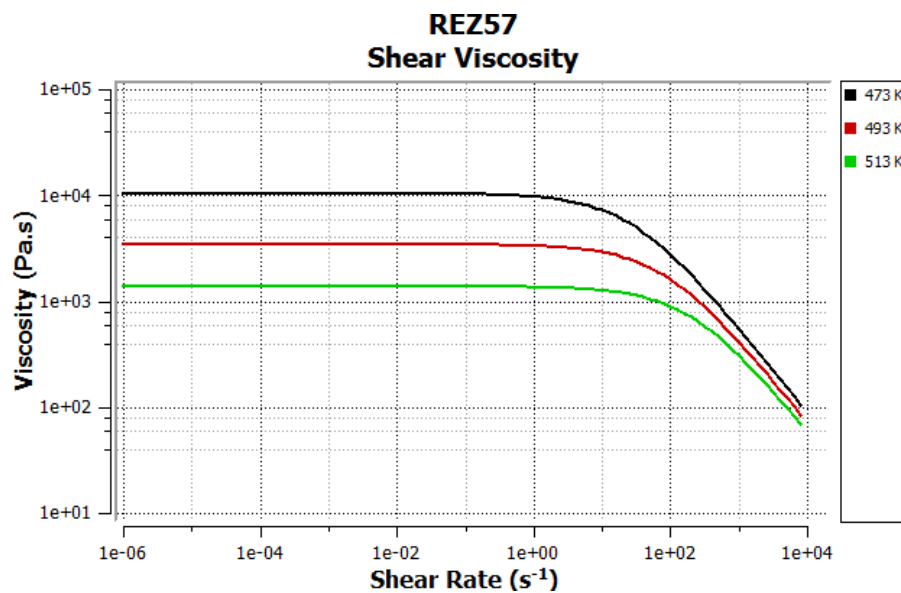

Figure 6 Polymer viscosity graph

4. Die Optimization Methods

PolyXtrue software (version 3.9.00) has been employed throughout this work to run flow simulations in various profile extrusion dies.

Solidworks software (2015 x64 edition) was used to draft CAD models of extrusion dies, and for generation of the modified die geometries during the die optimization process (discussed in detail in the following sections).

4.1 Manual Optimization

In order to optimize an extrusion die, a CAD model of the die is built and polymer flow is simulated across this die. The goal of the optimization procedure is to achieve uniform velocity distribution at the exit face of the die. Figure 7 shows the sequence of steps followed while optimizing the design of a given die.

A 3-D model of the die cavity is first created in any CAD package and saved as a parasolid file which can be processed by polyXtrue. The parasolid file is then imported into polyXtrue, which runs an automatic geometry check. After the model passes the geometry check, the entrance and exit faces of the die are defined.

The next step entails generating a mesh to enable flow analysis. PolyXtrue offers features whereby the mesh density can be easily controlled so as to have a fine mesh in areas which are critical to flow distribution and a coarse mesh elsewhere.

Once the mesh is generated, material properties of the polymer are specified by importing a polyXtrue MAT file, which has the values of all the material properties discussed in Section 3.

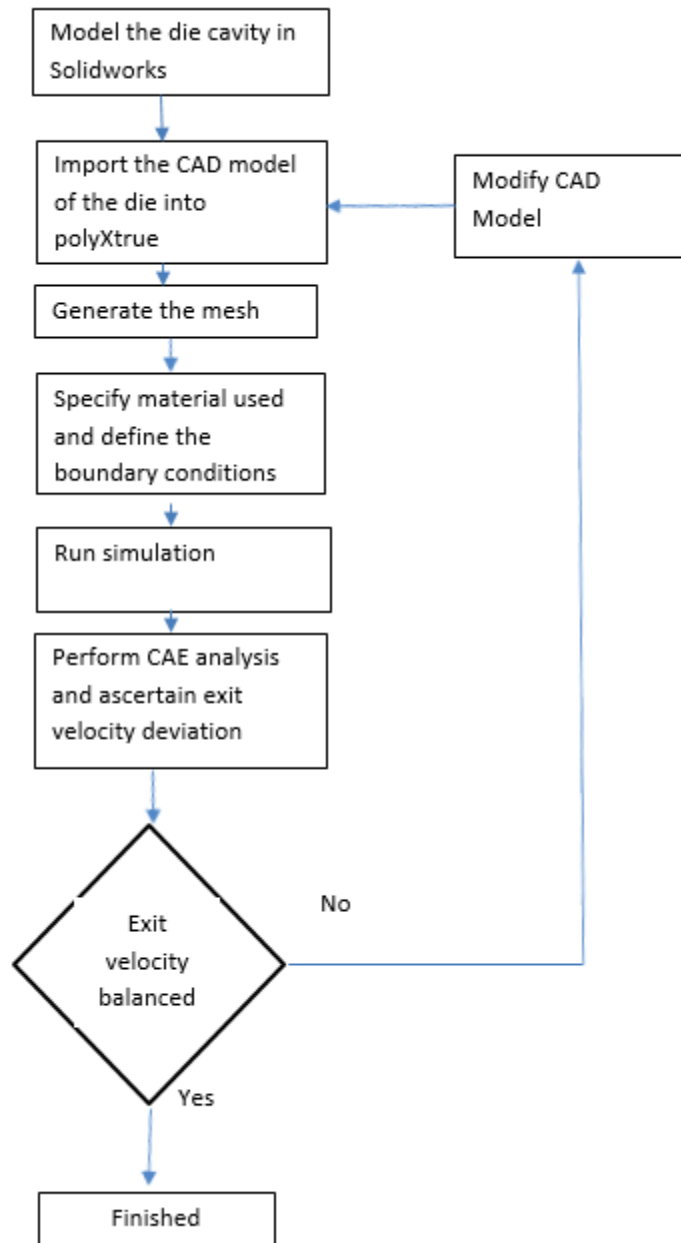

Figure 7 Manual optimization procedure

After selecting the material, the boundary conditions including mass flow rate, temperature of the polymer at entrance and die wall temperature are specified. For co-extrusion dies, in addition to defining the above parameters for additional polymers entering the die, contact lines which indicate the exact location at which a given set of polymers meet, needs to be specified. Also, post-die prediction can be enabled to get an estimate of the change in shape of the extrudate after exiting the die.

After completing the above steps, the die would now be ready for simulation. The simulation time depends on the complexity of the die as well as the density of mesh selected.

Once the simulation is complete the velocity distribution results are studied to understand the reasons for imbalance in velocity at the exit of the die. Changes are then made to the CAD model of the die geometry based on these analysis, and above steps are repeated until a balanced exit velocity profile is obtained.

4.2 Automatic Optimization

Manual optimization of extrusion dies is time consuming and extremely challenging in case of complex profile extrusion dies. To address this concern, an automatic die optimization method is available in polyXtrue. The main advantages of automatic die optimization include, reduced die design development time, improved accuracy and minimum manual intervention in the iterative design improvement cycles.

Automatic die optimization works on the principle of finding the minimum possible objective function value for a given die geometry. Equation 1, describes this objective function.

$$F(x) = \frac{1}{V_a A} \sqrt{\int_A (\vec{v} \cdot \vec{n} - V_a)^2 dA} \quad (1)$$

Where, \vec{v} is the velocity at a point at the die exit, \vec{n} is the unit vector perpendicular to the die exit, A is the area of the exit and the average velocity at the die exit (V_a) is defined as follows,

$$V_a = \frac{1}{A} \int_A (\vec{v} \cdot \vec{n}) dA$$

(The objective function $F(x)$ is referred to as the exit deviation in the remainder of this document. It is used as a measure to quantify the improvement in exit velocity profile of various dies.)

A given die geometry is automatically modified after each flow simulation based on the objective function value, and the simulation is re-run to calculate the new objective function value. This procedure is repeated until the minimum possible objective function value is found within the user defined number of iterations. The steps listed below give a detailed account of how a die geometry is optimized using polyXtrue software.

- After a CAD geometry is created in Solidworks, an initial simulation is run in polyXtrue to identify the critical features which affect the flow distribution in the die.
- Next, these critical features are parameterized in Solidworks using the “Equations, Global Variables and Dimensions” option inside Solidworks (refer Figure 8). Parameterization of a feature entails setting up equations which define the geometry of the feature. These features can then be modified by adjusting the numerical values in the corresponding equations. Also, it is recommended to check the validity of the range for each parameter by rebuilding the geometry for the anticipated maximum and minimum parameter values. Failure to do this might result in the optimization code failing due to inability of Solidworks to create modified die geometries.

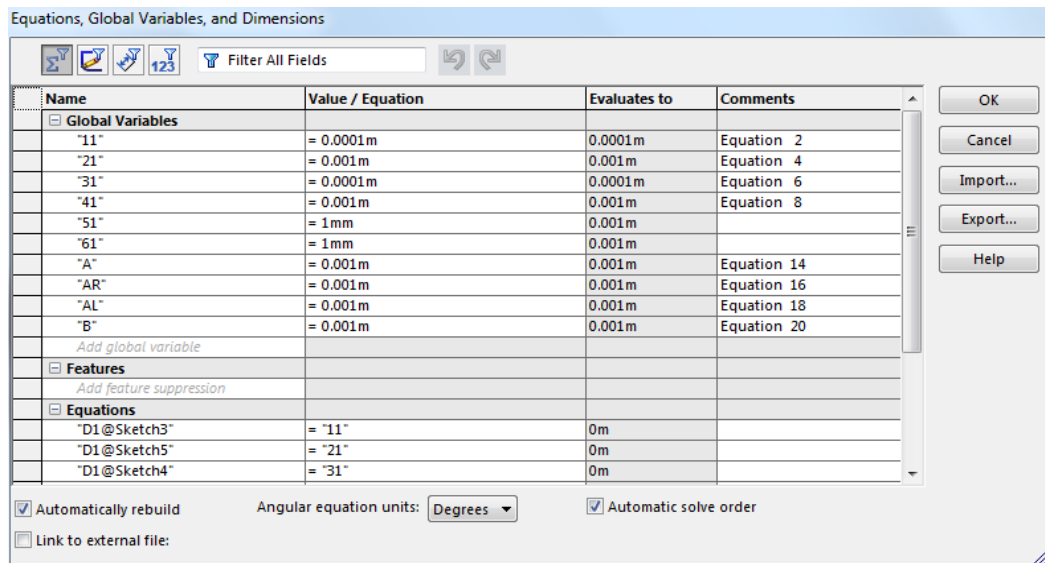

Figure 8 Parameterization of critical features in Solidworks

- The parameterized geometry is then imported into polyXtrue, which is launched as an add-in inside Solidworks. The range of values for the critical features is then defined in polyXtrue (refer Figure 9).
- After defining the parameter ranges, the user can now define the maximum number of iterations which can be run to find the optimized geometry. During the course of these iterations, the software automatically adjusts the geometry after each iteration based on the objective function value, and repeats the flow simulation for the modified geometry. Polyxtrue software uses the Solidworks kernel to make modifications to the die geometry. During the course of simulation iterations the CAD file of the die cavity is automatically updated and exchanged between Solidworks and polyXtrue.

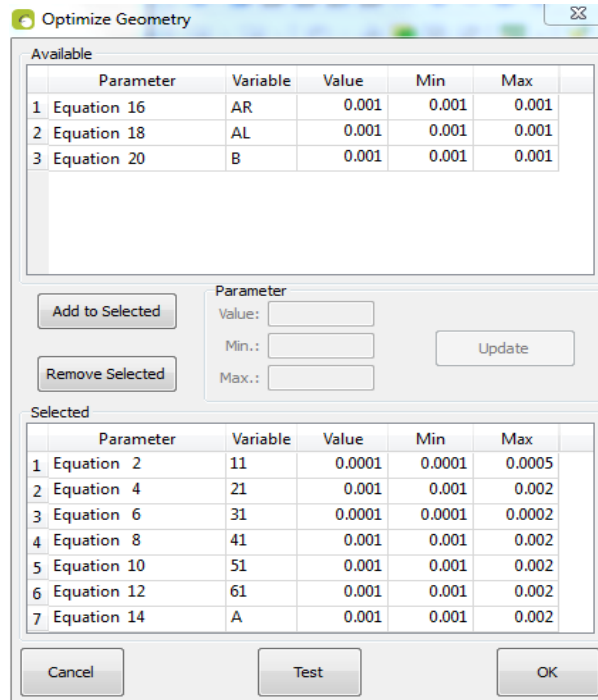

Figure 9 Range definition of critical features in PolyXtrue

- If an optimized die geometry is obtained within the maximum number of iterations specified, the optimization process is stopped at that point and the simulation results for the optimized die are displayed. Otherwise, the optimization process is stopped once the limit for maximum number of flow simulation iterations is reached and the simulation results for the die geometry with the least velocity variation (having the smallest objective function value) is displayed.

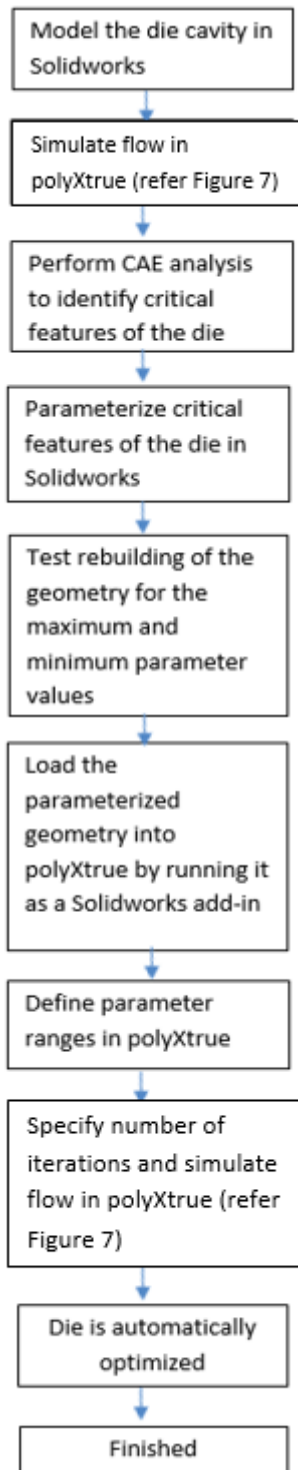

Figure 10 Automatic optimization procedure

5. Design Methodologies

The design process for extrusion dies has transformed over the years from an experimental trial and error based approach, to one which relies on computer based flow simulations to design and fine tune the die design. However, the design process is still considered to be more of an art than science [9], since it is heavily dependent on the experience of the designer.

Plastic Flow LLC, has been successful in helping its customers improve their extrusion die design for over the last 13 years. After studying various extrusion dies which have been optimized by Plastic Flow, it was found that there were certain common design features which have proven to be critical in obtaining a balanced die (die having uniform velocity at exit). There has been very little mention of these features in previous literature, and hence there is a need to examine these features more closely and develop a document which describes them.

The following sections describe various extrusion dies, each having a unique feature. Flow was simulated through each of these die, before and after the insertion of the feature under discussion, and the resulting velocity plots are discussed.

Each section corresponds to a unique feature, and hence can be considered as a design guideline which can be implemented while designing the die. These design features can be implemented to design new extrusion dies as well as improve the exit velocity distribution in existing extrusion dies.

5.1 Design Feature 1: Land length modification

One of the widely used techniques to balance the flow at the exit face of the extrusion die is to change the land length locally. In this technique, land length is increased for areas having a high a flow concentration whereas land length is decreased for areas having a low flow concentration. The following sections discuss the different design features which can be implemented to modify the land length locally.

5.1.1 Scaled-Up preland

Figure 11 shows the required dimensions of the extrudate, and Figure 12 shows a CAD model of the die developed to produce this extrudate.

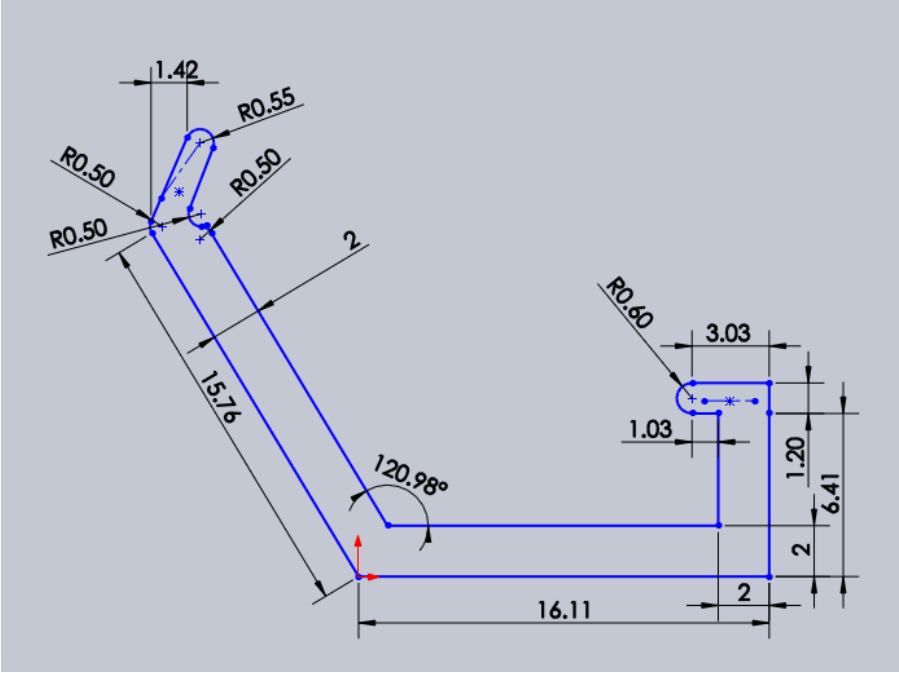

Figure 11 Extrudate dimensions (in mm)

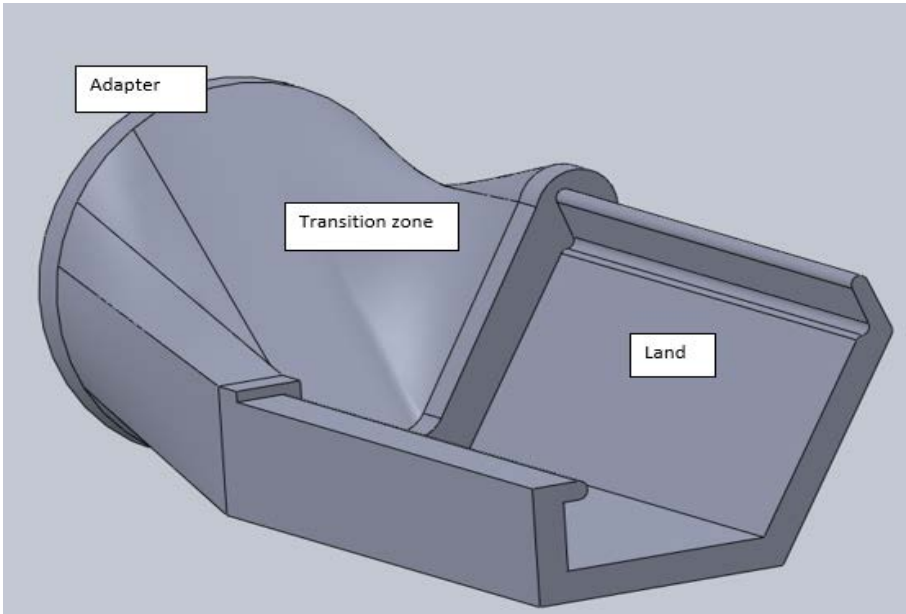
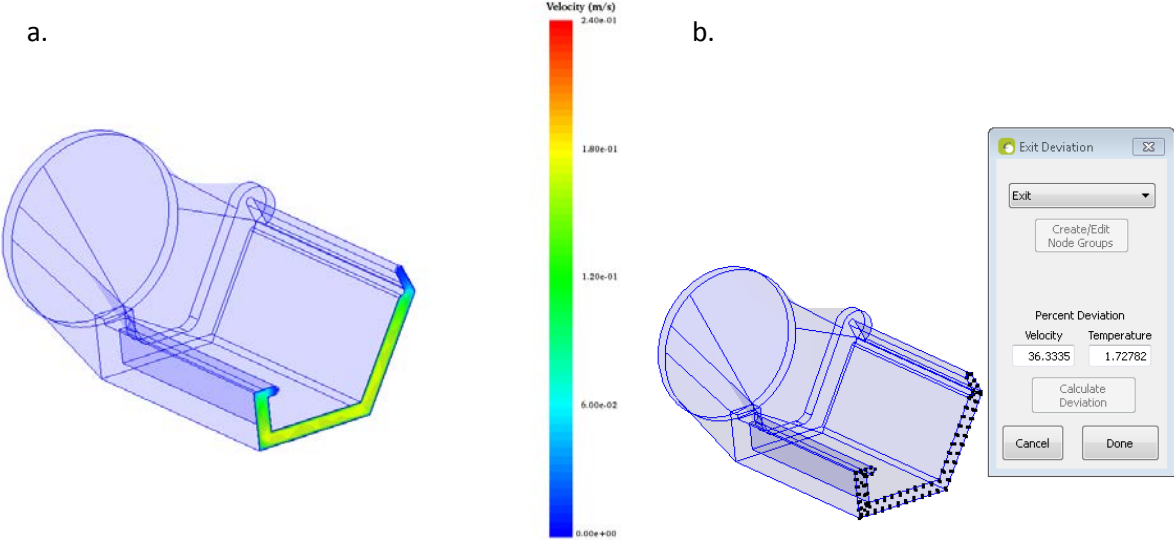

Figure 12 3-D model of initial extrusion die

As can be seen from the shape of required extrudate, there are sections on either ends of the profile which have a considerably lower thickness as compared to other sections of the die. This is expected to cause a slower flow in the area with less thickness to and hence result in an imbalanced exit velocity profile. Flow simulation was run to validate this assumptions. Table 2 shows the boundary conditions while running the flow simulations. Figure 13 show the flow simulation results.

Table 2 Boundary conditions

Parameter	Value
Mesh Size	1.5 mm
Mass flow rate	50 kg/hr.
Inlet temperature	455 K
Primary wall temperature	465 K
Material used	PVC REZ57



c

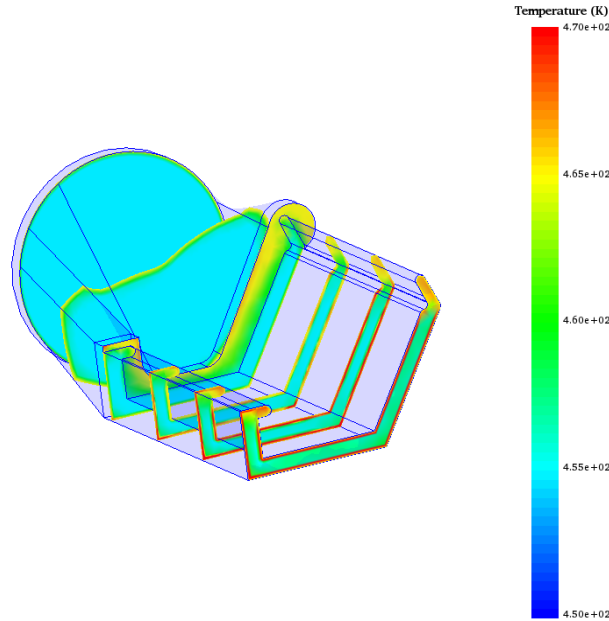

Figure 13 (a) Velocity plot (b) Exit deviation (c) Temperature plot in the initial die

The mesh size for different geometries in this report is selected based on the size of the die and the intricacy of the extrudate shape desired.

As can be seen from Figure 13a, there is a very small amount of flow through the thin sections of the profile, whereas flow through the remaining sections of the profile is balanced.

To improve the flow in these thin sections, it is suggested to scale up the corresponding areas upstream the exit face to increase flow in these sections. Also, flow separators have been added to prevent the flow from the scaled-up sections being diverted back to thicker regions of the die. Figure 14 shows the CAD geometry of the modified die.

Manual design modification iterations were performed, to optimize the size of the scaled up features and the length of the flow separators. The length of flow separators was kept to a minimum to improve the strength of the weld line (line at which polymer from the two flow channels merge after the flow separator), and hence, manufacture a high strength part.

Figure 15 shows the flow simulation results for the modified die.

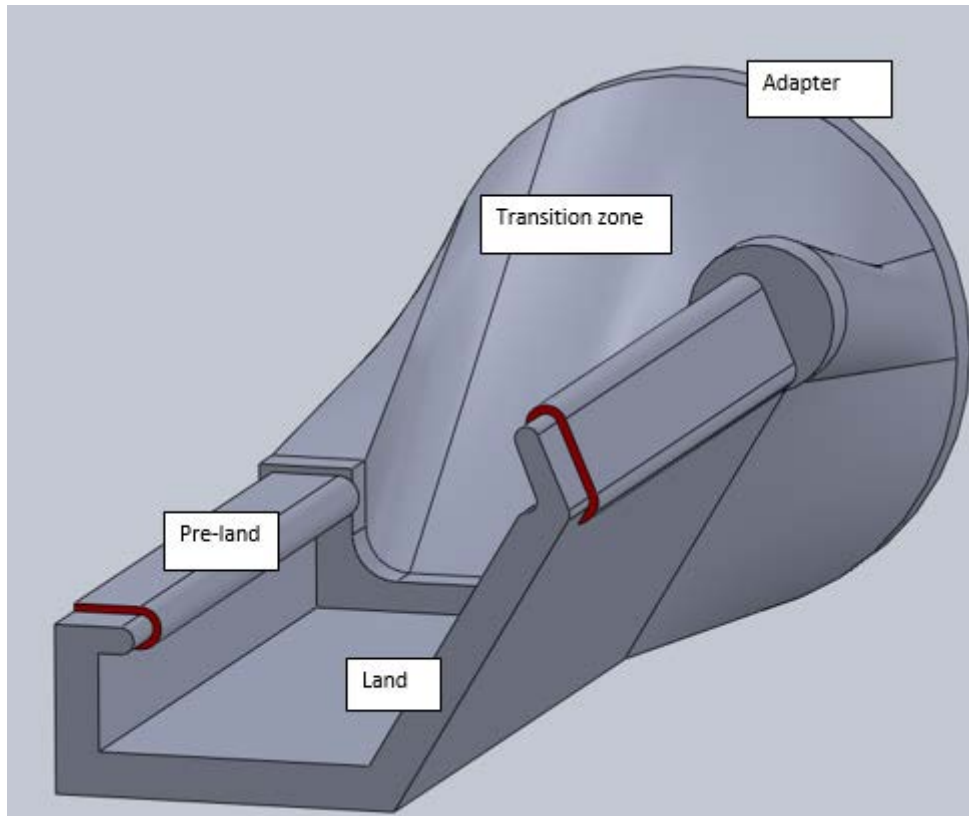
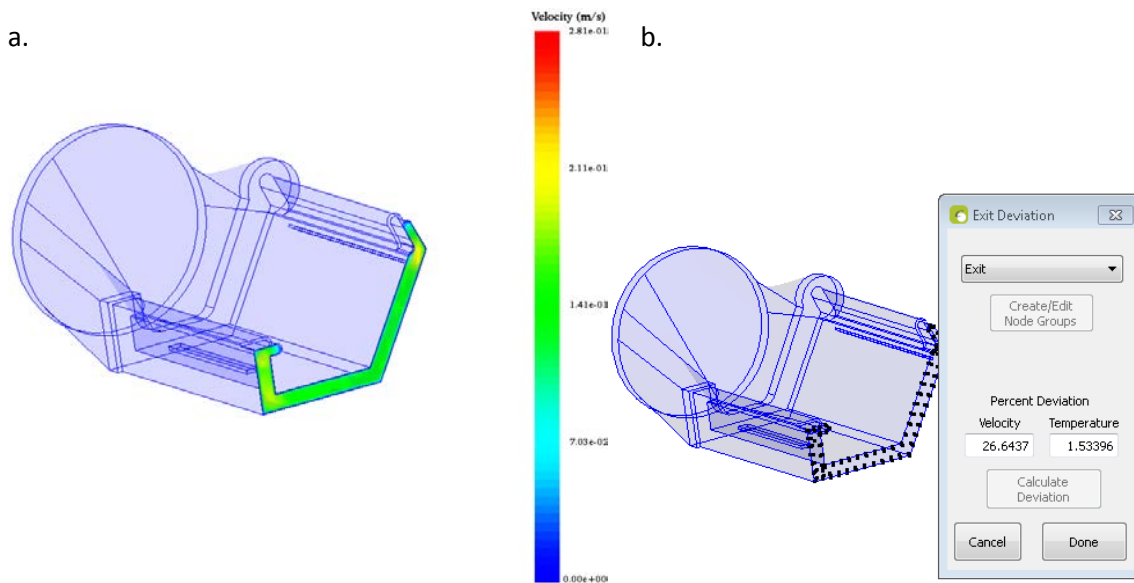

Figure 14 CAD geometry of modified die



C

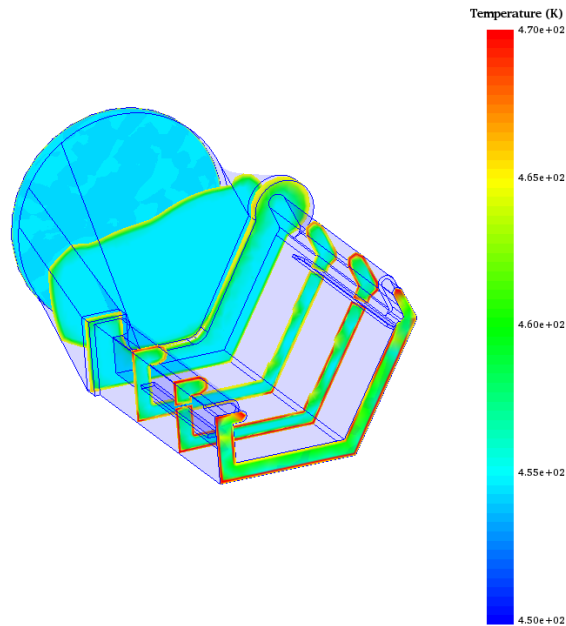

Figure 15 (a) Velocity plot (b) Exit deviation (c) Temperature plot in the final die

As can be seen from the flow simulations in the modified die, the velocity profile at the exit is more uniform since there is an increased flow in thin sections due to the larger cross-section of the scaled-up pre-land. This has been quantified by the exit deviation value has decreased from 36.3 (original die) to 26.6 (modified die). Hence, the application of using scaled-up features upstream to improve flow in the thin sections of the profile has been validated.

Also, Figures 13 (c) and 15 (c) show temperature profile of the polymer flowing through the initial die and final die respectively. Polyxtrue software takes into account the variation in viscosity of the polymer caused by the change in temperature. This ensures the accuracy of the flow simulation results for different dies.

5.1.2 Approach angle adjustment

Figure 16 shows the required dimensions of the extrudate, and Figure 17 shows a CAD model of the die developed to produce this extrudate.

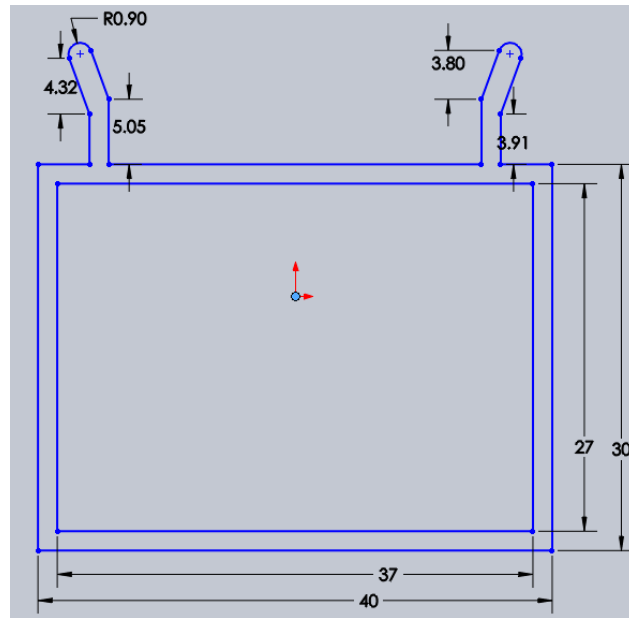

Figure 16 Extrudate dimensions (in mm)

As can be seen from the extrudate shape, the top sections of the projections have higher thickness compared to other sections of the die. This would lead to an increased flow in these sections. Flow simulation was run to validate this assumption. Table 3 shows the boundary conditions while running the flow simulations. Figure 18 (a), (b) show the results from the flow simulation.

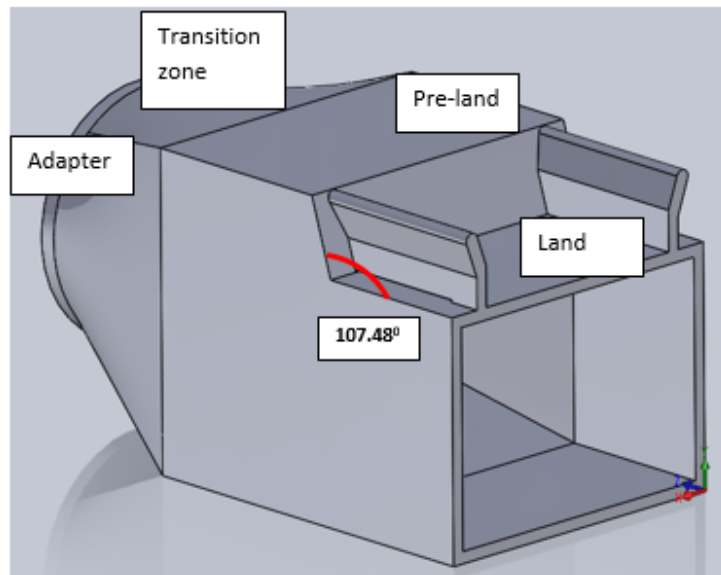

Figure 17 3-D model of initial extrusion die

Table 3 Boundary conditions

Parameter	Value
Mesh Size	2 mm
Mass flow rate	60 kg/hr.
Inlet temperature	465 K
Primary wall temperature	465 K
Material used	PVC REZ57

As can be seen from Figure 18 a, the flow is concentrated in the two projections on the top side of the die. By studying the profile across various cross-sections of the die it was revealed that a small value of the approach angle (shown in Figure 17) might be responsible for this effect.

To balance the flow it was proposed to increase the approach angle value, since this would increase the projection flow channel length and hence cause the flow to even out over the entire projection area. A modified die with an increased approach angle value is shown in Figure 19.

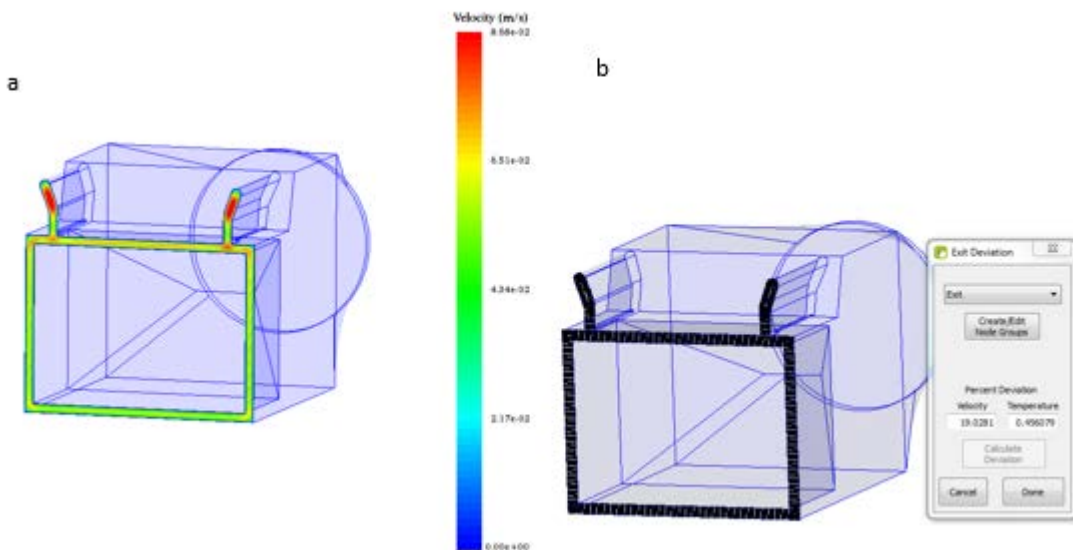

Figure 18 (a) Velocity plot (b) Exit deviation measured in the initial die

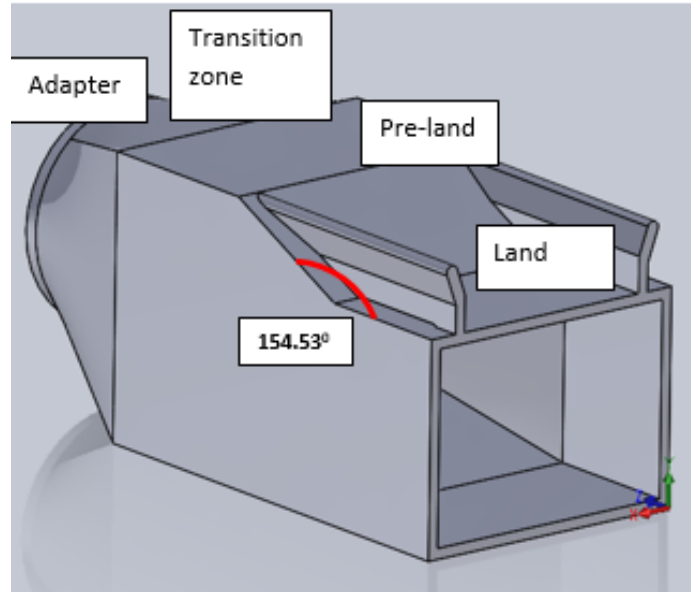

Figure 19 CAD geometry of modified die

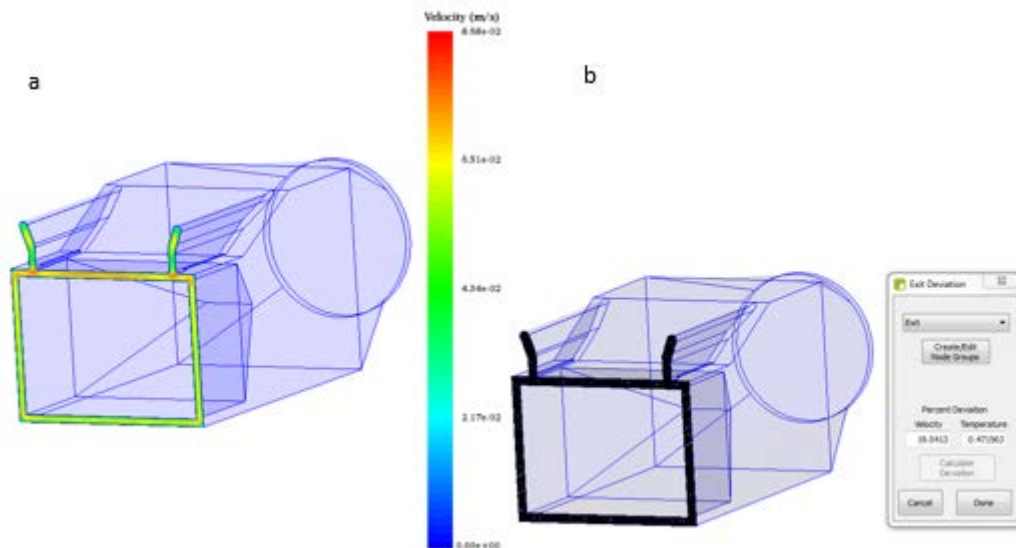

Figure 20 (a) Velocity plot (b) Exit deviation measured in the final die

As can be seen from Figure 20a, the flow concentration is reduced in top portions of projecting sections of the die. However, the exit deviation value has almost remained constant with values of 19.02 (original die) and 19.04 (modified die). This constancy of the exit deviation value might be attributed to a slight increase in flow in the top face of the die, which is caused by an increase

in the approach angle value. Hence the local land length is modified by changing the approach angle value which plays a critical role in evenly distributing the flow across various sections of the die.

5.1.3 Channel length adjustment

Figure 21 shows the required dimensions of the extrudate with different wall thicknesses, and Figure 22 shows a CAD model of the die developed to produce this extrudate. As can be seen from the shape of the extrudate, two side walls have a varying thickness across their length with the lower half being thicker than the top half. Is expected to result in the flow being concentrated in the bottom section of the die. Flow simulation was run to validate this assumption.

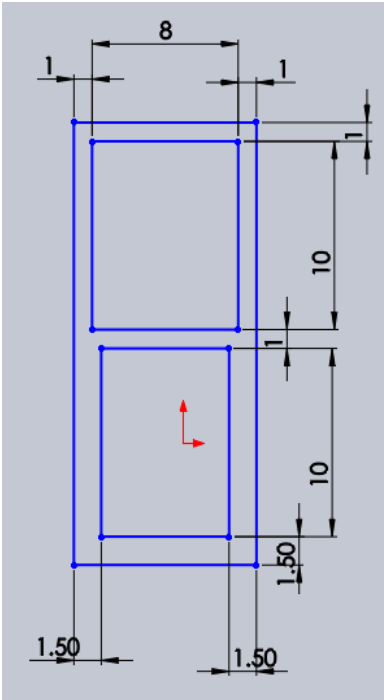

Figure 21 Extrudate dimensions (in mm)

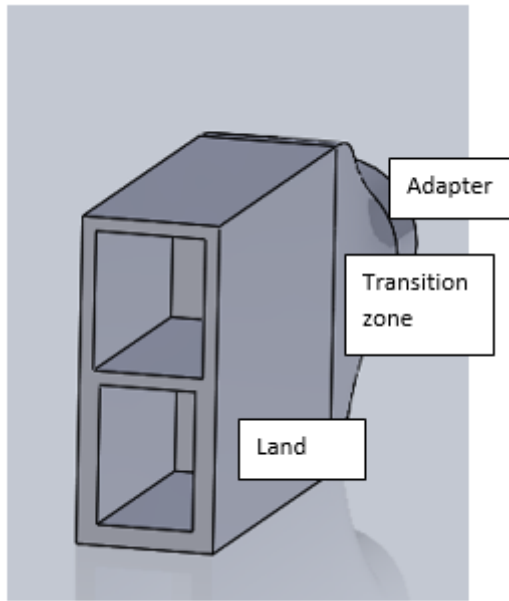

Figure 22 3-D model of initial extrusion die

Table 4 shows the boundary conditions employed while running the flow simulations. Figure 23 (a), (b) show the flow simulation results.

Table 4 Boundary conditions

Parameter	Value
Mesh Size	1 mm
Mass flow rate	60 kg/hr.
Inlet temperature	465 K
Primary wall temperature	465 K
Material required	PVC REZ57

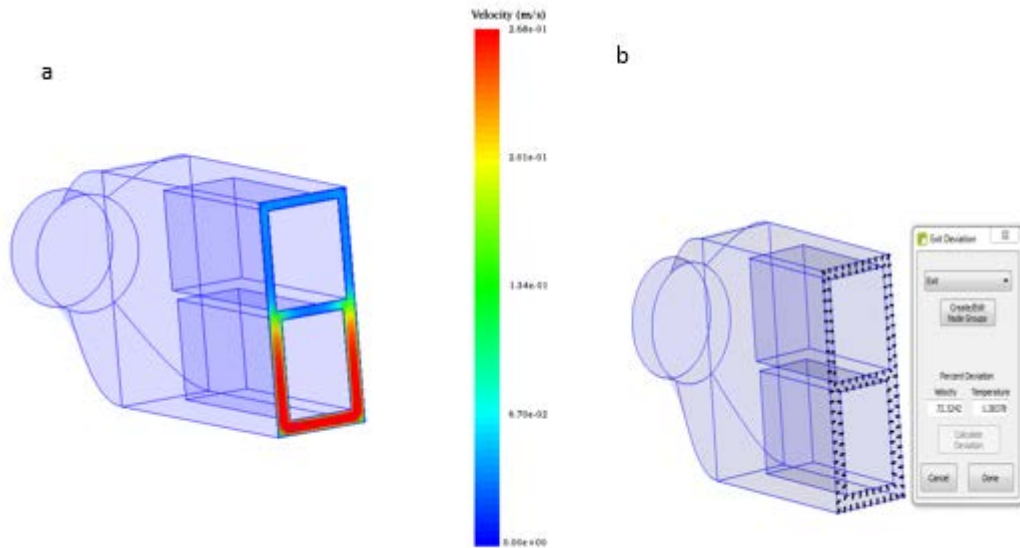

Figure 23 (a) Velocity plot (b) Exit deviation in the initial die

As can be seen from Figure 23 (a), due to the higher wall thickness in the bottom half of the die the flow is concentrated in the lower region. To balance this die, the restriction to flow has to be decreased in the top half, which can be achieved by reducing the land length in the top section. A modified die with reduced land length in the top section is shown in Figure 24, and the flow simulation results across this die are shown in Figure 25 (a), (b).

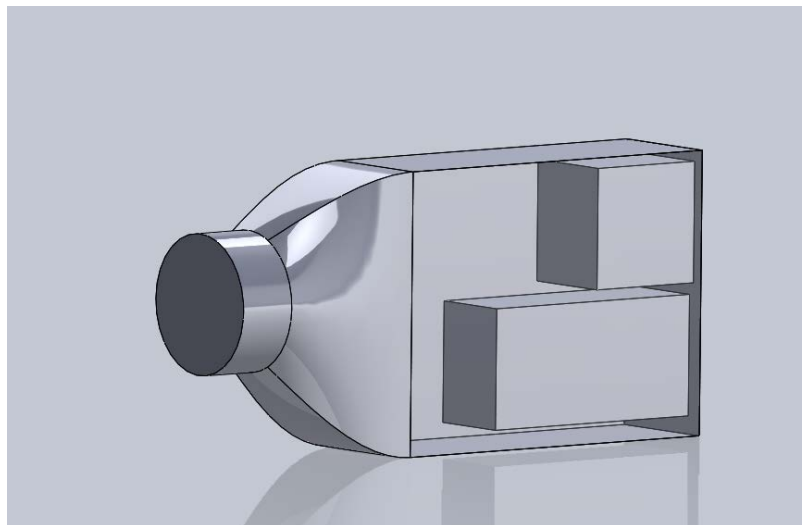

Figure 24 3-D model of modified extrusion die (side face made transparent to show variation in flow channel geometry)

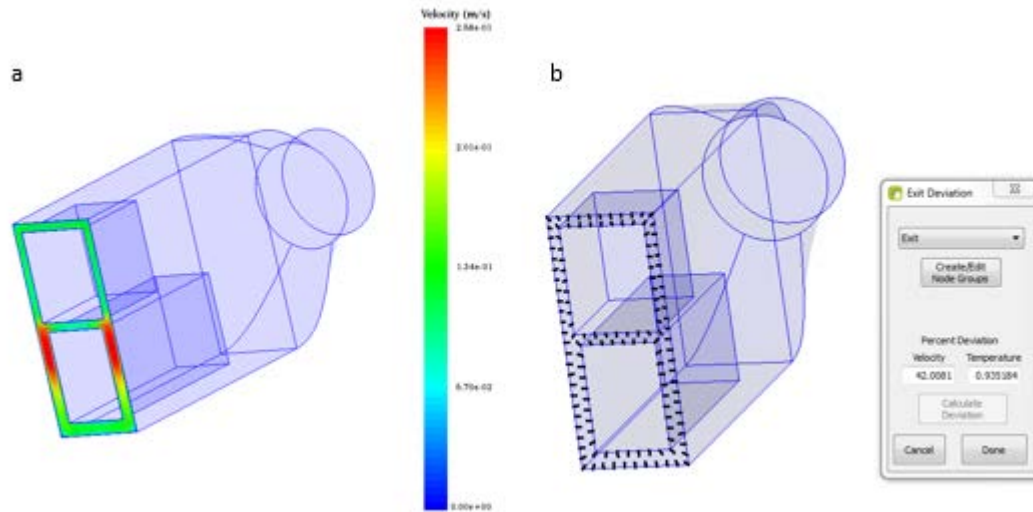

Figure 25 (a) Velocity plot (b) Exit deviation in the final die

As can be seen from the flow simulation results, the flow is more evenly distributed in the top and bottom half's of the die. The exit deviation value has been reduced from 72.32 (original die) to 42.00 (modified die). However, there is still a high concentration of flow in the middle sections of the die, which is addressed in the section 5.2.2.

Additionally it is noted that similar balancing technique may be employed if the top channel is thicker than the bottom channel.

5.1.4 Isolated channel 1

Figure 26 shows the required dimensions of the extrudate with a thicker projection at the bottom left corner, and Figure 27 shows a CAD model of the die developed to produce this extrudate.

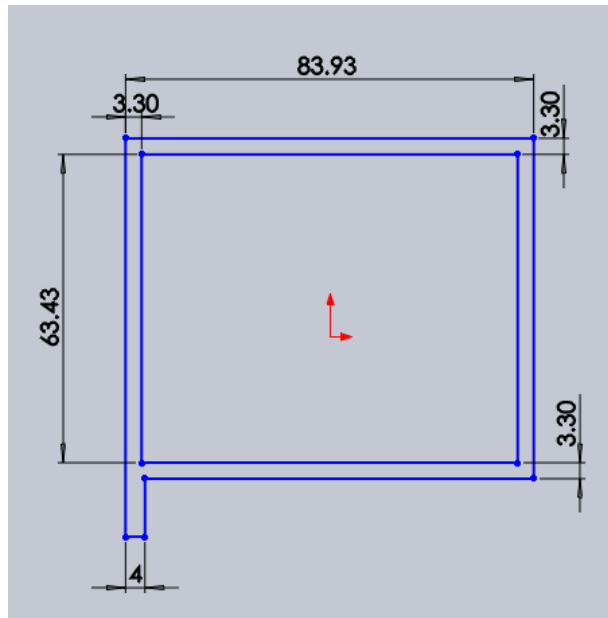

Figure 26 Extrudate dimensions (in mm)

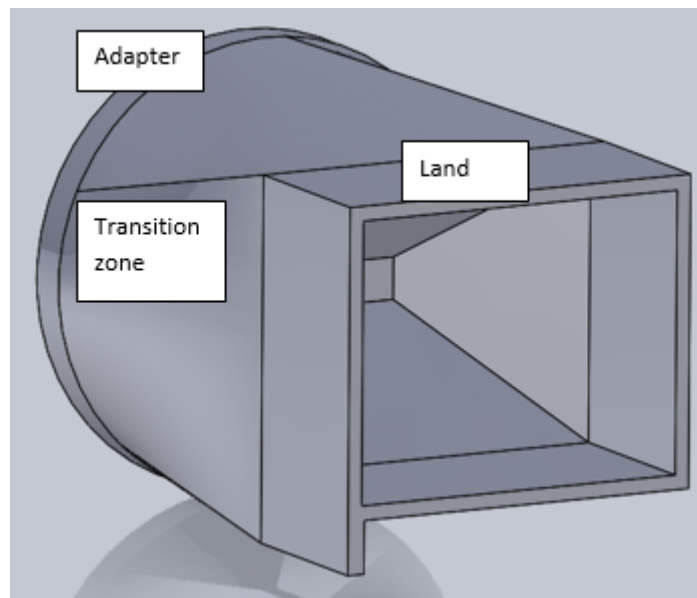

Figure 27 CAD model of initial extrusion die

As can be seen from the shape of the extrudate, the side wall has a bottom projection which is thicker than other sections of the die. This would result in a higher flow in this region of the die. Flow simulation was run to validate this assumption. Table 5 shows the boundary conditions while running the flow simulations. Figure 28 (a), (b) show the flow simulation results.

Table 5 Boundary conditions

Parameter	Value
Mesh Size	4 mm
Mass flow rate	50 kg/hr.
Inlet temperature	455 K
Primary wall temperature	465 K
Material used	PVC REZ57

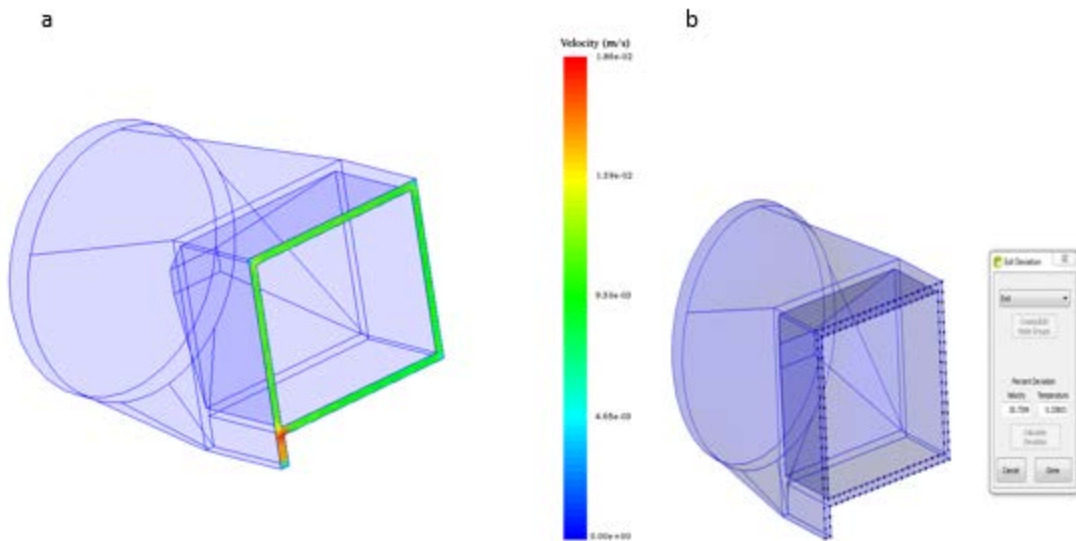

Figure 28(a) Velocity plot (b) Exit deviation measured in the initial die

As can be seen from Figure 28 (a), flow is concentrated at the bottom left corner of the profile, which has a slightly greater thickness than the other sections of the profile. To address this imbalance, a modified die, having a separate flow channel introduced in the land region, is shown in Figure 29. The flow simulation results across this die are shown in Figure 30 (a), (b).

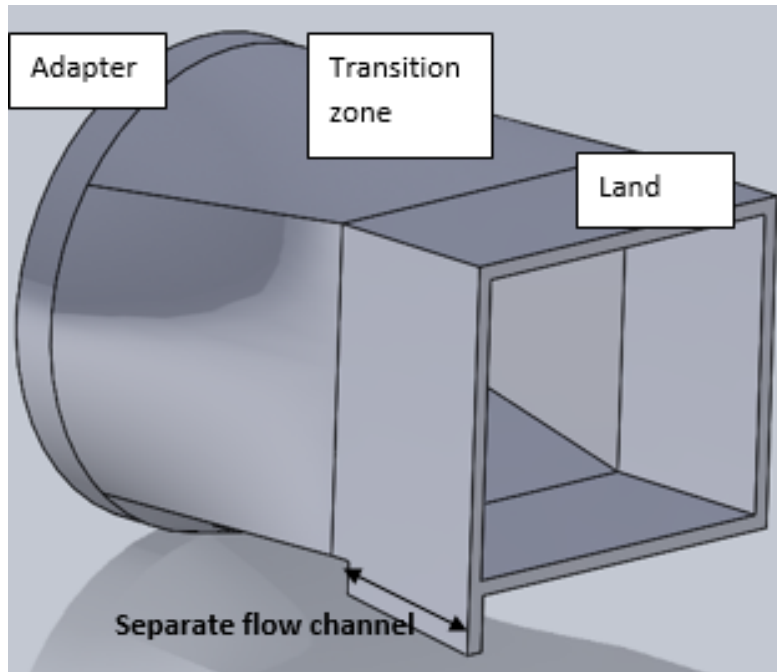

Figure 29 3-D model of modified extrusion die

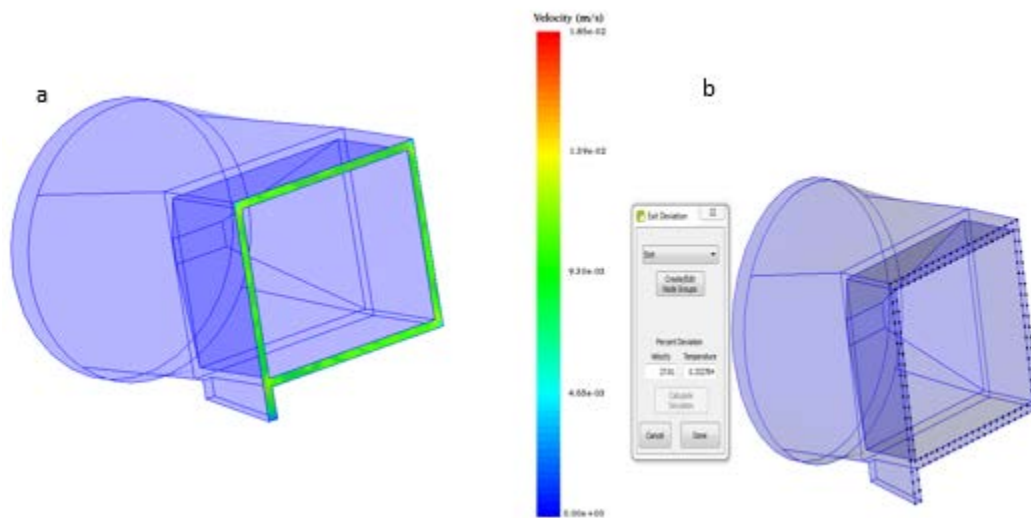

Figure 30 (a) Velocity plot (b) Exit deviation measured in the final die

As can be seen from the simulation results, the flow is now balanced in the die. The independent flow channel for the thicker projection is not fed directly from the extruder and hence there is no flow build up in the bottom projection. The length of this flow channel needs to be optimized to attain a balanced velocity profile at the exit face.

This improvement in exit velocity distribution is quantified by a change in the exit deviation value which has decreased from 30.72 (original die) to 27.81 (modified die).

Hence, it is advised to divert flow into the thicker projecting sections, by introducing flow channels in the land region, rather than having a continuous flow from the adapter. This technique reduces the cross-flow and hence provides a more uniform exit velocity profile.

5.1.5 Isolated channel 2

Figure 31 shows the required dimensions of an extrudate, and Figure 32 shows a CAD model of the die developed to produce this extrudate.

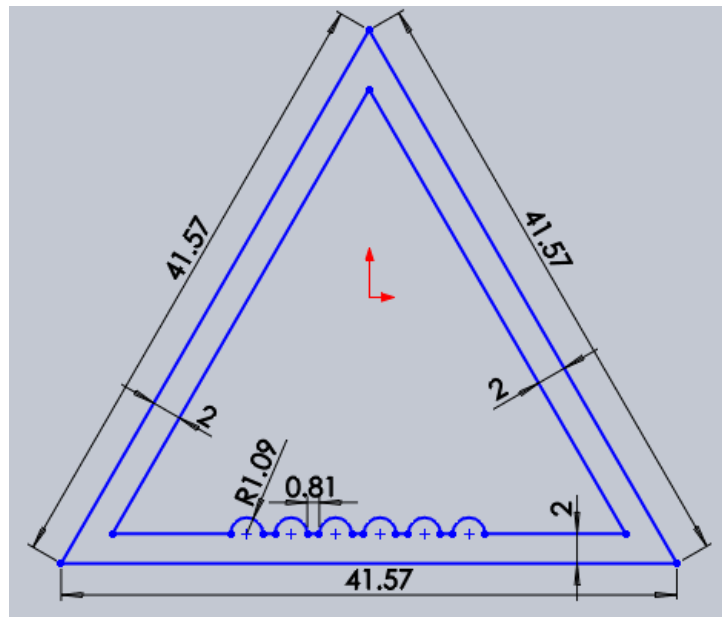

Figure 31 Extrudate dimensions (in mm)

As can be seen from the extrudate dimensions, there are relatively small projections on the bottom wall which increases the effective thickness of this wall. It is generally difficult to obtain a uniform velocity distribution through such features. Flow simulation was carried out to study the velocity distribution in this die.

Table 6 shows the boundary conditions while running the flow simulations. Figure 33 (a), (b) show the flow simulation results.

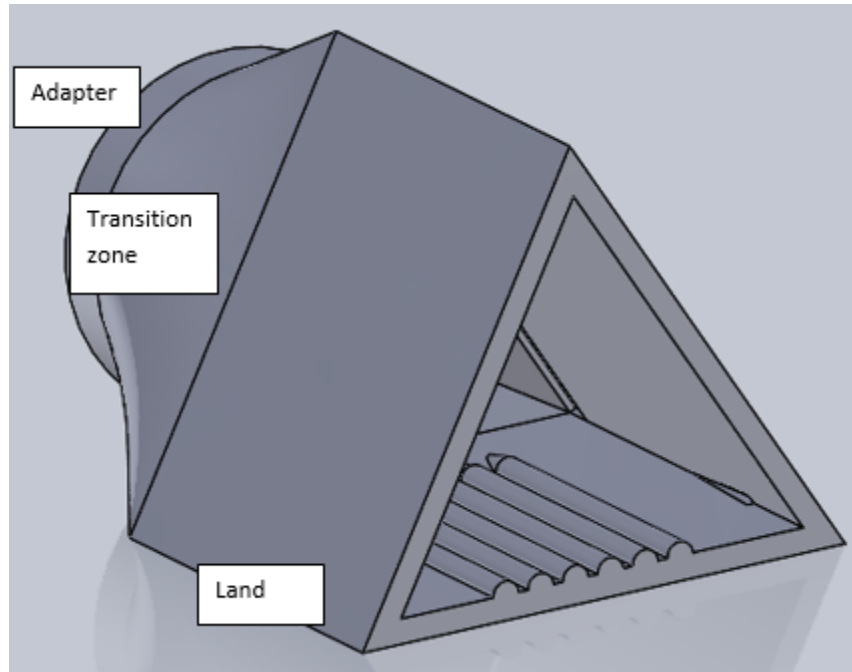

Figure 32 CAD model of initial extrusion die

Table 6 Boundary Conditions

Parameter	Value
Mesh Size	2 mm
Mass flow rate	60 kg/hr.
Inlet temperature	465 K
Primary wall temperature	465 K
Material used	PVC REZ57

As can be seen from the Figure 33(a), there is a high concentration of flow just below the projections on the bottom face. This can be attributed to the larger effective thickness of the flow channel due to the semi-circular projection in this area. This causes buildup of flow in the adjoining regions of the projections and leads to an imbalanced exit velocity profile.

To address this imbalance in exit velocity it is proposed to reduce the flow channel length of the projections in the land region of the die. This strategy is unique in that, land of a die is generally

referred to as a region that has the same cross-section as that of the required extrudate. In this case the extrudate cross-section matches the land cross-section only for final portion of the land length.

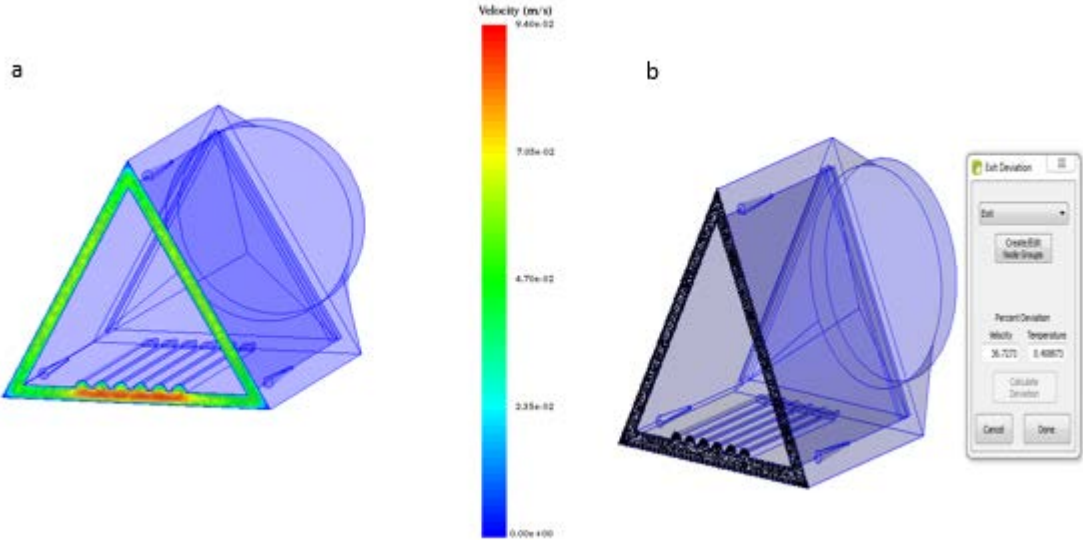

Figure 33(a) Velocity plot (b) Exit deviation measured in the initial die

Figure 34 shows the CAD model of the modified die and Figure 35 (a), (b) shows the flow simulation results across this die.

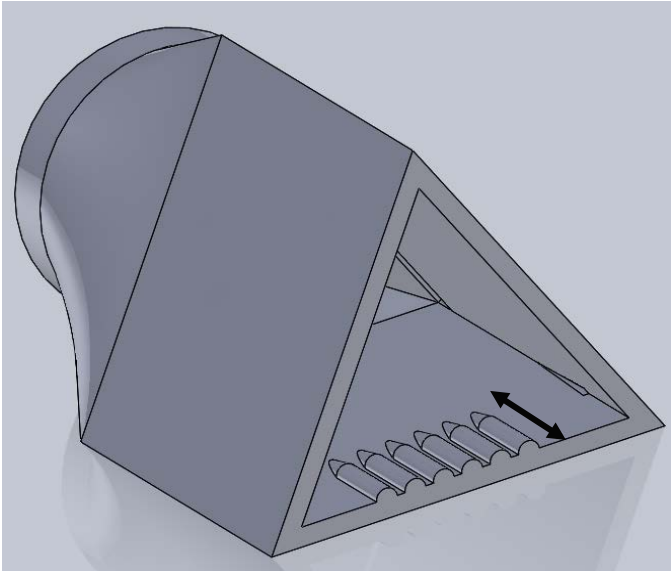

Figure 34 Modified die (reduced projection length)

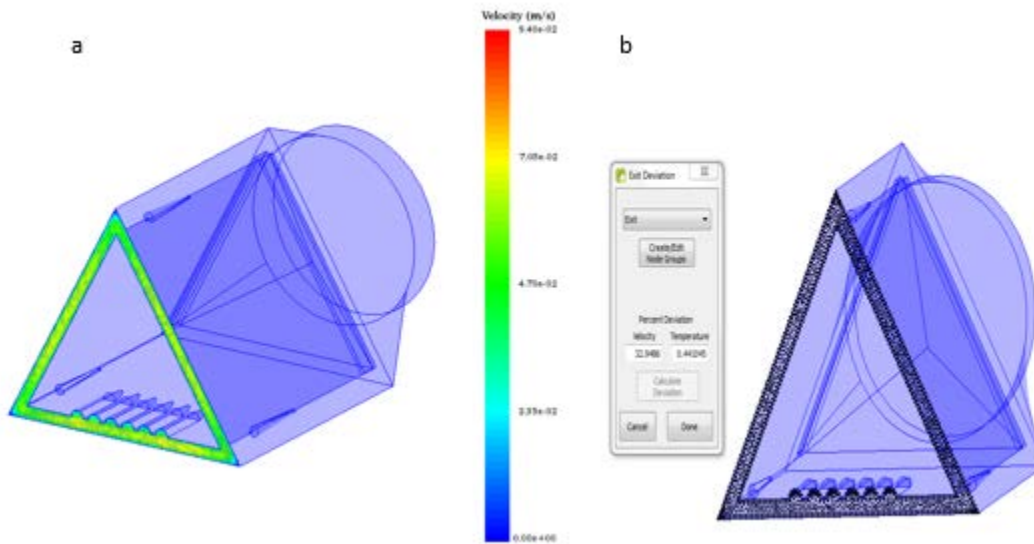

Figure 35(a) Velocity plot (b) Exit deviation measured in the final die

As can be seen from the simulation results (Figure 35(a)), the flow is now balanced in the die. The reduction in projection channel length causes the flow to move into projections in the latter part of the land region, and it is prevented from exiting these channels due to the relatively short length of the channels. The reduction in exit deviation value from 36.72 (original die) to 32.94 (modified die) quantifies this improvement. This design guideline is applicable when fine features (features having a small thickness as compared to wall thickness) are to be formed on the surface of the extrudate.

5.2 Other Unique Design Features

The following sections discuss other unique features employed to balance the flow at the extrusion die exit.

5.2.1 Design Feature 2: Slits

Figure 36 shows the dimensions of the desired shape, and Figure 37 shows the CAD model of the extrusion die developed to produce this shape.

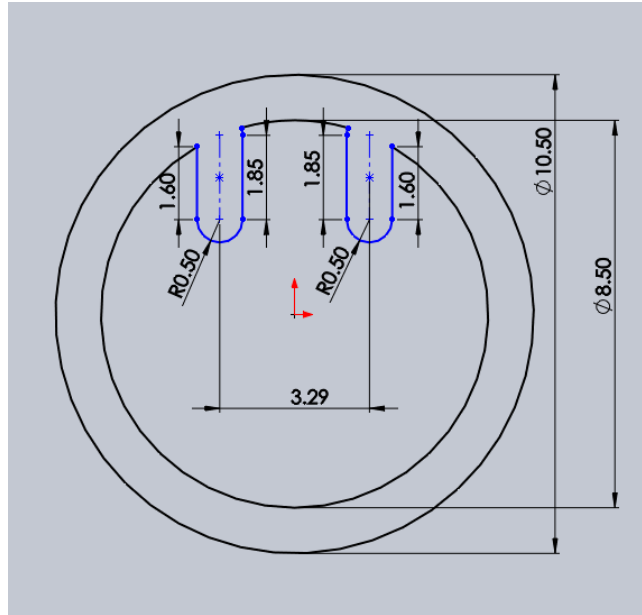

Figure 36 Extrudate dimensions (in mm)

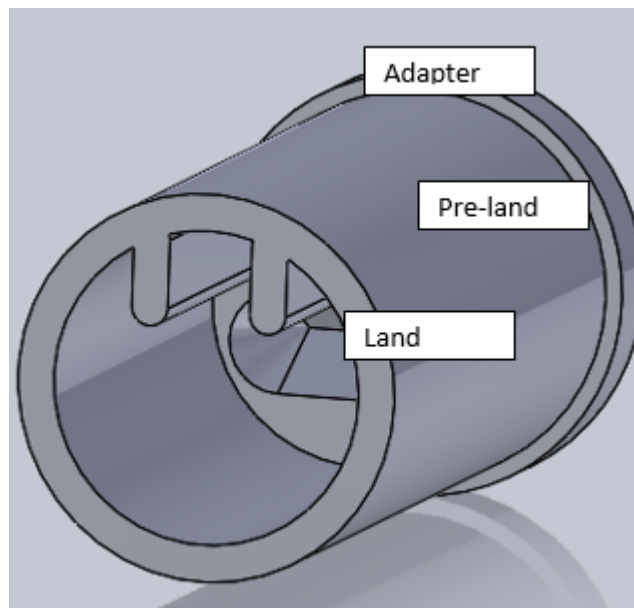

Figure 37 3-D model of initial extrusion die

With the thickness of the two vertical tabs being same as the same as the thickness of the circular pipe (1mm), the effective flow resistance is smaller at the T-junction between the pipe and the vertical tabs. This would lead to a concentration of flow in the areas having higher thickness, and hence cause a velocity imbalance at the die exit.

Flow simulation was simulated in this die geometry to validate this assumption.

Table 7 shows the boundary conditions while running the flow simulations. Figure 38 (a), (b), (c) show the flow simulation results.

Table 7 Boundary conditions

Parameter	Value
Mesh Size	0.7 mm
Mass flow rate	50 kg/hr.
Inlet temperature	455 K
Primary wall temperature	465 K
Material used	PVC REZ57

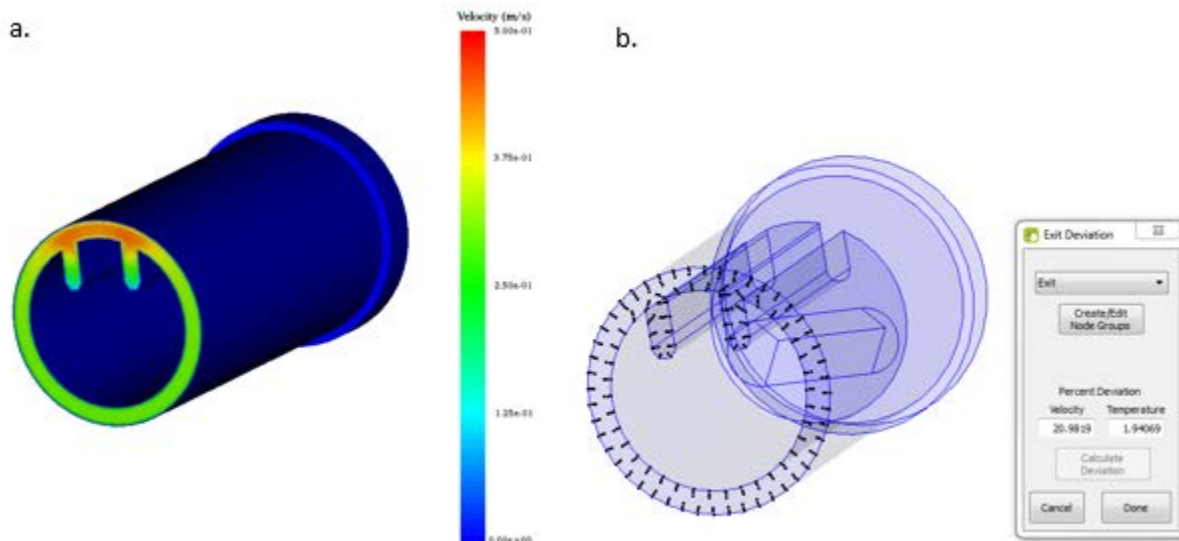

C.

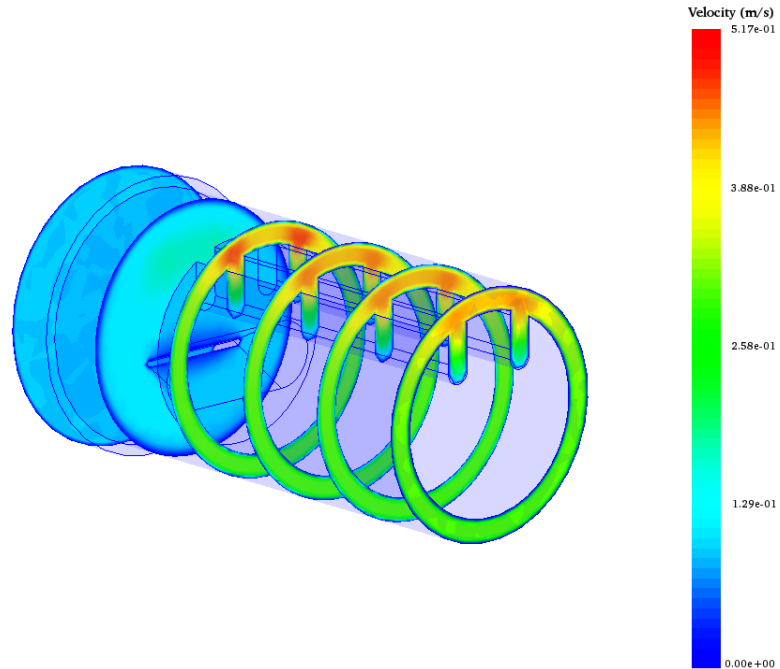

Figure 38 (a) velocity plot (b) exit deviation (c) velocity profile cut sections in the initial die

As can be seen from the simulation results, flow tends to be concentrated in the top quarter of the profile as expected (Figure 38 a).

To achieve uniform velocity distribution at the exit face, a modified die as shown in Figure 39 was proposed.

The modified die has “slits” (slots projecting into the flow channel), which have been added in the pre-land section of the die. These slits increase the resistance of flow in the region with two T-junctions, and hence moving the flow away from this region resulting in a more balanced exit velocity profile.

To obtain a minimum value of exit velocity deviation, manual design modification iterations were performed to optimize the length, width and depth of the two slits.

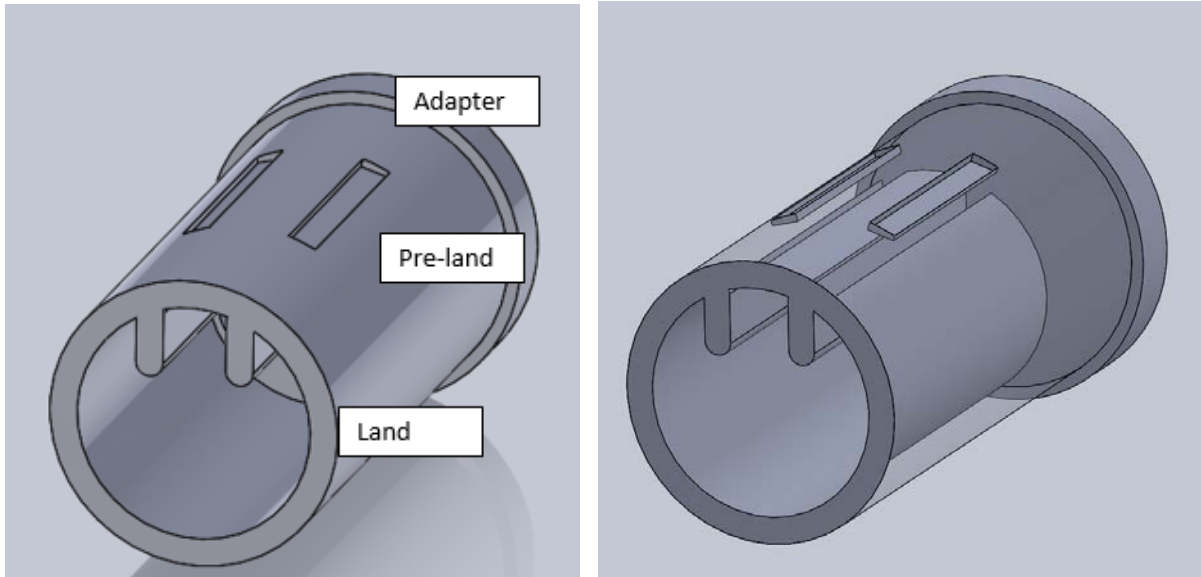

Figure 39 (a) 3-D model of modified extrusion die (b) 3-D model of modified extrusion die
outside face transparent

Figure 40 (a), (b), (c) shows the flow simulation results through the optimized die. As can be seen from the modified die flow simulations, the velocity profile at the exit is more uniform, and the exit deviation value has been decreased from 20.98 (original) to 17.0 (modified) and hence the advantage of using slits for moving the fluid away from the high flow concentration areas has been proven.

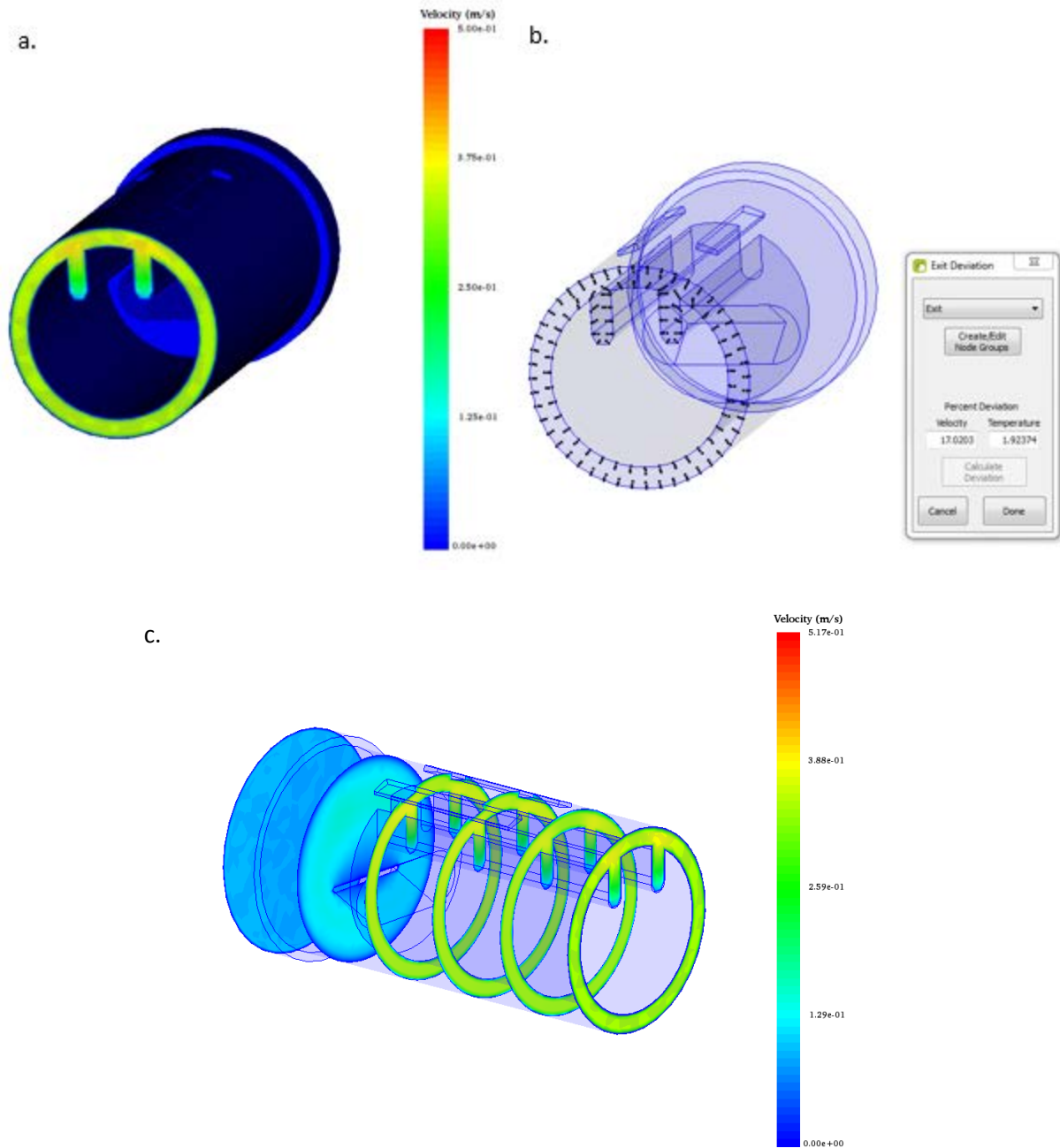

Figure 40 (a) Velocity plot (b) exit deviation measured (c) velocity profile cut sections in the final die

5.2.2 Design Feature 3: Dams

As can be seen from the flow simulation results in Figure 25(a), there is a high concentration of flow in the middle sections, which is caused by a cross flow from top section to bottom section.

This cross flow is caused due to an increased resistance to the flow in the top section, as the flow gets closer to the exit of the die.

To overcome this limitation, it is proposed to introduce a “dam” (walls restricting the cross-flow) into the die channel. A CAD model of the modified die with a dam between the top and bottom section is shown in Figure 41 and the flow simulation results are shown in Figure 42 (a), (b).

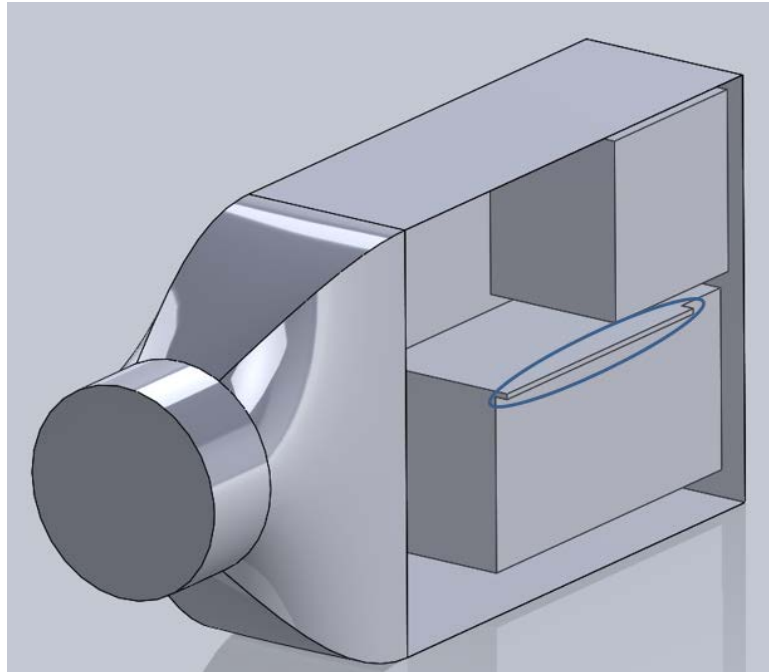

Figure 41 3-D model of modified extrusion die (side face made transparent to show the “dam”)

It should be noted that the concept of “dam” is different from that of “flow separator”. A dam is a section extended in to the flow channel, whereas a flow separator is used to completely isolate two adjacent channels.

Use of flow separators is not recommended close to the exit, as they lead to formation of weld lines in the final extrudate, thereby decreasing its mechanical strength. Dams on the other hand only restrict cross-flow and hence result in a product having better strength.

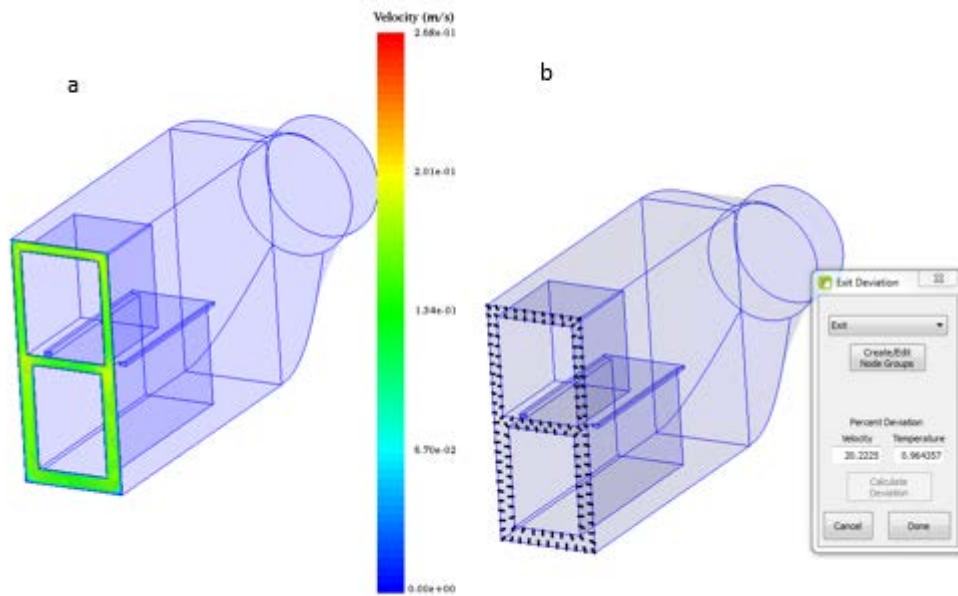

Figure 42 (a) Velocity plot (b) Exit deviation measured in the final die

As can be seen from the simulation results, with the use of dams on two sides of the flow channel, the flow is now balanced in the die. The exit deviation value has decreased from 42.00 (original die) to 20.22 (modified die with dams). Hence the employment of “dams” to restrict cross-flow has been validated.

5.2.3 Design Feature 4: Pre-land flow separators

Figure 43 shows the required dimensions of the extrudate with thinner bottom wall, and Figure 44 shows a CAD model of the die developed to produce this extrudate shape.

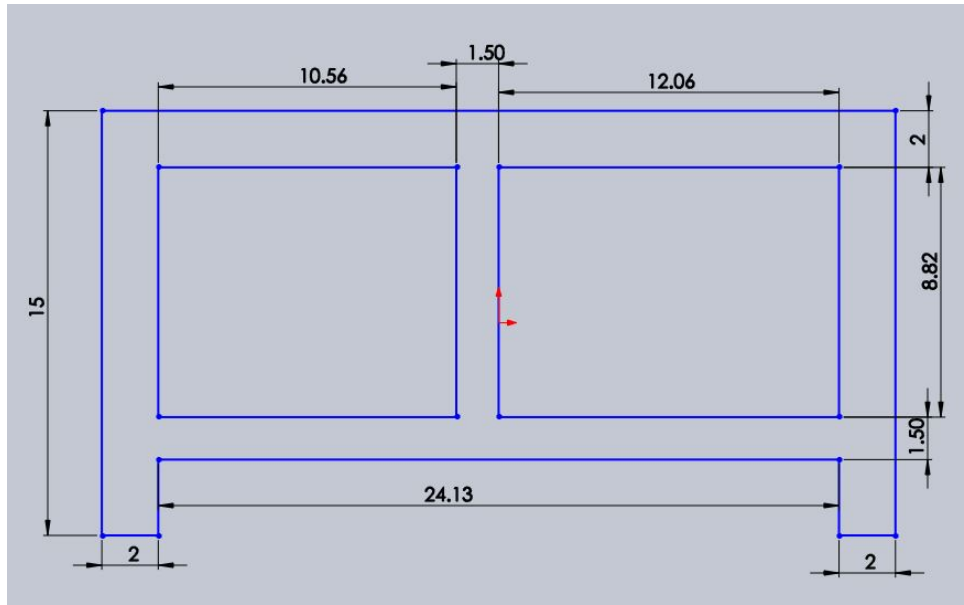

Figure 43 Extrudate dimensions (in mm)

As can be seen from the extrudate dimensions, the bottom section (1.5 mm) is thinner than other sections (2 mm) of the profile. Hence there will be relatively less flow in the bottom section (Figure 44 (a)). This reduction in flow can be addressed by increasing the thickness of the corresponding pre-land section as has already been discussed in previous literature [7].

After correcting the pre-land thickness for the bottom section, flow simulation was run.

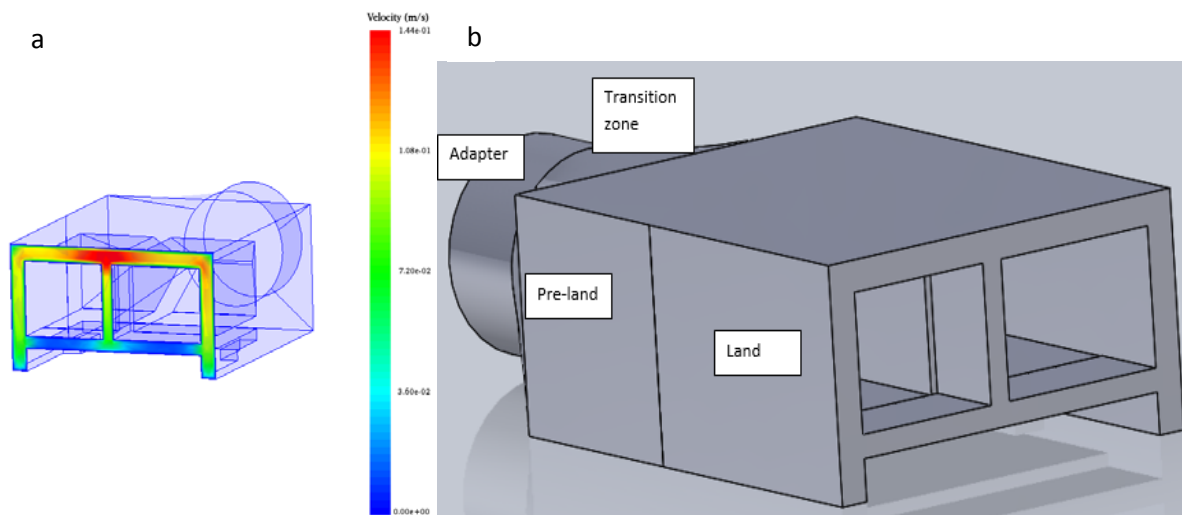

Figure 44 (a) Velocity plot (b) CAD model of initial extrusion die

Table 8 shows the boundary conditions while running the flow simulations. Figure 45 (a), (b) show the flow simulation results.

Table 8 Boundary conditions

Parameter	Value
Mesh Size	1.5 mm
Mass flow rate	60 kg/hr.
Inlet temperature	465 K
Primary wall temperature	465 K
Material used	PVC REZ57

As can be seen from Figure 45 (a), flow is concentrated at the T-junctions between the internal and external wall sections. Due to the increase in effective thickness of the flow channel near a T-junction, flow is typically faster in the T-junction. To prevent this build-up, pre-land channels feeding the land region need to be isolated from each other through out their length.

The modified die employing flow separators to isolate the pre-land channels is shown if Figure 46 (a), (b), (c). Figure 47 (a), (b) show the flow simulation results through the modified die.

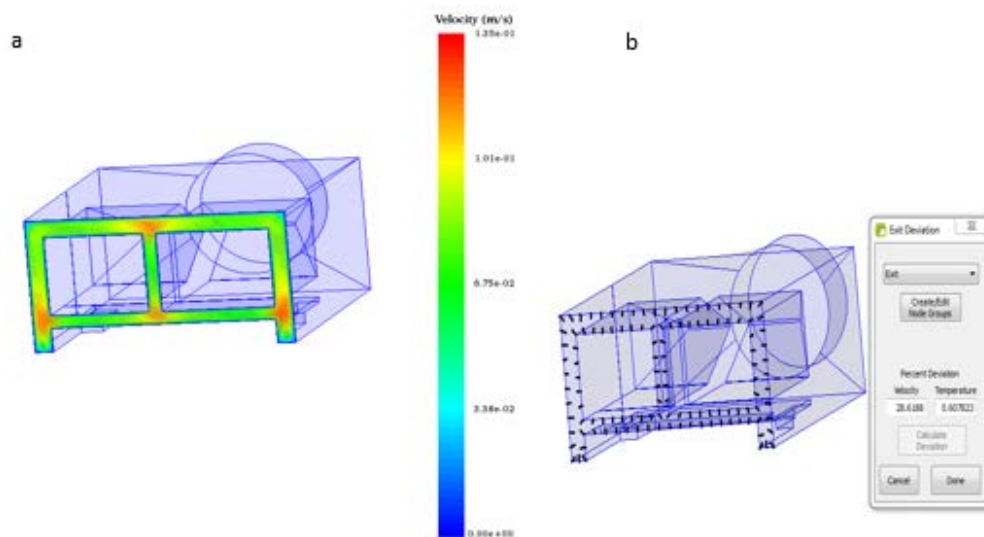
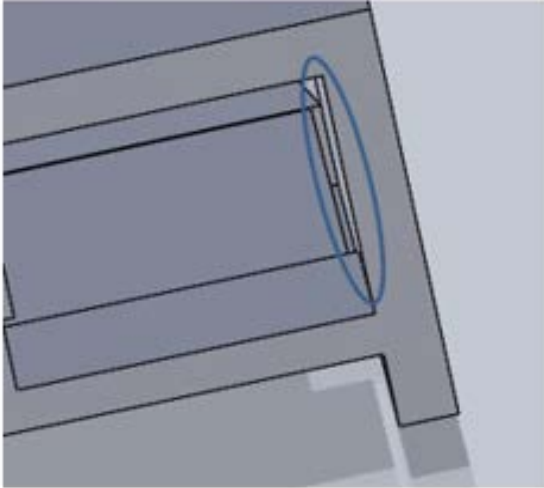
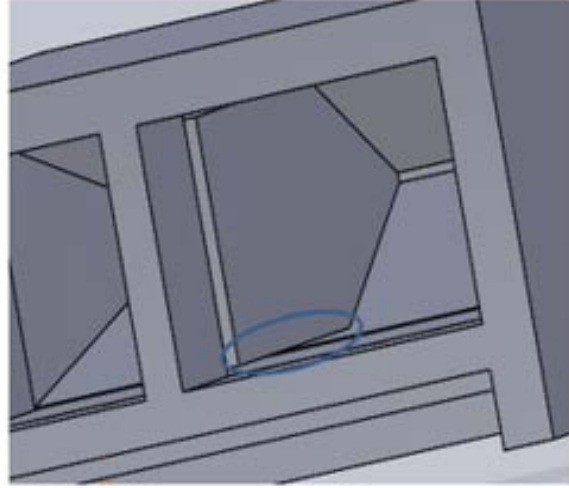

Figure 45 (a) Velocity plot (b) Exit deviation measured in the final die

a.



b.



c.

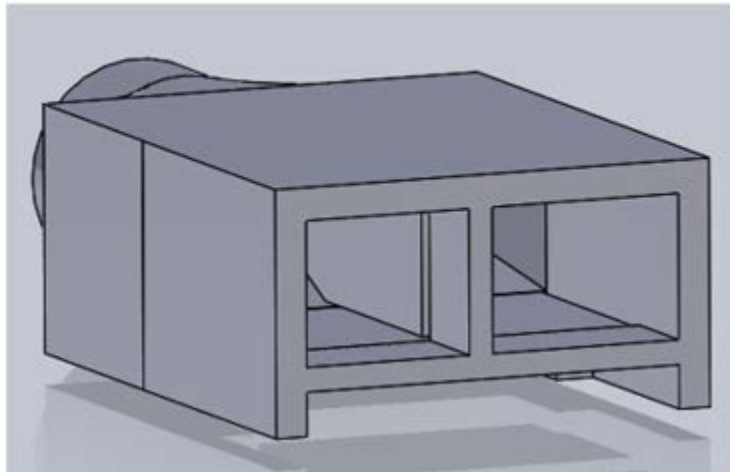

Figure 46 (a), (b), (c) Modified extrusion die with pre-land flow separators

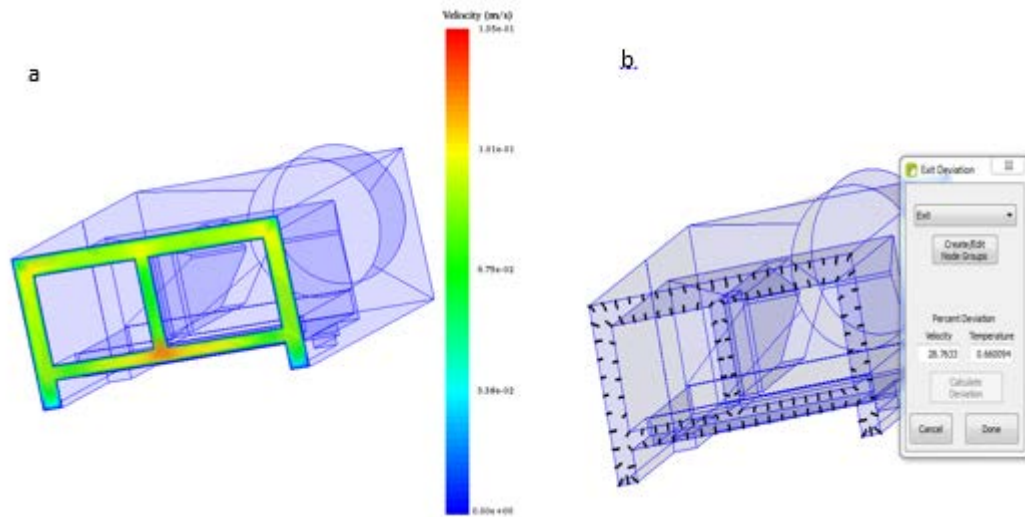

Figure 47(a) Velocity plot (b) Exit deviation measured in the final die

As can be seen from Figure 47 (a) the velocity at the exit face is more balanced due to a reduction in concentration of flow at the junctions. However, the exit deviation value has not changed much, 28.61 (original) and 28.76 (modified). This might be attributed to the formula used for calculating exit deviation which is based on the number of nodes in the exit face. Since the number of nodes at the junctions are small, any improvement in their velocity profile might not be depicted accurately by the exit deviation parameter.

Furthermore, there is still a minor imbalance in the bottom junction of the die which is addressed in the next design guideline.

5.2.4 Design Feature 5: Corner Projections

As can be seen from the die designed in the last section, there is a high concentration of flow at the bottom junction of the die. To overcome this, it is proposed that minor projections should be introduced upstream of the junction. Figure 48 (a), (b) shows a modified die with the proposed projections.

Figure 49 (a), (b) shows the flow simulation results through the modified die (boundary conditions used in section 5.2.3 are applied here also).

a

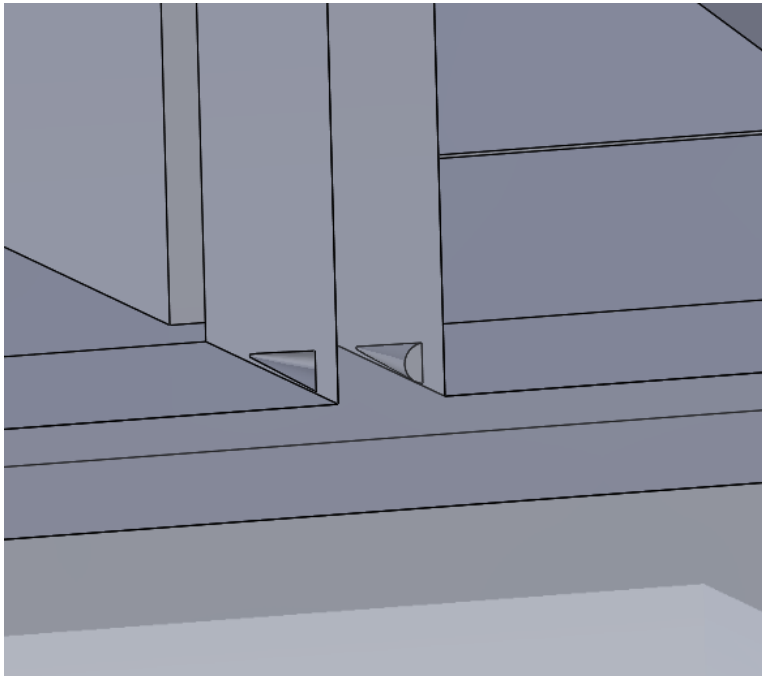

b

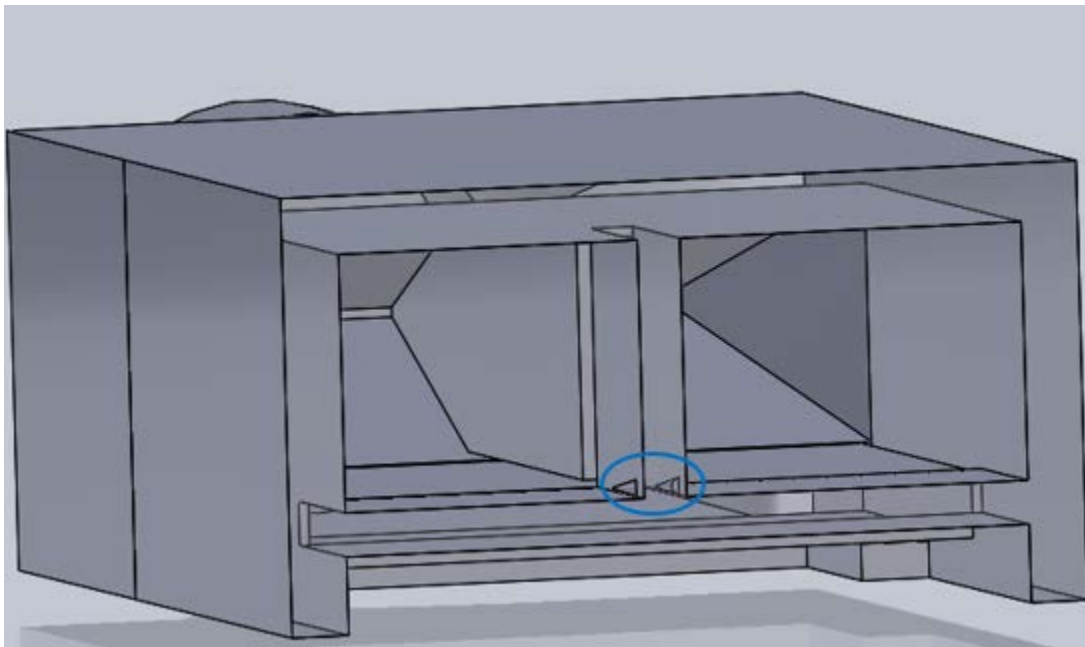

Figure 48 (a), (b) Modified die with projections upstream (Front face made transparent to show projections)

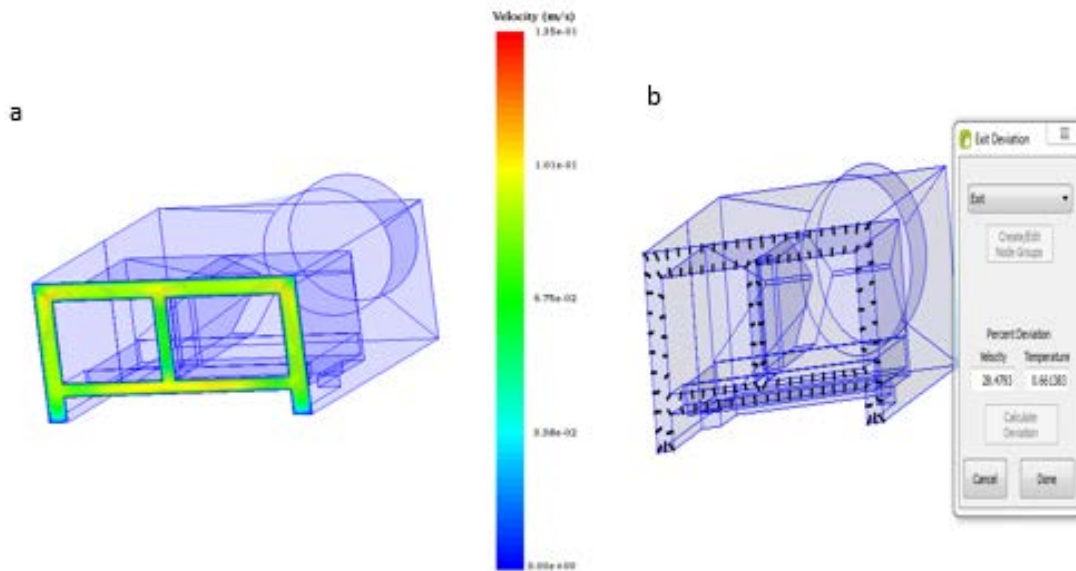

Figure 49(a) Velocity plot (b) Exit deviation in the final die

As can be seen from Fig. 49 (a), the flow is now balanced in the bottom section of the die. The projections upstream provide increased restriction to flow, thereby reducing the magnitude of flow and improving the velocity profile across the bottom junction of the exit face.

However, the exit deviation value has not changed much 28.76 (original die) to 28.47 (modified die). The reason for which is discussed at the end of previous section.

5.2.5 Design Feature 6: Drafting channels

In addition to having a uniform velocity profile at the exit of the die, it is important to avoid stagnant flow (dead zones) in an extrusion die.

Figure 50 shows the dimensions of the extrudate to be manufactured, and Figure 51 shows a CAD model of the die required to produce this extrudate.

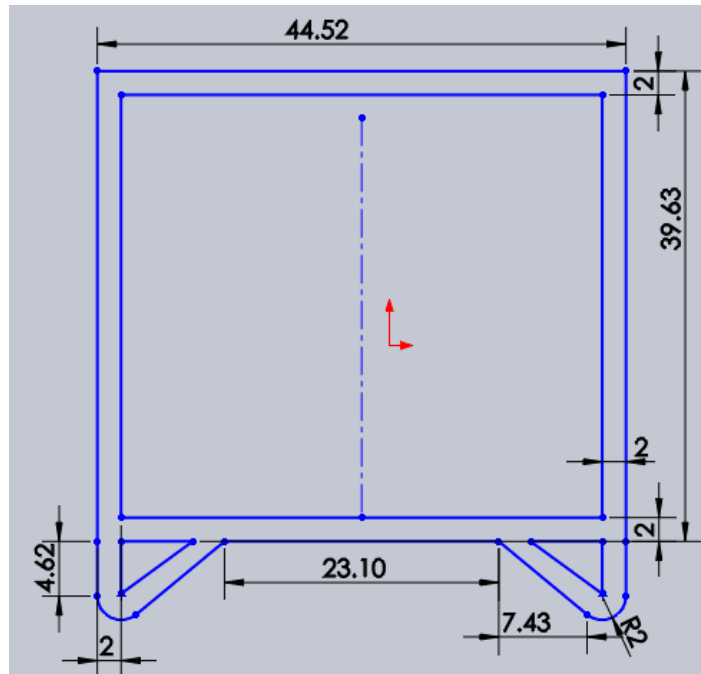

Figure 50 Extrudate dimensions (in mm)

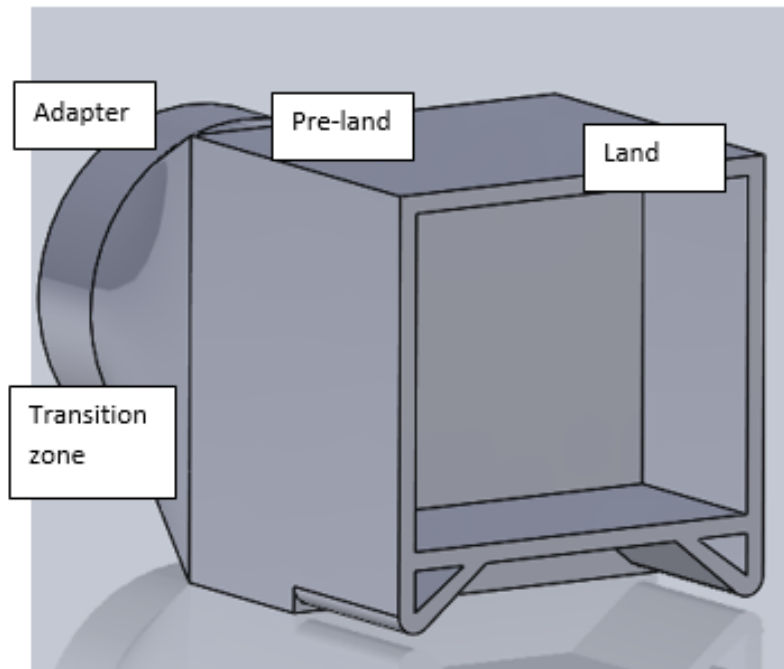

Figure 51 Initial extrusion die CAD model

As can be seen from the extrudate dimensions, all sections have uniform thickness and hence the exit velocity is expected to be reasonably uniform. Flow simulation was run to validate the

uniform velocity assumption. Table 9 shows the boundary conditions while running the flow simulations. Figure 52 (a), (b) show the flow simulation results.

Table 9 Boundary conditions

Parameter	Value
Mesh Size	2 mm
Mass flow rate	60 kg/hr.
Inlet temperature	465 K
Primary wall temperature	465 K
Material used	PVC REZ57

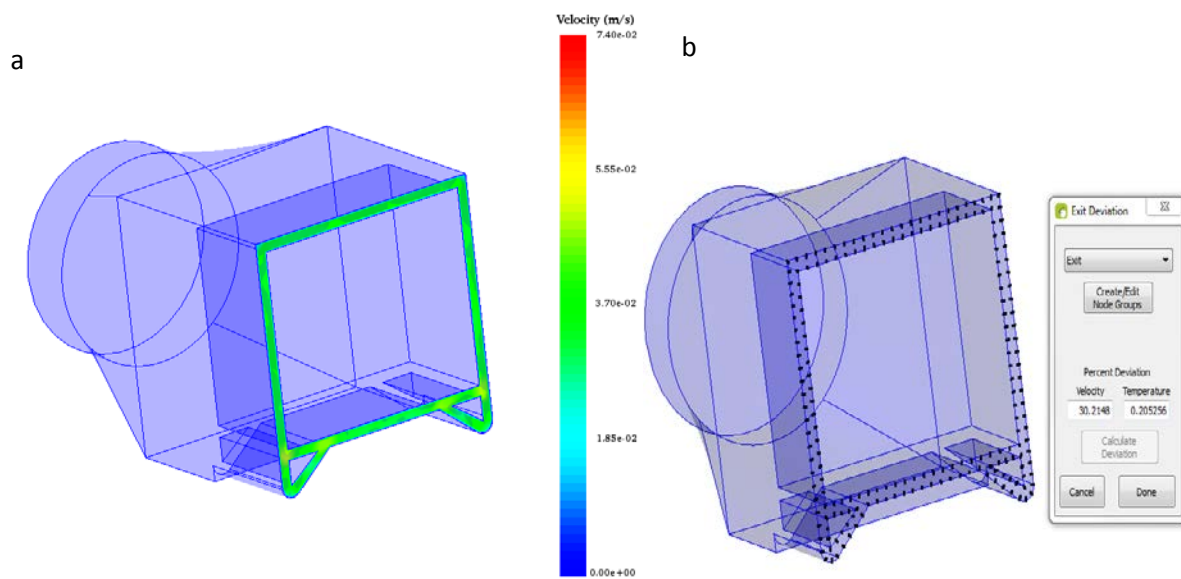

Figure 52(a) Velocity plot (b) Exit deviation measured in the initial die

As can be seen from Figure 52 (a), (b) the velocity at the exit face is quite balanced. Figure 53 shows the design of the flow channels in the transition zone, pre-land and land regions of the die.

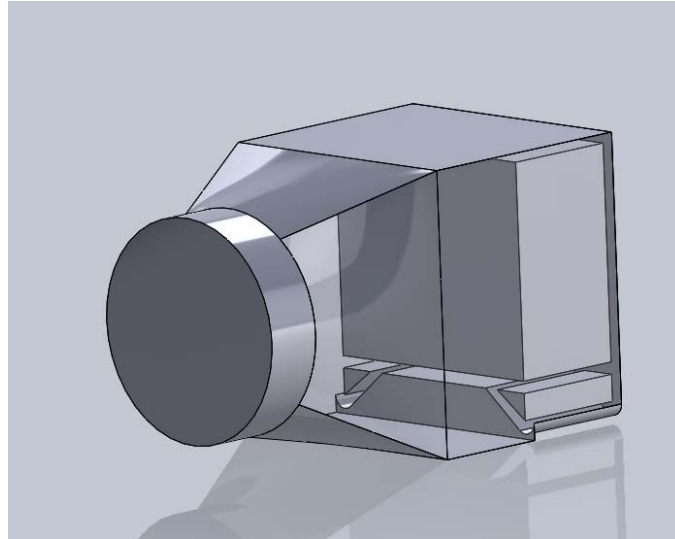

Figure 53 Flow channel design (Side faces are made transparent)

As can be seen from fig. 53, the flow changes from a circular cross-section to square cross-section (transition zone), followed by an abrupt change from square cross-section to required extrudate cross-section (pre-land and land regions). A recirculating stagnant flow is expected in this region (Figure 54) with abrupt reduction in area of the flow channel. To eliminate this stagnant flow it is proposed to put a draft angle on the square cross-section and other minor sections below it to get a slowly converging flow in this area.

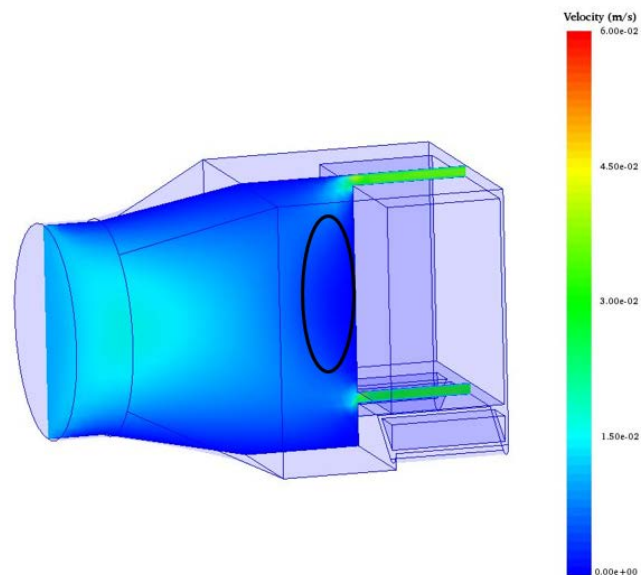

Figure 54 Flow simulation showing dead spots

To address this concern, it is proposed to having drafting flow channels, as shown if Figure 55, to have a smooth transition of flow. As can be seen from Figure 56, which shows the flow simulation through this modified die having drafting flow channels, there are no major dead spots in the transition region of the die.

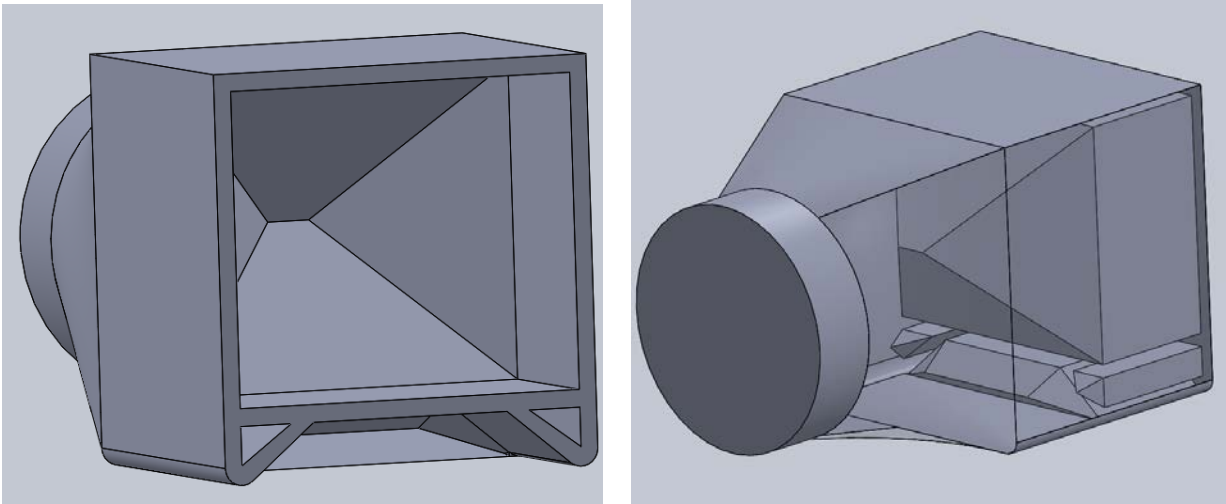

Figure 55 Modified die with drafting flow channel geometry

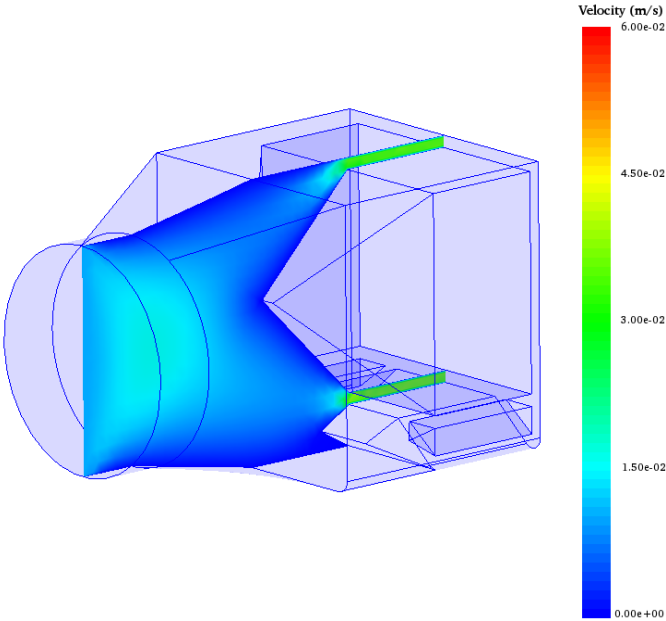

Figure 56 Flow simulation of modified die with no dead spots

5.2.6 Design Feature 7: Thin land for co-extrusion

Co-extrusion is a process in which more than one polymer enters the same die cavity, to form an extrudate having layers of different polymers. It is critical to control the thickness of different polymer layers in a co-extrusion process.

Figure 57 shows the required dimensions of an extrudate, whose top surface is a combination of virgin and re-cycled PVC REZ57. Figure 58 shows a CAD model of the die developed to produce this extrudate.

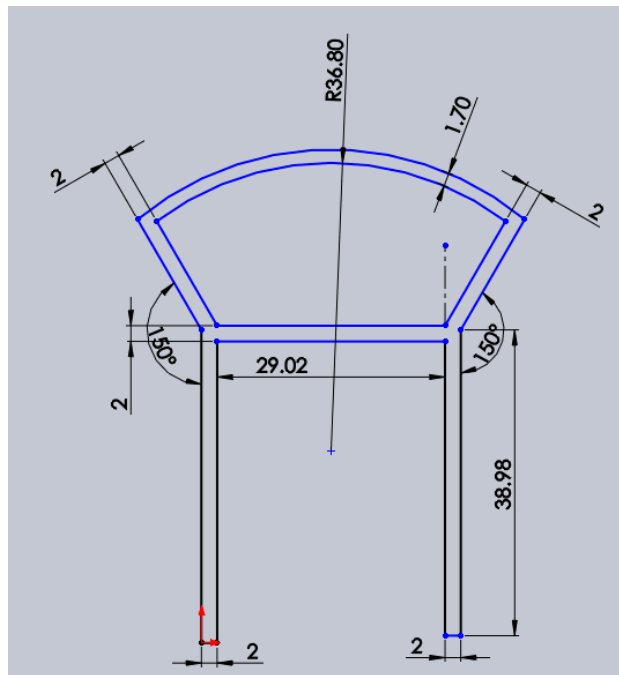

Figure 57 Extrudate dimensions (in mm)

As can be seen from the extrudate dimensions, all the sections have a uniform wall thickness, with the second polymer entering from above the top face. This guideline focuses on how to achieve a uniform distribution of second polymer on top face of the profile.

Flow simulation is run through the given die and results are shown in Figure 59 (a), (b).

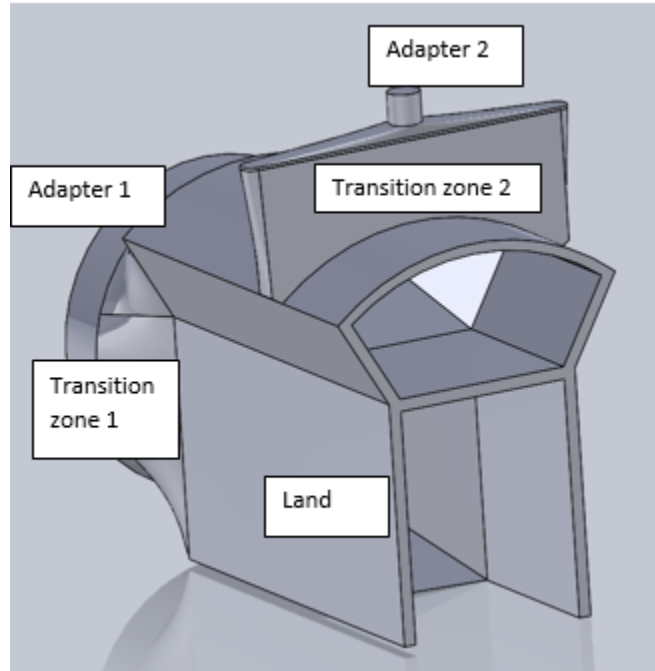

Figure 58 CAD model of initial co-extrusion die

Table 10 shows the boundary conditions while running the flow simulations. The material used is virgin PVC REZ57 in main entrance (1), and recycled PVC REZ57 in the top entrance (2).

Table 10 Boundary conditions

Parameter	Value
Mesh Size	2 mm
Mass flow rate 1	60 kg/hr.
Mass flow rate 2	10 kg/hr.
Inlet temperature 1	465 K
Inlet temperature 2	465 K
Primary wall temperature	465 K

As can be seen from the flow simulation results (Figure 59(a)), there is an increased flow concentration in the middle of the top section of the profile. This can be attributed to non-uniform distribution of polymer which is entering from entrance 2 of the die.

As can be seen from, Figure 60 a, b which show the flow velocity profile at entrance 2 cross-section of the die, maximum flow is concentrated in the middle region, and there is very little flow at the edges of the channel.

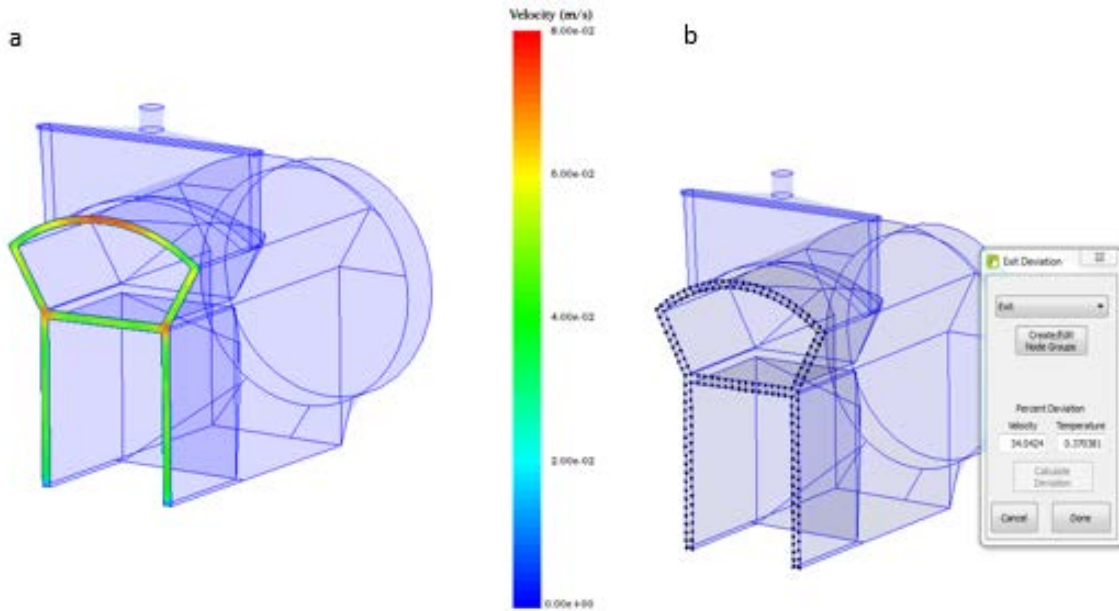

Figure 59(a) Velocity plot (b) Exit deviation measured in the initial die

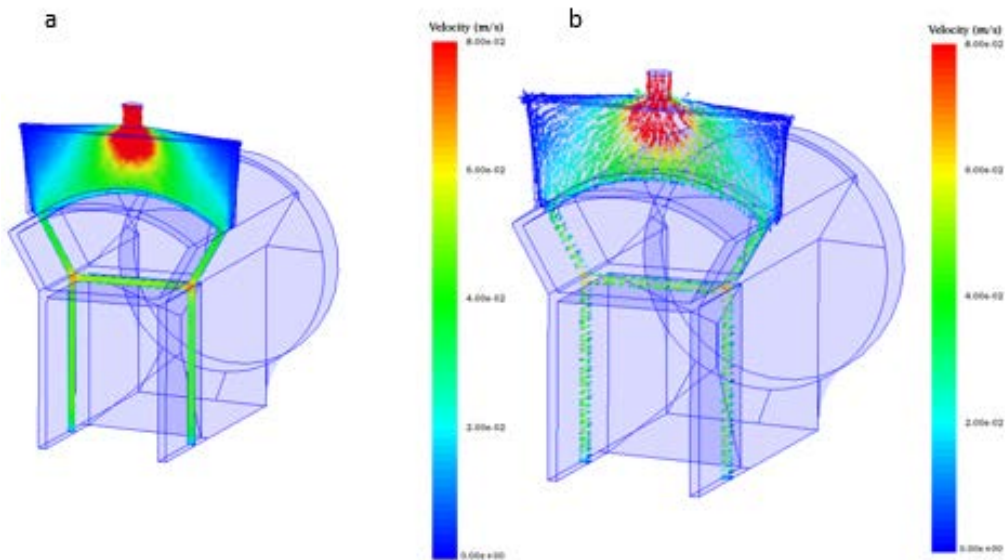

Figure 60(a) initial velocity plot at entrance 2 cross-section (b) initial velocity vector plot at entrance 2 cross-section

To improve the flow distribution at entrance 2 a modified die as shown in Figure 61 is proposed.

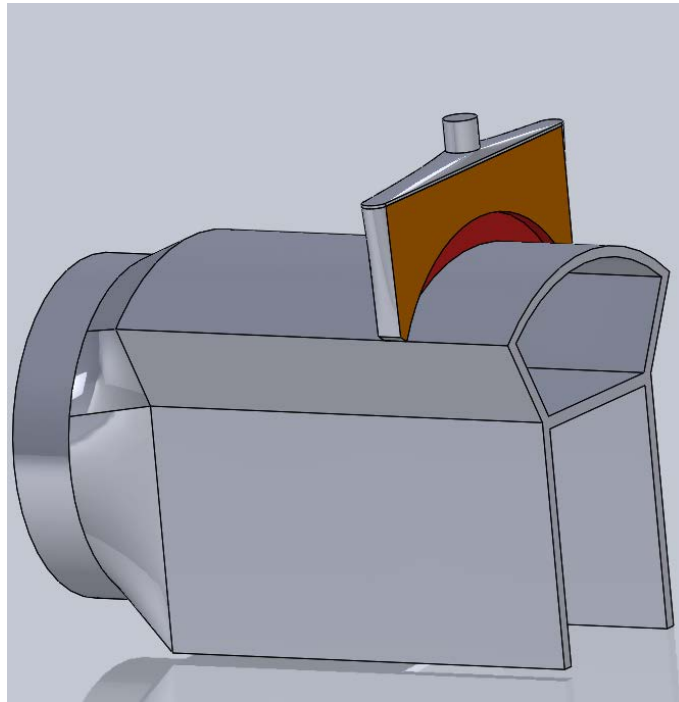

Figure 61 Modified co-extrusion die CAD model

The main entrance channel (orange) is followed by a thin section (red) before entering the die. This thin section distributes the flow more evenly, and hence the flow front entering the die has a more uniform velocity profile. However, the pressure drop for polymer entering the die from the second channel increases and hence it necessary to optimize the thickness of the entrance section.

It can be seen from Figure 62 (a), (b) which show the flow distribution at the entrance 2 cross-section of the modified die that the flow distribution has improved as compared to the original die. The thin section following the initial transition zone serves to redistribute the flow, owing to an increased pressure gradient.

Figure 63 (a) shows the exit velocity profile of the modified die. There is an improvement in the velocity profile of this die as compared to Figure 59 (a). However, the top section still has higher velocity compared to the other sections of the die, which can be corrected by adding a pre-land zone having lower thickness in the top section. (further discussed in section 6)

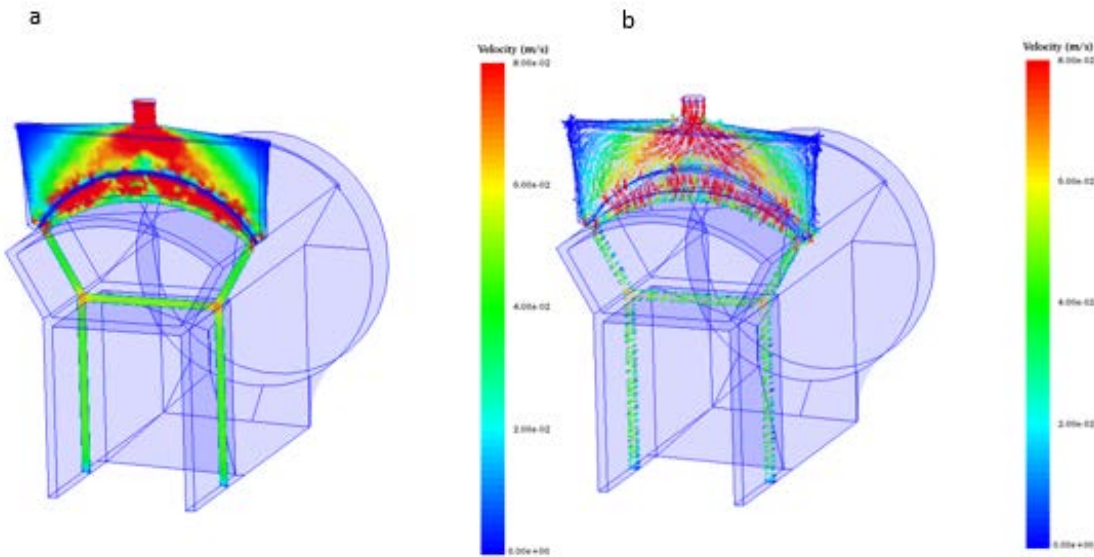

Figure 62(a) final velocity plot at entrance 2 cross-section (b) final velocity vector plot at entrance 2 cross-section

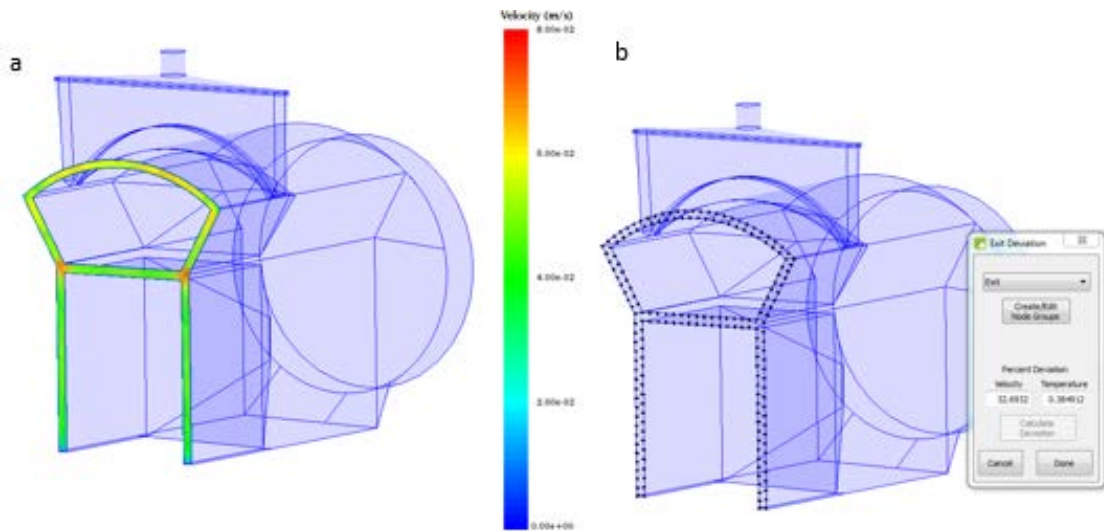

Figure 63(a) Velocity plot (b) Exit deviation measured in the final die

The above results can be quantified by a change in the exit deviation value which has decreased from 34.04 (original die) to 32.69 (modified die).

Another important aspect for co-extrusion dies is the shape of the layer structure in the extrudate. As can be seen from Figure 64 (a), (b) which shows the structure of the interface between the two layers for the initial die, the polymer layer on the top has a non-uniform

distance from the bottom face, with the middle section of the layer relatively closer to the bottom face and the layer sections near the extreme ends are relatively farther from the bottom face. Furthermore, as can be seen from Figure 64 (c), (d), which shows the combining layer structure for the modified die, the layer structure has a more wavy shape but a constant distance from the bottom face, except for the end sections of the layer which are closer to the bottom face.

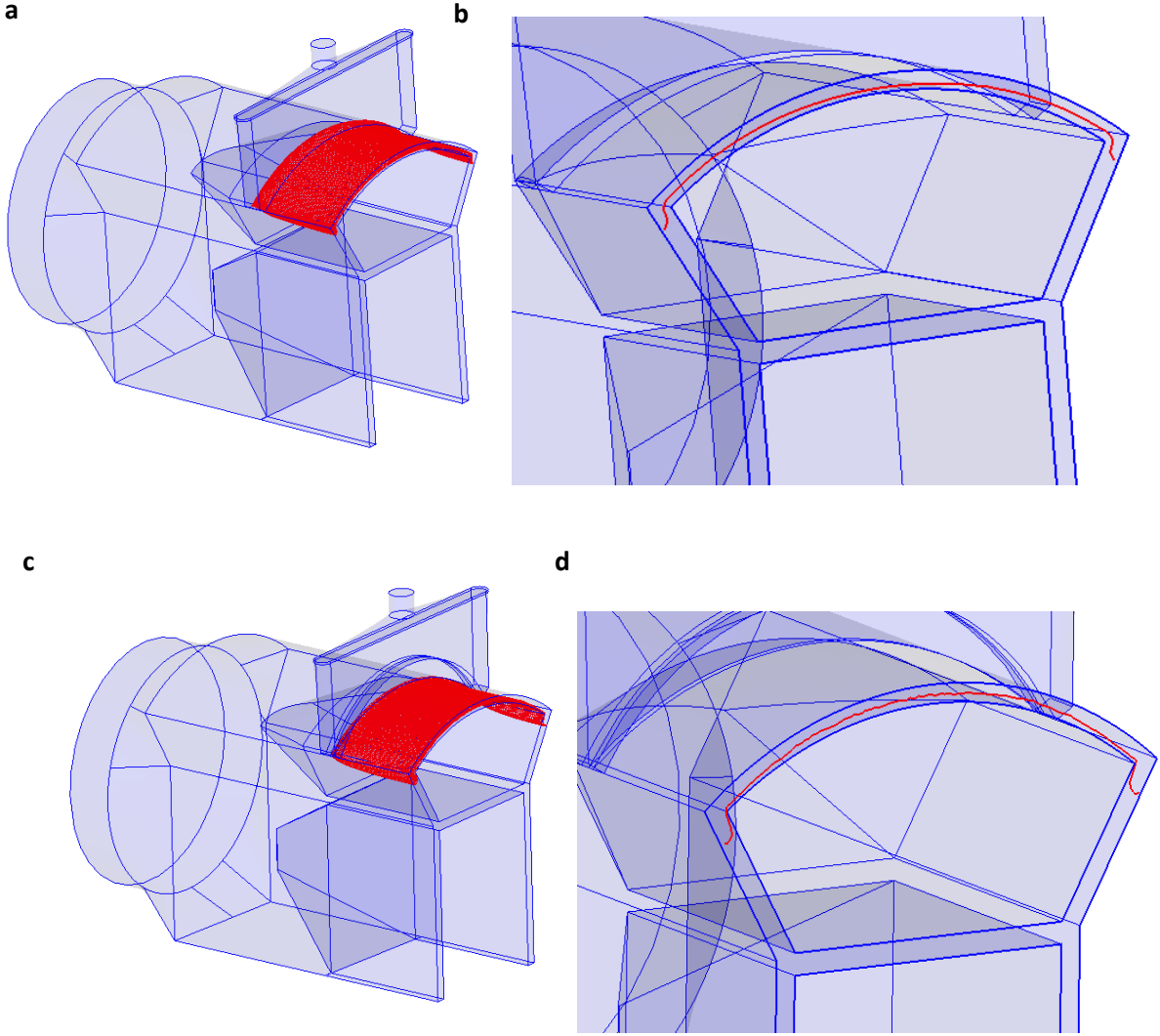

Figure 64 (a), (b) layer structure for initial die (c), (d) layer structure for final die

6. Automatic Die Optimization

An introduction to automatic extrusion die optimization is given in section 4.2 of this report. In the following sections automatic optimization technique is employed to various mono extrusion and co-extrusion dies.

The goal of this section is to prove the successful application of automatic optimization technique in polyXtrue, while using proven die design strategies like the “elemental sections method” and “avoid cross flow strategy”, which were introduced in sections 2.3.1 and 2.3.2 respectively.

6.1 Elemental Sections Optimization 1

In this section the elemental sections method is implemented to optimize the die geometry for a given profile. Figure 65 shows a profile geometry having three different section thickness and lengths. This geometry is divided into three elemental sections based on the thickness values. As per the elemental sections method, the two parameters which need to be adjusted include pre-land channel thicknesses and land lengths for each elemental sections.

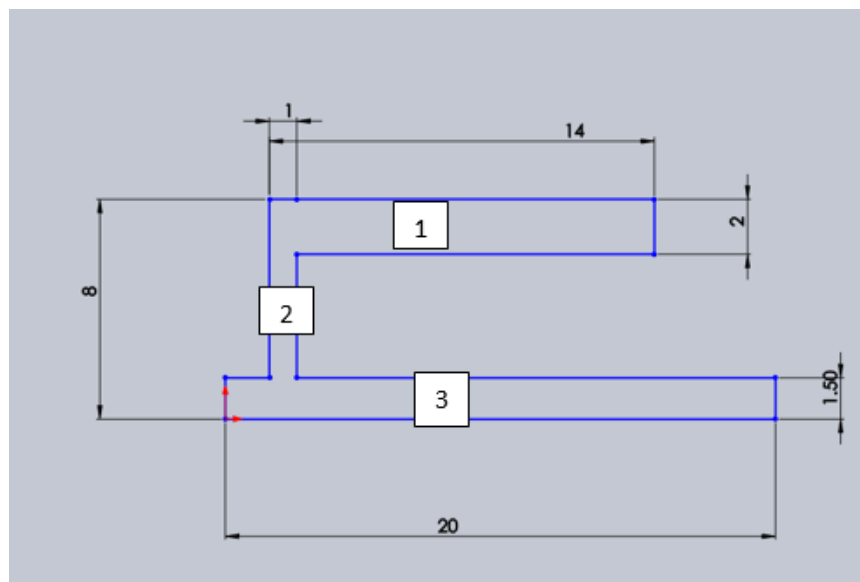

Figure 65 Extrudate dimensions (in mm)

For a thicker pre-land section (compared to land section thickness), increase in land length causes and increase in flow resistance thereby decreasing the exit velocity of that particular section. This

concept is used by the optimization algorithm to balance the exit velocity and arrive at the required parameter dimensions.

Figure 66 shows a CAD model of the initial die, with all three sections having equal land length (6mm) and pre-land thicknesses (1 mm).

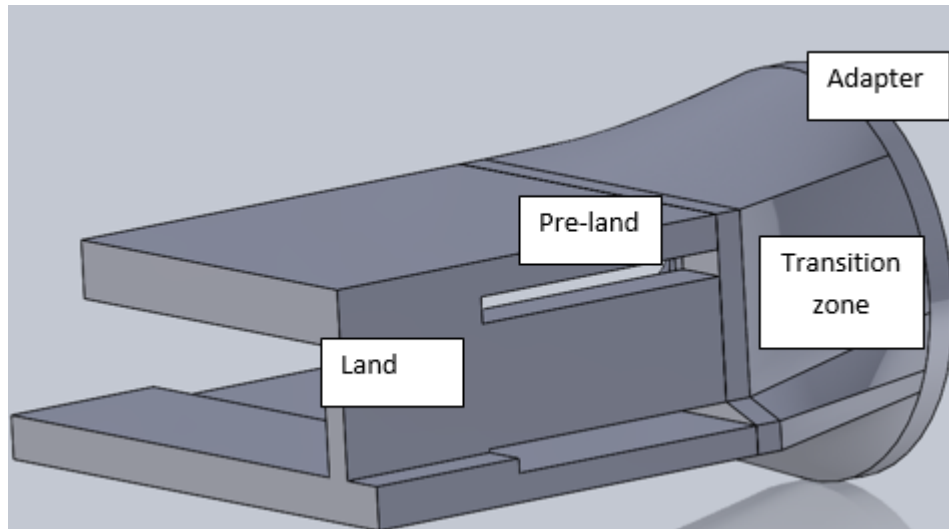

Figure 66 CAD model of initial extrusion die

Since elemental section 1 has the maximum thickness, polymer flow is expected to be concentrated in this region. Flow simulation was run to verify this assumption.

Table 11 shows the boundary condition values for the flow simulation. Figure 67 (a), (b) show the flow simulation results.

Table 11 Boundary conditions

Parameter	Value
Mesh Size	1mm
Mass flow rate	150 kg/hr.
Inlet temperature	455 K
Primary wall temperature	470 K
Material used	PVC REZ57

As can be seen from Figure 67 (a), polymer flow is concentrated in the thickest section of the profile. Also, when analyzing the flow it was found that there was a cross flow between land sections of the die which further imbalanced the exit velocity profile (refer Figure 68 (a), (b)).

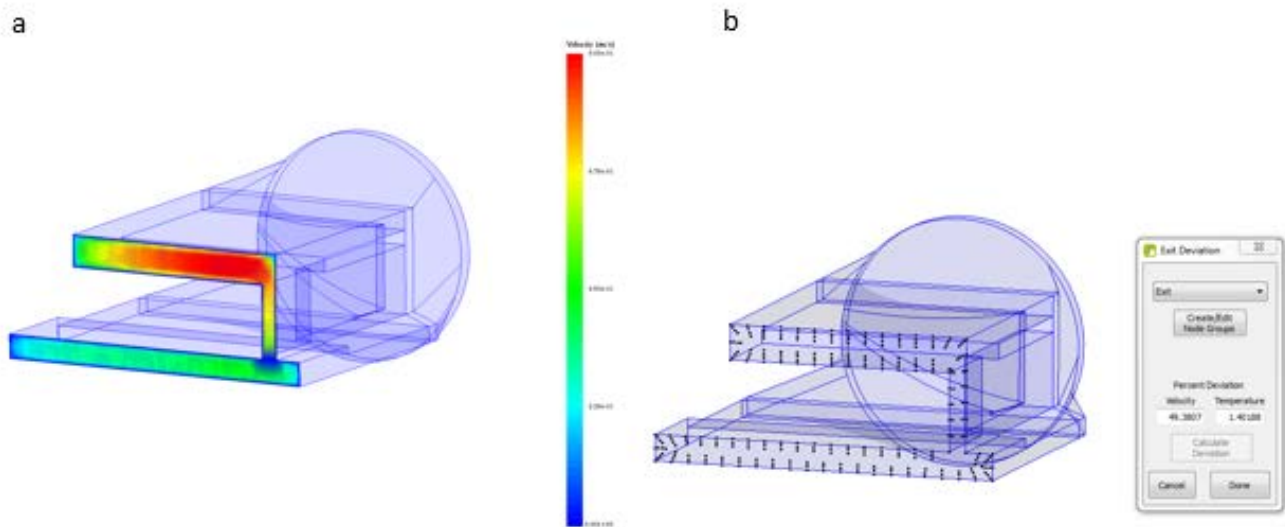

Figure 67(a) Velocity plot (b) Exit deviation measured in the initial die

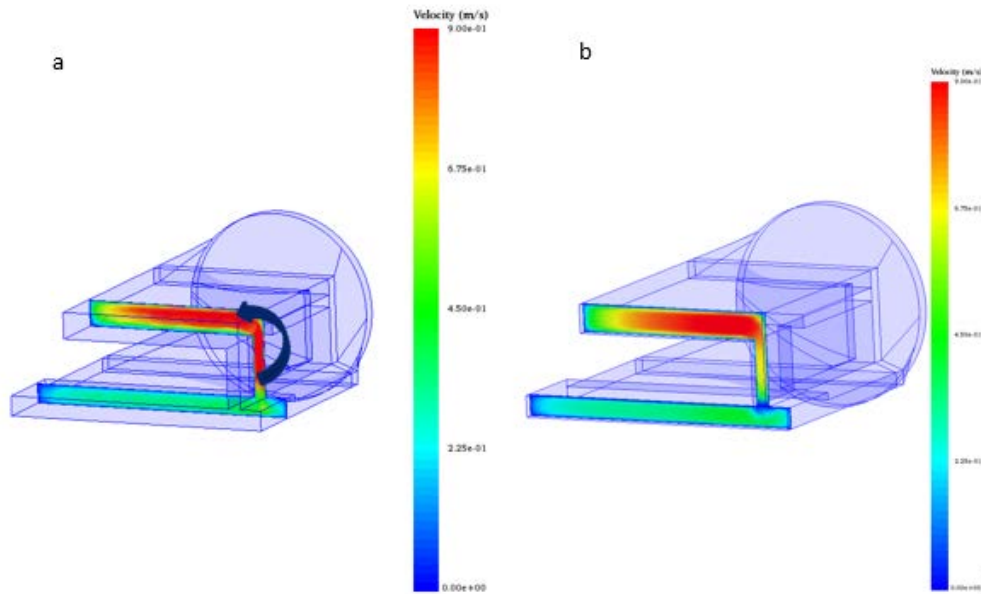

Figure 68(a) beginning of cross-flow (b) end of cross-flow

To reduce the cross-flow a flow separator (refer to Figure. 69) was added between sections 1 and 2. However, the length of flow separator was kept to a minimum possible value to avoid the formation of weak weld lines in the final extrudate.

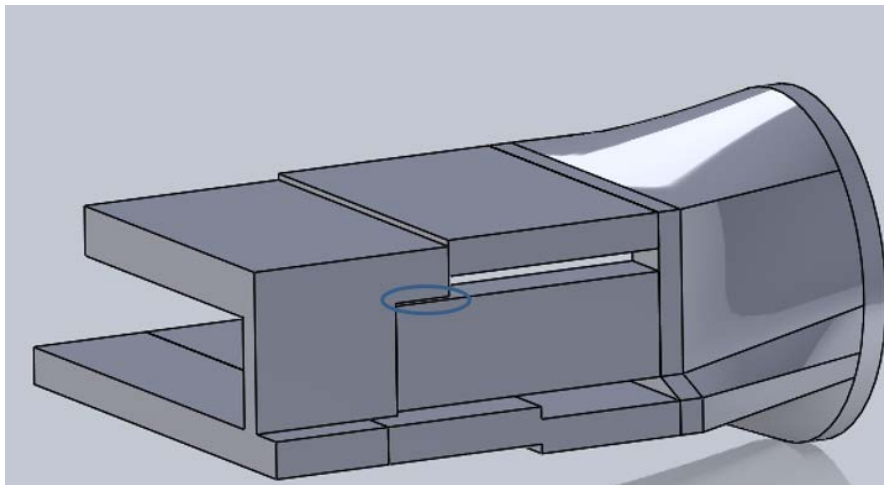

Figure 69 Modified die with flow separator

By employing a flow separator (feature separating flow in adjacent flow channels), the flow in section 2 was prevented from being diverted to section 1 of the die (refer Figure 70).

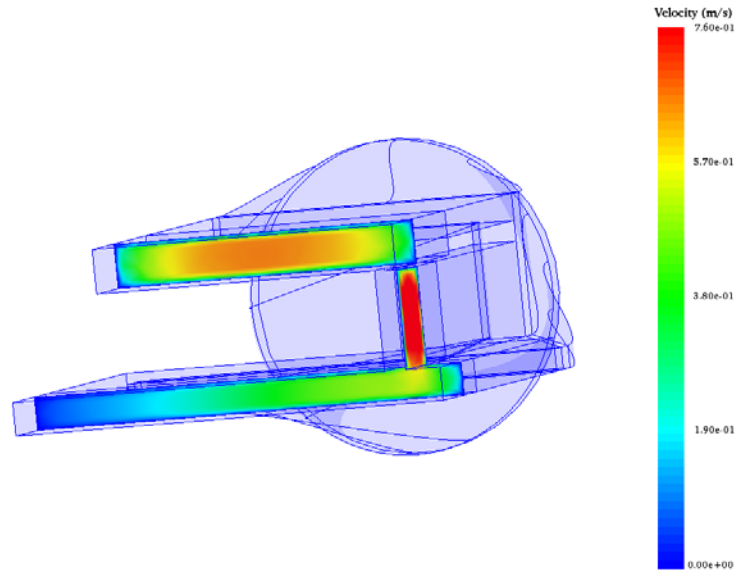

Figure 70 Prevention of cross-flow by adding a flow separator

The next step after modelling the flow separator was to optimize the land lengths and pre-land thicknesses of the three elemental sections of the die using the automatic die optimization technique available in polyXtrue software.

Table 12 shows the initial parameter values. (Refer to section 3.2 of the report, for the feature parameterization procedure)

Table 12 Initial parameter values

Parameter	Value
Land Length 1	6 mm
Land Length 2	6 mm
Land Length 3	6 mm
Pre-land thickness 1	1 mm
Pre-land thickness 2	1 mm
Pre-land thickness 3	1 mm

After parameterizing the die geometry it was imported into polyXtrue and the parameter ranges were specified (refer table 13). The number of flow simulations were then specified to enable automatic optimization.

Table 13 Parameter ranges

Parameter	Max. Value	Min. Value
Land Length 1	15 mm	1 mm
Land Length 2	15 mm	1 mm
Land Length 3	15 mm	1 mm
Pre-land thickness 1	3 mm	1 mm
Pre-land thickness 2	3 mm	1 mm
Pre-land thickness 3	3 mm	1 mm

Total of 30 simulations were carried out to optimize the 6 parameter values. It took 22 minutes of compilation time to run the simulations on a Dell Precision T1700 computer.

Table 14 shows the parameter values obtained after optimization. Figure 71 (a), (b) shows the flow simulation results for the optimized die.

Table 14 Optimized parameter values

Parameter	Value
Land Length 1	8.6507 mm
Land Length 2	6.2749 mm
Land Length 3	11.817 mm
Pre-land thickness 1	1.4498 mm
Pre-land thickness 2	2.1903 mm
Pre-land thickness 3	1.3856 mm

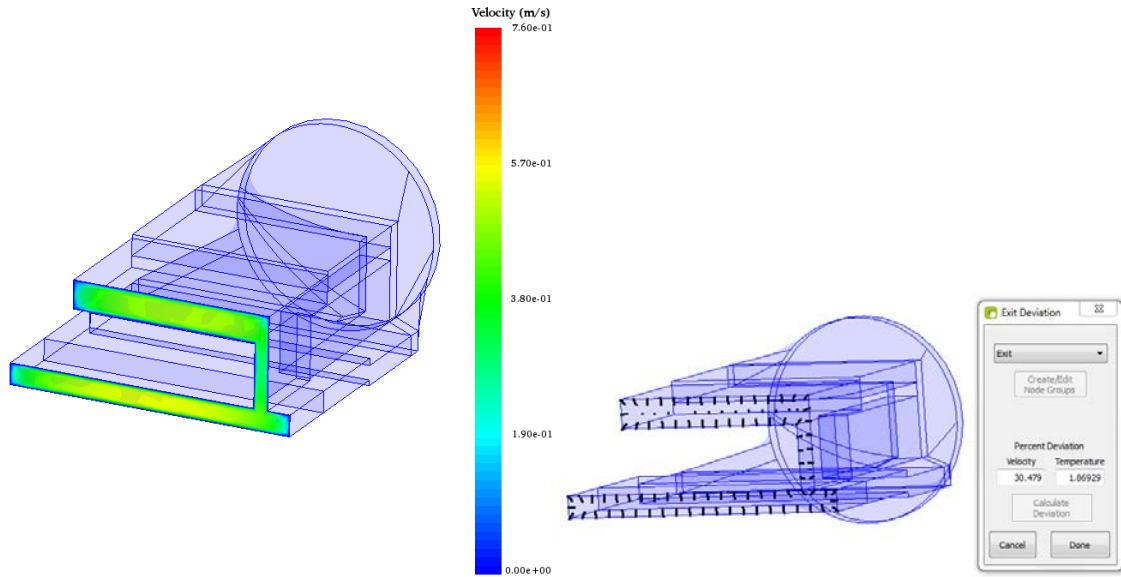

Figure 71(a) Velocity plot (b) Exit deviation measured in the final die

As can be seen from Figure 71 (a), the velocity profile for the exit face is more balanced as compared to Figure 67 (a). Hence the optimization code was successful in optimizing the land length and pre-land thickness values to obtain an optimum exit velocity profile. This result is quantified by a change in exit deviation value which decreased from 49.3 (initial) to 30.4 (optimized).

6.2 Elemental Sections Optimization 2

The extrudate shape which is used for optimizing the second die with elemental section method is shown in Figure 72. Figure 73 shows the CAD model of the die developed to produce this shape.

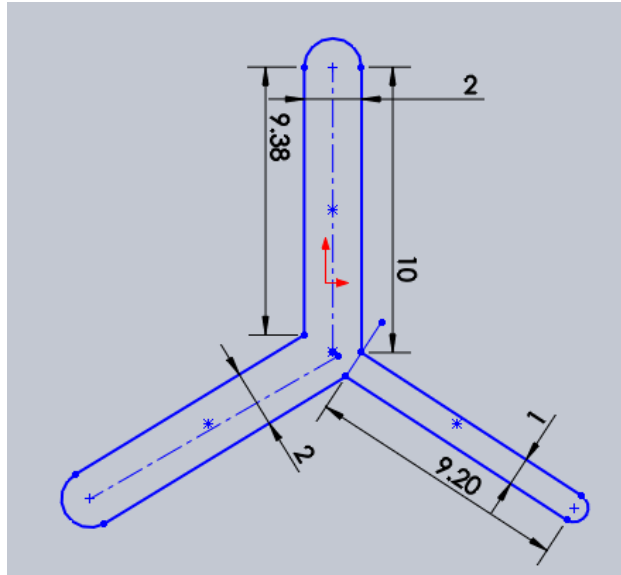

Figure 72 Extrudate dimensions (in mm)

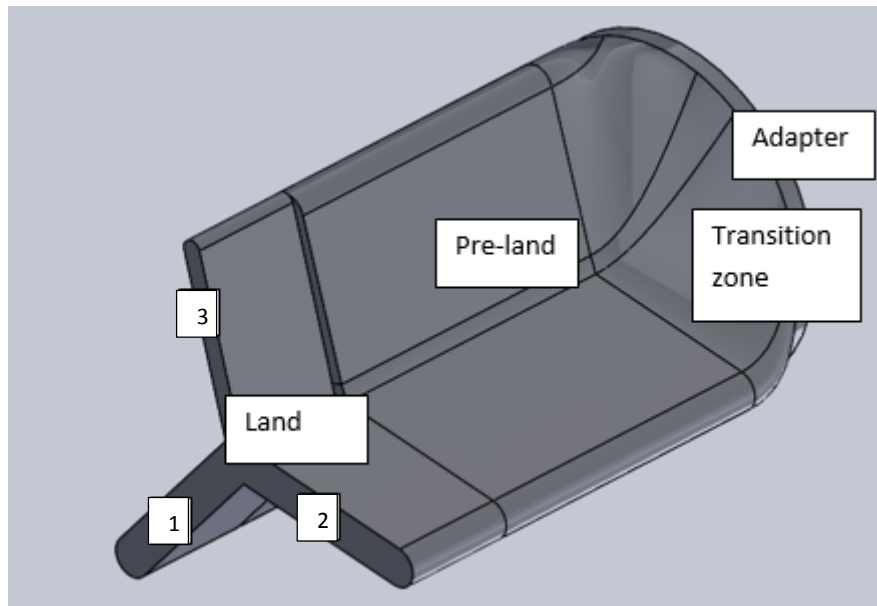

Figure 73 CAD model of initial extrusion die

For this profile shape there is expected to be a high concentration of flow at the junction of the three sections. In this case land length cannot be increased beyond a particular value since the flow will tend to be concentrated at the center of the profile due to cross-flow. Flow simulation was run to verify this assumption.

Table 15 specifies the boundary conditions which were used for simulating the flow. Figure 74 (a), (b), (c) show the results of flow simulation.

Table 15 Boundary conditions

Parameter	Value
Mesh Size	1mm
Mass flow rate	127 kg/hr.
Inlet temperature	455 K
Primary wall temperature	465 K
Material used	PVC REZ57

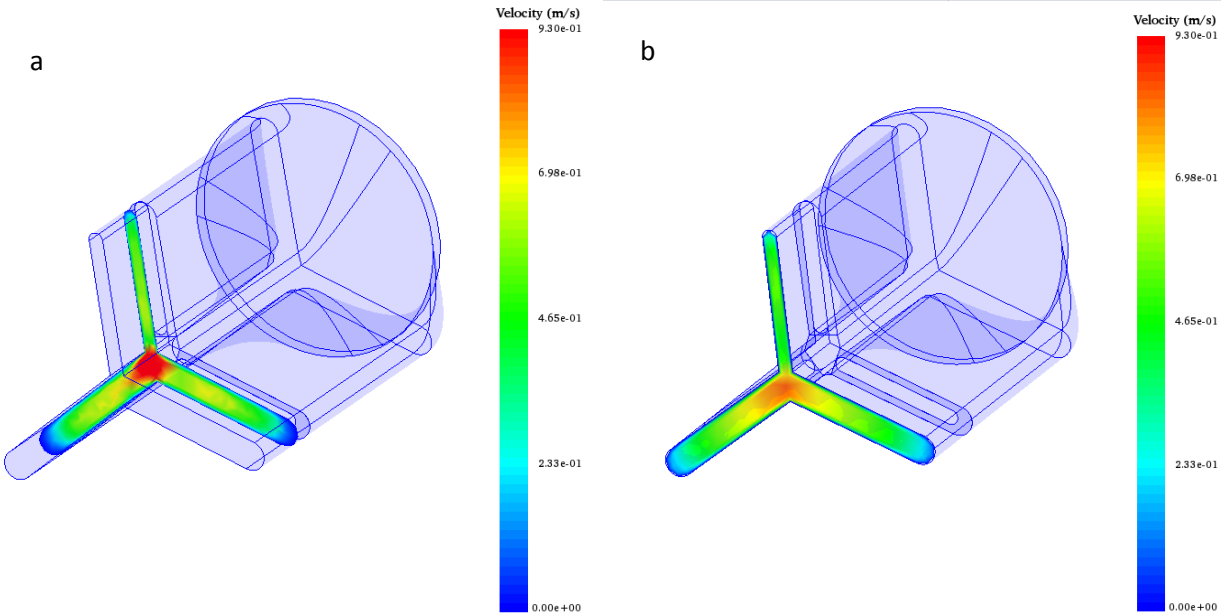

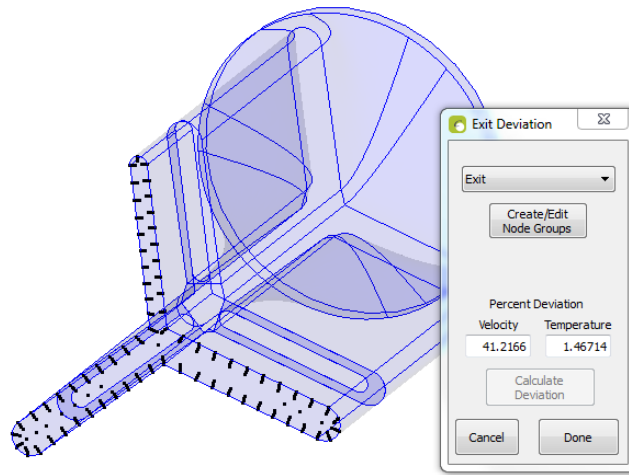

Figure 74 (a) velocity profile at the beginning of land section (b) velocity profile at exit of land section (c) exit deviation

As can be seen from Figure 74 (a), (b) the polymer tends to be concentrated at the intersection of the three sections. To overcome this concentration of flow at the junction of the die, a modified die with three independent feed channels comprising the pre-land section of the die was developed.

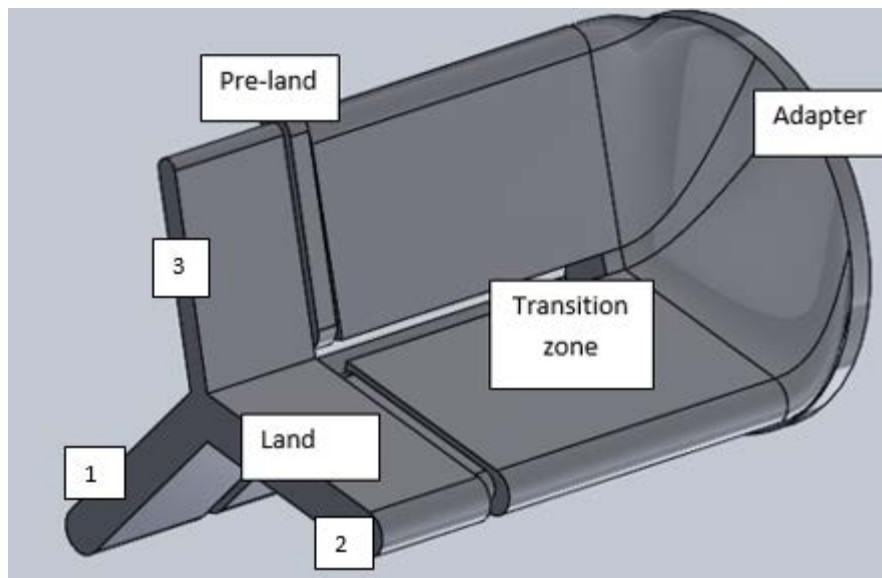

Figure 75 CAD model of modified die

After dividing the profile cross-section into three elemental sections, pre-land length and thickness were modified according to the elemental sections method. (Similar strategy as explained in section 6.1)

The required features were parametrized in Solidworks (refer section 3.2) and the resulting geometry was imported into polyXtrue and the parameter ranges were defined (Table 16).

Table 16 Parameter ranges

Parameter	Min. Value	Max. Value
Pre-land Length 1	1 mm	1.6 mm
Pre-land Length 2	1 mm	1.6 mm
Pre-land Length 3	1.6 mm	1.9 mm
Pre-land thickness 1	3 mm	10 mm
Pre-land thickness 2	3 mm	10 mm
Pre-land thickness 3	1 mm	3 mm

After setting the parameter ranges, number of iteration was specified to enable automatic optimization.

40 simulations were run to optimize the 6 parameter values, and it took 29 min. to run the simulations on a Dell Precision T1700 computer. Table 17 shows the parameter values post optimization. Figure 76 (a), (b) shows the flow simulation results.

Table 17 Optimized parameter values

Parameter	Value
Pre-land Length 1	1.307 mm
Pre-land Length 2	1.372 mm
Pre-land Length 3	1.794 mm
Pre-land thickness 1	7.49 mm
Pre-land thickness 2	7.714 mm
Pre-land thickness 3	1 mm

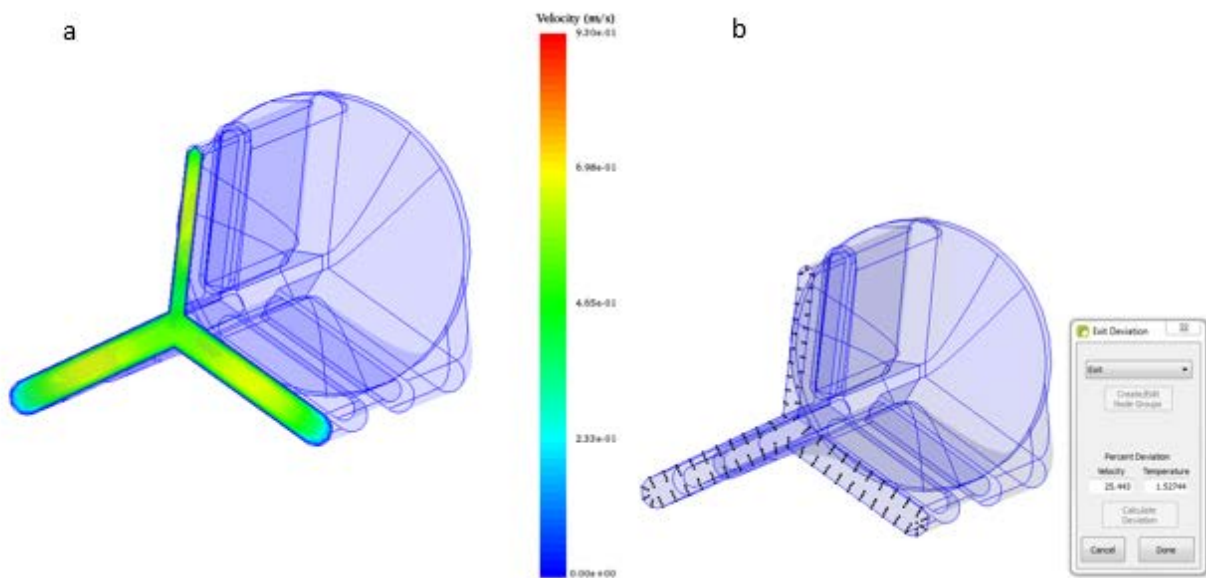

Figure 76(a) Velocity plot (b) Exit deviation measured in the final die

As can be seen from the optimized die flow simulations, the velocity profile at the exit is more uniform and the exit deviation value has been decreased from 37.4 (pre-optimization) to 25.4 (post optimization).

6.3 Avoid Cross-flow Strategy 1 (Mono Extrusion)

The “Avoid Cross-flow Strategy” (ACFS) for extrusion die balancing was briefly introduced in section 2.3.2 of this report. In this section, a detailed explanation of the application of this method is given.

A mono extrusion and co-extrusion die were designed for a complex profile shape, and the automatic die optimization option in polyXtrue was implemented to obtain the optimized die dimensions.

Figure 77 shows the dimensions of the extrudate shape for which the die is optimized in this section.

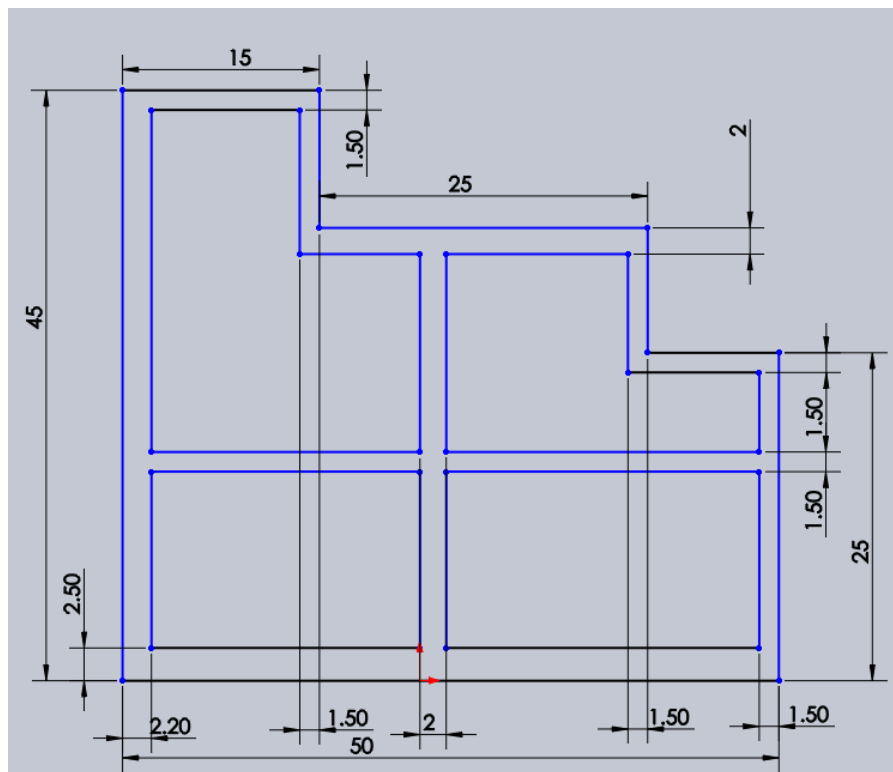

Figure 77 Extrudate dimensions (in mm)

As can be seen from Figure 77, different sections of the profile have different thickness, this causes an unbalanced flow at the exit with the thinner sections having a slower flow and the thicker sections having a faster flow. This unevenness in flow distribution imbalances the exit velocity profile and causes large distortion in the extrudate after the polymer leaves the die.

To balance the die, ACFS strategy was implemented. The following steps show how the die was designed using ACFS.

- Land design

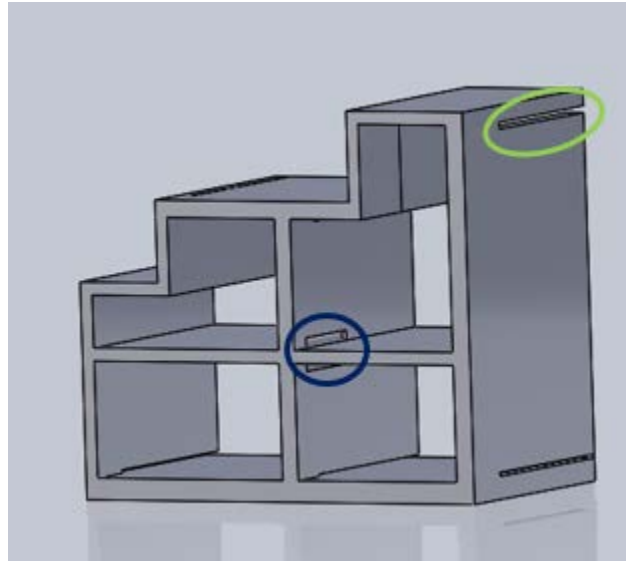

Figure 78 Die land

The land of the die has the same cross-section as that of the required extrudate throughout its length (Figure 78). The length of the land should be long enough to ensure that the resulting extrudate has the required mechanical strength, but should not be too long to enable high amount of cross-flow between profile sections which would lead to exit velocity imbalance.

Flow separators (green circle in Figure 78) are used to prevent cross flow to some extent. Projections (blue circle in Figure 78) as discussed in design feature 5, are implemented to avoid concentration of flow at junctions.

As per ACFS, the land exit cross-section (same as extrudate shape) is divided into partitions called design variables (DV's). Each DV corresponds to a section of the profile and has dimensions different from the adjoining DV's. In this case the exit face is divided into 10 DV's (refer Figure 79). Each color on the exit face of the die in Figure 79, is used to represent a particular DV.

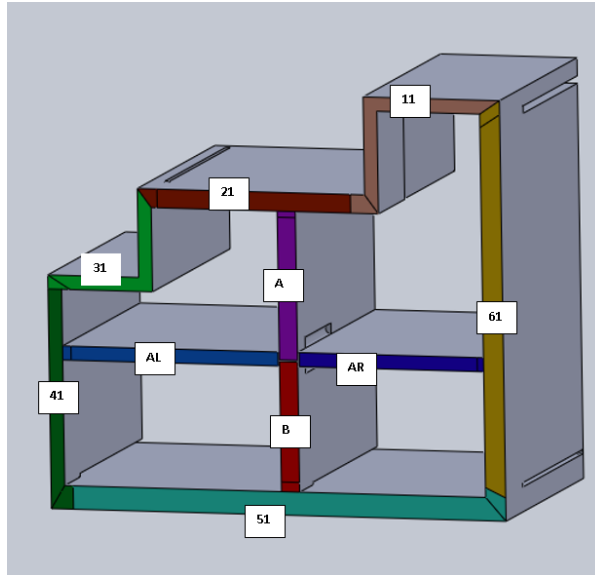

Figure 79 Division of exit face into DV's

- Pre-land design

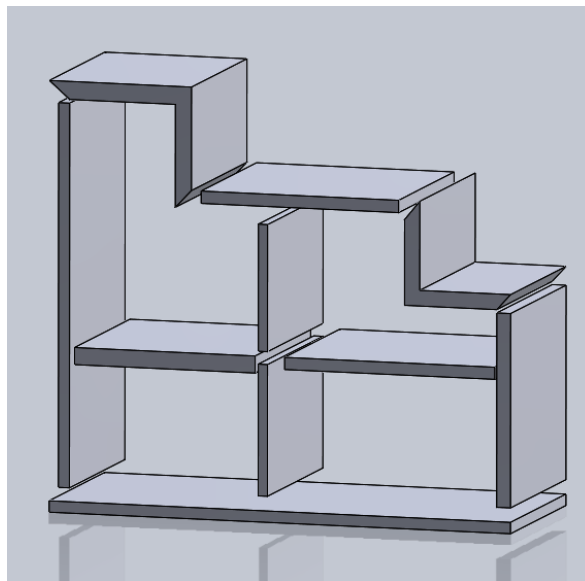

Figure 80 Die pre-land

The pre-land region of the die is used to control flow in specific sections of the die. As per ACFS, the pre-land consists of independent flow channels each feeding a particular DV. There may be more feed channels than the number of DV's in case of extrusion die having intricate shapes. Also, the number of feed channels can vary across the pre-land land length, with different feed

channels combining downstream the pre-land section. For the die analyzed here there are 10 flow channels feeding the 10 DV's in the land region of the die. Figure 81 shows the pre-land flow channels which are denoted by the same notation as that of the DV they are feeding.

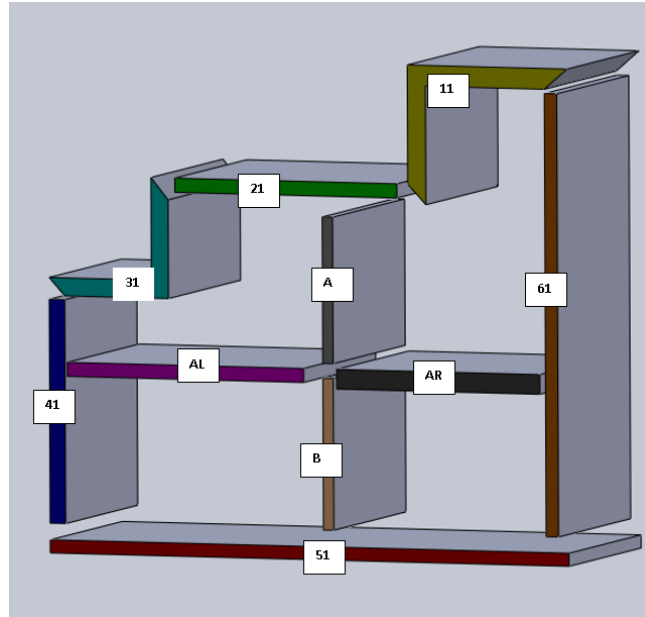

Figure 81 Pre-land flow channels

For a balanced die, the percentage of flow through a given DV (at the exit face) is equal to the percentage of total exit face area that the particular DV represents. Accordingly, the dimensions of various feed channels are calculated such that the percentage of flow through a given feed channel is equal to the required flow at the DV to which the feed channel is supplying. The sizing of the pre-land sections is discussed later in this section.

- Transition Zone

The transition zone of the die is the region where the flow is modified from a circular shape to one which closely resembles the outline of the required extrudate. This region generally has a complex shape for profile extrusion dies, but does not play a critical role in determining the exit velocity distribution.

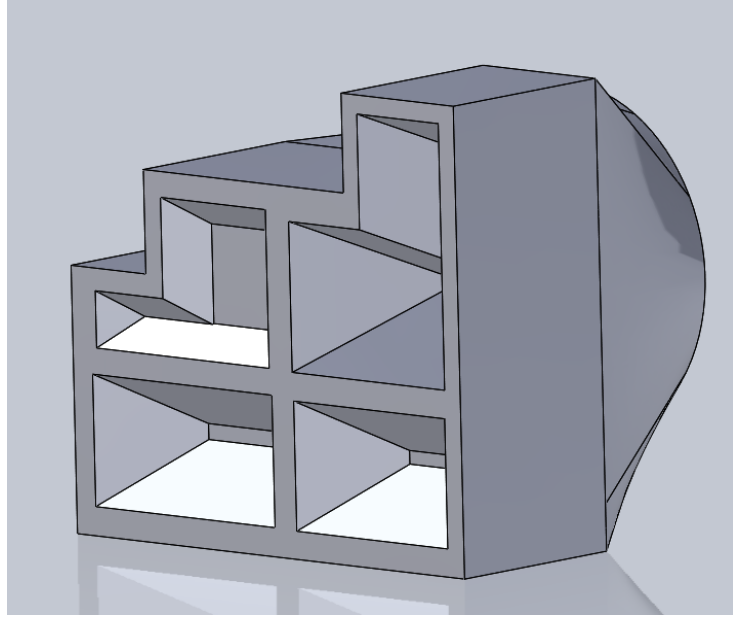

Figure 82 Transition zone

- Adapter

The adapter serves as the entrance to the die and houses the breaker plate and filter element.

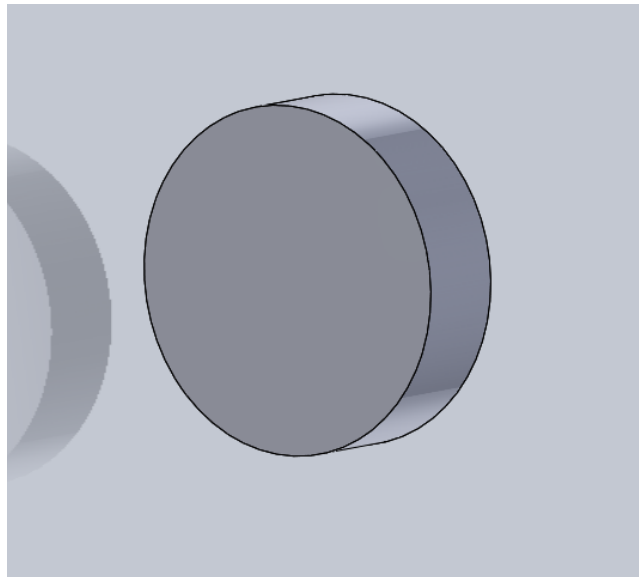

Figure 83 Adapter

An initial CAD model was built by fixing dimensions of the adapter and land. The dimensions of the pre-land section need to be modified to balance the flow at exit of the die. Initially all pre-land sections were assumed to have a thickness of 1mm and the transition zone was designed accordingly. Figure 84 shows the CAD model of the initial extrusion die.

Table 18 defines the boundary conditions for running the flow simulations, and Figure 85 shows the flow simulation results.

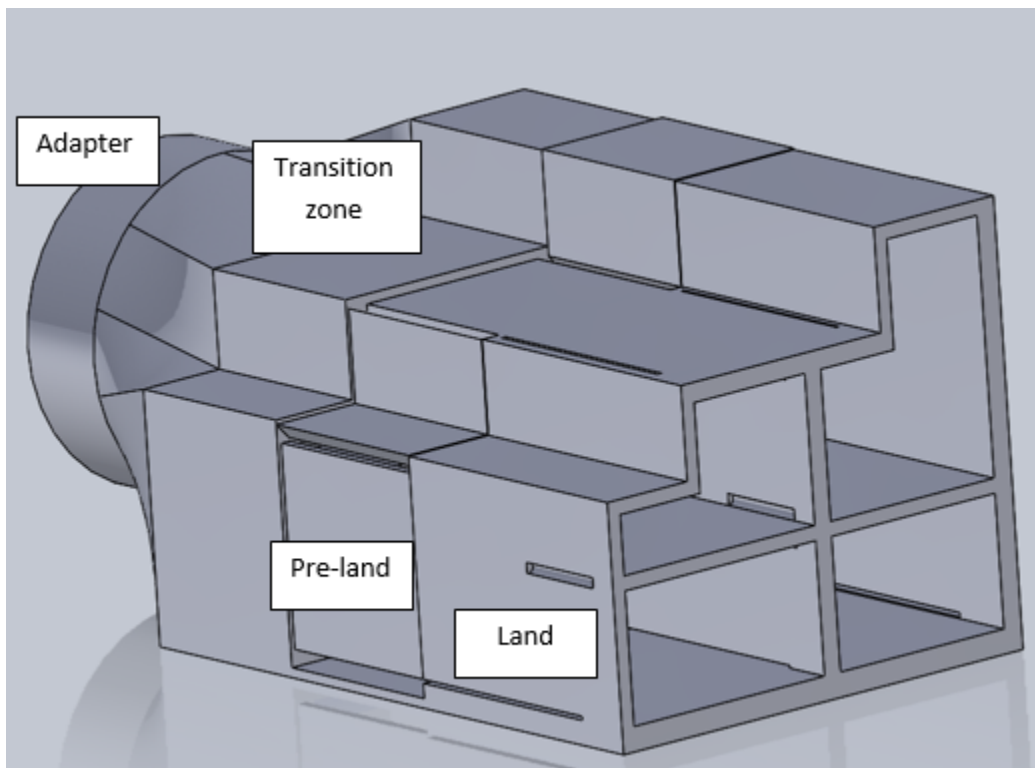

Figure 84 Initial extrusion die

Table 18 Boundary conditions

Parameter	Value
Mesh Size	2mm
Mass flow rate	100 kg/hr.
Inlet temperature	465 K
Primary wall temperature	465 K
Material used	PVC REZ57

As can be seen from the initial flow simulation results (Figure 85), there is a large imbalance in flow with the top sections having maximum flow and the internal walls having much smaller flow.

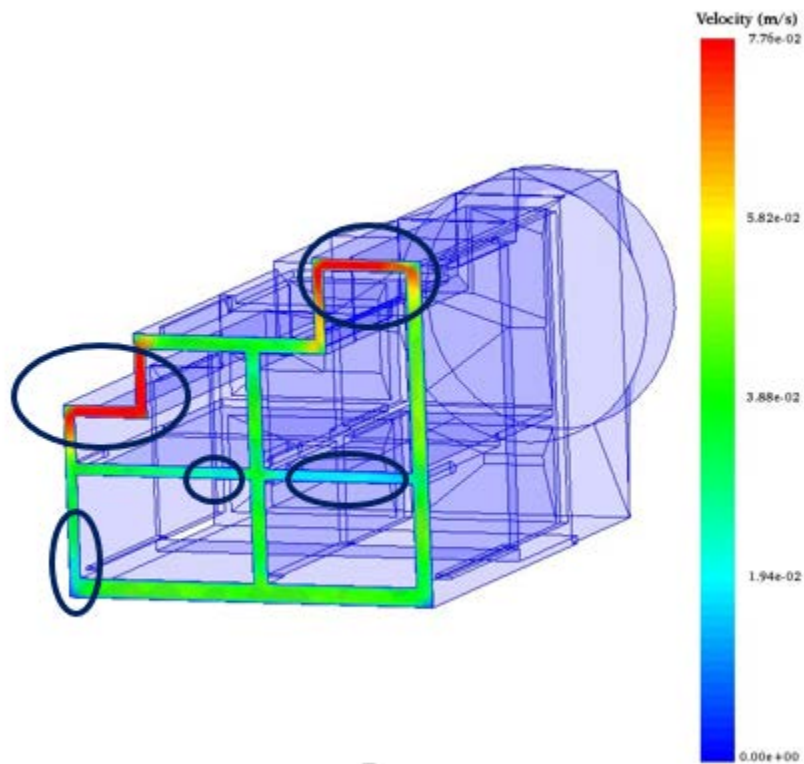

Figure 85 Initial flow simulation results

To balance the flow as per the ACF strategy, the pre-land section dimensions need to be modified.

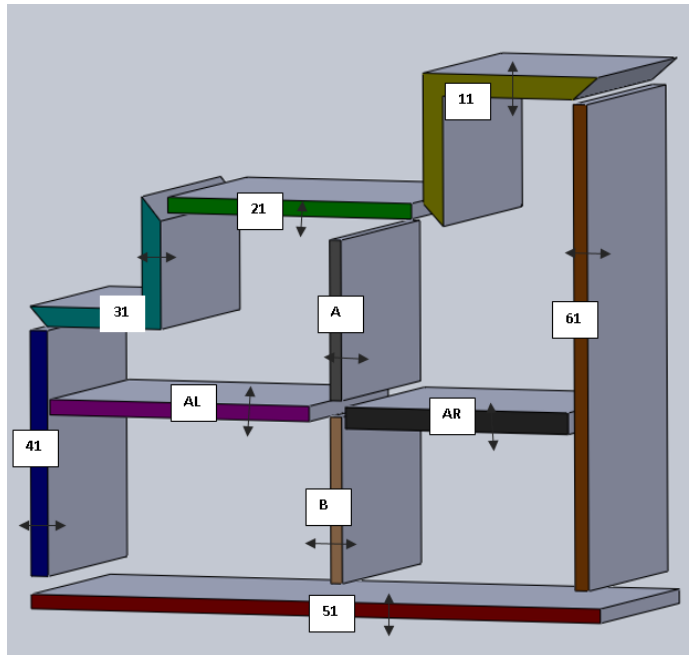

Figure 86 Pre-land section thicknesses

Figure 86 shows different pre-land flow channels whose thickness need to be modified according to the dimensions of the DV they serve (more details in pre-land design section). To obtain the exact values of flow channel thickness, the automatic die optimization algorithm in polyXtrue was employed.

To enable automatic optimization, the thickness of the pre-land flow channels having simple cross-section (21, 41, 51, 61, A, AL, AR, B), and off-set distance (scaling parameter used to increase or decrease the size of features having unique shape) for the pre-land flow channels having complex cross-section (11, 31) was parameterized (refer section 4.2 for parameterization procedure).

After parameterization, the geometry was imported into polyXtrue and the optimization range for the parameterized features was defined. (Table 19)

Table 19 Parameter ranges

Parameter	Min. Value	Max. Value
11 (offset value)	0.1 mm	1 mm
21 thickness	1 mm	2 mm
31 (offset value)	0.1 mm	1 mm
41 thickness	1 mm	3 mm
51 thickness	1 mm	3 mm
61 thickness	1 mm	3 mm
A thickness	1 mm	3 mm
AL thickness	1 mm	3 mm
AR thickness	1 mm	3 mm
B thickness	1 mm	3 mm

After setting the parameter ranges, number of iterations was specified to enable automatic optimization. 40 simulations were run to optimize the 10 parameter values, and it took 3 hr. 25 min. to run the simulations on a Dell Precision T1700 computer. Table 20 shows the parameter values after optimization. Figure 87 shows the flow simulation results.

Table 20 Optimized parameter values

Parameter	Optimized Value
11 (offset value)	0.4 mm
21 thickness	1.3 mm
31 (offset value)	0.15 mm
41 thickness	1.5 mm
51 thickness	1.2 mm
61 thickness	1.2 mm
A thickness	1 mm
AL thickness	1.8 mm
AR thickness	1.28 mm
B thickness	1 mm

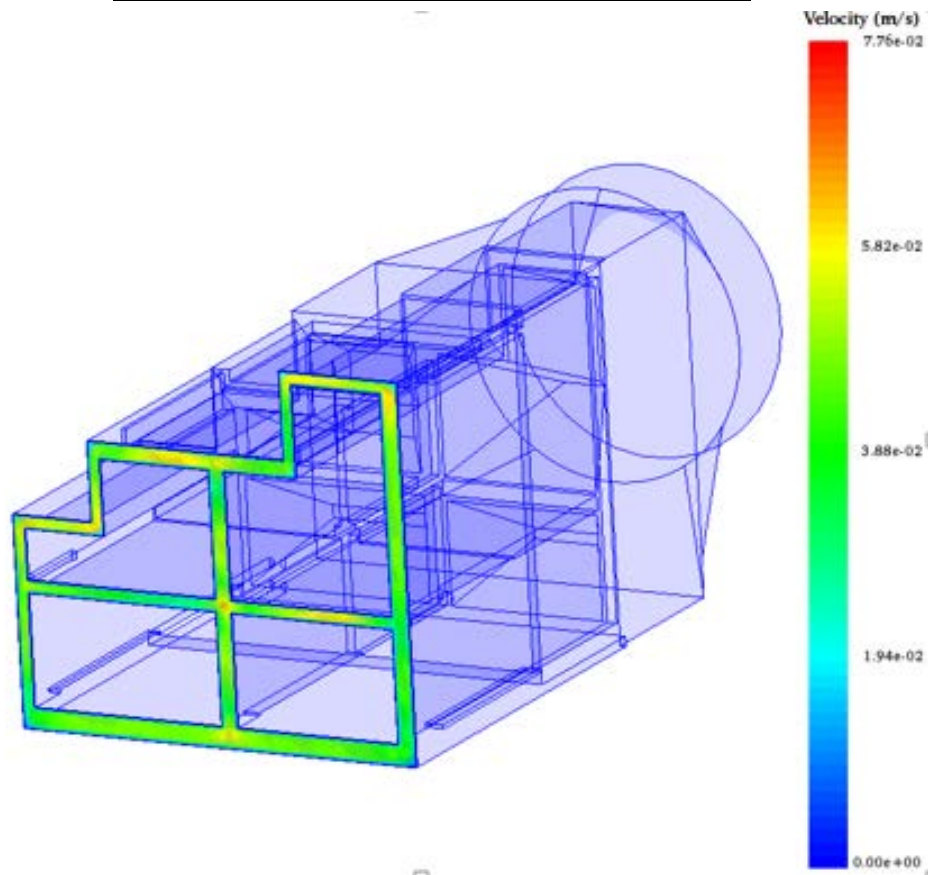

Figure 87 Optimized die flow simulation results

As can be seen from Figure 87, the flow at exit is more balanced. The automatic optimization algorithm could adjust the thickness of pre-land sections such that each DV gets the required percentage of flow and hence resulting in a balanced exit velocity profile.

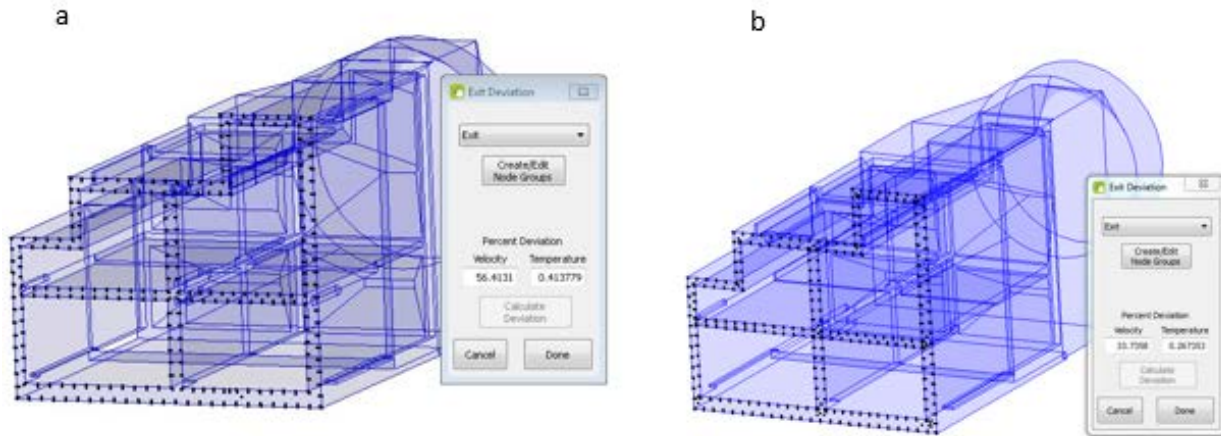

Figure 88 (a) Initial die exit deviation (b) Optimized die exit deviation

Figure 88 (a) and (b) show the reduction in exit velocity deviation from a value of 56.41 for the initial die to 33.73 for the optimized die. Hence the optimization code was successfully applied to optimize the die design while using ACFS.

6.4 Avoid Cross-flow Strategy 2 (Co-extrusion)

In this section the design of a two layer co-extrusion die is optimized.

The profile being co-extruded is the same as described in section 6.3. However, the bottom face of the profile is formed by a layer of two polymers. One layer consists of the polymer entering from the main entrance viz. PVC (REZ57), while the other layer consists of polymer entering from the second exit viz. PVC (Ethyl 7042).

The properties of PVC (REZ57) were discussed in section 3 of this report. The properties of PVC (Ethyl 7042) are shown in Table 21. This polymer uses Cross model (discussed in section 3) for predicting the shear rate dependence of viscosity and Arrhenius model for predicting the temperature dependence of viscosity. The Arrhenius model uses the equation,

$$\eta_0 = A \exp\left(\frac{T_a}{T}\right)$$

Where, η_0 denotes viscosity of polymer at zero shear rate, T_a is a measure of temperature sensitivity of viscosity, A is a material dependent constant, T is the temperature of the polymeric melt (all temperatures are in Kelvin scale).

Table 21 Polymer properties

Parameters	Values
A (Pa.s)	3.21×10^{-11}
T_a (K)	1.49×10^4
τ^* (Pa)	2.65×10^5
n	2.39×10^{-1}
Thermal conductivity k (W/m.K)	1.8×10^{-1}
Melt density ρ (kg/m ³)	1.32×10^3
Specific heat C_p (J/kg.K)	1.8×10^3

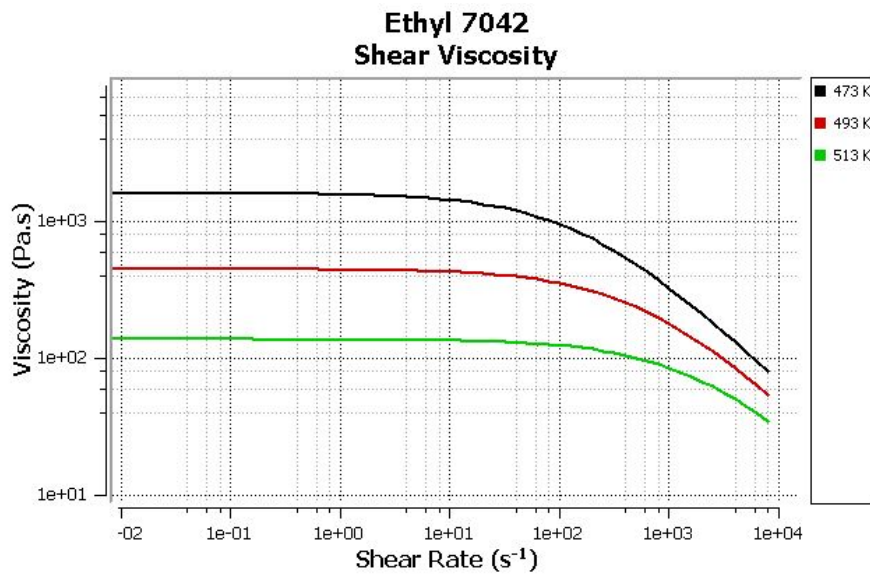

Figure 89 Polymer viscosity graph

Figure 90 shows an initial CAD model of the co-extrusion die.

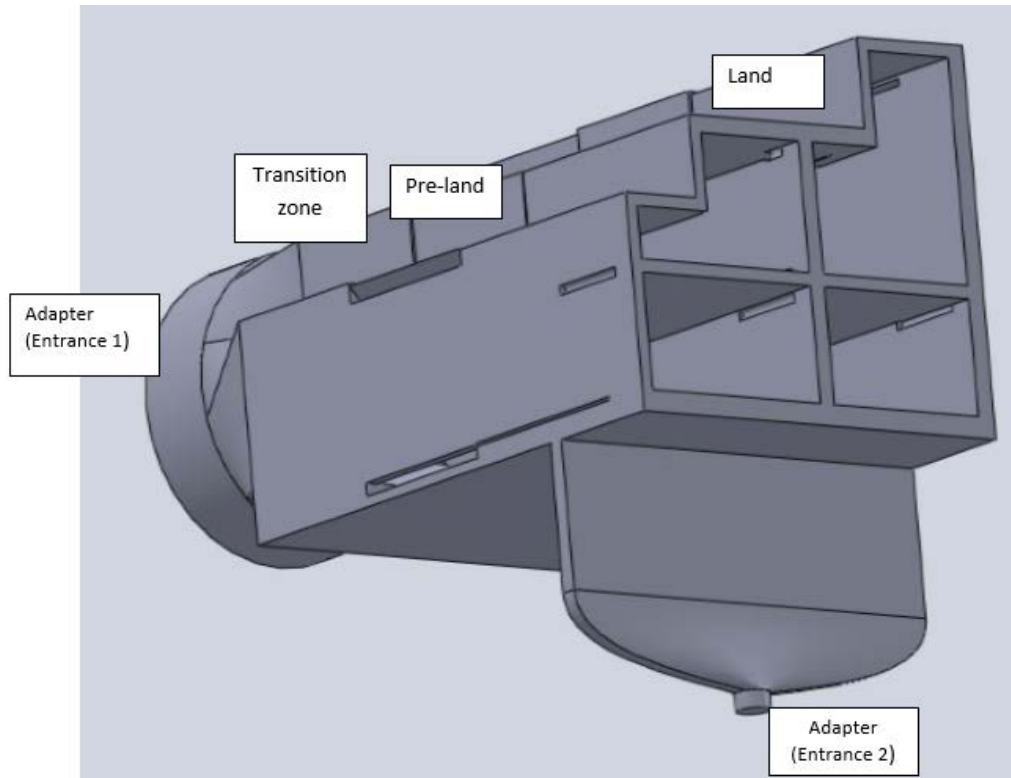

Figure 90 Initial CAD model of co-extrusion die

In the bottom section “51” of the die (refer Figure 79), the polymer coming from entrance 2 forms a layer on top of the polymer coming from entrance 1. The thickness of this second polymer layer is determined by the mass flow rate of the polymer coming from entrance 2. In any case, the velocity of the combined flow is expected to be larger in this portion of the exit face and hence cause an imbalance in the exit velocity profile of the die. A flow simulation was run to verify this assumption.

Table 22 defines the boundary conditions for running the flow simulation.

Table 22 Boundary conditions

Parameter	Value
Mesh Size (maximum)	2 mm
Mesh size (minimum)	0.5 mm
Mass flow rate 1	100 kg/hr.
Mass flow rate 2	20 kg/hr.
Inlet temperature 1	465 K
Inlet temperature 2	465 K
Primary wall temperature	465 K

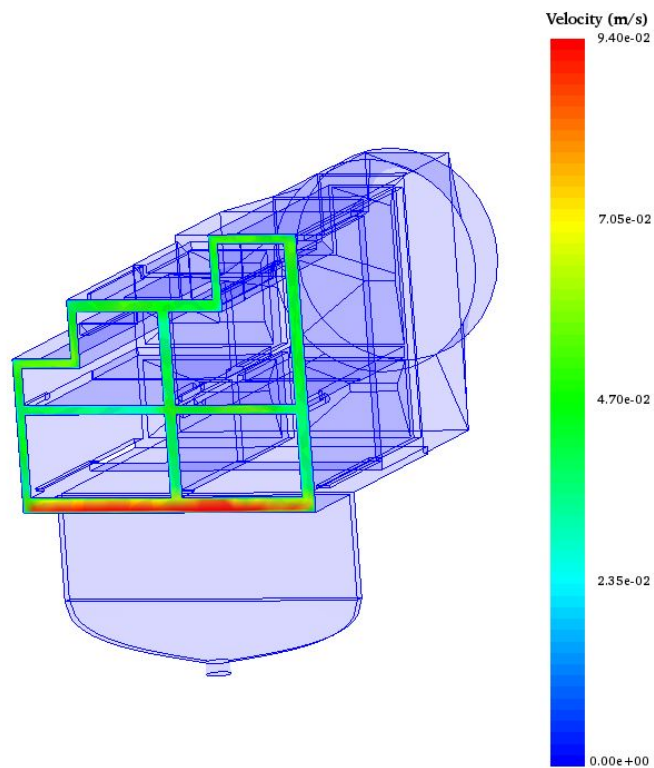

Figure 91 Initial flow simulation result

As can be seen from Figure 91, the bottom section of the profile receives a high concentration of flow due to the polymer coming from entrance 2 of the die. Depending on the desired layer thickness the velocity of the polymer from entrance 2 is fixed. Hence to balance the flow it is proposed to re-size the pre land channel feeding the bottom section of the profile (refer Figure 92).

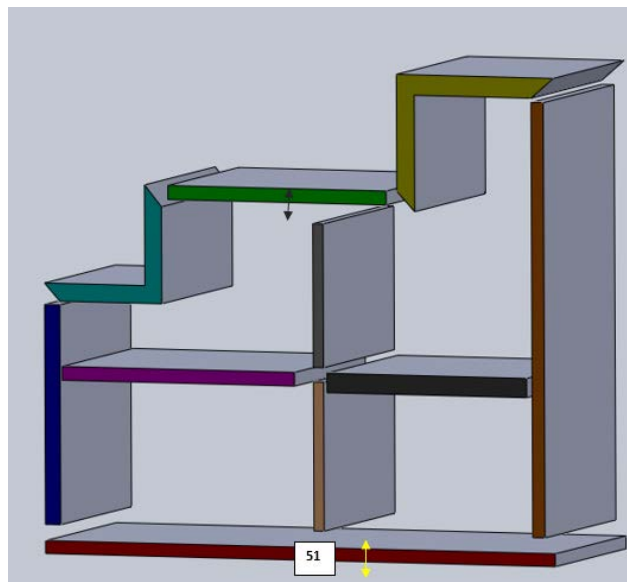

Figure 92 Pre-land channel modification to balance exit velocity

The automatic optimization algorithm in polyXtrue was employed to find the optimum thickness of channel 51. As was previously done in section 6.3, the parameterized geometry having section 51 thickness of 1.2 mm, was imported into Solidworks and the parameter range was specified. In this case the parameter range specified was thickness of channel 51, which ranged between 0.5 to 1 mm.

Five simulations were run to optimize the thickness of channel 51, and it took 25 min. to run the simulations on a Dell Precision T1700 computer.

Post optimization it was found that the optimum thickness for section 51 was 0.8 mm. Figure 93 shows the flow simulation results.

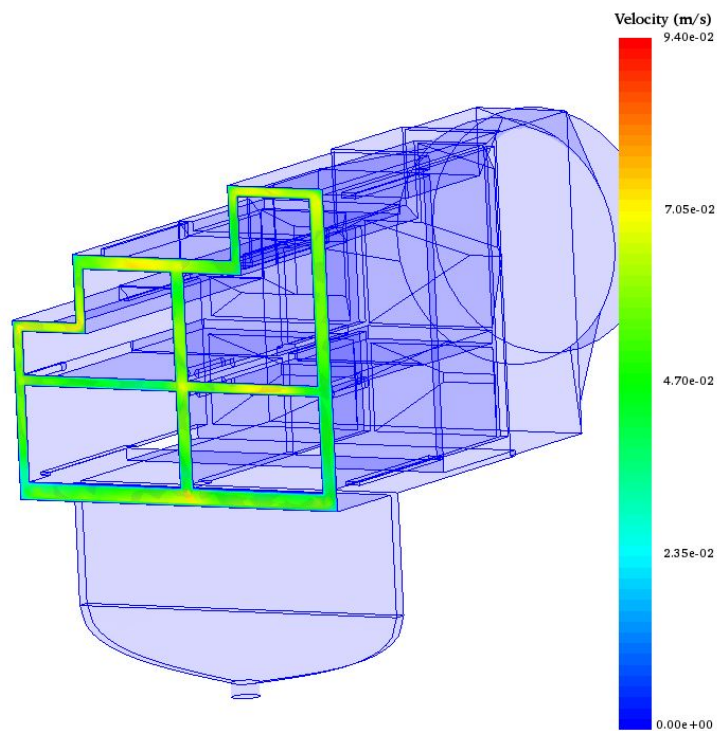

Figure 93 Optimized die flow simulation results

As can be seen from Figure 93, the exit velocity is now balanced. The optimization code was able to reduce the thickness of section 51 such that combined flow velocity of polymers 1 and 2 was close to the average global flow velocity at the exit face.

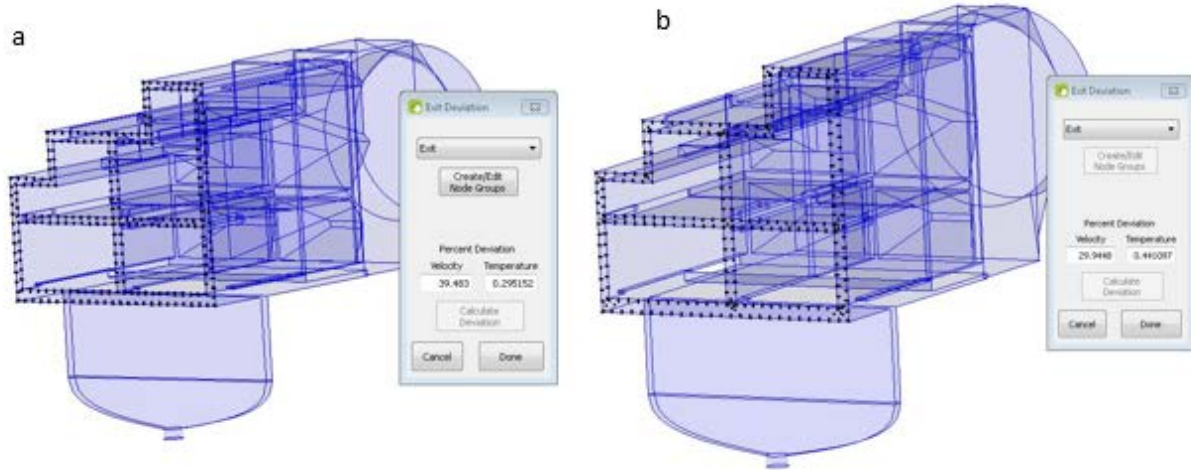
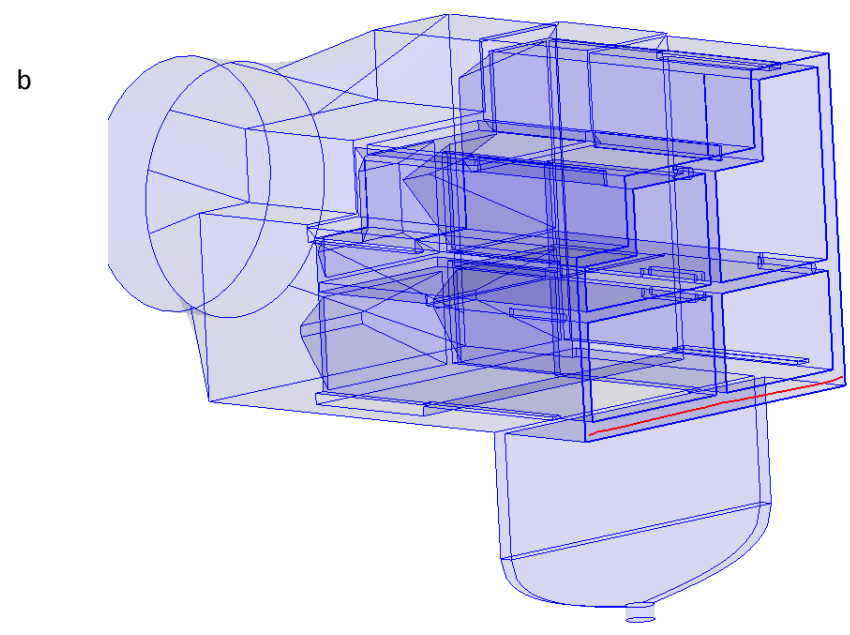
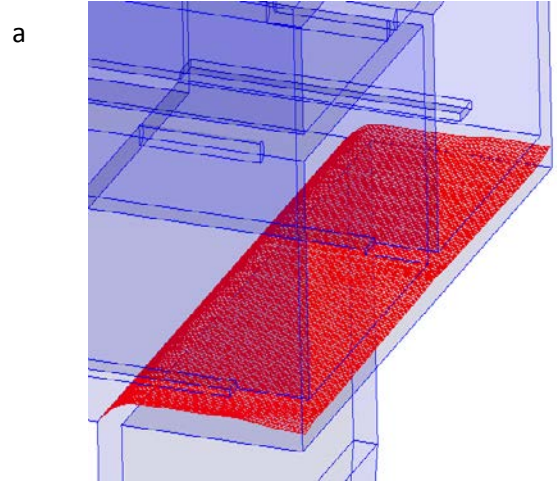

Figure 94 (a) Initial die exit deviation (b) Optimized die exit deviation

Figure 94 (a) and (b) show the reduction in exit velocity deviation from a value of 39.48 for the initial die to 29.94 for the optimized die.

The other important aspect to be considered while designing dies for co-extrusion is the shape of the layer where the two polymers interface. As can be seen from Figure 95 (a), (b) the interface layer for the initial die is slightly curved, whereas the interface layer for the modified die has segments where it is a straight line but is skewed at the T-junctions in the middle and at the extreme ends.



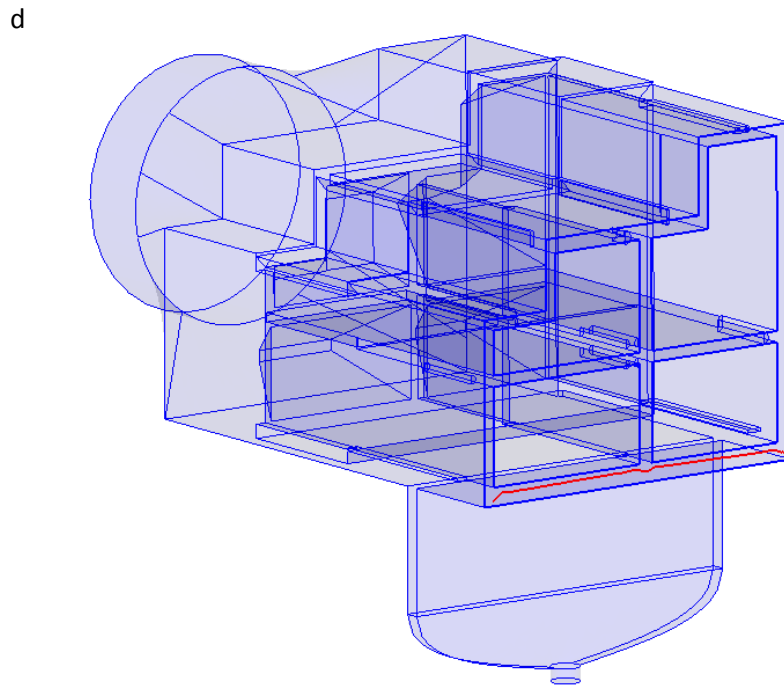
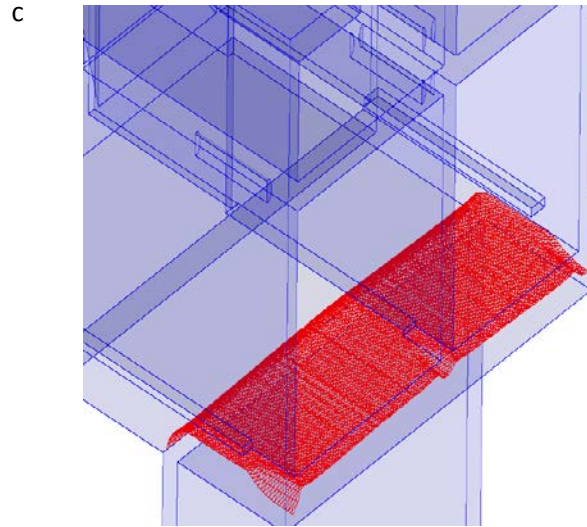

Figure 95 (a), (b) layer structure for initial die (c), (d) layer structure for final die

Hence, a co-extrusion die was designed using the avoid cross-flow strategy, and its dimensions were optimized using the automatic die optimization algorithm in polyXtrue to obtain a uniform velocity distribution at the exit face of the die.

7. Summary and Recommendation

7.1 Conclusions

- In this work different extruded profile shapes were considered, and the application of unique design features was discussed to balance the flow at the exit face of the die.
- Five different possibilities were considered for changing the land length locally of various sections of the profile, and the other six features included the insertion of dams, slits, pre-land flow separators, corner projections, drafting channels and entrance channel design for co-extrusion dies.
- Significant improvements in exit deviation was used to quantify the improvement in flow balance across the die exit.
- The ‘Elemental Sections Method’ and the ‘Avoid Cross-Flow Strategy’ were used to design dies having varying wall thicknesses and the optimization routine in the polyXtrue software was employed to arrive at the final die dimensions.
- Significant reduction in design time and improvement in dimensional accuracy of the final die were demonstrated by the application of the optimization routine in polyXtrue.

7.2 Recommendations

- Currently extrusion die design software's offer an automatic die generation feature which can build a die from bottom up for the given extrudate shape. This feature however is found to be effective only for sheet, annular and simple profile extrusion dies. For complex profile extrusions, it is proposed to develop a routine which can employ the design features described herein, to automatically generate a die and balance it by modifying these design feature dimensions.
- Furthermore, work needs to be done regarding the manufacturability aspect of the design features described herein. A standard document describing how each of these features could be built into the die, would make the design process more efficient.

8. References

- [1] J. M. Nóbrega¹, A. Rajkumar¹, C. Fernandes¹, L.L. Ferrás¹, F. Habla², O. Hinrichsen², J. Guerrero³ and O.S. Carneiro¹, “Using OpenFOAM® to Aid the Design of Extrusion Dies for Thermoplastics Profiles”, 9th Open FOAM Workshop, 23-26 June 2014, Zagreb, CROATIA
- [2] Lecture notes, MEEM 4635 “Design with plastics”, Michigan Technological University, Houghton, Michigan.
- [3] J.M. Nobrega and O.S. Canerio, “Design of Extrusion Forming Tools”, Smithers Rapra Technology Ltd., 2012.
- [4] JFT Pittman, “Computer-aided design and optimization of profile extrusion dies for thermoplastics and rubber: a review”, Proceedings of the Institution of Mechanical Engineers, Part E: Journal of Process Mechanical Engineering, Vol. 225, 2011.
- [5] Y. Sun and M. Gupta, “Effect of Elongational Viscosity on the Flow in a Flat Die”, International Polymer Processing 18, 356 (2003)
- [6] Mahesh Gupta, “Automatic Optimization of Extrusion Dies “, Plastic Flow LLC.
- [7] J.M. Nobrega, O.S. Canerio, P.J. Oliveira, F.T. Pinho, “Flow Balancing in Extrusion Dies for Thermoplastic Profiles”, International Polymer Processing 18, (2003)
- [8] Koziey, B. L., Vlachopoulos, J., Vlcek, J. and Svabic, J., “Profile die design by pressure balancing and cross flow minimization”. In Proceedings of ANTEC 1996, Indianapolis, Indiana, 5-9 May 1996, pp. 247–252.
- [9] C.M. Lee, D.Y. Yang, “A three-dimensional steady-state finite element analysis of square die extrusion by using automatic mesh generation”, International Journal of Machine Tools & Manufacture 40, 33-47 (2000).