



**Michigan
Technological
University**

Michigan Technological University
Digital Commons @ Michigan Tech

[Michigan Tech Patents](#)

Vice President for Research Office

7-31-2012

NOx control systems and methods for controlling NOx emissions

Maruthi Devarakonda

Gordon Parker

Michigan Technological University, ggparker@mtu.edu

John Johnson

Michigan Technological University, jjohnson@mtu.edu

Follow this and additional works at: <https://digitalcommons.mtu.edu/patents>

 Part of the [Engineering Commons](#)

Recommended Citation

Devarakonda, Maruthi; Parker, Gordon; and Johnson, John, "NOx control systems and methods for controlling NOx emissions" (2012). *Michigan Tech Patents*. 116.

<https://digitalcommons.mtu.edu/patents/116>

Follow this and additional works at: <https://digitalcommons.mtu.edu/patents>

 Part of the [Engineering Commons](#)



(12) **United States Patent**
Devarakonda et al.

(10) **Patent No.:** **US 8,230,677 B2**
(45) **Date of Patent:** **Jul. 31, 2012**

(54) **NO_x CONTROL SYSTEMS AND METHODS FOR CONTROLLING NO_x EMISSIONS**

(75) Inventors: **Maruthi Devarakonda**, Richland, WA (US); **Gordon Parker**, Houghton, MI (US); **John Johnson**, Houghton, MI (US)

(73) Assignee: **Michigan Technological University**, Houghton, MI (US)

(*) Notice: Subject to any disclaimer, the term of this patent is extended or adjusted under 35 U.S.C. 154(b) by 909 days.

(21) Appl. No.: **12/324,533**

(22) Filed: **Nov. 26, 2008**

(65) **Prior Publication Data**

US 2009/0133384 A1 May 28, 2009

Related U.S. Application Data

(60) Provisional application No. 60/990,211, filed on Nov. 26, 2007, provisional application No. 61/052,759, filed on May 13, 2008.

(51) **Int. Cl.**
F01N 3/00 (2006.01)

(52) **U.S. Cl.** **60/286; 60/276; 60/295; 60/301**

(58) **Field of Classification Search** **60/276, 60/286, 282, 274, 301**

See application file for complete search history.

(56) **References Cited**

U.S. PATENT DOCUMENTS

6,701,707 B1 * 3/2004 Upadhyay et al. 60/277
7,093,427 B2 8/2006 Van Nieuwstadt et al.
7,134,273 B2 * 11/2006 Mazur et al. 60/286

7,178,328 B2 * 2/2007 Solbrig 60/286
7,272,924 B2 9/2007 Itoh et al.
2002/0148220 A1 10/2002 Patchett et al.
2003/0213234 A1 11/2003 Funk et al.
2004/0098968 A1 5/2004 Van Nieuwstadt et al.
2004/0128982 A1 * 7/2004 Patchett et al. 60/274
2005/0129601 A1 * 6/2005 Li et al. 423/239.2
2007/0119153 A1 * 5/2007 Pierz et al. 60/286
2007/0137181 A1 6/2007 Upadhyay et al.

FOREIGN PATENT DOCUMENTS

WO 2009/070734 6/2009

OTHER PUBLICATIONS

International Preliminary Report on Patentability for Application No. PCT/US08/84980 dated Jan. 28, 2010 (7 pages).

Moos, "Selective ammonia exhaust gas sensor for automotive applications," Sensors and Actuators B (2002) 83:181-189.

Upadhyay, D. et al., "Model based analysis and control design of a urea-SCR deNO_x aftertreatment system," ASME Journal of Dynamic Systems, Measurement and Control (2006) 128:737-741.

Wang, D.Y., "Ammonia sensor for SCR NO_x reduction," Diesel Engine-Efficiency and Emissions Research • (DEER) conference presentation, Detroit, Michigan (Aug. 13-16, 2007) 1-20.

International Search Report and Written Opinion of Application No. PCT/US2008/084980 dated Jan. 29, 2009 (6 pages).

* cited by examiner

Primary Examiner — Thomas Denion

Assistant Examiner — Jesse Bogue

(74) *Attorney, Agent, or Firm* — Michael Best & Friedrich LLP

(57) **ABSTRACT**

An exhaust aftertreatment system comprising a selective reduction catalyst, a NO_x sensor or an NH₃ sensor, a urea injector, and a dosing control unit, wherein the dosing control unit calculates the rate of urea injection by estimating the concentrations of NO and NO₂ in the exhaust downstream of the SCR catalyst.

11 Claims, 10 Drawing Sheets

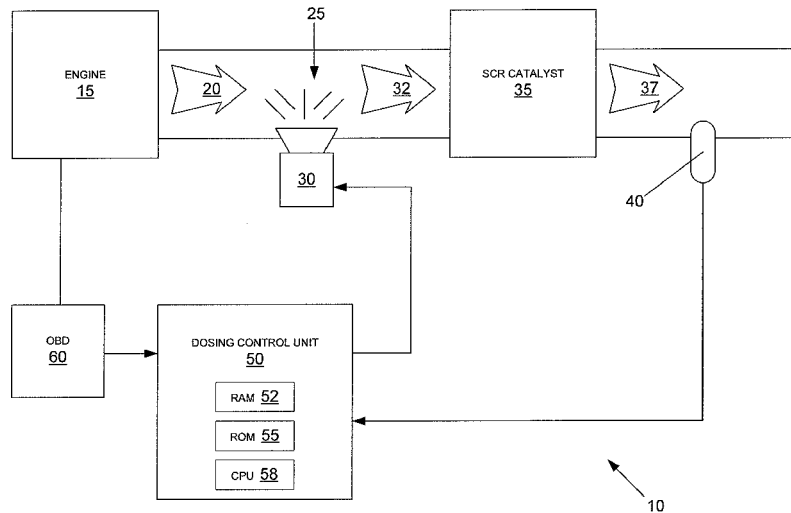

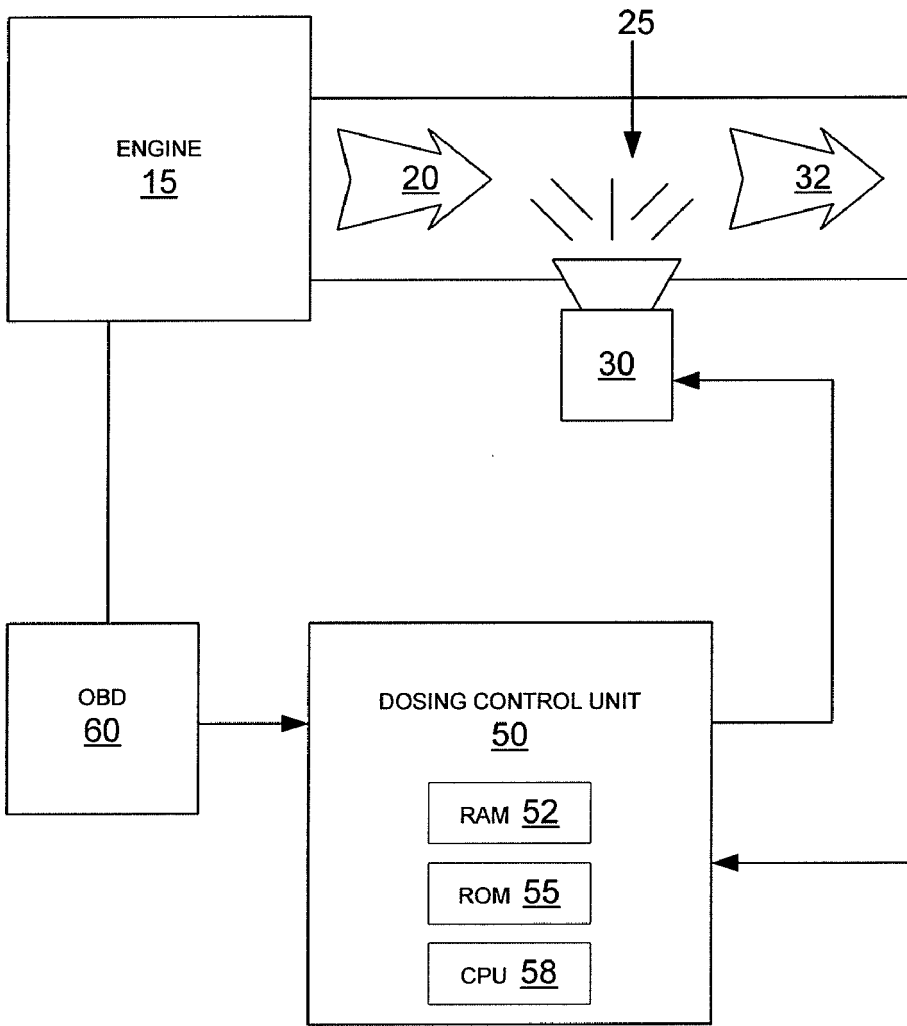
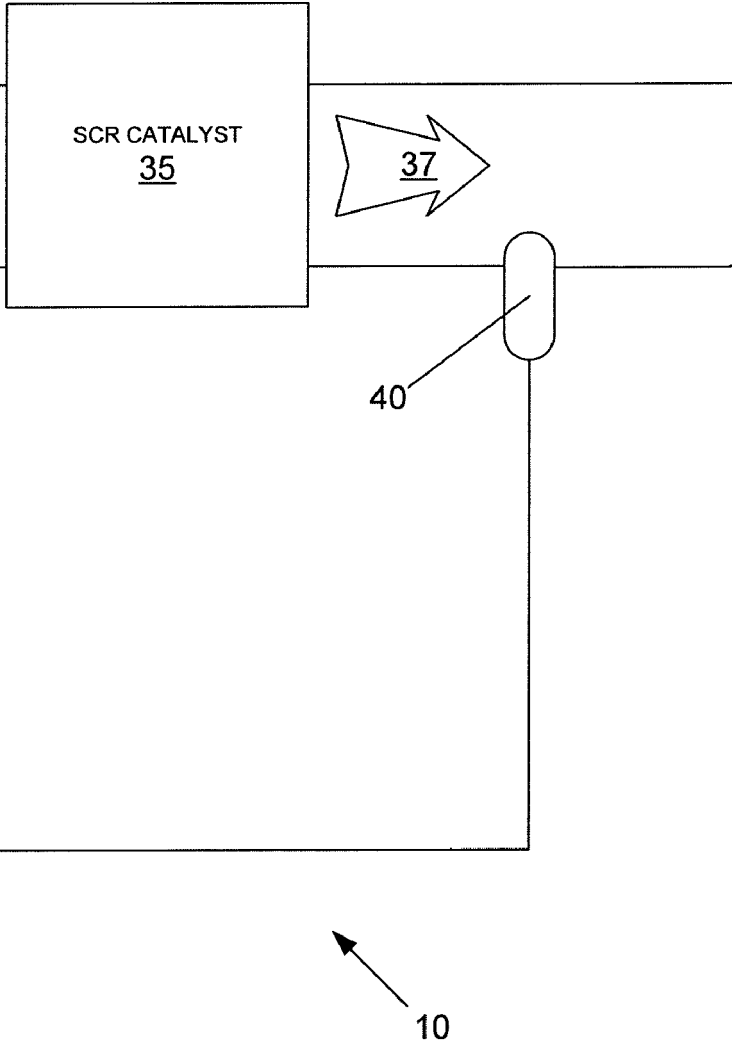
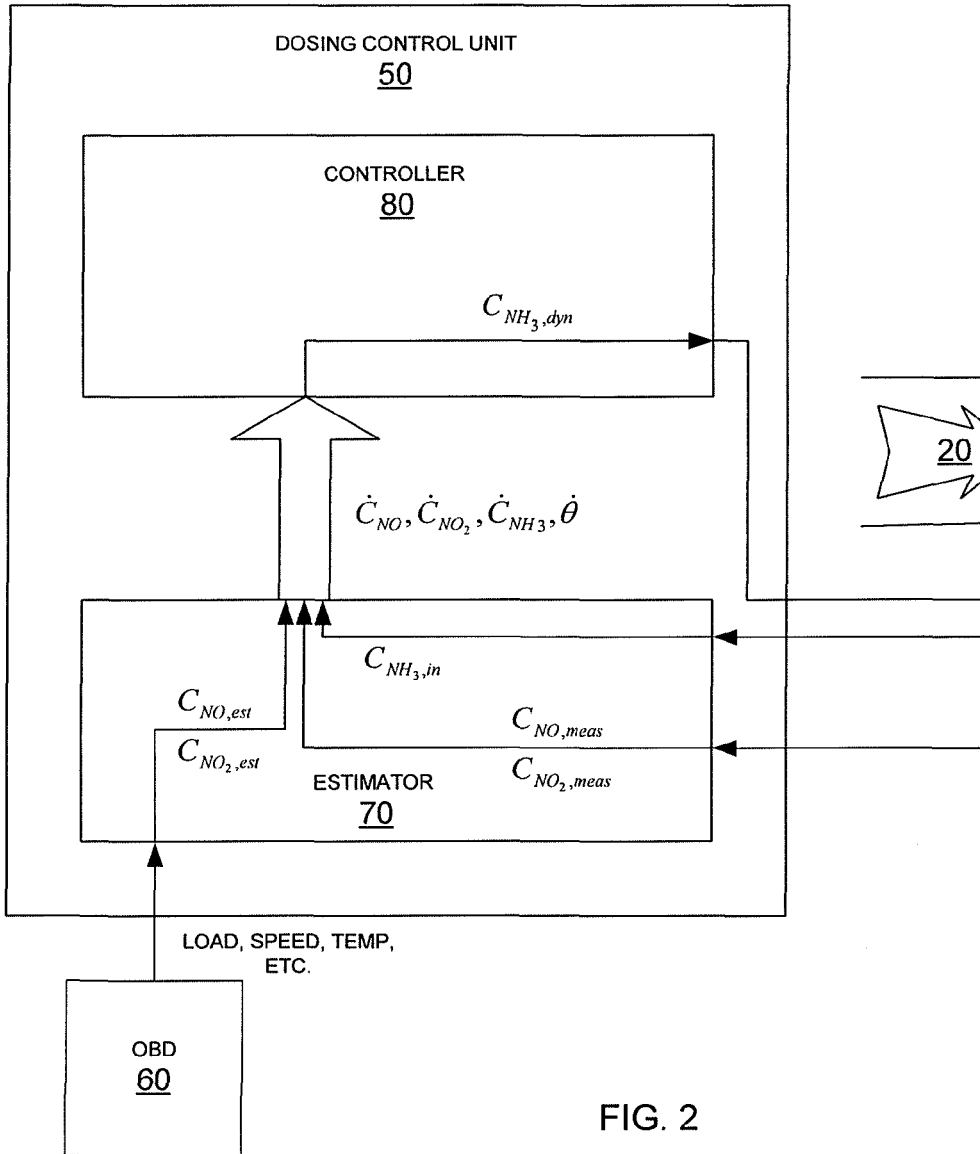
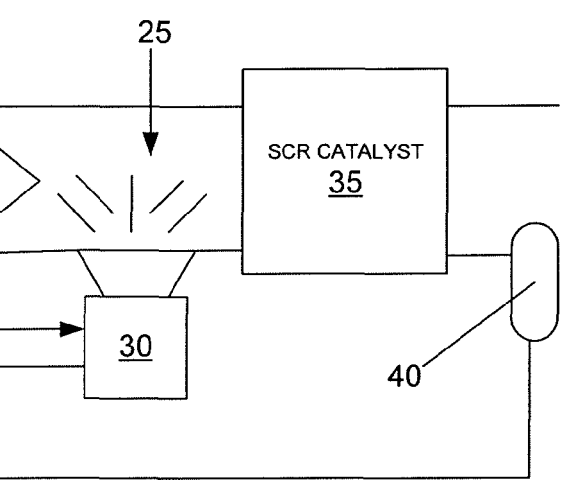

FIG. 1







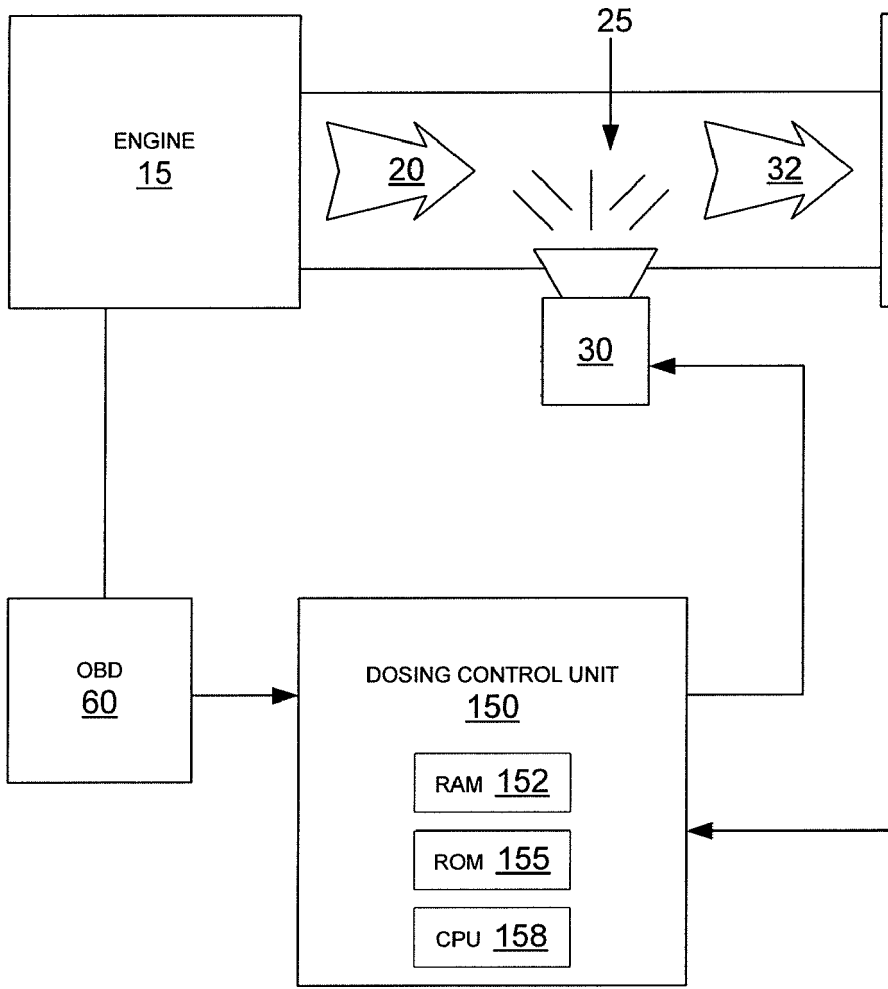
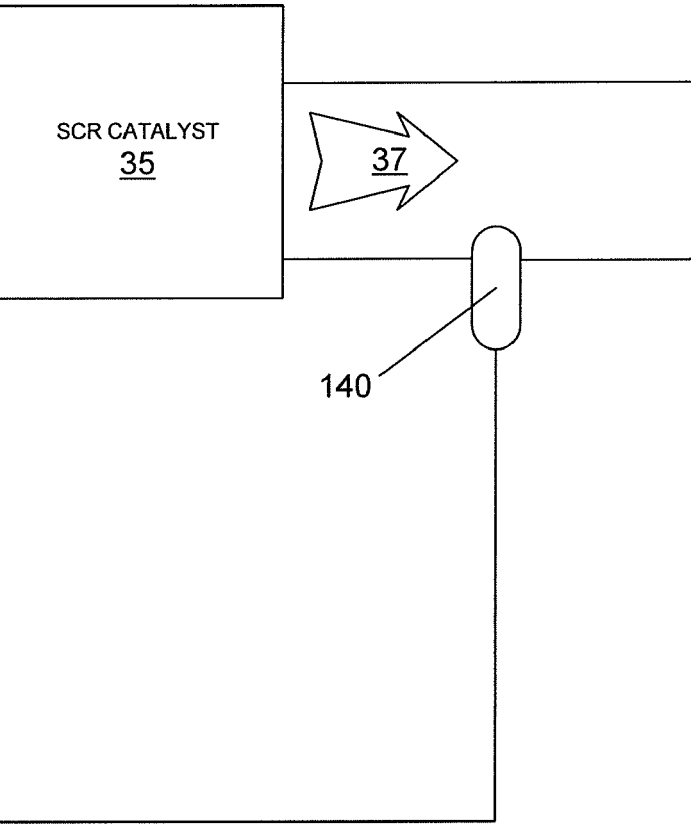

FIG. 3



110

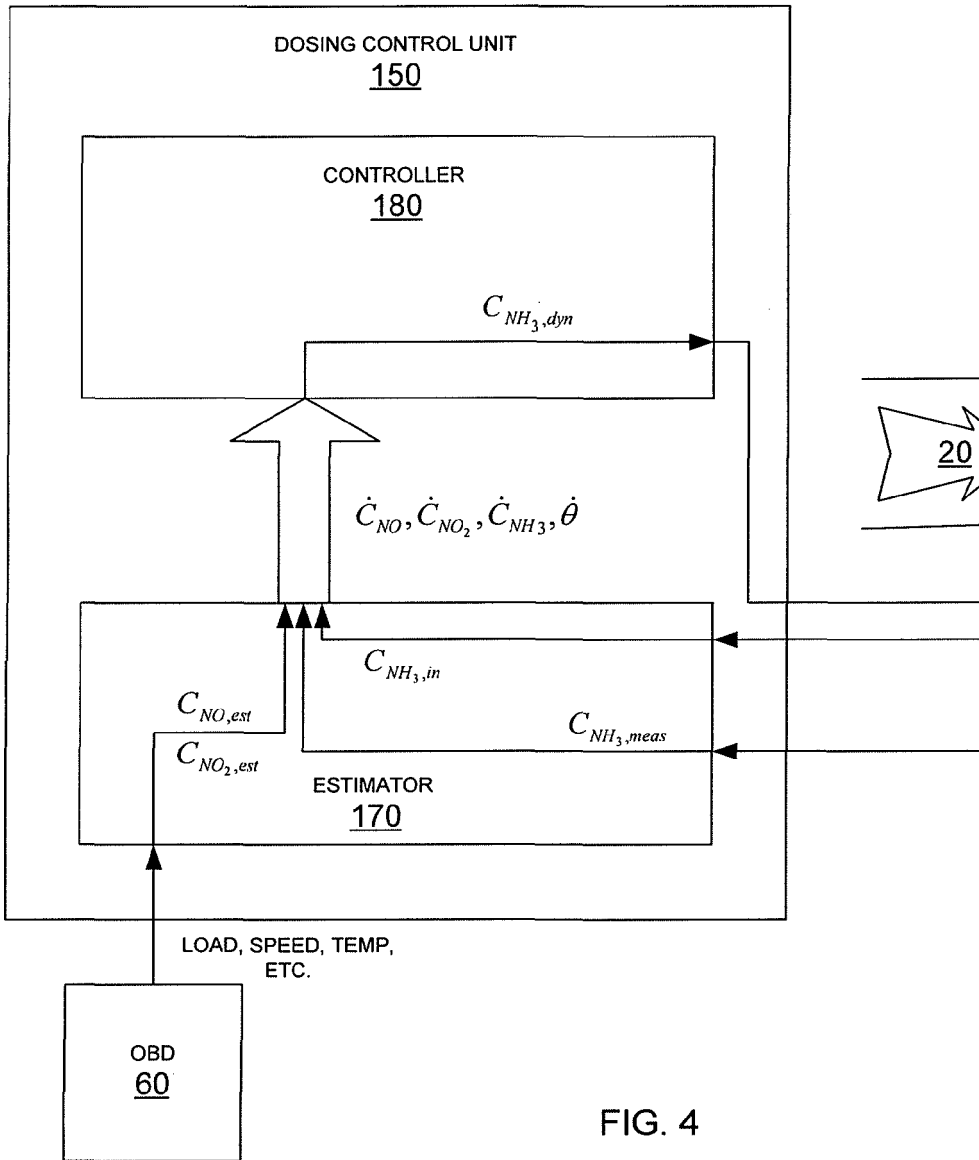
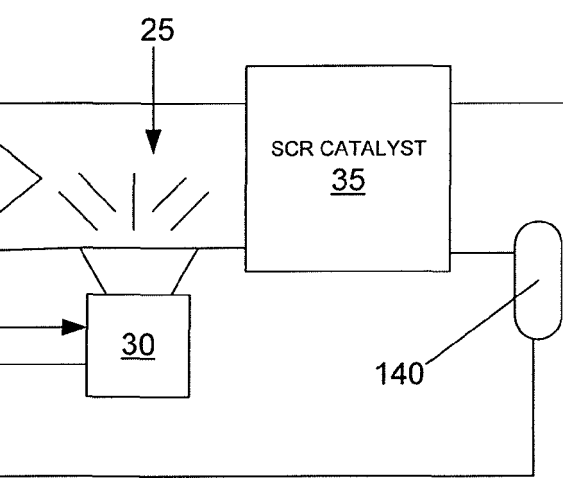

FIG. 4



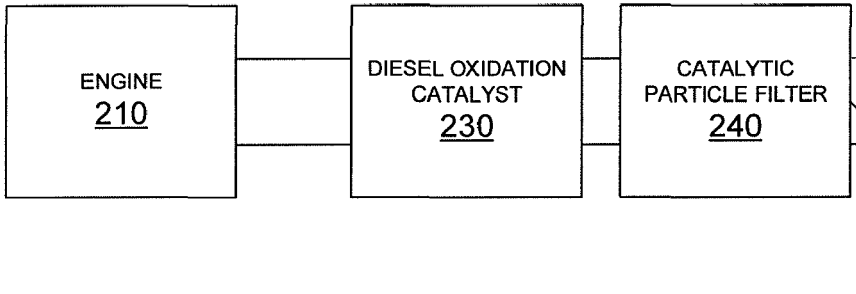
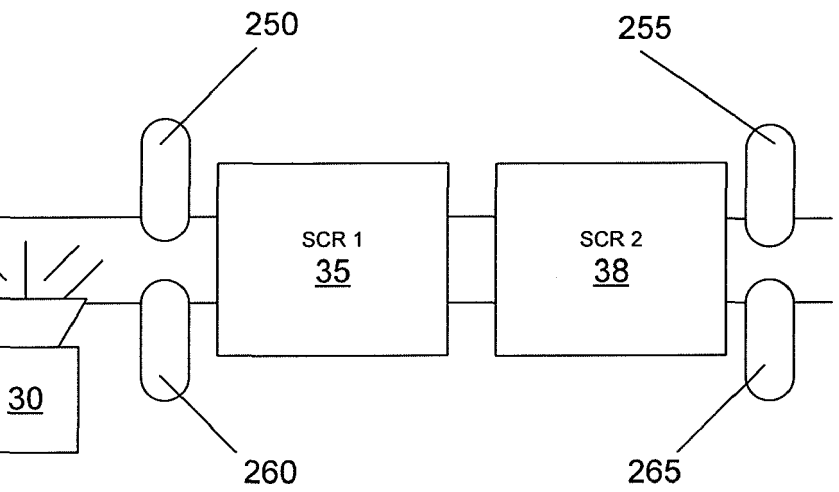

FIG. 5



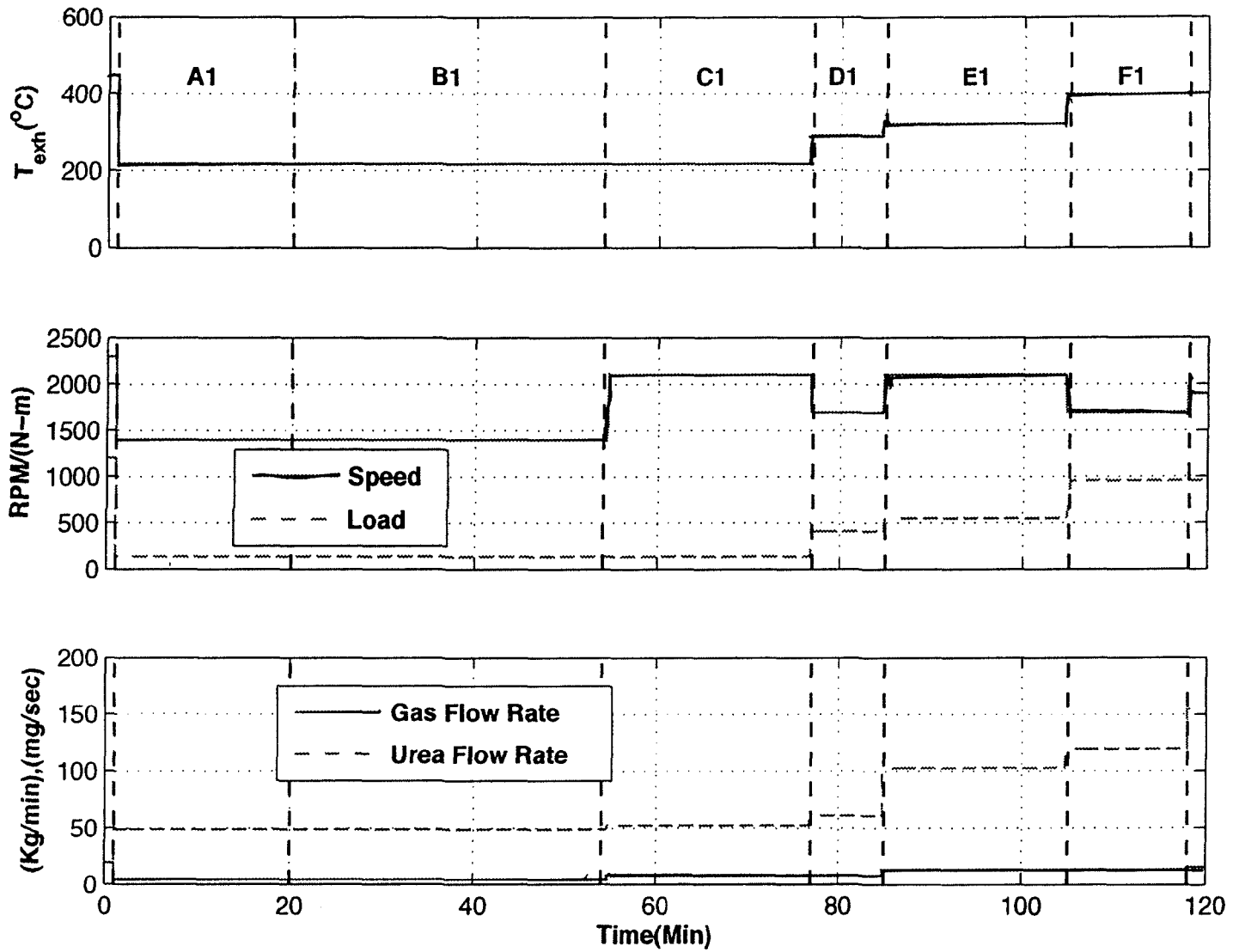

FIG. 6

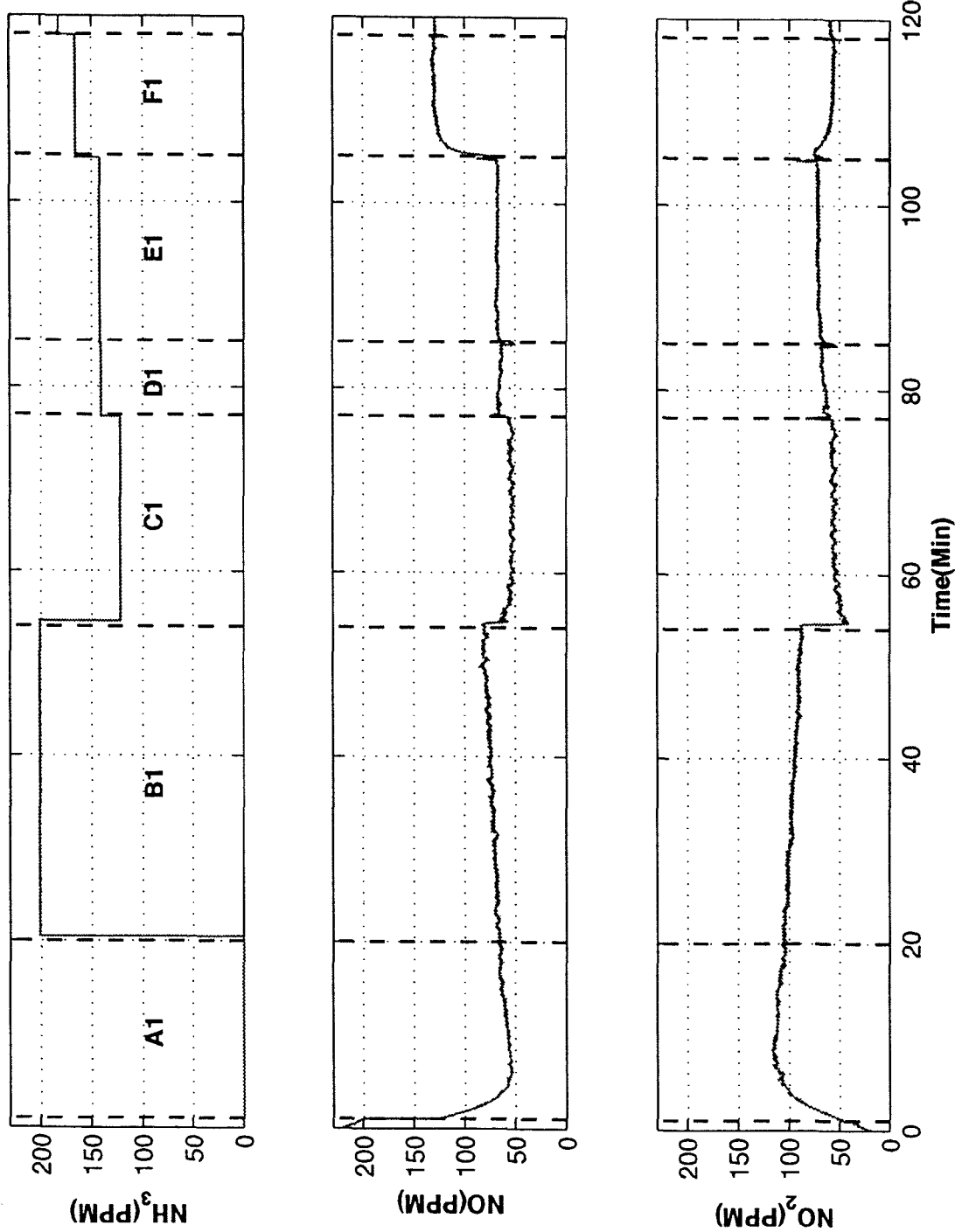

FIG. 7

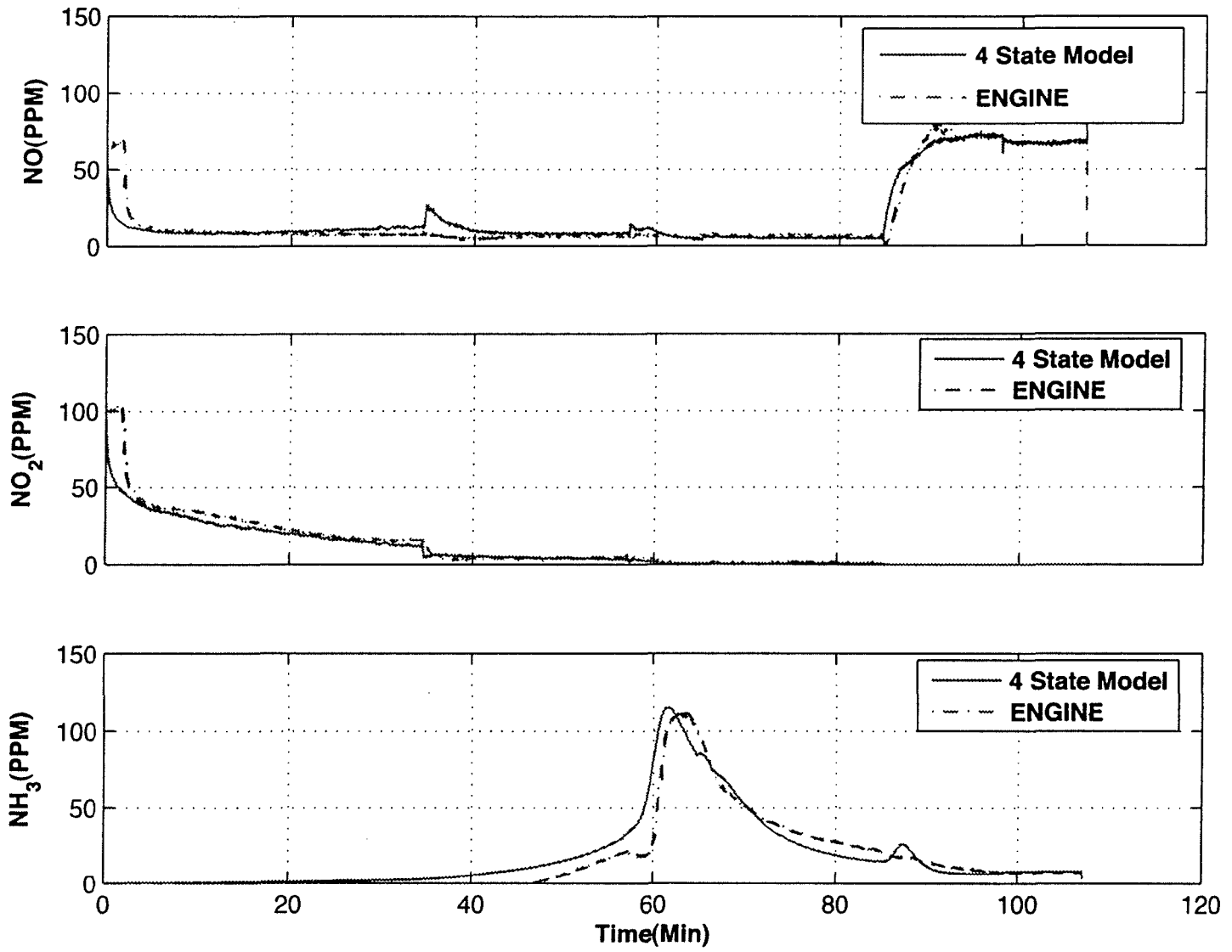

FIG. 8

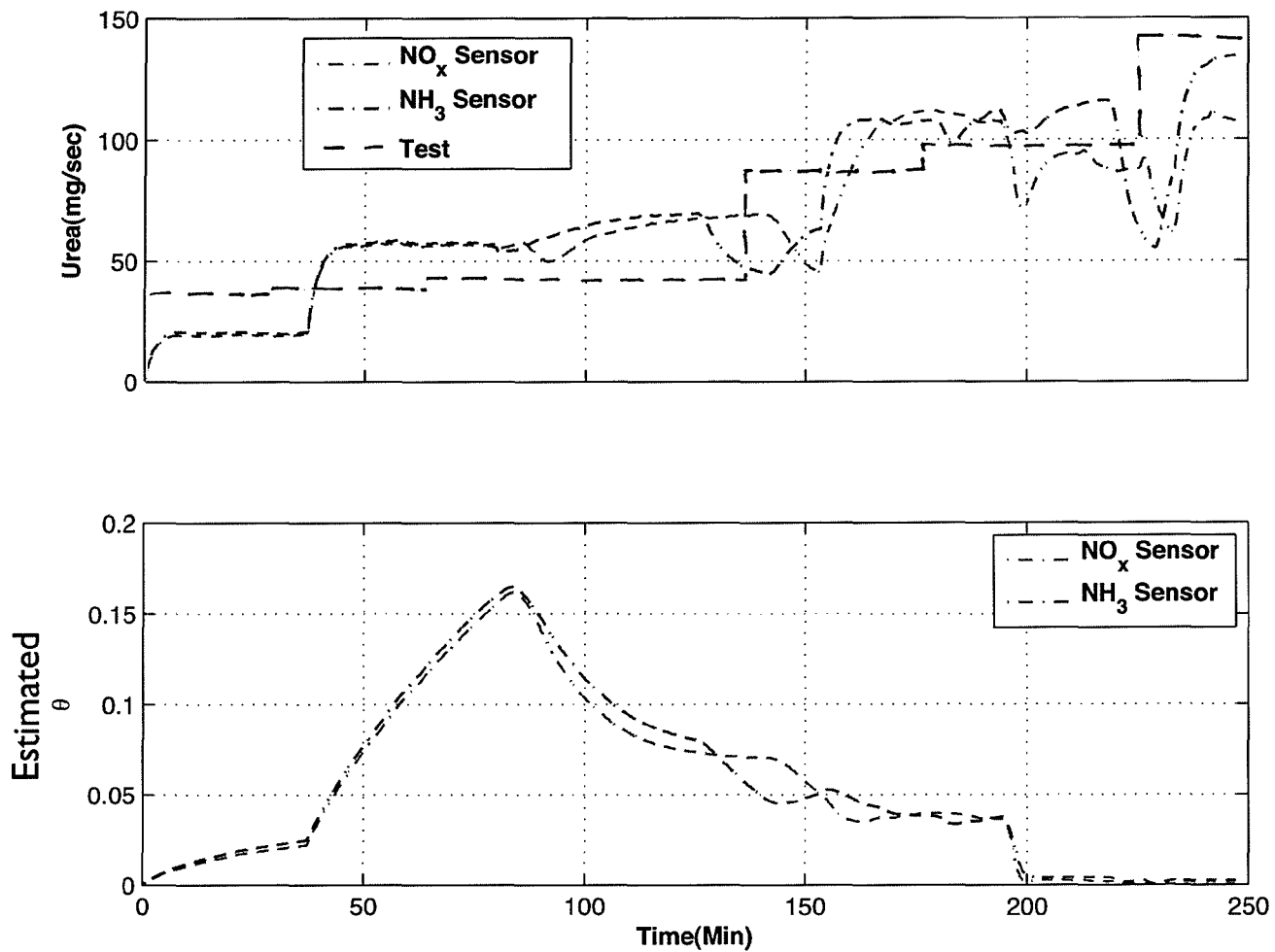

FIG. 9

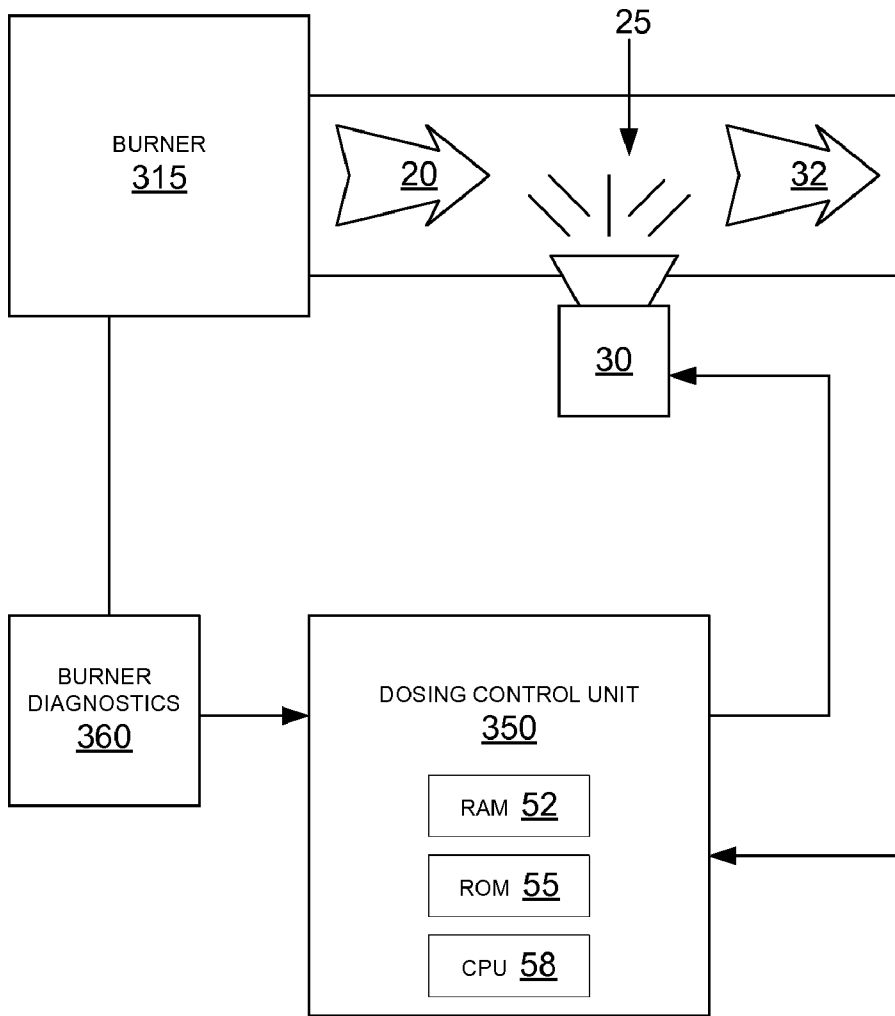
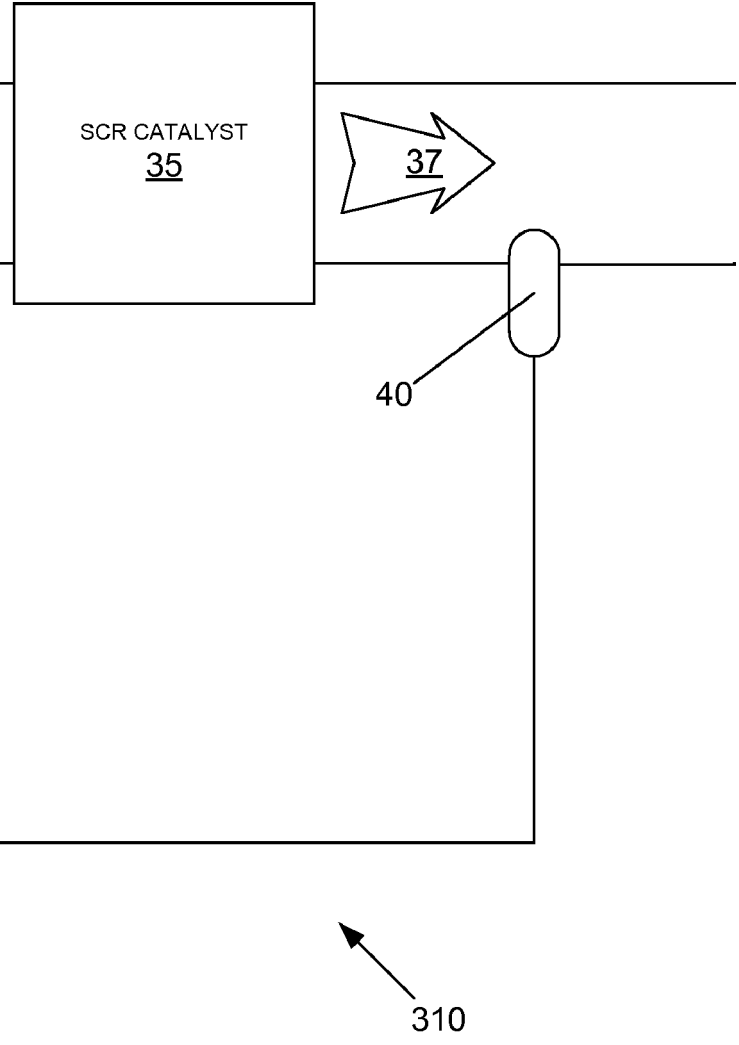

FIG. 10



1

NO_x CONTROL SYSTEMS AND METHODS FOR CONTROLLING NO_x EMISSIONS

CROSS-REFERENCE TO RELATED APPLICATIONS

This application claims priority to U.S. Provisional Patent Applications Ser. Nos. 60/990,211, filed Nov. 26, 2007, and 61/052,759, filed May 13, 2008, both of which are incorporated herein by reference in their entirety.

FIELD OF INVENTION

The present invention relates to methods for reducing nitrogen oxide emissions from combustion processes. In particular, the invention relates to the use of catalysts in combination with an ammonia-precursor injector to reduce nitrogen oxide emissions from engines, such as those used by diesel-powered vehicles, equipment, and generators.

BACKGROUND

Nitrogen oxides (NO_x) are a well-known class of atmospheric pollutants that pose risks to human health, agriculture, and property. Nitrogen oxides are key ingredients in the formation of photochemical smog, which damages respiratory functions and limits visibility. Additionally, nitrogen oxides form nitric acid when they react with moisture in the atmosphere, thus forming acid rain. They are also involved in the production of tropospheric ozone. Environmental agencies around the world have instituted standards for nitrogen oxide control in an effort to reduce nitrogen oxides' harmful effects.

Nitrogen oxides broadly include compounds such as NO₃ and N₂O₅, but the bulk of atmospheric nitrogen oxides are N₂O, NO and NO₂. When dealing with reactive atmospheric nitrogen, it is often sufficient to deal only with NO and NO₂. (See Seinfeld and Pandis, *Atmospheric Chemistry and Physics*.)

While there are some natural sources of NO_x, most of the NO_x in urban environments is a by-product of fossil-fuel combustion. At temperatures found in engines, free-radical chemistry converts atmospheric nitrogen into nitrogen oxides. In particular, lean burning internal combustion engines, such as those used in diesel-powered vehicles, may produce NO_x at a many parts-per-million level. While combustion processes typically produce more NO than NO₂, the two easily interconvert in the presence of oxygen species. Thus, an effective emission control systems must account for both species. Additionally, NO₂-producing processes present a greater health risk than NO-producing processes, as is reported in the literature.

In view of the health risks posed by atmospheric NO_x, the U.S. Environmental Protection Agency regulates acceptable levels of NO_x emissions for U.S. cars and trucks.

SUMMARY OF THE INVENTION

In one embodiment, the invention comprises an exhaust aftertreatment control system for exhaust gases. The exhaust aftertreatment control system comprises a selective catalytic reduction (SCR) catalyst in fluid communication with an exhaust stream from an engine, a urea solution injector, upstream of the SCR catalyst, in fluid communication with the exhaust stream, a gas sensor, downstream of the SCR catalyst, in fluid communication with the exhaust stream, a diagnostic unit, operatively connected to the engine, and a

2

dosing control unit, operatively connected to the gas sensor, the urea solution injector, and the diagnostic unit. The dosing control unit receives a signal indicative of NO, NO₂ or NH₃ concentrations from the gas sensor, receives a signal indicative of engine parameters from the diagnostic unit, converts the engine parameters to NO and NO₂ concentrations, estimates NO and NO₂ concentrations downstream from the SCR catalyst, estimates the fractional surface coverage of NH₃ in the SCR catalyst, calculates a quantity of urea solution needed to minimize NO_x emissions, and signals the urea solution injector to inject the quantity of the urea solution into the exhaust stream.

In another embodiment, the invention comprises a method for controlling emission of NO_x from an engine with an exhaust aftertreatment system having a NO_x sensor. The method comprises inputting engine parameters into a dosing control unit, measuring NO_x concentration in the exhaust, estimating NO and NO₂ concentrations in the exhaust using the engine parameters and the measured NO_x concentration, estimating fractional surface coverage of NH₃ in the catalyst, calculating an amount of urea solution needed to minimize NO_x emissions using the estimate of NO and NO₂ concentrations in the exhaust and the estimate of fractional surface coverage of NH₃ in the catalyst, and injecting an amount of urea solution.

In another embodiment, the invention comprises a method for controlling emission of NO_x from an engine with an exhaust aftertreatment system having a NH₃ sensor. The method comprises inputting engine parameters into a dosing control unit, measuring NH₃ concentration in the exhaust, estimating NO and NO₂ concentrations in the exhaust using the engine parameters and the measured NH₃ concentration, estimating fractional surface coverage of NH₃ in the catalyst, calculating an amount of urea solution needed to minimize NO_x emissions using the estimate of NO and NO₂ concentrations in the exhaust and the estimate of fractional surface coverage of NH₃ in the catalyst, and injecting an amount of urea solution.

In another embodiment, the invention comprises an exhaust aftertreatment control system for exhaust gases from an industrial burner. The burner may be fueled with a variety of fuels, including natural gas, heating oil, biomass, or municipal solid waste. The exhaust aftertreatment control system comprises a selective catalytic reduction (SCR) catalyst in fluid communication with an exhaust stream from a burner, a urea solution injector, upstream of the SCR catalyst, in fluid communication with the exhaust stream, a gas sensor, downstream of the SCR catalyst, in fluid communication with the exhaust stream, a diagnostic unit, operatively connected to the burner, and a dosing control unit, operatively connected to the gas sensor, the urea solution injector, and the diagnostic unit. The dosing control unit receives a signal indicative of NO, NO₂ or NH₃ concentrations from the gas sensor, receives a signal indicative of burner parameters from the diagnostic unit, converts the burner parameters to NO and NO₂ concentrations, estimates NO and NO₂ concentrations downstream from the SCR catalyst, estimates the fractional surface coverage of NH₃ in the SCR catalyst, calculates a quantity of urea solution needed to minimize NO_x emissions, and signals the urea solution injector to inject the quantity of the urea solution into the exhaust stream.

Other aspects of the invention will become apparent by consideration of the detailed description and accompanying drawings.

BRIEF DESCRIPTION OF THE DRAWINGS

FIG. 1 is a block diagram of an embodiment of an exhaust aftertreatment control system using a NO_x sensor.

FIG. 2 is a block diagram of an embodiment of a dosing control unit for the exhaust aftertreatment control system of FIG. 1.

FIG. 3 is a block diagram of an embodiment of an exhaust aftertreatment control system using a NH_3 sensor.

FIG. 4 is a block diagram of an embodiment of a dosing control unit for the exhaust aftertreatment control system FIG. 3.

FIG. 5 depicts an experimental setup used to verify an estimator.

FIG. 6 shows the engine conditions used to test the four-state model in Example 1, described hereafter.

FIG. 7 shows the measured NO , NO_2 , and NH_3 input concentrations in Example 1, described hereafter.

FIG. 8 compares the estimated NO , NO_2 , and NH_3 output concentrations to experimental data in Example 1, described hereafter.

FIG. 9 compares urea consumption and fractional surface coverage of the SCR catalyst by NH_3 for a NO_x -sensor-based and a NH_3 -sensor-based exhaust aftertreatment system.

FIG. 10 is a block diagram of an embodiment of an exhaust aftertreatment control system using a NO_x sensor.

DETAILED DESCRIPTION

Before any embodiments of the invention are explained in detail, it is to be understood that the invention is not limited in its application to the details of construction and the arrangement of components set forth in the following description or illustrated in the following drawings. The invention is capable of other embodiments and of being practiced or of being carried out in various ways. While the following detailed description describes the invention through reference to embodiments involving an internal combustion engine exhaust treatment system, it should be understood that other systems, both stationary and mobile, where exhaust is treated for NO_x emissions, may also be suitable for a use in accordance with principles of the invention.

Also, it is to be understood that the phraseology and terminology used herein is for the purpose of description and should not be regarded as limiting. The use of "including," "comprising," or "having" and variations thereof herein is meant to encompass the items listed thereafter and equivalents thereof as well as additional items. Unless specified or limited otherwise, the terms "mounted," "connected," "supported," and "coupled" and variations thereof are used broadly and encompass both direct and indirect mountings, connections, supports, and couplings. Further, "connected" and "coupled" are not restricted to physical or mechanical connections or couplings.

Further, no admission is made that any reference, including any patent or patent document, cited in this specification constitutes prior art. In particular, it will be understood that, unless otherwise stated, reference to any document herein does not constitute an admission that any of these documents form part of the common general knowledge in the art in the United States or in any other country. Any discussion of the references states what their authors assert, and the applicant reserves the right to challenge the accuracy and pertinency of any of the documents cited herein.

One approach for controlling NO_x emissions from combustion processes involves adding ammonia (NH_3) to NO_x in the presence of a catalyst to reduce the NO_x to nitrogen and water. This process, known as selective catalytic reduction (SCR), is described with the balanced equation:



A number of known catalysts may be used in the selective reduction process. See, for example, U.S. Pat. No. 5,451,387, which describes catalysts that may be used for this application.

Unfortunately, ammonia poses its own risks to human health and the environment. Ammonia is caustic, and irritates the lungs. Excess ammonia released into the environment often finds its way into the water system, where it threatens the health of plants and animals that contact the water. Because of this risk, selective catalytic reduction with ammonia requires careful monitoring of ammonia emissions as well as NO_x emissions. The unintended release of ammonia is known as ammonia "slip."

For large-scale applications, such as power plants, compressed ammonia gas is used for the catalytic reduction of NO_x to nitrogen and water. However, for small-scale or mobile processes, it is often impractical to store/transport ammonia gas for selective catalytic reduction. In some small-scale systems, it is feasible to use highly concentrated ammonia solutions. Highly concentrated ammonia solutions are caustic, however, and present storage and handling issues.

Urea (NH_2CONH_2) solutions provide a suitable alternative to ammonia gas or ammonia solutions for SCR-based NO_x control systems. In a urea SCR system, an aqueous urea solution is injected into a hot exhaust stream, where the urea thermally decomposes into ammonia and carbon dioxide. The resultant ammonia mixes with the exhaust gas prior to entering a catalytic unit where the NO_x is converted to nitrogen and water. Because urea solutions are unreactive, many of the storage and handling concerns are alleviated.

Urea-SCR systems have seen limited use in diesel trucks and diesel-powered marine vessels. Commercially-available urea-SCR systems typically comprise a urea injector (Bosch GmbH, Stuttgart, Germany), an SCR catalyst, and a NO_x sensor (Siemens VGO Trading Ltd., Schwalbach, Germany). State of the art systems employ a rudimentary look-up table based upon engine parameters to provide a guess for the appropriate urea injection rate. These look-up tables are often subject to error due to engine load and exhaust temperature. The NO_x sensor provides feedback as to when the system is exceeding NO_x limits, allowing the injection rate to be adjusted in an iterative fashion. Alternatively, or in addition, an NH_3 sensor may be used to provide feedback to minimize the amount of ammonia slip.

Because the current systems do not model the catalytic reactions in real time, current systems use more urea solution than necessary and have unacceptable levels of ammonia slip. Additionally, the current systems may be ineffective for controlling NO_x emissions for vehicles that stop and start frequently, e.g., busses and garbage trucks.

The German Association of the Automobile Industry has championed urea-SCR NO_x control, and advocates for a network of filling stations where diesel vehicles can replenish urea solutions. Suitable urea solutions are now commercially-available throughout Europe under the trade name AdBlue. AdBlue solutions comprise 32.5% urea in deionized water, and are sold by BASF, Yara, and GreenChem, among others. These solutions typically cost \$4-7/gal. The rate of consumption varies tremendously depending upon the type of engine and the loading, however, it is not uncommon for an engine to consume 5 gallons of urea solution for each 100 gallons of diesel consumed. The high cost of urea solutions is motivating equipment manufacturers to maximize NO_x control per unit of solution.

The invention described herein provides a closed-loop system for minimizing NO_x emissions from combustion processes while minimizing the consumption of urea solution

and producing negligible ammonia slip. In one embodiment, the aftertreatment system comprises a selective catalytic reduction (SCR) unit, a urea injector, a gas sensor, and a dosing control unit. The gas sensor is sensitive to one or more gases that are to be controlled, including, but not limited to, NO, NO₂, or NH₃. The catalyst within the SCR unit facilitates the conversion of ammonia and NO_x to nitrogen and water. The catalyst may comprise any of a number of catalysts known to work for selective catalytic reduction, including, but not limited to, compounds of vanadium, iron, or copper, and metal zeolites. The urea injector is responsive to the dosing control unit which regulates the concentration of ammonia in the SCR unit by increasing or decreasing the rate of urea injection.

In one embodiment, the gas sensor is a NO_x sensor. The NO_x sensor provides NO_x concentrations to a dosing control unit, thus allowing the dosing control unit to estimate the NO, and NO₂ concentrations upstream from the SCR. In an alternate embodiment, the gas sensor is an NH₃ sensor that provides the NH₃ concentration to the dosing control unit, thus allowing the dosing control unit to estimate the NO, and NO₂ concentrations upstream from the SCR. In both embodiments, the dosing control unit is capable of calculating the optimum urea injection rate to minimize NO_x emissions with minimal ammonia slip.

In many embodiments, the dosing control unit is suitably a single electronic unit. Nonetheless, the dosing control unit can be functionally described as comprising two components, an estimator and a controller. Using engine or burner operating parameters and total NO_x or total NH₃ output, the estimator employs a mathematical model to estimate the concentrations of NO, NO₂, and NH₃ downstream from the SCR catalyst as well as the fractional surface coverage of NH₃ within the SCR catalyst. The estimator then passes these estimates to the controller which calculates the amount of NH₃ needed to minimize NO_x output with minimal NH₃ slip. Having calculated the optimum NH₃ concentration, the controller then directs the urea injector to inject urea at an appropriate rate.

FIG. 1 is a block diagram of an embodiment of an exhaust aftertreatment system 10 employing a NO_x sensor according to the principles of the invention. The exhaust aftertreatment system 10 includes a urea injector 30, a selective catalytic reduction (SCR) catalyst 35, a NO_x sensor 40, and a dosing control unit 50. An internal combustion engine 15 produces an exhaust stream 20 containing nitrogen oxides, including NO and NO₂. As exhaust stream 20 moves through aftertreatment system 10, exhaust stream 20 is mixed with an atomized urea solution 25 from urea injector 30 to create urea-enriched exhaust 32. Urea-enriched exhaust 32 then enters SCR catalyst 35. SCR catalyst 35 contains metal zeolites arranged in a honeycomb such that the passing exhaust gasses will interact with a multitude of catalytic sites. As urea-enriched exhaust 32 is swept into SCR catalyst 35, the urea breaks down into ammonia (NH₃) and carbon dioxide (CO₂). Once inside SCR catalyst 35, the nitrogen oxides react with ammonia in the presence of the metal zeolite to produce nitrogen gas (N₂) and water vapor (H₂O). NO_x sensor 40 measures the NO_x in a scrubbed exhaust stream 37 exiting SCR catalyst 35, and provides a signal indicating the concentration of NO_x to dosing control unit 50. Dosing control unit 50 uses the measured NO_x concentration, as well as operating parameters from engine 15, which originate from an onboard diagnostic unit (OBD) 60. Operating parameters may include exhaust gas temperature, speed, load, air-flow rate, fuel-flow rate and/or exhaust gas pressure. Dosing control unit 50 then calculates

the rate at which atomized urea solution 25 should be mixed with exhaust stream 20, and adjusts urea injector 30 accordingly.

Dosing control unit 50 is an electronic control unit comprising random access memory (RAM) 52, read only memory (ROM) 55, and a microprocessor (CPU) 58. Functionally, dosing control unit 50 may be described as comprising an estimator 70 and a controller 80, as shown in FIG. 2. Estimator 70 collects information about the engine from OBD 60, as well as information from NO_x sensor 40. Using this information, estimator 70 estimates the concentration of NO, NO₂, and NH₃ in exhaust stream 20, prior exhaust stream 20 entering SCR catalyst 35. Estimator 70 also estimates the NH₃ loading, θ , in the catalyst using equation VIII, discussed hereafter. Controller 80 then uses the estimated NH₃ loading and the NO, NO₂ and NH₃ concentrations as inputs to equation XIV, described hereafter. Controller 80 then adjusts the rate at which atomized urea solution 25 is injected exhaust stream 20 to minimize NO, NO₂ and NH₃ emissions in scrubbed exhaust stream 37.

The estimator employs a four-state model to estimate the concentrations of NO, NO₂ and NH₃ within SCR catalyst 35. The four-state model encompasses six chemical equations (I-VI) which describe the simultaneous reactions within SCR catalyst 35

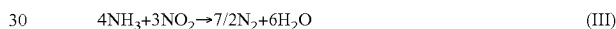
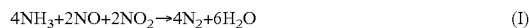

wherein S represents the free active sites in the catalyst, and NH₃* is NH₃ adsorbed at an active site in the catalyst. Incorporating the appropriate rate constants for chemical reactions I-VI, the time-dependent states of NO, NO₂, NH₃, and the ammonia storage in the catalyst can be represented as

$$\dot{C}_{\text{NO}}=-\bar{Q}C_{\text{NO}}-k_1\Omega\theta C_{\text{NO}}C_{\text{NO}_2}-k_2\Omega\theta C_{\text{NO}}C_{\text{O}_2}+\bar{Q}C_{\text{NO},in}$$

$$\dot{C}_{\text{NO}_2}=-\bar{Q}C_{\text{NO}_2}-k_1\Omega\theta C_{\text{NO}}C_{\text{NO}_2}-k_3\Omega\theta C_{\text{NO}_2}+\bar{Q}C_{\text{NO}_2,in}$$

$$\dot{\theta}=-\frac{(k_6+k_4)\theta+k_5C_{\text{NH}_3}-k_1C_{\text{NO}}C_{\text{NO}_2}\theta-k_2C_{\text{NO}}C_{\text{O}_2}\theta}{k_3C_{\text{NO}_2}\theta-k_5\theta C_{\text{NH}_3}}$$

$$\dot{C}_{\text{NH}_3}=k_6\Omega\theta-(k_5\Omega+\bar{Q})C_{\text{NH}_3}+k_5\Omega\theta C_{\text{NH}_3}+\bar{Q}k_5C_{\text{NH}_3,in} \quad (\text{VII})$$

wherein

\bar{Q} is the normalized flow rate into the SCR catalyst 35 in sec⁻¹, wherein $\bar{Q}=Q/V$, and Q is the actual volumetric flow rate in actual m³/sec, and V is the volume of the exhaust gas in the substrate channel in m³,

C_i is the concentration of species i in moles/m³, where i=NO, NO₂, NH₃, or O₂,

$C_{i,in}$ is the concentration of species i entering SCR catalyst 35, where i=NO, NO₂, NH₃,

θ is the fractional surface coverage of SCR catalyst 35 by NH₃,

Ω is SCR catalyst 35 adsorption capacity in moles of NH₃/m³,

k_1 is the rate constant for equation I,

k_2 is the rate constant for equation II,

k_3 is the rate constant for equation III,

k_4 is the rate constant for equation IV,

k_5 is the rate constant for equation V,

k_6 is the rate constant for equation VI.

In one embodiment, an estimator would employ a converging linear state equation of the form

$$\begin{cases} \dot{\hat{C}}_{NO,est} \\ \dot{\hat{C}}_{NO_2,est} \\ \dot{\hat{\theta}}_{est} \\ \dot{\hat{C}}_{NH_3,est} \end{cases} = \vec{f}(C_{NO,est}, C_{NO_2,est}, \theta_{est}, C_{NH_3,est}, C_{NO,in}, C_{NO_2,in}) + \vec{L}(C_{NO,meas} + C_{NO_2,meas} - C_{NO,est} - C_{NO_2,est}) \quad (\text{VIII})$$

to estimate θ and the concentrations of NO, NO₂, and NH₃ downstream from the SCR catalyst. \vec{L} serves to stabilize the estimator. That is, when the system begins, it is necessary to employ an estimate for the NO and NO₂, however, once the system is running, the measured and estimated values of NO and NO₂ should converge, and \vec{L} will consequently disappear. The estimator's ability to predict concentrations of NO, NO₂, and NH₃ was verified experimentally, as described hereafter in Example 1.

For some applications, it may be computationally expensive to estimate the four states using equation VIII. In an alternative embodiment, an acceptable estimate may be obtained quicker and/or with less computational resources by solving $\dot{\hat{C}}_{NO}$, $\dot{\hat{C}}_{NO_2}$, and $\dot{\hat{C}}_{NH_3}$ as steady state expressions. This approximation results in a single state model for the fractional NH₃ coverage in the catalyst

$$\dot{\theta} = -(k_6 + k_4)\theta + k_5 C_{NH_3} - k_1 C_{NO} C_{NO_2} \theta - k_2 C_{NO} C_{O_2} \theta - k_3 C_{NO_2} \theta - k_3 \theta C_{NH_3} \quad (\text{IX})$$

and a corresponding linear state estimator of the form

$$\dot{\hat{\theta}}_{est} = \vec{f}(C_{NO}, C_{NO_2}, \theta, C_{NH_3}, C_{NO,in}, C_{NO_2,in}, C_{NH_3,in}) + \vec{L}(C_{NO_x,meas} - C_{NO_x,est}) \quad (\text{X})$$

where $C_{NO_x,meas}$ is the measurement from the NO_x sensor **16**. Because the NO_x sensor is cross-sensitive to NH₃, $C_{NO_x,est}$ must actually incorporate an estimate of the downstream NH₃ concentration. Thus, $C_{NO_x,est}$ is

$$C_{NO_x,est} = A_1 C_{NO} + A_2 C_{NO_2} + A_3(\alpha) C_{NH_3} \quad (\text{XI})$$

where A_1 , A_2 , and $A_3(\alpha)$ are specific to the aftertreatment control system.

The initial concentrations of NO and NO₂ are calculated by estimator **70** using a model specific for internal combustion engine **15** and additional emission equipment that may lie between internal combustion engine **15** and SCR **35** (e.g. a catalyzed particulate filter). Onboard diagnostic unit **60** reports engine parameters, such as engine speed, load, exhaust gas temperatures, flow rates and exhaust gas pressure, to estimator **70**. Estimator **70** uses these engine parameters to produce an estimate of NO and NO₂ concentrations for the purpose of estimating C_{NO_x} . Estimator **70** also estimates the NH₃ entering SCR catalyst **35** based upon the rate that urea injector **30** is injecting atomized urea solution **25** into exhaust stream **20** previous to urea-enriched exhaust **32** entering SCR catalyst **35**.

Controller **80** functions to minimize the NO, NO₂, and NH₃ in scrubbed exhaust stream **37** while using as little atomized urea solution **25** as necessary. The controller's efficiency at converting NO and NO₂ to N₂ per mole of NH₃ can be expressed as

$$\eta_T = \frac{C_{NO,in} + C_{NO_2,in} - C_{NO,out} - C_{NO_2,out} - \lambda C_{NH_3,out}}{C_{NO,in} + C_{NO_2,in}} \quad (\text{XIII})$$

wherein λ accounts for NH₃ slipping out of the catalyst.

Defining a new function $e_p = \bar{p}_{des} - \bar{p}_2$ where \bar{p} is a linear combination of C_{NO} , C_{NO_2} , C_{NH_3} , and \bar{p}_{des} is a linear combination of the desired concentrations, i.e., $\bar{p}_{des} = C_{NO,des} + C_{NO_2,des} + \alpha C_{NH_3,des}$ the controller's goal can be represented as $e_p = \dot{e}_p = 0$.

Substituting $\eta_T = 1 - p_{des}$, the dynamic concentration of NH₃ within the SCR catalyst **15** for the goal $e_p = \dot{e}_p = 0$ can be expressed as,

$$\begin{aligned} C_{NH_3,in,dyn} = & C_{NH_3,est} + \frac{1}{\lambda}(C_{NO,est} + C_{NO_2,est} - C_{NO,in} - C_{NO_2,in}) + \\ & \frac{1}{Q}(k_5 \Omega(1 - \theta_{est}) C_{NH_3,est} - k_6 \Omega \theta_{est}) + \\ & \frac{1}{\lambda Q}(\dot{\bar{p}}_{des} + 2\Omega \theta_{est} k_1 C_{NO,est} C_{NO_2,est} + \\ & \Omega \theta_{est} k_2 C_{NO,est} C_{O_2} + \Omega \theta_{est} k_3 C_{NO_2,est}) \end{aligned} \quad (\text{XIV})$$

As the system, in accordance with the invention, is subject to nonlinear dynamics, controller **80** must employ an additional correction term to ensure stability in the event of measurement errors or other transient disturbances. Therefore, an additional term is added that penalizes deviations from the objective $e_p = 0$.

$$C_{NH_3,in} = C_{NH_3,in,dyn} - \Gamma \text{sgn}(e_p) \quad (\text{XV})$$

where Γ is a control variable that can be tuned to meet the control objective. Based upon the sign of $\text{sgn}(e_p)$, the signum function changes:

$$\text{sgn}(x) = \begin{cases} -1: x < 0 \\ 0: x = 0 \\ 1: x > 0 \end{cases} \quad (\text{XVI})$$

Thus, given estimates of NO, NO₂, NH₃ and free catalytic sites from estimator **70**, controller **80** calculates the optimum concentration of ammonia to achieve its efficiency goals. Upon calculating this value, controller **80** adjusts the rate of injection of atomized urea solution **25** from injector **30** assuming a 2:1 molar ratio of ammonia to atomized urea solution **25**.

As an alternative to NO_x sensor **40** downstream of SCR catalyst **35**, an NH₃ sensor **140** can be used for SCR control applications. See FIG. 3. NH₃ sensor **140** has the additional, beneficial, characteristic of having minimal cross-sensitivity toward NO and NO₂ species, as is reported in the literature (See Wang, DEER 2007; Moos, *Sensors and Actuators*, 2002.) Because of the minimal cross-sensitivity, ammonia-sensor-based exhaust aftertreatment system **110** requires fewer variables than exhaust aftertreatment system **10**, employing NO_x sensor **40**.

FIG. 3 is a block diagram depicting an ammonia-sensor-based exhaust aftertreatment system **110** embodying the principles of the invention for catalytic reduction of NO_x in the presence of ammonia. The ammonia-sensor-based exhaust aftertreatment system **110** includes urea injector **30**, SCR catalyst **35**, an NH₃ sensor **140**, and an ammonia-sensor-

based dosing control unit **150**. Internal combustion engine **15** produces exhaust stream **20** containing nitrogen oxides, including NO and NO₂. As exhaust stream **20** moves through the ammonia-sensor-based aftertreatment system **110**, exhaust stream **20** is mixed with atomized urea solution **25** from urea injector **30** to create urea-enriched exhaust **32**. Urea-enriched exhaust **32** then enters SCR catalyst **35**. SCR catalyst **35** contains metal zeolites arranged in a honeycomb such that the passing exhaust gasses will interact with a multitude of catalytic sites. As urea-enriched exhaust **32** is swept into SCR catalyst **35**, the urea breaks down into ammonia (NH₃) and carbon dioxide (CO₂). Once inside SCR catalyst **35**, the nitrogen oxides react with ammonia in the presence of the metal zeolites to produce nitrogen gas (N₂) and water vapor (H₂O). NH₃ sensor **140** measures the NH₃ exiting SCR catalyst **35**, providing a signal indicating the concentration of NH₃ in scrubbed exhaust stream **37** to the ammonia-sensor-based dosing control unit **150**. Ammonia-sensor-based dosing control unit **150** uses the measured NH₃ concentration, as well as internal combustion engine **15** operating parameters, which originate from OBD **60**. Engine parameters may include exhaust gas temperature, speed, load, air-flow rate, fuel-flow rate and/or exhaust gas pressure. Ammonia-sensor-based dosing control unit **150** then calculates the rate at which the atomized urea solution **25** should be mixed with exhaust stream **20**, and adjusts injector **30** accordingly.

Ammonia-sensor-based dosing control unit **150** is an electronic control unit comprising random access memory (RAM) **152**, read only memory (ROM) **155**, and a microprocessor (CPU) **158**. Functionally, the ammonia-sensor-based dosing control unit **150** may be described as comprising an ammonia-sensor-based estimator **170** and an ammonia-sensor-based controller **180**. The functions of ammonia-sensor-based estimator **170** and ammonia-sensor-based controller **180** are illustrated in FIG. 4. Ammonia-sensor-based estimator **170** collects information about the engine from OBD **60**, as well as information from NH₃ sensor **140**. Using this information, ammonia-sensor-based estimator **170** estimates the concentration of NO, NO₂, and NH₃ in exhaust stream **20**, prior to exhaust stream **20** entering SCR catalyst **35**. Ammonia-sensor-based estimator **170** also estimates the NH₃ loading, θ , in the catalyst using equation VIII, discussed above. Ammonia-sensor-based controller **180** then uses the estimated NH₃ loading and the NO, NO₂ and NH₃ concentrations as inputs to equation XIV, described previously. Ammonia-sensor-based controller **180** then adjusts the rate at which atomized urea solution **25** is injected into exhaust stream **20** to minimize NO, NO₂ and NH₃ in scrubbed exhaust stream **37**.

Ammonia-sensor-based estimator **170** employs the same four-state model, described above with respect to equations (I)-(VII), to estimate the concentrations of NO, NO₂ and NH₃ within SCR catalyst **35**. However, ammonia-sensor-based estimator **170** employs a modified converging linear state equation of the form

$$\begin{pmatrix} \dot{C}_{NO,est} \\ \dot{C}_{NO_2,est} \\ \dot{\theta}_{est} \\ \dot{C}_{NH_3,est} \end{pmatrix} = \vec{f}(C_{NO,est}, C_{NO_2,est}, \theta_{est}, C_{NH_3,est}, C_{NO,in}, C_{NO_2,in}) + \vec{L}(C_{NH_3,meas} - C_{NH_3,est}) \quad (XVII)$$

to estimate θ and the concentrations of NO, NO₂, and NH₃ downstream from the SCR catalyst. \vec{L} serves to stabilize the estimator. That is, when the system begins, it is necessary to employ an estimate for the NH₃, however, once the system is running, the measured and estimated values of NH₃ should converge, and \vec{L} will consequently disappear.

For some applications, it may be computationally expensive to estimate the four states using equation XVII. In an alternative embodiment, an acceptable estimate may be obtained quicker and/or with less computational resources by solving \dot{C}_{NO} , \dot{C}_{NO_2} , and \dot{C}_{NH_3} as steady state expressions. Using equation (IX), above, to describe a single state model for the fractional NH₃ coverage in the catalyst, a corresponding linear state estimator for the use of an NH₃ sensor **140** can be determined

$$\dot{\theta}_{est} = \vec{f}(C_{NO}, C_{NO_2}, \theta_{est}, C_{NH_3}, C_{NO,in}, C_{NO_2,in}, C_{NH_3,in}) + \vec{L}(C_{NH_3,meas} - C_{NH_3,est}) \quad (XVIII)$$

where $C_{NH_3,meas}$ is the NH₃ concentration measured by the NH₃ sensor **140**, and $C_{NH_3,est}$ is calculated based upon an NH₃ sensor model given by

$$C_{NH_3,est} = A_3(\alpha)C_{NH_3} \quad (XIX)$$

where A_3 is determined as a function of α , which is specific to ammonia-sensor-based aftertreatment control system **110**.

The initial concentrations of NO and NO₂ are calculated by ammonia-sensor-based estimator **170** using a model specific for internal combustion engine **15** and additional emission equipment that may lie between internal combustion engine **15** and SCR **35** (e.g. a catalyzed particulate filter). OBD **60** reports engine parameters, such as engine speed, load, exhaust gas temperatures, flow rates and exhaust gas pressure, to ammonia-sensor-based estimator **170**. Ammonia-sensor-based estimator **170** uses these engine parameters to produce an estimate of NO and NO₂ concentrations for the purpose of estimating C_{NH_3} . The estimator also estimates the NH₃ entering SCR catalyst **35** based upon the rate that urea injector **30** is injecting atomized urea solution **25** into the exhaust stream previous to entering SCR catalyst **35**.

Ammonia-sensor-based controller **180** functions to minimize the NO, NO₂, and NH₃ leaving the aftertreatment system, while using as little atomized urea solution **25** as necessary, as is described in equation (XIII) above. However, because NH₃ sensor **140** measures the NH₃ slip directly, it is unnecessary to calculate a dynamic NH₃ concentration after the SCR as is done in the NO_x-sensor-based exhaust aftertreatment system **10**. Thus, given estimates of NO, NO₂, NH₃ and free catalytic sites from ammonia-sensor-based estimator **170**, ammonia-sensor-based controller **180** can calculate the optimum concentration of ammonia to achieve its efficiency goals. Upon calculating this value, ammonia-sensor-based controller **180** adjusts the rate of atomized urea solution **25** injection from injector **130** assuming a 2:1 molar ratio of ammonia to atomized urea solution **25**.

EXAMPLE 1

Verification of Four-State Model

FIG. 5 depicts an experimental setup in accordance with the invention. A Navistar I6 7.6 L diesel engine **210** was connected to a diesel oxidation catalyst **230** and a catalyzed particulate filter **240**, and then outfitted with urea injector **30** and a first SCR catalyst **35** and a second SCR catalyst **38**. [Generally an exhaust aftertreatment system would have only one SCR catalyst, as is depicted in FIG. 1.] The exhaust

concentrations of NO and NO₂ were measured before first SCR catalyst **35** with a first emission test bench **250** and after second SCR catalyst **38** with a second emission test bench **255**. The NH₃ concentrations were measured before first SCR catalyst **35** with a first Fourier Transform Infrared Spectrometer (FTIR) **260** and after second SCR catalyst **38** with a second Fourier Transform Infrared Spectrometer (FTIR) **265**.

Engine **210** was run at a variety of speed and load conditions as shown in FIG. 6, resulting in a variety of engine temperatures and exhaust gas flow rates. The rate of urea injection was adjusted manually. FIG. 7 shows the NO and NO₂ concentrations measured with first emission test bench **250** during the engine conditions depicted in FIG. 6. The NH₃ concentration in FIG. 7 was calculated from the rate of urea injection in FIG. 6.

The resulting NO and NO₂ concentrations were measured with second emission test bench **255**. The resulting NH₃ concentrations were measured with second FTIR **265**. These measurements are illustrated with dashed lines in FIG. 8. For comparison, the NO, NO₂, and NH₃ concentrations after first and second SCR catalysts **35** and **38** were estimated using the four state model (Equation VIII), engine **210** parameters, and the rate of urea solution injection. The estimated concentrations are depicted with a solid line.

As illustrated in FIG. 8, the four-state model provides a suitable method for estimating NO, NO₂, and NH₃ concentrations.

As a final verification of the robustness of the invention described herein, the NO_x sensor model, described by equation (VIII) was used to control the rate of urea injection in the setup shown in FIG. 5, and then the NH₃ sensor model, described by equation (XVII) was used to control the rate of urea injection in a similar experimental setup. As can be seen in FIG. 9, both sensor models result in similar rates of urea injection and fractional surface coverage, θ , of the SCR catalyst by NH₃.

EXAMPLE 2

Controlling NO_x Emissions From Industrial Burner

FIG. 10 is a block diagram of a prophetic embodiment of an exhaust aftertreatment system **310** employing a NO_x sensor according to the principles of the invention. The exhaust aftertreatment system **310** will include a urea injector **30**, a selective catalytic reduction (SCR) catalyst **35**, a NO_x sensor **40**, and a dosing control unit **50**. An oil-fueled industrial burner **315** (used to power a 66 MW steam generator) will produce an exhaust stream **20** containing nitrogen oxides, including NO and NO₂. Exhaust stream **20** will move through aftertreatment system **310**, exhaust stream **20** will be mixed with an atomized urea solution **25** from urea injector **30** to create urea-enriched exhaust **32**. Urea-enriched exhaust **32** will then enter SCR catalyst **35**. SCR catalyst **35** will contain metal zeolites arranged in a honeycomb such that the passing exhaust gasses will interact with a multitude of catalytic sites. As urea-enriched exhaust **32** is swept into SCR catalyst **35**, the urea will break down into ammonia (NH₃) and carbon dioxide (CO₂). Once inside SCR catalyst **35**, the nitrogen oxides will react with ammonia in the presence of the metal zeolite to produce nitrogen gas (N₂) and water vapor (H₂O). NO_x sensor **40** will measure the NO_x in a scrubbed exhaust stream **37** exiting SCR catalyst **35**, and will provide a signal indicating the concentration of NO_x to dosing control unit **350**. Dosing control unit **350** will use the measured NO_x concentration, as well as operating parameters from industrial burner **315**, which will originate from a burner diagnos-

tics unit **360**. Operating parameters will include exhaust gas temperature, steam load, steam temperature, air-flow rate, fuel-flow rate and exhaust gas pressure. Dosing control unit **350** then will calculate the rate at which atomized urea solution **25** will be mixed with exhaust stream **20**, and will adjust urea injector **30** accordingly. Dosing control unit **350** is an electronic control unit comprising random access memory (RAM) **52**, read only memory (ROM) **55**, and a microprocessor (CPU) **58**. Functionally, dosing control unit **350** will be nearly identical to dosing control unit **50**, shown in FIG. 2. Dosing control unit will be programmed to estimate the concentration of NO_x in exhaust stream **20** based upon empirical measurements of NO_x in exhaust stream **20** under various operating conditions.

Thus, the invention provides systems and methods for the reduction of NO_x emissions from a combustion process by measuring engine parameters and concentrations of NO_x or NH₃, estimating NO and NO₂ concentrations, injecting a urea solution into the exhaust stream, and selectively reducing NO_x to N₂ in the presence of a catalyst. The methods and systems minimize urea solution consumption at the same time they minimize NO_x and ammonia emissions.

The above embodiments and examples do not serve as limitations on the invention, as other embodiments may employ the principles of the invention described herein. For example, the principles of the invention may be employed to create an exhaust aftertreatment system for NO_x reduction in industrial burners, such as those used in furnaces, boilers, or power plants. These burners may be powered by a variety of fuels, including, but not limited to, natural gas, heating oil, biomass, or municipal solid wastes.

Furthermore, Example 1 does not indicate that the invention is limited to diesel engines such as those used for over-the-road trucking. With only minor modifications, one skilled in the art could apply the principles of the invention described herein to reduce NO_x emissions from any diesel powered vehicle or equipment, including locomotives, construction equipment, earthmoving equipment, or marine craft.

All publications, patents, and patent applications are herein expressly incorporated by reference to the same extent as if each individual publication, patent, or patent application was specifically and individually indicated by reference. In case of conflict between the present disclosure and the incorporated patents, publications and references, the present disclosure should control.

Various features and advantages of the invention are set forth in the following claims.

What is claimed is:

1. An exhaust aftertreatment control system for exhaust gases, comprising:
 - a selective catalytic reduction (SCR) catalyst in fluid communication with an exhaust stream from an engine,
 - a urea solution injector, upstream of the SCR catalyst, in fluid communication with the exhaust stream;
 - a gas sensor, downstream of the SCR catalyst, in fluid communication with the exhaust stream;
 - a diagnostic unit, operatively connected to the engine; and
 - a dosing control unit, operatively connected to the gas sensor, the urea solution injector, and the diagnostic unit, wherein the dosing control unit receives a signal indicative of NO, NO₂ or NH₃ concentrations from the gas sensor, receives a signal indicative of engine operating parameters from the diagnostic unit, converts the engine operating parameters to a NO concentration and a NO₂ concentration, estimates a NO concentration downstream from the SCR catalyst, estimates a NO₂ concentration downstream from the SCR catalyst, estimates the

13

fractional surface coverage of NH_3 in the SCR catalyst, calculates a quantity of urea solution needed to minimize NO_x emissions, and signals the urea solution injector to inject the quantity of the urea solution into the exhaust stream.

2. The exhaust aftertreatment control system of claim 1, wherein the gas sensor is a NO_x sensor.

3. The exhaust aftertreatment control system of claim 1, wherein the gas sensor is an NH_3 sensor.

4. The exhaust aftertreatment control system of claim 1, wherein the engine is a diesel engine.

5. The exhaust aftertreatment control system of claim 1, wherein the engine parameters are selected from the group consisting of engine speed, engine load, engine temperature, exhaust gas temperature, exhaust flow rate, and exhaust pressure.

6. The exhaust aftertreatment control system of claim 1, wherein the dosing control unit uses a converging linear state equation to calculate the quantity of urea solution needed to minimize NO_x emissions.

7. The exhaust aftertreatment control system of claim 1, wherein the selective catalytic reduction catalyst is chosen from the group consisting of vanadium compounds, iron compounds, copper compounds, and metal zeolites.

8. An exhaust aftertreatment control system for exhaust gases, comprising:

a selective catalytic reduction (SCR) catalyst in fluid communication with an exhaust stream from a burner,

14

a urea solution injector, upstream of the SCR catalyst, in fluid communication with the exhaust stream;

a gas sensor, downstream of the SCR catalyst, in fluid communication with the exhaust stream;

a burner diagnostic unit, operatively connected to the burner; and

a dosing control unit, operatively connected to the gas sensor, the urea solution injector, and the burner diagnostic unit, wherein the dosing control unit receives a signal indicative of NO , NO_2 or NH_3 concentrations from the gas sensor, receives a signal indicative of burner operating parameters from the burner diagnostic unit, converts the burner operating parameters to NO and NO_2 concentrations, estimates a NO concentration and a NO_2 concentration downstream from the SCR catalyst, estimates the fractional surface coverage of NH_3 in the SCR catalyst, calculates a quantity of urea solution needed to minimize NO_x emissions, and signals the urea solution injector to inject the quantity of the urea solution into the exhaust stream.

9. The exhaust aftertreatment control system of claim 8, wherein the gas sensor is a NO_x sensor.

10. The exhaust aftertreatment control system of claim 8, wherein the gas sensor is an NH_3 sensor.

11. The exhaust aftertreatment control system of claim 8, wherein the burner is supplied with a fuel selected from the group consisting of natural gas, heating oil, biomass, or municipal solid waste.

* * * * *