

South Korean elementary teachers' knowledge for teaching mathematics

Author: Rina Kim

Persistent link: <http://hdl.handle.net/2345/bc-ir:104388>

This work is posted on [eScholarship@BC](#),
Boston College University Libraries.

Boston College Electronic Thesis or Dissertation, 2014

Copyright is held by the author, with all rights reserved, unless otherwise noted.

BOSTON COLLEGE

Lynch School of Education

Department of
Teacher Education, Special Education, and Curriculum and Instruction

Curriculum and Instruction

SOUTH KOREAN ELEMENTARY TEACHERS' KNOWLEDGE FOR TEACHING MATHEMATICS

Dissertation
by

RINA KIM

submitted in partial fulfillment
of the requirements for the degree of
Doctor of Philosophy

May 2014

© Copyright by RINA KIM

2014

SOUTH KOREAN ELEMENTARY SCHOOLTEACHERS' KNOWLEDGE FOR TEACHING MATHEMATICS

By Rina Kim

Lillie Richardson Albert, Ph.D., Chair

Abstract

The purpose of this research is to identify the categories of South Korean elementary teachers' knowledge for teaching mathematics. Operating under the assumption that elementary teachers' knowledge for teaching affects students' learning, eleven South Korean elementary teachers volunteered to participate in this study. Emerging from the data collected and the subsequent analysis are five categories of South Korean elementary teachers' knowledge for teaching mathematics: Mathematics Curriculum Knowledge, Mathematics Learner Knowledge, Fundamental Mathematics Conceptual Knowledge, Mathematics Pedagogical Content Knowledge, and Mathematics Pedagogical Procedural Knowledge. The first three categories of knowledge play a significant role in mathematics instruction as an integrated form within Mathematics Pedagogical Content Knowledge.

A notable conclusion of this study is that Pedagogical Content Knowledge might not be the sum of the other categories of knowledge for teaching mathematics. These findings may be connected to results from relevant studies in terms of the significant role of teachers' knowledge in their mathematics instruction. This study contributes to the existing literature in that it provides empirical bases for understanding teachers' knowledge for teaching mathematics and reveals the relationship among categories of knowledge for teaching mathematics.

DEDICATION

This study is dedicated to

Teachers

Hwan Gwan Kim
Myoung Sook Yang
My parents and my first teachers

Dr. Hang Gyun Sihm
Dr. Lillie R. Albert
My mentors and friends

Acknowledgements

The development of this study, collection of data, and the subsequent writing of the dissertation were, in large part, made possible by the tireless effort of Dr. Lillie R. Albert. You were inspirational when I felt defeated and tough when my focus wandered. Dr. Albert, a mere thank you does not begin to express my deep gratitude for your time and guidance.

To my committee members, Drs. David Scanlon and Margaret Kenney, thank you. You always issued challenges within the supportive framework of your understanding to move this project forward to completion. Your insights were invaluable and were embedded in the context of this work; your critical import to this project's success was certainly known to me.

To my family members, thank you. You have helped me stay sane through these difficult years. Your support and care helped me overcome setbacks and stay focused on my graduate study. I deeply appreciate your belief in me. I am also grateful to my Boston families that helped me adjust to a new country.

Also, I want to thank my friends for their constant support and encouragement. In particular, I am grateful to the following people: BoKyoung Kim, HyunJin Kim, SuYoen Park, NaYoung Jeong, SoYoung Yoon, JaeHyuck Jeoung, JunHo Kim, HyeRyoung Choi, BongWoo Kim, WonJae Lee, BongSeuk Kim, JangHo Joe, SangGeun Kim, SungHwan Hwang, YooKyoung Kim, JiSoo Shin, DaeSik Kim, Jina Ro, NaYoung Kwon and Valerie Spencer.

My sincere appreciation goes to my mentor and collaborator, Professor Hang Gyun Sihm of Seoul National University of Education, Seoul, South Korea.

TABLE OF CONTENTS

Title.....	i
Copyright	ii
Abstract.....	iii
Dedication.....	iv
Acknowledgement	v
CHAPTER 1: Introduction	1
Purpose of the Study and Research Questions.....	5
Framework	7
Theoretical Orientation	7
Conceptual Framework	9
Importance of Study.....	11
Definition of Terms.....	14
Overview of Chapters	16
CHAPTER 2: Review of the Literature	19
Sociocultural Theory.....	20
History of Research on Teachers' Knowledge for Teaching Mathematics ...	23
.....	23
Research on Teachers' Knowledge for Teaching Mathematics	23
Historical Context of Research on Teachers' Knowledge for Teaching	
Mathematics in South Korea.....	27
Research on Teachers' Knowledge for Teaching Mathematics	31
Conceptual Studies on Categories of Teachers' Knowledge for Teaching	
Mathematics	34

Empirical Studies on Categories of Teachers' Knowledge for Teaching	
Mathematics	45
Interpretive Summary and Critical Analysis.....	67
CHAPTER 3: Methodology.....	70
Research Design.....	71
Multiple Case Studies Approach	71
Sociolinguistic Tradition and Grounded Theory	72
Access and Entry	75
Participants.....	76
Settings	79
Data Collection	87
Interviews	87
Observations.....	89
Lesson Plans.....	89
Procedures	90
Data Analysis	90
Limitation of the Study	95
Researcher Positionality.....	96
CHAPTER 4: Context of Elementary Mathematics Education in South Korea ...	98
The National Curriculum in South Korea.....	99
The National Curriculum and Education Fever in South Korea.....	105
The National Mathematics Curriculum at the Elementary Level in South Korea	
.....	110

Summary	117
CHAPTER 5: Knowledge for Teaching Mathematics Category I: Mathematics Curriculum Knowledge (MCK)	119
Mathematics Curriculum Knowledge	120
Mathematics Curriculum Knowledge in Mathematics Instruction	122
Using MCK When Developing and Instructional Process	122
Using MCK When Teaching the Lesson in a Classroom	135
Using MCK When Assessing Students' Work	137
Interpretative Summary	140
CHAPTER 6: Knowledge for Teaching Mathematics Category II: Mathematics Learner Knowledge (MLK).....	143
Mathematics Learner Knowledge	144
Mathematics Learner Knowledge in Mathematics Instruction	153
Using MLK When Developing and Instructional Process.....	154
Using MCK When Teaching the Lesson in a Classroom	163
Using MLK When Assessing Students' Work	167
Interpretative Summary	170
CHAPTER 7: Knowledge for Teaching Mathematics Category III: Fundamental Mathematics Conceptual Knowledge (FMCK)	173
Fundamental Mathematics Conceptual Knowledge	174
Fundamental Mathematics Conceptual Knowledge in Mathematics Instruction	178
Using FMCK When Developing and Instructional Process	179
Using FMCK When Teaching the Lesson in a Classroom	187
Using FMLK When Assessing Students' Work	198
Interpretative Summary	201

CHAPTER 8: Knowledge for Teaching Mathematics Category IV: Mathematics Pedagogical Content Knowledge (MPCK) and Mathematics Pedagogical Procedural Knowledge (MPPK).....	204
The Nature of Categories of Knowledge for Teaching Mathematics	205
The Relationship Among Categories of Knowledge for Teaching Mathematics	209
Mathematics Pedagogical Content Knowledge	221
Mathematics Pedagogical Procedural Knowledge	226
The Structure of South Korean Elementary Teachers' Knowledge for Teaching Mathematics	231
Interpretative Summary	234
CHAPTER 9: Summary, Conclusions and Implications	237
Summary of the Study	237
Discussion of Findings.....	243
Mathematics Curriculum Knowledge	243
Mathematics Learner Knowledge.....	244
Fundamental Mathematics Conceptual Knowledge	246
Mathematics Pedagogical Content Knowledge and Mathematics Pedagogical Procedural Knowledge.....	247
Conclusion and Implications.....	248
Limitations of This Study	253
Recommendations for Future Research	254
Closing Comments.....	255
REFERENCES	256
APPENDICES	285
A. Appendix A: The Review of the Empirical Studies.....	285

B. Appendix B: Informed Consent Form	291
C. Appendix C: Interview Protocols.....	298
D. Appendix D: An Example of a Sixth-Grade South Korean National Teachers’ Guidebook.....	308

LIST OF FIGURES

Figure	Page
1.1 Teachers' Role of Languages in Mathematics Instruction	8
1.2 The Conceptual Framework.....	10
2.1 Shulman's Key Categories of Teachers' Knowledge	35
2.2 Components of Mathematics Teachers' Knowledge	39
2.3 Key Domains of Teachers' Knowledge for Teaching Mathematics.....	42
3.1 The Process of Organizing Data	92
4.1 Diverse Managing Process of the Curriculum	100
5.1 The Flow of Learning from Mrs. Kim's Lesson Plan.....	123
5.2 The Flow of Learning from Mrs. Choi's Lesson Plan	124
6.1 The Flow of Learning from Mr. Bae's Lesson Plan	151
6.2 Diverse Parallelograms	155
6.3 Diverse Parallelograms Made with Tangram Pieces	156
6.4a The process of each Activity from Mrs. Jeong's Mathematics Instruction	161
6.4b The process of each Activity from Mrs. Jeong's Mathematics Instruction	162
7.1 An Example of Concept of a Rectangle.....	175
7.2 Example of ICMK and EMCK	178
7.3 The Structure of Tangrams	180
7.4 Two Sensory Experience Model for Addition with Natural Numbers	185
7.5 Mrs. Yang's IMCK regarding the Basic Concepts of the Base-10 System and Place Value	190
7.6 A Student's Inappropriate Model of a Cylinder	194
8.1 Networks of Knowledge	207

8.2	The Flow of Learning from Mrs. Kim's Lesson Plan.....	212
8.3	Teachers' Decision on the Range of Each Category	213
8.4	The Definition of Intersection from the Connections between Categories	217
8.5	Intersection between Two Types of Categories of Knowledge I.....	218
8.6	Intersection between Two Types of Categories of Knowledge II	219
8.7	Intersection between Two Types of Categories of Knowledge III	220
8.8	Intersection among the Categories of Teachers' Knowledge for Teaching Mathematics	222
8.9	The Model for Mathematics Pedagogical Procedural Knowledge	229
8.10	The Structure of South Korean Elementary Teachers' Knowledge for Teaching Mathematics	232

LIST OF TABLES

Table	Page
3.1	Information about Participants.....79
3.2	Relationship between Components and the Interview Questions.....88
3.3	Findings and Data Triangulation94
4.1	The Objectives of the Elementary Mathematics Education.....111
4.2	The Objectives of the Chapter from Mrs. Choi’s Lesson Plan for Grade 6113
4.3	The Objectives of the Chapter from Mr. Bae’s Lesson Plan for Grade 6113
4.4	The Organization of Mathematics Topics.....114
5.1	Mrs. Kim’s Survey on Students’ Mathematical Understanding125
5.2	Mrs. Choi’s Survey on Students’ Mathematical Skills.....125
5.3	Mrs. Kim’s Lesson Plan.....127
5.4	Mrs. Choi’s Lesson Plan.....129
5.5	Mrs. Kim’s Deployment Plan for the Textbook Chapter.....131
5.6	Mrs. Choi’s Deployment Plan for the Textbook Chapter132
6.1	The Investigation of Students’ Mathematical Background from Mrs. Choi’s Lesson Plan146
6.2	The Investigation of Students’ Mathematical Background from Mr. Bae’s Lesson Plan148
6.3	Mr. Bae’s Lesson Plan’s Objectives149
6.4	The Investigation of Students’ Mathematical Background from Mrs. Choi’s Lesson Plan154
6.6	Mrs. Choi’s Lesson Plan Based on Her Students’ Mathematical Backgrounds157

6.7	The Investigation of Students' Mathematical Background from Mrs. Jeong's Lesson Plan	158
6.8	Mrs. Jeong's Lesson Plan Based on Her Students' Mathematical Backgrounds	160
7.1	Part of Mrs. Lee's Lesson Plan I.....	181
7.2	Part of Mrs. Lee's Lesson Plan II	183
7.3	Part of Mr. Ki's Lesson Plan II.....	186
8.1	Mrs. Kim's Understanding of her Students	212

CHAPTER 1

Introduction

Since the No Child Left Behind Act (NCLB) took effect in 2001, it has had a huge impact on the education field. A major result of NCLB is that student mathematics achievement has been linked to state standards as a means to identify school accountability (Dee & Jacob, 2011). With more emphasis on school accountability for student outcomes, the interest in various factors that might raise student mathematics achievement has increased. Most important, policy makers and national organizations are beginning to take more interest in how teachers might promote students' high academic achievement (U.S. Department of Education, Office of Postsecondary Education & Office of Policy Planning and Innovation, 2002). This challenge is not unique to the U.S. educational system. According to Park's (2010) study, teachers' quality and its impact on students' mathematical achievement has become a global concern as well. In addition, wide-ranging research over the past decades has demonstrated that the diversity in teacher quality might make a huge impact on student achievement (Rice, 2003). In particular, River and Sanders (2002) assert that student achievement in mathematics is affected by mathematics teacher quality. As such, how should we define mathematics teacher quality?

There are studies that attempt to answer this question by examining teachers' knowledge for teaching mathematics. For the last 20 years, there has been an attempt to understand and define what kinds of knowledge elementary teachers should have for effective mathematics instruction (e.g., Ball, Lubienski, & Mewborn, 2001; Bass, 2005; Hill, Schilling, & Ball, 2004; Hill, Blunk, Charalambos, Lewis, Phelps, Sleep, & Ball,

2008; Kahan, Cooper, & Betha, 2003; Kennedy, Ball, & McDiarmid, 1993; Kılıç, 2011; Ma, 1999). Researchers have examined elementary teachers' knowledge for teaching mathematics to identify the effectiveness of mathematics teachers (Hill, Rowan, & Ball, 2005). In addition, recent research confirms that elementary teachers' knowledge for teaching mathematics has a positive influence on student learning of mathematics (Moris, Hibert, & Spitzer, 2009; Hill, Blunk, Charalambos, Lewis, Phelps, Sleep, & Ball, 2008; River & Sanders, 2002; Hill, Rowan, & Ball, 2005). In particular, elementary teachers' knowledge for teaching mathematics is significant because teachers at this level affect younger students' mathematics achievement scores more than those of older students (Hill, 2008; Konstantopoulos, 2011). Thus, because it is viewed that elementary teachers' knowledge for teaching mathematics influences student achievement in mathematics, it is important to study the nature of elementary teachers' knowledge for teaching mathematics. Determining what teachers should know about mathematics instruction may play a significant role in improving the quality of teaching practice, teacher certification, and teacher preparation programs (Ball, Thames, & Phelps, 2008).

However, it is not easy to define teachers' knowledge for teaching mathematics, although the studies presented above named and defined teachers' knowledge in various ways (e.g., knowledge of content or teachers' knowledge of students' mathematical thinking) (Hill, Ball & Schilling, 2008). Teachers' knowledge for teaching mathematics does not simply mean that teachers have knowledge of mathematical content, such as algebra and geometry (Hill, 2008) because teaching is not just delivering procedural information but helping students develop their conceptual understanding (Kılıç, 2011). From this point of view, Albert (2012) asserted that "teachers need to develop not just a

deeper knowledge of subject matter but an understanding of the mathematical process of inquiry to enrich their teaching practices and to encourage critical thinking skill development in their students.” In addition, the Common Core State Standards for Mathematics Initiative (CCSS) also proposes that the teaching of mathematical content needs to emphasize both procedural skills and conceptual understanding to make sure students are learning and absorbing the significant information they need to succeed at higher levels (CCSS, 2010). Therefore, more research in this area needs to be conducted to understand teachers’ knowledge for teaching mathematics, which remains underspecified due to its intricacy, although there have been diverse approaches used to reveal it (Hill, Ball, & Schilling, 2008).

More to the point, the major issue of the current studies is that these studies focus on a couple of categories of elementary teachers’ knowledge for teaching mathematics by applying a framework, which was developed by a few conceptual studies (e.g., Shulman, 1986; Ball, Thames, & Phelps, 2008). Due to the lack of empirical bases, the categories of teachers’ knowledge are not clearly defined (Ball, et al., 2008; Gearhart, 2007), and the relationships among categories are vague (Marks, 1990; Eisenhart, Borko, Underhill, Brown, Jones, & Agard, 2012; Even, 1993). Consequently, the results of the current studies are limited to specific case studies in relatively narrow content areas (Hill, Shilling, & Ball, 2008). An extensive empirical study is needed to develop a concise description of what kinds of knowledge elementary teachers should have for teaching mathematics.

Another issue of current studies about teachers’ knowledge for teaching mathematics is that most studies only focused on pedagogical content knowledge (PCK),

which has been defined by Shulman (1987) as one of the categories of teachers' knowledge for teaching mathematics (1987). PCK indicates pedagogical transformation of mathematics concepts, which considers how mathematics content will be taught and how teachers might understand student learning (Shulman, 1987; An, Kulm, & Wu, 2004). Subsequently, there is a lack of detailed understanding regarding the other categories of teachers' knowledge for teaching mathematics (e.g., knowledge of mathematics curriculum). These studies' inclination may prevent us from fully understanding teachers' knowledge for teaching mathematics. Moreover, there is a lack of empirical evidences about teachers' use of PCK more than the other categories of knowledge for teaching mathematics or that teachers need to know PCK as a priority for effective mathematics instruction. In addition, there are limitations regarding the effects of elementary teachers' PCK for teaching mathematics. While elementary teachers' PCK for teaching mathematics affected most students' mathematics achievement, there was little effect on minority students and students who had received low scores on previous achievement tests (e.g., Hill, 2008; Hill & Ball, 2005; Tanase, 2011).

To broaden the perspectives on elementary teachers' knowledge for teaching mathematics, this study focuses on South Korean elementary schoolteachers. Cai (2001) suggested that international research might provide opportunities to understand diverse issues about teaching and learning mathematics; international research is useful to illustrate diverse mechanisms by which teaching and learning are related and the processes by which students construct meaning from classroom instruction. Therefore, results from international studies might provide some clues for finding missing points about elementary teachers' knowledge for teaching mathematics, although there may not be a huge difference among mathematics itself as a subject from country to country

(Delaney, Ball, Hill, Schilling & Zopf, 2008; Kulm & Li, 2009). For example, from the investigation of Chinese teachers' knowledge for teaching mathematics, Ma (1999) found elementary mathematics teachers' knowledge named "profound understanding of fundamental mathematics," which requires mathematics teachers to be able to "instantiate in the connectedness, multiple perspectives, basic fundamental ideas, and longitudinal coherence" (p. 107). In particular, investigating elementary teachers of South Korea may offer implications for researchers, policy makers, and teachers, especially in the United States, because South Korea's National Mathematics Curriculum was developed based on the U.S. mathematics curriculum standards and is still affected by the U.S. mathematics curriculum standards (Kim, Ham, & Paine, 2011). Further discussion regarding the relationship between South Korea's National Mathematics Curriculum and the U.S. mathematics curriculum standard will be presented in Chapter 4. There might be diverse sociocultural influences on mathematics instruction (Moschkovich, 2002). However, the ways of South Korean elementary teachers applying their knowledge to mathematics instruction based on similar mathematics curriculum standards and content with the United States may offer meaningful perspectives about elementary teachers' knowledge for teaching mathematics in America.

Purpose of the Study and Research Questions

The purpose of this research is to identify the categories of South Korean elementary teachers' knowledge for teaching mathematics. Operating under the assumption that elementary teachers' knowledge for teaching affects students' learning, I chose eleven South Korean elementary teachers to participate in this study.

It does not matter how much mathematical knowledge teachers have if their knowledge does not influence students' learning of the content. Instruction involves more than instances of direct instruction; it also includes all educational interactions between teachers and their students. Therefore, South Korean elementary school teachers' knowledge should be defined in the teachers' practices. Aligned with this purpose, this research seeks to identify the categories of mathematics knowledge for teaching at the elementary level by interviewing 11 South Korean elementary teachers, observing their lessons, and analyzing their lesson plans.

In an attempt to identify the categories of South Korean elementary teachers' knowledge for teaching mathematics, the guiding question for this study was as follows:

What kinds of knowledge for mathematics do South Korean elementary teachers use in their mathematics instruction?

The subquestions of this study are as follows:

1. How does each category of South Korean elementary teachers' knowledge for teaching mathematics influence the teachers' mathematics instruction?
2. How is each category of the South Korean elementary teachers' knowledge for teaching mathematics structured?
3. How does each category of the South Korean elementary teachers' knowledge for teaching mathematics relate to one another?

Each of these subquestions is directly related to the overriding research question; hence, they are examined to uncover the characteristics of the South Korean elementary teachers' knowledge for teaching mathematics.

Framework

Theoretical Orientation

This study assumes that South Korean elementary teachers' language used in the classroom is critical to understanding their knowledge for teaching mathematics. This assumption is grounded in Vygotsky's notion that learning is compatible to adult guidance, especially how teachers use language in the classroom (e.g., Vygotsky, 1978; 1997). According to Vygotsky, teachers' use of language plays a pivotal role in students' intellectual development and their success in learning content because their use of language guides students' mathematics understanding and thinking (Albert, 2012; Chaiklin, 1986). In this case, language does not simply mean just oral expressions but rather anything that teachers use to communicate with and guide students to promote understanding of concepts and skills, such as using materials or drawing models (Albert, 2012).

For example, the equation of $3 + 4 = 7$ might be a meaningless symbol to students. Based on a teacher's verbal explanation about the meaning of the equation or nonverbal expression, students may understand the quantities that each numeral represents as well as the process of addition as shown in Figure 1.1.

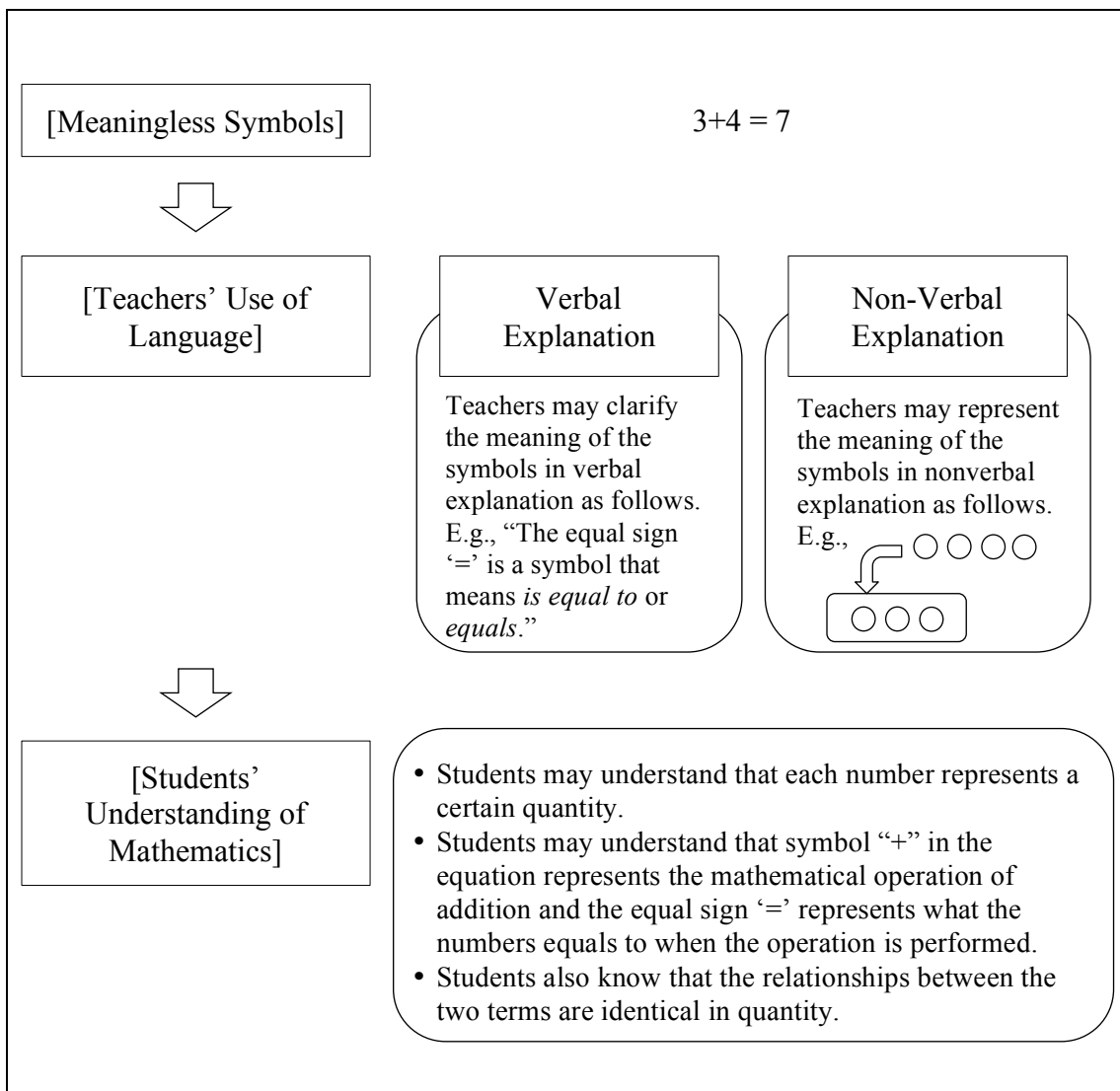

Figure 1.1 Teachers' Role of Languages in Mathematics Instruction

As presented Figure 1.1, the teachers' mathematical language plays a vital role in this process. Teachers may help understand what the equation represents. Teachers also may present representative models that include numeral information to support students' understanding of the equation. In addition, teachers' use of language in a mathematics classroom might differ from their everyday languages because it encompasses explanations of mathematics concepts and procedures based on their instructional purposes. Researchers suggest that the ways of explaining mathematics concepts and procedures and selecting mathematical representations or models reflect the teachers'

knowledge of mathematics content and pedagogical transformation of it (Stylianides & Ball, 2008; Ball, Thames, & Phelps, 2008).

Because it is viewed that teachers' use of language is key to students' understanding of mathematics, and the mirroring of teachers' knowledge regarding mathematics instruction, this study focused on teachers' use of language in their teaching practices rather than on developing a questionnaire to assess the teachers' knowledge for teaching mathematics (e.g., Hill, Schilling & Ball, 2004; Dalaney, Ball, Hill, Schiling, & Zopf, 2008) or investigating students' outcomes (e.g., Hill, Rowan, & Ball, 2005; Tanase, 2011).

Conceptual Framework

Although this study assumes that the teachers' use of language in their mathematics instruction is key to understanding their knowledge, there are still remaining questions for designing this study. What is the range of teaching practices that are affected by teachers' knowledge for teaching mathematics? Should this study only focus on teachers' teaching in a mathematics classroom in order to define South Korean elementary teachers' knowledge for teaching mathematics? Alternatively, what kind of information about the teachers should I check for to conduct an in-depth analysis of their knowledge? Are there any significant aspects of teachers' knowledge for teaching to consider when choosing participants for this study?

To address these questions and others that might emerge during the course of this study, a conceptual framework was developed from the review of the literature of this study (See Figure 1.2). This framework attempts to account for diverse viewpoints regarding the range of teaching practices and components that might affect teachers'

knowledge for teaching based on the literature review, which will be discussed in Chapter 2.

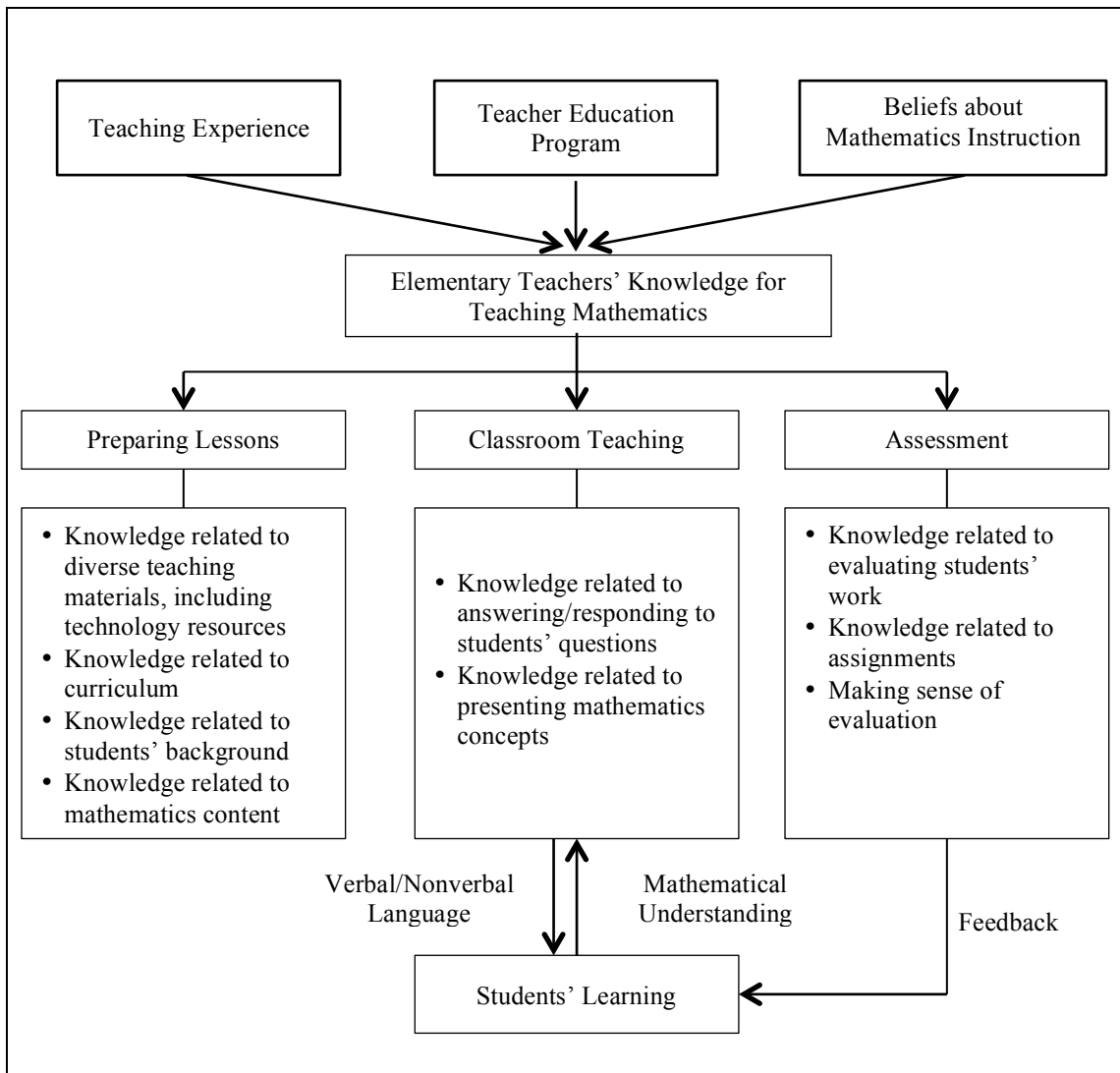

Figure 1.2 The Conceptual Framework

As illustrated in the conceptual framework, recent studies suggest that the factors that affect elementary teachers' knowledge for teaching mathematics are teaching experience, the teacher education program, and their beliefs about mathematics instruction (e.g., Bell & Wilson, 2010; Fennema & Franke, 1992; Hill, 2008; Bell, Wilson, Higgins, & McCoach, 2010). Therefore, for this study, these factors were used to select participants and then as a tool for analyzing their knowledge for teaching

mathematics. The process of selecting participants will be discussed in Chapter 3, and the results of the analysis will be presented from Chapters 5 to Chapter 8.

Regarding the perspectives on the teachers' knowledge, this study assumed that internal representations such as mathematical ideas, facts, or procedures might be connected to one another in useful ways according to the cognitive science (Hiebert & Carpenter, 1992). To understand the characteristics of categories of teachers' knowledge for teaching mathematics and to reveal the relationship according to the subquestions of the study, this study focused on these connections among diverse categories of teachers' knowledge for teaching mathematics.

In addition, the teaching process, which is affected by elementary teachers' knowledge for teaching mathematics, consists of developing the instructional process (e.g., Stylianides & Ball, 2008; Ball, Thames, & Phelps, 2008), classroom teaching (e.g., Turner, 2008; Izsa'k, 2006; Polly, 2011), and assessing students' work (e.g., Empson & Junk, 2004; Anderson & Kim, 2003; Kleve, 2010). The detailed explanation of each instructional process will be discussed in Chapter 2. The conceptual framework regarding the range of teaching processes guided the diverse aspects of this study. According to these three stages of the teaching process, data were collected and analyzed. The detailed process of collecting data and analysis will be presented in Chapter 3.

Importance of Study

The issues of mathematics teachers' accountability have been raised to new heights as the No Child Left Behind Act became implemented (Scher & O'Reilly, 2009). Therefore, the attention to teaching accountability is more apparent in the areas of mathematics where schools face significant difficulties filling vacancies with qualified

teachers (Scher & O'Reilly, 2009). Not only in the United States, but also in many countries, careful consideration of effective mathematics teaching is evident (e.g., Conference Board of the Mathematical Sciences, 2001). As the interest in the qualification of teachers has increased, recent research studies have revealed that teachers' knowledge for teaching mathematics influences students' learning of mathematics (e.g., Ma, 1999; Moris, Hibert, & Spitzer, 2009; Hill & Ball, 2005; Hill, Blunk, Charalambos, Lewis, Phelps, Sleep, & Ball, 2008; Morris, Hibert, & Spitzer, 2009; River & Sanders 2002; Hill, Rowan, & Ball, 2005).

Those interests in the teachers' teaching ability led to concerns about the kinds of knowledge that effective mathematics teachers should have, including teachers at the elementary level. However, there are not many diverse perspectives on teachers' knowledge even in research on mathematics education at the elementary level, although there needs to be more careful approaches taken toward elementary teachers' knowledge. The basic concepts of mathematics are introduced to students during their elementary school grades. In addition, due to the hierarchal nature of mathematics, if a student is unable to acquire the concepts from previous steps, it may cause more severe difficulties with learning concepts at a higher level.

The goal of this study is to identify the categories of South Korean elementary teachers' knowledge for teaching mathematics. As noted previously, recent studies have focused on understanding elementary teachers' knowledge for teaching mathematics. Although this study refers to previous studies about teachers' knowledge for teaching, this study did not apply previous frameworks regarding subcategories of teachers' knowledge in order to seek hidden aspects of elementary teachers' knowledge for

teaching mathematics with empirical data. Therefore, this study sought to broaden the perspectives toward the categories of elementary teachers' knowledge for teaching and provide a clear evidence for each knowledge category.

Another contribution of this study is that it will highlight the elementary teachers' practical use of their knowledge for teaching mathematics in their classrooms.

Specifically, this study analyzed eleven elementary teachers' teaching and lesson plans and conducted extensive interviews with them in order to obtain empirical evidence for the categories of South Korean elementary teachers' knowledge for teaching mathematics and how this knowledge affects their teaching. The results of the data analysis in this study are expected to provide some clues to define categories of teachers' knowledge for teaching mathematics, which remain unclear from the previous studies (e.g., Ball, et al., 2008; Even, 1993).

Teachers may not automatically know how to change their teaching to be effective mathematics instructors (Kilpatrick, Swafford, & Findell, 2001). Therefore, it is important to investigate what kinds of knowledge teachers should have to improve their instruction as well as to understand the kinds of knowledge that teachers use in their teaching practice. The investigation of South Korean elementary teachers' knowledge for teaching mathematics may offer new perspectives on teachers' knowledge for improving mathematics instruction in the United States. It does not mean that South Korean elementary teachers have better knowledge for teaching mathematics than U.S. teachers do. The implication of this study is to provide food for thought for elementary teachers' knowledge for teaching mathematics and even mathematics education itself in the United States.

Significant changes in the research area of teachers' knowledge or elementary mathematics education can never be brought about by the results of a single study. However, this study is expected to contribute to increased attention toward elementary teachers' knowledge for teaching, which could improve the quality of mathematics instruction. In addition, it will contribute to the global discussion about teacher effectiveness and teacher quality.

Definition of Terms

For the purpose of this study, four key terms are defined to clarify and understand the research perspective: instrumental understanding, relational understanding, top-down approach, and bottom-up approach. This study assumed that instruction indicates interaction between teacher and students. In this sense, I used the terms that related to mathematics instruction, including learning and teaching.

Regarding students' mathematics learning, I used the terms, *instrumental understanding* and *relational understanding* from Skemp's (1989, p. 2) study of how students understand mathematics to describe how elementary teachers' knowledge for teaching mathematics interacts with students' understanding of mathematics. Skemp (1989) emphasizes the learner's own knowledge structures (schema); Skemp insists that teachers should find efficient ways of replacing or developing schema with new mathematics concepts. Regarding the learner's schema, Skemp divides students' understanding into two aspects: relational understanding and instrumental understanding (Skemp, 1989). Relational understanding indicates that students understand what procedures to use to solve a problem as well as why those procedures work, including how they connect to other concepts; whereas, instrumental understanding illustrates that

students only know the procedures for solving a mathematical problem without understanding why those procedures work.

Recent research reveals that teachers should support students' mathematical understanding by providing instruction that offers opportunities to connect mathematical ideas. For example, Carpenter and Lehrer (1999, p. 20) explained that instruction should be designed so that students build connections by proposing five forms of mental activities from which mathematical understanding emerges: *constructing relationship*, *expanding and applying mathematical knowledge*, *reflecting about experiences*, *articulating what one knows*, and *making mathematical knowledge one's own*. With this stream, Hiebert and Carpenter (1992) presented more systemic teaching approaches that lead students' learning with understanding in mathematics named the *bottom-up approach* and the *top-down approach* (p. 81).

The former, the bottom-up approach, indicates the way to focus on making connections with students' prior knowledge. Students acquire substantial knowledge of mathematics outside of school. In addition, they can apply their prior knowledge to solving a variety of problems in everyday situations, and this provides a potential starting place for instruction to build on students' prior knowledge, ultimately integrated into a fully developed network including the concepts, procedures, and symbols in school mathematics. In this way, case symbols may be introduced as ways of representing knowledge the students already had. For example, when teachers help students understand that $3 \div 4$ can be represented as $\frac{3}{4}$, teachers may use students' prior experiences that relate to indivisible division in the range of natural numbers. Outside of a school, students may have experiences with division of continuous quantities such as

dividing an apple or a pizza equally. Students also may experience dividing discrete quantities such as dividing three dollars equally with four people. Teachers may develop instruction that focuses on connections derived from the students' problem context. During instruction, students may discuss the similarities or differences between division of continuous quantities and division of discrete quantities.

An alternative methodology is a top-down approach. This approach represents how knowledge is potentially structured as a result of instruction. A powerful aspect of mathematics resides in the fact that a number of seemingly diverse situations can be represented externally by the same mathematical symbols; students learn to relate the problem to the number sentence by analyzing the problem. The analysis provides a unifying framework for connecting numbers from difference situations. Consider, for example, the following problem:

A car has four wheels. There are five cars. How many wheels are there?

The problem above would be represented by the number sentence $4 \times 5 =$. Students may develop the concept of multiplication through the repeated addition model. The repeated addition model provides a unifying framework for connecting numbers from different situations. For instance, students may use a number sentence in order to solve problems that include multiplication of fractions or decimals as well as division. In this case, the set of an equal number analysis provides the schema into which almost all multiplication and division problems are mapped. This analysis is based on a top-down perspective; it is an efficient way that skilled problem solvers can analyze multiplication and division situations. This instructional approach, essentially, is to teach directly the schemata that

skilled performers use to organize their knowledge. From the start, then, instruction focuses on long-range goals.

In addition to the four key terms, there are words I use throughout this dissertation to consistently discuss the aspect of South Korean elementary teachers' knowledge for teaching. For example, I used the word *category* to present the types of teachers' knowledge for teaching mathematics. There are studies that use the term *domain* or *subdomain* to illustrate the subordinate relationship among types of knowledge for teaching mathematics (e.g., Ball, Thames & Phelps, 2008). So as not to bias this study, I used the term *category* instead of *domain* or *subdomain* except in the cases in which researchers use the term *domain* or *subdomain* in their studies.

The word *curriculum* refers to a way of organizing mathematics topics to support students' learning (Donovan & Bransford, 2005). The specific meaning of curriculum will be presented in Chapter 5. In addition, *Pedagogical Content Knowledge* indicates knowledge of transforming content into forms that are adaptive to the variations in ability and background presented by the students. The detailed meaning of Pedagogical Content Knowledge will be discussed in Chapter 2. *Concepts* imply the component of thoughts, which enable the individual to categorize, infer, memorize, and learn. Concepts are mental representations that exist in the brain and mediate between thought, language, and referents (Margolis & Laurence, 1999). Further explanation of how concept is used in this study is discussed in Chapter 7.

Overview of the Chapters

This study will consist of nine chapters. This chapter presents an overview of the study. It framed the research questions as well as the importance of the study and its

rationale. Chapter 2 includes a review of literature related to sociocultural theory, which served as the lens for the process of collecting and analyzing data in this study. Chapter 2 also contains a review of the literature about elementary teachers' knowledge for teaching mathematics and provides a historical background for the research. Chapter 3 outlines the qualitative research approach used in this study, which draws on case study methods. Chapter 4 provides the social context of the education system in South Korea. Chapters 5, 6, 7 and 8 present the findings of the study, which offer a theoretical model of South Korean elementary teachers' knowledge for teaching mathematics. Each finding chapter illustrates one or two categories of the South Korean elementary teachers' knowledge for teaching mathematics that emerged from the results of the analysis of the data. Chapter 9 summarizes and discusses the findings of this study and provides implications, limitations, and possible directions for future research.

CHAPTER 2

Review of the Literature

Many approaches that used diverse research methods discussed in the literature reveal teachers' knowledge for teaching mathematics at different grade levels (e.g., Andelfinger, 1981; Even & Markovits, 1991; Klein & Tirosh, 1997; Chapman, 2004). However, due to the lack of empirical data for the categories of elementary teachers' knowledge for teaching mathematics, the categories of teachers' knowledge for teaching mathematics at the elementary level and their relations have not been clearly specified.

This review of literature is a critical examination of conceptual and empirical studies in the area of elementary teachers' knowledge for teaching mathematics; it includes a discussion of the implications and implementations emerging from the review. The literature review is divided into four major sections: sociocultural theory, a history of research on teachers' knowledge for teaching mathematics, studies on elementary teachers' knowledge for teaching mathematics, and an interpretive summary and critical analysis. The first section is a discussion of sociocultural theory as the lens for this study. This section includes a review of major conceptual arguments and a sample of empirical studies in which sociocultural theory is the focus. The second section presents the historical context of teachers' knowledge for teaching mathematics. To illustrate the influence of the research about mathematical knowledge for teaching on teaching practices, a review of major conceptual studies and examples of empirical studies are examined. The third section is a descriptive analysis of literature about elementary teachers' knowledge for teaching. In this section, empirical studies are categorized based on their respective research questions. Taken together, these three sections of literature

provide a historical and theoretical context for this study. The final section summarizes the findings of the research and locates the research question for this study within the context of the related literature.

Sociocultural Theory

Sociocultural perspectives focus on social interaction and cultural organization that influence psychological development of students. However, it is not just that the child learns from others in social contexts and during social exchange, but rather that the actual means of social interaction are appropriated by the individual to form the intramental tools for higher-level thinking (Wertsch, 1985a).

Vygotsky laid the foundation for sociocultural theory, as he emphasized students' learning through social interactions (Albert, 2012). In particular, Vygotsky placed more emphasis on the role of communication as a means of social interaction in student learning for all kinds of subjects (Albert, 2012; Chaiklin, 1986). Teachers' use of language should guide students' creative and critical thinking and lead them to the next learning level (Vygotsky, 1978). In this case, language does not simply mean just oral expressions but rather anything that teachers use for communicating and guiding students to promote understanding of concepts and skills (e.g., classroom materials or drawing models). The significant role of communication is also highlighted in mathematics education. Hiebert, Fennema, Fuson, Wearne, Murray, Olivier, & Human (1998) suggest that communication is the key for developing students' mathematical understanding. The National Council of Teachers of Mathematics (NCTM) (2000) also identified the significance of communication in the learning of mathematics suggesting, "ideas become

objects of reflection, refinement, discussion, and amendment through communication” (p. 60).

For mathematics learning, teachers may use communication to create students’ zone of proximal development (ZPD), which is another idea espoused by Vygotsky’s sociocultural theory (Steele, 2001). The ZPD is “the distance between the actual developmental level as determined by independent problem solving and the level of potential development as determined through problem solving under adult guidance or in collaboration with more capable peers” (Vygotsky, 1978, p. 86). Based on the concepts of the ZPD, teachers may assist a student in further learning by providing familiar information to assimilate with students’ present knowledge (Bruner, 1986). The implication of the ZPD is that a student is able to learn new skills that go beyond the student’s actual development. That is, development follows the student’s potential to learn (Vygotsky, 1978). In addition, sociocultural theory perceives students’ mathematical background as a resource for their learning (Moschovich, 2002). Therefore, a teacher should acknowledge students’ mathematical background that includes conceptual and procedural mathematical understanding and build new knowledge based on it.

Within the ZPD, which is created through communication and interaction with others, students should *internalize* the new skills individually (Vygotsky, 1997). To demonstrate the process of adopting new skills as *internalization*, Vygotsky argues, “Any function in the child's cultural development appears twice or on two planes. First it appears on the social plane, and then on the psychological plane. First it appears between people as an interpsychological category, and then within the child as an

intrapsychological category” (p.163). Vygotsky perceives a separate but related relationship between external social planes and internal psychological planes. However, external and internal processes are not duplicates of one another (Wertsch, 1985b). Internalization transforms the external process into the internal, consequently changing both the structure and functions of the process (Vygotsky, 1981). Moreover, social interaction plays a pivotal role in determining the nature of internalization. Internalization involves a concept that children’s understanding of others is developmentally rooted in their experience of social interaction (Fernyhough, 2008).

By adopting sociocultural theory as a framework, I operated under several assumptions. It is explicitly viewed that teachers’ use of language play a pivotal role in students’ mathematical understanding and their success in learning mathematics. In this case, all forms of communication applied in the classroom can mediate student thinking and understanding of the mathematics content. Therefore, a major purpose of the study is to understand elementary teachers’ knowledge for teaching mathematics by analyzing the teachers’ communication during the lessons by observing their teaching. In addition, sociocultural theory views the social context as a significant aspect of learning. Thus, the teachers’ classroom environment is the social context, and their language is a key in constructing the social context that may influence students’ internalization of mathematical concepts and skills. Consequently, this study considered how teachers create various social contexts for students to learn mathematics concepts. Teachers’ pedagogical intentions for developing learning contexts will be investigated through observations, interviews, and analysis of their lesson plans. To examine the learning context influences on students’ internalization of mathematical concepts, these data

sources are connected to the social contexts that the teachers construct for their students. Taken together, sociocultural theory offered a holistic perspective on the relationship between elementary teachers' knowledge for teaching mathematics and teachers' use of communication for supporting students' development of mathematical understanding.

History of Research on Teachers' Knowledge for Teaching Mathematics

An important aspect for understanding the importance of sociocultural theory relation to this study is to consider the history of teachers' knowledge for teaching mathematics. First, this section examines the historical context concerning the research on teachers' knowledge for teaching mathematics. Second, this discussion includes an exploration of the categories of teachers' knowledge for teaching mathematics. Also, it will be essential to briefly examine reform in South Korea mathematics education because it serves as the larger sociocultural context for this present study.

Research on Teachers' Knowledge for Teaching Mathematics

The arrival of the common school in the 1830s in the United States initiated a process of simplifying a wide variety of educational settings and generated a demand for highly qualified teachers (Labaree, 2008). Expanding public education, and *The Equality of Educational Opportunity Study* (EEOS) in 1966, conducted in response to provisions of the Civil Rights Act of 1964, marked a watershed in studies on teacher quality (Lagemann, 2000). This report, also known as the Coleman Study, was about educational equality in the United States, and had more than 650,000 students in the sample (Borman & Dowling, 2010). According to this report, teachers were significant in determining educational outcomes as were students' backgrounds and socioeconomic status rather than school resources such as school funding (Coleman, J. S., Campbell, E. Q., Hobson,

C. J., McPartland, J., Mood, A. M., Weinfeld, F. D., et al., 1966). After the EEOS was released, studies based on observation of classroom processes and reliable measures of student achievement began to appear and to increase in the late 1960s and 1970s (Needels, 1988). Shulman (1986) named this stream the process-product paradigm. Borphy and Good stated that this paradigm has enhanced our understanding of teaching greatly and provoked debate about school effects (Hanushek, 1998).

In mathematics education, the emphasis on teacher quality arose with a focus on the process-product paradigm. In particular, *A Nation at Risk* (The National Committee of Excellence in Education, 1983), which revealed the steady decline in student academic achievement scores, stated that “not enough of the academically able students are being attracted to teaching; that teacher preparation programs need substantial improvement” (p. 20). In the same vein, *The Underachieving Curriculum* (McKnight, Crosswhite, Dossey, Kifer, Swafford, Travers, & Cooney, 1987), which analyzed U.S. performance on the Second International Mathematics Study (SIMS), emphasized that “professional development programs for mathematics teachers must be improved” (p. 115). The claims highlighted in both of these documents were supported by research findings; studies found that there are positive influences on what teachers know regarding how they teach (Darling Hammond, 2000). That is, one of the most significant factors that influence teachers’ quality is their knowledge for teaching.

Considering this perspective, the National Council of Teachers of Mathematics (NCTM) published the *Curriculum and Evaluation Standards for School Mathematics* in 1989 and *Professional Standards for Teaching Mathematics* in 1991 in response to *A Nation at Risk* and *The Underachieving Curriculum*. The professional standards for

teaching mathematics highlight mathematics teachers' knowledge by "present[ing] a vision of what teaching should entail to support the changes in curriculum set out in the *Curriculum and Evaluation Standards*. This document spells out what teachers need to know to teach toward new goals for mathematics education and how teaching should be evaluated for the purpose of improvement" (NCTM, 1991, p. vii).

In 2000, NCTM published *Principles and Standards for School Mathematics*. This document updated the *Curriculum and Evaluation Standards for School Mathematics* and includes *Professional Standards for Teaching Mathematics* and *Assessment Standards for Teaching Mathematics*. According to these *Standards*, teachers are required to be well prepared to teach mathematics (NCTM, 2000). The *Standards* provides outlines for teachers' knowledge for teaching mathematics as well as general goals for PreK–12 mathematics education. Specifically, the *Standards* describe a set of principles that defines what teachers should know in order to teach mathematics; teachers are required to know and understand mathematics, students as learners, and pedagogical strategies as well as how to challenge and support the classroom learning environment (pp. 17–19). In addition, the *Standards* propose "teachers need to know and use mathematics for teaching that combines mathematical knowledge and pedagogical knowledge ... they must continue to learn new or additional mathematics content and study how students learn mathematics" (NCTM, 2000, p. 370). This vision highlights the significance of teachers' knowledge for teaching and suggests teachers begin to view themselves as lifelong learners (Graham, 2001).

During this same time, the No Child Left Behind Act (NCLB, 2001) was passed. It required schools' and teachers' accountability for student academic achievement in

reading/language arts and mathematics. Schools were required to present *adequate yearly progress* (AYP) in state standardized test scores. Therefore, a major effect of NCLB is linking student mathematics achievement to state standards to identify school failing (Dee & Jacob, 2011). For this reason, policy makers and national organizations focused more on how teachers might help promote students' high academic achievement (U.S. Department of Education, Office of Postsecondary Education & Office of Policy Planning and Innovation, 2002).

The Common Core State Standards (CCSS) released in 2010 was developed to narrow the discrepancy among content guidelines between states in the area of English language arts and mathematics. The CCSS is poised to be widely adopted and to become entrenched in state education policy (Porter, McMaken, Hwang & Yang, 2012). The CCSS intended to influence the assessment and implementation of the curricula. At the same time, the CCSS also proposes that mathematics teachers are required to know both procedural skills and conceptual understanding "to make sure students are learning and absorbing the critical information they need to succeed at higher levels" (CCSS, 2010). That is, teachers need to develop not just a deeper knowledge of mathematics content but also an understanding of the mathematical process of inquiry and problem solving to enrich their teaching practices and to encourage critical thinking skill development in their students (Albert, 2012). This emphasis on mathematics teachers' quality is not unique to the U. S. education system. Teachers' efforts to improve student mathematical achievement have become a global concern (Park, 2010).

As noted above, diverse studies reveal that teacher quality in education ultimately determines the success or failure of school education, and this is the reason every

document focusing on standards mentions teachers' knowledge or understanding of mathematics in the new standards. The significance of teachers' mathematics knowledge for teaching has been emphasized along with the importance of teacher quality in education. Mathematics teachers' knowledge of what constitutes good mathematics instruction poses a great influence on the type of mathematics pedagogy teachers will deliver in their own classrooms (Hill, 2004).

Historical Context of Research on Teachers' Knowledge for Teaching Mathematics in South Korea

The emphasis on mathematics teachers' quality is not unique to the U. S. education system. In addition, teachers' effort to improve student mathematical achievement has become a global concern, including in South Korea (Park, 2010). As noted previously, the South Korean government's laws have led the reform movement on teachers' quality in South Korea rather than research or standards. Thus, this section concentrates on major reforms and laws regarding teachers' quality in order to provide a broader understanding of the social context of South Korea. In particular, this section focuses primarily on elementary education and not secondary education because the purpose of this study is on elementary schoolteachers' knowledge for teaching mathematics. The examination of national concerns about South Korean teachers' quality may provide insights into how to apply the findings regarding improving the quality of elementary mathematics teachers in South Korea.

South Korea was an absolute monarchy until Korea was annexed by Japan in 1910. After Japan invaded Korea, Japan established a modern education system in Korea based on colonial education. At that time, modern schools were founded, and the

education system was controlled by Japan. However, this period cannot be regarded as the beginning of modern education in Korea. Although the surface of the education system was modernized, the inner side of the education system was still despotic. After its liberation from the Japanese in 1945, the South Korean government required 6 years of compulsory elementary schooling according to *the education law*, which was enacted in 1949. However, the efforts to establish a modernized education system had not succeeded in South Korea until 1954, due to the outbreak of 1950–1953 Korean War. In 1954, the South Korean government announced *a six-year plan for accomplishing compulsory schooling*, including mathematics education, which aimed to increase school attendance of students and to secure the infrastructure for the education system. After the plan was enacted, the educational demand to teach children rapidly increased in South Korea, which inevitably increased the need for more teachers. In the 1950s, the South Korean government administrated twenty-four *provisional elementary teacher training schools*, which provided a 2-month elementary teacher certification program. With the certification, elementary teachers were eligible to teach all kinds of subjects in public schools.

In the 1960s, after balancing the supply with demand for elementary teachers, the South Korean government became interested in the quality of the elementary teachers in terms of their knowledge. The government believed that teachers' knowledge for teaching was a significant factor in the quality of instruction and concluded that a 2-month training program for teachers was insufficient (The Ministry of Education in South Korea, 2013). Based on *the Special Act on Education* in 1961, the government established 16 specialized universities, which provided a 2-year elementary teacher

certification program. The specialized universities offered curriculum that focused on knowledge elementary teachers should have in order to teach at the elementary level, including educational theories, teaching methods for each subject, and student development.

However, the demands set for high-quality elementary teachers have been part of an ongoing process. Thus, the government expanded the years of the elementary teacher education program from 2 to 4 years according to *the Revised Education law* in 1981. Preservice teachers must earn 140 credits in order to acquire elementary teacher certification from one of the specialized universities, including five credits related to elementary mathematics education (Seoul National University of Education, 2012). Over time, based on the decreasing demand for teachers, the numbers of specialized universities preparing elementary teachers decreased from 16 to 11, and this number is current today.

The effort of the government to prepare highly qualified elementary teachers who have in-depth knowledge for teaching also affected the teacher recruitment system in South Korea. *The Comprehensive Plan for Elementary and Secondary Teachers*, which was suggested by *the Advisory Committee of Educational Policy* in 1988, included policies for improving the teacher certification program and recruitment system. Until 1990, preservice teachers who had an elementary teacher certification could work in a public school without taking a national exam. However, the government revised the education law regarding the teacher recruitment system in 1990; to become an elementary teacher in a public school, preservice teachers who acquired their teacher certification from a specialized university must also pass *the national examination*.

In 1995, the government turned its attention from the quality of preservice teacher education programs to inservice teacher education programs by announcing *the Educational Reform Plan*, which included plans for improving inservice teachers' knowledge for teaching. The plan called for reinforcing inservice teacher education programs and supporting professional development that allowed inservice teachers to conduct educational research. For example, inservice teachers may conduct their own research during the school year as individuals or as a group, and the government provides financial support based on the research plan. The government provided diverse inservice teacher education professional development programs, and elementary teachers in South Korea were encouraged to participate in professional development activities or programs for at least 60 hours per year. The government's support for elementary teachers to research educational phenomena and new teaching methods also was critical to improving teachers' knowledge for teaching. Therefore, there are diverse ways for elementary teachers to participate in educational research in South Korea (e.g., research schools, teacher research teams). In addition, the government allowed the specialized universities to offer master's degree programs, which focused on each subject in elementary education such as *elementary mathematics education master's program* in order to improve teacher professionalism based on the 1996 plan. The master's program was designed for inservice teachers to become specialists in each subject. Starting in 2013, the specialized universities began to offer doctorate programs, which also focused on each subject taught in elementary education.

Although the South Korean government did not enact specific laws or regulations regarding the quality of elementary mathematics teachers, the government regulated

general teachers' quality including their ability to provide excellent mathematics instruction. In addition, despite the lack of studies regarding teachers' knowledge for teaching mathematics in South Korea, the South Korean government provides pre- and inservice elementary level programs in order to improve teachers' knowledge for teaching.

In both countries (America and South Korea), high expectations are being placed on teachers' knowledge. Thus, the findings of this study may provide meaningful implications to both countries. In particular, each country has its own strengths and weaknesses in terms of teachers' knowledge. Although the United States has advanced many research studies on how to improve teachers' knowledge for teaching mathematics, the South Korean government might have a more practical system for improving teachers' knowledge such as specialized degree programs at elementary level and support systems for teachers' research than does the United States. Thus, studying South Korean elementary teachers' knowledge for teaching mathematics, with the research resources in America, may provide an opportunity to inform the preparation and professional development of elementary teachers in both countries.

Research on Teachers' Knowledge for Teaching Mathematics

In the previous section, this review examined the historical context regarding research on teachers' knowledge for teaching mathematics to understand the significant of this study. To obtain perspective about elementary teachers' knowledge for teaching, this section investigates the major conceptual studies and the empirical research about elementary teachers' knowledge for teaching mathematics. The discussion in this section may help develop an overall understanding of elementary teachers' knowledge for

teaching mathematics. To select studies to review, this review of literature set the criteria for inclusion as follows.

First, to focus on elementary teachers' knowledge for teaching mathematics, I eliminated studies that compared elementary teachers' knowledge for teaching mathematics with secondary teachers' knowledge for teaching mathematics and studies that were conducted without distinction between elementary mathematics and secondary mathematics. Also, studies that looked at preservice elementary teachers were excluded because elementary teachers' knowledge for teaching mathematics might be related to their teaching experiences (e.g., Bell & Wilson, 2010).

Second, the first selection process for this review limits its scope to empirical studies because one of the goals of this review is to provide some implications for conducting this research. One of the major assumptions of this study is that teachers' knowledge for teaching mathematics should be understood in regard to teaching practices. Empirical evidence might be more important than theories are when it comes to understanding teachers' application of their knowledge of mathematics instruction.

Third, the range of the time period is limited from 2001 to 2012. That is, the present review only focuses on the studies that were conducted after the passing of the NCLB act. As noted in the previous section, teachers' knowledge for teaching mathematics has been researched as a major factor that affects the quality of mathematics instruction since the arrival of the common school in the 1830s in the United States. However, current studies report that the release of the NCLB act may have affected teachers' knowledge for teaching mathematics (e.g., Selwyn, 2007; Hill & Barth, 2004;

Desimone, 2009). In addition, this limitation related to current educational interest might offer more direct and practical clues to a pending issue for researchers.

Based on these criteria, three electronic databases were searched between the years of 2001–2012: the Proquest Education Journal, ERIC (EBSCO) and JSTOR. Search parameters for the review were identified by initially focusing on a set of keywords to search the educational databases, including elementary teacher knowledge and mathematics, elementary teacher content knowledge, and mathematics and Pedagogical Content Knowledge and mathematics. Studies that were presented as conference papers and dissertations were excluded for practical reasons; studies presented as conference papers may be incomplete, and it is difficult to evaluate the methodological quality of the researchers for dissertation studies, as they might not be peer reviewed in the same fashion as are published journal articles (Conn, Valentine, Copper & Rantz, 2003). At the time of this review, twenty empirical studies satisfied the criteria, including international studies.

Afterward, to select conceptual studies for this review, I analyzed the conceptual frameworks of the twenty empirical studies, which were selected based on the criteria presented above. This review found that the empirical studies cited the other conceptual studies to define categories of elementary teachers' knowledge for teaching mathematics for the study. For example, Anderson and Kim (2003) developed the conceptual framework based on the categories of teachers' knowledge, which were defined by Shulman (1987), whereas Bell, Wilson, Higgins, and McCoach (2010) conducted their research based on Ball, Thames, and Phelps's (2008) definition of domains of teachers' knowledge for teaching. From the analysis, this review found there were four conceptual

studies that were cited most often by researchers (Shulman, 1987; Fennema & Franke, 1992; Ball, Thames, & Phelps, 2008; Mishra & Koehler, 2006).

Although this review selected empirical studies first and chose conceptual studies based on the analysis of empirical studies next, for practical purposes, this section will present the review of the conceptual studies first and then the empirical studies. It might be feasible to present research on categories of teachers' knowledge in order to understand empirical studies that focused on each of the categories.

Conceptual Studies on Categories of Teachers' Knowledge for Teaching

Mathematics

For all the significance of teachers' knowledge for teaching mathematics, there are not many discussions about categories of teachers' knowledge for teaching mathematics. While the characteristics of the general knowledge needed for teaching was regarded, "A body that encompasses both knowledge of general pedagogical principles and skills and knowledge of the subject matter to be taught" traditionally is needed (Grossman & Richert, 1988, p. 54). For the last two decades, most studies have focused on teachers' transformation of mathematics concepts or on teachers' decision-making methods used in a mathematics classroom (Ponde & Chapman, 2007). However, the purpose of this study is to seek the categories and their relationships to South Korean elementary teachers' knowledge for teaching mathematics. Therefore, this section focuses on the studies on the categories or domains of teachers' knowledge. This section also encompasses a study that does not focus on mathematics teachers in order to provide a broad understanding of teachers' knowledge (e.g., Shulman, 1986).

Shulman's Research on Teachers' Knowledge for Teaching

In 1986, Shulman provided a framework for teachers' knowledge for teaching, and his notion has remained mostly unchanged despite the increasing number of studies on teachers' knowledge for teaching (e.g., Bullough, 2001; Kinach, 2002; Segall, 2004). It has had a huge effect on the understanding categories of teachers' knowledge for teaching mathematics, although Shulman did not specify categories of teacher knowledge for teaching mathematics (e.g., Ball, Thames & Phelps, 2008; Rowland, Huckstep & Thwaites, 2005; Eisenhart, Borko, Underhill, Brown, Jones & Agard, 1993). Shulman's key categories of teachers' knowledge for teaching are presented in Figure 2.1.

- | |
|--|
| <ul style="list-style-type: none"> • General pedagogical knowledge • Knowledge of learners • Knowledge of education context • Knowledge of educational, philosophical and historical grounds • Content knowledge • Curriculum knowledge • Pedagogical Content Knowledge |
|--|

Figure 2.1. Shulman's Key Categories of Teachers' Knowledge

General pedagogical knowledge indicates pedagogy in general regardless of the content knowledge teachers are to be specialized in (Shulman, 1987). This category empowers teachers to be aware of the educational system as a whole with a focused comprehension of their students through research in psychology and pedagogy (Richards & Farrell, 2005).

Knowledge of learners demonstrates that teachers have a specific understanding of the learners' characteristics and how these characteristics can be used to specialize and adjust instruction (Shulman, 1987). According to Rahman, Scaife, Yahya, and Jalil (2010), knowledge of learners consists of empirical and cognitive knowledge of learners;

empirical or social knowledge is knowledge of children of a particular age range, and cognitive knowledge demonstrates understanding of child development. Possessing knowledge of learners indicates that teachers understand skills and processes for adapting activities and representations to meet the needs of particular learners, including differentiation for diverse abilities. Effective teachers make successful decisions during the instruction based on their understanding of learners (Wiseman, Cooner, & Knight, 1999).

Knowledge of educational context encompasses teachers' knowledge of how sociocultural and institutional contexts affect learning and teaching, and thus teachers need to know what appropriates in one educational system (Shulman, 1987). Barnett and Hodson (2000) asserted that internal and external sources consist of knowledge of educational context. They argue, "Internal sources include reflection on personal experiences of teaching, including feelings about responses of students, parents and other teachers to one's reaction; external sources include Subject Matter Knowledge, governmental regulation, school policies, and the like" (p. 436).

Knowledge of educational, philosophical, and historical grounds provides the foundation for accumulating knowledge for teaching (Shulman, 1987). Shulman offered this example: "He or she [English teacher] should be familiar with the critical literature that applies to particular novels or epics that are under discussion in class. Moreover, the teacher should understand alternative theories of interpretations and criticism, and how these might relate to issues of curriculum and of teaching" (p. 9). In this case, educational, philosophical, and historical grounds offer a method or activity of analysis and clarification of knowledge (Hardie, 1942).

Content knowledge includes knowledge of the subject and its organizing structures (Grossman, Wilson, & Shulman, 1989; Wilson, Shulman, & Richert, 1987). Specifically, content knowledge comprises substantive and syntactic knowledge (Shulman, 1987). Substantive knowledge can be characterized as knowledge of facts and concepts and the ways that they are organized, while syntactic knowledge is about the nature of inquiry in the field and the mechanisms through which new knowledge is introduced and accepted in that community (Schwab, 1965). In other words, content knowledge encompasses structure knowledge, which indicates the theories, principles, and concepts of a particular discipline (Shulman, 1992).

Shulman (1987) defines curricular knowledge as “the full range of programs designed for the teaching of particular subjects and topics at a given level, the variety of instructional materials available in relation to those program, and the set of characteristics that serve as both the indications and contraindications for the use of particular curriculum or program materials in particular circumstances” (p. 10). Shulman also suggests two subcategories of curricular knowledge, *lateral curriculum knowledge* and *vertical curriculum knowledge* (p. 10). Lateral knowledge indicates the relationship among curriculum in diverse subject areas, while vertical knowledge demonstrates familiarity with the topics and issues within the same subject. Shulman points out that curricular knowledge is the base knowledge for *pedagogical content knowledge*.

Effective teachers acquire in-depth knowledge of how to represent the subject matter to students (Parker & Heywood, 2000). Shulman (1986) named this profound knowledge as *pedagogical content knowledge* (PCK). PCK is teachers’ special form of professional understanding, which provides a special amalgam of content and pedagogy

(Shulman, 1987). However, PCK is not limited to useful representations, unifying ideas, clarifying examples and counter examples, helpful analogies, important relationships, and connections among ideas, although all of these are included (Grouws & Schultz, 1996). PCK should also contain the knowledge of learners and their characteristics, knowledge of educational contexts, knowledge of educational ends, purposes, and values and their philosophical and historical bases (Shulman, 1987), and knowledge of how to transform content into forms that are adaptive to the variations in ability and background presented by the students based on the components of PCK (An, Kulm, & Wu, 2004).

Shulman's categories of teachers' knowledge broaden the perspective on teachers' knowledge. Specially, PCK has huge effect on research on teachers' knowledge of their subject matter and the importance of this knowledge for successful teaching. Critics, however, claim that the categories are sufficient and demonstrate dynamic aspects of teaching mathematics (Meredith, 1995; Stones, 1992), thus they present a simple transmission view of teaching (Meredith, 1993; McNamara, 1991; McEwan & Bull, 1991). In particular, McNamara (1991) questioned whether the content knowledge can and should be distinguished from pedagogical knowledge, as all mathematics subject matter is itself a form of representation. McNamara presented a specified teachers' knowledge category for teaching mathematics.

Fennema and Franke's Research on Teachers' Knowledge for Teaching

Mathematics Based on Shulman's categories of teachers' knowledge, Fennema and Franke (1992) specified components of mathematics teachers' knowledge as presented in Figure 2.2.

- Knowledge of mathematics
 - Content knowledge
 - o The nature of mathematics
 - o The mental organization of teacher knowledge

- Knowledge of mathematical representations
 - Knowledge of students
 - Knowledge of students' cognitions

- Knowledge of teaching and decision making

Figure 2.2. Components of Mathematics Teachers' Knowledge

Knowledge of mathematics indicates conceptual understanding of mathematics including content knowledge. Fennema and Franke (1992) argue that there is a positive correlation between a teacher's conceptual understandings of mathematics and the quality of classroom instruction; therefore, it is important that teachers have knowledge of mathematics.

Fennema and Franke (1992) relabeled PCK calling it knowledge of mathematical representations. Mathematics is seen as a composition of a large set of highly related abstractions; therefore, teachers' knowledge of mathematical representation is significant to students' developing a clear understanding of mathematical concepts (Turnuklu & Yesildere, 2007). Fennema and Franke stated, "if teachers do not know how to translate those abstractions into a form that enables learners to relate the mathematics to what they already know, they will not learn with understanding" (p. 153).

Knowledge of students includes teachers' understanding of their students and the educational context in which students are located (Fennema & Franke, 1992). According to Fennema and Franke (1992), learning is based on what happens in the classroom. Therefore, it is important for teachers to have knowledge of the learning environment and of what students do.

Fennema and Franke (1992) argued that teachers' beliefs, knowledge, judgments, and thoughts might affect the decisions regarding teachers' plans and actions in the classroom. They call this category *knowledge of teaching and decision-making*. The process of decision making in the mathematics classroom may differ based on teachers' teaching experiences. Thus, intensive investigation is needed in order to define the successful ways for making decisions concerning effective mathematics instruction (Robinson, Even, & Tirosh, 1992; Robinson, Even & Tirosh, 1994).

Although Fennema and Franke (1992) built on the work of Shulman and their categories are not significantly different from Shulman's categories, these researchers are more focused on interactive and dynamic aspects of knowledge, which are needed for teaching, suggesting that research methodology needs to concentrate on understanding the interrelations among the theoretical knowledge categories. From this point of view, Ma (1999) asserts that a "profound understanding of fundamental mathematics" requires mathematics teachers to be able to be "instantiated in the connectedness, multiple perspectives, basic fundamental ideas, and longitudinal coherence" (p. 107).

Hill, Ball and Schilling's Research on Teachers' Knowledge for Teaching Mathematics

In spite of Ma's perspective, earlier work by Borko and Putnam (1996) and confirmed later by Ball and Bass (2000), points out that only understanding the fundamental of mathematics is not enough. To become a high-quality elementary mathematics teacher, teachers should know how to teach unique mathematical concepts to special students, how to provide students with a special mathematical knowledge, how

to answer students' mathematical questions, and how to take advantage of curriculum and materials to help students develop their mathematical understanding (Kılıç, 2011).

Ball and Bass (2000) provided a clear scope about knowledge of mathematics education and noted that teaching for understanding requires special mathematical knowledge for teaching. The concept of mathematical knowledge for teaching is discussed at length in Ball and Bass (2000) and Bass (2005) and is classified into four categories: common mathematical knowledge, specialized mathematical knowledge, knowledge of mathematics and students, and knowledge of mathematics and teaching. In a follow-up research study, Hill, Ball, & Schilling (2004) explained the differences among these four categories of mathematical knowledge of teaching. The first item, common mathematical knowledge, specifies mathematical knowledge used to correct students' mathematical statements and the ways of solving mathematics problems. Specialized mathematical knowledge includes building or examining alternative presentations, providing explanations, and evaluating unconventional student methods. The next item shows specialized content knowledge, one that makes it possible to analyze and make sense of a range of methods and approaches to solving computational problems. The last item, knowledge of mathematics and teaching, concerns the knowledge of typical student mistakes or student ability to perform a detailed mathematical analysis to arrive at a correct answer.

In 2008, Ball, Thames, and Phelps presented a specified map of teachers' knowledge for teaching mathematics by rearranging Shulman's initial categories. These categories are presented in Figure 2.3.

- PCK
 - Knowledge of content and students
 - Knowledge of content and teaching
 - Knowledge of content and curriculum
- Subject matter knowledge (SMK)
 - Common content knowledge
 - Horizon content knowledge
 - Specialized content knowledge

Figure 2.3. Key Domains of Teachers' Knowledge for Teaching Mathematics

Ball, et al. (2008) distinguished PCK and SMK first and relocated the other domains of teachers' knowledge. For PCK, Ball et al. take Shulman's (1986) definition of PCK and place three subdomains under PCK: knowledge of content and students, knowledge of content and teaching, and knowledge of content and curriculum. In initial categories of Shulman (1986), the first two domains were independent categories from PCK: knowledge of content and students and knowledge of content and teaching. However, Ball et al. discussed that these two subcategories of teachers' knowledge coincide with the PCK; PCK indicates "the conceptions and preconceptions that students of different age and background bring with them to the learning of those most frequently taught topics and lessons" (Shulman, 1986, p. 7). The third subdomain, horizon content knowledge, indicates that there is an understanding of the relationship among mathematical topics over the span of the mathematics curriculum (Ball, 1993).

SMK is not intertwined with PCK, and teachers need SMK for specific tasks of teaching, such as explaining the purpose of mathematics education to parents and modifying tasks (Ball, et al. 2008). The researchers argued that teachers needed to know the mathematics definition for a given concept and alternative meaning of it as well as be

able to give a solid mathematical explanation. SMK has three subdomains within it: common content knowledge, horizon content knowledge, and specialized content knowledge.

Common content knowledge is “the mathematical knowledge known in common with others who know and use mathematics” (Ball, et al., 2008, p. 403), whereas specialized content knowledge “allows teachers to engage in particular *teaching* tasks, including how to accurately represent mathematical ideas, provide mathematical explanations for common rules and procedures, and examine and understand unusual solution methods to problems” (Hill, Ball, & Schilling, 2008, p. 376). The horizon content knowledge indicates that there is an understanding of the relationship among mathematical topics over the span of the mathematics curriculum (Ball, 1993).

Although Ball et al. (2008) specified teachers’ knowledge domain for teaching mathematics, the definitions of each domain, their locations, and relationships remain controversial. There lacks a clear explanation of each domain (Gearhart, 2007), and the distinction between content knowledge and PCK is vague (Marks, 1990; Eisenhart, Borko, Underhill, Brown, Jones, & Agard, 2012) as is the relationship between SMK and PCK (Even, 1993).

Mishra and Koehler’s New Category of Teachers’ Knowledge for Teaching

In 2006, Mishra and Koehler (2006) described a new category of teachers’ knowledge for teaching: technological pedagogical content knowledge (TPCK), now known as TPACK. TPACK indicates the integration of SMK, PCK, and the knowledge of technology for teaching and learning (Niess, 2005). However, this does not demonstrate that TPACK is merely a straightforward combination of SMK, PCK, and

technology, but rather, it is transformative knowledge combining each constitution into new forms to maximize the effectiveness of educational technology in the classroom (Polly, McGee & Martin, 2010). Teachers also need TPACK when they teach mathematics because it might affect the quality of instruction (Jang & Tsai, 2012). In recent years, TPACK has been accepted in educational research fields; yet, there is not much evidence about how teachers use TPACK effectively in the classroom (Graham, Burgoyne, Cantrell, Smith, Clair, & Harris, 2009; Schmidt, Baran, Thompson, Mishra, Koehler, & Shin, 2009).

Because Shulman (1986) developed categories of teachers' knowledge for teaching, studies have attempted to reveal what knowledge is needed for teaching mathematics and how knowledge is related. The importance of these categories in this discussion is simply that teachers' knowledge consists of basic knowledge and applied knowledge. Teachers should know basic concepts of mathematics and mathematics education (e.g., content knowledge, curriculum knowledge, knowledge of educational context) and how to apply their knowledge in their instruction (e.g., PCK, specialized content knowledge, and TPACK). The studies about teachers' knowledge for teaching mathematics share the basic assumption that categories of basic knowledge and applied knowledge are independent of each other. There is a need for more investigation about this independent relationship because teachers may apply their knowledge on their mathematics instruction as far as they know. This section presented an analysis of the conceptual studies that provides a basis for the empirical studies discussed in following section. The following section presents the review of 20 empirical studies that were selected based on the criteria of this review of literature.

Empirical Studies on Elementary Teachers' Knowledge for Teaching Mathematics

Based on the criteria discussed above, 20 empirical studies were selected for the review. While the number of studies for the review is around 20, it is better to describe each study explicitly and to focus on the features that affect the implications than to draw conclusions by summarizing the studies' results (Wayne & Young, 2003). Therefore, I focused on specific details of each study and found a relationship among them. Based on their relationship, I categorized them into three groups. The criterion of categorizing studies is as follows.

The fundamental criterion for grouping studies is their research questions. The studies' research questions are related to each other to a greater or lesser degree. For example, in their research, Ball, Thames, and Phelps (2008) asked, "What do teachers need to know and be able to do in order to teach effectively?" (p. 340), while Klevé (2010) questioned, "What knowledge is required for the teaching of mathematics?" (p. 157). Although the details are different, both research questions are basically asking how we can define knowledge for teaching mathematics.

Thus, the research questions are categorized into three groups. The three groups are (1) How can we define elementary teachers' knowledge for teaching mathematics? (2) How can we measure elementary teachers' knowledge for teaching mathematics? And (3) What should be related to elementary teachers' knowledge for teaching mathematics? Two groups have subgroups based on the subject of the research design. For instance, while conducting their research, Turner (2010), Polly and Drew (2011), and Izsa'k (2011) focused on representations that are used by teachers in the classroom when the researchers conducted their own research. In this case, those three studies were classified

into one subgroup. For each group, descriptions of all relevant studies and findings, interpretations, and implications are presented. I put forward results at a level of detail to balance content with consistency. That is, the length of the explanation does not indicate any judgments about the strengths and weaknesses of individual studies. More information about each research study is presented in Appendix A.

How can we define elementary teachers' knowledge for teaching mathematics?

Eight studies in this category defined elementary teachers' knowledge for teaching mathematics by analyzing actual classroom instruction. For organizational purposes, this subsection includes three groups based on the main objectives from the research design of studies, focusing on elementary teachers' knowledge for teaching mathematics related to developing the instructional process (e.g., lesson development as well as lesson implementation), presenting mathematical concepts, and understanding students' mathematical background.

Knowledge related to managing instructional process. Only two studies (Stylianides & Ball, 2008; Ball, Thames, & Phelps, 2008) defined elementary teachers' knowledge for teaching mathematics by analyzing teachers' daily tasks for teaching mathematics. Stylianides and Ball (2008) chose two instructional videotapes on proofs from elementary mathematics classrooms from the database of the *Learning Mathematics to Teach* (LMT) project at the University of Michigan from the documented years of 1989 to 1999. The chosen cases were from third grade classrooms in a public school. The researchers also collected field notes from observers, interview transcripts, copies of students' work, and teachers' interviews related to selective teaching episodes. The researchers found elementary teachers need knowledge related to understanding teaching

and learning situations. Stylianides and Ball claimed that the elementary teachers should be able to identify situations in which proof is called for, recognizing the important mathematical differences among these situations. In addition, the two asserted that elementary mathematics teachers should know how to provide appropriate opportunities for their students to engage in the class based on their understanding of the situations.

Ball, Thames, and Phelps (2008) widen the range of instruction within elementary teachers' knowledge for teaching mathematics. The researchers documented and analyzed an entire year of mathematics teaching in a third-grade public school classroom during 1989–1999 from the database of the National Science Foundation. From the analysis, they found that teachers need knowledge for teaching mathematics when they organize methods or decide on procedures before the class begins. In addition, knowledge for teaching mathematics is also required when teachers provide instruction during the lesson and when they evaluate students' work or assignments after the lesson.

Ball, Thames, and Phelps (2008) concluded that two kinds of elementary teachers' knowledge for teaching mathematics are needed throughout the lesson. One is referred to as *Common Content Knowledge* (p. 399), which represents knowledge related to mathematics content itself. The other area, *Specialized Content Knowledge* (p. 400), is related to the process of teaching, which includes making mathematical sense of students' work and choosing powerful ways of representing it. The researchers highlighted the importance of these two kinds of elementary teachers' knowledge for teaching mathematics. The former is needed as fundamental conditions for accurate mathematical description and detection of students' mathematical errors. The latter is also important because it could make mathematics understandable for students.

Knowledge related to presenting mathematical concepts. Three studies (Turner, 2008; Izsa'k, 2006; Polly, 2011) defined elementary teachers' knowledge for teaching mathematics by focusing on teachers' ways of presenting mathematics concepts.

Turner (2008) used the Knowledge Quartet (KQ) developed by Rowland, Huckstep, and Thwaites (2005), as a framework. The four dimensions of the KQ are *Foundation* (understanding of mathematics content), *Transformation* (demonstrating knowledge for teaching mathematics in planning or teaching mathematics in the classroom), *Connection* (connecting discrete concepts of mathematics), and *Contingency* (dealing with unexpected situations during the class) [p. 68]. Of these, Rowland, Huckstep, and Thwaites (2005) focused on *Transformation* in this study. The researcher surveyed 12 beginning teachers' mathematics classrooms from their initial year to their third year of teaching with a focus on the teaching of algorithms. From the observation, the researcher discovered that differences did exist among teachers' knowledge for teaching mathematics for selecting representations. Elementary teachers who seemed to have a lack of knowledge were apt to choose representations that appealed to their eyes rather than that contributed in helping students understand mathematical concepts. Therefore, the researcher concluded that elementary teachers' knowledge for teaching mathematics might be expressed in the choice of representations for their mathematics classes.

Similarly, Izsa'k (2006) emphasized elementary teachers' knowledge for teaching mathematics related to how teachers present mathematical concepts. In this study, the researcher used a framework that was informed by a *perspective on knowledge* (p. 98), which emphasized diverse and refined knowledge elements. Applying this framework, the researcher surveyed two sixth-grade elementary teachers' instructional procedurals.

During the observation, Izsa'k focused on the ability of designing mathematics instruction by using proper drawings. Also, Izsa'k concentrated on the analysis of using drawings that represent fractions concepts. That is, Izsa'k suggested that teachers needed to assemble structures related to carrying out instruction with flexibility that are supported by drawn versions of the distributive property. Another important conclusion that Izsa'k made is that this kind of elementary teachers' knowledge for teaching mathematics is not adequate for understanding and appraising the diverse ways students present evidence of their learning of multilevel structures.

Taking an approach that is somewhat different from both Turner (2008) and Izsa'k (2006), Polly (2011) studied how teachers present mathematical concepts using technology. To conduct this research, Polly selected two teachers based on their self-reports about their use of technology in mathematics class. The two teachers participated in a professional development program to learn how to use technology in a mathematics classroom that consisted of over 30 hours of workshops for a period of 5 days. After completing the program, Polly observed the two teachers' mathematics classes. From the observation, the researcher found that these teachers used technology only in ways that presented basic knowledge and did not facilitate higher thinking skills despite the teachers' preparation to do so as a result of the workshops. Consequently, the researcher suggested that teachers need special knowledge, which was referred to as *Technological Pedagogical and Content Knowledge* (TPACK) (p. 95). TPACK consists of two kinds of knowledge. The first is related to presenting mathematics concepts by using technology, and the second is connected to providing mathematics content, which makes students think through technology. The implication put forward is that if elementary teachers have

these two types of knowledge, they would use technology in effective ways to develop students' thinking and problem-solving skills. Not unlike Turner and Izsa'k, Polly's conclusions, although relevant to the effective use of technology, point to the value of teacher development and preparation of their knowledge for teaching mathematics. Furthermore, in each of these studies, it is clear that teachers' knowledge for teaching mathematics does influence student learning and achievement.

Knowledge related with understanding about students' mathematical background. Three studies (Empson & Junk, 2004; Anderson & Kim, 2003; Kleve, 2010) described elementary teachers' knowledge for teaching related to students' mathematical background.

Empson and Junk (2004) built their own framework for elementary teachers' knowledge for teaching mathematics from a review of the literature. The researchers posited that elementary teachers' knowledge for teaching mathematics should consist of a broad and deep understanding of children's thinking about mathematics. The researchers interviewed 13 elementary teachers in the third, fourth and fifth grade from the same school located in an urban district in Texas. All the teachers were interviewed once with five open-ended questions (e. g., suppose that you were teaching multidigit multiplication. What are at least three different strategies that children might use to solve 18×25 ?) With the data from these interviews, the researchers developed three kinds of scenarios about how teachers made sense of students' nonstandard strategies for mathematics operations. These scenarios support the belief that elementary teachers should have broad and deep knowledge of students' nonstandard strategies as well as have a way to deal with them. In addition, the researchers concluded that teachers who have a deep

comprehension of the children's way of understanding mathematics might teach mathematics better than those who do not.

Anderson and Kim (2003) defined elementary teachers' knowledge for teaching mathematics as the ability to analyze students' background knowledge and belief of mathematics from the literature review. The researchers found that a teacher who organized instruction and prepared mathematics manipulatives based on her students' previous knowledge of mathematics conducted instruction successfully. On the other hand, the other teacher who was unprepared and had a lack of knowledge about students' previous mathematical understanding could not help students grasp mathematics concepts properly during the class. The researchers argued that these examples support their belief that teachers should have knowledge for teaching mathematics about analyzing students' background knowledge and beliefs about a mathematical topic. They concluded that elementary teachers' knowledge for teaching mathematics must indeed be related to students' learning.

Kleve (2010) used the Knowledge Quartet (KQ) as an analytical framework to investigate how a teacher's knowledge for teaching mathematics appeared in the lesson. Based on the framework, Kleve videotaped and analyzed a lesson about fractions taught by a fifth-grade classroom teacher in Norway. In addition, the researcher interviewed the teacher after the conclusion of the classroom instruction. The researcher focused on how the teacher responded to students' unexpected questions during the lesson and found that the teacher reacted to each student's question in different ways based on the student's learning style. By showing the teacher's different explanations about the same topic, Kleve revealed that elementary teachers' knowledge for teaching mathematics related to

teaching mathematics in various ways based on the needs of the learner with whom the teacher was working.

A common perspective of the studies reviewed in this section suggests that elementary teachers' knowledge for teaching mathematics does not simply mean that they understand mathematical concepts. In addition, the studies focused on elementary teachers' knowledge for teaching mathematics related to diverse aspects of instruction regarding planning and conducting mathematics lessons, using mathematical representations, and students' mathematical understanding. The sum of these studies emphasize that teachers should know how to express their knowledge for teaching mathematics based on students' levels of mathematical understanding and backgrounds.

It is reasonable to assume that the findings from these empirical studies contribute to our understanding of the importance of elementary teachers' knowledge for teaching mathematics. However, if these findings represent all aspects of elementary teachers' knowledge for teaching mathematics, a question remains to be answered. As Fenstermacher and Richardson (2005) pointed out, instruction can be diversified because of resources, students, and surroundings. However, the studies in this category are limited, as all aspects of mathematics instruction related to teachers' mathematical knowledge were not addressed. For example, showing proper examples, illustrations, or manipulatives could be important for teaching mathematics, yet it is not the only way. Also, all of the studies focused on only one mathematics content area: number and algorithms. Diverse studies about the other areas show that there could be other types of elementary schoolteachers' knowledge for teaching mathematics related to using materials. For instance, Polya (1985) highlighted the importance of mathematics teachers'

questions when they teach problem solving to students. On the other hand, Clements (1998) emphasized elementary students' sensorial experience to form spatial sense.

In addition, the research in this category did not provide specific guidelines for students. However, various studies about characteristics of elementary mathematics students illustrate that it is hard to provide a single definition of elementary mathematics students (e.g., Maloney, Risko, Ansari, & Fugelsang, 2010; Gadanidis, Hughes & Cordy, 2011; Thornton, 1997). Although a teacher may use appropriate mathematics representations, it would be meaningless if students cannot understand them. In this case, another elementary teachers' knowledge for teaching mathematics might be needed, which is different from how knowledge is defined above, such as understanding students' previous mathematics knowledge.

How can we measure elementary teachers' knowledge for teaching mathematics? There are three studies that focus on measuring elementary teachers' knowledge for teaching mathematics (Hill, Schilling, & Ball, 2004; Dalaney, Ball, Hill, Schilling, & Zopf, 2008; Cai, 2005). Hill, Schilling, and Ball (2004) focused on developing an instrument for measuring elementary teachers' knowledge for teaching mathematics. The development steps that the researchers employed are as follows.

First, Hill, Schilling, and Ball (2004) identified knowledge for teaching mathematics that is required for teaching by analyzing mathematics curriculum materials, examples of students' work, and observations on teachers' personal experience. From the survey, the researchers defined elementary teachers' knowledge for teaching mathematics with two kinds of subknowledge. One is referred to as *common knowledge of content* (p. 12), representing knowledge related to mathematics content itself. The other part,

knowledge of students and contents (p. 14), is related to the ways to teach mathematics to students.

Second, based on their classification of knowledge, Hill, Schilling, and Ball (2004) developed 138 questions, including multiple-choice items for elementary mathematics teachers over two mathematical content areas, number concepts, and operations. With these questions, the researchers completed three kinds of test paper forms and piloted them with elementary teachers who participated in the teacher education programs of California's Mathematics Professional Development Institutes. From the pilot test, the researchers obtained responses to each of three pilot forms: 640 cases for Form A, 535 cases for Form B, and 377 cases for Form C.

Third, Hill, Schilling, and Ball (2004) conducted a statistical analysis of the data obtained from the pilot test. The researchers used BILOG, a program that converts data properly to the response theory analyses program developed by Mislevy and Bock (1997). In addition, Hill, Schilling, and Ball examined data by using three types of analysis: *exploratory factor analyses* (explanation about three subcategories of the factors), *factor analyses* (factors related to knowledge of content), and *bi-factor analyses* (factors related to knowledge of student and content) [p. 19]. Based on the criteria of the analysis, they calculated validity and correlation for each question statistically. From the analysis, Hill, Schilling, and Ball (2004) concluded that elementary teachers' knowledge for teaching mathematics is measurable through paper-based tests. Also, the researchers found that two kinds of elementary teachers' knowledge for teaching mathematics, *common knowledge of content* (p. 12) and *knowledge of students and contents* (p. 14) could be distinguished. Based on these findings, this study suggested that elementary teachers'

knowledge for teaching mathematics related to teaching could be measured if every factor of the elementary teachers' knowledge for teaching mathematics is identified.

On the other hand, Dalaney, Ball, Hill, Schiling, and Zopf (2008) examined four Irish elementary teachers' knowledge for teaching mathematics with a translated measurement instrument, including multiple-choice items, which were provided by LMT Project. With the translated paper-based tests, the researchers interviewed the teachers to confirm the correspondence between the result from the paper-based test and what teachers actually know. The researchers found some intersection between Irish and American elementary teachers' knowledge for teaching mathematics. However the translated measurement instrument was not constantly applicable to measure Irish elementary teachers' knowledge for teaching mathematics. The researchers found the reason for this inconsistency might be cultural differences inherent in mathematics education (e.g., differences in mathematical language, differences in measurement units, and differences in the use of representations of mathematical concepts). As a result, they suggested that there is potential to develop international instruments for measuring elementary teachers' knowledge for teaching mathematics. However, the researchers also pointed out that more studies are needed to reduce differences about the way mathematics is taught.

Cai (2005) measured and compared elementary teachers' knowledge for teaching mathematics between the United States and China in a different way. In this research, Cai chose 11 U.S teachers and 9 Chinese teachers who were recommended by a group of U.S. or Chinese mathematics educators. To compare elementary teachers' knowledge for teaching mathematics, the researcher analyzed 11 U.S. and 9 Chinese teachers' lesson

plans and interviewed all teachers based on the use of representations to convey mathematics concepts. The analyzing criteria employed in this research are as follows: (1) *generating pedagogical representations for classroom instruction*, (2) *knowing students' representations and strategies in problem solving*, and (3) *evaluating students' representations and solution strategies* (p. 142). From the analysis, the researchers discovered that Chinese teachers used representations to explain the process of algorithm than concepts, and U.S. teachers did the reverse. Cai found causes in differences regarding cultural values of mathematics instruction. That is, teachers' beliefs about what is important in mathematics teaching might be affected by cultural values, and this might explain the differences between elementary teachers' knowledge for teaching mathematics in the two countries.

In the previous section, findings showed that even teachers who have high levels of knowledge for teaching mathematics of content might not teach well if they do not know how to teach mathematics. Likewise, it is difficult to say that to know the ways of teaching guarantee teaching well. Consider teachers who provide instruction perfectly based on what they know regardless of students' attention or interests. Can we say that these teachers have high knowledge for teaching mathematics related to teaching? Even worse, can an elementary mathematics teacher who learned teaching methods by rote teach mathematics well? Of course, teachers who have more knowledge for teaching mathematics related to teaching have a higher chance of teaching better than do those who have no knowledge for teaching mathematics. However, as elementary teachers' knowledge for teaching mathematics was defined in actual mathematics classrooms,

elementary teachers' knowledge for teaching mathematics also should be measured in the actual classroom.

In addition, there is no general agreement on what elementary mathematics teachers should know. As presented above, empirical studies that attempted to define elementary teachers' knowledge for teaching mathematics concentrated on only one mathematics content area. Similarly, the study in this section that developed an instrument to measure elementary teachers' knowledge for teaching mathematics only contained items that focused on the area of numbers and algorithms. Whether this measurement could be applied to the other mathematics areas remains a question.

There are two studies that attempt to measure teachers' knowledge for teaching mathematics by using measurement instruments that were developed in the United States. Ng (2011) used tests developed by LMT Project in the United States. without any difficulty, while Dalaney et al. (2011) pointed out differences in teaching mathematics between the two countries. In line with Dalaney et al.'s opinion, Cai (2005) also found that there are differences between what is considered valuable in mathematics education based on the country's culture.

The attempt to measure international elementary teachers' knowledge for teaching mathematics and to compare the results to U.S. elementary teachers' knowledge for teaching mathematics might be meaningful for international comparison of teacher quality. However, the question that remains is how to develop measurement instruments that overcome cultural differences. As Hill (2008) pointed out, elementary teacher knowledge for teaching mathematics is related to teachers' beliefs about mathematics. If

the measurement instruments used ask about mathematics instruction contain a value judgment about mathematics education, it will be difficult to remain relevant.

What is related to elementary teachers' knowledge for teaching mathematics? In the past, the assumption was that it was hard to define the impact of each elementary mathematics teacher's ability because a teacher's effectiveness was overshadowed by classroom variables like previous level of students' achievement (River & Sanders, 2005). However, recent studies have attempted to reveal the influence of teachers' knowledge for teaching mathematics on how they teach mathematics. Also, some studies have examined which aspects of elementary schools correlate with elementary teachers' knowledge for teaching mathematics. In this section, seven empirical studies (Hill, Rowan & Ball, 2005; Tanase, 2011; Hill, 2008; Hill, 2010; Magolinas, Coulange, & Bessot, 2005; Bell, Wilson, Higgins, & McCoach, 2010) endeavored to uncover what is connected to elementary teachers' knowledge for teaching mathematics. For structural purposes, this section includes two subgroups focusing on what is affected by elementary teachers' knowledge for teaching mathematics and what affect there will be on elementary teachers' knowledge for teaching mathematics.

What is affected by elementary teachers' knowledge for teaching mathematics? Four studies (Hill, Rowan, & Ball, 2005; Tanase, 2011; Hill, 2008) focused on the effect of elementary teachers' knowledge for teaching mathematics.

Hill, Rowan, and Ball (2005) investigated whether and how elementary teachers' knowledge for teaching mathematics contributed to improving student mathematics achievement. The data from first- and third-grade students and their teachers in 115 elementary schools were gathered during the 2000–2001 through the 2003–2004

academic years. The researchers collected data on students' and parents' interviews that involved students' rate of absence from mathematics classes as well as data on teachers through the teacher self-reported instruments and questionnaires that included their educational background (e.g., teacher experience and certification) and professional development experience. The researchers computed student achievement scores with *CBT/McGraw-Hill's Terra Nova* (p. 382) via item response theory scoring procedure and coded teachers' information (e.g., certification was coded 0 or 1 depending on its presence). After organizing the data, the researchers calculated the correlation between student achievement and teachers' knowledge for teaching mathematics statistically. They found that in general, elementary teachers' knowledge for teaching mathematics for teaching had a positive effect on student mathematics achievement. In addition, findings suggested that teachers' knowledge for teaching mathematics had little effect on minority students' academic achievement.

Tanase (2011) also focused on elementary student mathematics achievement in relation to elementary teachers' knowledge for teaching mathematics. In this research, Tanase observed four Romanian first-grade teachers' lessons about place value concepts. The researcher used different methods to measure elementary teachers' knowledge for teaching mathematics and student achievement. Tanase interviewed all teachers to evaluate their knowledge for teaching mathematics and gave students paper-and-pencil tests at the end of the semester. At the same time, the teachers developed their own tests for students. That is, students took a different test based on what they had learned. After comparing the results from measuring both teachers' knowledge and student achievement, the researcher found that there is positive correlation between teachers' knowledge for

teaching mathematics and student achievement. Although teachers who had high knowledge for teaching mathematics provided more difficult tests to students than did those who had relatively low knowledge for teaching mathematics, most of their students got high scores. However, the researcher found that there was an exception; teachers' knowledge for teaching mathematics had affected most students except students who had earned low marks on their pre-tests. Students who had already received low scores on the previous achievement tests still performed at or below-average levels on their final tests regardless of teachers' knowledge for teaching mathematics.

On the other hand, Hill (2008) concentrated on the quality of mathematics instruction related to elementary teachers' knowledge for teaching mathematics. In order to find the relation, the researcher chose 10 teachers who taught various grades from second to sixth. The researcher measured these teachers' knowledge for teaching mathematics with paper-based tests, which were developed by the researcher's previous project in 2002. In addition, Hill collected data by interviewing these teachers and videotaping their mathematics instruction. Then, the researcher evaluated the quality of their mathematics instruction by using self-developed rubrics. After that, the researcher calculated the correlation between scores of teachers' knowledge for teaching mathematics and scores of the quality of instruction statistically. Results indicated that there is a positive correlation between elementary teacher's knowledge for teaching mathematics and the quality of instruction given.

However, Hill (2008) suggested that elementary teachers' knowledge for teaching mathematics does not affect the quality of mathematics instruction directly. From the observation of teaching, the results of the research suggest that there are mediating

factors between teachers' knowledge for teaching mathematics and instruction, such as *the use of curriculum materials, beliefs about mathematics, and the effects of teacher professional development* (p. 499). Based on these findings, Hill concluded that the most fundamental element of determining the quality of mathematics instruction is teachers' knowledge for teaching mathematics.

Only one study (Hill & Lubienski, 2007) concentrated on the aspects of elementary school related to elementary teachers' knowledge for teaching mathematics. This research applied *Hierarchical Linear Models* (HLM) [p. 758] to analyze results from an instrument administered to 533 teachers who had attended the California Mathematics Professional Development Institutes in the summer of 2002. To measure teachers' knowledge for teaching mathematics, the instrument consisted of common tasks of mathematics instruction for the mathematics content area of numbers and operations. The researchers calculated the teachers' scores with the instrument and compared them with the population of students of the school where the teachers worked. Results from the study indicated that there was a relationship between teachers' knowledge for teaching mathematics and their schools' student populations. For example, schools enrolling larger numbers of students who had low marks on their achievement test, including Hispanic students, tended to employ teachers who had slightly less knowledge for teaching mathematics than did their counterparts on average. Although patterns emerged, the researchers warned that some caution must be taken regarding the generalizability of the findings, especially as a nonrandom sample of teachers participated in the study.

What affects elementary teachers' knowledge for teaching mathematics? Five studies examined what affects elementary teachers' knowledge for teaching mathematics.

Using a sample of teachers ($n = 625$) from a national database, Hill (2010) investigated the relationship between elementary teachers' knowledge for teaching mathematics and the teachers' educational backgrounds. To evaluate elementary teachers' knowledge for teaching mathematics, Hill developed an instrument referred to as *mathematical knowledge for teaching measures* (MKT measures) [p. 545] based on the researcher's previous study. The instrument would measure items in the content area of numbers and operations based on categories described in Ball, Thames, and Phelps's research (2008). In addition, Hill developed a series of questions in order to estimate teachers' experiences (e.g., years of experience, professional development experience). Hill combined teachers' MKT scores and their experience and calculated the correlation between them statistically. Consequently, Hill saw that the analysis did not illustrate a significant relationship between MKT and mathematics-related professional development experiences. However, Hill did find that teachers' experiences are closely related to MKT. An implication of the research is that extensive professional development participation might not be an indicator of elementary teachers' knowledge for teaching mathematics.

A study preceding Hill's (2010) research was conducted by Margolinas, Coulange, and Bessot (2005). These researchers only focused on the effect of teacher experience on elementary teachers' knowledge for teaching mathematics; yet, they reached a similar conclusion as Hill had (2008). The researchers selected two previous studies and used their data to examine how teachers obtain knowledge for teaching mathematics that emerges from teachers' activity and observation on students' ways of solving problems during the classroom interaction. The data included audio or video recording, copies of students' work, and teachers' written preparation and interviews with the teacher before

or after the lesson. From the analysis of the data, the researchers found that teachers kept modifying and developing their knowledge for teaching mathematics while they were observing their own students' replies and activities during the class. In addition, the researchers found teachers improved their knowledge for teaching mathematics related to students' ways of dealing with mathematical problems based on their teaching experience. The researchers concluded that this type of elementary teachers' knowledge for teaching mathematics might play a fundamental role in improving their other knowledge, such as understanding students' ways of dealing with mathematics problems.

Bell, Wilson, Higgins, and McCoach (2010) examined the increasing amounts of elementary teachers' knowledge for teaching mathematics gained through teacher education programs. However, this study arrived at a different conclusion than Hill's (2008) research did. This study investigated 111 elementary teachers participating in the nationally disseminated professional development programs from 10 different areas in the United States. Bell and Wilson used two kinds of procedures to measure teachers' knowledge for teaching mathematics: One is a self-developed open-ended question, and the other is multiple-choice measurement that was provided by the Study of Instructional Improvement. Comparing test results from pretest and posttest, results revealed that elementary teachers' knowledge for teaching mathematics improved through teacher education programs.

Li and Huang (2008) investigated the differences among elementary teachers' knowledge for teaching mathematics according to teaching experiences. In this study, 18 Chinese teachers participated from two different elementary schools located in a southeast city in Mainland China. They had various teaching experiences ranging from 4

to 30 years. The investigation used a paper-and-pencil test to detect if these teachers' knowledge for teaching mathematics related to their understanding of mathematics representations in the classroom. Li and Hung selected questions from textbooks and items from TIMSS 2003 background questionnaires (TIMSS, 2003). The teachers had to solve mathematics questions or write how they would explain the solution to students. The researcher identified teachers' explanations and categorized them into three groups: *constructing counter examples with specific numbers*, *constructing counter examples with diagrams*, and *constructing a counter proof with the correct use of algorithms symbolically* (p. 851). Based on the process of categorization, the researchers calculated elementary knowledge for teaching mathematics related to both mathematics content and teaching mathematics. After comparing these results with the teachers' experience, the researcher concluded that the more experienced elementary teachers had higher scores in knowledge for teaching mathematics than the less experienced teachers.

Ng (2011) also found that there were significant differences among groups of teachers based on experience in teaching. The researcher compared 184 Indonesia elementary teachers' records on teaching experience, including grade level, with their knowledge for teaching mathematics. The researcher used a paper-based measurement instrument, which was developed by LMT Project in America. The researcher also found that teachers who had taught diverse grades received higher scores on their tests.

A common viewpoint of the studies reviewed in this section is that elementary teachers' knowledge for teaching mathematics is related to diverse aspects of elementary education. In particular, elementary teachers' knowledge for teaching mathematics is

connected to student achievement, including teacher certification and teacher education programs, teacher experience, and student demographics of an elementary school.

Regarding student mathematics achievement, three studies (Hill, Rowan, & Ball, 2005; Tanase, 2011; Hill, 2008) suggested that elementary teachers' knowledge for teaching mathematics have an effect on student achievement. However, there are limitations regarding the effect of elementary teachers' knowledge for teaching mathematics. While elementary teachers' knowledge for teaching mathematics did affect most student mathematics achievement, there was little affect of elementary teachers' knowledge for teaching mathematics on minority students and students who had received low marks on previous achievement tests.

Although this review considered only three studies, which focused on the affect of elementary teachers' knowledge for teaching mathematics, the findings from these studies demonstrated different views. Concerning the effect of teacher experience, two studies (Hill, 2010; Magolinas, Coulange, & Bessot, 2005) reached the same conclusion: There is a positive correlation between teacher experience and elementary teachers' knowledge for teaching mathematics. However, the conclusions from two of these studies (Hill, 2010; Higgins & McCoach, 2010) differed from each other regarding whether and to what degree teacher education programs improve elementary teachers' knowledge for teaching mathematics.

Only Hill and Lubienski's (2007) study concentrated on the relationship between elementary teachers' knowledge for teaching mathematics and student demographics. Their research found that teachers in schools with higher proportions of students who are

Hispanic and had received low mathematics achievement scores had a lack of knowledge for teaching mathematics.

The findings in this section generate some controversy. Hill's (2008) results, suggesting that there was little affect from teacher education programs or from the existence of certification on teachers' knowledge for teaching mathematics, threaten the reason for maintaining teacher education programs or teacher certification systems. Of course, there is a different opinion about the affect of teacher education programs. However, the most important thing is whether the affect of teacher education programs or of teacher certification is not reliable. A question that needs to be answered then is how do elementary schools employ highly qualified teachers with strong knowledge for teaching mathematics?

Yet, the other studies revealed that teaching experience does affect teachers' knowledge for teaching mathematics, and this leads to a question about how beginning elementary mathematics teachers may improve their knowledge for teaching mathematics. Furthermore, based on results from the other studies in this section, it seems elementary teachers' knowledge for teaching mathematics affects student achievement. Subsequently, students who learn mathematics from a teacher who is inexperienced might receive lower scores regardless of their ability than will students who learned from more experienced teachers. This issue should be discussed because the way to handle this issue might be important in terms of school equality.

The other question regarding the findings in this section is about the distribution of teachers. If elementary teachers' knowledge for teaching mathematics is not helpful in improving minority student mathematics achievement or for students who had low marks

on their pretests, what problems do those students learning from teachers with poor knowledge for teaching mathematics face? This issue also leads to doubts about teachers' knowledge for teaching mathematics. If elementary teachers' knowledge for teaching mathematics is only applied to students who already have middle or high mathematics achievement or do not belong to a minority group, there is unquestionably a missing part on elementary teachers' knowledge for teaching mathematics.

Interpretive Summary and Critical Analysis

Since the establishment of common schools in the 1830s, the importance of the quality of elementary teachers has been considered vital for students' successful learning in a school. Specifically, recent research revealed that teachers are a significant indicator of student mathematics achievement (River & Sanders, 2002). Studies also demonstrated that teachers' knowledge for teaching mathematics affects the quality of instruction (e.g., Stylianides & Ball, 2008; Ball, Thames, & Phelps, 2008) as well as students' mathematics learning outcomes (e.g., Hill, Rowan, & Ball, 2005; Tanase, 2011).

In particular, Vygotsky (1978) pointed out that elementary teachers should know students' mathematical background, which includes conceptual and procedural mathematical understanding as well as content knowledge in order to build new knowledge for teaching mathematics effectively. based on students' prior knowledge. In this case, elementary teachers' knowledge for teaching mathematics may affect the teachers' use of language; elementary teachers' use of verbal or non-verbal language may play a pivotal role in students' creative and critical thinking in mathematics learning.

Apart from Vygotsky, diverse studies attempt to define categories of elementary teachers' knowledge for teaching mathematics and their impacts on mathematics

instruction. Regarding the categories of elementary teachers' knowledge for teaching mathematics, there is a sharp viewpoint toward it among diverse studies; elementary teachers need to know the content of mathematics and the ways of transforming mathematical concepts pedagogically based on students' mathematics background.

However, it is highly likely that elementary teachers' knowledge for teaching mathematics is misleading in terms of student mathematics achievement. Results of studies reviewed here demonstrate that elementary teachers' knowledge for teaching mathematics fit the necessary conditions for improving student achievement in mathematics, but do not provide the sufficient conditions for it. For example, the finding from Hill's (2004) research shows that elementary teachers' knowledge for teaching mathematics has little effect on students with low marks. Also, the explanation about the effectiveness of elementary teachers' knowledge for teaching mathematics is not sufficient.

In addition, there are not many empirical studies in this field. There are few scholars conducting research in the area of elementary teachers' knowledge for teaching mathematics. When completing the literature review, the researcher found that searches for the same scholars, but of different studies, seemed to emerge again and again. Therefore, not only does more research in this area need to be done, but more important, there needs to be an increase in the number and type of scholars doing this work. Expanding the field of researchers would provide new ways of examining elementary teachers' knowledge and at the same time, it may provide critical information about effects and factors of knowledge for teaching mathematics for teaching.

Because elementary mathematics education was defined as one of scholarship, countless mathematics educators have produced various theories and methods to improve elementary students' mathematical understanding. However, opinions still differ on how to provide effective mathematics teaching.. The reason is that the subjects of mathematics education are human beings who are infinitely complex. Likewise, elementary teachers' knowledge for teaching mathematics is very difficult to define. Therefore, diverse approaches toward elementary teachers' knowledge for teaching mathematics and its effectiveness are needed in order to improve elementary teachers' knowledge for teaching mathematics, and consequently, to support students effectively learning mathematics in a classroom.

To address various gaps in the literature, this study examines South Korean elementary teachers' knowledge for teaching mathematics. It used a qualitative research approach to understand elementary teachers' knowledge for teaching mathematics and its influence on teacher instruction. Diverse types of in-depth data were collected to provide a detailed account of South Korean elementary teachers' knowledge for teaching mathematics. A qualitative research approach including diverse artifacts (e.g., interviews, observation) offered a comprehensive picture of South Korean teachers' use of their knowledge during instruction periods. The next chapter explains the methodology that guided the data collection and analysis procedures for this study.

CHAPTER 3

Methodology

One of the conditions for a well-established research study is that the research design and methodology correspond with the research question (National Research Council, 2002). The primary research question and subquestions for this study are as follows.

What kinds of knowledge for teaching mathematics do South Korean elementary schoolteachers use in their mathematics instruction?

1. How does each category of the South Korean elementary teachers' knowledge for teaching mathematics influence the teachers' mathematics instruction?
2. How is each category of the South Korean elementary teachers' knowledge for teaching mathematics structured?
3. How does each category of the South Korean elementary teachers' knowledge for teaching mathematics relate to one another?

To answer these questions, a qualitative approach is appropriate because this type of question requires a descriptive response. "In a qualitative study, the research question often starts with *a how* or *a what* that initial forays into the topic describe what is going on" (Cresswell, 1998, p. 17).

For the purpose of uncovering hidden aspects of elementary teachers' knowledge for teaching mathematics and the teachers' practical use of it, this study focuses on South Korean elementary schoolteachers. Therefore, an additional assumption of this study is that mathematics teaching is context specific. That is, this study's finding should be understood in the context of the educational setting in South Korea, which will be

discussed in Chapter 4. This recognition of the importance of context prompts the need for a qualitative approach to the research because interpretive methods are most appropriate when one needs to know more about the characteristics from specific surroundings (Erickson, 1986).

A discussion of the rationale for the qualitative approach is integrated throughout various sections in this chapter. This chapter also includes the following sections: research design, participants and context, settings, data sources, procedures, and data analysis, and limitations of the methods.

Research Design

Multiple Case Studies Approach

Among diverse qualitative research methods, this study used a multiple case study approach to answer the research question. Based on this framework, this study assumed that teachers' use of language is critical to understanding their knowledge for teaching mathematics, which affects mathematics instruction. Thus, intensive observations regarding the South Korean elementary teachers' use of language in their mathematics instruction are needed in order to answer the research question based on the framework. In addition, this study demonstrated from the review of literature that diverse components (e.g., teaching experiences, beliefs) affect teachers' knowledge for teaching mathematics. Therefore, rigorous interviews were also needed to understand the teachers' background, which affects their knowledge, to conduct an in-depth analysis of obtained data.

Thus, the most appropriate research approach is case study. The case study seeks to understand the larger phenomenon through detailed examination of a specific case and therefore focuses on a particular instance (Rossman & Rallis, 2003). Case study research

also provides detailed explorations of single examples that is “an instance drawn from a class” of similar phenomena (Adelman, Jenkins, & Kemmis, 1983. p. 3).

However, case studies are context dependent because they focus on the characteristics of the specific case (Rossman & Rallis, 2003). Thus, conclusions from the case may not be applied directly to another case. To overcome this restriction, this study applied a multiple case study approach with 11 cases of South Korean elementary teachers. Multiple case study analysis is a research method that enables the comparison of similarities and differences in the incidents, events, and progressions that are the units of analysis in case studies (Ayres, Kavanaugh, & Knafl, 2003). Conducting multiple case study analysis may allow us to reveal new aspects of the phenomena and to produce general models (Strentton, 1969). Multiple case study analysis also improves researchers’ strategies to refine developing concepts and build new theory (Ragin, 1997; Eckstein, 2002).

However, multiple case study approach is generally considered an overall strategy rather than a type of research (Stake, 2000). Therefore, this study will apply sociolinguistic tradition and grounded theory to develop specific strategies for describing and analyzing the data generated from the study. Detailed explanations of sociolinguistic tradition and grounded theory are presented in the following section.

Sociolinguistic Tradition and Grounded Theory

From Chapter 1, an assumption highlighted and grounded in Vygotskian theory is that elementary teachers’ use of language is critical to understanding and defining their knowledge for teaching mathematics. In this case, languages contain both verbal and nonverbal expressions. In order to understand the meaning of South Korean teachers’ use

of language in their teaching, this study will draw on the sociolinguistic tradition. Sociolinguistic tradition looks for the meaning in words, gestures, and signs (Rossman & Rallis, 2003). In particular, sociocommunication studies that focus on languages and communication suggest that a person's identity is intrinsically related to the way of using languages (Wolcott, 1994). Sociolinguistic tradition requires the in-depth analysis of naturally occurring speech events and interactions within their context (Erickson, 1986). In this case, naturally occurring speech indicates those events and interactions that have not been created by the researcher, and these researchers often video- or audiotape events and analyze the transcription. Therefore, this study will videotape the participants teaching in their natural settings and attempt to find the meaning of the participants' language in the context of the lesson.

Although the study is influenced by sociolinguistic tradition, it is hard to say that this study applies sociolinguistic approach completely. Pure sociolinguistic tradition avoids unnatural speech events such as interviews (Rossman & Rallis, 2003). However, this study will conduct three interviews with each participant in order to understand their knowledge for teaching mathematics. While sociolinguistics seeks how social characteristics (e.g., age, gender, and socioeconomic status) shape language (Gall, Borg, & Gall, 1996), this study will focus on how elementary teachers' knowledge influences their use of language in their teaching. Therefore, there is a need for an in-depth investigation of what kind of knowledge for teaching mathematics South Korean elementary teachers have, which may not be present in social characteristics. For this reason, interviews will be conducted in order to understand teachers' knowledge for teaching mathematics and to reveal the connection between their knowledge and their use

of language. In addition, to reveal the hidden aspects of teachers' language, which may not have emerged from the interviews, this study applied member check strategies that allowed participants to confirm the researchers' interpretations on the transcripts. The detailed process of member check will be discussed in the following section.

As noted above, this study will apply a multiple case study approach with diverse participants. For a multiple case study approach, grounded theory may provide an analytic approach to qualitative inquiries because it is useful when multiple realities exist (Charmaz, 2002). In addition, the purpose of this study is to uncover and to theorize on South Korean elementary teachers' knowledge for teaching mathematics in their teaching context and the relationship among them. Rossman and Rallis (2003) asserted that "the researcher enters the study with few preconceived ideas about what matters to participants in the setting, and analysis and search for theoretical understanding of the phenomena begin very early in the process and continue throughout" (p. 106) with the tradition of grounded theory. With this perspective, Strauss and Corbin (1994) also noted that "theory evolves during actual research, and it does this through continuous interplay between analysis and data collection" (p. 273). This inductive approach of building new theory is compatible with the purpose of the present study. Therefore, I applied grounded theory to construct robust explanations of South Korean elementary teachers' use of their knowledge for teaching in their teaching practices.

Grounded theory offers systematic methods for analyzing data and ways to theorize on findings emerging from the data (Glaser & Strauss, 1967). In particular, grounded theory is distinguished from other theories or approaches because of its ongoing process of analysis (Charmaz, 2002). Based on the methodology of grounded

theory, preliminary analysis will encompass coding of data, and descriptions will be added to organize the data more coherently. The initial codes will be organized into several themes. These codes and themes are continually revised with new insights that emerge from the process of data analysis. Through this process, a unifying theory or a model regarding South Korean elementary teachers' knowledge for teaching mathematics will be developed based on the codes and themes.

Access and Entry

This study focused on the categories of South Korean elementary teachers' knowledge for teaching mathematics, which is a part of a large mixed-method research study on South Korean elementary teachers' knowledge for teaching mathematics that used 317 South Korean elementary teachers. Permission to conduct research with human subjects was sought by following the procedures through Boston College's Institutional Review Board (IRB). Consent from every participant and the approval letter from the Ministry of Education of South Korea, which administers the school sites where the observation occurred, were obtained. Appendix B includes IRB consent forms for this study. The consent form contained a brief description of the purpose of the study, an explanation regarding how they were identified as participants, and an indication of the time commitment that would be required of them, along with a statement of the potential risks and benefits related to their participation in this study. In signing the informed consent form, the teachers agreed to participate in three interviews, provide a lesson plan for observation and permit a video recording of the observed lesson.

Participants

For this study, 11 participants with teaching experience at the elementary level ranging between 5 to 15 years were selected through the use of a purposive sampling strategy. Purposive sampling requires the researcher to set boundaries that define aspects of the cases connected to the research question (Miles & Huberman, 1994). The criteria for teaching experiences were developed by considering diverse factors that might affect teachers' knowledge for teaching mathematics according to the conceptual framework: teaching experiences, certification, and teacher education program. The fundamental purpose of the study is to understand the categories of South Korean elementary teachers' knowledge for teaching mathematics. Thus, it was feasible to select participants who have more experience and knowledge for teaching mathematics than novice teachers would.

The first rationale for selecting participants was based on the argument that teaching experience might affect elementary teachers' knowledge for teaching mathematics (e.g., Bell, Wilson, Higgins & McCoach, 2010; Li & Huang, 2008). Thus, it was feasible to select elementary teachers who have more teaching experiences than novice teachers have. In particular, Ng (2011) revealed that the relationship between years of teaching experience and teachers' mathematical knowledge for teaching geometry is represented as a quadratic curve rather than linearly. The teachers participating in Ng's study who had teaching experience of between 5 to 15 years had significantly higher mathematical knowledge for teaching than did the other teachers in the study with less than 5 years or more than 15 years of experience. Although Ng did not focus on South Korean Elementary teachers and concentrated on only one area of

mathematics (i.e., geometry), the case study presented in this dissertation set the criteria for teaching experience as ranging between 5 to 15 years. In addition, South Korean elementary teachers may acquire the highest teacher certification after about 5 years of teaching, which is another factor that may affect teachers' knowledge from the conceptual framework. Thus, it may be feasible to select teachers who have more than 5 years of teaching experience for this study.

The second and third rationales used were teacher certification and teacher education programs from the conceptual framework. This study chose participants who had the highest level of elementary teacher certification as well as a master's degree in mathematics education at the elementary school level. The South Korean elementary teachers acquire the Level 2 certification after finishing 4 years of preservice teacher education program. With the Level 2 certification, teachers have the qualification to teach in a private elementary school or to apply for the teacher recruitment examination for public elementary schools. As discussed above, teachers may acquire the Level 1 certification when they complete 180 hours of the national teacher education program with at least 3 to 5 years of teaching experience. With Level 1 certification, teachers may have the qualification to become a head teacher.

This study chose participants who work in Seoul, South Korea, because of its geographical accessibility. Although there are 11 educational districts in Seoul, in terms of the elementary school where the participant works, the location of the school may not be significant because a teacher's quality and teacher distribution are highly controlled by the South Korea Ministry of Education. Also, by law, elementary teachers are required to change schools every 5 years in a province and to change grade levels taught each year.

The educational context and the management system of elementary teachers of South Korea education will be discussed Chapter 4.

Although the location of the school is not noteworthy in terms of teacher distribution, this study chose one teacher from each educational district in Seoul to minimize errors or bias in this study. Yin (1994) proposed that the researcher should consider diverse external components such as geographic differences to ensure reliability of multiple case studies. In addition, one of the study's research questions investigates how South Korean elementary teachers' knowledge for teaching mathematics may influence their mathematics instruction. In this case, teachers' ways of using their knowledge for teaching mathematics might differ according to students' academic levels or backgrounds. For example, recent research suggested that teachers' use of their knowledge might differ according to school settings such as students' sociocultural backgrounds, demographics, and students' mathematics achievement scores (e.g., Hill & Lubienski, 2007; Hill, Rowan & Ball, 2005; Tanase, 2011; Hill, 2008). In order to observe diverse interaction between teachers' knowledge for teaching mathematics and various students, this study selected 11 teachers from 11 educational districts in Seoul.

Detailed descriptions about school and educational context will be presented in the following chapter. Based on these criteria, this study selected 11 teachers who have diverse teaching experience. Every teacher worked at a different elementary school located in Seoul, South Korea. Table 3.1 lists the teachers by pseudonym and summarized brief information on each teacher's background.

Table 3.1.

Information about Participants

Teacher Name	Current Grade Level	Years of Teaching Experience	Teacher Certification	Degree for Mathematics Education
Mrs. Kim	5 th	10	Level 1	Master
Mrs. Jeong	4 th	5	Level 1	Master
Mrs. Yang	1 st	8	Level 1	Master
Mrs. Choi	4 th	10	Level 1	Master
Mrs. Yoon	3 rd	10	Level 1	Master
Mrs. Park	6 th	15	Level 1	Master
Mrs. Lee	4 th	13	Level 1	Master
Mr. Ki	2 nd	11	Level 1	Master
Mr. Ro	5 th	7	Level 1	Master
Mr. Bae	6 th	12	Level 1	Master
Mr. Cho	6 th	10	Level 1	Master

Settings

The setting for this study is Seoul, South Korea, which contains 11 education school districts. In South Korea, elementary teachers teach a variety of subjects, including mathematics. Each lesson usually lasts 40 minutes; however, teachers can adjust lesson time based on a subject. All lessons must be prepared based on the National Mathematics Curriculum in regard to the sequence of the content. However, a detailed description of South Korean mathematics curriculum and the social context will be presented in Chapter 4.

Mrs. Kim has been teaching mathematics since 2002, and her placement was in a fifth-grade classroom. Mrs. Kim's classroom consisted of forty-two 11-year-old Korean students. Among them, 21 students were male, and 21 students were female. All of the students participated in the observed lesson. According to the information provided by the teacher, most of the students were from middle-class backgrounds. Among them, 37 students received extra mathematics lessons from private institutions or tutors, although

none of these students had any difficulties learning mathematics. In fact, almost 90% of the students usually receive As or A-minuses on their mathematics tests.

During the observed lesson, Mrs. Kim taught students how to draw a sketch of a rectangular parallelepiped. Two previous lessons focused on basic concepts of a rectangular parallelepiped. According to the participant's own survey on her teaching, 34 students answered that they had already learned about it before the lesson. However, when Mrs. Kim carried out diagnostic assessments, she found that 28 students did not understand the basic concepts of a sketch of rectangular parallelepiped well, although they had learned it already and knew how to draw it. According to Mrs. Kim's explanation, most of her students have instrumental understanding rather than relational understanding about a sketch of a rectangular parallelepiped.

Mrs. Jeong is in her fourth year of teaching, and she is teaching in a fourth-grade classroom. There are thirty-four 10-year-old Korean students in her classroom. Among them, 19 students are male, and 15 students are females. All of the students participated in the observed lesson. According to the information provided by the teacher, most of the students were from middle-class backgrounds. Among them, 28 students received extra mathematics lessons from private institutions or tutors. Mrs. Jeong's classroom consisted of students who have diverse mathematics abilities. According to Mrs. Jeong's report, 30% of students received high achievement scores on their previous mathematics tests, 60% were average, and the rest of the students received lower than average achievement scores.

During the observed lesson, Mrs. Jeong taught students the basic concepts of a trapezoid. It was the first lesson of the chapter about diverse shapes of a quadrangle. The

participant's own survey of her teaching stated that students who receive extra lessons from a private institution or tutors said they had already learned about the basic concepts of a trapezoid. However, based on diagnostic assessments, Mrs. Jeong found that only 10 students knew the basic concepts of a trapezoid correctly.

Mrs. Yang has been teaching for 8 years. Her placement was a first-grade classroom of 16 male students and sixteen female students. All of the students were 7-years old, and they all participated in the observed lesson. Most of the students were from middle-class backgrounds. None of them received extra mathematics lessons from private institutions or tutors. Mrs. Yang explained that students in lower grades do not typically receive extra mathematics lessons.

Mrs. Yang taught students how to count two-digit numbers during the observation. Five previous lessons concentrated on how to count and write one-digit numbers. The participant's own survey of her teaching stated that all students answered that they already knew how to count two-digit numbers. Students had learned how to count these numbers from their parents.

Mrs. Choi has been teaching mathematics since 2002. Her placement was in a sixth-grade classroom. Mrs. Choi's classroom consisted of twenty-six 11-year-old Korean students. Among them, 15 students were males, and eleven students were females. All of the students participated in the observed lesson. According to the information provided by the teacher, most of the students were from a lower socioeconomic background and obtained lower grades on previous mathematics achievement tests. Among them, 20 students had received extra mathematics lessons from private institutions or tutors.

During the observed lesson, Mrs. Choi supported students as they explored shapes constructed from cubes to find the number of cubes contained in that shape. One previous lesson focused on building diverse shapes with a numbers of cubes. The participant's own survey of her teaching stated that 34 students answered that they had already learned about this topic before the lesson. However, when Mrs. Choi carried out diagnostic assessments, she found that most students did not know the strategies to find the numbers of cubes.

Mrs. Yoon has 10 years of teaching experience in an elementary school. Currently, Mrs. Yoon works as a homeroom teacher in a third-grade classroom. She has twenty-eight 9-year-old students in her classroom; 16 are males, and 12 are females. All of the students participated in the observed lesson. According to Mrs. Yoon, most of the students were from a lower socioeconomic background. However, students' previous mathematics achievement test results were higher than average. Among the students, 15 students had received extra mathematics lessons from private institutions or tutors.

Mrs. Yoon taught the relationship between a millimeter and a centimeter during the observed lesson. It was the first lesson of the chapter that covered units of length and time. Mrs. Yoon knew that most of her students already knew the relationship between millimeters and centimeters before her lesson. From her own survey, it was revealed that most students had said they had already learned about the units of length from private institutions or their parents. Therefore, she planed the lesson, which focused more on the needs of units of lengths rather than on measuring skills.

Mrs. Park is an elementary teacher who has 15 years of teaching experience. She teaches 36 sixth-grade students as a homeroom teacher. Her classroom consisted of 20

males students and 16 female students. All of the students participated in the observed lesson. Based on Mrs. Park's report, most of the students were from a lower socioeconomic background, and students had shown lower mathematics achievement than average on previous mathematics achievement tests. However, more than 80% of students had received extra mathematics lessons from private institutions or tutors, and some had already had learned middle school mathematics content from their private institutions.

Mrs. Park's lesson was about the sketch of a cylinder. Mrs. Park had already taught the basic concepts of cylinder and the relationship between cylinder and cubes before the observed lesson. According to Mrs. Park, most of her students had already learned about mathematics content covered by elementary mathematics curriculum from their private institutions or tutors, although most of the students were from a lower socioeconomic background.

Mrs. Lee is in her 13th year of teaching in an elementary school, and she is working as a homeroom teacher in a third-grade classroom. Mrs. Lee's classroom consisted of 31 nine-year-old students. Among them, 16 students were male, and 15 students were females. All of the students participated in the observed lesson. The information provided by Mrs. Lee stated that the students were from a middle-class background. Among them, 14 students received extra mathematics lessons from private institutions or tutors, although none of them had any difficulties learning mathematics.

During the observed lesson, Mrs. Lee taught students about centimeter squared (cm^2) as the unit of area. It was the first lesson of the chapter, which covered diverse units of area and the ways of calculating areas of various two-dimensional shapes. Mrs. Lee's

own survey of her teaching stated that 20 students stated that they had already learned about it before the lesson.

Mr. Ki is a homeroom teacher in a fourth-grade classroom and is in his 11th year of teaching. Although his elementary school is a public elementary one, it was established as a research lab school. The Seoul Metropolitan Office of Education selects teachers and students for the school. Mr. Ki had 14 male students and 16 female students in his classroom. All students are 11-years old, and all of them participated in the observed lesson.

Mr. Ki taught diverse ways of adding and subtracting two-digit numbers during the observed lesson. Three previous lessons were conducted that had focused on how to add and subtract two-digit numbers. Most of the students were from a middle-class background and had received high achievement scores on their previous mathematics tests. Although most of students had not received extra mathematics lessons from private institutions or tutor, they usually prepare mathematics lessons with their parents.

Mr. Ro is in his 12th year of teaching, and he is a homeroom teacher in a fifth-grade classroom. He has thirty 11-year-old students in his classroom. Among them, 16 students were males, and fourteen were females. All of the students participated in the observed lesson. According to Mr. Ro's report, most of the students had received extra mathematics lessons from private institutions or tutors, although the students were from a low-socioeconomic background. However, most of the students' achievement scores on previous mathematics tests were just above average.

During the observation, Mr. Ro focused on basic concepts of cubes. It was a first lesson of a chapter that covers diverse types of three-dimensional shapes. From Mr. Ro's

own survey of his teaching, it was revealed that 90% of students answered that they had already learned about it before the lesson. However, when Mr. Ro carried out interviews with some students, he found out his students just memorize the definition of properties of a cube rather than understand the relationship among properties.

Mr. Bae has been teaching mathematics in an elementary school since 2005. Mr. Bae's placement was in a sixth-grade classroom that consisted of 15 male students and 12 female students. All of the students were 12-years-old, and they all participated in the observed lesson. From the information provided by the teacher, it was revealed that most of the students were from a middle-class background. Most of the students had received extra mathematics lessons from private institutions or tutors, and almost 90% of the students had usually received As or A minuses on their mathematics tests.

During the observed lesson, Mr. Bae taught students the relationship between the diameter and circumference of a circle. It was the first lesson of the chapter that focused on the ratio of the circumference of a circle to its diameter and area of a circle. According to the participant's own survey of his teaching, 22 students answered that they had already learned about this concept before the lesson. Some of the students knew the mathematical term; pi (π), although students do not usually learn about pi until middle school. However, Mr. Bae found that students just memorized the ratio of pi rather than showed an understanding of the relationship between the circumference of a circle and its diameter.

Mr. Cho also has been teaching mathematics since 2002. His placement was in a sixth-grade classroom that consisted of forty-one 13-year-old Korean students. Among them, 22 students were males, and 19 students were females. All of the students

participated in the observed lesson. According to the information provided by the teacher, most of the students were from a middle-class background. Among them, 34 students had received extra mathematics lessons from private institutions or tutors, although none of them had had any difficulties learning mathematics.

During the observed lesson, Mr. Cho taught students how to draw the shape of wooden cubes seen from above, the front, and the sides. Three previous lessons focused on developing spatial sense using wooden cubes. According to the participant's own survey of his teaching, 32 students answered that they had already learned about it before the lesson. When Mr. Cho carried out diagnostic assessments, he found that these students knew how to draw a shape of wooden cubes seen from above, the front, and the sides. According to Mr. Cho's explanation, most of his students already knew what they were supposed to learn during the lesson, thus he needed to find new ways of maintaining students' interests during the lesson.

Although students' level, grade, and background varied from case to case, such as the mathematics topics during the observed lesson, there is a common element across the classrooms. Many students in the participants' classrooms had received extra mathematics lessons from a private institutions or tutors. All participants pointed out this phenomenon causes problems in a school's mathematics classroom. The participants perceived that the private institutions and tutors only focused on students' instrumental understanding in order to improve students' mathematics test scores. The participants distinguished themselves from the private institutions and tutors by stating that they as teachers pursue relational understanding in mathematics education. This information illustrates some aspects of contexts affecting the teaching of the participants in this study.

Chapter 4 provides more detailed information about the social context of the South Korea education system.

Data Collection

The process of data collection and analysis occurred concurrently, based on grounded theory: Data were analyzed as they were collected, and the analysis affected the process of future data gathering. However, a description of the process of data collection and analysis will be presented independently for clarity purposes in this section.

The aim of the study presented in this paper is to explore knowledge for teaching mathematics of South Korean elementary schoolteachers. An in-depth multiple-case-studies approach was applied to examine knowledge for teaching mathematics that influences teachers' instructional process, including an analysis of diverse artifacts such as interviews, lesson plans, and observations. The multiple-case approach increases the validity and the stability of findings (Miles & Huberman, 1994).

Interviews

The data sources included three interviews of the practicing South Korean elementary schoolteachers. The relationship between the interview questions and the frameworks are as shown in Table 3.2.

Table 3.2.

Relationship Between Components and the Interview Questions

Framework	Components		*Interview (Question)
Theoretical Orientation	Verbal/Nonverbal Language		H2, H4, H5, H6, E8, E9, E11
	Understanding Students' Learning Based on the Schema		H3, H5, H6, H7, E1, E2, E3, E4, E5, E6, E7, E10
Conceptual Framework	What are the Affects on Elementary Teachers' Pedagogical Content Knowledge in Mathematics	Teaching Experience	B1, B2, B3, B4
		Education Program	G1, G2
		Mathematics Content Knowledge	H1, H4, H7
		Beliefs about Mathematics Education	F1, F2, F3, F4, F5
	Process of Instruction	To Prepare Mathematics Lessons	C1, C2, C3, C4, C5, C6, C7
		To Teach Mathematics Lessons	D1, D2, D3, D4
		To Assess Students' Learning	E1, E2, E3, E4

*Note. This column represents the interview questions. For example, H2 represents question number *H2*. For a complete review of the questions, see Appendix C.

The study used semistructured interviews to help answer the major research question. The first interview gathered biographical data about the participants' educational backgrounds. The second interview focused on the participants' knowledge for teaching mathematics using students' works. The second interview was an adaptation of a questionnaire developed by Ball (1988). The third interview contained subsequent questions about the observations of the participants' teaching for understanding and on the participants' perspectives and to clarify their intentions within the context of their teaching.

Observations

A second data source consisted of a 40-minute classroom observation of each of the 11 South Korean elementary teachers by the researcher of the study, whereby the video equipment was placed in the back of the classroom. I analyzed one videotaped-observation with an intensive interview about it in order to present a detailed description of the teacher's use of knowledge for teaching mathematics in one lesson. The collected data from field notes will enrich and complicate our understanding of the interview data because, as Rossman and Rails (2003) observed, the participants' actions can be "purposeful and expressive of [their] deeper values and beliefs (p.195)."

Lesson plans

A final data source contained an analysis of the teachers' lesson plans developed for the lesson to be observed. Analyses of lesson plans can provide insights into how teachers conceive and plan their lessons (Leinhardt, 1993; Stigler, Fernandez & Yoshida, 1996). Teachers' educational purposes may not be observed in the records of instruction, thus analysis of lesson plans might be needed when the researcher observes the classroom teaching or use videotapes of it (Cai, 2005). The teachers in this study submitted two lesson plans; one plan was for the observed lesson, and the other one was any lesson plan that the teachers had available. I requested the second lesson plan to compare common aspects between lesson plans. Therefore, this study included the analysis of 22 lesson plans of 11 South Korean elementary teachers whom I observed based on the theoretical orientation and the conceptual framework.

Procedures

Before the first interview, each participant was informed about the purpose and process of this study before he or she decided to participate in this study. The participants were required to participate in three interviews and to provide one lesson plan for the observed lesson. Two 90-minute interviews were conducted before the classroom observation. Before the observation, the teachers developed a lesson plan in their own style, following the National Mathematics Curriculum Guidelines. For the observed lesson by the researcher, the video camera was located in the back of the classroom, and only the teacher and his or her students were present during the taping of the lesson. During the observations, written notes were taken by the observer to record nonverbal communication as well as information written on the chalkboards and projected on the screen, which was connected to a desktop computer. After the observation, a 90-minute interview was conducted with each participant about his or her lesson plan and teaching. One researcher transcribed all the interviews and the observations.

Data Analysis

The process of data collection and analysis of it happened simultaneously. As data was collected, they were converted into electronic documents. I transcribed raw data that I had collected from interviews, observations, and lesson plans by using the Excel program. The transcriptions were transcribed on a line-by-line basis because a line-by-line transcription is useful to represent data as objectively as possible in an early stage of data analysis (Charmaz, 2000). In addition, every line was assigned a short descriptor intended to represent its fundamental meaning.

In the next phase of analysis, I looked for patterns or connections within the data. The data were analyzed separately according to the sources; for example, the transcripts from the classroom observations of the 11 participants were analyzed and coded together to identify generalizable initial codes. In this stage, I used axial coding in order to find a relationship among raw codes. Axial coding in grounded theory is the process of connecting codes to each other (Strauss & Corbin, 1990). With the theoretical orientation and conceptual framework, I searched the raw codes generated from the first stage of analysis to find themes that seemed to be interrelated; I read transcripts several times to identify initial codes. After developing a coding frame with initial codes, the researcher coded the transcripts. If new codes emerged, the coding frame was changed, and the transcripts were reread according to the new structure. While I was comparing themes, when properties emerged, they were integrated together. This process was used to develop themes, which were categorized into five components. The results of this study reports on these five themes: Mathematics Curriculum Knowledge, Mathematics Learner Knowledge, Fundamental Mathematics Conceptual Knowledge, Mathematics Pedagogical Content Knowledge, and Mathematics Pedagogical Procedural Knowledge. Some of the generated themes have subthemes. For example, Mathematics Curriculum Knowledge consists of two subthemes: vertical mathematics curriculum knowledge and horizontal mathematics curriculum knowledge. Figure 3.1 demonstrates the process of generating the themes for this study.

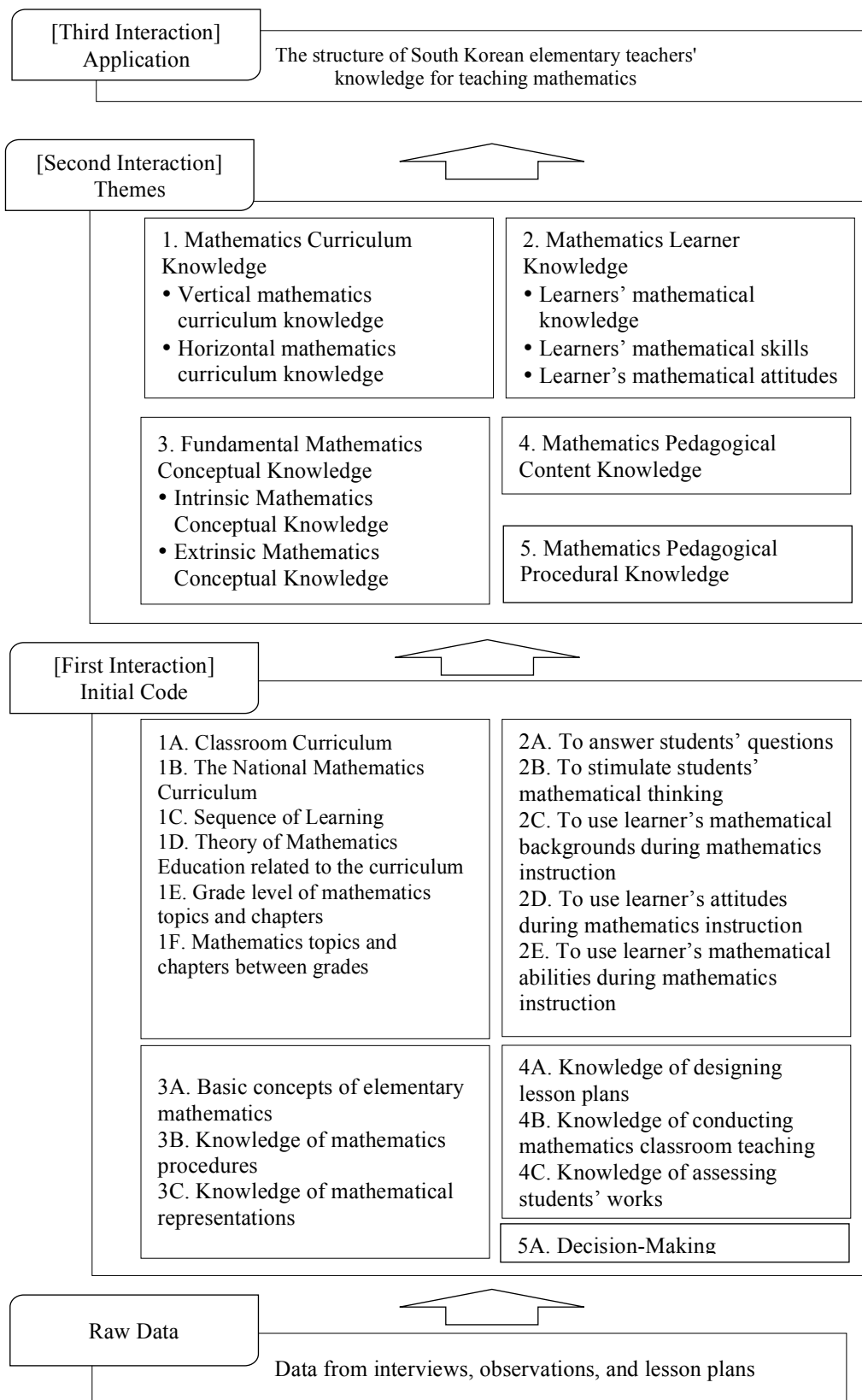

Figure 3.1. The Process of Organizing Data

In order to prevent researcher's bias, I used *member checking* strategies and data triangulation. Through the process of *member checking*, I presented draft materials to participants for confirmation and further illumination; this may help the researchers triangulate observations and interpretations (Stake, 1995, p.115). Thus, the participants in this study were requested to examine rough drafts of writings for interpretive validity. In this study, I used the excerpts from the interviews or observations as evidence to generate each theme. Thus, the teacher's confirmation was needed in order to ensure the researcher interpreted the participants' intentions about their knowledge properly. For example, I used the following excerpt to generate Mathematics Learner Knowledge initially in this study.

Mrs. Kim: Student should have learned the basic concept of parallel lines in order to participate in today's lesson.

However, after Mrs. Kim examined the data, she reported that she also wanted to emphasize her knowledge of Mathematics Curriculum; Mrs. Kim knew the sequence of the mathematics topics were based on the National Mathematics Curriculum, thus she could find what students should have already learned prior to learning the new topic. In this case, the excerpt was also coded as Mathematics Curriculum Knowledge.

In addition, with generated themes from the second phase of data analysis, I established a frame for data sources in order to analyze each participant's data. Table 3.1 demonstrates the major findings of this study listed under five categories and the three sources of data collection. Every data source offers corroborative proofs to verify information obtained by each method. All findings listed in Table 3.3 were corroborated by at least one other source of data. The use of multiple sources of data collection as a

form of triangulation avoids reliance exclusively on a single data collection and thus defuses any bias inherent in a particular data source in qualitative research (Anfara, Brown, & Mangione, 2002).

Table 3.3.

Findings and Data Triangulation

Major Findings	Source of data				
	I1*	I2	I3	O	L
Theme 1: South Korean elementary teachers' mathematics curriculum knowledge					
1. Vertical mathematics curriculum knowledge	×	×	×	×	×
2. Horizontal mathematics curriculum knowledge	×	×	×	×	×
Theme 2: South Korean teachers' mathematics learner knowledge					
1. Learners' mathematical knowledge		×	×	×	×
2. Learners' mathematical skills		×	×		×
3. Learners' mathematical attitude		×	×	×	×
Theme 3: South Korean teachers' fundamental mathematics conceptual knowledge					
1. Intrinsic mathematics conceptual knowledge		×	×	×	×
2. Extrinsic mathematics conceptual knowledge		×	×	×	×
Theme 4: South Korean elementary teachers' mathematics pedagogical content knowledge					
		×		×	×
Theme 5: South Korean elementary teachers' mathematics pedagogical procedural knowledge					
		×		×	×

* I: Interview, O: Observation, L: Lesson Plans

With this process, the ultimate theory will be developed from the ground up. From the data that I collected, I found five themes of South Korean elementary teachers' knowledge in mathematics: Mathematics Curriculum Knowledge, Mathematics Learner Knowledge, Fundamental Mathematics Conceptual Knowledge, Mathematics Pedagogical Content Knowledge, and Mathematics Pedagogical Procedural Knowledge. The detailed description of each theme will be discussed in Chapters 5 through 8.

Limitation of the study

It is important to acknowledge that a possible limitation of this study is that the findings may not be generalized to all cases of South Korean teachers, although this study focused on 11 cases of teachers by examining several artifacts (e.g., lesson plan, observation, interviews). According to Yin (1993), the purpose of multiple case studies analysis is not to gather sample for generalization. Rather, the goal of multiple case studies analysis is to seek analytical meaning that penetrates each case. Therefore, it might be hard to say that the findings in 11 case studies are not much more robust than what could have been obtained with only couple of cases (Baucus & Human, 1994). The present sample of 11 teachers will be selected based on the purpose of this study, with the recognition that analytical meaning of the cases could be vigorous by adjusting the number of cases. Although the findings of this study will not be generalizable through a statistical procedure orientation, it is intended to consider the interconnected notions of generalizability utilized in qualitative research: credibility, transferability, dependability, and conformability (Lincoln & Guba, 1983).

This study will attempt to select representative participants and analyze their knowledge for teaching mathematics based on grounded theory. Although I endeavored to design a comprehensive study, another limitation of this study will be that one researcher interpreted the data and finding of this study. However, diverse qualitative research methods such as member checking and data triangulation might help the researcher improve accuracy, credibility, validity, and transferability in this study (Stake, 1995). Readers are encouraged to consider this limitation of the study when they evaluate this study's worth in the context of the wider academic field.

Researcher Positionality

This study applied a qualitative approach in order to reveal the types of elementary teachers' knowledge for teaching mathematics. Qualitative researchers should try to be as objective as possible just like quantitative researchers (Geertz, 1983). However, in qualitative research, the researchers may value their unique perspective as a source of understanding and systematically reflect on who he or she is (Rossman & Rallis, 2003). Assuming that my experience and position may influence the way I collected and interpreted this study's data, some comments are presented below.

I was born and grew up in Seoul, South Korea. In 2002, the moment I passed the Seoul Metropolitan City national schoolteacher certification exam and became an elementary schoolteacher, I enrolled in graduate school to study mathematics. In my study of mathematics education, I was introduced to Richard R. Skemp's research. Skemp's research presented problems of teaching and learning mathematics from both a psychological and mathematical position. As I developed my understanding of Skemp's perspective, I acquired a new point of view on mathematical comprehension processes and perception structures of students. Through the study on problem solving, I became interested in the systematic approach to problems, which is the major core of mathematics education.

After completing my masters' degree in 2010, I lectured at Seoul National University of Education with a theme of "instructional methods for elementary mathematics education." I also continued to share what I had learned with teachers as an instructor of various training programs, and I became the author of the National Math Textbook in 2009.

Although I was always busy studying better ways to teach mathematics, I continued to gain a greater perspective as a teacher and to improve my knowledge of mathematics education. Therefore, in 2003 I traveled abroad to visit an elementary school in Japan. In 2004 and 2005, for 2 months, I worked as an exchange teacher at a public elementary school in Australia. I was also one of eleven teachers selected by the Seoul Metropolitan Office of Education in 2007 to go to England for 1 month for English language training. Again in 2009, the Seoul Metropolitan Office of Education selected me to participate in the National Council of Teachers of Mathematics Annual Meeting held in Washington, D.C. Through these experiences, I gathered various materials in the field I am researching, and I realized that mathematics education in the United States and mathematics education in Korea shared various aspects for mutual improvement. Accordingly, I decided to research mathematics education further in the United States. In 2011, I started my doctoral degree at Boston College in the United States.

Therefore, I had a basic understanding about the South Korean National Mathematics Curriculum at the elementary level, general mathematics education theory, and manipulatives. My background as a mathematics educator in South Korea may affect the process of analyzing data that I collected from the participants; I could notice an underlying meaning of their teaching based on their cultural background and examine their lessons with the theory of mathematics education.

CHAPTER 4

Context of Elementary Mathematics Education in South Korea

As noted in the previous chapter, the findings should be discussed in the context of the educational setting in South Korea, as a qualitative approach needs appropriate interpretations about specific surroundings (Erickson, 1986). However, it may not be feasible to attempt to discuss every aspect of the educational context of one country in one chapter. Thus, the chapter will only focus on characteristics of the educational context of South Korea that relate to interpreting and understanding data acquired from interviews, observations, and the lesson plans.

This chapter starts with the discussion about the characteristics of the national curriculum in South Korea. As noted in Chapter 3, the education system at the elementary level is highly controlled by the South Korean government, and the national curriculum plays a pivotal role in the government's regulations. This section includes information about how the government regulated the quality of education within the national curriculum. This section provides a general understanding of the South Korea education system at the elementary level and the reason the location of the schools where the participants work is not significant in this study as noted in Chapter 3.

The second section of this chapter is about *Education Fever* in South Korea. Education fever refers to the phenomena of high-profile education in South Korea (Seth, 2002). A discussion of education in South Korea is not complete without mentioning *Education Fever* (Sorensen, 1994). Although this study focused on South Korean elementary teachers' knowledge for teaching mathematics, it may be hard to understand the context of participants' classroom teaching without developing an initial

understanding of education fever. By analyzing socio-historical background of education fever, this section may broaden our understanding regarding the classroom setting in this study.

The last section of this chapter is about the characteristics of the National Mathematics Curriculum. Because the teachers' knowledge concerning the National Mathematics Curriculum will be discussed as one of the major categories of South Korean elementary teachers' knowledge for teaching mathematics in Chapter 5, it is critical to understand the characteristics of the National Mathematics Curriculum. In addition, discussions on how the National Mathematics Curriculum is organized are needed because the participants' lesson plans and classroom teaching were constructed based on the National Mathematics Curriculum.

The National Curriculum in South Korea

There are several approaches to classifying curriculum; curriculum might be classified into the discipline-centered, the experience-centered, and the subject-centered curriculum according to content of curriculum (e.g., Popkewitz, 1977; Broad, 1949; Gerald, 1949). On the other hand, curriculum may be divided into the central-based and school-based curriculum according to the decision makers for development or propagation of curriculum (e.g., CERI, 1979; Marsh, 1990). The national curriculum of South Korea might be considered a combination of the discipline-centered curriculum and the central-based curriculum. However, this may not be enough to explain the national curriculum of South Korea, because the government is deeply involved in the application of the national curriculum. In order to clarify the government's intervention, I shall divide the process of managing curriculum into three stages: development,

propagation, and implementation. The development process indicates the decision about the subjects and their curriculum contents. The propagation process is related to the development and the decision about a range of applications. Implementation refers to practical decisions related the application of the curriculum, such as deciding the school days, organizing the order of students' learning sequence and division of time for each subject, and choosing textbooks or teachers.

Based on this classification, I suggest we need a new perspective on the curriculum in order to understand the national curriculum of South Korea. In this model (Figure 4.1 below), I classify curriculum based on who the decision maker is in the managing process of curriculum: the government-regulated curriculum, the coregulated curriculum, and the school-regulated curriculum.

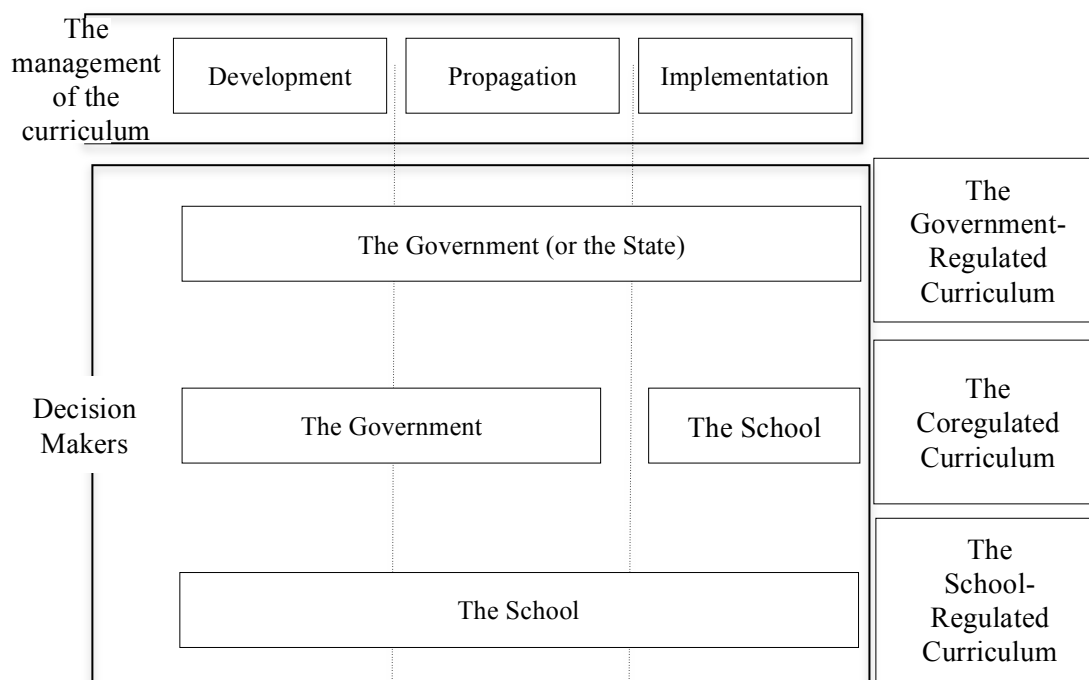

Figure 4.4. Diverse Managing Process of the Curriculum

The U.S. curriculum was or is a school-regulated curriculum. The implementation of the Common Core State Standards (CCSS) may change it into a coregulated curriculum. Unlike America, South Korea uses a government-regulated curriculum.

The South Korean government has a vital role in developing and managing the national curriculum for both public and private schools. Moreover, the South Korean government developed an efficient system in which to convey the content of the national curriculum to students. The government decides the content and organization of the national curriculum. Based on the national curriculum, the government develops the textbooks and issues them to all elementary students in South Korea for free. Although in middle schools and high schools there is a fee for textbooks, students can only use the textbooks that are authorized by the Ministry of Education. Not only that, but the government also provides free highly detailed guidebooks to all teachers, which contain short lesson plans, teaching methods, teaching materials, and an assessment approach for each lesson. Teachers must teach according to the national curriculum because the government hires teachers and regulates their teaching by law. The quality and the distribution of teachers also are highly controlled by the government. For example, there are only 13 universities that offer preservice education program for those interested in becoming elementary school teachers. In addition, the educational law specifies school days and hours for each subject. Every time the government amends the national curriculum, the government provides new textbooks to students and guidebooks to teachers. The teachers must understand the new national curriculum and the ways of teaching it through teacher education programs that are also supported by the government. This indicates that all elementary students in South Korea have to learn almost the same

content based on the national curriculum in similar ways in their 6 years of compulsory education. Therefore, it appears that the national curriculum is a powerful influence on the educational field in South Korea, more so than is true in other countries. This simply implies that students can learn the same content provided by the government; students may develop the same values and conscience that are oriented by the national curriculum. For example, Min (1998) proposed that students' views toward occupation had changed according to the change in the national curriculum in 1992. Moon and Kwan (2006) suggested high school students' viewpoints toward the nature of science altered according to the amendment of the national curriculum in 2000.

Despite concerns about standardized education, the national curriculum of South Korea is highly controlled in every aspect as noted above. To understand why this educational regulation via the national curriculum is socially accepted in South Korea, I focused on the history of how the government established the national curriculum based on the assumption that the process of designing curriculum is not neutral (e.g., Wensbury, 2008; Erickson, 2008; Nietro, Bode, Kang, & Raible, 2008). These points of views might offer some clues for understanding how socio-cultural effects influence the curriculum. Although this study does not purpose to analyze the historical background of the national curriculum in South Korea, the examination of the historical context of the national curriculum is needed to understand the context of educational setting in South Korea.

The modern South Korean curriculum was introduced toward the end of World War II. At that time, Korea was an absolute monarchy until Korea was annexed by Japan in 1910. After Japan invaded Korea, Japan established a modern education system in Korea based on colonial education. The most fundamental goal of Japanese colonial

education was to keep the Koreans ignorant to make them easy to rule (송광성, 1993). Japan obstructed learning opportunities for Koreans. The Japanese only provided vocational education and allowed higher education to the elite group that was loyal to Japanese imperialism (손호철, 1995). Needless to say, the way of teaching was militaristic and through coercion. According to the research (e.g., 이명화, 2001; 반민족연구소, 1994), the South Korean education system still has the remnants of colonial education. Notable examples of the colonial legacy are as follows.

First, the national curriculum is highly controlled by the government in South Korea. The Ministry of Education enacted strict laws about content and objectives of curriculum and forced teachers to teach based on the national curriculum (반민족문제연구소, 1993). The Ministry of Education is in charge of the whole range of school education, including textbooks, teachers, and school management. By taking advantage of this system, the government distorted the truth or chose educational content selectively according to national ideology (강창일, 2002). The Ministry of Education did not introduce most pro-democracy movements or described them as riots in the textbooks during the military regimes of the 1970s and the 1980s in South Korea (조이스롤코, 1985). The government's views on education in terms of control are paralleled to the colonial educational system that was dominated by government decisions.

Second, the basic premise of the national curriculum in South Korea was to select people who could contribute to the development of society, and this caused excessive competition among students (이명화, 2011). Japan provided the chance to participate in higher education to only a few Koreans and made them take part in their colonial rule.

Limited opportunity to participate in higher education caused rivalry among Korean students, and this competition still exists today in South Korea (정준영, 2011). However, the biggest problem is that the South Korean government has maintained this point of view regarding school education. The educational policy that urged students to be overly competitive has been taken for granted not only because of the colonial legacy but also due to reconstruction of the nation after the Korean War. The South Korean government enforced the middle school entrance examination until 1969 and provided middle school education only to students who had passed this exam (하윤수, 2009). Until the 1990s, middle school students who had low grade-point averages were forced to go to vocational education high schools (임천순, 1997). There still remains high schools that require the entrance examination, which encourages elitism in South Korea, which gives rise to a strong sense of rivalry among students.

Although recent studies suggest that the national curriculum in South Korea might consist of remnants of colonial education as discussed above, the national curriculum also has some merits. According to the Seoul Metropolitan Education Office (2012), there are 594 elementary schools in Seoul. Among them, there are only 42 private elementary schools. Except students who want to go to private schools, students are assigned to elementary schools based on the locations of their homes. The purpose of the national curriculum and the regulated education in South Korea is to provide the same content and quality of education to every elementary student regardless of his or her residential area. In addition, the highly qualified teacher education system and the government's effort to maintain the quality of teachers might be an effective way to improve the quality of school education.

The discussions in this section are expected to broaden the understanding of research methods and discussion of findings in this study. From Chapter 3, this study selected participants based on the assumption that the district where the school is located might not affect the teachers' knowledge for teaching mathematics. The highly regulated educational system via the national curriculum in South Korea provides a basis for the decision-making process for selecting participants in this study. Also, this study did not consider the participants' teaching materials such as textbooks or mathematics manipulatives, as the teachers and their students use the same type of mathematics textbooks and teacher guidebook that the government provides. The next section includes an analysis of education fever in South Korea. The information from the following section provides the basis for understanding the classroom setting and students' characteristics in this study.

The National Curriculum and Education Fever in South Korea

From Chapter 3, the teachers provided information about their students' prior learning from private institutions or tutors before they learn the mathematics topic in their school classroom. The results of the analysis of data suggest that students' prior learning affected the teachers' ways of developing lesson plans; these findings will be presented in Chapter 6. The teachers also reported that students' prior learning might cause problems in mathematics learning in school, as most private institutions or tutors might focus on the scores from the evaluation rather than on students' conceptual understanding on mathematics topics. From Chapter 6, the teachers described that students who only learned the ways to solve mathematics problems tended not to put much effort into

understanding mathematical structures of problems. Thus, the teachers needed to develop mathematics activities that might help these students.

Korean elementary students' excessive prior learning or private tutoring in mathematics should be understood in the context of education fever in Korean society (박혜인, 1994). Therefore, I focused on education fever to understand the teachers' knowledge that may relate to these students characteristics as well as to educational settings in South Korea. Although I proposed to understand South Korean elementary teachers' knowledge for teaching mathematics, I expect that the discussion regarding education fever in this section will broaden our understanding of the educational context of South Korea along with the findings in this study.

In the next section, I examined education fever based on students' perception of the national curriculum. Their perception is grounded in the assumption that curriculum is not neutral but rather a cultural artifact (Ladson-Billings & Brown, 2008) and that the national curriculum in South Korea has a huge effect on classroom teaching in a school. Their perception of the national curriculum is examined based on socio-cultural background or historical context, as it is expected to broaden our understanding regarding the cause of education fever rather than to provide descriptions of the current education phenomena.

South Korean students perceive the national curriculum as the key means to achieve social success. In addition, most students believe that they have to participate in this limitless competition at schools (김혜숙, 한대동&오경희, 2011). What made them believe that the national curriculum is the road to success? '*The Diploma Disease*' (Dore,

1975, p.141) and Confucianism might provide some clues for explaining students' perceptions of curriculum and education.

Dore (1975) suggested that the diploma disease could be found among the nations that went through government-centered modernization. In those countries, such as Tanzania, Japan, or Sri Lanka, people did not voluntarily participate in the process of modernization. Also, these countries did not have enough time to raise workers and develop new standards for modern society. Therefore, educational certification became the new standard by which to employ new workers, and sometimes it is regarded as more noteworthy than a person's actual ability (Dore, 1975). People tend to try to get high educational certification to prove their ability in those countries.

South Korea might be suffering from diploma disease. South Korea has rapidly modernized itself in the last 50 years after the Japanese Ruling Era (1910–1945) and the Korean War (1950–1953). Until South Korea was invaded by Japan, it was an absolute monarchy, which had a rigid caste system. Due to the Korean War and modernization, the customary caste system began to collapse, and there was an increase in the upward mobility of lower- and middle-class groups with higher education levels. Therefore, educational certification became a passport to success in South Korea. Students are willing to study and sacrifice their school days to go to the university and to get certification. These students' tacit consent does not mean their participation is based on their joy of learning. Students' have no choice but to study because of a strict code of social rules based on Neo-Confucianism.

Neo-Confucianism was the ruling principle for about 500 years in South Korea before the Japanese Ruling Era, and it has deep roots in South Korea (Lee, 1999). Neo-

Confucianism is a social and ethical philosophy that originated with Han Yu and Li Ao in the Tang Dynasty, an ancient nation in China (Junwei & Alan, 2011). Neo-Confucianism in South Korea differs from what is found in China because it was the ruling ideology (강신표, 1981); Neo-Confucianism in South Korea was a social philosophy for only about the top 15% of the ruling caste (강창동, 1966). It exceedingly emphasized the principles of loyalty and filial piety in order to maintain the caste system and royal power. The principles of loyalty and filial piety indicate the relationship between people of dominance and their subordinates. Based on Neo-Confucianism, the basic four social classes were the lowly, commoner, nobility, and the royal family. Movement among classes was highly forbidden, and marriage was allowed only within the same class. Grounded in this classification, there were subclasses according to one's occupation. The lowly were divided into slaves and the humble who had the lowliest of occupations, such as butchers. There were also subclassifications within the commoner group, and the classes of work groups were the agricultural, industrial, and mercantile group in order of "importance." The nobility had a chance to learn how to read and write. However, this group also was classified into two subgroups of scholars and soldiers, and scholars were usually respected more than soldiers were. As modernization progressed, the hereditary peerages based on the monarchy begin to disappear.

These subclassifications based on occupations remain in today's South Korean society (김경근, 1996). There are still high and low jobs in South Koreans' perspective, regardless of wages, and South Koreans prefer white-collar jobs to blue-collar jobs. Nakamura (2005) points out that these preferences for certain types of jobs make South Korea's education fever higher than that found in Japan, although Japan and South Korea

have similar cultural and educational backgrounds, including having a national curriculum. Students in South Korea believe that academic achievement in their schooldays could profoundly affect their career choices. They study extremely hard so as not to be relegated to “lower” jobs. The national curriculum is the means to obtain higher jobs for students, thus influencing students’ performances on test in which they memorize content to earn high scores on their tests.

The problem is that the standardized discipline-centered curriculum continues to reinforce students’ beliefs about this distorted work ethic. As the government emphasizes what knowledge is important in the national curriculum, South Korean society cannot escape from the vicious cycle of distorted job perception. According to OECD (2010), the rate of people in South Korea who had a higher education was up to 58% in South Korea; this rate was the highest in the world. The entrance rate of college was up to 71% in 2008, although the OECD average was 56%. On the other hand, the employment rate of people with higher education is over 88.9%, and this rate is lower than the OECD average of 89.8%. Among them, the employment rate for women is 60.7%, and this is significantly lower than the OECD average of 79.9%. At that time, up to 50% of small and medium enterprises were struggling because they could not find workers, as nobody wanted to work in a small company or a factory, and the circumstances in rural areas were more serious (인천상공회의소, 2012). This might show that students who have studied the same curriculum may impose the predominant social values. Even worse, they are the future stakeholders or decision makers; they might force their children to study in the same ways they were forced to study.

According to a recent survey in South Korea (Kim, 2012), 94% of first-grade students had prior mathematics learning experience before they entered elementary school. Thus, South Korean elementary teachers faced teaching mathematics concepts to students who had already learned them from their private institutions. As discussed earlier, it may be hard to understand students' prior learning without considering education fever in South Korea. Thus, the teachers focus on their students' prior learning of mathematics topics that the teachers are going to teach in the classroom, and they reflect on students' prior learning when developing their lesson plans and classroom teaching. The detailed ways of how the teachers handle students' prior learning will be presented in Chapter 6. The discussion in this section will broaden our understanding of the teachers' knowledge related to South Korean mathematics learners in Chapter 6 as well as the classroom settings that were discussed in Chapter 3.

The National Mathematics Curriculum at the Elementary Level in South Korea

The teachers in this study developed lesson plans and conducted mathematics instruction based on the National Mathematics Curriculum. Thus, it may not be feasible to understand their lesson plans and mathematics instruction without discussing the National Mathematics Curriculum in South Korea.

Along with other subjects, elementary teachers must teach mathematics based on the National Mathematics Curriculum. The teachers in this study also develop their lesson plans, which are one of the major data resources, based on the National Mathematics Curriculum. Thus, it might be a prerequisite to investigate the organization of the National Mathematics Curriculum at the elementary level to understand the teachers' lesson plans as well as their mathematics instruction.

Although there is only one National Mathematics Curriculum in South Korea, the government revises it periodically according to changes in the educational environment and society's needs. This section provides an overview of the National Mathematics Curriculum Revised in 2007 as the teachers in this study taught mathematics according to the seventh revised mathematics curriculum that were announced in February 2007. For practical reasons, in this study, the National Mathematics Curriculum refers to the National Mathematics Curriculum as revised in 2007.

The major emphasis of the National Mathematics Curriculum is to support differentiated that highlights students' mathematical thinking in the classroom as well as students' understanding of mathematical values (Hwang & Han, 2012). Mathematical thinking illustrates mathematical communication ability, mathematical reasoning ability, and problem-solving ability in learning (The Ministry of Education, 2009). In particular, the National Mathematics Curriculum states the objectives of the Elementary Mathematics Education as shown in Table 4.1.

Table 4.1.

The Objectives of the Elementary Mathematics Education (The Ministry of Education, 2009)

<p>Students will learn how to solve mathematics problems that relate to their daily lives and will have positive attitudes toward mathematics by acquiring basic mathematics knowledge and skills and by developing mathematics communication abilities.</p>
--

- | |
|--|
| <ul style="list-style-type: none"> A. Students will learn basic concepts and principles of mathematics by observing and manipulating their daily-lives mathematically. B. Students will learn how to solve daily life problems rationally by developing mathematical thinking and mathematics communication abilities. C. Students will understand the value of mathematics and have positive attitudes toward mathematics with an interest in mathematics. |
|--|

One of the notable aspects of the objectives of the National Mathematics Curriculum at the elementary level in South Korea is to highlight students' affective aspects as well as their mathematical knowledge or mathematical skills such as communication ability. The emphasis was highlighted by including the phrase *Understand the value of mathematics and have a positive attitude toward mathematics* from the objectives (Hwang & Han, 2012). The South Korean elementary teachers develop specified mathematics lesson goals within the range of the objectives of the National Mathematics Curriculum; the teachers should prepare mathematics lessons to foster students' daily mathematics problems-solving abilities, mathematics thinking, or positive attitudes toward mathematics. The statements of the objectives from the teachers' lesson plans in this study are in accordance with the general objectives of the National Mathematics Curriculum at the elementary level as shown in Table 4.2 and Table 4.3.

Table 4.2.

The Objectives of the Chapter from Mrs. Choi's Lesson Plan for Grade 6

Domains	Objectives
Knowledge and understanding	<ol style="list-style-type: none"> (1) Students will understand the basic concept of 1cm^2. (2) Students will understand the basic concept of 1m^2. (3) Students will understand the relationship between 1cm^2 and 1m^2. (4) Students will discover how to calculate the area of rectangles, parallelograms, and triangles.
Skills	<ol style="list-style-type: none"> (1) Students will calculate the perimeter of a rectangle. (2) Students will calculate the area of a rectangle by using an area of a square as a standards unit. (3) Students will calculate the area of a rectangle and a square by using standard units such as 1cm^2 and 1m^2. (4) Students will calculate areas of diverse two-dimensional figures by using an area of a rectangle. (5) Students will calculate an area of a parallelogram by using an area of a rectangle. (6) Students will calculate the area of a triangle by using an area of a rectangle. (7) Students will find the length of the base and the height of a triangle by using its area. (8) Students will calculate a perimeter and area of diverse two-dimensional figures.
Attitude	<ol style="list-style-type: none"> (1) Students will have an attitude to find the basic principles of calculating a perimeter and an area of diverse two-dimensional figures voluntarily. (2) Students will have an attitude to engage in the activities energetically by communicating mathematically. (3) Students will have an attitude to apply their mathematical knowledge, which relates what they learned from the lesson to their real-life problems.

Table 4.3.

The Objectives of the Chapter from Mr. Bae's Lesson Plan for Grade 6

Areas	Goals
Knowledge and understanding	<ol style="list-style-type: none"> (1) Students will understand the basic concept of circumference. (2) Students will understand the basic concept of pi (π) and discover that pi (π) is close to 3.14. (3) Students will discover how to calculate an area of a circle.
Skills	<ol style="list-style-type: none"> (1) Students will calculate a circumference of a circle by using pi. (2) Students will calculate the area of a circle. (3) Students will calculate circumferences and areas of diverse circles.
Attitude	<ol style="list-style-type: none"> (1) Students will have an attitude to make an effort to discover the basic concept of a circle. (2) Students will have an attitude to try to solve diverse problems that relate to circles in their daily lives. (3) Students will have an attitude to discuss their mathematical thinking and ideas.

The National Mathematics Curriculum also provides the mathematics areas and topics. Although the National Mathematics Curriculum does not clarify the sequence of students' learning regarding the topics, there are no significant differences in students' learning in terms of the sequence and the content, as there is only one type of national mathematics textbook, which is published by the government. Table 4.4 shows the mathematical topics that should be covered in elementary school.

Table 4.4.

The Organization of Mathematics Topics (The Ministry of Education, 2007)

Area \ Grade	1	2	3
Numbers and Operation	<ul style="list-style-type: none"> Numbers up to 100 Addition and subtraction with one-digit numbers Addition and subtraction with two-digit numbers 	<ul style="list-style-type: none"> Numbers up to 1,000 Addition and subtraction with two-digit numbers Addition and subtraction with three digit numbers Multiplication Understanding of fractions 	<ul style="list-style-type: none"> Numbers up to 10,000 Addition and subtraction with four-digit numbers Multiplication Division Fraction Understanding of decimals
Shapes*	<ul style="list-style-type: none"> Three-dimensional figures Two-dimensional figures 	<ul style="list-style-type: none"> The foundation of two-dimensional figures Elements of Three-dimensional figures 	<ul style="list-style-type: none"> Angles and two-dimensional figures Movement of two-dimensional figures Elements of a circle
Measurement	<ul style="list-style-type: none"> Comparison of quantity Read time 	<ul style="list-style-type: none"> Time and hours Length Read measurement 	<ul style="list-style-type: none"> Hours Length Cubage Weight
Probability and Statistics	<ul style="list-style-type: none"> Classification with one standard 	<ul style="list-style-type: none"> Developing a table and a graph 	<ul style="list-style-type: none"> Organization of data, Characteristics of data (bar graph, a graphic chart)
Patterns and Problem Solving	<ul style="list-style-type: none"> Finding patterns from a certain arrangement Developing patterns with own rules Finding patterns in a 100-number chart Equations with □ Carrying out a plan/ 	<ul style="list-style-type: none"> Finding patterns in diverse changes Finding patterns from a certain arrangement of numbers/Arrange numbers with own rules Finding patterns in 	<ul style="list-style-type: none"> Developing patterns with a given/or own rules Drawing a table/Making a guess to solve problems

	Drawing a picture/ Developing equation to solve a problem	a multiplication chart • Finding unknown number • Developing an equation • Finding patterns to solve problem/Solve problems in reverse ways	
Grade	4	5	6
Area			
Numbers and Operation	<ul style="list-style-type: none"> • The numbers that are larger than five-digit numbers • Four fundamental rules of arithmetic with natural numbers • Diverse types of fractions • Addition and subtraction with fractions, which have same numerator • Decimals • Addition and Subtraction with decimals 	<ul style="list-style-type: none"> • Divisors and multiples • Reeducation of fractions • Decimals and Fractions • Addition and subtraction with fractions, which have different numerator • Multiplication and division with fractions • Multiplication and division with decimals 	<ul style="list-style-type: none"> • Division with fractions • Division with decimals • Mixed calculation with fractions and decimals
Shapes*	<ul style="list-style-type: none"> • Angles and diverse triangles • Understanding of two-dimensional figures 	<ul style="list-style-type: none"> • Understanding of a rectangular parallelepiped and a regular hexahedron • Congruence • Symmetry 	<ul style="list-style-type: none"> • A prism and a pyramid • A cylinder and a cone • Diverse three-dimensional figures
Measurement	<ul style="list-style-type: none"> • Angles • Perimeters of two-dimensional figures • Approximation • The range of numbers 	<ul style="list-style-type: none"> • Areas of two-dimensional figures • Diverse units for weights and areas 	<ul style="list-style-type: none"> • The ratio of the circumference and area of a circle • Area and volume of three-dimensional shapes
Probability and Statistics	<ul style="list-style-type: none"> • A line graph • Drawing a graph with purpose 	<ul style="list-style-type: none"> • Stem-and-Leaf plots, Graphic graph • Average 	<ul style="list-style-type: none"> • Ratio graphs • Number of cases, probability
Patterns and Solving Problems	<ul style="list-style-type: none"> • Presenting and explaining diverse patterns with numbers • Guessing patterns and explaining 	<ul style="list-style-type: none"> • Ratio • Solving one problem with diverse processes • Finding information with given 	<ul style="list-style-type: none"> • Equation • Proportional expressions • Proportional distribution • Direct/Inverse

	about it through speaking or writing <ul style="list-style-type: none"> • Making patterns • Patterns and correspondence • Simplify, logical guessing for solving problems • Explaining the solving process 	problems <ul style="list-style-type: none"> • Checking solving process 	proportion <ul style="list-style-type: none"> • Comparing solving process • Developing new problems by changing some of data from the given problems • Checking solving process
--	--	---	--

* Note. South Korea's National Mathematics Curriculum refer to geometry as "shapes" at the elementary level because the focus is understanding various shapes than on investigating the relationships among the properties of shapes (The Ministry of Education, 2007).

As discussed in the previous section, the government develops the national mathematics textbook for elementary students and the national teacher guidebook for teachers. The national teacher guidebook includes objectives for each chapter, steps for the lessons, and detailed explanations on the purposes and mathematical background for each activity the textbook provides. Appendix D, which is a translated version of one chapter from the national teacher guidebook for sixth grade, shows the organizations of the national teacher guidebook.

The teachers who have at least 5 years of teaching experiences in this study reported that they are familiar with the sequences of mathematics topics that are presented from the National Mathematics Curriculum, as they have teaching experience with diverse grades. The findings from the analysis suggested that the teachers' knowledge regarding the sequence of mathematics topics is one of the major categories of knowledge for teaching mathematics. The teachers' knowledge about the National Mathematics Curriculum will be discussed in Chapters 5, 6, and 8 with examples of lesson plans, which also include the results of the analysis of the data from the observations of the teachers' mathematics instruction.

Summary

In this section, I have presented a brief overview of the educational context of South Korea. The intent was to provide insight into the educational context of South Korean elementary classrooms, as it may not be feasible to analyze South Korean teachers' intentions in their mathematics instruction without an understanding of it. In particular, the information presented in this chapter demonstrated some aspects of the larger educational context affecting the methodology and analysis process of the study. Based on the educational context of regulating elementary teachers' quality, I assumed that each teacher's knowledge would not be significantly different from each other based on the districts in which the teachers work. In addition, both the regulations placed on the National Curriculum from the government and detailed information regarding the National Mathematics Curriculum are expected to provide a basis for understanding South Korean elementary teachers' knowledge on the National Mathematics Curriculum. This will be discussed in Chapter 5; the teachers in this study placed an emphasis on the National Mathematics Curriculum's objectives and organization when they developed lesson plans. South Korean elementary students' prior learning of mathematics topics before they learn it in their classrooms also will help broaden our understanding of the teachers' survey results on students' mathematics backgrounds, which will be presented in Chapter 6.

The next four chapters present the findings of the study; each chapter will demonstrate one or more categories of South Korean elementary teachers' knowledge for teaching mathematics. Chapter 5 focuses on the teachers' knowledge related to the National Mathematics Curriculum and their practical use of it in their mathematics

instruction. As noted in the framework from Chapter 1, the process of mathematics instruction includes three stages: developing lesson plans, classroom teaching, and assessing students' work. Chapter 6 includes the findings from data analysis regarding the teachers' knowledge about their students as mathematics learners. South Korean elementary teachers' knowledge regarding mathematics content will be discussed in Chapter 7. Chapter 8 demonstrates Mathematics Pedagogical Content Knowledge as one of the major categories of knowledge for teaching mathematics. Chapter 8 also provides interpretive explanations regarding the relationship among categories of knowledge for teaching mathematics with the description of Mathematics Pedagogical Procedure Knowledge. An interpretive analysis is provided at the end of each chapter to emphasize the findings of the study by addressing the research questions.

CHAPTER 5

Knowledge for Teaching Mathematics Category I: Mathematics Curriculum Knowledge (MCK)

This investigation seeks to uncover some of the key categories of South Korean elementary teachers' knowledge for teaching mathematics. Chapters 5 through 8 present major findings from the analysis of 11 South Korean elementary teachers' teaching practices and interviews. An in-depth analysis of the data collected provides a holistic portrait of the South Korean elementary teachers' knowledge for teaching mathematics, addressing the research question defined in Chapter 1. Based on the careful analysis of the data, this chapter offers emergent themes found across the cases rather than focusing on specific aspects of each case. Therefore, Chapters 5 through 8 are primarily interpretive rather than descriptive.

From the analysis of data, five major themes emerged: Mathematics Curriculum Knowledge, Mathematics Learner Knowledge, Fundamental Mathematics Conceptual knowledge, Mathematical Pedagogical Content Knowledge, and Mathematics Pedagogical Procedural Knowledge. This chapter begins with describing the category, *Mathematics Curriculum Knowledge*, of South Korean elementary teachers' knowledge for teaching with particular examples drawn from the research data.

Although the categories of South Korean elementary teachers' knowledge for teaching mathematics were generated from multiple cases, each section illustrates one or two represented cases for the sake of clarification. Stake (2006) noted that the researcher may pick and present the most typical cases in multiple case study analysis to enhance readers' understanding. In each section, the data will be presented based on the instruction processes that were defined from the conceptual framework.

Mathematics Curriculum Knowledge

Whereas Shulman (1986) and Ball et al. (2008) have laid the groundwork for understanding curriculum knowledge, there are not many discussions on teachers' curriculum knowledge. As noted in Chapter 2, Shulman (1987) defined curricular knowledge as “the full range of programs designed for the teaching of particular subjects and topics at a given level, the variety of instructional materials available in relation to those program, and the set of characteristics that serve as both the indications and contraindications for the use of particular curriculum or program materials in particular circumstances” (p. 10). Furthermore, Shulman's definition distinguished curriculum knowledge from both content knowledge and Pedagogical Content Knowledge (PCK).

Although Shulman (1987) distinguished curricular knowledge from PCK, Ball, et al., (2008) argued that curriculum knowledge embedded in Subject Matter Knowledge and PCK are different. The former, named horizon content knowledge, indicates that there is an understanding of the relationship among mathematical topics over the span of the mathematics curriculum (Ball, 1993). The latter, knowledge of content and curriculum, is similar to Shulman's definition of curricular knowledge (Ball, et al., 2008). However, Ball, et al. (2008) suggested that there needs to be more investigations on teachers' use of curriculum knowledge in their classroom teaching. Shulman (1987) and Ball, et al. (2008) used antithetical vocabularies, however, for the purpose of this study, curriculum knowledge is defined as an understanding of the relationship among topics in the mathematics curriculum. An additional element of this definition is that the mathematics curriculum is a way of organizing mathematics topics to support students' learning (Donovan & Bransford, 2005).

From the data analysis, this study found that the teachers have rich knowledge of the mathematics curriculum, and this knowledge affects their teaching in diverse ways. Because there are diverse definitions of curriculum knowledge, this research refers to teachers' curriculum knowledge for teaching mathematics as Mathematics Curriculum Knowledge (MCK). MCK indicates teachers' understanding of the sequence among mathematical concepts that exist both inter-grade and intra-grade. As noted in the Conceptual Framework presented in Chapter 1, this study assumed that internal representations might be connected to one another in useful ways. Regarding MCK, the internal representation indicates the mathematics topics provided by the National Mathematics Curriculum. The knowledge related to MCK is divided into two subcategories: vertical and horizontal sequence of learning in elementary mathematics curriculum. Vertical mathematics curriculum knowledge (VMCK) demonstrates that the general order of what students learn across each grade (e.g., mathematics topics across grades first to third). Horizontal mathematics curriculum knowledge (HMCK) is composed of the mathematics curriculum in one grade level (e.g., mathematics topics for first grade).

However, this does not mean that MCK simply indicates teachers' memorization of the order of mathematics topics, which are introduced according to the National Mathematics Curriculum. Recent studies of teachers' curriculum use show that teachers apply curriculum based on their interpretations rather than simply deliver mathematics content according to the curriculum (Lloyd, 2012). Therefore, MCK should be defined as an instructional process. The range of the teaching process that is affected by elementary

teachers' MCK consists of developing the instructional process, classroom teaching, and assessing students' work as defined by the conceptual framework in Chapter 1.

Mathematics Curriculum Knowledge in Mathematics Instruction

Presented in this section are findings that emerged from data analysis, which suggest that for the participants of this study, instruction involved three stages: the use of MCK when developing an instructional process, the use of MCK when teaching the lesson, and the use of MCK in assessing students' works.

Using MCK When Developing an Instructional Process

Analysis of the lesson plans revealed that the teachers used MCK when they prepared lessons. From the lesson plans, the teachers clarified the relationship among mathematical concepts and extracted meaningful implications from it. Specifically, in their lesson plans, the teacher used VMCK when presenting the relationship among mathematics concepts across grades, referring to it as *the flow of learning* (See Figures 5.1 and 5.2.) This section presents two representative examples of the 11 teachers' lesson plans, indicating their understanding of the relationship among mathematics concepts presented in the National Mathematics Curriculum.

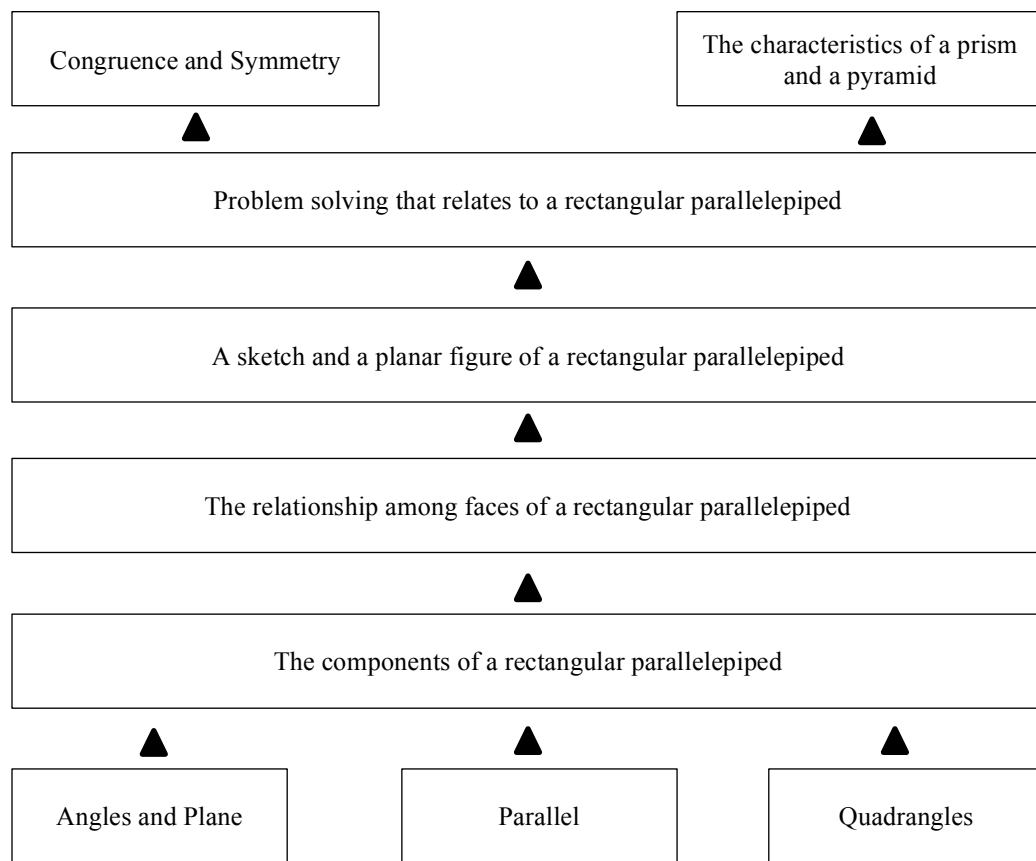

Figure 5.1. The Flow of Learning from Mrs. Kim's Lesson Plan

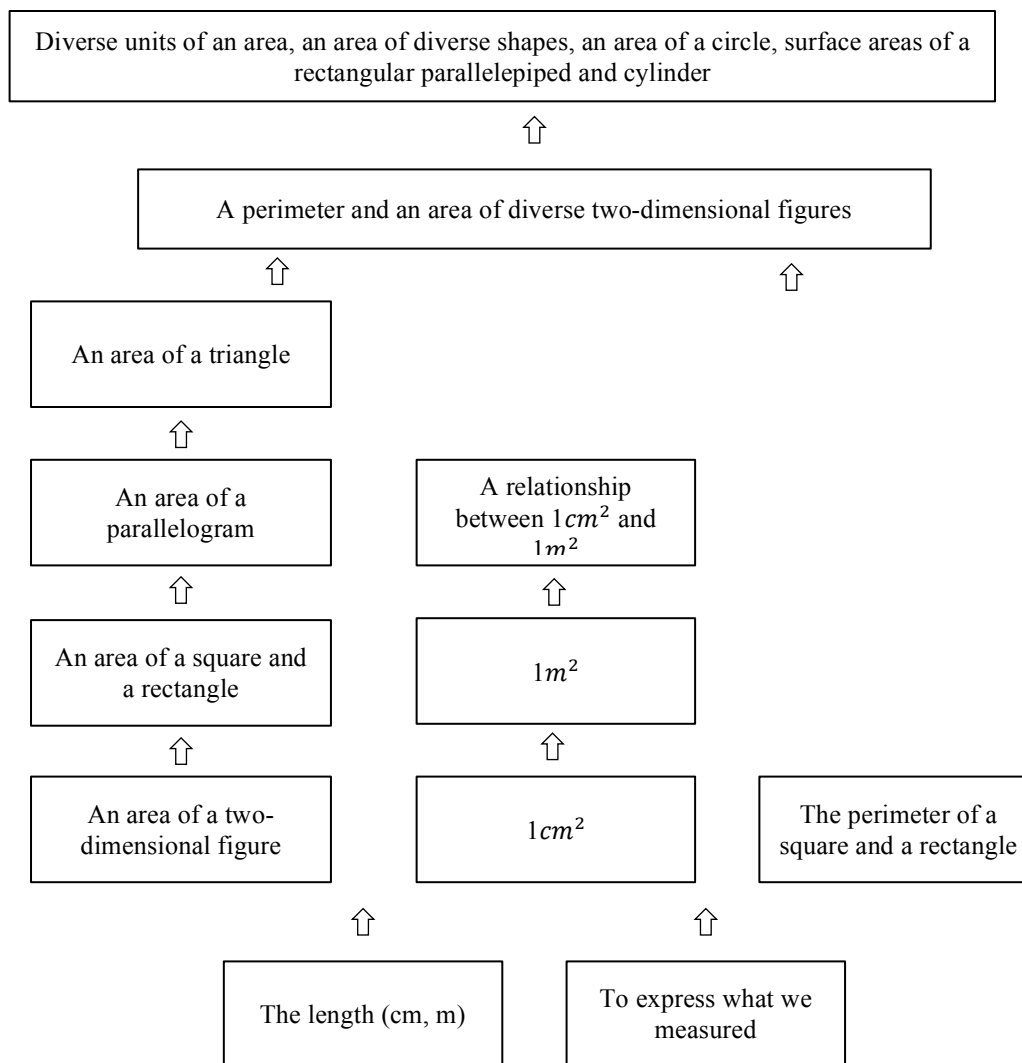

Figure 5.2. The Flow of Learning from Mrs. Choi's Lesson Plan

Not only did the teachers indicate the relationship among mathematics concepts, but also they used this information for analyzing their students' mathematical backgrounds. The teachers developed survey questions based on the mathematics concepts that their students should have learned in their previous grade based on VMCK. Nine teachers developed survey questions and made notes of the results in their lesson plans. Tables 5.1 and 5.2 show the results of the survey developed by two of the teachers to offer a sense of students' mathematical backgrounds. Mrs. Kim's survey focused on

mathematical understanding, whereas the focus of Mrs. Choi's survey was on mathematical skills. The results illustrate that the majority of students in Mrs. Kim's students did not have a basic understanding of the content to be covered in her lesson, while the majority of Mrs. Choi's students were proficient in the skill areas to be covered in her lesson.

Table 5.1.

Mrs. Kim's Survey on Students' Mathematical Understanding

Results	Number of students	Percent (%)
Students do not understand the basic concept of parallel lines or cannot draw well.	8	19.1%
Students do understand the basic concept of parallel lines or can draw.	27	64.3%
Students do understand the basic concept of parallel lines and can draw well.	7	16.6%

Note: Mrs. Kim's students are in fifth grade.

Table 5.2.

Mrs. Choi's Survey on Students' Mathematical Skills

The questions for investigation	Results	N (28)	%	Analysis
Can students measure length by using standard units and read gradation?	Top	25	89	In general, students can measure length by using standard units.
	Middle	3	11	
	Bottom	0	0	

Note: Mrs. Choi's students are in fourth grade.

The teachers applied the survey results in planning their lessons and documented what they were going to do during instruction. When the teachers were interviewed, they provided explanations of how they used the information from the surveys to construct activities that would help their students develop their understanding of the content or improve their mathematical skills, explaining:

Mrs. Kim: Students should have learned the basic concept of parallel lines in order to participate in today's lesson. Most students in the class understand the basic

concept of parallel lines. However, some students still struggled with drawing parallel lines. Therefore, I need to provide some activities that relate to drawing parallel lines during the lesson, although the students have already learned it. This activity should include detailed instruction about drawing parallel lines for students who cannot draw parallel lines. At the same time, this activity should not bore students who know how to draw parallel lines and already understand the concept of them.

Mrs. Choi: Students should have learned the basic concept of standard units to calculate the area of a parallelogram. From my survey, I found that most of my students had learned about the concept of standard-units and that they could use standard units when they measure length. Therefore, I thought I didn't need to explain the basic concept of standard units or how to use them. I just supported my students as they learned to count the standard units by themselves.

Based on their analysis of the survey results, the teachers developed a detailed plan about how to help students understand mathematics concepts. An excerpt of Mrs. Kim's plan for the lesson is shown in Table 5.3.

Table 5.3.

Mrs. Kim's Lesson Plan

Major Topic of the Lesson	Sub-topic of the Lesson	Teaching-Learning Activity		Time (Minutes)	Materials (-) Notes (*)
		Teacher	Students		
∴ To understand the basic concept ∴	∴ Activity 1 ∴	∴ -A teacher presents the PowerPoint Slides (PPT), which shows a rectangular parallelepiped with signs at each vertex. • What are the edges that run parallel to the edge AB ($\sqcap \sqcup$)? • How should we draw these parallel edges? • Let's draw them together. -A teacher repeats the same questions to help students find and draw the other edges, which run parallel to each other. ∴	∴ -Students compare their own work and PPT. • They are the edge BF ($\sqcup \sqcap$), the edge CG ($\sqcap \sqcup$), and the edge DH ($\sqcup \sqcap$). We should draw them as parallel. ∴	∴ 5' ∴	∴ * PPT ∴

Mrs. Kim reported that she had developed the lesson plan based on what she found from her survey. Mrs. Kim discovered that students still struggled with drawing parallel lines even though they had learned how to draw them in their previous grade. Therefore, Mrs. Kim provided the activity that might help her students find diverse parallel lines and then draw them. During the third interview, Mrs. Kim clarified her intention, stating:

From the survey, I found that some of my students couldn't draw parallel lines, even though they had learned about them in their previous grade. However, I couldn't teach how to draw them because the other students already knew how to draw them. If I just focus on the students who can't draw, the other students may feel the lesson is boring because they already knew the material. Therefore, instead of teaching them how to draw parallel lines directly, I specified the ways of finding and drawing parallel lines step by step. I could make my students find and draw all the parallel lines at once. However, I intentionally took them through the process systematically. I supported my students to find one pair of parallel lines and draw them. By supporting my students to find and draw slowly and consciously, I can help the students who did not draw parallel lines well to participate in the whole class activity.

Mrs. Choi reported that she developed the learning activity that is presented in Table 5.4 based on the results of her survey investigation of students' mathematical background. Mrs. Choi found that her fourth-grade students knew how to use standard units to calculate the area of a parallelogram. Therefore, Mrs. Choi's activity that she had developed for the lesson was designed to support students' learning. The activity engaged students in work that required them to find diverse ways of counting standard units of a parallelogram. During the third interview, Mrs. Choi explained her intention, stating:

My students knew the basic concept of standard units and how to use the units to measure length and areas. Therefore, I didn't need to explain it during the lesson. Instead, I wanted my students to focus on finding diverse ways of counting standard units in a parallelogram.

Analysis of the lesson plans suggests that these two teachers as well as the seven other teachers applied the VMCK to their lesson plans. Because the teachers are required to follow the National Mathematics Curriculum, the sequence and presentation of their lessons were similar. They considered the major- and subtopics of the lesson, teaching-learning activities that promoted learning and understanding of the topic, an estimate of the time it would take to cover various components of the lesson, and the materials that were needed to engage students in the learning activities. Although the teachers applied a similar framework, what was different about their lesson plans were the learning activities they designed to help students learn the material. During the interviews, these teachers stated without any major prompting that they planned activities by considering students' mathematics backgrounds or experiences. As stated in Chapter 3, many of the students, except for those in first grade, had attended private institutions or had had tutors

to assist them with mathematics outside of the school day. This fact created much anxiety for the teachers. They could have selected to ignore the fact that their students were receiving help outside of their classes; however, they chose not to ignore it and to be proactive by surveying students about their past mathematics experiences. Thus, the surveys provided information that they were able to use when planning their lessons.

In addition, the teachers used HMCK when they developed the instructional procedures. In the lesson plan, 10 teachers organized the sequence of lessons from the textbook chapter and explicated the relationship among the lessons. This process is referred to as *deployment plan from the textbook chapter* as shown in Tables 5.5 and 5.6. Based on their HMCK, the teachers specified the range of topics in each lesson. When planning their lessons, the teachers examined each topic presented in the textbook chapter, making note of the relationships among the various subjects to write the content objectives and activities to be achieved by the students.

Table 5.5.

Mrs. Kim's Deployment Plan for the Textbook Chapter

Sequence (Textbook)	Subject	Content Objective and Activity
⋮	⋮	⋮
Lesson 3 (p. 56–p. 58)	The relationship among faces in a rectangular parallelepiped	<ul style="list-style-type: none"> • Students will find faces, which are parallel to each other in a rectangular parallelepiped. • Students will find faces, which are perpendicular to each other in a rectangular parallelepiped.
Lesson 4 (p. 59–p. 60) Today's Lesson	The sketch of a rectangular parallelepiped	<ul style="list-style-type: none"> • Students will understand why we need to sketch a rectangular parallelepiped. • Students will learn how to draw a sketch of a rectangular parallelepiped.
⋮	⋮	⋮

Table 5.6.

Mrs. Choi's Deployment Plan for the Textbook Chapter

Sequence	Subject	Content Objective and Activity	Textbook
⋮	⋮	⋮	⋮
Lesson 5	The ways of calculating areas of two-dimensional shapes by using the area of a rectangle	To calculate diverse shapes of two-dimensional figures by using the area of a rectangle	p. 95–96
Lesson 6 (Today's lesson)	The way of calculating an area of a parallelogram	To understand and calculate areas of a rectangle and a square	p. 97–99
Lessons 7–8	The way of calculating an area of a triangle	To understand and to calculate areas of a rectangle and a triangle	p. 100–104
⋮	⋮	⋮	⋮

The teachers also developed their teaching strategies and used them to predict students' reactions during the lesson. During the third interview, the teachers clarified their intentions. The following excerpt from the transcript of the third interview relates to the teacher's use of HMCK for teaching a lesson.

Interviewer: How did you motivate your students?

Mrs. Kim: At the beginning of the lesson, I intentionally deceived my students. Can you remember that a prism looked like a cube? I purposely presented a prism because I wanted students to notice the need for a sketch of three-dimensional shapes.

Interviewer: Then you already knew your students' answers when you prepared the lesson? This was a chance for your students to give the right answers. Did you have a Plan B?

Mrs. Kim: I did not have a Plan B. I knew that students would provide wrong answers [because] I had shown them a face of a rectangular parallelepiped with similar

materials during the previous lesson. My students just believed it was the same face, which they had observed in their previous lesson ... I usually plan whole lessons together before I start a new chapter. I check the connection among topics in a chapter or with other chapters, and I prioritize the mathematics concept or strategies that I am going to teach. I decided how much time to spend on each subject. Also, I checked the materials that I needed for each subject [because] a chapter consists of subjects that are related to each other. So, I think that I should make a coherent connection among lessons at least in the chapter. Sometimes, there is a certain relationship among chapters. For example, students learn from 1 to 9 in one chapter first and from 10 to 99 in the next chapter in first grade. I believe that teachers help students find these connections among mathematical concepts.

Emerging from Mrs. Kim's statement is the importance of examining relationships across topics or subject. This not only helped her have a sense of the scope of the content, but it also helped her consider how she might work with her students to assist them in making mathematical connections. Furthermore, by examining all of the topics presented in a chapter of the textbook, she was able to construct content objectives and to consider what activities might be appropriate for teaching that topic. She also looked ahead at the content presented in the next chapter to view how that content related to the current content she was about to teach.

When Mrs. Choi discussed how she had used the textbook chapter, she elaborated on how she looked across various lessons to develop her content objectives and activities, noting that an important part of her planning included thinking about what materials

might be needed to help students develop their understanding of the content. This is evidenced when she was asked during the third interview about how she motivated her students. Mrs. Choi explained:

I used tangrams to motivate my students. My students like to play with tangrams. However, the most important reason I used tangrams during the lesson is that students may change a parallelogram into a rectangle easily. My students had learned how to calculate the area of a rectangle in a previous lesson. I wanted my students to notice that it might be easy to calculate the area of parallelogram if it is changed into the shape of a rectangle.

Shulman (1987) and Ball et al. (2008) clarified that curriculum knowledge is presented by the full range of programs designed for teaching particular topics based on understanding of instructional materials. However, the teachers participating in this study focused on the relationship among mathematics concepts based on the National Mathematics Curriculum and tried to find meaningful instructional implications from it rather than just concentrating on the use of instructional materials in order to teach a specific mathematical topic. This may show that there is a need to focus on the curriculum itself regardless of diverse instructional materials in order to reveal the effectiveness of HMCK.

In addition, while Ball, et al. (2008) distinguished horizon content knowledge from pedagogical content knowledge and categorized it in the range of Subject Matter Knowledge, VMCK seems to relate to knowledge of content and students and knowledge of content and teaching, which are in the range of pedagogical content knowledge in their knowledge domain. These teachers used their mathematics curriculum knowledge to

analyze or understand their students' mathematical background and to use it in their classroom teaching. Therefore, there needs to be more discussion about the role of MCK in teachers' instruction and its location in the domain of teachers' mathematical knowledge.

Using MCK When Teaching the Lesson in a Classroom

All of the teachers participating in this study started the lesson by reviewing the previous lesson and ended the lesson by forecasting the next lesson according to their lesson plans. The teachers tried to make connections among the topics of one chapter based on their HMCK. In addition, the teachers followed their lesson plans. Nine teachers used the information from the surveys they had given to students, which were developed based on their MCK. For example, during the third interview, Mrs. Kim and Mrs. Choi clarified their intention:

Mrs. Kim: Based on the survey, I developed a method for drawing a sketch of rectangular parallelepipeds for the students who already knew the basic concept to use and at the same time I used this methods to lead the students who did not have a good understanding of the basic concept. I asked my students how to find and draw parallel edges, rather than just explaining how to do it.

Mrs. Choi: I focused on what students should learn during the lesson rather than reviewing what they had learned in a previous lesson. Most of my students understood mathematics concepts from their previous mathematics lessons. By making use of MCK during the lesson, the teachers were able to engage all the students during the lesson, considering those who were familiar with the concept and those who were not. In addition, the teachers' MCK affected their use of vocabularies in

their classroom teaching. The teachers were careful about using manipulatives and mathematical terms in their lessons. The following excerpt from the transcript of the third interview relates to the teacher's use of vocabulary for teaching the lesson. When asked about their use of mathematical terms, seven of the eleven teachers responded in similar ways as Mrs. Kim and Mrs. Jeong had.

Mrs. Kim: I'm trying to use them carefully based on students' [current] grade level.

There are certain stages in which to introduce mathematical terms to students according to the mathematics curriculum. [For example], during the lesson that was observed, I did not use the term 'prism,' although I showed a prism to my students. I did not use the term on purpose, because my students are going to learn about prism in a higher grade. I focused on the grade level mathematical terms introduce based on the National Mathematics Curriculum. If I use a mathematical word that is going to be introduced in the future, it may lead students' to develop misconceptions because they had not learned enough associated mathematics concepts to understand those terms.

Mrs. Jeong: Today's class was the first lesson of the chapter, which is about diverse quadrangles. Although I showed diverse shapes of quadrangles such as a rectangle or a rhombus; I didn't name them during the lesson. My students are going to learn the names of each quadrangle in the following lessons.

Therefore, I do not use the names of quadrangles on purpose.

In this study, the teachers' MCK affected the way they organized activities and the use of mathematical vocabularies during the lesson; the teachers tried to make connections among lessons based on their HMCK. Furthermore, the teachers were very careful about

their use of mathematical terms, as it might encourage students' development of mathematical misconceptions. This indicates that MCK may affect teaching directly, which suggests that the basic assumption of categories should be reexamined or that the relationship between Subject Matter Knowledge and Pedagogical Content Knowledge should be redefined.

Using MCK When Assessing Students' Work

The teachers used MCK when they analyze students' mathematical background and assess their work. According to their lesson plans, 10 teachers conducted a diagnostic assessment on their students based on what they had learned in their previous grade. In addition, the teachers applied this knowledge when they assessed a student's work. (See Appendix C.)

The following episodes from the analysis of the transcript from the second interview relates to knowledge of mathematics and ideas about teaching and learning mathematics. All of the teachers were asked to examine work completed by a child in second grade involving subtraction with regrouping.

Mrs. Yang: If the child really doesn't know the basic concept, she has to learn place value, subtraction, and regrouping. She had to learn the basic concept of zero when she was in the first grade. So, it is almost impossible for her to learn zero in her second grade. I think I have to find extra time to help her.

Interviewer: Do you check the National Mathematics Curriculum every time?

Mrs. Yang: No, I don't. I have taught almost every grade during the last 10 years.

Therefore, I just remember it. Although I can't tell you about the curriculum exactly, I know the general sequence of the National Mathematics curriculum.

Having a strong knowledge base of the sequence of curriculum from across grade levels assists teachers in making decisions about how to help students who may not have mastered certain content targeted for a particular grade. As indicated in Mrs. Yang's comments, her experience of having taught all of the elementary grades over the past 10 years provided her with a breadth of knowledge about the National Mathematics Curriculum; thus, she not only used that knowledge to plan instruction but also used it to make sense of students' mathematical learning gaps of students. Mr. Bae offered a similar explanation as illustrated in the statement below.

Interviewer: Suppose you are teaching first grade and you noticed that one of your students has labeled a picture of a square with an R for rectangle. What would you do or say?

Mr. Bae: Well, I wouldn't do anything.

Interviewer: Please explain.

Mr. Bae: First of all, it is not wrong. I mean in a mathematical way. As you know, we don't use the words, "square" or "rectangle" in the first grade. Although we teach a quadrangle with the name of "nemo"¹, you know, it refers to quadrangle. And ...a rectangle includes a square. Therefore, this student was not wrong at all. And ... students learn the relation among quadrangles by fourth grade, right? I'm not sure, but I think it was the fourth grade based on the national curriculum. Anyway, students are going to learn about it later, so I think I don't need to explain it. Also, I don't need to be worried about the exact names of rectangles at this moment.

¹In South Korea, *nemo* is a term used predominately in kindergarten or the early grades in elementary schools as a reference to a shape that looks like quadrangle.

Ten of the eleven teachers provided similar answers to that of Mrs. Yang, and eight of eleven teachers made similar judgments as Mr. Bae had. The teachers' use of their MCK in assessing students' work may show that MCK is integrated with knowledge that relates to understanding students' mathematical background. This finding provides some clues about the reason elementary teachers' mathematical knowledge may have little effect on improving students' mathematics achievement scores for those who had received low scores on previous achievement tests (e.g., Hill, 2008; Hill et al., 2005; Tanase, 2011). If a teacher only focuses on the transformation of mathematical ideas for the current grade based on pedagogical content knowledge and does not pay attention to students' previous mathematical experiences, it might be difficult to expect students to develop an understanding of new mathematics concepts they had not learned in their previous grade.

A further insight is that these teachers acquired MCK overtime because they taught mathematics at various grade levels. Examining how teachers acquire MCK and their subsequent use of it for planning, teaching, and assessing may help us understand the relationship between teachers' knowledge for teaching mathematics and their experiences. Although there are studies that suggest teachers who have experience with a wider range of grades in elementary schools have better knowledge for teaching mathematics than do those who have taught only one or two elementary grades (e.g., Ng, 2011; Chinnappan & Lawson, 2005), it is still unclear how teaching experience contributes to teachers' knowledge for teaching. The findings from this study demonstrate that teachers' teaching experience at diverse grade levels helps them understand the mathematics topics covered in the curriculum.

Interpretive Summary

This chapter presented the findings that emerged from data analysis of interviews and lesson plans. An important element of data analysis was consideration of the conceptual framework discussed in Chapter 1. In attempting to analyze MCK in an actual instructional process with diverse types of data, this study found that MCK is one of the essential categories of an elementary teacher's knowledge for teaching mathematics and that MCK is integrated into elementary teachers' entire instructional process, which includes planning the lesson, teaching the lesson, and assessing student learning of the content presented during the lesson.

To make sense of how the teachers accomplished these instructional practices, MCK is divided into two subcategories, which are referred to as the VMCK and HMCK. When developing lesson plans, both HMCK and VMCK were applied when presenting the relationship among mathematics concepts or topics across grades, which they called *the flow of learning*. Specifically, the teachers identified the range of topics for each lesson using HMCK. A finding that emerged from the data is that the teachers' examination of relationships among mathematics concepts and topics served as catalyst for investigating their students' mathematical background and experiences. This helped them make sense of the scope of the content and to consider how they might work with their students to assist them in making mathematical connections. Additionally, the teachers wrote their lesson plans based on the sequence of topics or concepts outlined in their mathematics textbooks, and they were able to write content objectives, including the development of applicable activities for teaching the concept.

Another finding that emerged from analysis of data is that the majority of the teachers participating in this study discussed how they had applied the National Mathematics Curriculum to their teaching, specifically to lesson planning. This was done in several ways. First, the National Mathematics Curriculum was used to sequence the various topics or concepts to be covered during their lessons. This helped them examine the relationship among various topics and concepts. In this case, it is important that elementary teachers know the relationship among mathematical concepts in order to support their students because there are direct parallels between the ways teachers connect their mathematical knowledge and the instruction they implement in their classrooms as a result (Carpenter, Fennema, Peterson, Chiang & Loef, 1989; Fennema, Carpenter & Peterson, 1989; Peterson, Fennema & Carpenter, 1991).

Second, participants' knowledge of the National Mathematics Curriculum regarding the required concepts and topics that must be covered at each grade level assisted them in identifying mathematical learning gaps of students who may not have mastered certain concepts. As shown in this study, VMCK and HMCK provide some criteria for understating students' mathematical background. A number of studies suggested that teachers should understand students' mathematical experiences (Fennema & Romberg, 1999; Brophy, 1997; Carpenter, Franke, Jacobs & Fennema, 1998). Although the information about students' mathematical background from the analysis based on MCK cannot represent the whole picture, it does help teachers understand more about students' mathematical experiences. The more teachers know about their students' mathematical backgrounds, the more opportunities teachers have to provide effective instruction to their students.

Third, the teachers were familiar with the National Mathematics Curriculum across grade levels because most had taught mathematics in many of the elementary grades, which assisted them in making decisions about how to help students who may not have mastered targeted concepts for a particular grade level. In addition, the teachers' MCK affected their use of mathematical vocabulary in their classroom teaching; the teachers were careful about using manipulatives and mathematical terms in their lessons. Previous studies have focused heavily on PCK (Izsák, 2008; Rowland, Huckstep & Thwaites, 2005; Santibañez, 2005). However, as shown in this study, teachers' MCK also relates to elementary teachers' teaching. In particular, MCK seems to relate to knowledge of understanding students' mathematical background and use of mathematical vocabulary in the classroom teaching of mathematics.

This chapter presented findings about South Korean elementary teachers' Mathematics Curriculum Knowledge, illustrating how curriculum knowledge may affect planning and teaching. Chapter 6 presents findings about the second category of elementary teachers' knowledge for teaching mathematics: Mathematics Learner Knowledge.

CHAPTER 6

Knowledge for Teaching Mathematics Category II: Mathematics Learner Knowledge (MLK)

Findings presented in the previous chapter suggest that elementary teachers' Mathematics Curriculum Knowledge is a major category of South Korean elementary teachers' knowledge for teaching mathematics. This chapter focuses on the second category of elementary teachers' knowledge for teaching mathematics: *Mathematics Learner Knowledge*. Mathematics Learner Knowledge is related to teachers' understanding of mathematics learners.

Various researchers point out the significance of teachers' knowledge of their students. For example, Banks (2005) asserted that teachers should be prepared to teach diverse students for effective teaching because students are different from each other in various ways (e.g., interest, cognitive development). Calderhead and Shorrock (1997) highlighted that teachers should understand their students' abilities and interests and how students tend to respond to various learning situations. In addition, Shulman (1987) emphasized the importance of teachers' knowledge about their students, stressing that teachers' knowledge about learners is interconnected with Pedagogical Content Knowledge. Pedagogical Content Knowledge represents teachers' knowledge of how particular subjects and topics are organized and presented to the diverse interests and abilities of learners (Shulman, 1987).

Although there is an agreement that teachers should understand their students' mathematical backgrounds and characteristics, the definition of knowledge of learners for teaching mathematics is still vague; there are many characteristics about students for mathematics teachers to consider. For example, teachers should know their students'

preconceptions about mathematics (Donovan & Bransford, 2005), educational context (Fennema & Franke, 1992), students' emotional development based on their ages (Golbeck & Ginburg, 2004), and the ethnic group to which students belong (NCTM, 2000). Needless to say, the more teachers know about their students, the more students may have chances to receive differentiated mathematics instruction according to their mathematics backgrounds. However, if there are too many things to consider, a teacher may miss key aspects about their students for teaching mathematics.

Therefore, this chapter starts with a discussion about the definition of Mathematics Learner Knowledge and its key subcategories. The discussion in this section provides a basis for understanding the teachers' use of Mathematics Learner knowledge in their mathematics instruction. The section of this chapter is an interpretive summary of the key findings.

Mathematics Learner Knowledge

This study refers to teachers' knowledge of learners for teaching mathematics as Mathematics Learner Knowledge (MLK) to make a clear distinction from elementary teachers' general understanding about their students. In this study, MLK describes teachers' understanding about the characteristics of mathematics learners and how it is used in teachers' mathematics instruction. Although MLK is defined in a general sense for this study, there are key subcategories of MLK: students' mathematical knowledge, students' mathematical skills, and students' mathematical attitude. In this case, *students* represent mathematics learners who are learning mathematics in formal classroom settings according to the National Mathematics Curriculum. *Students' mathematical knowledge* represents their conceptual understanding of mathematics topics (e.g.

understanding the concept of parallel lines), while *mathematical skills* indicates both students' procedural understanding and skills needed to solve mathematics problems (e.g., know how to draw parallel lines with rulers). *Students' mathematical attitude* involves students' preferences for mathematics and how they perceive the value of mathematics (이중권, 2004).

The key subcategories emerged primarily from the analysis of the participants' lesson plans. All of the 11 teachers provided information about their knowledge concerning their students in the *Understanding of Students* section of their lesson plans. The section presents both the teachers' knowledge of their students and the results of an analysis of their students' mathematics background taken from their lesson plans as shown in Table 6.1. The examples presented in this section of the teachers' knowledge about their students represent all of the study's participants.

Table 6.1.
The Investigation on Students' Mathematical Background from Mrs. Choi's Lesson Plan

Categories	The target aspect of students	Results*	N (28)	%	Analysis
Students' Mathematical Knowledge/understanding	Do students know the basic concepts of a parallelogram?	Top	6	21	In general, students understand the basic concepts and features of a parallelogram, as they already have learned about it from their private institutions. However, most of them only memorized the definition of a parallelogram. When they viewed an atypical type of a parallelogram, they did not consider that it to be a parallelogram.
		Middle	21	75	
		Bottom	1	4	
Students' Mathematical Skills	Can students draw diverse shapes of a parallelogram?	Top	19	68	There are students who cannot draw a parallelogram in diverse ways. Therefore, there needs to be an extra exercise for these students that instruct them how to draw a parallelogram in diverse ways based on the mathematical concepts.
		Middle	6	21	
		Bottom	3	11	
	Can students measure length by using standard units and read gradation?	Top	25	89	In general, students can measure length by using standard units.
		Middle	3	11	
		Bottom	0	0	
Students' Mathematical Attitudes	Do students show interest in getting involved in discover-centered mathematics lessons?	Top	24	86	In general, students were involved in discover-centered mathematics lesson and showed interest.
		Middle	4	14	
		Bottom	0	0	

*Note. The terms top, middle, and bottom indicate how the teachers ranked learners according to their mathematics knowledge.

As illustrated in the table, Mrs. Choi demonstrated her knowledge of her students in three categories: knowledge/understanding, skills, and attitude. This was not unique to Mrs. Choi's lesson plan. The other 10 participants also provided information about their knowledge of students in the same three ways. Mr. Choi provided explanations of the

three categories during her third interview, stating:

According to the National Mathematics Curriculum, we have to present the objectives of the lesson in three ways: knowledge and understanding, skill, and attitude (See Chapter 4). Therefore, I have to know my students' current status in these three domains to help them achieve the instructional goals. I know that the more teachers know about their students, the more they have a chance to provide effective mathematics instruction to their students. However, at the same time, teachers cannot know everything. So I decided that I had to at least know about students' backgrounds, which affect their learning the objectives of the lesson.

Interviewer: Please explain more about the differences among the three categories?

Mrs. Choi: For me, knowledge and understanding indicates students' relational understanding. They have to understand the basic concepts of mathematics. Skill means instrumental understanding. Students may draw parallel lines without relational understanding of what they are. Well, students may simply know how to solve the problem or draw figures without knowing what they mean. And the attitude represents students' interest in mathematics topics. Students may just do their work during the lesson because they simply have to. In that case, students may learn about mathematics topics, but at the same time, they may dislike mathematics. I think that this is not what we want from mathematics education.

From the interview, Mrs. Choi clarified how she focused on the three categories of students' characteristics, as this was needed to help her students achieve the lesson's objectives. Also, Mrs. Choi pointed out that she had set up the objectives in the three

categories according to the National Mathematics Curriculum. This implies that the National Mathematics Curriculum provides criteria that assist teachers in discerning information in developing an understanding of their students as mathematics learners. Similar approaches also were found in other cases. For example, Mr. Bae presented his MLK in his lesson plans as shown in Table 6.2.

Table 6.2.

The Investigation on Students' Mathematical Background from Mr. Bae's Lesson Plan

Categories	The target aspect of students	Results*	N (28)	Analysis
Students' Knowledge /understanding	Do students know the properties of a circle?	Top	20	In general, students understand the properties of a circle well. Thus, I may not need to review this during the instruction. However, I need extra time for helping students who do not know the properties well.
		Middle	6	
		Bottom	1	
Students' Mathematical Skills	Can students measure the perimeter of shapes with a ruler?	Top	13	Although the students might do well in calculating the perimeter of diverse shapes, they are not familiar with measuring perimeter with a tape measure. There is a chance that my students only know how to calculate perimeter with a formula, but they might not have basic conceptual understanding of perimeter. Also, there needs to be an exercise about to how to use a tape measure.
		Middle	10	
		Bottom	4	
	Can students calculate perimeters of diverse shapes by using a formula?	Top	21	
		Middle	4	
		Bottom	2	
Students' Mathematical Attitude	Can students find mathematics problems in their daily lives?	Top	20	Most of my students can find mathematics problems in their daily lives. Thus, I may use students' experience that relates to today's lesson. Also, I need to plan how to support the students who may not show interest in finding mathematics problems in their daily lives.
		Middle	4	
		Bottom	3	

*Note. The terms top, middle, and bottom indicate how the teachers ranked learners according to their mathematics knowledge.

From the Table 6.2, Mr. Bae also may note his knowledge about his students in the three categories. The transcripts from the third interview with Mr. Bae illustrate that he considered the objectives of the National Mathematics Curriculum when he classified the three categories, explaining:

I focused on these three categories according to the objects of the National Mathematics Curriculum. The objects of the National Mathematics Curriculum include these three aspects of students. According to the National Mathematics Curriculum, teachers should improve their students' mathematical knowledge, skills, and attitude such as valuing mathematics. As such, I stated the objectives of the lesson in three ways as you saw from my lesson plan (See Table 6. 3).

Table 6.3.

The Objectives of the Lesson from Mr. Bae's Lesson Plan

Domains	Objectives
Knowledge /understanding	<ul style="list-style-type: none"> • Students will understand the meaning of circumference. • Students will understand the meaning of pi (π) and know that pi (π) is close to 3.14. • Students will understand how to calculate the area of a circle.
Skills	<ul style="list-style-type: none"> • Students will find the circumference of a circle by calculating with pi (π). • Students will find an area of a circle by calculating with pi (π).
Attitude	<ul style="list-style-type: none"> • Students will make an effort to discover diverse concepts that may relate to a circle. • Students will show a positive attitude toward solving diverse mathematics problems that relate to circles in their daily lives. • Students will show a positive attitude when actively participating in the classroom discussion by presenting their mathematical thinking and ideas.

Mr. Bae continued with his explanation in which he elaborated on how important it is for him to support his students. The goal is for the students to meet the lesson objectives. He stated:

Thus, I need to know about at least these three categories about my students in order to support them in accomplishing the lesson's goals. If I do not know about my students' current status, how can I help them achieve the lesson's goal? For example, my students should know the characteristics of a circle in order to understand the meaning of circumference, which is one of the objectives of today's lesson. Thus, I need to know whether my students already know the properties well or not. If my students already know them well, I may not need to review the properties of a circle in the classroom, as it might be a waste of time. On the other hand, if my students are confused about them or might not know them well, I need to review the properties to try to make a connection between the properties and today's topic even though the students had learned it in their previous grade. So, I make note of what I know but also of what I should know in order to support my students in achieving the lesson goals of my lesson plan.

Interviewer: Among diverse aspects of students' knowledge, is there any reason for you to focus on properties of a circle as a knowledge category?

Mr. Bae: Well ... yes. As I mentioned previously, I need to help my students achieve the lesson goal. The questions for knowledge and skills categories from the table addressed the key knowledge and skills that students should have to learn for today's mathematics topic. If they do not know or do not have those skills, it might be hard for students to follow my lesson. Thus, I need to check first, and if

my students might not have this knowledge or the skills, then, I need to plan extra activities to improve their knowledge and skills to help them be prepared for learning a new topic.

Interviewer: How do you find the key knowledge or skills?

Mr. Bae: Well, first of all, I checked the objectives of the lesson, and then I compared it with *the flow of the learning* from my lesson plan (See Figure 6.1).

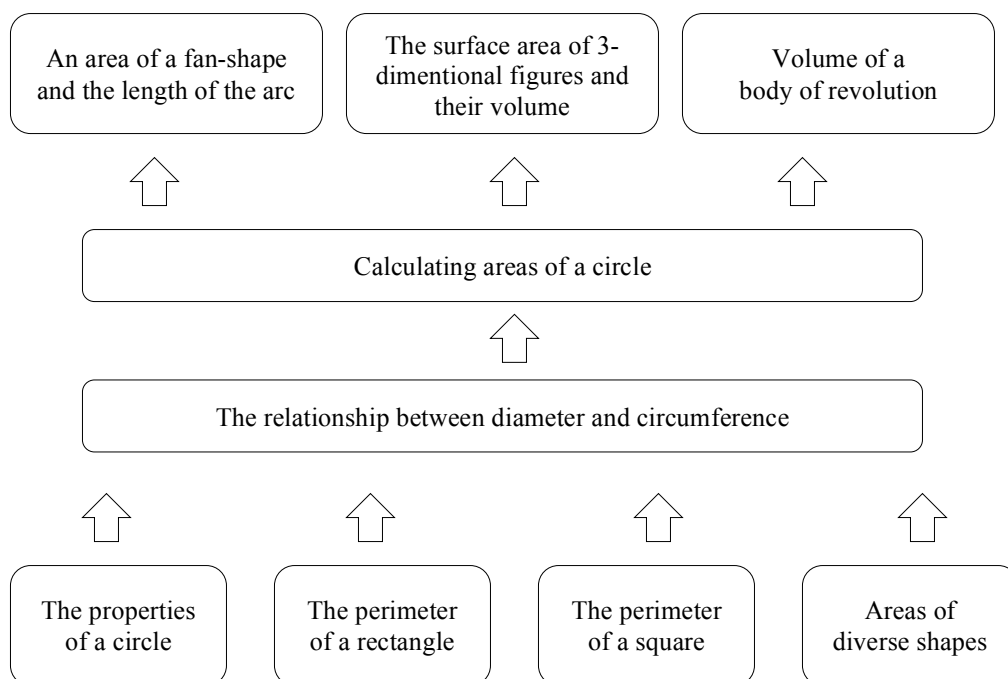

Figure 6.1. The Flow of Learning from Mr. Bae's Lesson Plan

After a pause, Mr. Bae continued to explain the major elements that characterize the flow of learning for his students. He placed emphasis on the importance of how students' knowledge or lack of knowledge of a skill or conceptual area may affect how he plans the lesson to support students' learning of the lesson objectives. He provided the following statement:

From today's lesson, my students were supposed to understand the relationship between a diameter and a circumference. So, my students should at least know the

properties of a circle to understand the relationship. If students did have knowledge about the diameter or circumference, I am not able to teach the relationship, right? However, they do not need to know about perimeter of a rectangle or a square for today's lesson. It would be great for me if my students knew it well, but understanding the perimeter of a rectangle or a square might not be essentially needed for today's class. Also, students must have the skill needed to measure the perimeter with a ruler and to calculate the perimeter with a formula in order to participate in today's class.

Interviewer: How about attitude? Students should have the attitude that you mentioned from the table in order to participate in today's lesson?

Mr. Bae: No, I need to know about it to make plans for supporting my students. If I do not know my students' current status, I may not make the appropriate plans for the class. For example, if they already like to find daily-lives mathematics problems, I may just give them opportunities to share their findings. Or, if they may not like it, I might need to provide mathematical activities that could relate to daily-lives mathematics problems that may help them develop an interest in real-life mathematics problems.

Interviewer: I'm wondering about specific student numbers found in the table. How did you figure out that 20 students had a high level of knowledge about the properties of a circle?

Mr. Bae: Well. Sometimes, I just know from the experience of teaching my students. If I do not know, sometimes I do a survey or conduct diagnostic tests.

Mr. Bae also reported that he needed to know the three aspects about students as

mathematics learners in order to support them to accomplish the objectives that were guided by the National Mathematics Curriculum. Based on the rationale for objectives of the National Mathematics Curriculum, Mr. Bae developed specific lesson goals. Again, Mr. Bae clarified his MLK about planning lessons according the objectives of the lesson.

Furthermore, the 11 teachers described how they had narrowed down the focused aspects of students' knowledge and skills considering their students' sequence of learning. The teachers developed a map in which they characterized *the flow of learning* based on their Mathematics Curriculum Knowledge, and they used the map for deciding which aspects of students' characteristics they may concentrate on during mathematics instruction.

The definition of MLK discussed in this section may be helpful in broadening our understanding of the participants' uses of MLK during mathematics instruction. In the following section, I focus on the results of analysis regarding teachers' use of MLK in their mathematics instruction with the most typical cases based on the conceptual framework presented in Chapter 1.

Mathematics Learner Knowledge in Mathematics Instruction

Based on the conceptual framework, this section presents results of the analysis that includes three stages of instruction: using MLK when developing an instructional process, using MLK when teaching the lesson, and using MLK when assessing students' works. As noted from Chapter 3, with data triangulation, this study produced generalized themes and codes that are founded in most of the cases of this study. To illustrate the teachers' use of MLK in their mathematics instruction, this section highlighted cases that are representative of the 11 participants.

Using MLK When Developing an Instructional Process

A key finding is the participants' systemic approach toward planning the mathematics lessons is based on their MLK. Based on their analysis of what they knew about their students, the teachers generated implications for mathematics instruction and used them for developing their lesson plans. For example, Mrs. Choi reported her MLK as shown in Table 6.4.

Table 6.4.

The Investigation on Students' Mathematical Background from Mrs. Choi's Lesson Plan

Categories	The target aspect of students	Results *	N (28)	%	Analysis
Students' Mathematical Knowledge /understanding	Do students know the basic concepts of a parallelogram?	Top	6	21	In general, students understand the basic concepts and features of a parallelogram, as they already have learned about it from their private institutions. However, most of them only memorized the definition of a parallelogram. When they viewed an atypical type of a parallelogram, they did not consider it to be a parallelogram.
		Middle	21	75	
		Bottom	1	4	
Students' Mathematical Skills	Can students draw diverse shapes of a parallelogram?	Top	19	68	There are students who cannot draw a parallelogram in diverse ways. Therefore, there needs to be an extra exercise for these students.
		Middle	6	21	
		Bottom	3	11	
	Can students measure the length by using standard-units and read gradation?	Top	25	89	In general, students can measure length by using standard units.
		Middle	3	11	
		Bottom	0	0	
Students' Mathematical Attitude	Are students involved in discover-centered mathematics lessons with interest?	Top	24	86	In general, students are involved in discover-centered mathematics lesson with interest.
		Middle	4	14	
		Bottom	0	0	

*Note. The terms top, middle, and bottom indicate how the teachers ranked learners according to their mathematics knowledge.

From her examination of the three key categories, Mrs. Choi made note of the implications for instruction in her lesson plan. She provided the following justification:

In general, students know the basic concepts and features of a parallelogram, although some students had difficulty drawing a parallelogram in diverse ways. Therefore, there is a need for a review of parallelogram to help students understand the basic concepts of the base and height of a parallelogram. In addition, a teacher should design manipulate activities that support students' discovery of basic mathematics concepts of a parallelogram by themselves.

Mrs. Choi found that some of her students had difficulty drawing a parallelogram in diverse ways, and she needed to provide an activity that might support students in finding various parallelograms through hands-on activities. During the third interview, Mrs. Choi clarified how she addressed these implications in her lesson plan, stating:

Based on the students' knowledge of the diverse features of parallelograms, I realized that my students had a certain image of a parallelogram. For example, some of my students believed that the first shape only is a parallelogram, while they thought that the second or third shape was not a parallelogram.

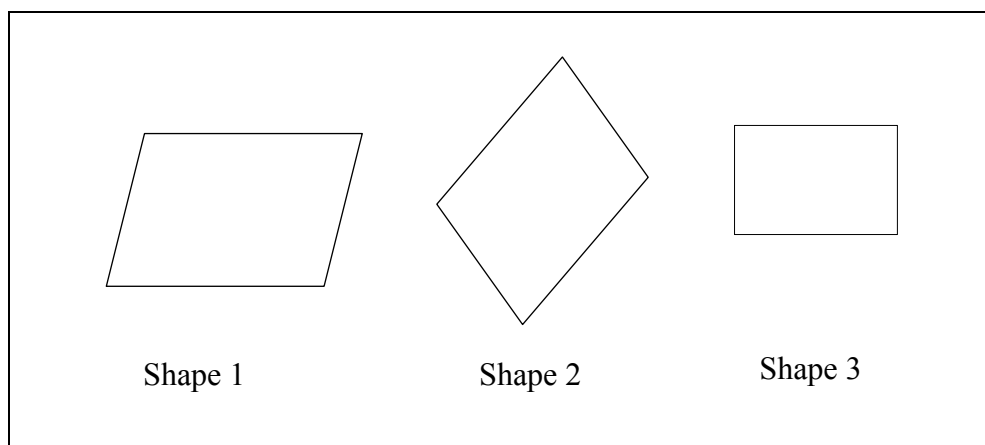

Figure 6.2. Diverse Parallelograms

The three shapes are illustrated in Figure 6.2. Mrs. Choi elaborated further, stating that it is important to support students' understanding. She continues:

Therefore, I need to help my students understand diverse types of

parallelograms. And I know that my students love to find the mathematics concepts by themselves rather than listen to my explanations. So I gave them tangrams and supported them as they made and found diverse shapes of a parallelogram. For example, my students made diverse shapes of parallelograms by themselves with only two pieces of the tangrams (See Figure 6.3)

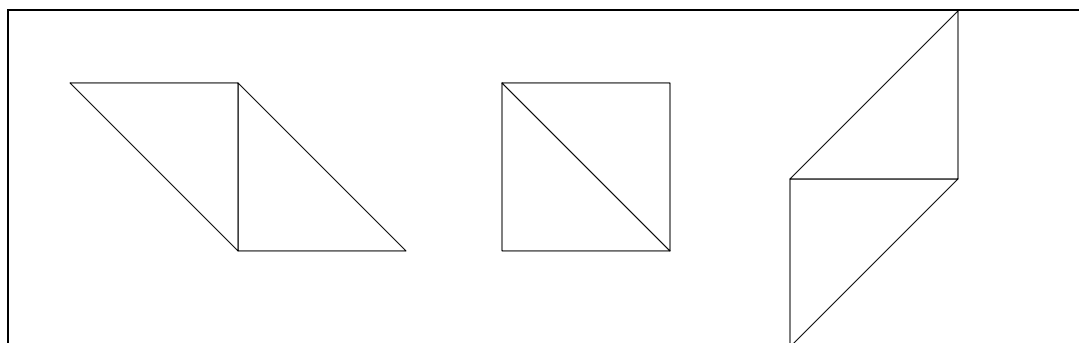

Figure 6.3. Diverse Parallelograms Made with Tangram Pieces

Mrs. Choi provided a description of her approach to the mathematics instruction as noted above based on her knowledge of students' mathematical understanding regarding parallelograms as well as the implications drawn from it. Mrs. Choi found that her students might have difficulties perceiving diverse types of parallelograms, thus she prepared a tangram activity that may support students' construction of diverse parallelograms. With this intention and based on her MLK, Mrs. Choi developed a detailed lesson plan, which is presented in Table 6.6.

Table 6.6.

Mrs. Choi's Lesson Plan Based on Her Students' Mathematical Background

Major Topic of the Lesson	Subtopic of the Lesson	Teaching-Learning Activities		Time (Minutes)	Materials (-) Notes (*)
		Teacher	Students		
Present questions	Checking what students learned from the last class	What did you learn from the last class? How did we learn it?	We calculated areas of diverse two-dimensional figures by using the area of a rectangle. We calculated areas in diverse ways.	5'	-Tangrams
	Motivating	<p>* A teacher helps students make diverse types of parallelograms with tangrams.</p> <div style="border: 1px solid black; padding: 5px; width: fit-content;"> <p>A big right-angle triangle 1, 2 A middle right-angle triangle, 3 A square, 4 A parallelogram, 5 A small right angle triangle 6, 7</p> </div> <p>* A teacher supports students as they think about how to make new figures with a parallelogram that they have already made in a previous activity. What kind of figures can you make?</p> <p>If you assume that the area of <6> or <7> is equal to 1, what is the area of each figure?</p>	<p>*Students make diverse types of parallelograms with tangrams.</p> <p>-With big right-angle triangles 1+2 - With small right-angle triangles 6+7 - A parallelogram itself is 5 - 6+4+7 -1+2+3+4+5+6+7 - Others</p> <p>* Students try to think about how they can make new figures by breaking a parallelogram that they have already made in a previous activity. I can make a rectangle and a square, etc. It is diverse, such as 2 or 4.</p>		
⋮	⋮	⋮	⋮	⋮	⋮

As illustrated in Table 6.6, Mrs. Choi offered detailed descriptions about her lesson activities based on the implications of her MLK. Mrs. Choi specified not only the activities that she is going to provide students during the lesson but also her students' possible answers and reactions while they participate in the activities. These systemic approaches to lesson plan development were also demonstrated in the lesson plans of all 11 participants. Another example regarding the use of MLK when developing lesson plans is Mrs. Jeong's case. Mrs. Jeong's MLK is shown in Table 6.7.

Table 6.7.

The Investigation on Students' Mathematical Background from Mrs. Jeong's Lesson Plan

Categories	The target aspect of students	Results*	N (42)	%	Analysis
Students' Mathematical Knowledge /Understanding	Do students know the basic concepts of parallel lines?	Top	30	71	In general, students understand the basic concepts of parallel lines. However, there are gaps among students. Therefore, there needs to be an extra plan for these students.
		Middle	7	17	
		Bottom	5	12	
Students' Mathematical Skills	Can students draw parallel lines on grid paper?	Top	12	29	Although some students can draw parallel lines using grid paper, some students cannot. There are students who cannot draw parallel lines using grid-paper. Therefore, there needs to be diverse types of activities based on students' skill levels.
		Middle	16	38	
		Bottom	14	33	
Students' Mathematical Attitude	Do students involved in a hands-on activity show interest in the lesson?	Top	37	88	Most students involved in a hands-on activity were interested in the lesson.
		Middle	5	12	
		Bottom	0	0	

* Note. The terms top, middle, and bottom indicate how the teachers ranked learners according to their mathematics knowledge.

Based on her analysis of three key categories as presented in Table 6.7, Mrs. Jeong reported implications for instruction in her lesson plan:

Most students understood the basic concepts of parallel lines that students were required to know to learn about a parallelogram. Also, most students like hands-on activities. However, students' abilities to draw parallel lines on grid paper seemed varied. Therefore, I need different types of activities based on students' drawing levels.

Mrs. Jeong realized that the class consisted of students who were at different skill levels regarding constructing parallel lines. Thus, she decided that to support students, it would be important to prepare diverse activities based on her students' skill levels. During the third interview, Mrs. Jeong explained her intention as follows, stating:

I found that my students' levels are varied in terms of their mathematical skills, while there were no significant gaps among students in both knowledge and attitude categories. Thus, I focused on how to involve students who have different abilities in the class. Therefore, I provided models to students whose skill levels were low. For the middle-level group, they also had models, but they had to create them with a geoboard. For the high-level group members, they created their own parallelograms based on their understanding. Although they could look at the parallelograms in the textbook, there were no gridlines in the textbook.

Based on her judgment, Mrs. Jeong decided to focus on her students' gaps in terms of mathematics skills and understanding during the lesson. For example, as there were students who had different abilities in drawing parallel lines, Mrs. Jeong prepared

different activities according to students' levels of understanding. With this intention, Mrs. Jeong developed a detailed lesson plan, which is presented in Table 6.8 based on her MLK.

Table 6.8.

Mrs. Jeong's Lesson Plan Based on Her Students' Mathematical Background

Major Topic of the Lesson	Subtopic of the Lesson	Teaching-Learning Activities	Time (Minutes)	Materials (-) Notes (*)
		Teacher & Students		
⋮	⋮	⋮	⋮	⋮
Development	Activity 2 [Group Activity based on performance level]	<p>*To understand what a parallelogram is</p> <p>-The low-performing group: Students may find parallelograms among diverse quadrangles, which are made on a paper. Then, they put the parallelograms on grid paper. Finally, students draw a parallelogram on grid paper by observing what they had pasted on the other piece of grid paper.</p> <p>-The middle performing group: Students may make a parallelogram with rubber bands on a geoboard. Subsequently, they draw a parallelogram on grid paper by observing what they had made on a geoboard.</p> <p>-The top group: Students may draw parallelograms on grid paper by observing parallelograms in the textbook.</p>	10'	-Grid-papers, geoboards, glue
⋮	⋮	⋮	⋮	⋮

As illustrated in Table 6.8, Mrs. Jeong specified differentiated activities according to students' performance levels based on the implications of her MLK. Observation of this lesson indicated that students engaged in diverse activities based on their mathematics performance levels according to the teacher's lesson plan. Figures 6.4a and 6.4b present examples of student engagement in the various activities developed by Mrs. Jeong. Also illustrated are graphic models of the work students completed as they engaged in activities designed to target their mathematics skill levels.

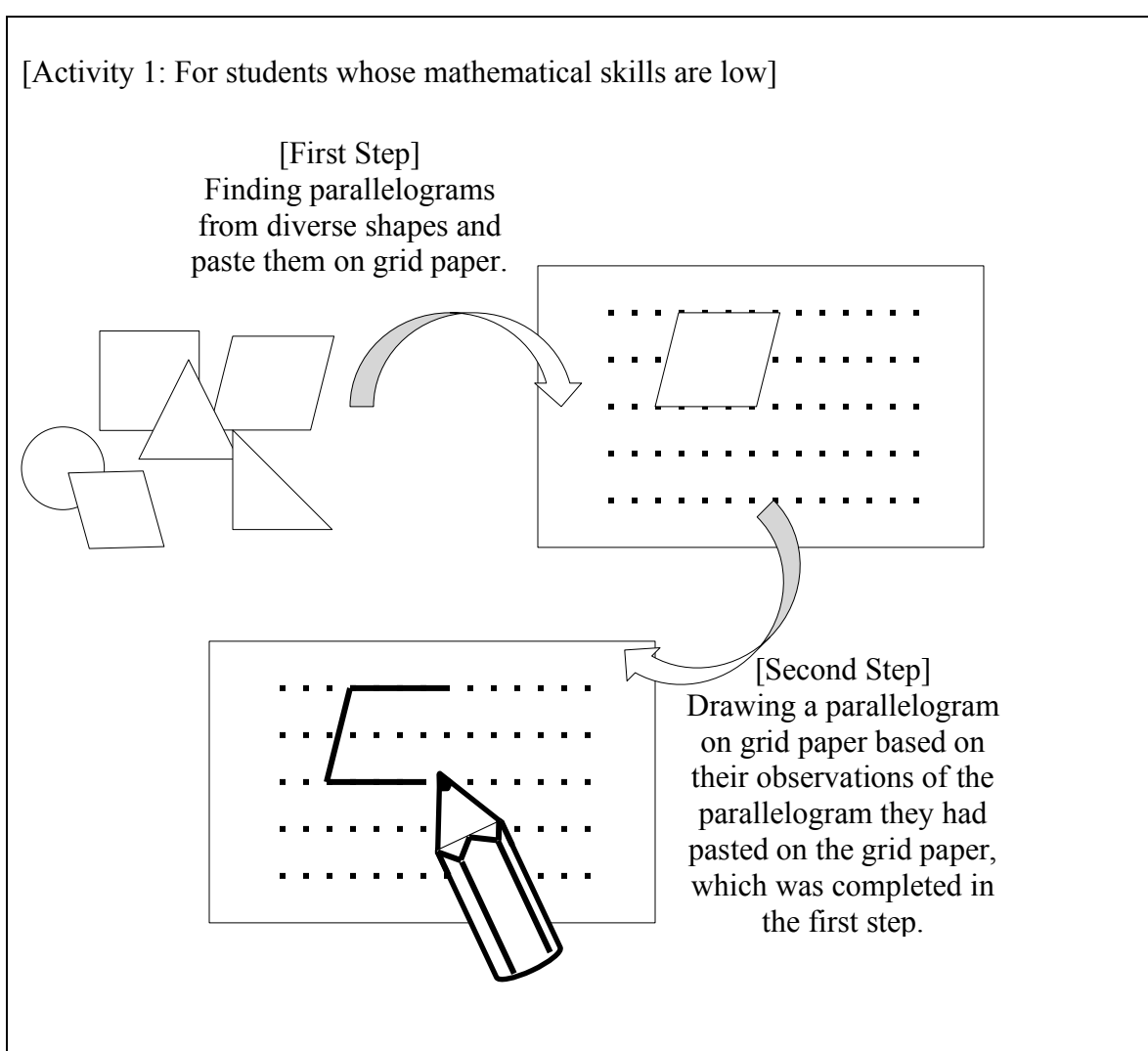

Figure 6.4a. The Process of Each Activity from Mrs. Jeong's Mathematics Instruction

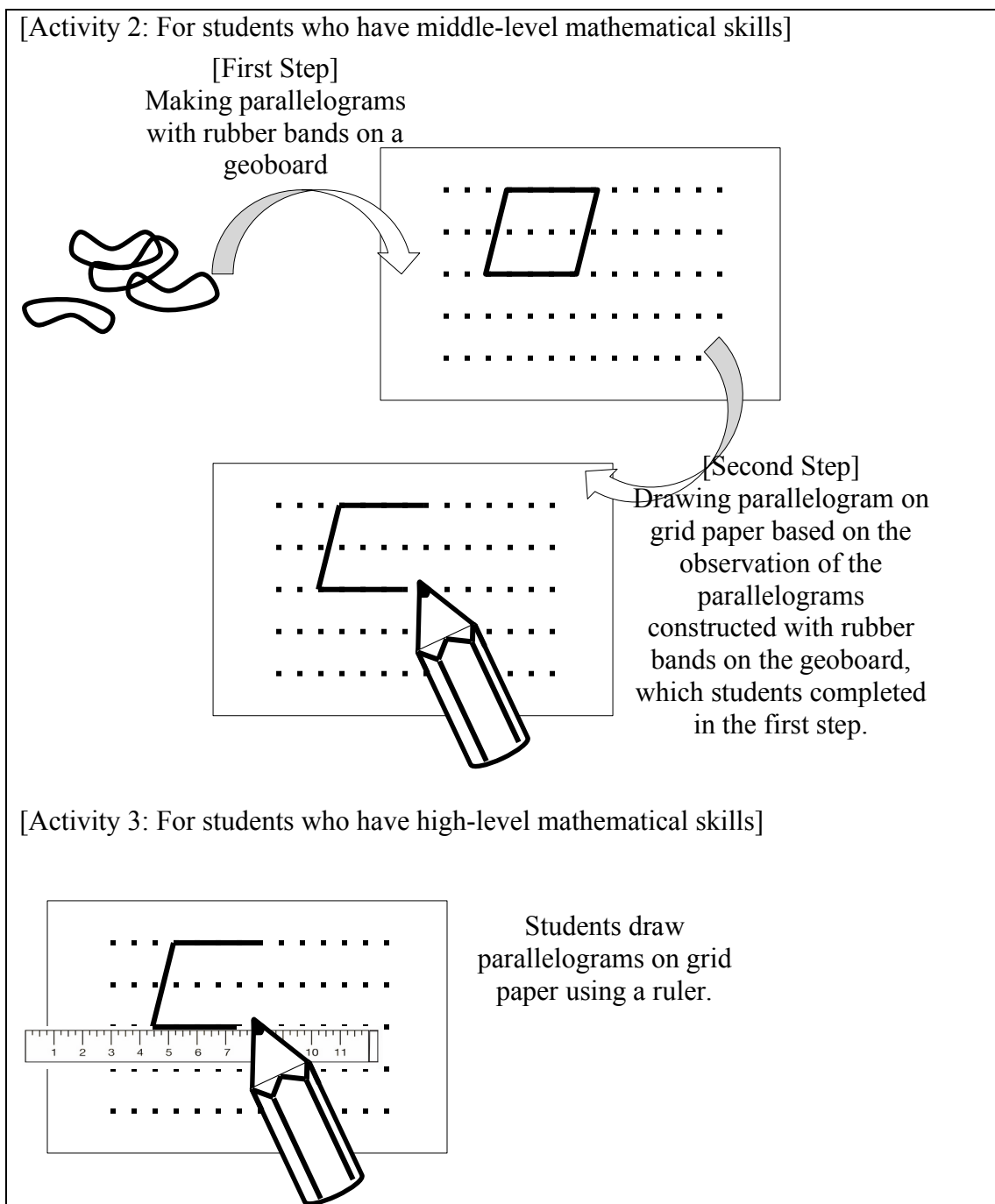

Figure 6.4b. The Process of each Activity from Mrs. Jeong's Mathematics Instruction

As illustrated in Figures 6.4a and 6.4b, Mrs. Jeong prepared different mathematical materials and activities according to the students' mathematics level. Mrs. Jeong's MLK provided the basis for constructing classroom activities according to

students' mathematics levels and for the instructional methods applied during mathematics instruction.

Analysis of the lesson plans and the subsequent observations of the lessons suggested that these teachers' MLK might have affected their decision-making process when designing lesson plans and activities that would support students' conceptual development. For example, Mrs. Choi developed activities that she thought would help her students improve their conceptual understanding of a parallelogram. On the other hand, Mrs. Jeong prepared diverse activities based on her students' performance levels in terms of mathematics skills. What this finding shares with other studies is that teachers do make instructional decisions that affect student learning (e.g., Robinson, Even & Tirosh, 1992; Robinson, Even & Tirosh, 1994; Fennema & Franke, 1992). However, what is different is that these teachers made use of their Mathematics Learner Knowledge when planning and developing their lessons and activities. As stated earlier in this chapter, the teachers surveyed or gave diagnostic tests their students to gather knowledge about what students know and understand about future concepts or topics. Thus to meet the needs of their students, teachers needed to consider what they knew about students' mathematics performance. Another interesting finding that emerges from the examination of the lesson plan, observation, and interview data is that teachers' lesson plans closely matched the actual teaching of the lessons. The decisions they made in advance teaching the lesson influenced their instructional activities.

Using MLK When Teaching the Lesson in a Classroom

Analysis of observation and interview data indicates that the teachers communicated with their students based on the teachers' MLK. The teachers in this study

supported their students' in-depth development of mathematics concepts as the conversation progressed in a classroom based on their MLK. For example, during the observation of Mr. Ro's lesson about the basic concepts of a cube, he communicated with his fifth-grade students as illustrated in the following excerpt.

Mr. Ro: Could you please tell me about what you found from the observation of cubes?

What are the common properties among diverse cube-shaped boxes? (Most of the students raised their hands.) Dae-Hyun?

Dae-Hyun: I found that there are some letters on the outside of the boxes.

Mr. Ro: Good job. Is there anyone who found the same thing as Dae-Hyun? (About 10 students raised their hands.) Yu-Na?

Yu-Na: I do not agree with Dae-Hyun's findings. See, some of my boxes do not have letters. And this box has some figures outside.

Mr. Ro: Good. Anyone else? Jong-Hak?

Jong-Hak: I agree with Yu-Na. All boxes have different colors and designs. So, I think ... we may not say these things are common properties of cubes. When we say common properties, they should be applied to all cases of cube-shaped boxes.

The discussion in Mr. Ro's mathematics classroom illustrates the process of extracting abstract mathematics concepts of a cube based on the observation of boxes in students' real lives. The communication started with a student's misconception about common properties of cubes and progressed to discussing how to define common properties of figures. From the interview, Mr. Ro explained that he had selected a student who had a misconception on purpose to engage students in a rich discussion about common properties of cubes, stating:

I know each student's mathematics level and each one's ability pretty well. So, I can expect the answers before the students say them. For example, students with high mathematics academic achievement tend to say the right or perfect answer usually. This is not a problem at all. However, their perfect answers may take away other students' opportunities to think deeply about the concept. On the other hand, students who had low academic achievement tend to provide wrong answers. They are usually wrong, but sometimes their answers are creative, providing more space for the other students to think. The other students may have a chance to think about why these answers are wrong. Therefore, when I want to support my students to think deeply, I usually start the conversation with students who may have wrong or creative answers. But, when I want to clarify the mathematics concepts and make sure that my students understand what they have learned, students who might give the right answer are provided an opportunity to talk.

Mr. Ro's statement demonstrates the strategies he uses to communicate with his students during a mathematics lesson. Mr. Ro's communication process is based on his understanding of students' mathematical background and the instructional approach.

When Mr. Ro wants students to think deeply about the mathematics they are learning, his initial communication process starts with students who may offer the class wrong or creative answers. If Mr. Ro wants his students to understand the mathematics concepts clearly, he purposely provides students who might have the right answer an opportunity to engage in the communication process.

Mrs. Kim applies a different communication strategy based on her MLK. During the third interview, Mrs. Kim described how she used MLK in when teaching a lesson,

asserting:

Based on my understanding of my students, [I see] there are a couple of students who do not like group activities. They also do not like to talk in front of the class. They are quiet and timid. I did not force them to talk during the classroom conversation or to participate in a group activity during a mathematics lesson. I prepared work that they can do by themselves. If I force them to do the same thing just like the other students, it may cause math anxiety.

Interviewer: Mrs. Kim, please explain more about math anxiety.

Unlike other subjects, mathematics usually has a right answer. When shy students give the wrong answer in front of other students, it might be an embarrassing experience for them. And I think that this is one reason that causes math anxiety, such as getting nervous when they solve mathematics problems.

Mrs. Kim reported that she communicated with students considering their attitude or mathematics backgrounds. Mrs. Kim's argument is that it is essential not to force students to talk during the mathematics lesson. Using this strategy is her way of preventing math anxiety. The other nine teachers also reported that they consider students' cognitive and emotional statuses to achieve effective communication with them during a mathematics lesson.

Lampert (2001) argued that teachers might control the mathematics discussion by selecting particular students to share their work with the rest of the class. To select the right student for a productive mathematics discussion, Smith and Stein (2011) asserted that teachers should observe students' work carefully during the mathematics lessons. However, the findings of this study demonstrated that MLK also affect teachers'

decisions on selecting students for mathematics discussion. The teachers anticipate students' answers before they choose them to engage in the class discussions.

Anticipating students' answers in advance is a strategy used to support student learning and to guide the mathematics discussion.

Using MLK When Assessing Students' Work

The teachers used MLK when they assessed students' work. The following scenarios from the analysis of the transcript of the second interview relates to assessing students' mathematical works (See Appendix C). The teachers were asked to examine a subtraction problem with regrouping that was completed by a second-grade child. Mr. Ki showed how he applied MLK when assessing the student's work, stating:

There is one thing that bothers me. There is a line between the numbers in the problem like 2 | 3 instead of 23. Students may have a chance to recognize the numbers separately based on my experience. Like 2 and 3, not 23. Anyway ... if the student really doesn't know the basic concepts, she has to learn place value, subtraction, and regrouping. However, in this case, the second-grade student may not understand the meaning of the line between numbers because he or she may not think abstractly. Before I assess the student's work, I need to check whether the student understands the meaning of the line or not.

Interviewer: What are you going to do? I mean if the student exhibits the same issues after showing that she knows the meaning of the line?

Mr. Ki: Well. Then, she has to learn everything again. And, if her parents are helpful, then I could tell the truth to her parents and get some help from them. But, I'm not sure that would be helpful to her.

Interviewer: What do you mean? Extra class or help from her parents?

Mr. Ki: Honestly, both of them. You know, students learn the basic concepts of numbers for almost an entire year of their first year in school. And her worksheet shows that she does not understand at all. So, probably, she might have some intellectual issues. I know that there are possibilities that her teacher or parents might cause her issues. But, this case, I don't think so. Look at her handwriting. Isn't it beautiful? This means that her teacher or parents paid attention to her studying. If they did not care about her, her handwriting should be messy. This may prove that her parents and previous teachers took care of her carefully. So, it seems like an intellectual issue.

Ten of eleven teachers pointed out the same issue as Mr. Ki had. The teachers said that the second-grade student might be confused because of the line between two-digit numbers, as second-grade students might not think abstractly. This may show that the teachers' knowledge on students' knowledge and understanding of numbers and operations might affect their assessment of student work. Similarly, Mr. Cho used his MLK when he was required to assess a student's mathematical work during the second interview, proposing:

Mr. Cho: Is it one student's paper, right?

Interviewer: Yes, is there anything wrong?

Mr. Cho: Well, it seems like many students solved it together.

Interviewer: Could you explain more about that?

Mr. Cho: This student tends to subtract smaller numbers from larger numbers regardless of the numbers' locations. But she wrote correct answer for two problems.

Usually, students tend to solve problems the same way, so it is not common for students to find only one correct answer. And here, she wrote 07 instead of 7. So, probably, she does not understand the basic concept of zero. And here she did regrouping correctly, but she left the number, which is in the ten place.

Interviewer: You said that these errors couldn't be found in one student, right?

Mr. Cho: Yes, based on my experience, one student has a typical type of error or two errors. But, here, I can see so many types of errors. In this case, a student tends not to write answer like this. I mean she tried to think and answers correctly. But, usually students who have severe mathematical issues and do not like solving problems tend to write nothing or meaningless numbers, such as 1, 1, 1, 1 for all answers. When a student writes answer with this passion, that means ... a student has confidence in her answers. Well, strange.

Mr. Cho pointed out the unsystemic errors in the student's mathematical work and interpreted these errors based on his understanding of students' mathematical abilities or attitude toward mathematics. Eight of eleven teachers, similar to Mr. Cho, also suggested there are too many types of errors on the worksheet. The teachers considered students' behavior patterns when assessing their students' work. This finding shows that the teachers do not assess students' work based only on their knowledge in mathematics content. The teachers used their MLK, which included understanding of students' knowledge or attitude including behavior patterns (e.g., handwriting, number of mathematics errors).

There are attempts to assess teachers' knowledge for teaching mathematics based on teachers' judgments about students' work (e.g., Hill, Schilling, & Ball, 2004; Ng,

2011; Dalaney, Ball, Hill, Schiling, & Zopf, 2008). These quantitative evaluations on teachers' knowledge for teaching were developed based on the assumption that teachers might react to students' works in similar ways. However, as shown by the South Korean teachers, to assess students' work properly means that teachers must go beyond the examination of right answers or procedures. The teachers considered students' ways of perceiving the problem, prior knowledge, attitude including behavior patterns, and the cause of the students' mathematical misunderstanding. The findings are in keeping with previous studies' outcomes, which suggest that elementary teachers should have broad and deep knowledge of students' nonstandard strategies as well as have ways to deal with them (Empson & Junk, 2004; Anderson & Kim, 2003; Kleve, 2010).

Interpretive Summary

In attempting to analyze various types of data, this study found that Mathematics Learner Knowledge is one of the essential categories of an elementary teacher's knowledge for teaching mathematics that integrates with the whole instructional process: planning the lesson, teaching the lesson, and assessing student learning.

From the analysis of lesson plans of the 11 participants, the researcher discovered that the subcategories that emerged for South Korean elementary teachers' Mathematics Learner Knowledge were students' mathematical knowledge/understanding, students' mathematical skills, and students' mathematical attitude. These three key subcategories were characterized based the objectives of the lessons that were developed according to the National Mathematics Curriculum. The teachers reported on students' characteristics according to the subcategories in their lesson plans and used implications from them when they designed the lesson's mathematical activities. Additionally, the teachers used

their Mathematics Learner Knowledge when they communicated with students as well as when they assess students' mathematical works in which they anticipated students' answers to questions posed. Teachers also considered students' mathematical knowledge, skills, and attitude. Although diverse studies assert that teachers should know their students to effectively teach math (e.g., Ball, Thames & Phelps, 2008; Fennema & Franke, 1992), and teachers' understanding of their students might be key to consist Pedagogical Content Knowledge (e.g., An, Kulm, & Wu, 2004; Shulman, 1987), there were not many discussions on what teachers should know about their students as mathematics learners. Defining students' characteristics might be difficult, as there are too many things to consider when trying to understand students as mathematics learners. However, the three key subcategories that related to a lesson's objectives were useful to the teachers participating in this study when they developed lesson plans, taught the lesson, and assessed student learning.

Another major finding of this chapter is that Mathematics Learner Knowledge might have a complementary relationship with teachers' Mathematics Curriculum Knowledge. When the teachers analyze their students' mathematical backgrounds, they consider students' learning history according to the National Mathematics Curriculum, which were defined as Mathematics Curriculum Knowledge in the previous chapter. In the lesson plans, the teachers surveyed their students' mathematical knowledge based on what they were supposed to learn in their previous learning. Similarly, when the teachers assess students' works, the teachers diagnose students' level based on what they should know due to their learning history. This indicates that the teachers use diverse categories

of knowledge for teaching mathematics by integrating them rather than by relying on a single category.

This chapter presented findings about South Korean elementary teachers' Mathematics Learner Knowledge, illustrating that Mathematics Learner Knowledge integrates with planning, teaching, and assessing. Chapter 7 presents findings about the third category of elementary teachers' knowledge for teaching mathematics: Fundamental Mathematics Conceptual Knowledge.

CHAPTER 7

Knowledge for Teaching Mathematics Category III: Fundamental Mathematics Conceptual Knowledge (FMCK)

In previous chapters, this study revealed that Mathematics Curriculum Knowledge and Mathematics Learner Knowledge might play a significant role in South Korean elementary teachers' knowledge for teaching mathematics. This chapter focuses on the third category of elementary teachers' knowledge for teaching mathematics:

Fundamental Mathematics Conceptual Knowledge. The third category of knowledge for teaching mathematics discussed in this section is related to teachers' understanding of mathematics content.

As discussed in Chapter 2, teachers' knowledge of the mathematics content is more than just simply memorizing facts or procedures; teachers' knowledge of content should comprise understandings of the subject and its organizations (Grossman, Wilson, & Shulman, 1989; Shulman, 1987; Wilson, Shulman, & Richert, 1987). In addition, teachers' knowledge should be distinguished from nonteachers' knowledge of a subject because teachers' knowledge should include structure knowledge, which indicates the theories, principles, and concepts of a particular discipline (Shulman, 1992).

The teachers in this study have in-depth knowledge of mathematics content including definitions of mathematics terms, various ways of solving problems, and mathematics concepts. During the analysis of data, a number of codes and themes related to knowledge regarding mathematics content emerged. This section illustrates teachers' knowledge of mathematics concepts because it was the only code that was continually found in three stages of mathematics instruction as defined in the Conceptual Framework of this study. Although the teachers' knowledge of solving mathematics problems and

mathematical definitions emerged in the process of assessing students' mathematics works, their knowledge of solving mathematics problems and mathematical definitions was not evident in the process of preparing lessons, which is a major aspect of mathematics instruction. These findings are also allied with Fennema and Franke's (1992) arguments that conceptual understanding of mathematics is a notable characteristic of teachers' knowledge of mathematics.

Therefore, this chapter starts with a discussion of the definition for *Fundamental Mathematics Conceptual Knowledge* and the key subcategories of it. The first section also includes a brief investigation of the meaning of the term concept, as it provides a basic understanding of Fundamental Mathematics Conceptual Knowledge. The second section presents the results of data analysis regarding the participants' use of Fundamental Mathematics Conceptual Knowledge in their mathematics instruction. This chapter concludes with an interpretive summary of the major findings.

Fundamental Mathematics Conceptual Knowledge

To understand the teachers' Fundamental Mathematics Conceptual Knowledge, it is important to define the term *concept*. Concepts imply the component of thoughts, which enable the individual to categorize, infer, memorize, and learn. Concepts are mental representations that exist in the brain and mediate between thought, language, and referents (Margolis & Laurence, 1999).

In mathematics education, mathematics concepts indicate both the mental representations that are derived from sensory experiences and the relationship among the representations (Skemp, 1989). For example, students may develop the mental representation of a rectangle based on their experiences. The mental representation of a

rectangle becomes more sophisticated by connecting it with other mathematics concepts such as the concept of square, triangle, or circle. When comparing similarities and differences with other shapes, students may verify their concept of a rectangle (See Figure, 7.1).

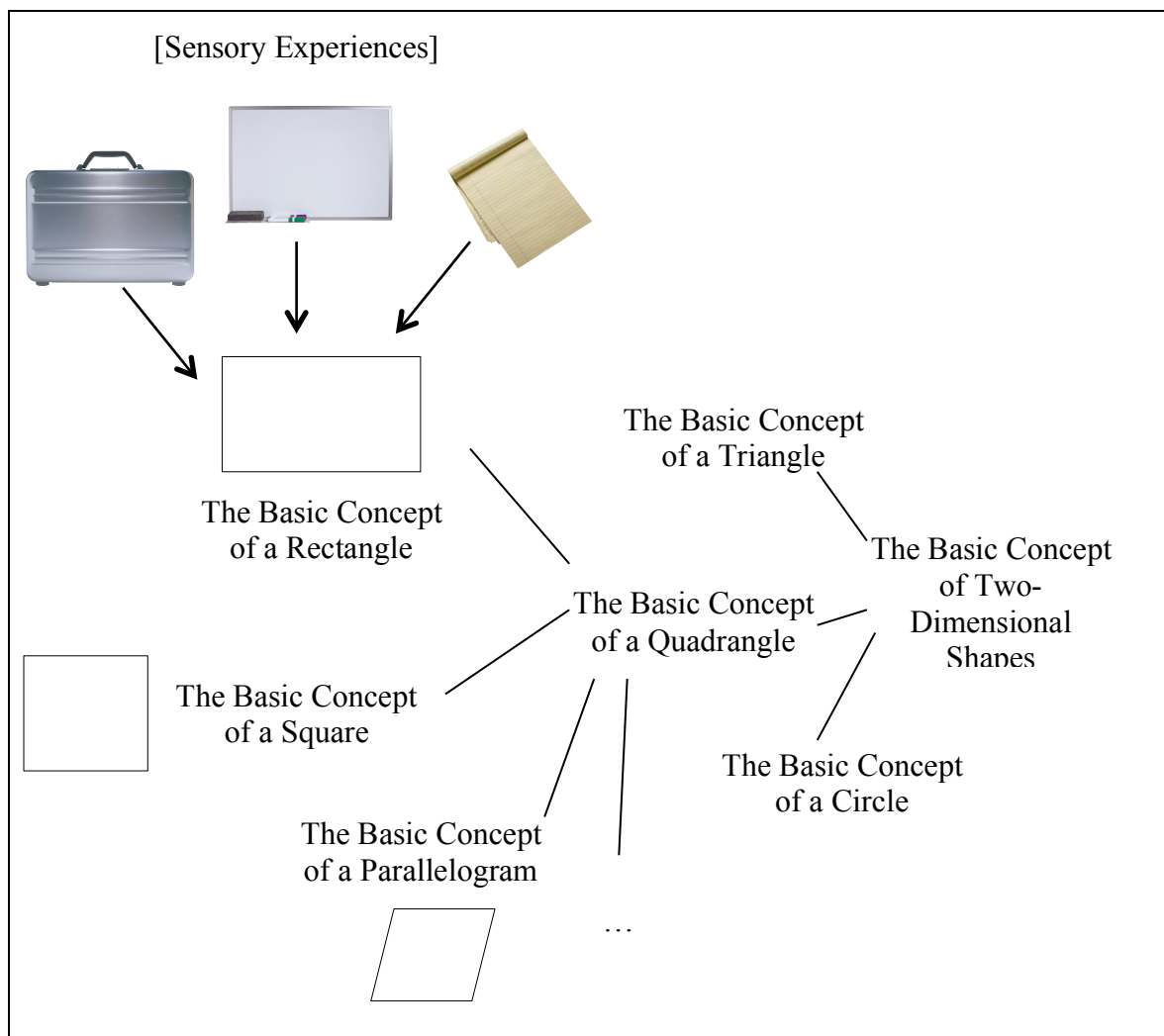

Figure 7.1. An Example of Concept of a Rectangle

Students who have an understanding of mathematics concepts may generate new mathematical knowledge rather than relying on memorization based on repetition (Kilpatrick, Swafford, & Findell, 2001). Therefore, teachers should help their students understand mathematics concepts. In this case, the formation of mathematics concepts

happens in the students' own minds, thus teachers support their students' natural learning process of developing mathematics concepts based on their (the teacher's) rich knowledge of mathematics concepts (Skemp, 1989). However, the mathematics concepts that teachers must know for teaching mathematics are still not mapped clearly despite their significance, as most of these studies relied on single-teacher case studies or studies of new teachers (Hill, Shilling, & Ball, 2004). In addition, most studies attempt to investigate what mathematics concepts the elementary teachers should know, rather than how elementary teachers develop their mathematics instruction based on their knowledge of mathematics concepts. Teachers' knowledge of mathematics concepts might differ from elementary students' understanding of mathematics concepts; teachers should know how to support their students' development of mathematical mental representations and the relationship among them in the classroom based on their knowledge of mathematics concepts (Fennema & Franke, 1992).

From the analysis of data, this study found the South Korean elementary teachers have in-depth knowledge of mathematics concepts and that they use that knowledge in their mathematics instruction. This research presented in this chapter refers to teachers' knowledge of mathematics concepts as Fundamental Mathematics Conceptual Knowledge (FMCK). FMCK designates teachers' understanding of mental representation of mathematics content and the relationship among them. In addition, it includes knowledge that may convert abstract mathematics concepts into a form, which enables learners to understand them. Although there are some studies that might define teachers' knowledge of representing and formulating the mathematics concepts that make it understandable to students as Pedagogical Content Knowledge (e.g., An, Kulm, & Wu,

2004; Fennema & Franke, 1992), this study assumed that FMKC might include both mathematics concepts and representation of them in a mathematics classroom. Teachers' knowledge of mathematics concepts and their representation in mathematics instruction are indivisible relations, and knowledge of representing mathematics concepts in the classroom may distinguish teachers' knowledge regarding mathematics concepts from students' conceptual knowledge.

FMCK is divided into two subcategories according to Skemp's statement that mathematics concepts may comprise both the mental representations that are derived from sensory experiences and the relationships among the representations (Skemp, 1989). Thus, the two subcategories are Intrinsic Mathematics Conceptual Knowledge (IMCK) and Extrinsic Mathematics Conceptual Knowledge (EMCK). IMCK demonstrates teachers' knowledge of abstract mental representation about mathematics content and how to provide sensory experiences to students to support the development of mental representations. EMCK illustrates teachers' knowledge regarding the relationship among mathematical mental representations and how these are presented during a mathematics lesson in order to support their students' understanding of them. For example, when teachers teach the basic concepts of multiplication, teachers may focus on the basic abstract mental representation of the concept of multiplication, such as repeated addition, by presenting an equation based on their IMCK. On the other hand, teachers may connect the basic concept of multiplication to the basic concept of a whole number; they may present models of multiplication by applying the concepts of continuous quantity and discrete quantity based on their EMCK as shown in Figure 7.2.

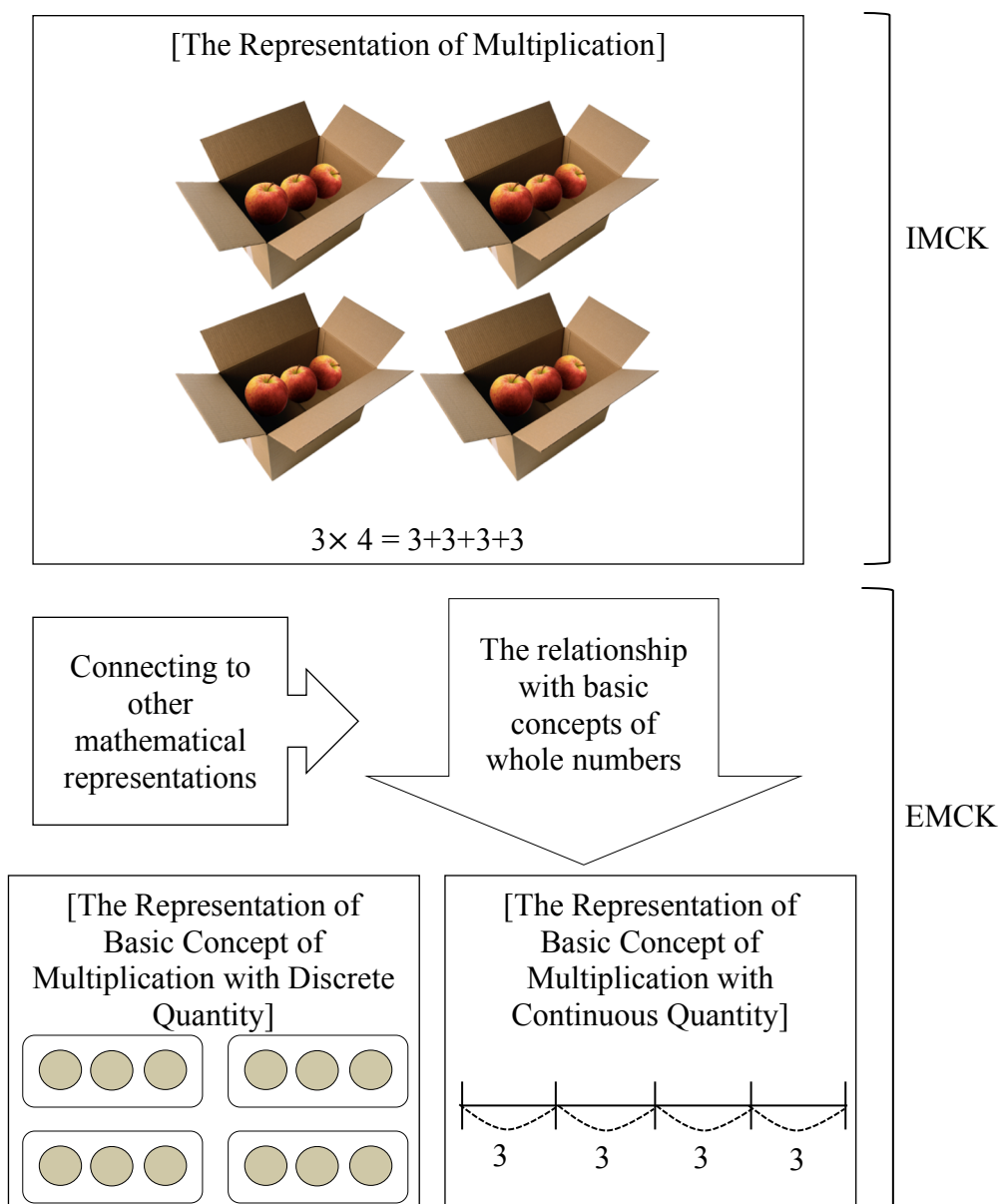

Figure 7.2. Example of IMCK and EMCK

Fundamental Mathematics Conceptual Knowledge in Mathematics Instruction

Based on the conceptual framework, this section presents results of the analysis, which includes three stages of instruction: using FMCK when developing an instructional process, using FMCK when teaching the lesson, and using FMCK when assessing students' works.

Using FMCK When Developing an Instructional Process

Results of analysis of the lesson plans and related interviews revealed that the teachers used FMCK when they prepared mathematics lessons. Although the teachers did not specify their FMCK in their lesson plans, excerpts from the third interview show that the teachers used their FMCK when they developed lesson plans. In particular, the teachers used both IMCK and EMCK when they designed activities to assist students' understanding of mathematics concepts. Although this section includes representative examples, all 11 teachers provided information about their understanding of mathematics concepts and related content during their interviews.

For example, Mrs. Lee taught the basic concept of standard units of area to her fourth-grade students during the mathematics lesson. To provide sensory experiences for developing the mathematical representation of standard units, the teacher used tangrams. The following passage from Mrs. Lee's third interview shows her use of IMCK when she designs activities in the mathematics lesson. As discussed above, IMCK includes teachers' understanding of mathematics representations and how to develop sensory experiences in order to support students' development of abstract mental representations. Mrs. Lee planned to use tangrams to teach the basic concept of standard units for calculating areas. Mrs. Lee explained why she chose tangrams based on IMCK, explaining:

Usually, students just try to memorize that they can calculate the area of a rectangle by multiplying the width by the length. However, I believe that they have to know the basic concepts of a standard unit in order to calculate areas of two-dimensional shapes. In fact, to calculate an area of a rectangle is equal to counting the number of standard units in a rectangular region. Therefore, I believe

that students have to realize the need for a standard unit in order to calculate an area of a two-dimensional shape. Thus, I chose tangrams. Each piece of tangrams has a certain relationship with each other in terms of area. When we say that the area of the smallest triangle of tangrams is equal to 1, the areas of the other pieces of tangrams are equal to 1, 2, or 4 (See Figure 7.3).

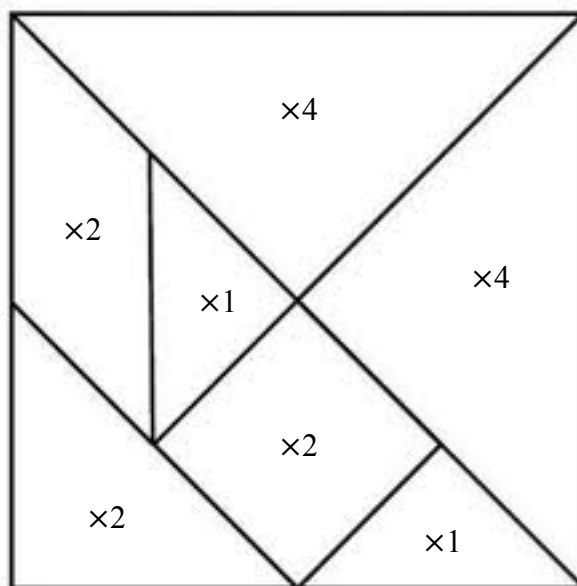

Figure 7.3. The Structure of Tangrams

Figure 7.3 demonstrates the relationship of areas among pieces in tangrams. Based on her observation of tangrams, Mrs. Lee connected this relationship to the mathematics content she is going to cover during mathematics instruction. Mrs. Lee explained her intention from her third interview, stating:

From my lesson plan, I planned to give tangrams to my students and have them place the pieces in order according to size. I wanted my students to find that if they set the smallest triangle as a unit, then they can compare the area of each piece easily. Based on this activity, students may understand the basic concept of a standard unit for area.

Based on her IMCK, Mrs. Lee decided to use the relationships among pieces of tangrams in order to provide sensory experiences regarding the concepts of standard units for calculating area. With this intention, as Mrs. Lee revealed from the interview, she had developed the lesson plan as follows.

Table 7.1.

Part of Mrs. Lee's Lesson Plan I

Major Topic of the Lesson	Sub-topic of the Lesson	Teaching-Learning Activity		Time (Minutes)	Materials (-) Notes (*)Notification
		Teacher	Students		
⋮ To understand the needs for a unit	⋮ Activity 1	⋮ -A teacher gives tangrams to the students. • Can you order the tangram pieces according to their size [i.e., area]? Please think about how we can compare the area of each piece. • Can you show us your decision and the way of ordering them according to size?	⋮ -Students compare areas of each tangram piece. • Students explain how they ordered the pieces.	⋮ 10'	⋮ -Tangrams
⋮	⋮	⋮	⋮	⋮	⋮

From the lesson plan, I discovered that Mrs. Lee planned to start the activity by having students use observations to make comparisons according to the size of the tangram pieces. Then, Mrs. Lee wanted students to explain what they had found from their observations.

Mrs. Lee also used her EMCK when she developed an activity for explaining mathematics concepts to her students. As defined above, EMCK indicates teachers' knowledge about the relationship among mathematical mental representations and how to present them during a mathematics lesson for students' mathematical understanding. Mrs. Lee used her knowledge about the relationship between centimeter (cm) and centimeter-square (cm^2). In particular, Mrs. Lee focused on the common aspects of two standard units; both of the standard units were developed to overcome the inconvenience of arbitrary units such as a hand-span. The following excerpt from Mrs. Lee's third interview demonstrates how she used EMCK when she planned the activities. Mrs. Lee explained why she planned to introduce 1 centimeter-square (cm^2) by comparing it with 1 centimeter (cm), stating:

From the lesson plan, I planned to introduce the unit of 1 centimeter-square (cm^2) by comparing it with the concept of 1 centimeter (cm) for the length. When we teach the concept of 1 centimeter (cm), we help students understand the inconvenience of arbitrary units such as one hand-span. Students may have difficulties with measuring a length with arbitrary units because everyone has a different length of a unit. That's why we need a standard unit such as 1 centimeter (cm) for length. It may be hard to find an arbitrary unit for calculating area. Therefore, I planned to support my students understanding of a standard unit by having them compare it with a standard unit for a length.

From the interview, Mrs. Lee specified that she used the relationship between two mathematical representations: centimeter and centimeter-square. The former is a standard unit for length, and the latter is a standard unit for area. Based on her EMCK, Mrs. Lee

developed the lesson plan as shown in Table 7.2.

Table 7.2.

Part of Mrs. Lee's Lesson Plan II

Major Topic of the Lesson	Subtopic of the Lesson	Teaching-Learning Activity		Time (Minutes)	Materials (-) Notes (*)
		Teacher	Students		
⋮ To understand the standard unit for calculating areas	⋮ Activity 1	⋮ -A teacher supports students' understanding of 1cm^2 by comparing it with 1cm . • Can you remember why we use 1cm to measure length? • What was the problem when we used different units such as a span? • Let's think about areas. What do you need in order to get the same results when we calculate area? • What do you think is the best unit for calculating area? Can we explain why?	⋮ -Students understand the needs for a standard unit for calculating areas. • Students answer the question. • The length can differ based on who measured it when they use different units. • We need a standard unit. • I want to use 1cm^2 , because we use 1cm for the standard unit of length. Etc.	⋮ 5'	⋮ * If students cannot answer properly, a teacher may change the questions to help students answer properly.
⋮	⋮	⋮	⋮	⋮	⋮

From the lesson plan, it is apparent that Mrs. Lee focused on the relationship between two standard units to support students' understanding regarding the need for standard units to calculate areas. The teachers' use of FCMK is found in other cases, too. For

example, Mr. Ki also used IMCK and EMCK when he designed activities to teach how to add two digit numbers. When Mr. Ki planned activities to support his students to develop the mathematical representation regarding addition with natural numbers, he considered two sensory experience models based on his IMCK. The analysis of the third interview data shows that Mr. Ki's knowledge is related to mathematical representation of addition. Mr. Ki explained why he designed two mathematical situations for one activity, which focused on students' understanding of addition, stating:

We can interpret addition in two ways. First, we can combine two different groups for addition. Second, we can also insert an extra amount into the original group.

While he was talking, Mr. Ki drew a model for each case illustrating mathematics concepts related to addition as presented in Figure 7.4.

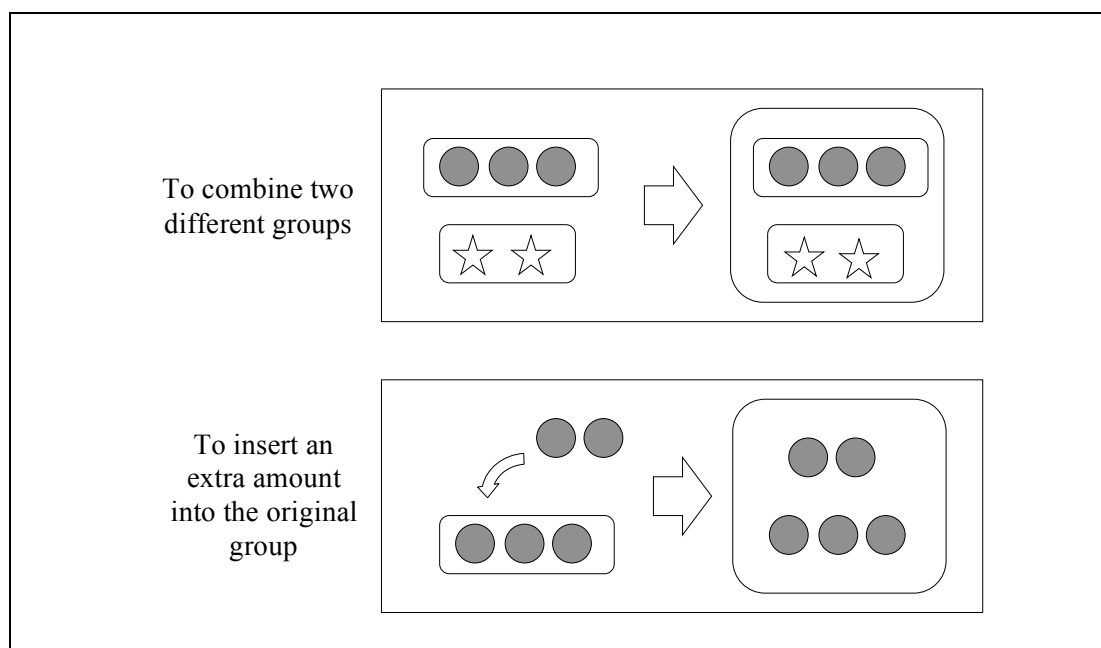

Figure 7.4. Two Sensory Experience Model for Addition with Natural Numbers

Based on his understanding of the mathematics concepts of addition, Mr. Ki explained how he used his knowledge for developing mathematics activities, stating:

Students do not need to distinguish between these two situations, but they have to

understand that we use addition in both cases. So, I provided two activities for each case to my students. I believe that my students can realize that they have to use addition when they solve word problems related to addition.

Mr. Ki's explanation presented above shows that he has rich IMCK about the basic concept of addition. Mr. Ki knew diverse sensory experiences that related to addition and designed diverse mathematical activities based on his knowledge. At the same time, Mr. Ki applied his EMCK based on the relationship between the mathematical concepts of addition and whole numbers. In his lesson plan, Mr. Ki used different types of manipulatives for diverse activities. First, Mr. Ki used base-ten blocks for Activity One. Second, Mr. Ki used a number line for Activity Two. Mr. Ki explained why he prepared two different manipulatives and how it might be connected to his EMCK, stating:

I believe that base-ten blocks are good for representing discrete quantities and that the number line is proper for representing continuous quantities. Although the topic of the lesson was addition, I thought that I had to help students experience calculating with both a discrete quantity and continuous quantities. In fact, I wanted to develop more questions that related to continuous quantities such as length, weight, or volume. But my students only learned about how to tell time in first grade, so I had to develop one question on telling time.

The excerpt from the third interview's transcript presented above illustrated that Mr. Ki has EMCK. Based on his EMCK, Mr. Ki made a connection between the basic concepts of whole numbers and addition. Mr. Ki's EMCK influenced the development of his lesson plans as shown in Table 7.3

During the development of the lesson plans, Mr. Ki reflected on his knowledge about the relationship between mathematical concepts of addition and whole numbers. Mr. Ki combined the concepts of addition with both discrete and continuous quantities and prepared different types of manipulatives or mathematical representations for students. This was not unique to Mr. Ki's case. The other teachers including Mrs. Lee and Mr. Ki developed activities that clarified the relationship among mathematical concepts and extracted meaningful implications from the process. The teachers developed activities based on their ICMK and expanded the range of activities based on their ECMK. In addition, the teachers provided activities that contain integrated mathematics concepts rather than explaining the relationship among mathematics concepts directly. This may show that FCMK is the significant factor for designing activities that support students' development of mathematical concepts.

Using FMCK When Teaching the Lesson in a Classroom

The teachers used their FMCK during the conversation with the students in their mathematics classrooms. In particular, this study found that the teachers used ICMK when they support their students understanding of new mathematics concepts. For example, during the observed lesson, Mrs. Yang supported her students' development of the basic concept of how to count two-digit numbers. Mrs. Yang explained how to count two-digit-numbers by making groups of tens with straws. After explaining to the class, Mrs. Yang gave straws to her students to count. The students started to count the number of straws. Suddenly, Mrs. Yang stopped her students and asked them to look at her; then she started a mathematical conversation with them. The following is an excerpt of the conversation between Mrs. Yang and her first-grade students.

Mrs. Yang: You did a great job. I want you to help me. (Holding about 30 straws in her right hand) I'm going to count these straws. Will you please check whether I count them properly or not?

Students: Yes, ma'am.

Mrs. Yang: (Moving a straw from her right hand to her left hand one by one) One, two... seventeen. (Putting down all straws on the table and pointing to the window) Oh, what's that? Did you see it? Something passed by!

Students: There was nothing. No, we didn't see anything.

Mrs. Yang: Oh, my God! I just forgot how many straws I counted! Let's count again. One, two ...fifteen. (Putting down all straws on the table and pointing to the floor). Oh, I found my pencil here! Oh, no ... I forgot how many straws I counted again!

Students: (sigh)

Mrs. Yang: I have to count again, but I'm worried that I will forget the number again. Do you have any idea about how I can count and remember the number of straws?

(After about 5 minutes of discussion, one student said the following):

JinHo: I think you need to group the straws by ten. Then, you can simply count all the numbers of straws by counting how many groups of ten you have.

(Mrs. Jang counted the number of straws as JinHo had suggested. Mr. Yang put down a group of ten straws on the table.)

Mrs. Yang: OK, there are two groups of ten and eight straws. How can we express the total number of straws?

Students: It's 28.

Mrs. Yang: (Writing 2 on the chalkboard) there are two groups of 10, (Writing 8 on the chalkboard) and there are eight units.

(After Mrs. Yang counted, she let the students count their own straws again.)

Mrs. Yang led the conversation in order for students to find why we need to count by grouping. During the third interview, Mrs. Yang clarified her intention about why she had a conversation with students, although she had not planned it as part of her lesson plans, stating:

When I planned a lesson, I assumed that my students could count straws by using groups of 10. For example, I expected my students would say that there is one group of ten and two units, thus there are twelve straws. Students should recognize why there are needs for groups and units in order to understand the basic concept of the base-ten system. However, when I observed my students counting the straws, I noticed that most of my students just counted from one to twelve without grouping, although I already had explained how to count by using grouping. I thought that it might be natural for students. There is no reason that they could count to 12 without making groups of 10. Therefore, I created a situation in which my students needed to count numbers with grouping. I expected that my students understood the basic concepts of the base-ten system and place value as well as the need for grouping from the activity.

Analysis of data demonstrates Mrs. Yang's in-depth understanding of the concept of place value. Based on her rich knowledge of the basic concept of base-10 system and place value, Mrs. Yang provided her students an opportunity to understand the Arabic numeral system. Mrs. Yang counted numbers by using a group of 10 to show the basic

concept of the base-10 system. After that, Mrs. Yang mentioned the numbers of both groups and units when she wrote the total number on the chalkboard. Figure 7.5 demonstrates Mrs. Yang's IMCK regarding the basic concepts of the base-ten system and place value.

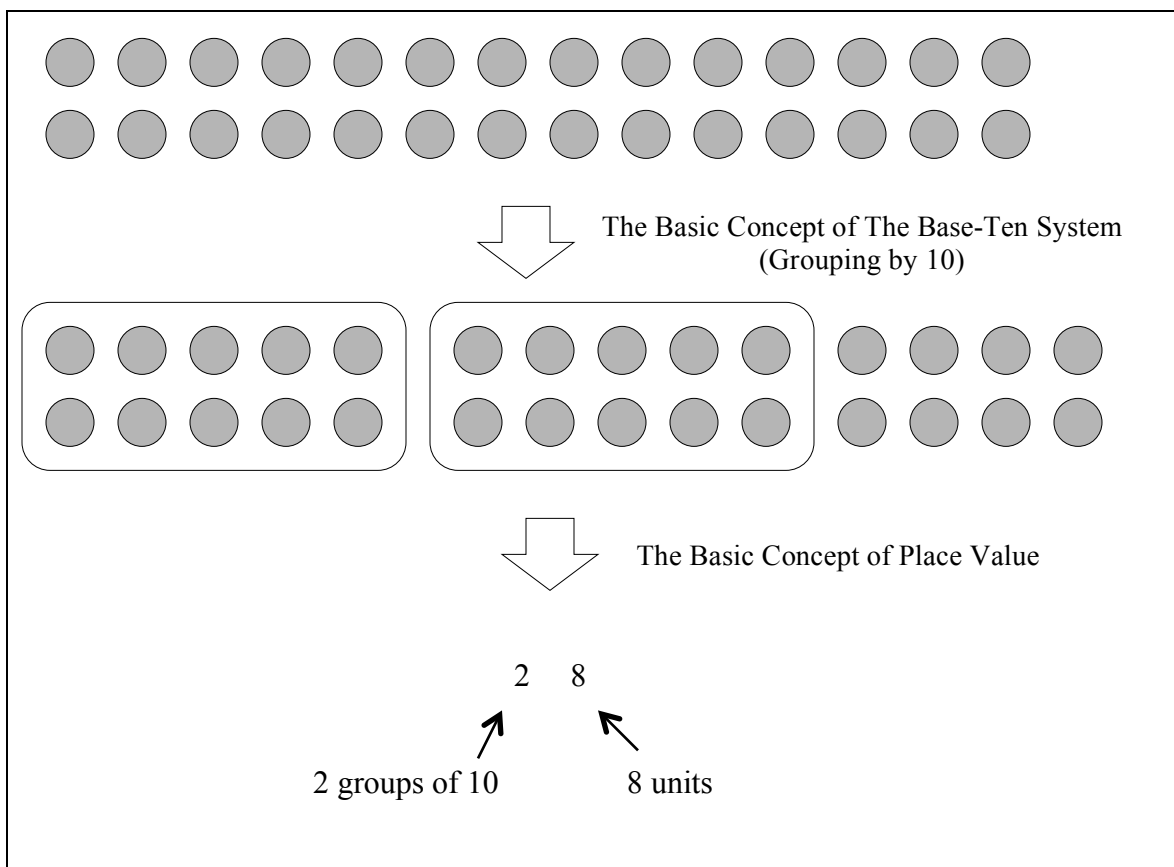

Figure 7.5. Mrs. Yang's IMCK regarding the Basic Concepts of the Base-Ten System and Place Value

This study also found that the teachers used EMCK when they explained mathematics concepts to students. All teachers in this study started the lesson by reviewing the previous lesson and ended with announcement about the next lesson. Also, the teachers tried to build connections among mathematics concepts that are covered in the textbook. The teachers' attempts to make a connection among mathematics topics and concepts also might be examples of EMCK. Furthermore, the teachers made connections

among mathematics concepts that are from different grades according to the National Mathematics Curriculum. For example, Mrs. Yoon used the relationship among the concepts of centimeter (*cm*), millimeter (*mm*) and the base-ten system when she taught the basic concept of millimeter (*mm*) to her third-grade students. According to the National Mathematics Curriculum presented in Chapter 4, students are supposed to learn the basic concept of the base-ten system in their first grade, centimeter (*cm*) in their second grade, and millimeter (*mm*) in their third grade. During the observed classroom lesson, Mrs. Yoon gave her students transparent rulers that have only the gradation of centimeter (*cm*). Mrs. Yoon required her students to measure the thickness of a textbook. The students could not measure accurately because their ruler only showed the measure for centimeter (*cm*). The following from the observed lesson demonstrates the conversation between Mrs. Yoon and the students and how Mrs. Yoon applied her EMCK during her lesson.

Mrs. Yoon: Can you measure the thickness of the textbook accurately?

Students: No.

Mrs. Yoon: Can you tell me why you couldn't measure correctly? TaeHoon, can you explain?

TaeHoon: The ruler only has marks of cm, but the thickness of the textbook is somewhere between the marks of cm. It was close to 2 centimeters (*cm*), but it was not exactly 2 centimeters (*cm*).

Mrs. Yoon: OK. Then, how can we measure the thickness of the textbook? Do you have any idea? NaYoung?

NaYoung: We need a ruler that has smaller marks than centimeter (*cm*).

Mrs. Yoon: JunHo?

JunHo: (Showing his own ruler, which has marks for both centimeters and millimeters) I can measure it with my own ruler.

Mrs. Yoon: Yes, but what if we only have this ruler? BongSeok?

BongSeok: We can use this ruler if we draw smaller marks on it.

Mrs. Yoon: Great. Now then, let's make smaller marks than centimeter (*cm*). How many marks do you want to draw that are the same as a cm? WonJae?

WonJae: I want to draw 10 marks for one centimeter (*cm*).

Mrs. Yoon: Could you explain why you want to draw 10 marks?

WonJae: Because 1 centimeter (*cm*) is equal to 10 millimeter (*mm*).

Mrs. Yoon: Then, why did people decide 1 centimeter (*cm*) is equal to 10 millimeters (*mm*)?

Students: (Silence)

Mrs. Yoon: Can you remember what the meaning of 20 is? HyunMi?

HyunMi: There are two groups of 10.

Mrs. Yoon: Great. When people decided the unit of length, they considered the number system. So they decided that 1 centimeter (*cm*) represents 1 group of 10 millimeters (*mm*) because it is easy to calculate. One centimeter (*cm*) is equal to 10 millimeter (*mm*), right? Then, is 6 centimeters (*cm*) equal to what millimeters (*mm*)?

Students: 60 millimeters (*mm*).

Mrs. Yoon: Great. Let's assume that 1 centimeter (*cm*) is equal to 12 millimeters (*mm*). Then, what are 6 centimeters (*cm*) equal to in mm?

Students: (some students calculated in their notebook) 72 millimeters (*mm*).

Mrs. Yoon: Which is easier to calculate?

Students: The previous one, when 1 centimeter (*cm*) is equal to 10 millimeters (*mm*).

Mrs. Yoon: Yes, that's why people divide 1 centimeter (*cm*) into 10 marks and named one mark as 1 millimeter (*mm*).

(After the conversation, Mrs. Yoon let students measure the thickness of the textbook with a ruler that has both cm and mm marks.)

The topic of the observed lesson was the concept of millimeter (*mm*). However, Mrs. Yoon's discussion was about the relationship among millimeter (*mm*), centimeter (*cm*), and the ten-base number system based on her EMCK. From the third interview, Mrs. Yoon clarified why she presented the relationship among mathematics concepts during the classroom conversation, explaining:

Today, I had to teach the basic concept of millimeter (*mm*). Most of my students already knew that 1 centimeter (*cm*) is equal to 10 millimeter (*mm*), as they had learned it from their private institutions. Students may simply memorize the fact that 1 centimeter (*cm*) is equal to 10 millimeter (*mm*). But I believe that the most important thing is for them to understand is that we used the basic concepts of the ten-base number system when we developed the meter system. I want my students to notice the ten-base number system in the relationship between centimeter (*cm*) and millimeter (*mm*). Thus, I focused on the relationships among centimeter (*cm*), millimeter (*mm*) and the base-ten number system.

As illustrated, Mrs. Yoon used EMCK regarding the relationship between the metric system and the base-ten system. Mrs. Yoon has understandings about base-ten number

system as well as metric system and knows how to connect them efficiently in order to explain the concept of millimeter (*mm*). With her EMCK, the teacher was able to provide an in-depth explanation that included appropriate mathematics activities about the basic concept of *mm* and the relationship between *cm* and *mm* to her students during the lesson.

The teachers in this study used both ICMK and EMCK when they corrected students' mathematical misconceptions in the mathematics classroom. Although every teacher's case is not presented, 8 of 11 teachers used their FCMK when they corrected students' mistakes as shown in Mrs. Park's case. Mrs. Park used both ICMK and EMCK to correct students' misconceptions during the lesson. Mrs. Park's sixth-grade mathematics lesson was about the concept of a cylinder. During the observed lesson, Mrs. Park asked her students to make a model of a cylinder. All the students made a model using a planar figure of a cylinder from the textbook. One student made an inappropriate model as shown in Figure 7.6.

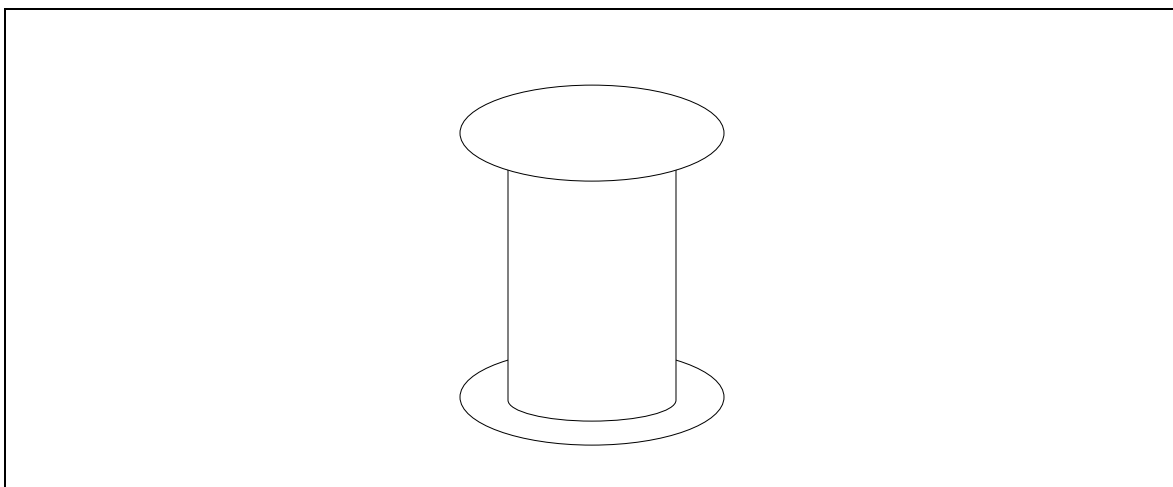

Figure 7.6. A Student's Inappropriate Model of a Cylinder

Mrs. Park showed the model to the other students and started a discussion with the students as follows. The following excerpt from the observed lesson demonstrates Mrs. Park's use of her FCMK during mathematics instruction.

Mrs. Park: Do you think this is a cylinder?

Students: No.

Mrs. Park: Could you please explain why? JangHo?

JangHo: Uh ... there are parts with the faces sticking out. A cylinder shouldn't have those parts.

Mrs. Park: Great. But, why do you think a cylinder should not have these parts? Let's read the definition of a cylinder from the textbook.

Students: A cylinder is a figure that has two congruent and parallel bases.

Mrs. Park: This model also has two congruent and parallel bases, right? Then, we can say that this model is also a cylinder, right? SuJin?

SuJin: Well ... but people do not say that it is a cylinder. I think ... people say that only this is a cylinder (showing her own model).

Mrs. Park: I see. Then, it seems like the definition of a cylinder needs to include more information. What do you want to add? JongHak?

JongHak: There are no parts sticking out?

Mrs. Park: Good. HyunJin?

HyunJin: A cylinder has two edges.

Mrs. Park: Great. Then, how many edges are in this model?

Students: Four...?

Mrs. Park: What is an edge? BoKyoung?

BoKyoung: The line where two surfaces meet.

Mrs. Park: Then, this model has also two edges, right? Here, there are only two lines where two surfaces meet. The other two lines are only made by one surface.

SuYoen?

SuYoen: So I think the two lines are not edges. I think they are sides because they have just one face.

Mrs. Park: Great. Then how about these two lines where two surfaces meet? Do you think these are edges?

Students: Yes/ No (students' murmuring with diverse answers).

JaeHyuk: I think ... the definition of the edge is wrong. Maybe ... we can say that the edge is the line where each side of two surfaces meets.

During the third interview, Mrs. Park clarified her intention on why she had concentrated on developing the definition of a cylinder with students during the lesson as follows:

Most of my students already have learned about the definition of a cylinder from their private institution before today's lesson. But as you saw during the lesson, the concepts of a cylinder might not be simple. Actually, my students should understand the concept of *enclosed* to define a cylinder, but they do not learn about it at this level. Anyway, I just wanted my students to understand diverse concepts related to a cylinder during the conversation. That's why I chose an inappropriate model of a cylinder for discussion. I could simply show the proper model and make my students memorize the definition of the cylinder. But I believe that those discussions would be helpful in their development of a strong conceptual understanding of a cylinder. Also, it would be helpful to firm up their mathematics concepts they already had.

Analysis of the observation of the lesson and the subsequent interview revealed that Mrs. Park's discussion with her students regarding the definition of a cylinder is based on her

rich knowledge about the basic concept of a cylinder and related mathematics concepts such as edges or *enclosed*. Mrs. Park's ICMK regarding the basic concept of a cylinder provides a solid foundation for leading a discussion during the lesson. In addition, Mrs. Park included the basic concepts of edges or *enclosed* that related to the concepts of a cylinder based on her EMCK during the discussion.

The findings presented in the section suggest that FCMK may include embryologic origins of the mathematics concepts. For example, Mrs. Yang helped students develop an understanding of the basic concepts of the base-ten system by assisting students in their development of why they needed to count by making groups of 10 rather than just modeling with a manipulative such as base-ten blocks. The number systems have been developed to represent large numbers effectively (Rudman, 2007). During the observed lesson, Mrs. Yang created a situation that needed the basic concepts of grouping. Based on this activity, students might start to understand why we need the base-ten system as well as the basic concept behind it. Mrs. Yoon also attempted to support students' understanding of the basic principle of metric system rather than just showing that 1 centimeter (cm) is equal to 10 millimeters (mm). The metric system was determined by adopting the base-10 system in order to use a single scale for all measurements (Sarton, 1935). Mrs. Yoon supported the students' understanding of why 1 centimeter (*cm*) includes 10 millimeter (*mm*) by asking questions rather than having students memorize that 1cm is equal to 10mm. For these teachers, to understand mathematics concepts mean more than knowing the concepts well; the teachers' knowledge of mathematics concepts includes how the mathematics concepts were developed and how to apply historical information of mathematics concepts during their

mathematics instruction. Thus, as discussed in a previous section, there needs to be further investigation into the relationship between teachers' understanding of mathematics concepts and their embryologic origins.

Using FMCK When Assessing Students' Work

The teachers in this study used their FMCK when they assessed a student's work. In the second interview, the teachers were asked to examine work completed by students in fourth grade that involved multiplying large numbers (See Appendix C.) Mrs. Lee assessed the student's mathematical status based on her judgment on the student's work, stating:

Well, it seems like this student does not know the basic principle of operation and place value. Well ... I would help the student understand the place-value system with base-ten blocks first. For me, it seems like the student does not understand the numeric information in each number. And I'm going to tell the student about how to write numbers in proper positions in this calculation. Well ... I think I need base-ten blocks here, too. I believe that the student has to understand why there are blank spaces. So I'm going to show the process of calculating and the omission of zeros to the student. And I'm going to make the student solve similar problems by him or herself.

Interviewer: The student solved a multiplication problem. Why did you point out the student's lack of understanding of place value?

Mrs. Lee: Actually, the student has no problem with solving multiplication problems.

Probably, I believe that ... she just memorized the multiplication table. That's how she solved the multiplication problem. However, when she wrote down the

answers for multiplication, she didn't do well in placing numbers in the right positions. This might show that she had a problem understanding place value. Mathematics topics are connected to each other. If a student does not understand one thing, this will probably cause another problem when learning new mathematics topics.

Interviewer: If so, what are you going to do based on your assessment of the student's work?

Mrs. Lee: Well, I need to check her understanding on the concept of place value with diverse manipulatives such as base-ten blocks. Also, I will assess her understanding on the concept of multiplication. As I said before, there is a great chance that she memorized the multiplication table. I believe that's how she solved the problem. Thus, I need to check it and provide the right feedback according to the student's mathematical status.

From the interview, Mrs. Lee focused on the related concepts such as place values or understanding of numeric information in each number based on her FMCK rather than pointing out the student's calculation mistakes with multiplication. Mr. Cho also provided a similar judgment about the student's work, explaining:

It seems like that the students do not have the basic concepts of place value. Also, she does not know the basic concepts of algorithms for multiplication with large numbers. I think that the students should know that 654 represent $600 + 50 + 4$, first. Then, they have to understand that zero does not need to be recorded while they are calculating.

Interviewer: The student solved the multiplication problem. Why did you point out the student's lack of understanding of place value?

Mr. Cho: Well ... since it provides the basis for multiplication. If teachers just focused on students' current statuses, they may not assess students' mathematical abilities properly. For example, if I let the student only know how zero was abridged in this problem, the student may have similar difficulty when solving division problems. We, teachers, should help students understand the concepts and apply their understandings to new mathematics problems. Just to teach algorithms that students may use without mathematical understanding will not be helpful in the end.

Interviewer: So you check related mathematics concepts when you assess students' work?

Mr. Cho: Sure. I try to focus on how my students understand the mathematics concepts and the relationship among them when they solve mathematics problems rather than the algorithms themselves.

Mr. Cho pointed out the problem of the student's problem-solving process based on his FMCK. Mr. Cho made a connection between addition and place-value system in order to assess the student's work. The other nine teachers also reacted in a similar way to that of Mrs. Lee and Mr. Cho. As shown above, FCMK affects the way teachers diagnose students' mathematics abilities or background and how teachers approach students to improve their understanding of mathematics concepts. The teachers did not pay attention to whether the student got the correct answer or not. Rather, the teachers used their FMCK to understand the student's mathematical background and to consider what approach or activity may help students solve mathematics problems.

Interpretive Summary

This study classifies teachers' understanding of mathematics concepts and representations of them during mathematics instruction as Fundamental Mathematics Conceptual Knowledge (FMCK). Based on Skemp's (1989) assumption that mathematics concepts indicate both the mental representations that are derived from sensory experiences and the relationship among the representations, FMCK is divided into two subcategories: Intrinsic Mathematics Conceptual Knowledge (IMCK) and Extrinsic Mathematics Conceptual Knowledge (EMCK).

In attempting to analyze FMCK during an actual instructional process with diverse types of data, I found that FMCK is the fundamental category of a South Korean elementary teacher's knowledge for teaching mathematics and FMCK is integrated into elementary teachers' whole process of instruction. The teachers used both IMCK and EMCK when they were planning mathematics lessons by clarifying both the mathematics concept itself and the relationship among mathematical concepts as well as by extracting meaningful implications from them. The teachers used their FMCK during conversations with students during their mathematics lessons. From the analysis of observed lessons, this study also found that FCMK might include embryologic origins of mathematics concepts. In addition, FCMK affects the way teachers diagnose students' mathematics abilities or backgrounds and develop approaches or activities that may help improve students' understanding of mathematics concepts.

Ball, Thames, and Phelps (2008) argue that the teachers' knowledge of mathematics content might differ from mathematicians' knowledge. Teachers' knowledge of mathematics content should comprise knowledge regarding how the

mathematics content might be transformed into ways that will help students' understanding of mathematics concepts (Ball, et al., 2008). This study revealed that teachers should have in-depth knowledge of mathematics concepts in order to transform them according to students' mathematical levels. However, teachers' knowledge of mathematics concepts may not indicate just understanding mathematics concepts; it may also include knowing about appropriate models or activities that are effective for explaining mathematics concepts to students. As Ma (1999) asserted, in-depth understanding of mathematics concepts help teachers explain to students mathematical connections, multiple perspectives, and fundamental ideas of concepts.

The findings of this chapter are in keeping with the assertion of previous studies that elementary teachers should know how to provide opportunities to their students for developing mathematics concepts. However, previous studies put more emphasis on how to connect mathematics concepts, which for this study is defined as EMCK. For example, Ma (1999) asserted that teachers must have a "profound understanding of fundamental mathematics" (p.107), which represents a composite network of mathematics topics. According to Ma (1999), teachers who have a profound understanding of fundamental mathematics may present the relationship between mathematical concepts and its procedures to their students effectively by recognizing diverse aspects and related mathematical ideas of one mathematics concept. For instance, teachers need to know the mathematics concepts of place value to teach a subtraction operation that needs regrouping. Kilpatrick, Swafford, and Findell (2001) also stated that elementary teachers should use their understanding of abstract mathematics concepts to support their students when making connections among mathematics concepts. However, as shown in this

chapter, teachers' IMCK is also a significant factor in designing mathematics activities that provide mathematical experience that helps students develop mathematics concepts. Therefore, the teachers need to have a strong knowledge base of mathematics concepts and know how to connect them to one another.

From Chapter 5 through 7, I presented one of the major categories of South Korean elementary teachers' knowledge for teaching mathematics: Mathematics Curriculum Knowledge, Mathematics Learner Knowledge, and Fundamental Mathematics Conceptual Knowledge. These three categories of knowledge were identified as significant elements of mathematics instruction. The following chapter focuses on the last two major categories of South Korean elementary teachers' knowledge for teaching mathematics with a discussion about the relationship among the categories of knowledge.

CHAPTER 8

Knowledge for Teaching Mathematics Category IV: Mathematics Pedagogical Content Knowledge (MPCK) and Mathematics Pedagogical Procedural Knowledge (MPPK)

Chapters 4 through Chapter 7 of this study focused on three categories of South Korean elementary teachers' knowledge for teaching mathematics: Mathematics Curriculum Knowledge, Mathematics Learner Knowledge, and Fundamental Mathematics Concepts Knowledge. Analysis of data revealed that these categories seemed to influence the teachers' mathematics instruction. However, there are still questions regarding the relationship among these categories and the substance of Pedagogical Content Knowledge.

The first question focused on whether there is a clear distinction between these categories. From the results of the analysis, I found that the teachers used their Mathematics Curriculum Knowledge and Mathematics Learner Knowledge when they analyzed students' mathematics backgrounds. The teachers also used their Fundamental Mathematics Concepts Knowledge when they considered the range of concepts outlined in the National Mathematics Curriculum (e.g., place-value concepts across various elementary grades) that they planned to cover in their lesson plans. This may illustrate that it might not be feasible to explain one category of teachers' knowledge for teaching mathematics without mentioning the other categories.

The second question focused on what the differences are between Pedagogical Content Knowledge and other categories of teachers' knowledge for teaching mathematics. Because Shulman (1987) defines Pedagogical Content Knowledge as a special form of teachers' professional understanding, which provides a special amalgam

of content and pedagogy, the common assumption regarding teachers' knowledge is that there is a difference between what teachers know about the subject and what teachers know regarding how to teach the subject. However, the results of analysis from Chapter 4 to 7 illustrate that the teachers use the other categories of knowledge for teaching mathematics during instruction. Then, can we say that these three categories are also Pedagogical Content Knowledge?

This chapter will focus on the fourth and fifth categories of knowledge for teaching mathematics: *Mathematics Pedagogical Content Knowledge* and *Mathematics Pedagogical Procedural Knowledge*. Unlike the other chapters, this chapter will cover two types of categories of knowledge for teaching mathematics due to their inseparable relationship. In addition, the structure of this chapter is notably different from the structure of the preceding ones because both Mathematics Pedagogical Content Knowledge and Mathematics Pedagogical Procedural Knowledge emerged from the relationship among the categories of knowledge for teaching mathematics. Thus, this chapter begins with the common characteristics of the categories to find the relationship among them, and then the definition of Mathematics Pedagogical Content Knowledge and Mathematics Pedagogical Procedural Knowledge is addressed. The following section presents the model of the structure of South Korean elementary teachers' of knowledge for teaching mathematics based on the discussions regarding knowledge categories. The last section provides an interpretive summary of this chapter.

The Nature of Categories of Knowledge for Teaching Mathematics

Thus far, the discussions in the literature about the characteristics of knowledge for teaching mathematics provide limited information about the dynamic features of

teachers' knowledge (Marks, 1990; Eisenhart, Borko, Underhill, Brown, Jones, & Agard, 2012; Meredith, 1995; Stones, 1992). Also, the perception that emerged from the literature is that the relationship among the categories is simply a transmission model such as inclusion relations (e.g., Shulman, 1987) or a model that uses vague terms for describing the relationship such as *combines* without explaining the process of how different types of knowledge are integrated (Ball, Thames, and Phelps, 2007, p.401). Thus, this study focuses on the nature of the categories of teachers' knowledge for teaching mathematics first to reveal the relationship among categories. To understand the essence of how teachers' knowledge for teaching mathematics is constructed, it is important to reveal the relationship among the categories of teachers' knowledge; also, it may help us understand how Pedagogical Content Knowledge and Mathematical Pedagogical Procedural Knowledge emerged from the analysis.

As illustrated in the conceptual framework in Chapter 1, an assumption is that internal representations such as ideas, facts, or procedures might be connected to one another in useful ways based on assertions made in cognitive science (Hiebert & Carpenter, 1992). Although there have not been many discussions regarding the cognitive connection to teachers' knowledge, the results from Chapter 4 to Chapter 7 suggest that we need to focus on these connections to understand the characteristics of categories of teachers' knowledge for teaching mathematics. From Chapter 5, the teachers have knowledge regarding the mathematics concepts based on the National Mathematics Curriculum along with the relationships among them. The teachers also know students' characteristics related to the lessons' objectives and how to connect the characteristics to their mathematics instruction as illustrated in Chapter 6. Chapter 7's findings showed that

the teachers' have an understanding of mathematics concepts and relationships among them.

Based on the findings and according to the conceptual framework, I propose that these relationships might be structured as a network of each category of elementary teachers' knowledge for teaching mathematics. In particular, I took Hiebert and Carpenter's (1992) assertion that networks of mathematical knowledge might have a three-dimensional web-shaped structure. Based on the researchers' argument, I illustrate the model of teachers' knowledge as shown in Figure 8.1. However, it is important to note that it is possible that the shape of each individual teacher's network will be different. Although Figure 8.1 presents representative images of the network, the diagram may illustrate only part of the network due to the lack of space. Thus, the network may be expanded in all directions.

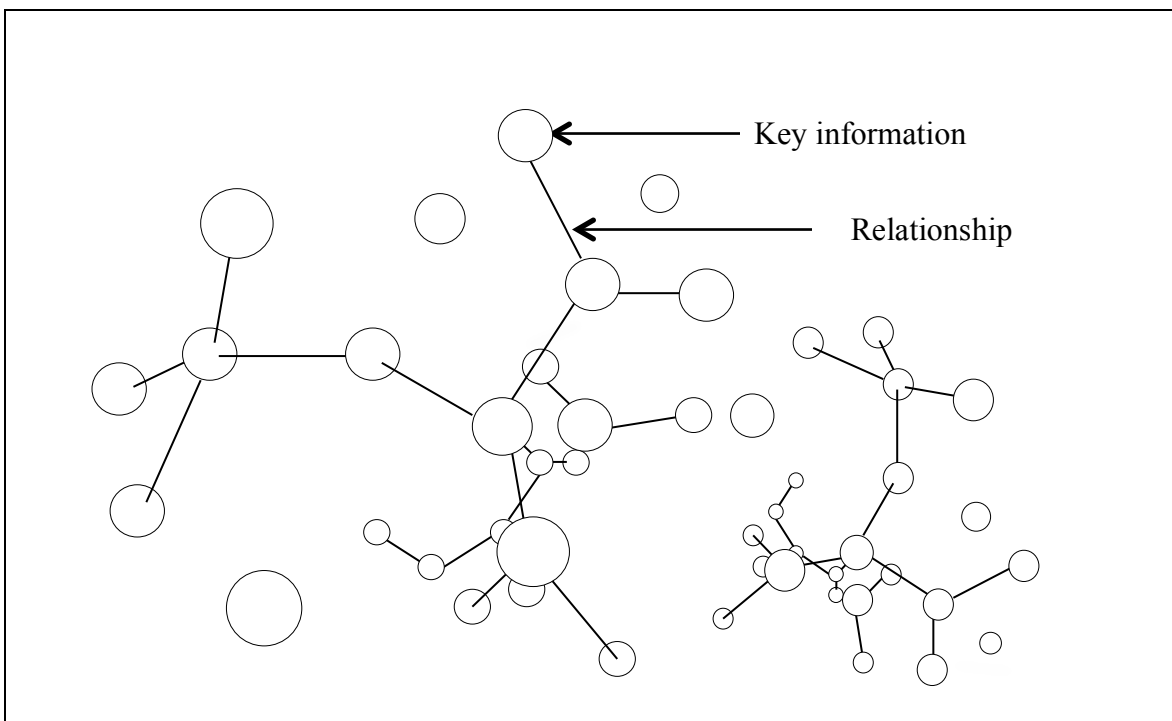

Figure 8.1. Networks of Knowledge

From Figure 8.1, the nodes are considered the key information, and the lines show the relationships among them. The definition of key information might differ according to each category. For Mathematics Curriculum Knowledge, the nodes represent the mathematics topics that a teacher is supposed to present in a class based on the National Mathematics Curriculum. However, the nodes represent diverse students' characteristics such as knowledge, skills, or attitudes for Mathematics Learner Knowledge as discussed in Chapter 6. Regarding Fundamental Mathematics Concepts Knowledge, the nodes indicate the mathematical representation of a concept.

One of the notable aspects in this figure is that some nodes in the structure are connected, whereas some nodes are independent. When nodes are independent and show no connections, they exemplify that teachers do not know the relationship between key information. Although the data from Chapter 5 to Chapter 7 may suggest that all information in each category is connected in some way, the following excerpt from the first interview with Mrs. Lee illustrates that teachers may have some knowledge that may not be connected to other knowledge. Mrs. Lee explained how she perceived the mathematics topics when she was a novice teacher, stating:

When I was a novice teacher, I just taught the mathematics topics according to the National Elementary Teacher Guidebook. I knew what I was supposed to teach for each lesson. However, I did not know the relationship between topics. After a couple of years, I realized that there were relationships among topics and even among chapters in the textbook. I also realized that it could be effective when I used these relationships in my teaching. I could review what my students learned

in their past, and I could explain the relationship between what they had learned and what they were going to learn today.

Mrs. Lee pointed out that she did not know the relationship among mathematics topics, although she had knowledge on each topic. The other 10 teachers also reported that they developed their understanding of the relationship among the categories of knowledge for teaching mathematics through their teaching experiences. This study only focused on experienced elementary teachers' knowledge for teaching mathematics. Thus, it may not be feasible in this study to discuss the change of networks according to teacher experiences. However, what is clear in this discussion is that each category of knowledge for teaching mathematics already has complicated structures and that experienced teachers know the relationship among key types information in each category. Although there needs to be future research about how the key information is connected, discussion in this section suggests that categories of knowledge may consist of key information and their connections. Thus, the relationship among categories, which will be discussed in the following section, should be understood based on these characteristics.

The Relationship Among Categories of Knowledge for Teaching Mathematics

The results of data analysis revealed that the teachers in this study have in-depth Mathematics Curriculum Knowledge, Mathematics Learner Knowledge, and Fundamental Mathematics Conceptual Knowledge as discussed in the previous chapters. The analysis process of the relationships among these categories of South Korean elementary teachers' knowledge for teaching mathematics show that the teachers used some parts of each category during mathematics instruction.

For instance, when Mrs. Kim taught the basic concept of a sketch of a rectangle parallelepiped to her fifth-grade students based on her Fundamental Mathematics Conceptual Knowledge, Mrs. Kim did not cover all mathematics concepts related to the topic. As discussed in Chapter 7, Fundamental Mathematics Conceptual Knowledge indicates teachers' in-depth knowledge of mathematics concepts and the relationships among them. Although Mrs. Kim had knowledge of diverse mathematics concepts that may relate to a sketch of a rectangle parallelepiped and the relationship among them, Mrs. Kim decided to use some parts of her knowledge. From the third interview, Mrs. Kim revealed her intention, stating:

To understand the concept of a sketch of a rectangle parallelepiped, students should have an understanding of three-dimensional figures as well as two-dimensional figures. To understand the concepts of figures, students should have an understanding of the basic concept of angles, quadrangles, or components of three-dimensional shapes. Again, to understand the concept of edges, students should have knowledge of lengths and continuous quantities. The relationships among mathematics concepts are complicated—like a spider's web. However, if I tried to cover all the concepts, the lesson would be meaningless to students. Students should focus on learning new concepts rather than reviewing what they have studied previously. So I had to determine the key concepts that relate to a sketch of a rectangle parallelepiped for today's mathematics class. Among diverse mathematics concepts, I decided to focus on the relationship between the concept of parallel lines and the concept of a sketch of a rectangle parallelepiped for today's

lesson, as the concept of parallel lines might be key to understanding the concept of a sketch of a rectangle parallelepiped.

The interview shows how Mrs. Kim presented diverse mathematics concepts that relate to the lesson topic (e.g., angles, quadrangles, or components for three-dimensional shapes). Among diverse related concepts, Mrs. Kim chose the concept of parallel lines based on her Fundamental Mathematics Conceptual Knowledge and students' mathematical backgrounds.

Another example of the teachers' selective use of their knowledge is the teachers' use of Mathematics Curriculum Knowledge. As shown in Chapter 5, diverse mathematics topics are presented in each grade according to the National Mathematics Curriculum. However, the teachers presented only parts of students' learning referred to as *the flow of learning* in their lesson plans. Figure 8.2 is an example of *the flow of learning* from Mrs. Kim's lesson plan.

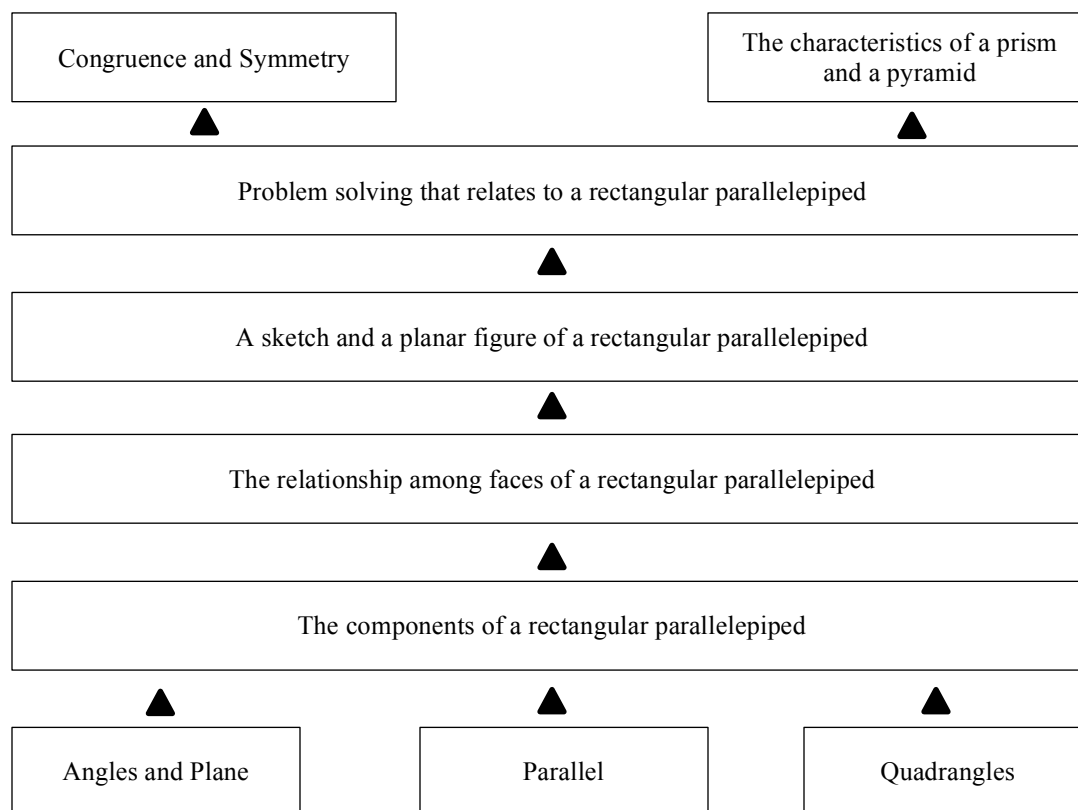

Figure 8.1. The flow of learning from Mrs. Kim's lesson plan

As shown in Figure 8.2, among diverse topics from the National Mathematics Curriculum, Mrs. Kim only presented some parts of them in her lesson plan based on her Mathematics Curriculum Knowledge. Similarly, among diverse students' mathematical backgrounds, Mrs. Kim focused on students' understanding of the basic concepts of parallel lines as illustrated in Table 8.1.

Table 8.1.

Mrs. Kim's Understating on Her Students

Results	Number of students	Percent (%)
Students do not understand the basic concept of parallel lines or cannot draw them well.	8	19.1%
Students do understand the basic concept of parallel lines or can draw them.	27	64.3%
Students do understand the basic concept of parallel lines and can draw them well.	7	16.6%

Similar to Mrs. Kim's case, the other 10 teachers also used their categories of knowledge selectively. The teachers made instructional decisions based on the range of mathematics concepts to be covered based on the National Mathematics Curriculum and on students' characteristics (See Figure 8.3).

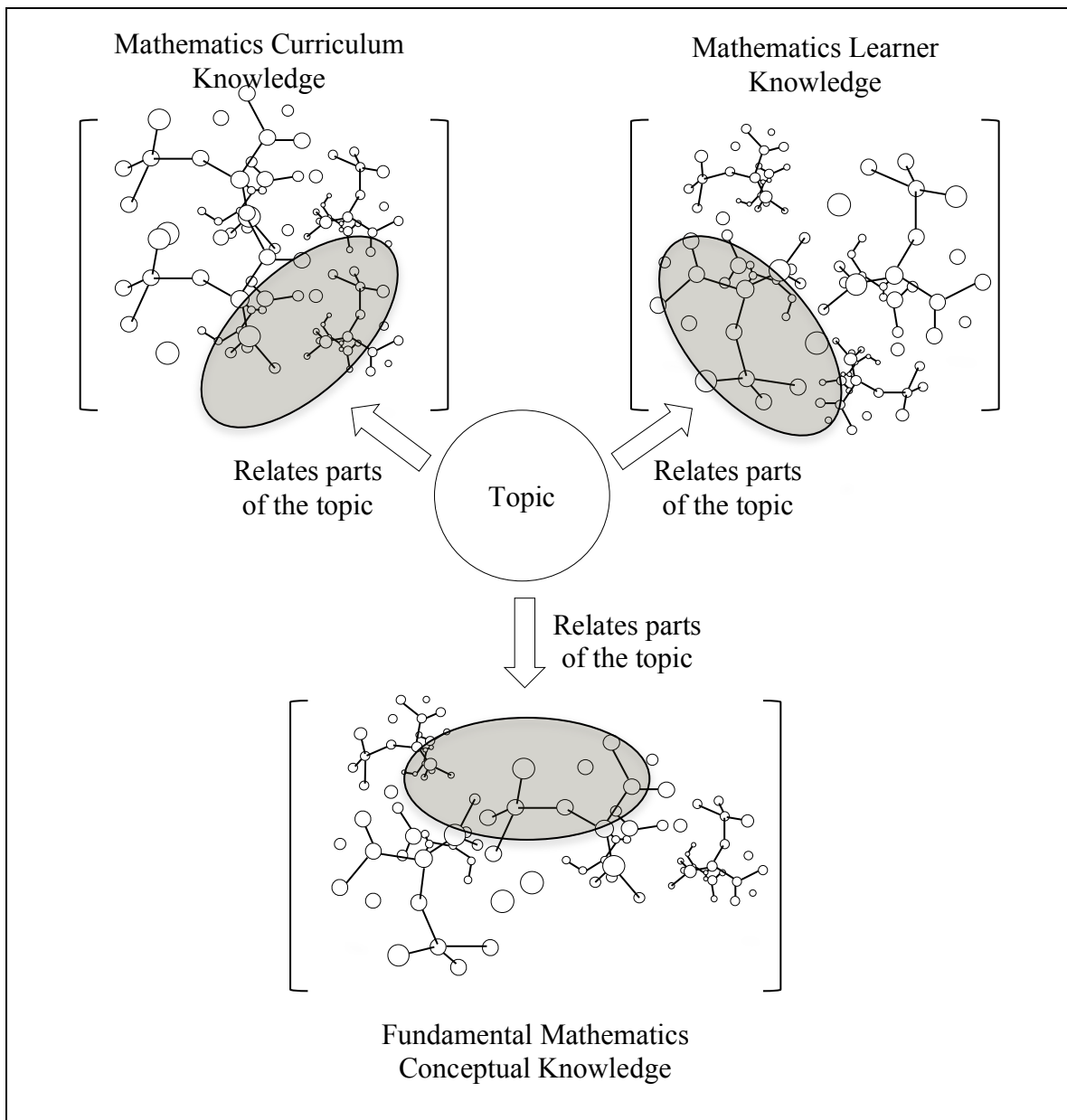

Figure 8.3. Teachers' Decisions on the Range of Each Category

However, this does not indicate that the categories of teachers' knowledge for teaching mathematics are independent of each other; furthermore, the teachers chose to use some

parts of their knowledge by considering the other categories. For example, Mrs. Kim explained which parts of her knowledge she would use in her mathematics instruction, stating:

Among diverse related mathematics concepts to today's topic, I chose key concepts based on my understanding of students' mathematical background and the students' sequence of learning according to the National Mathematics Curriculum. For example, I taught the concept of a sketch of a rectangle parallelepiped today. Among diverse related concepts such as angles, quadrangles, or components for three-dimensional shapes, I covered the relationship between the concept of parallel lines and the concept of a sketch of a rectangle parallelepiped. When I taught previous chapters regarding numbers or the other shapes, I found that my students had a decent understanding of the other related concepts such as quantities or components of two-dimensional shapes. Thus, I did not feel the need to cover those concepts in today's lesson. In addition, from the analysis of students' sequence of learning, I found that my students should have learned the concepts of parallel lines in their previous grades. I checked the curriculum because I only could use the concepts that my students had learned in their previous grades or textbook chapters to explain the lesson's new concept.

During the interview, Mrs. Kim stated that she had used her Mathematics Learner Knowledge and Mathematics Curriculum Knowledge when she determined the range of related mathematics concepts she was going to cover in her lesson. This was not unique to Mrs. Kim. As discussed in Chapter 5, the teachers used their Mathematics Curriculum Knowledge when they analyzed their students' mathematical background, which relates

to their Mathematics Learner Knowledge. In Chapter 6, findings illustrated how the teachers also focused on certain students' characteristics from teachers' Mathematics Learner Knowledge according to the topic they have to teach based on their Mathematics Curriculum Knowledge. In addition, the teachers reported that their Mathematics Curriculum Knowledge is helpful in improving their Fundamental Mathematics Content Knowledge, and Chapter 7's discussion showed that Fundamental Mathematics Content knowledge is also useful to help the teachers improve their Mathematics Learner Knowledge. In particular, analysis of the third interview demonstrated how Mrs. Choi might integrate different categories of teachers' knowledge to teach mathematics. Mrs. Choi explained how she had made a judgment when deciding to use the range of mathematic concepts, the curriculum, and students' characteristics in order to teach a specific mathematics topic, stating:

In my case, when I have to teach, I usually draw a map of mathematics concepts that relate to the topic. And I try to find the related mathematics concepts that my students already have learned based on the analysis of the curriculum. Oh, I try to find the flow of the curriculum that overlaps with my map of mathematics concepts. And I try to identify what my students knew exactly by using diagnostic assessments. When I developed the test, I chose key mathematics concepts from the map and the curriculum.

Analysis of the data indicates that Mrs. Choi considered the related mathematics concepts first based on her Fundamental Mathematics Conceptual Knowledge and tried to find related mathematics concepts or topics from the National Mathematics Curriculum with her Mathematics Curriculum Knowledge. With the results of analysis of the National

Mathematics Curriculum, Mrs. Choi developed a diagnostic assessment in order to understand her students' mathematical backgrounds, which relate to her Mathematics Learner Knowledge. The other 10 teachers also reported that they connect information from different categories by providing ground for selection process to one another. When the teachers determine the range of mathematics concepts they are going to cover during the lesson, they also consider their students' mathematics understanding of concepts from their Mathematics Learner Knowledge. Likewise, when teachers analyze students' understanding, they used their Fundamental Mathematics Conceptual Knowledge.

The teachers use some parts of their categories of knowledge by considering the other categories. Thus, the connection among categories might be created by the teachers' objectives for the mathematics lesson. From Figure 8.4, the connections between categories are denoted as dashes to distinguish them from the conceptual connections of a category. This study named the ranges where the connections are formed as *intersection*.

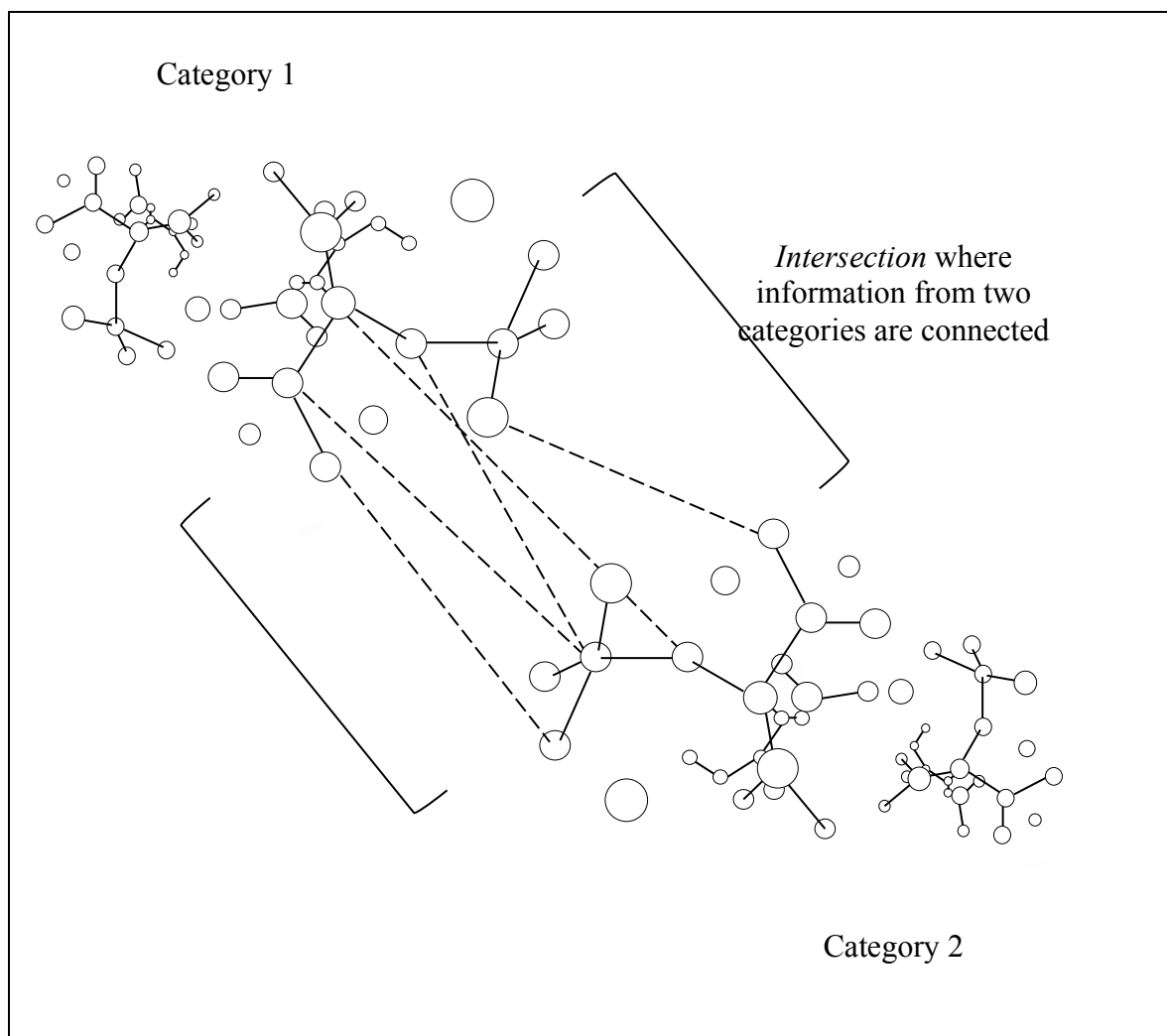

Figure 8.4. The Definition of Intersection from the Connections between Categories

Thus, when teachers select some parts of their Fundamental Mathematics Content Knowledge to teach a specific mathematics concept, the range of curriculum or students' characteristics might be located in the intersection between two types of categories of knowledge for teaching mathematics, as presented in Figure 8.5.

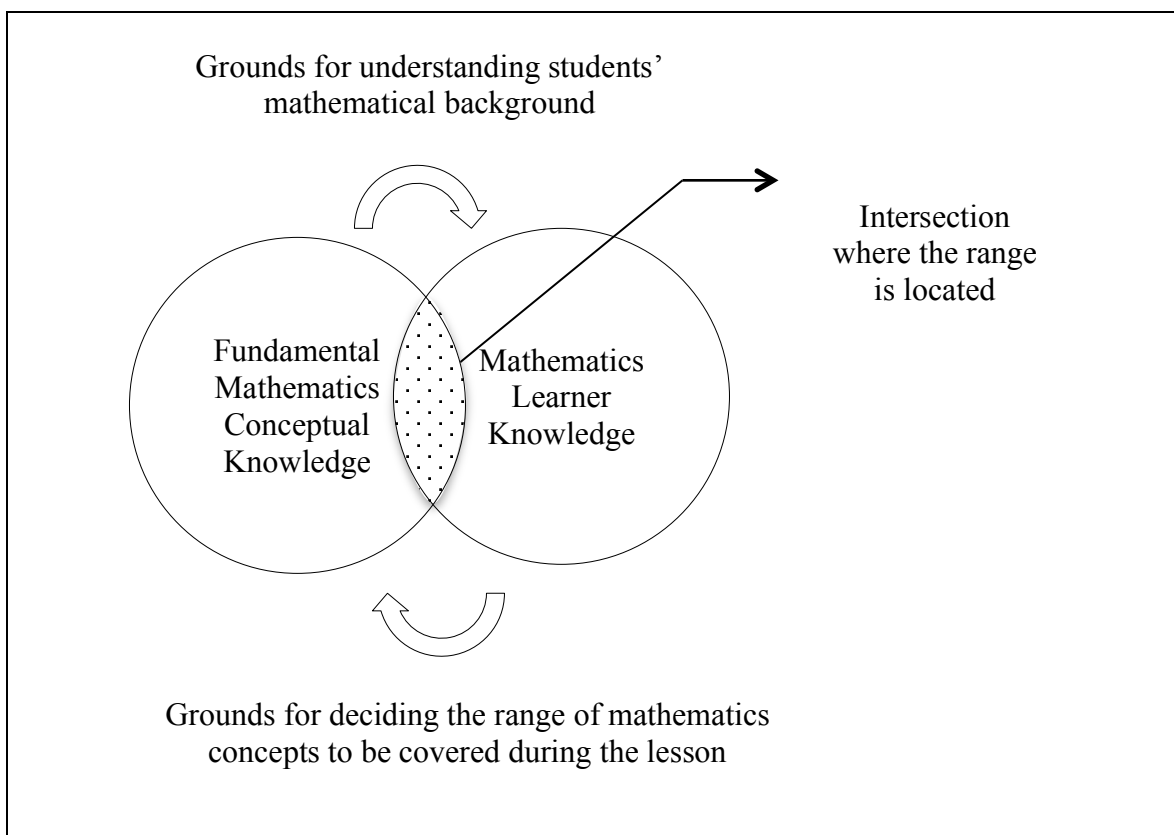

Figure 8.5. Intersection Between Two Types of Categories of Knowledge I

For example, when Mr. Ki taught the basic concept of addition to his second-grade students, he considered related mathematics concepts such as various representations of addition or quantities before developing the lesson plan. While Mr. Ki was developing the lesson plan, he considered how the key mathematics concepts should be presented to his students based on their mathematics backgrounds; when Mr. Ki chose an example of addition of continuous quantities, he used addition related to telling time, as his students had just learned about telling time in their previous grade.

Similarly, when the teachers decide on the range of curriculum from their Mathematics Curriculum Knowledge, their Fundamental Mathematics Conceptual Knowledge provides criteria regarding the range of the curriculum and vice versa as presented in Figure 8.6. As discussed in Chapters 5 and 7, the teachers did not only focus

on a mathematics topic that they must teach during class instruction. Rather, the teachers considered related mathematics concepts and investigated the curriculum based on their understanding of mathematics concepts. Therefore, based on the mathematics concepts and the related curriculum, the teachers decided on the range of the mathematics concepts that they were going to cover during the lesson.

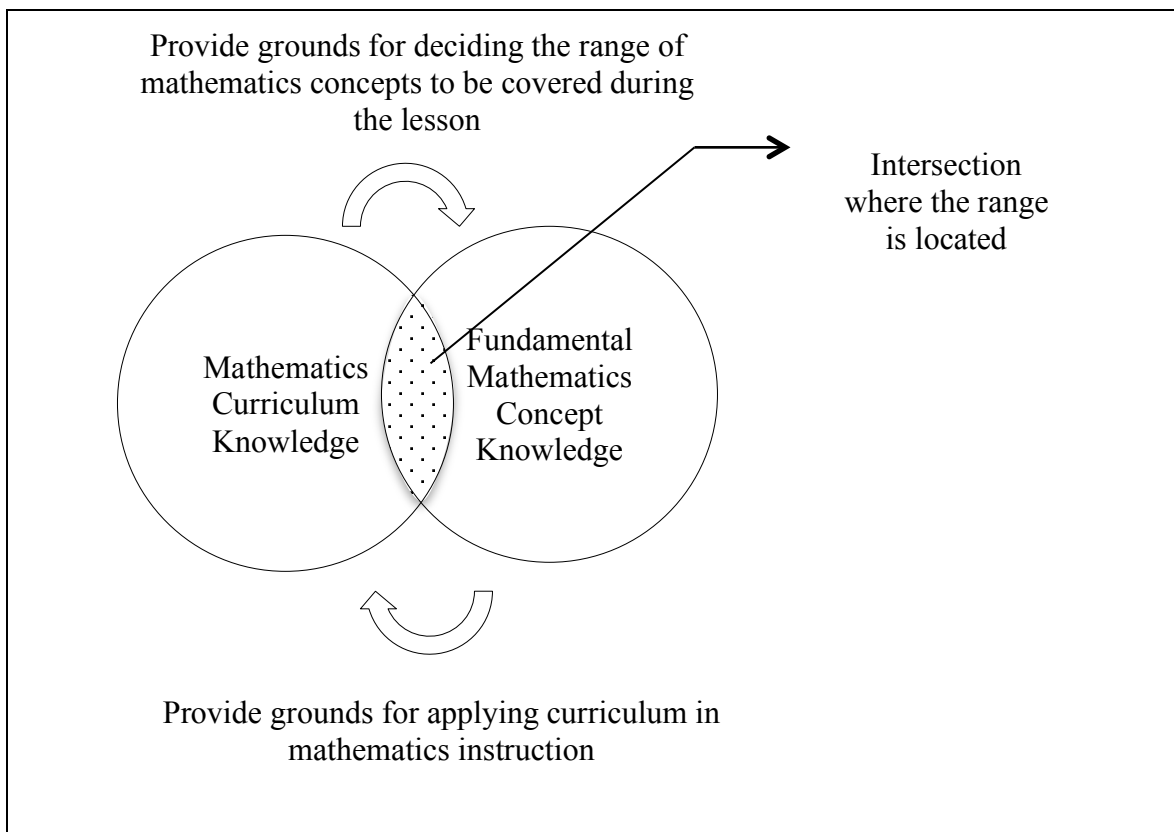

Figure 8.6. Intersection Between Two Types of Categories of Knowledge II

In Chapters 5 and 6, the teachers applied their Mathematics Curriculum Knowledge to understand their students' academic history regarding mathematics learning. The teachers also used their Mathematics Learner Knowledge to find effective ways to develop lesson plans based on the curriculum. Thus, the relationship between Mathematics Curriculum Knowledge and Mathematics Learner Knowledge could be represented as illustrated in Figure 8.7.

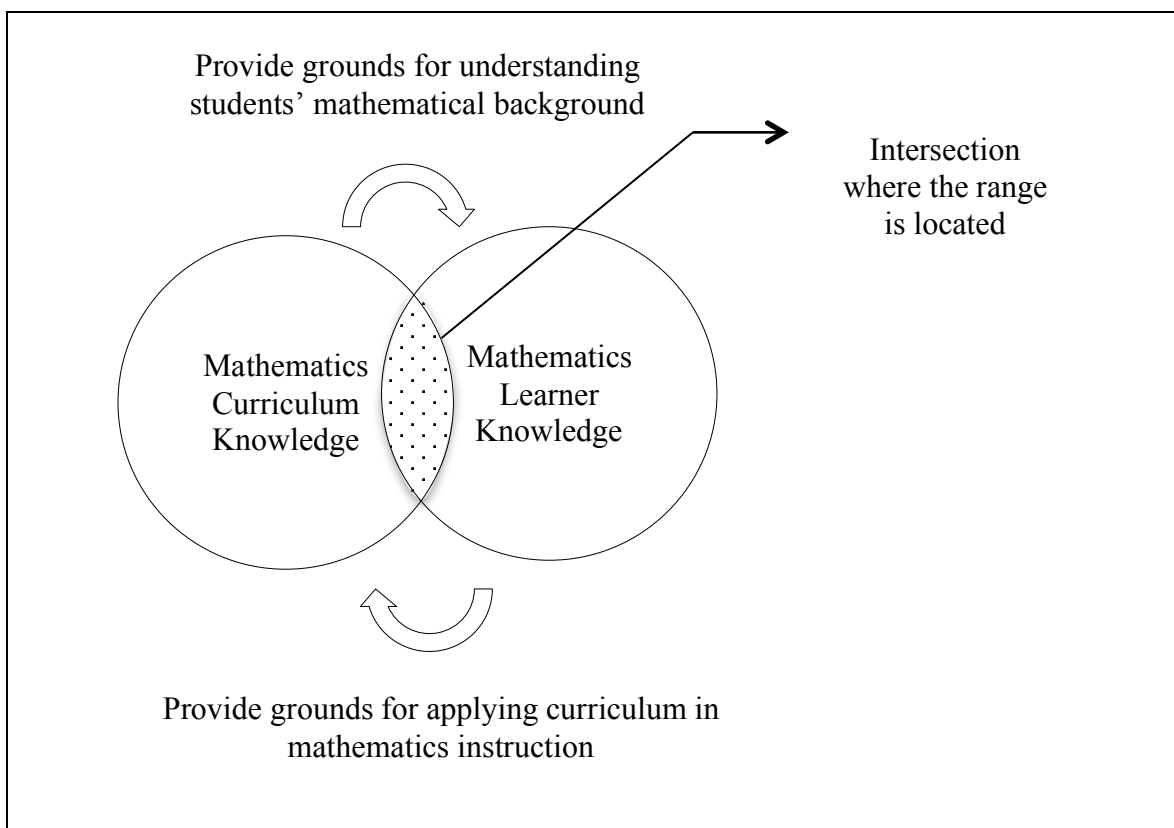

Figure 8.7. Intersection Between Two Types of Categories of Knowledge III

Ball, Thames, and Phelps (2009) asserted that there is mathematical knowledge and skills unique to teaching, which emerged by combining two types of knowledge. For example, *knowledge of content and student* (p. 401) is knowledge that combines knowing about students and knowing about mathematics. Ball, et al. (2008) argued that this knowledge requires an interaction between a particular mathematical understanding and familiarity with students. Although Ball et al. (2008) pointed out the significance of combining different types of knowledge; there is a lack of explanation about how the two types of knowledge are integrated. The results of the analysis demonstrate that the teachers use the other categories of knowledge as judgments to determine which parts of their knowledge should be used to teach mathematics. Thus, it might be feasible to see

how the relationships between two categories are connected (i.e., linked) rather than combined (i.e., merged).

This section focused on answering the first question by revealing the relationship among categories of teachers' knowledge to teach mathematics. However, there are still the remaining questions about the connections between categories of knowledge and Pedagogical Content Knowledge. The following section presents a discussion on the substance of Pedagogical Content Knowledge for teaching mathematics based on the relationship among categories.

Mathematics Pedagogical Content Knowledge

Since Shulman (1987) defined Pedagogical Content Knowledge as special form of professional understanding that provides a special amalgam of content and pedagogy, there have been several meanings put forward by different researchers that define Pedagogical Content Knowledge (PCK) for teaching mathematics. From my examination of these definitions, several common assumptions regarding PCK emerged: PCK is a superordinate concept that includes some subcategories of knowledge (e.g., Shulman, 1987; An, Kulm, & Wu, 2004; Ball, Thames, & Phelps, 2009), and the teachers can support their students' understanding of mathematics concepts with Pedagogical Content Knowledge (e.g., Parker & Heywood, 2000; An, Kulm, & Wu, 2004).

If we assume that PCK is the sum of the other categories, then each category of teachers' knowledge would decide their depth of PCK. However, the relationship among the categories that were discussed in the previous section raised the question about the assumption that PCK comprises the other categories. The teachers used some portions of their categories of knowledge selectively. In addition, when the teachers used their

knowledge to teach mathematics, the teachers connected different types of knowledge rather than relying only on one category of knowledge.

Consequently, it seems that according to the literature and research that PCK represents the subject matter for teaching and learning (Parker & Heywood, 2000; An, Kulm & Wu, 2004). However, analysis of data for this current study suggests that for some of the teachers PCK may be located in the intersection among the other categories of teachers' knowledge to teach mathematics, as presented in Figure 8.8. To emphasize its mathematics characteristics, this study refers to it as Mathematics Pedagogical Content Knowledge (MPCK).

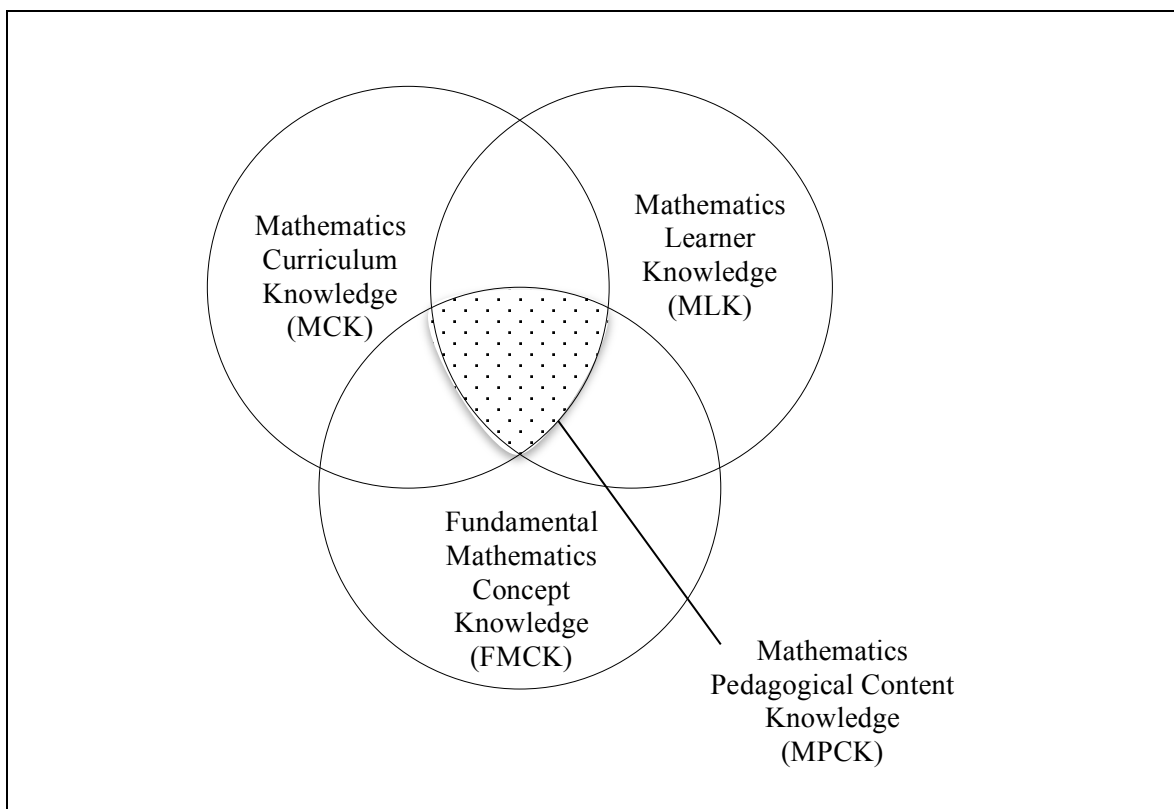

Figure 8.8. Intersection Among the Categories of Teachers' Knowledge for Teaching Mathematics

As noted in the previous section, the intersection among categories does not imply simply combined knowledge. Rather, it may represent a certain range of a category that would be meaningful to mathematics instruction by connecting information from different categories. Therefore, MPCK is a conjunctive form of information that is provided from three categories of knowledge for teaching mathematics: Mathematics Curriculum Knowledge, Mathematics Learner Knowledge, and Fundamental Mathematics Conceptual Knowledge. MPCK should be distinguished from the intersection of two categories in order to emphasize effective mathematics teaching in the classroom. For example, a teacher may teach mathematics concepts to students without Mathematics Curriculum Knowledge. If a teacher interprets mathematics concepts based on students' mathematical background and knows how to support his or her students' understanding of concepts, he or she may teach mathematics to students. However, it may be difficult for teachers to explain mathematics instruction in a school setting without mentioning the mathematics curriculum. Also, the findings from Chapter 4 to 7 suggest that it is more likely that teachers will provide qualified mathematics instruction when they have rich knowledge in three categories and know how to connect them.

MPCK may allow teachers to support their students' understanding of mathematics concepts based on the curriculum. The following passage from the lesson plan may provide some clues regarding teachers' MPCK. Mrs. Kim generated implications for her mathematics instruction based on her MPCK created by connecting three categories, as noted by providing a detailed description in her lesson plans:

Among 42 students in my classroom, 33 students (83%) had learned today's topic from their private institutions. In this case, the students may not focus on the

lesson because they may believe that they already know the concepts. To support these students, I need student-centered activities that might interest students.

Although 83% of students had learned about the concepts from their private institution, most of them are still struggling with drawing shapes on grid paper.

This may demonstrate that there needs to be activities that connect the basic concept of shapes to the drawing process. In addition, although the students understand most of the related concepts such as edges or spaces, some of my students may have difficulties recognizing parallel lines in a shape. Therefore, I need to prepare diverse activities according to the students' gaps.

Understanding the concepts of shapes may illustrate recognizing the properties of the shape that distinguish it from the other shapes. At the elementary level, students may recognize these characteristics intuitively rather than prove it in mathematical ways. Also, according to the curriculum, drawing shapes in fourth grade does not need to be precise in terms of mathematical proof. At this grade, students may be required to learn how to use a protractor and a compass to draw shapes and to enrich their understanding while they draw the shape. Thus, I may include diverse drawing activities such as using geoboards based on students' levels of understanding and skills.

From the description, it is clear Mrs. Kim considered the National Mathematics Curriculum, students' mathematics background, and related mathematics concepts connected to the topic in order to develop appropriate activities for addressing students' learning levels. Mrs. Kim used and interpreted her knowledge in each category by

combining the other types of knowledge and generated implications for her mathematics instruction.

In this section, I will not present the results of the analysis regarding the teachers' use of MPCK in their mathematics instruction, as it overlaps with the findings presented in the previous chapters. Although this study offered three basic categories of teachers' knowledge for teaching mathematics in Chapters 4 through 7, the findings of each chapter indicate the range of each category that the teachers decided to use for their mathematics instruction, which are located in the intersections of the three categories discussed earlier. For example, when the teachers developed the flow of learning based on their Mathematics Curriculum Knowledge, the teacher already had used his or her Fundamental Mathematics Concepts Knowledge and Mathematics Learner Knowledge. The teachers may have three types of knowledge; however, when they were connected to mathematics instruction, the parts of their knowledge that were used for the instruction overlapped with where Mathematics Pedagogical Content Knowledge emerged.

Therefore, it is essential to note that the three key categories of knowledge for teaching mathematics that generated MPCK might be specialized in this study. As discussed in Chapter 4, for the South Korea Educational System, the National Mathematics Curriculum plays a pivotal role in classroom teaching and evaluation of students' understanding. Thus, there is a need for further investigation on how Mathematics Curriculum Knowledge influences teachers' PCK in countries that do not provide a strict national curriculum or for teachers who work in a school that has its own curriculum system. In addition, there might be other knowledge categories that can affect mathematics instruction. This study generated themes and codes that remain common in

11 cases of South Korean elementary teachers as noted in Chapter 3. Thus, there were themes and codes that were not discussed in this study, as they did not emerge across all cases. For example, Mrs. Kim mentioned that she considered mathematics education theories when she develops her lesson plans, while the other teachers answered that they did not. The three categories of this study represent basic knowledge elements that may be consistent with MPCK. Thus, there needs to be further investigation of effective mathematics instruction that connect other categories of teachers' knowledge such as mathematics education theories or relationships with other subject areas.

Mathematics Pedagogical Procedural Knowledge

In the previous section, this study focused on the connections among categories of elementary teachers' knowledge for teaching mathematics and suggested that Mathematics Pedagogical Content Knowledge might have emerged based on these relationships; South Korean elementary teachers should know how to connect different categories of knowledge to teach mathematics as well as have in-depth knowledge in each category. Thus, the discussion regarding Mathematics Pedagogical Content Knowledge would be meaningless without addressing how the teachers may connect information from their categories of knowledge to teach mathematics based on a particular topic.

From the analysis of the lesson plans and interviews, I found that there were common procedures the teachers used to develop Mathematics Pedagogical Content Knowledge. In this study, I defined the teachers' knowledge that relates to these procedures as Mathematics Pedagogical Procedural Knowledge (MPPK) to emphasize its procedural characteristics to draw Mathematics Pedagogical Content Knowledge from

different types of knowledge to teach mathematics. Some studies argue that teachers' understandings of a certain instructional procedure might be one type of teaching strategies (e.g., Crawford & Witee, 1999; Kameenui & Carnine, 2011). However, I took Skemp's idea that it is one specific type of knowledge to know the procedures of solving mathematics problems. Although Skemp defined procedural knowledge from students' problem-solving processes, he argued that to know procedures might be just one type of knowledge (1987). Therefore, MPPK refers to teachers' procedural knowledge to draw Mathematics Pedagogical Content Knowledge based on the relationships among diverse categories of knowledge to teach mathematics. To reveal MPPK, it would be helpful to understand the relationships between categories of knowledge for teaching mathematics and Mathematics Pedagogical Content Knowledge, as this is expected to illustrate how the teachers combine different categories of knowledge for teaching mathematics. As noted previously, there have not been many discussions on how categories of knowledge might be connected to generate Mathematics Pedagogical Content Knowledge.

In this study, I presented the model for obtaining Mathematics Pedagogical Content Knowledge to demonstrate MPPK. The procedures of connecting diverse information may differ according to various factors such as each teacher's depth of knowledge or beliefs about mathematics education. For this reason, the discussion regarding how teachers obtain Pedagogical Content Knowledge has not received attentions regardless of the significance of Pedagogical Content Knowledge in classroom teaching. However, I found that there are common procedures the teachers used to connect diverse types of information for mathematics instruction based on the analysis of the lesson plans and interviews; the model was developed along with the findings. The

prototype of the model was found from the analysis of the lesson plans. Although the 11 teachers in this study were selected from different districts in Seoul, their lesson plans consisted of the same structure following a similar order: the objectives of the textbook chapter, students' learning sequences related to the topic based on the National Mathematics Curriculum, students' characteristics, implications or considerations of the mathematics lesson, and the detailed lesson plan for mathematics instruction. In some cases, the teachers added different sections in their lesson plans based on their understandings of the topic or educational purpose (e.g., investigations on the mathematics concepts or on the teaching model), or they followed the structure presented above. Based on the common structure of the lesson plans, the procedural model for MPPK is constructed as shown in Figure 8.9.

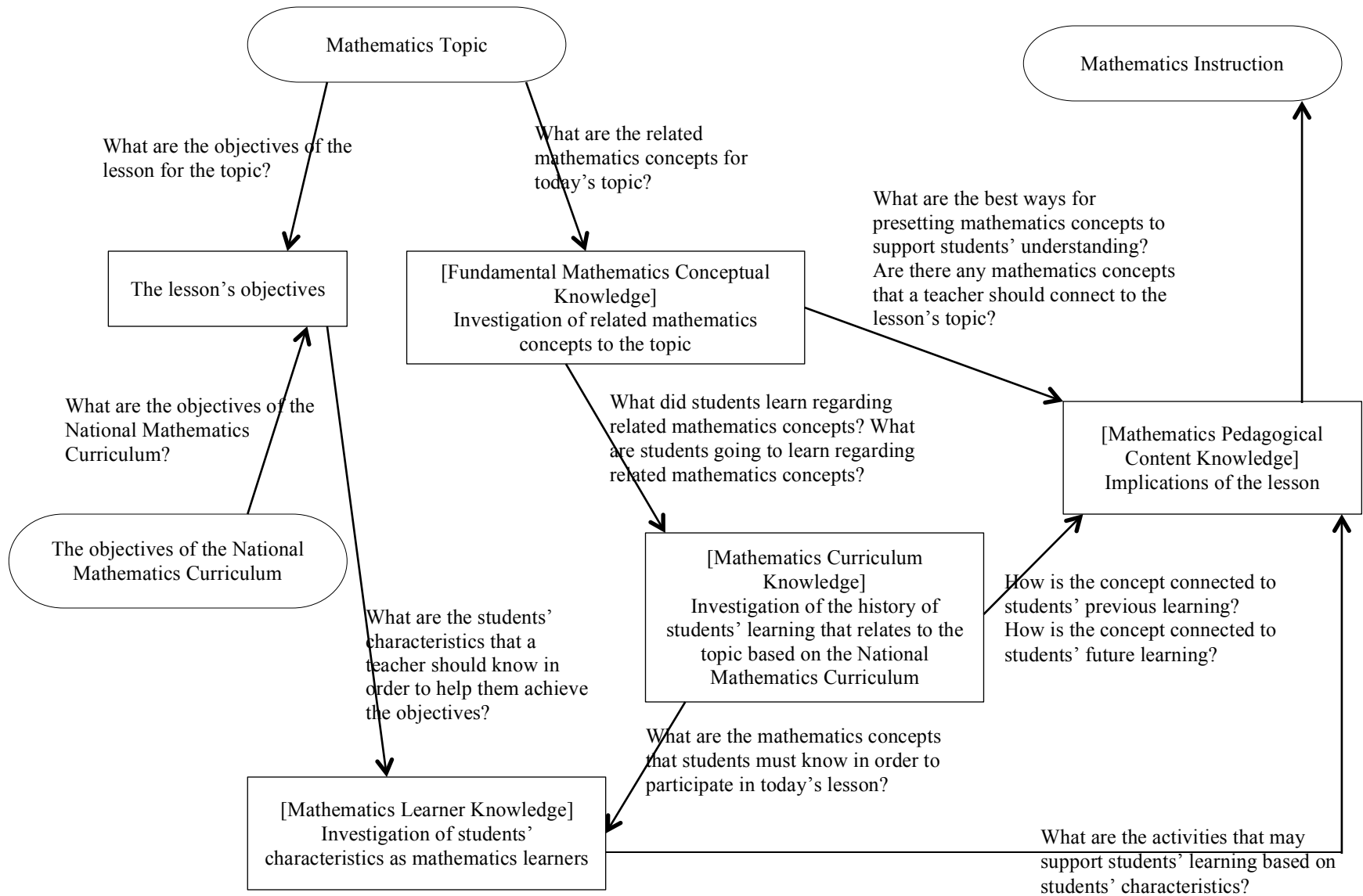

Figure 8.9. The Model for Mathematics Pedagogical Procedural Knowledge

In Figure 8.9, the texts in the ovals indicate the mathematics topics or objectives based on the National Mathematics Curriculum. The phrases in the rectangles represent both the major steps for developing mathematics lessons and categories of knowledge for teaching mathematics. The arrows illustrate the process of developing mathematics instruction, and the questions on the arrows indicate the relationships between the major steps. As discussed in the previous section, one category may provide the criteria for applying the other categories of knowledge for teaching mathematics. Therefore, the questions on arrows also represent the basic information for developing that criterion. As shown in Figure 8.9, teachers' knowledge for teaching mathematics influences mathematics instruction that is the product of planning. In this case, mathematics instruction includes the process of developing lesson plans, classroom teaching, and assessing students' works as defined from the conceptual framework in Chapter 1.

The model illustrates Mathematics Pedagogical Procedural Knowledge may not be a linear process. Rather, it is complicated, and each step affects other phases in the process. When planning mathematics instruction according to the National Mathematics Curriculum, the teachers attempted to set up lesson goals based on the objectives of the National Mathematics Curriculum. At the same time, the teachers considered related mathematics concepts to the topic. As shown in the previous chapters, the teachers used their Mathematics Curriculum Knowledge, Fundamental Mathematics Concepts Knowledge, and Mathematics Learner Knowledge in different ways that include Mathematics Pedagogical Content Knowledge. As a whole, Mathematics Pedagogical Content Knowledge, which may include some parts of the other categories of knowledge, may influence mathematics instruction as presented in Figure 8.9.

So far, although many studies have pointed out the importance of Pedagogical Content Knowledge in mathematics instruction as examined above, there were not many discussions on how teachers acquire Pedagogical Content Knowledge. The findings in this section suggest that teachers may have knowledge, which comprises a logical process that includes Pedagogical Content Knowledge. As noted in Chapter 3, the study's findings might be notable characteristics of South Korean Elementary teachers, as this study applied multiple case studies approaches including context-based results of the data analysis. However, the existence of MPPK in South Korean elementary teachers' knowledge for teaching mathematics might suggest that there needs to be more investigations on how U.S. teachers create Pedagogical Content Knowledge. These investigations might be extended to include studies in other content areas such as science and history.

The Structure of South Korean Elementary Teachers' Knowledge for Teaching Mathematics

As discussed in the previous section of this chapter, South Korean elementary teachers' knowledge for teaching mathematics consists of five categories: Mathematics Curriculum Knowledge, Mathematics Learner Knowledge, Fundamental Mathematics Conceptual Knowledge, Mathematics Pedagogical Content Knowledge, and Mathematics Pedagogical Procedural Knowledge. Among them, Mathematics Curriculum Knowledge, Mathematics Learner Knowledge, and Fundamental Mathematics Conceptual Knowledge may provide the grounds for generating Mathematics Pedagogical Content Knowledge with Mathematics Pedagogical Procedural Knowledge. The three basic categories of knowledge may play a significant role in mathematics instruction as an integrated form

within Mathematics Pedagogical Content Knowledge. In addition, the teachers in this study reported that their knowledge has been improved through their teaching experiences. Based on the findings, I developed a structure model of South Korean elementary teachers' knowledge for teaching mathematics as demonstrated in Figure 8.10.

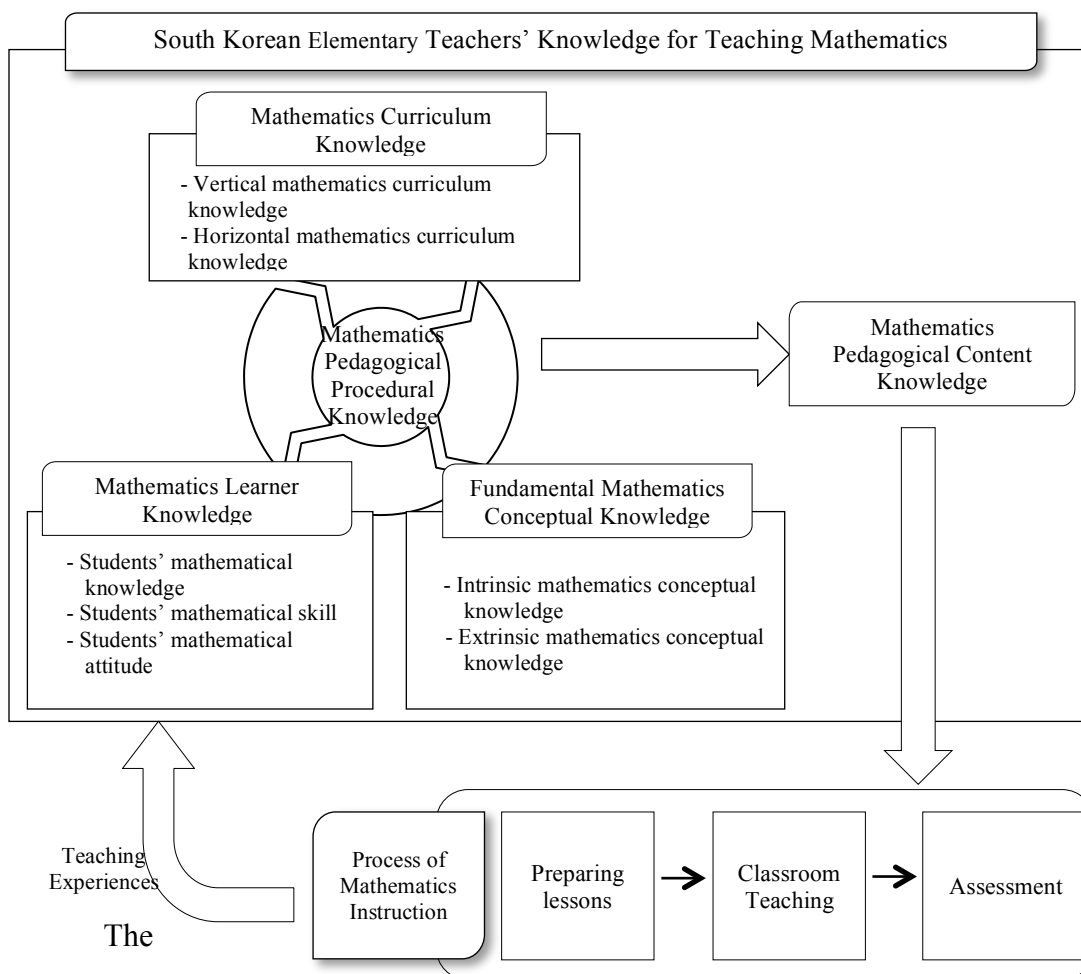

Figure 8.10. The structure of South Korean Elementary Teachers' Knowledge for Teaching Mathematics

notable aspect of the model is that Pedagogical Content Knowledge might not be the sum of the other categories of knowledge, and teachers may need procedural knowledge to generate Mathematics Pedagogical Content Knowledge. Elementary teachers may teach

mathematics relying on one or two categories of their knowledge such as Fundamental Mathematics Conceptual Knowledge or Mathematics Curriculum Knowledge without Mathematics Pedagogical Content Knowledge, as these have significant influences on mathematics instruction themselves as shown in previous chapters. However, as discussed in Chapter 2, elementary teachers should know how to teach mathematics concepts according to students' backgrounds based on the school curriculum, and this knowledge distinguishes teachers' ways of teaching mathematics from mathematicians' ways of teaching (Ball, et al., 2008). The teachers in this study also used their knowledge in a conjunctive form, which I discussed in the previous section. Thus, in this model, I illustrated how Mathematics Curriculum Knowledge, Mathematics Learner Knowledge, and Fundamental Mathematics Conceptual Knowledge may influence mathematics instruction within the form of Mathematics Pedagogical Content Knowledge.

Another noteworthy feature of this model is that Mathematics Curriculum Knowledge, Mathematics Learner Knowledge, and Fundamental Mathematics Conceptual Knowledge are also as important as is Mathematics Pedagogical Content Knowledge. So far, diverse studies point out the importance of Pedagogical Content Knowledge and suggest ways to improve it. However, the discussion about Pedagogical Content Knowledge too often focuses on itself, overlooking the substance of the other categories of knowledge. In the model, the three categories of knowledge may provide the basis for Mathematics Pedagogical Content Knowledge. Thus, teachers may generate robust Mathematics Pedagogical Content Knowledge by utilizing in-depth knowledge of the other three categories.

Interpretive Summary

In this chapter, I discussed how teachers' knowledge for teaching mathematics might have a three-dimensional, web-shaped structure according to Hiebert and Carpenter's (1992) assertion. Based on the researchers' argument, I presented a model of teachers' knowledge for teaching mathematics noting that there might be a possibility that the shape of the network for each teacher might be different. The model consists of key information (mathematic topics, students' characteristics, and mathematics concepts) and the relationships among them. One of the notable aspects in this model is that not all types of key information might be connected to one other. Using the model, I analyzed the relationship among categories of South Korean elementary teachers' knowledge for teaching mathematics, acknowledging that the teachers used some parts of each categories rather than applying the entire knowledge they have about their mathematics instruction. From the analysis, I found that the teachers use some part of their categories of knowledge to teach mathematics by considering the other categories, and the connection among categories might be created by the teachers' intentions or educational purpose for teaching mathematics. This study named the range where the connections formed as *intersection*: The intersection among categories does not simply imply combined knowledge. Rather, it may represent a certain range of a category that is meaningful to mathematics instruction by connecting other information from the different categories.

Based on the relationship among the categories, I found that Mathematics Pedagogical Content Knowledge is a conjunctive form of information that is provided from the three categories of knowledge for teaching mathematics: Mathematics

Curriculum Knowledge, Mathematics Learner Knowledge, and Fundamental Mathematics Conceptual Knowledge. From the results of the data analysis, it was revealed that the basic three categories of knowledge might influence the mathematics instructional process as a conjunctive form in Mathematics Pedagogical Content Knowledge. The notable difference between Mathematics Pedagogical Content Knowledge and previous assumptions regarding Pedagogical Content Knowledge is that Mathematics Pedagogical Content Knowledge may not be salient even though a teacher has knowledge in each category, if he or she does not know how to connect information from them. In addition, teachers should know how to choose meaningful information for mathematics instruction from the relationships among the categories.

I also found that the teachers used Mathematics Pedagogical Procedural Knowledge to generate Mathematics Pedagogical Content Knowledge from the other three categories of knowledge for teaching mathematics. Based on the analysis of the lesson plans and interviews, I presented a model for Mathematics Pedagogical Procedural Knowledge. In this model, the National Mathematics Curriculum played a pivotal role in Mathematics Pedagogical Knowledge as well as in the Mathematics Pedagogical Procedure Knowledge model. This might be unique to South Korean elementary teachers, as there is a robust curriculum system in South Korea.

Overall, I found that South Korean elementary teachers' knowledge for teaching mathematics consists of five categories: Mathematics Curriculum Knowledge, Mathematics Learner Knowledge, Fundamental Mathematics Conceptual Knowledge, Mathematics Pedagogical Content Knowledge, and Mathematics Pedagogical Procedural Knowledge. Among them, Mathematics Curriculum Knowledge, Mathematics Learner

Knowledge, and Fundamental Mathematics Conceptual Knowledge may provide grounds for generating Mathematics Pedagogical Content Knowledge with Mathematics Pedagogical Procedural Knowledge. These three basic categories of knowledge may play a significant role in mathematics instruction as an integrated form of Mathematics Pedagogical Content Knowledge.

CHAPTER 9

Summary, Conclusions and Implications

The previous four chapters presented detailed information about the findings of this study. Each chapter provided descriptions of each category of knowledge for teaching mathematics by defining and clarifying its relationship to mathematics instruction. In particular, from Chapters 5 through 7, I discussed the major categories of knowledge for teaching mathematics that consist of Mathematics Pedagogical Content Knowledge: Mathematics Curriculum Knowledge, Mathematics Learner Knowledge and Fundamental Mathematics Concepts Knowledge. In Chapter 8, I focused on the relationship among these categories and how the relationships might generate Mathematics Pedagogical Content Knowledge. In addition, this study also demonstrated that Mathematics Pedagogical Procedural Knowledge might play a pivotal role in constructing Mathematics Pedagogical Content Knowledge.

This chapter summarizes the study, highlighting the importance of the findings. In addition, further discussion of the findings is provided suggesting how they contribute to existing research about elementary teachers' knowledge for teaching mathematics. This chapter also includes conclusions drawing from the findings and their implications for the field as well as the limitations of the study and recommendations for future research.

Summary of the Study

The purpose of this research was to identify the categories of South Korean elementary teachers' knowledge for teaching mathematics. Operating under the assumption that elementary teachers' knowledge for teaching affects students' learning, 11 South Korean elementary teachers volunteered to participate in this study. The

research question of this study is as follows:

What types of mathematics knowledge do South Korean elementary teachers use in their mathematics instruction?

This study is also informed by the following subquestions:

1. How does each category of South Korean elementary teachers' knowledge for teaching mathematics influence their mathematics instruction?
2. How is each category of the South Korean elementary teachers' knowledge for teaching mathematics structured?
3. How does each category of the South Korean elementary teachers' knowledge for teaching mathematics relate to one another?

Each of these subquestions is directly related to the overriding research question; hence, each was examined to uncover the characteristics of South Korean elementary teachers' knowledge for teaching mathematics.

According to the theoretical orientation, teachers' use of language is key to students' understanding of mathematics. This study focused on teachers' use of language in their mathematics instruction rather than on developing a questionnaire to assess the teachers' knowledge for teaching mathematics (e.g., Hill, Schilling & Ball, 2004; Dalaney, Ball, Hill, Schiling, & Zopf, 2008) or investigating students' outcomes (e.g., Hill, Rowan, & Ball, 2005; Tanase, 2011). In addition, the conceptual framework regarding the range of the teaching process guided the diverse aspects of this study: preparing lessons, classroom teaching, and assessing students' work. Data were collected according to these three stages of the teaching process.

The intention of this qualitative study, which integrates multiple cases study

approaches of sociolinguistic tradition and grounded theory, was to identify and to describe the South Korean elementary teachers' knowledge for teaching mathematics; various elements (e.g., observation, lesson plans, and interviews) from the 11 participants were analyzed as they were collected, and the analysis affected the process of future data gathering. Applying the methods of grounded theory, several multilayer models were constructed to illustrate how the categories of knowledge were inclusive of Mathematics Pedagogical Content Knowledge and how these categories influenced mathematics instruction. In the phases of analyzing data, member-checking strategies and data triangulation were applied to limit researcher's bias.

Based on the assumption that a qualitative approach needs appropriate interpretations about specific surroundings (Erickson, 1986), I analyzed the educational context of South Korea. The results of analysis provided grounds to understand the influence of the National Mathematics Curriculum on both classroom settings and South Korean elementary teachers' knowledge for teaching mathematics.

Emerging from the data I collected and the subsequent analysis are five categories of South Korean elementary teachers' knowledge for teaching mathematics: Mathematics Curriculum Knowledge, Mathematics Learner Knowledge, Fundamental Mathematics Conceptual Knowledge, Mathematics Pedagogical Content Knowledge, and Mathematics Pedagogical Procedural Knowledge. The definition of these five categories and related findings are as follows:

First, Mathematics Curriculum Knowledge indicates teachers' understanding of the sequence among mathematical concepts that exist both inter-grade and intra-grade according to the National Mathematics Curriculum. Mathematics Curriculum Knowledge

is divided into two subcategories, which are referred to as vertical mathematics curriculum knowledge and horizontal mathematics curriculum knowledge. Vertical mathematics curriculum knowledge represents the general order of what students learn across each grade (e.g., mathematics topics across grades one to three). Horizontal mathematics curriculum knowledge (HMCK) is composed of the mathematics curriculum at one grade level (e.g., mathematics topics for first grade). A finding emerging from the data analysis is that the teachers' Mathematics Curriculum Knowledge served as a catalyst for investigating their students' mathematical background and experiences. In particular, Mathematics Curriculum Knowledge provided the scope of the content to consider when the teachers worked with their students to help them make mathematical connections.

Second, Mathematics Learner Knowledge is related to teachers' understanding of the characteristics of mathematics learners and how it is used in their mathematics instruction. This study demonstrated that there are key subcategories of Mathematics Learner Knowledge based on the analyses of the lesson plans: students' mathematical knowledge, students' mathematical skills, and students' mathematical attitude. In this case, *students* represent mathematics learners who are learning mathematics in formal classroom settings according to the National Mathematics Curriculum. In addition, *students' mathematical knowledge* represents students' conceptual understanding of mathematics, while *mathematical skills* indicate both students' procedural understanding and skills needed to solve mathematics problems. *Students' mathematical attitude* involves students' preference for and value of mathematics. These three key subcategories were characterized based the objectives of the lessons developed according

to the National Mathematics Curriculum. The three key subcategories that related to objectives of the lesson were useful to the teachers participating in this study when they developed lesson plans, taught the lessons, and assessed student learning.

Third, Fundamental Mathematics Conceptual Knowledge indicates teachers' understanding of mental representations of mathematics topics and the relationship among them. It also includes knowledge that may convert abstract mathematics concepts into a form, which supports learners' understanding of them. Fundamental Mathematics Conceptual Knowledge is divided into two subcategories: Intrinsic Mathematics Conceptual Knowledge and Extrinsic Mathematics Conceptual Knowledge. Intrinsic Mathematics Conceptual Knowledge demonstrates teachers' knowledge of abstract mental representations of a mathematics topic and how to provide sensory experiences to their students to support their development of mental representations. Extrinsic Mathematics Conceptual Knowledge illustrates teachers' knowledge regarding the relationship among mathematical mental representations and how to present them during a mathematics lesson to support their students' understanding of them. This study found that the teachers used Fundamental Mathematics Conceptual Knowledge when they were planning mathematics lessons by clarifying both the mathematics concept itself and the relationship among mathematical concepts and by extracting meaningful implications from them. In addition, the teachers used their Fundamental Mathematics Conceptual Knowledge during their conversations with students during mathematics instruction. From the analysis of observed lessons, I also found that Fundamental Mathematics Conceptual Knowledge might include embryologic origins of mathematics concepts.

Fourth, Mathematics Pedagogical Content Knowledge indicates the conjunctive

form of knowledge of Mathematics Curriculum Knowledge, Mathematics Learner Knowledge, and Fundamental Mathematics Conceptual Knowledge. From the process of revealing the characteristics of South Korean elementary teachers' knowledge for teaching mathematics, I found that the teachers used only parts of their subcategories of knowledge and connected information of each part to others to extract meaningful implications for their mathematics instruction. The information might be connected to each other in the intersection among subcategories of knowledge, and they may influence mathematics instruction. The intersection of the subcategories is where Mathematics Pedagogical Content Knowledge is located.

Fifth, Mathematics Pedagogical Procedural Knowledge designates how the teachers' knowledge is related to common procedures the teachers might use in develop Mathematics Pedagogical Content Knowledge. From the analysis of lesson plans, I presented several multilayer models that illustrated how Mathematics Pedagogical Content Knowledge along with Mathematics Pedagogical Procedural Knowledge influenced the lesson planning and classroom teaching.

Consequently, the first three basic categories of knowledge play a significant role in mathematics instruction as an integrated form within Mathematics Pedagogical Content Knowledge. The notable aspect of this study's findings is that Pedagogical Content Knowledge might not be the sum of the other categories of knowledge and that teachers may need procedural knowledge to generate Mathematics Pedagogical Content Knowledge.

Another significant finding of this study is that the teachers' teaching experiences may affect their knowledge for teaching mathematics. In particular, the teachers reported

that they did not know how to connect different types of information (e.g., mathematics curriculum, students' mathematics backgrounds, related mathematics concepts to the topic) to mathematics instruction when they were novice teachers. The teachers stated that they realized the relationships among different types of information as a result of their teaching experiences. This implies that teachers' teaching experiences may affect teachers' Mathematics Pedagogical Procedural Knowledge. Based on these findings, this study presented a structure model of the South Korean elementary teachers' knowledge for teaching mathematics in Chapter 8. Further discussion of the study findings and how they might provide implications for the field of mathematics education is presented later in this chapter.

Discussion of Findings

The purpose of this study was to reveal South Korean elementary teachers' knowledge for teaching mathematics and the relationship among its categories. The study's findings focused on categories of South Korean elementary teachers' knowledge for teaching mathematics. In this section, I will present how the study's findings compared and contrasted to the literature.

Mathematics Curriculum Knowledge

The data's analysis indicated that Mathematics Curriculum Knowledge is one of the important categories of South Korean elementary teachers' knowledge for teaching mathematics when conducting mathematics instruction. Various cases of the participants' mathematics instruction supported this argument. The eleven teachers used their knowledge regarding the relationship among mathematics topics according to the National Mathematics Curriculum in their instruction. They used MCK for analyzing

their students' mathematical background when they develop lesson plans and when they assess students' mathematics works. In addition, the teachers' MCK affected how they organized activities and used mathematical vocabularies during the lesson. The teachers also tried to make connections among mathematics topics when they taught mathematics based on their MCK. Thus, a conclusion is that MCK might affect the teachers' mathematics instruction. This finding is different from previous arguments stating that teachers' curriculum knowledge does not directly relate to teachers' teaching, although it may provide some background knowledge for teaching mathematics (e.g., Shulman, 1987; Ball, Thames & Phelps, 2008).

Although this study did not focus on how the teachers might acquire their knowledge for teaching mathematics, a further insight of this study is that the participants might acquire MCK from teaching experiences across various grade levels. Although there are studies that proposed that elementary teachers who have had experience with a wider range of grades have better knowledge to teach mathematics than do who have taught only one or two elementary grades (e.g., Chinnappan & Lawson, 2005; Ng, 2011), it is still unclear how teaching experience contributes to teachers' knowledge for teaching. The study's findings demonstrate that teachers' teaching experience across diverse grade levels helped them understand the mathematics topics covered in the curriculum that relate to their MCK.

Mathematics Learner Knowledge

Results from the data analysis showed that South Korean elementary teachers' Mathematics Learner Knowledge (MLK) might play a pivotal role in their mathematics instruction. In particular, MLK consists of three key subcategories: students' knowledge,

students' skills, and students' attitude. The teachers reported that they needed to have knowledge in at least these three subcategories to help their students achieve the objectives of the mathematics lesson developed by the National Mathematics Curriculum. According to the National Mathematics Curriculum, teachers should consider their students' knowledge, skills, and attitudes concerning the lesson's objectives. The teachers' MLK affected their mathematics instruction in diverse ways. This study discussed how MLK might affect teachers' decision-making processes regarding selecting mathematical activities and manipulatives according to students' characteristics. The teachers also were able to communicate with all the students during the lesson effectively, considering their students' cognitive and emotional status, by making use of MLK during the lesson. In addition, the teachers used MLK when they analyzed students' mathematical background and assessed their work.

The findings are in keeping with previous studies' outcomes, which suggested that elementary teachers should have broad and deep knowledge of students' nonstandard strategies in addition to having a way to address them (Anderson & Kim, 2003; Empson & Junk, 2004; Kleve, 2010). However, the definition of knowledge regarding mathematics learners is vague, but there is agreement that teachers should have knowledge of their students' mathematical background and characteristics and how these features can be used to adjust instruction. It might be difficult to define students' mathematical background or characteristics, as there are too many aspects to consider. For example, teachers should know their students' preconceptions of mathematics (Donovan & Bransford, 2005), educational context (Fennema & Franke, 1992), students' emotional development based on their age (Golbeck & Ginburg, 2004), the role of private

tutors and tutoring centers (Choi, 2013) and even the ethnic groups students belong to (NCTM, 2000). The study's findings suggest that elementary teachers should have knowledge of their students regarding at least students' characteristics that might be related to the mathematics lessons' objectives.

Fundamental Mathematics Conceptual Knowledge

Another finding is that the South Korean elementary teachers participating in this study have Fundamental Mathematics Concepts Knowledge. Fundamental Mathematics Conceptual Knowledge consists of Intrinsic Mathematics Conceptual Knowledge and Extrinsic Mathematics Conceptual Knowledge. Results of the lesson plans' analysis, observation, and related interviews suggested that the study's teachers used both Intrinsic Mathematics Conceptual Knowledge and Extrinsic Mathematics Conceptual Knowledge when they prepared lessons, conducted classroom teaching, and assessed students' mathematical work.

The findings are in keeping with the assertions of previous studies that elementary teachers should know how to provide opportunities that help their students develop mathematics concepts. However, previous studies put more emphasis on how to connect mathematics concepts, defined as Extrinsic Mathematics Conceptual Knowledge in this study. For example, Ma (1999) stated that teachers need to have a "profound understanding of fundamental mathematics" (p.107), which represents a composite network of mathematics topics. According to Ma (1999), teachers who have a profound understanding of fundamental mathematics may present the relationship between mathematical concepts and their procedures to their students effectively by recognizing diverse aspects and related mathematical ideas of one mathematics concept. Kilpatrick,

Swafford, and Findell (2001) also stated that elementary teachers should know how to help their students connect mathematics concepts based on an understanding of abstract mathematics concepts. However, as shown in this study, teachers' Intrinsic Mathematics Conceptual Knowledge is also a significant factor in designing mathematics activities, which provides mathematical experience that supports students' development of mathematics concepts. The teachers in this study showed a strong knowledge basis of mathematics concepts and know how to connect these concepts to one another. This may show that the teachers' Extrinsic Mathematics Conceptual Knowledge becomes robust based on Intrinsic Mathematics Conceptual Knowledge.

Mathematics Pedagogical Content Knowledge and Mathematics Pedagogical Procedural Knowledge

This section discusses two categories of South Korean elementary teachers' knowledge for teaching mathematics, as one of them cannot be explained without discussing the other category: Mathematics Pedagogical Content Knowledge and Mathematics Pedagogical Procedural Knowledge.

Mathematics Pedagogical Content Knowledge emerged from the relationship among the other categories of knowledge for teaching mathematics based on the assumption that knowledge might be structured as a network. In addition, the results of analysis from the study proposed that Mathematics Pedagogical Content Knowledge may be located in the intersection among the other categories of elementary teachers' knowledge for teaching mathematics. However, Mathematics Pedagogical Procedural Knowledge refers to teachers' procedural knowledge to draw on Mathematics

Pedagogical Content Knowledge based on the relationships among diverse categories of knowledge for teaching mathematics in this study.

Although diverse studies point out the importance of Pedagogical Content Knowledge in mathematics instruction as discussed above, there were not many discussions on how teachers might acquire Pedagogical Content Knowledge. This section's findings suggest that teachers might have knowledge that includes a logical process for consisting Pedagogical Content Knowledge. As noted previously, the study's findings might show notable characteristics of South Korean Elementary teachers, as this study applied multiple case studies approaches, including context-based results of data analysis. However, the existence of Mathematics Pedagogical Procedural Knowledge in South Korean elementary teachers' knowledge for teaching mathematics may suggest that there needs to be more investigations on how U.S. teachers create Pedagogical Content Knowledge. This research might be conducted in the area of mathematics as well as in other educational fields (e.g., science, history) that emphasize teachers' Pedagogical Content Knowledge.

Conclusions and Implications

Operating within the framework, I viewed the process of mathematics instruction considering three stages: preparing lesson plans, classroom teaching, and assessment. In addition, with the assumption that internal representations in teachers' knowledge might be connected to one another in useful ways, I analyzed 11 South Korean elementary teachers' mathematics instruction using data from interviews, observations, and lesson plans. From the findings, this study revealed that there are five categories of knowledge for teaching mathematics and that the categories are connected to each other. The in-

depth descriptions for each category were discussed in Chapter 5 through Chapter 8 and were summarized in the discussion section above. This section presents the conclusions and implications of the major findings that might be meaningful for teachers, teacher educators, administrators, and policy makers.

This study revealed that all five major categories of South Korean elementary teachers' knowledge for teaching mathematics play a pivotal role in mathematics instruction. It might provide some clues about what makes elementary mathematics teachers professionals. The findings of this study suggest that even mathematicians who have high mathematical content knowledge might not teach well if they do not have mathematical knowledge of how to teach mathematics to elementary school students.

A major conclusion of this study is that Mathematics' Curriculum Knowledge is one of the main categories of South Korean elementary teachers' knowledge for teaching mathematics. Also, Mathematics Curriculum Knowledge may play a pivotal role in the process of generating Mathematics Pedagogical Content Knowledge. The teachers used their Mathematics Curriculum Knowledge to analyze their students' mathematical backgrounds and to determine the range of mathematics concepts to be covered in their mathematics classroom teaching. This conclusion might inform administrators and policy makers regarding how to improve elementary mathematics teacher education. An implication for South Korea is that those providing teacher education should offer in-depth experiences to preservice and inservice teachers that will assist them in understanding how to use the National Mathematics Curriculum to make connections across various grade levels as well as within a particular grade level with intensive teacher-practicum programs. The United States is in the implementation phases of a

nationwide mathematics curriculum, the Common Core State Standards. If elementary teachers' knowledge of the curriculum plays a pivotal role in their mathematics instruction, then policy makers should consider developing preservice and in-service elementary mathematics teacher education programs to improve teachers' knowledge of the Common Core State Standards.

Another of the study's conclusions is that South Korean elementary teachers use their knowledge of students' mathematical backgrounds and attitudes when planning mathematics lessons and activities related to the lessons' objectives. The South Korean teachers' Mathematics Learner Knowledge might differ from the U.S. teachers' understanding of their students, as the National Mathematics Curriculum may play a pivotal role in their mathematics instruction. However, the fact that the South Korean teachers attempted to understand their students based on the lessons' objectives might provide meaningful implications to American teachers. Teachers in the United States also need to consider what they need to know to assist students in accomplishing the teachers' lesson goals. As noted above, there are not many discussions on teachers' knowledge of mathematics learners. Thus, there needs to be more studies on what teachers should know about their students and how to use this knowledge for mathematics instruction. As Ball et al. (2008) pointed out, it would be meaningless to have in-depth knowledge of mathematics content if the teachers do not know how to support their students' understanding of mathematics concepts.

An essential category of South Korean elementary teacher's knowledge for teaching mathematics is Fundamental Mathematics Conceptual Knowledge. However, I suggest that there needs to be further investigation on what the nature of mathematics

education is and how South Korean elementary teachers' Fundamental Mathematics Conceptual Knowledge might fit into the nature. Schwab (1965) asserts that teachers' content knowledge should include knowledge of facts and concepts, the ways that they are organized, and the nature of inquiry in the field. Although this study focused on teachers' content knowledge by illuminating mathematics concepts, the investigation on the nature of inquiry in mathematics education was not included in the discussion, as no related themes or codes emerged from the data's analysis. Thus, there needs to be further research on what we want to teach in mathematics education and how the teachers' methods of presenting mathematics concepts should be changed.

A further notable conclusion of this study is that Pedagogical Content Knowledge might be not the sum of the other categories of knowledge for teaching mathematics. As noted previously, diverse studies emphasized the importance of Pedagogical Content Knowledge in the classroom teaching (e.g., An, Kulm, & Wu, 2004; Ball, Thames, & Phelps, 2009; Shulman, 1987). However, there has been a lack of discussion on how teachers might acquire Pedagogical Content Knowledge. Based on the data's analysis, I developed a model to demonstrate teachers' procedural knowledge based on the relationship among the other categories of South Korean elementary teachers' knowledge for teaching mathematics. The model illustrates that elementary schoolteachers should know how to connect their knowledge in each category as well as have in-depth knowledge in mathematics curriculum, characteristics of their students, and mathematics concepts. An implication is that this study could provide some clues for elementary mathematics teachers and teacher educators. For elementary teachers, this model might provide valuable information regarding how to improve their Pedagogical Content

Knowledge. The Mathematical Pedagogical Procedural Knowledge Model may illustrate to them how to connect different types of information from the categories of knowledge for teaching mathematics that might influence the instructional process. In addition, mathematics educators might develop practical courses to support teachers on how to acquire Pedagogical Content Knowledge for their instruction.

The role that teaching experience played in the South Korean elementary teachers' mathematics knowledge for teaching is a salient conclusion that can be drawn from this study. This study's teachers reported that their teaching experiences were helpful in improving their knowledge of the National Mathematics Curriculum. Therefore, an implication for the Ministry of Education in South Korea is to consider strengthening its mentoring program by providing mentors to beginning teachers. These mentors need to be experienced teachers who have been identified as outstanding and with deep knowledge of the National Mathematics Curriculum. The United States and other countries need to investigate the role teachers' experience has on the implementation of national mathematics standards and curriculum. Such an investigation would include examining the influence of experience on mathematics instruction. At the preservice level, mathematics teacher education programs might begin to strengthen the preservice teachers' understanding of the role of national standards and curriculum.

Diverse categories of South Korean elementary teachers' knowledge for teaching mathematics and the relationships among them have been presented. These findings might be connected to results from relevant studies in terms of the significant role of teachers' knowledge in mathematics instruction. This study may contribute further to the existing literature in that it provides empirical bases for understanding teachers'

knowledge for teaching mathematics and reveals the relationships among categories of knowledge for teaching mathematics. The fact that the teachers connected different types of categories rather than relying on one type of knowledge might also be significant to policy makers, teacher education programs, and teachers. To date, the basic assumption is that the categories of teachers' knowledge are independent of each other (e.g., Fennema & Franke, 1992; Shulman, 1987). Thus, research on relationships among categories of knowledge for teaching mathematics may not be clearly understood clearly (Marks, 1990; Eisenhart, Borko, Underhill, Brown, Jones, & Agard, 2012), and the teachers' education program might not be adequate in terms of applying the teachers' knowledge to their mathematics instruction (Hill, Shilling, & Ball, 2008). However, the notion that categories of knowledge for teaching mathematics might relate to each other by providing certain criteria for applying it to mathematics instruction may provide the grounds for supporting teachers to understand how they might use their knowledge by connecting categories of it.

Limitations of this Study

The study's goal was to implement a comprehensive study with multiple case study approaches; nevertheless, there were several limitations. A primary limitation of the study was the small number of cases. Thus, the findings may not be generalized to all cases of South Korean teachers, although this study focused on 11 cases of teachers by examining several elements. I was aware of this limitation throughout the research process and made some efforts to address it in the research design. While generalizability of the study might be increased with a larger sample size, it would have also limited the detailed description of each participant's case. The 11 cases, which were chosen

according to the criteria, provided some balance between finding similar patterns among cases and providing detailed descriptions of each case. In addition, although the findings of this study will not be generalizable through a statistical procedure orientation, it is intended to consider the interconnected notions of generalizability utilized in qualitative research: credibility, transferability, dependability, and conformability (Lincoln & Guba, 1983).

Another limitation of this study was that there was only a single interpreter used. This limitation was addressed by improving accuracy, credibility, validity, and transferability by applying diverse qualitative research approaches such as member checking and data triangulation as shown in Chapter 3.

Recommendations for Future Research

If we could identify elementary teachers' mathematical knowledge for teaching mathematics, then we might find ways to improve elementary mathematics teacher quality. However, there are not many empirical studies in this field as discussed in Chapter 2. Therefore, more research on elementary teachers' mathematical knowledge is needed. In addition, the number of scholars conducting research in the area of elementary teachers' mathematical knowledge is few. In completing the literature review search, I found that the same scholars from different studies seemed to emerge. Therefore, not only does more research in this area need to be done, but more important, there needs to be an increase in the numbers and types of scholars doing this work. Expanding the field of researchers provides new ways of examining elementary teachers' mathematical knowledge, and at the same time, it might provide critical information about the affects and factors of mathematical knowledge for teaching.

The study's findings offered tentative and context-specialized data results, as the number of participants was relatively small. The findings of this study might be validated through a quantitative investigation conducted on a larger scale. The categories of teachers' knowledge for teaching mathematics might provide some criteria for a quantitative investigation. In addition, this study only focused on South Korean teachers' cases. Thus, researchers might conduct research on teachers' knowledge for teaching mathematics in the United States or in other countries regarding the new categories of teachers' knowledge for teaching that this study revealed (e.g., Mathematical Pedagogical Procedural Knowledge).

Another line of research might be to select cases represented by middle school and high school teachers to examine whether similar categories of knowledge for teaching mathematics emerge. Conducting a study in which the focus is on middle and high school teachers will provide further insights on the role of national mathematics standards and curriculum.

Closing Comments

Since elementary mathematics education was defined as an academic field, countless mathematics educators have produced various theories and methods to improve elementary students' mathematical understanding. However, opinions still differ on how to provide effective teaching of mathematics. Elementary teachers' mathematical knowledge is extremely difficult to define in a single sentence. Therefore, we need wisdom to provide absolute meaning of what constitutes elementary teachers' knowledge. However, at the same time, we should continue investing in research and teacher education programs to improve elementary teachers' mathematical knowledge.

References

- Adelman, C., Jenkins, D., & Kemmis, S. (1983). Rethinking case study: Note from the second Cambridge conference. In *Case Study: An overview*. Case Study Methods 1 (Series). Victoria, Australia: Deakin University Press.
- Albert, L. R. (2012). *Rhetorical ways of thinking: Vygotskian theory and mathematical learning*. New York: Springer.
- An, S., Kulm, G., & Wu, Z. (2004). The pedagogical content knowledge of middle school, mathematics teachers in China and the U.S. *Journal of mathematics teacher education*. 145-172.
- Andelfinger, B. (1981). Provocative texts and spontaneous reactions of teachers: A method for recognizing teaching and learning of mathematics. In Equipe de Recherche Pédagogique (Eds.), *Proceedings of the 5th PME International Conference, 1*, 381–386.
- Anderson, H. & Kim, S. (2003). A missing piece in an elementary school mathematics teacher's knowledge base. *Teacher Education*, Vol. 12(n.2), 17–23.
- Anfara, V. A., Brown, K. M., & Mangione, T. L. (2002) Qualitative Analysis on Stage: Making the research process more public. *Educational Researcher*. 31(7). 28–38.
- Apple, M. (2008). Curriculum planning: Content, form, and the politics of accountability. In F. M. Connelly (Ed.), *The sage handbook* (25–44) Sage Publication.
- Ayres, L., Kavanaugh, K., & Knafl, K. A. (2003). Within-case and across-case approaches to qualitative data analysis. *Qualitative Health Research*, 13(6), 871–883.

- Ball, D. L., (1988). Knowledge and reasoning in mathematical pedagogy: Examining what prospective teachers bring to teacher education. Unpublished dissertation.
- Ball, D. L. (1991). Research on teaching mathematics: Making subject-matter knowledge part of the equation. In J. Brophy (Ed.), *Advances in research on teaching* (2, 1–48). Greenwich, CT: JAI Press Inc.
- Ball, D. L. (1993). With an eye on the mathematical horizon: Dilemmas of teaching elementary school mathematics. *Elementary School Journal*, 93(4), 373–397.
- Ball, D. L., & Bass, H. (2000). Interweaving content and pedagogy in teaching and learning to teach: Knowing and using mathematics. In J. Boaler (Ed.), *Multiple perspective on mathematics teaching and learning* (83–104). Westport, UK; Ablex.
- Ball, D. L., Lubienski, S. T., & Mewborn, D. S. (2001). Research on teaching mathematics: The unsolved problem of teachers' mathematical knowledge. In V. Richardson (Ed.), *Handbook of research on teaching* (4th ed., pp. 433–456). New York: Macmillan.
- Ball, D. L., Thames, M. H., & Phelps, G. (2008). Content knowledge for teaching: What makes it special? *Journal of Teacher Education*, 59(5), 389–407.
- Banks, J., Cochran-Smith, M., Moll, L., Richert, A., Zeichner, K., LePage, P., Darling Hammond, L., & Duffy, H. with McDonald, M. (2005). Teaching diverse learners. In L. Darling-Hammond & J. Bransford (Eds.), *Preparing teachers for a changing world: What teachers should learn and be able to do* (pp. 232–274). San Francisco: Jossey-Bass.

- Barnett, J., & Hodson, D. (2000). Pedagogical context knowledge: Toward a fuller understanding of what good science teachers know. *Science Teacher Education*. Ed 85. 426–453.
- Bass, H. (2005). Mathematics, mathematicians and mathematics education. *Bulletin of the American Mathematical Society*, 42(4), 417–430.
- Baucus, D. A., & Human, S. E. (1994). Second-career Entrepreneurs: A multiple case study analysis of entrepreneurial processes and antecedent, *Entrepreneurship: Theory & Practice*, 19(2), 4–31.
- Bell, C. A., Wilson, S., Higgins, T., & McCoach, D. B. (2010). Measuring the effects of professional development: The case of developing mathematical ideas. *Journal for Research in Mathematics Education*, 41(5), 479.
- Borko, H., & Putnam, R. T. (1996) Learning to teach. In D. C. Berliner & R. C. Calfee (Eds.), *Handbook of educational psychology* (pp. 637–708). New York; Macmillan.
- Borko H., Eisenhart, M., Brown, C. A., Underhill, R. G., Jones, D., & Agard, P. C. (1992). Learning to teach hard mathematics: Do novice teachers and their instructors give up too easily? *Journal for Research in Mathematics Education*, 23(3), 194–222.
- Borman, G., & Dowling, M. (2010). Schools and inequality: A multilevel analysis of Coleman’s Equality of Educational Opportunity data. *Teachers College Record*. Vol. 112(5), 1201–246.
- Bruner, J. (1986). *Actual minds, possible worlds*. Cambridge, MA: Harvard University.
- Brophy, J. (1997). Effective instruction. In H. J. Walberg and G.D. Haertel (Eds.), *Psychology and educational practice* (pp. 212–243). Berkeley, CA: McCutchan.

- Brophy, J. E., & Good, T. L. (1986). Teacher behavior and student achievement. In M. C. Wittrock (Ed.), *Handbook of research on teaching* (3rd ed., pp. 328–375). New York: Macmillan.
- Bullough, R. V. (2001). Pedagogical content knowledge circa 1907 and 1987: A study in the history of an idea. *Teaching and Teacher Education, 17*, 655–666.
- Cai, J. (2005). U.S. and Chinese teachers' constructing, knowing, and evaluating representations to teach mathematics. *Mathematical Thinking and Learning an International Journal, Vol. 7(2)*, 135–169.
- Calderhead, J., & Shorrock, S. (1997). *Understanding teacher education: Case studies in the professional development of beginning teachers*. London: Falmer Press.
- Carpenter, T. P., Fennema, E., Peterson, P. L., & Carey, D. A. (1988). Teachers' pedagogical content knowledge of students' problem solving in elementary arithmetic. *Journal for Research in Mathematics Education, (19)5*, 385–401.
- Carpenter, T. P., Fennema, E., Peterson, P. L., Chiang, C. P., & Loeff, M. (1989). Using knowledge of children's mathematics thinking in classroom teaching: An experimental study. *American Educational Research Journal, 26*, 499–531.
- Carpenter, T. P., Franke, M. L., Jacobs, V., & Fennema, E. (1998). A longitudinal study of invention and understanding in children's multidigit addition and subtraction. *Journal for Research in Mathematics Education, 29*, 3–20.
- Carpenter, T. P., & Lehrer, R. (1999). Teaching and learning mathematics with understanding. In Fennema, E., & Romberg, T. A. (Eds.), *Mathematics classroom that promote understanding* (pp. 19–32). Mahwah, N. J.: Lawrence Erlbaum Associates.

- Castro, A. M. (2006). Preparing elementary preservice teachers to use mathematics Curriculum Materials. *The Mathematics Educator*, 16(2), 14–24.
- Chinnappan, M., & Lawson, M. J. (2005). A framework for analysis of teachers' geometric content knowledge and geometric knowledge for teaching. *Journal of Mathematics Teacher Education*, 8(3), 197–221.
- Clements, D. H. (1998) Geometric and spatial thinking in young children.
- Chaiklin, S. (1986). Constructing productions and producing constructions. *The American Psychologist*, 41(5), 590–593.
- Chapman, O. (2004). Facilitating peer interactions in learning mathematics: Teachers' practical knowledge. In M.J. Høines & A. B. Fuglestad (Eds.), *Proceedings of the 28th PME International Conference*, 2, 191–198.
- Charmaz, K. (2000). Grounded theory: Objectivist and constructivist methods. In M. K. Denzin & Y. S. Lincoln (Eds.), *Handbook of qualitative research* (2nd ed.). (pp. 93–125). New York: Cambridge University Press.
- Charmaz, K. (2002). Qualitative interviewing and grounded theory analysis. In J. F. Coleman, J. S., Campbell, E. Q., Hobson, C. J., McPartland, J., Mood, A. M., Weinfeld, F. D., et al. (1966). *Equality of educational opportunity*. Washington, D.C.: U.S. Government Printing Office.
- Choi, H. J. (2013). *Elementary school parents' dependence on private education*. (Unpublished master's thesis). KyungSangUniversity, The Republic of Korea.
- Cobb, P., & Jackson, K. (2011). Assessing the quality of the common core state standards for mathematics. *Educational Researcher*, 40, 183–185.

- Common Core State Standards Mathematics Initiative. (2010). *Common core state standards: Application of common core state standards for English language learners*. <http://www.corestandards.org>. Accessed 6 June 2010.
- Common Core State Standards (2010). Common Core State Standards for Mathematics. http://www.corestandards.org/assets/CCSSI_Math%20Standards.pdf/. Accessed 9 September 2012.
- Conference Board of the Mathematical Sciences. (2001). The mathematical education of teachers. *American Mathematical Society*. Providence. RI.
http://www.cbmsweb.org/MET_Documnet/index.htm Accessed 5 October 2011.
- Conn. V. S., Valentine, J. C., Copper, H. M. & Rantz, M. J. (2003). Grey literature in meta-analyses. *Nursing Research*, 52, 256–261.
- Courant, R. (1996). *What is mathematics? An elementary approach to ideas and methods*. London, New York: Oxford university press.
- Crawford, M., & Witee, M. (1999). Strategies for mathematics: Teaching in context. *Educational Leadership*, 57. 34–38.
- Cresswell, J. W. (1998). *Qualitative inquiry and research design: Choosing among five traditions*. Thousand Oaks, CA: Sage.
- Darling Hammond, L. (2000). Teacher quality and student achievement: A Review of state policy evidence. *Education Policy Analysis Archives*, 8(1).
- Dee, T. S., & Jacob, B. (2011). The impact of no child left behind on student achievement. *Journal of Policy Analysis and Management*, 30, 418.

- Desimone, L. M. (2009). Improving impact studies of teachers' professional development: Toward better conceptualization and measures. *Educational Researcher*, 38(3), 181–199.
- Delaney, S., Ball, D. L., Hill, H. C., Schilling, S. G., & Zopf, D. (2008). Mathematical knowledge for teaching: Adapting U.S. measures for use in Ireland. *Journal of Mathematics Teacher Education*, 11(3), 171–197.
- Dewey, J. (1938). *Experience and education*. New York: Collier.
- Donovan, M. S., & Bransford, J. (2005). *How students learn: Mathematics in the classroom*. Washington: National Academies Press.
- Dore, R. (1976). *The diploma disease: Education, qualification, and development*. Berkeley: University of California Press.
- Eisenhart, M., Borko, H., Underhill, R., Brown, C., Jones, D., & Agard, P. (1993). Conceptual knowledge falls through the cracks: Complicities of learning to teach mathematics for understanding. *Journal for Research in Mathematics Education*, (24)1, 8–40.
- Ecksten, H. (2002). Case study and theory in political science. In Roger Gomm, Martyn Hammersley, & Peter Foster (Eds.), *Case Study Method: Key Issues, Key Text* (pp. 119–163). London: Sage Publications.
- Eisenhart, M., Borko, H., Underhill, R., Brown, C., Jones, D., & Agard, P. (2012). Conceptual knowledge falls through the cracks: Complexities of learning to teach mathematics for understanding. *Journal for Research in Mathematics Education*, (24)1, 8–40.

- Empson, S. B., & Junk, D. L. (2004). Teacher's knowledge of children's mathematics after implementing a student-centered curriculum. *Journal of Mathematics Teacher Education*, 7, 121–144.
- Erickson, F. (1986). Qualitative methods in research on teaching. In M. C. Wittrock (Ed.), *Handbook of research on teaching* (3rd ed., pp. 119–161). New York: Macmillan Publishing Company.
- Erickson, F. (2008). Students' experience of school curriculum: The everyday circumstances of granting and withholding assent to learn. In F. M. Connelly (Ed.), *The sage handbook* (pp. 198–218) Sage Publication.
- Even, R. (1993). Subject matter knowledge and pedagogical content knowledge: Prospective secondary teachers and the function concepts. *Journal for Research in Mathematics Education*, 24, 94–116.
- Even, R., & Markovits, Z. (1991). Teachers' pedagogical knowledge: The case of functions. In F. Furinghetti (Ed.), *Proceedings of the 15th PME International Conference*, 2, 40–47.
- Fennema, E., Carpenter, T. P., & Peterson, P. L. (1989). Learning mathematics with understanding: Cognitively guided instruction. In J. E. Brophy (Ed.), *Advances in research on teaching* (Vol. 1, pp. 195–221). Greenwich, CT: JAI Press.
- Fennema, E., & Franke, M. (1992). *Teachers' knowledge and its impact in*: D.A. Grouws (Ed) *Handbook of Research on Mathematics Teaching and Learning*. New York: Macmillan Publishing.
- Fennema, E., & Romberg, T. (1999). *Mathematics classrooms that promote understanding*. Mahwah, NJ: Lawrence Erlbaum.

- Fenstermacher, G., & Richardson, V. (2005). On marking determinations of quality teaching. *Teachers College Record*, *107*(1), 186–213.
- Fernyhough, C. (2008). Getting Vygotskian about theory of mind: Mediation, dialogue, and the development of social understanding. *Developmental Review*, *28*, 225–262.
- Fowles, R. (1996). Wage inequality and criminal activity: An extreme bounds analysis for the united states, 1975–1990. *Criminology*, *34*(2).
- French, W. (1949). How can the experience-centered curriculum be developed? *NASSP Bulletin*, *33*(163), 42–42.
- Gadanidis, G., Hughes, J., & Cordy, M. (2011). Mathematics for gifted students in an arts- and technology-rich setting. *Journal for the Education of the Gifted*, *34*(3), 397–433.
- Gall, M. D., Borg, W. R., & Gall, J. P. (1996) *Educational Research: An Introduction* (6th ed.). White Plains, NY: Logman.
- Gearhart, M. (2007). Mathematics knowledge for Teaching: Questions about Constructs. *Measurement: Interdisciplinary Research and Perspectives*, *5*(2), 173–180.
- Geertz, C. (1983). Blurred genres: The reconfiguration of social thought. In C. Geertz, *Local knowledge: Further essays in interpretive anthropology* (pp.19–35). New York: Harper Collins.
- Glaser, B. G., & Strauss, A. L. (1967). *The discovery of grounded theory: Strategies for qualitative research*. Chicago: Aldine.
- Golbeck, S. L., & Ginsburg, H. P. (Eds.). (2004). Early Learning in mathematics and science [Special Issue]. *Early Childhood Research Quarterly*, *19*.

- Graham, K. J. (2001). Principles and standards for school mathematics and teacher education: Preparing and empowering teachers. *School Science and Mathematics*, 101(6), 319–327.
- Graham, C., Burgoyne, N., Cantrell, P., Smith, L., Clair, L., & Harris, R. (2009). TPACK development in science teaching: Measuring the TPACK confidence of inservice science teachers. *Tech Trends*, 53(5), 70–79.
- Grossman, P. L., & Richert, A. E. (1988). Unacknowledged knowledge growth: A re-examination of the effects of teacher education. *Teaching and Teacher Education*, 4(1), 53–62.
- Grossman, P. L., Wilson, S. M., & Shulman, L. S. (1989). Teachers of substance: Subject matter knowledge for teaching. In M. Reynolds (Ed.), *The Knowledge Base for Beginning Teachers* (pp. 23–36). New York: Pergamon.
- Grouws, D. & Schultz, K. (1996). *Mathematics teacher education in:* J. Sikula (Ed) Handbook of Research On Teacher Education, 2nd edition (USA: Macmillan).
- Gubrium & J. A. Holstein (Eds.), *Handbook of interview research: Context and method* (pp. 675–694). Thousand Oaks, CA: Sage.
- Hanushek, E. A. (1998). Conclusions and controversies about the effectiveness of school resources. *Economic Policy Review Federal Reserve Bank of New York*, 4(1), 11–27.
- Hasty, C. G. (1949). In defense of formal subjects: Subject-centered curriculum. *The Clearing House*, 23(9), 527-528.
- Hardie, C. D. (1942). *Truth and fallacy in educational theory*. Cambridge Eng. The University Press.

- Hwang, H. J., & Han, H. S. (2012). Current National Mathematics Curriculum. In Kim, J., Han, I, Park, M., & Lee, J. K. (Ed.), *Mathematics Education in Korea* (pp. 21–42) World Scientific Publishing Co.
- Hiebert, J., & Carpenter, T. P. (1992). Learning and teaching with understanding. In D.A. Grouws (Ed.), *Handbook of research on mathematics teaching and learning* (pp.65–97). New York: Macmillan Publishing Company.
- Hiebert, J., Carpenter, T. P., Fennema, E., Fuson, K. C., Wearne, D., Murray, H., Olivier, A., & Human, P. (1998). Making sense: Teaching and learning mathematics with understanding. Portsmouth, NH: Heinemann.
- Hill, H. C. (2004). Professional development standards and practices in elementary school mathematics. *Elementary School Journal*, 104, 345–363.
- Hill, H. C. (2008). Mathematical knowledge for teaching and the mathematical quality of instruction: An exploratory study. *Cognition and Instruction*, 430–511.
- Hill, H. C. (2010). The nature and predictors of elementary teachers' mathematical knowledge for teaching. *Journal for Research in Mathematics Education*, Vol. 41(5), 513–545.
- Hill, H. C., & Ball, D. L. (2005). Unpacking pedagogical content knowledge: Conceptualizing and measuring teachers' topic specific knowledge of students. *Journal for research in Mathematics Education*. 372–400.
- Hill, H. C, Ball, D. L & Schilling, S. G. (2004). Developing measures of teachers' mathematics knowledge for teaching. *Elementary School Journal*, 105, 11–30.

- Hill, H. C., Ball, D. L. & Schilling, S. G. (2008). Unpacking Pedagogical Content Knowledge: Conceptualizing and Measuring Teachers' Topic-Specific Knowledge of Students. *Journal for Research in Mathematics Education*. 39(4), 372–400.
- Hill, D. M., & Barth, M. (2004). NCLB and teacher retention: Who will turn out the light? *Education and the law*. Vol. 16(2). 173–181.
- Hill, H. C., Blunk, M. L., Charalambos, Y., Lewis, J. M., Phelps, G. C., Sleep, L. & Ball, D. L. (2008). Mathematical knowledge for teaching and the mathematical quality of instruction: An exploratory study. *Cognition and Instruction*, Vol. 26(4), 430–511.
- Hill, H. C., Schilling, S. G., & Ball, D. L. (2004). Developing measures of teachers' mathematics knowledge for teaching. *The Elementary School Journal*, Vol. 105(1), 11–30.
- Hill, H. C., Rowan, B. & Ball, D. L. (2005). Effects of teachers' mathematical knowledge for teaching on student achievement. *American Educational Research Journal*, 42(2), 371–406.
- Hough, S., Bill, J., Moon, K., Guzman, M. & Lager, C. (2010). Measuring the differences in prospective elementary teachers' and secondary teachers' early pedagogical content knowledge using video cases. *Proceedings of Society for Information Technology & Teacher Education International Conference*, Chesapeake, VA: AACE., In D. Gibson & B. Dodge (Eds.). pp. 3456–3467.
- International Association for the Evaluation of Education Achievement. (1987). The underachieving curriculum. Assessing U.S. school mathematics from an international perspective. Champaign, IL: Stripes Publishing Company.

- Izsák, A. (2008). Mathematical knowledge for teaching fraction ,multiplication. *Cognition and Instruction, 26*, 95–143.
- Jang, S. J. & Tsai, M. F. (2012). Exploring the TPACK of Taiwanese elementary mathematics and science teachers with respect to use of interactive whiteboards. *Computers & Education. 59*, 327–338.
- Kahan, J. A., Cooper , D. A., & Betha, K. A. (2003). The role of mathematics teachers' content knowledge in their teaching: A framework for research applied to a study of student teachers. *Journal of Mathematics Teacher Education, 6*, 223–252.
- Kameenui, E., & Carnine, D. W. (2011). *Effective teaching strategies that accommodate diverse learners*. Upper Saddle River, N. J.: Pearson Education.
- Kanter, D. (2010). The impact of a project-based science curriculum on minority student achievement, attitudes, and careers: The effects of teacher content and pedagogical content knowledge and inquiry-based practices.(report). *Science Education, 94*(5).
- KEDI. (2012). The change of the proportion of female teachers from 1990 to 2011. <http://edpolicy.kedi.re.kr/EpnicDb/Epnic/EpnicDb01Viw.php?ContCate=B0080602&LstNum1=2869>. Accessed 4 September 2012.
- Kennedy, M. M., Ball , D. L., & McDiarmid, G. W. (1993). *A study package for examining and tracking changes in teachers' knowledge*. East Lansing, MI: The National Center for Research on Teacher Education/Michigan State University.
- Kılıç, H. (2011). Preservice secondary mathematics teachers' knowledge of students, *Turkish Online Journal of Qualitative Inquiry, 2*(2), 17–36.
- Kilpatrick, J., Swafford, J., & Findell, B. (Eds.). (2001). *Adding it up: Helping children learn mathematics*. Washington: National Academy Press.

- Kim. (2012). Survey on the first students' prior learning experiences in South Korea. http://www.hani.co.kr/arti/society/society_general/602288.html. Accessed 8 September 2013.
- Kim, R. Y., Ham, S. H., & Paine, L. W. (2011), Knowledge expectations in mathematics teacher preparation programs in South Korea and the United States: Towards International Dialogue. *Journal of Teacher Education*. 62(1), 48–61.
- Kinach, B.M. (2002). A cognitive strategy for developing pedagogical content knowledge in the secondary mathematics methods course: toward a model of effective practice. *Teaching and Teacher Education*, 18, 51–71.
- Klein, R., & Tirosh, D. (1997). Teachers' pedagogical content knowledge of multiplication and division of rational numbers. In H. Pekhonen (Ed.), *Proceedings of the 21st PME International Conference*, 3, 144–152.
- Kleve, B. (2010). Contingent moments in a lesson on fractions. *Research in Mathematics Education*, 12(2), 157–158.
- Kliebard, H. (1995). *The struggle for the American curriculum, 1893–1958*. New York: Routledge.
- Konstantopoulos, S. (2011). Teacher effects in early grades: Evidence from a randomized study. *Teachers College Record*, 113.
- Kulm, G., & Li, Y. (2009). Curriculum research to improve teaching and learning: national and cross-national studies. *ZDM Mathematics Education*. 41, 709–715.
- Labaree, D. F. (2008). An uneasy relationship: The history of teacher education in the university. In M. Cochran-Smith, S. Feiman-Nemser, & J. McIntyre (Eds.),

- Handbook of research on teacher education (3rd ed., pp. 290–306). New York: Routledge.
- Ladson-Billings, G., & Brown, K. (2008). Curriculum and cultural diversity. In F. M. Connelly (Ed.), *The sage handbook* (pp. 153–175) Sage Publication.
- Lagemann, E. C. (2000). *An elusive science: The troubling history of education research*. Chicago: University of Chicago Press.
- Lampert, M. (2001). *Teaching problems and the problems of teaching*. New Haven, Conn.: Yale University Press.
- Lee, J. (1999). Historic factors affecting educational administration in Korean higher education. *Higher Education Review*, 32(1), 7–23.
- Leinhardt, G. (1993). On teaching. In R. Glaser (Ed.), *Advances in instructional psychology* (4, pp.1–54). Hillsdale, NJ: Lawrence Erlbaum Associates, Inc.
- Levin, B. (2008). Curriculum policy and the politics of what should be learned in schools. In F. M. Connelly (Ed.), *The sage handbook* (pp. 7–24) Sage Publication.
- Li, Y., & Huang, R. (2008). Chinese elementary mathematics teachers' knowledge in mathematics and pedagogy for teaching: the case of fraction division. *Mathematics Education*. 40, 845–859.
- Lloyd, G. M. (2008). Curriculum use while learning to teach: One student teacher's appropriation of mathematics curriculum materials. *Journal for Research in Mathematics Education*, 39(1), 63–94.
- Ma, L. (Ed.). (2010). *Knowing and teaching elementary mathematics teachers' understanding of fundamental mathematics in china and the United States*. ebrary, Inc. Milton Park, Abingdon, Oxon; New York: Routledge.

- Maloney, E. A., Risko, E. F., Ansari, D., & Fugelsang, J. (2010). Mathematics anxiety affects counting but not sanitizing during visual enumeration. *Cognition, Vol. 114(2)* 293–7
- Margolinas, C., Coulange, L., & Bessot, A. (2005). What can the teacher learn in the classroom? *Educational Studies in Mathematics, 59*, 205–234.
- Margolis, E., & Laurence, S. (1999). *Concepts: Core readings*. Cambridge, Mass.: MIT Press.
- Marks, R. (1990). Pedagogical content knowledge: From a mathematical case to a modified conception. *Journal of Teacher Education, 41(3)*. 3–11.
- Marsh, C. (1990). *Reconceptualizing school-based curriculum*. London; New York; Philadelphia: Falmer Press.
- Marx, K., & Engels, F. (Ed.). (1962). *Wage labor and capital in selected works*. New York: International Publishers.
- McEwan, H. and Bull, B. (1991). The pedagogic nature of subject matter knowledge. *American Educational Research Journal, 28*, 316–334.
- McLellan, J. A., & Dewey, J. (1895). *The psychology of number and its applications to methods of teaching arithmetic*. New York: D. Appleton.
- McNamara, D. (1991) ‘Subject knowledge and its application: problems and possibilities for teacher educators.’ *Journal of Education for Teaching, 17(2)*, 113–128.
- Meredith, A. (1993) Knowledge for teaching mathematics: Some student teachers’ views. *Journal of Education for Teaching, 19(3)*, 325–338.
- Meredith, A. (1995) Terry’s learning: Some limitations of Shulman’s pedagogical content knowledge. *Cambridge Journal of Education, 25(2)*, 175–187.

- Miles, M. B., & Huberman, A. M. (1994). *Qualitative data analysis: An expanded sourcebook* (2nd ed.). Thousand Oaks, CA: Sage.
- Min, B. B. (1998). *5, 6 차교육과정의변화에따른직업관과과학과관련된태도연구 : 일반계 여자고등학교 학생을 중심으로*. Unpublished 한국외국어대학교, The Republic of Korea.
- Mishra, P., & Koehler, M. J. (2006). Technological pedagogical content knowledge: A new framework for teacher knowledge. *Teacher College Record*, *108*(6), 1017–1054.
- Moon, S. S. & Kwan, J. S. (2006). 교육과정변화에따른 과학의 본성에 대한 고등학생 관점 변화. *한국과학교육학회*, (제 1 호), 58–67.
- Morris, A. K., Hiebert, J., & Spitzer, S. M. (2009). Mathematical knowledge for teaching in planning and evaluating instruction: What can preservice teachers learn? *Journal for Research in Mathematics Education*, *40*, 491–529.
- Morton, M. (2011). Learning together: Collaboration to develop curriculum assessment that promotes belonging. *Support for Learning*, *26*(3), 109.
- Moschkovich, J. (2002). A Situated and Sociocultural Perspective on Bilingual Mathematics Learners. *Mathematics Thinking and Learning*, *4*. 189–212.
- Nakamura, T. (2005). Educational system and parental education fever in contemporary Japan: Comparison with the case of South Korea. *KEDI Journal of Educational Policy*, *2*(1), 35–49.
- National Commission on Excellence in Education. (1983). *A nation at risk. The imperative for education reform*. U.S. Government Printing Office.

- National Council of Teachers of Mathematics. (2000). *Principles and Standards for school mathematics*. Reston: VA.
- National Council of Teachers of Mathematics. (1991). *Professional standards for teaching mathematics*. Reston: VA.
- National Research Council. (2002). *Scientific research in education*. Washington, D.C.: National Academy Press.
- Needels, M. C. (1988). A New Design for Process-Product Research on the Quality of Discourse in Teaching. *American Educational Research Journal*, 25(4), 503–526.
- Ng, D. (2011). Indonesian primary teachers' mathematical knowledge for teaching geometry: Implications for educational policy and teacher preparation programs. *Asia-Pacific Journal of Teacher Education*, Vol. 39(2), 151–164.
- Niess, M. L. (2005). Preparing teachers to teach science and mathematics with technology: developing a technology pedagogical content knowledge. *Teaching and Teacher Education*, 21(5), 509–523.
- Nietro, S., Bode, P., Kang, E., & Raible, J. (2008). Identity, community and diversity: Retheorizing multicultural curriculum for the postmodern era. In F. M. Connelly (Ed.), *The sage handbook* (pp. 176–197) Sage Publications.
- Park, K. (2010). Mathematics teacher education in Korea. In Koon, F., Leung, S., & Li, Y. (Eds.), *Reforms and issues in school mathematics in East Asia: Sharing and understanding mathematics education policies and practices* (pp. 181–196). Chesapeake, VA: AACE.

- Parker, J & Heywood, D. (2000). Exploring the relationship between subject knowledge and pedagogic content knowledge in primary teachers' learning about forces. *International Journal of Science Education*, 22(1), 89–111.
- Peterson, P. L, Fennema, E., & Carpenter, T. P. (1991). Teachers' knowledge of students' mathematical problem-solving knowledge. In J. E. Brophy (Ed.), *Advances in research on teaching* (2, pp. 49–86). Greenwich, CT: JAI Press.
- Peterson, P., Woessmann, L., Hanushek, E. A., & Lastra-Anadón, C.X. (2011). Globally challenged: Are U.S. students ready to compete? Harvard's Program on Education Policy & Governance (PEPG). <http://hks.harvard.edu/pepg>. Accessed 19 February 2012.
- Popkewitz, T. (1977). The latent values of the discipline-centered curriculum. *Theory and Research in Social Education. School-based curriculum development / centre for educational research and innovation (CERI)*.
- Polly, D. (2011). Developing teachers' technological, pedagogical, and content knowledge (TPACK) through mathematics professional development. *International Journal for Technology in Mathematics Education*, 18(2), 83–95.
- Polly, D., McGee, J. R., & Martin, C. S. (2010). Employing technology-rich mathematical task in professional development to develop teachers' technological, pedagogical, and content knowledge (TPACK). *Jl. Of Computers in Mathematics and Science Teaching*. 29(4), 455–472.
- Polya. G. (1957). *How to solve it* (2nd ed.). Garden City, NY: Doubleday Anchor Books.
- Pólya, G. (Ed.). (1985). *How to solve it: A new aspect of mathematical method*. Princeton University Press: N.J.

- Porter, A., McMaken, J., Hwang, J., & Yang, R. (2012). Common Core Standards: The new U.S. intended curriculum. *Educational Researcher*, 40(3), 103–116.
- Ponde, J. P. D., & Chapman, O. (2007). Mathematics Teachers' Knowledge and Practice. In Gutierrez, A. & Boero, P. (Eds.), *Handbook of Research on the Psychology of Mathematics Education*, 461–494.
- Putnam, R. T., & Borko, H. (1996). Learning to teach. In R. T. Putnam, (Ed.). *Handbook of educational psychology*. New York: Macmillan.
- Rahman, F. A., Scaife, J., Yahya, N. A., & Jalil, H. A. (2010). Knowledge of diverse learners: Implications for the practice of teaching. *International Journal of Instruction*, 3(2), 83–96.
- Ragin, C. (1997). Turning the tables: How case-oriented research challenges variable-oriented research. *Comparative Social Research*, 16, 27–42.
- Robinson, N., Even, R., & Tirosh, D. (1992). Connectedness in teaching algebra: A novice-expert contrast. In W. Geeslin & K. Graham (Eds.), *Proceedings of the 16th PME International Conference*, 2, 258–263.
- Robinson, N., Even, R., & Tirosh, D. (1994). How teachers deal with their students' conceptions of algebraic expressions as incomplete. In J. P. Ponte & J. F. Matos (Eds.), *Proceedings of the 18th PME International Conference*, 4, 129–136.
- Rossmann, G. B., & Rallis, S. F. (2003). *Learning in the field: An introduction to qualitative research* (3rd ed.). Thousand Oaks, CA: Sage.
- Rowland, T., Huckstep, P., & Thwaites, A. (2005). Elementary teachers' mathematics subject knowledge: The knowledge quartet and the case of Naomi. *Journal of Mathematics Teacher Education*, 8(3), 255–281.

- Richards, J. & T. Farrell (2005). Professional development for language teachers: Strategies for teacher learning. Cambridge: Cambridge University Press.
- Rice, J. K. (2003). In Washington D. (Ed.), *Teacher quality: Understanding the effectiveness of teacher attributes*. Economic Policy Institute.
- Rivers, J. C., & Sanders, W. L. (2002). Teacher quality and equity in education opportunity: Findings and policy implications. *Teacher quality* (In L. T. Izumi & M. E. Williamson (Eds.) ed., pp. 13–23). Hoover Press: Stanford, CA.
- Rossmann, G.B., & Rallis, S.F. (2003). *Learning in the Field: An Introduction to Qualitative Research, 3rd edition*. Thousand Oaks, CA: SAGE Publications.
- Rowland, T., P. Huckstep, P., & Thwaites, A. (2005). Elementary teachers' mathematics subject knowledge: The knowledge quartet and the case of Naomi. *Journal of Mathematics Teacher Education*, 3 255–281.
- Rudman, P. (2007). How mathematics happened: The first 50,000. *Choice Reviews Online*. 45(5), pp. 45-2662–45-2662.
- Santibañez, L. (2005). Why we should care if teachers get A's: Teacher test scores and student achievement in Mexico. *Economics of Education Review*. 25 510–520.
- Sarton, G. (1935). The first explanation of decimal fractions and measures (1585). Together with a history of the decimal idea and a facsimile (No. XVII) of Stevin's Disme. *Isis*. 23(1): 153–244.
- Scher, L., & O'Reilly, F. (2009). Professional development for K-12 math and science teachers: What do we really know? *Journal of Research on Educational Effectiveness*, 2, 209–249.

- Schmidt, D. A., Baran, E., Thompson, A. D., Mishra, P., Koehler, M. J., & Shin, T. S. (2009). Technological pedagogical content knowledge (TPACK): The development and validation of an assessment instrument for preservice teachers. *Journal of Research on Technology in Education*, 42(2), 123–149.
- Schwab, J. J. (1964). *The structure of the disciplines: Meanings and significances*. In: G.W. Ford and L. Pugno, Editors, *The structure of knowledge and the curriculum*, Rand McNally, Chicago. pp. 6–30.
- Segall, A. (2004) Revisiting pedagogical content knowledge: The pedagogy of content/the content of pedagogy. *Teaching and Teacher Education* 20, 489–504.
- Selwyn, D. (2007). Highly quantified teachers: NCLB and teacher education. *Journal of teacher education*. 58(2). 124–237.
- Seoul Metropolitan Office of Education. (2013). Survey on education in Seoul. http://www.sen.go.kr/web/services/page/viewPage.action?page=kor/info/info_06_02_12_01.html. Accessed 8 September 2013.
- Seth, M. (2002). *Education fever: Society, politics, the pursuit of schooling in South Korea*. Hawaii: University of Hawaii Press.
- Sherin, M. (2009). Curriculum strategy framework: Investigating patterns in teachers' use of a reform-based elementary mathematics curriculum. *Journal of Curriculum Studies*, 41(4), 34–34.
- Shulman, L. S. (1986). Paradigms and research programs in the study of teaching: A contemporary perspective. In M. C. Wittrock (Ed.), *Handbook of Research on Teaching* (3rd edition, pp. 3–36). New York: Macmillan Publishing Company.

- Shulman, L. (1987). Knowledge and teaching: Foundations of the new reform. *Harvard Educational Review*, 57(1), 1–22.
- Shulman, L. (1992). Ways of seeing, ways of knowing, ways of teaching, ways of learning about teaching. *Journal of Curriculum Studies*, 28, 393–396.
- Smith, M. S., & Stein, M. K. (2011). 5 practices for orchestrating productive Mathematics Discussions. Reston, VA: National Council of Teachers of Mathematics; Thousand Oaks, CA: Corwin.
- Skemp, R. R. (1989). *Mathematics in the primary school*. London: Routledge.
- Sorensen, C. (1994). Success and education in South Korea. *Comparative Education Review*, 38(1), 10–35.
- Stake, R. E. (1995). *The art of case study research*. Thousand Oaks, London, New Delhi: Sage.
- Stake, R. E. (2000). Case studies. In N. K. Denzin & Y. S. Lincoln (Eds.), *Handbook of qualitative research* (2nd ed. pp. 435–454). Thousand Oaks, CA: Sage.
- Steele, D. F. (2001). Using sociocultural theory to teach mathematics: A Vygotskian perspective. *School Science and Mathematics*. 101(8), 404–416.
- Stigler, J. W., Fernandez, C., & Yoshida, M. (1996). Traditions of school mathematics in Japanese and American elementary schools. In L. P. Steffe, P. Nesher, P. Cobb, G. A. Goldin, & B. Greer (Eds.), *Theories of mathematics learning* (pp. 149–177). Hillsdale, NJ: Lawrence Erlbaum Associates, Inc.
- Stones, E. (1992) *Quality Teaching: A sample of cases*. London: Routledge.

- Strauss, A., & Corbin, J. (1994). Grounded theory methodology: An overview. In N. Denzin & Y. Lincoln (Eds.), *Handbook of qualitative research*. Thousand Oaks, CA: Sage.
- Stretton, H. (1969). *The Political Sciences: General principles of selection in social science and history*. London: Routledge & Kegan Paul.
- Stylianides, A. J., & Ball, D. L. (2008). Understanding and describing mathematical knowledge for teaching: Knowledge about proof for engaging students in the activity of proving. *Journal of Mathematics Teacher Education*, *11*, 307–332.
- Tanase, M. (2011). Teaching place value concepts to first grade Romanian students: Teacher knowledge and its influence on student learning. *International Journal for Mathematics Teaching and Learning*.
- The Ministry of Education. (2007). The National Mathematics Curriculum.
<http://cutis.mest.go.kr/main.jsp?gCd=S02&siteCmsCd=CM0001>. Accessed 4 September 2013.
- The Ministry of Education. (2007). *National teachers' guidebook for 6th grade*. South Korea; The Ministry of Education.
- The Ministry of Education. (2011). The National Common Basic Curriculum.
<http://cutis.mest.go.kr/main.jsp?gCd=S02&siteCmsCd=CM0001>. Accessed 4 September 2013.
- The Ministry of Education in South Korea. (2013). The educational history of South Korea. from <http://www.mest.go.kr>. Accessed March 28, 2013.

- The Seoul National University of Education. (2012). *The Seoul National University of Education: College bulletin*. Seoul: The Seoul National University of Education Press.
- Thornton, C. A., & Others. (1997). Mathematics instruction for elementary students with learning disabilities. *Journal of Learning Disabilities, Vol. 30(2)*, 142–50.
- Turner, F. (2008). Beginning elementary teachers' use of representations in mathematics teaching. *Research in Mathematics Education, Vol. 10(2)*, 209–210.
- Turnuklu, E., & Yesildere, S. (2007). The pedagogical content knowledge in mathematics: Pre-Service primary mathematics teachers' perspective in Turkey. *IUMPST: The Journal. Vol. 1*, 1–13.
- U.S. Department of Education, Office of Postsecondary Education, & Office of Policy Planning and Innovation (Ed.). (2002). *Meeting the highly qualified teachers challenge: The secretary's annual report on teacher quality*; Washington, D.C.
- Vygotskiĭ, L.V. (1978). *Mind in society: The development of higher psychological processes*. Cambridge: Harvard University Press.
- Vygotsky, L. S. (1981). The development of higher forms of attention in childhood. In J. V. Wertsch (Ed.), *The concept of activity in Soviet psychology*. Armonk, N.Y.: Sharpe.
- Vygotsky, L. S. (1997). Genesis of higher mental functions. In R. W. Rieber (Ed.). *The collected works of L. S. Vygotsky (Vol. 4)*. New York: Plenum (Original work published 1931).
- Wertheimer, M. (1959). *Productive thinking*. New York: Harper & Row.

- Wertsch, J.V. (1985a), *Culture, Communication and Cognition: Vygotskian Perspectives*, Cambridge: Cambridge University Press.
- Wertsch, J. V. (1985b). *Vygotsky and the social formation of mind*. Cambridge, MA: Harvard University Press.
- Westbury, I. (2008). Making curricula: Why do states make curricula, and how? In F. M. Connelly (Ed.), *The sage handbook* (pp. 45–65) Sage Publications.
- Wilson, S., Shulman, L., & Richert, A. (1987). "150 different ways of knowing": Representations of knowledge in teaching. In J. Calderhead (Ed.), *Exploring teachers' thinking* (pp. 104-123). Eastbourne, England: Cassell.
- Wiseman, D. L., Cooner, D. D., & Knight, S. L. (1999). *Becoming a teacher in a field-based setting*. New York: Wadsworth.
- Wolcott, H. F. (1994). *Transforming qualitative data: Description, analysis, and interpretation*. Thousand Oaks, CA: Sage.
- Wolf, M. (1972). *Women and the family in rural Taiwan* Stanford UP.
- Yin, R. K. (1994). *Case study research design and methods. Applied Social Research Methods Series* (2nd ed.). Sage.
- Yu, J. (2011). The Confucian legacy and its implications for physical education in Taiwan. *European Physical Education Review*, 17(2), 12–12.
- 강신표. (1981). 과열과외의사회문화적배경. In 한국교육개발원 (Ed.), *한국교육발전방향탐색* (pp. 58-69) 한국교육발전방향탐색.
- 강창동. (1966). 한국가족주의의교육문화적성격. *교육사회학연구*, 제 6 권(1 호), 1-16.

- 강창일. (2002). 친일파의 형성과 친일의 논리. *학술단체협의회 2002년도 정책토론회, 한국 근현대속의 친일의 의미와 친일파 청산운동의 필요성*. The Republic of Korea.
- 김경근. (1996). 한국사회의 인구학적 변동과 그 배경: 경제발전과 교육열의 영향을 중심으로 *교육사회학연구*, 6 권(1 호), 33-50.
- 김광익. (1994). 문화공동체와 지방정치; 씨족의 구조를 중심으로. [Cultural Community and Local Politics] *한국문화인류학*, 25, 116-182.
- 김진희&이상록. (2011). 빈곤, 주거환경, 이웃환경과 청소년 발달의 구조적 관계. [Structural Relationships of Poverty, Residential Environment, Neighborhood Environment and Adolescence's Development] *청소년학연구*, 제 18 권(제 5 호), 385-411.
- 김혜숙, 한., & 오경희. (2011). 중학생의 사교육 의존 의식과 문화에 관한 질적 연구. [A Qualitative Study on Middle School Students' Dependence on sciousness] *열린교육연구*, 제 19 권(제 1 호), 127-147.
- 곽병선(1993). 한국인의 교육열: 교육학적 고찰, *교육진흥*, 5 권 4 호, 102-109.
- 박부진. (1994). *한국 농촌 가족의 문화적 의미와 가족관계의 변화에 관한 연구*. (Unpublished doctoral dissertation). 서울대학교, The Republic of Korea.

- 박혜인(1994). *한국가족의 교육열에 대한 역사적 고찰: 과거시험이 가족, 사회에 미친 영향을 중심으로*. In 한국가족학연구회. 자녀교육열과 대학입시. 하우.
- 반민족문제연구소편. (1993). *천일과 99 인*. The Republic of Korea: 돌베개.
- 반민족문제연구소편. (1994). *청산하지못한역사*. The Republic of Korea: 청년사.
- 손호철. (1995). *해방 50 년의한국정치*. The Republic of Korea: 새길.
- 송광성. (1993). *미군점령 4 년사*. The Republic of Korea: 한울.
- 이명화. (2011). 일제강제합병이테올로기와식민교육. *한국독립사연구학회지, Vol. 39*, 77-126.
- 이종각(1997). *교육인류학 탐색*. The Republic of Korea: 하우.
- 이종각. (1998). 교육열과 교육관의 불쌍함과 구제책에 대하여. *교육인류학회소식, 제 4 권(제 2 호)*, 1-3.
- 이중권. (2004). *우리나라의 수학교육과정*. 대한민국; 경문사.
- 인천상공회의소. (2012). *인천인력수급현황보고서*. The Republic of Korea.
- 임천순. (1997). 한국직업교육정책의접근과쟁점. *교육재정경제연구*, 447-503.

정준영. (2011). 식민지교육정책의원점:

이자와슈지의동화주의와청각적근대성. *정신문화연구*, Vol. 34., 153-184.

조이스콜코. (1985). *미국과한국의해방, 한국현대사의재조명*. The Republic of Korea:

돌베개.

하윤수. (2009). 미국다문화교육의동향과사회화교육과정. *사회과교육*, Vol. 48 (3),

117-132.

Appendix A:

The Review of the Empirical Studies

No.	Author (Year)	Research question	Mathematics content area	The subject from the research design
1	Anderson, H. & Kim, S. (2003).	What aspect of the knowledge based that prospective teachers develop in their teacher education program makes them a successful mathematics teacher?	Numbers and algorithms	Lessons of elementary teachers
2	Ball, D. L., Thames, M. H., & Phelps, G. (2008).	1. What do teachers need to know and be able to do in order to teach effectively? 2. What does effective teaching require in terms of content understanding?	.	Lessons of elementary teachers
3	Bell, C. A., Wilson, S., Higgins, T., & McCoach, D. B. (2010).	Is there a relationship between teacher experience and teachers' mathematical knowledge?	Number and Algorithms	Elementary teachers test scores about mathematical knowledge and teacher experience
4	Cai, J. (2005).	What is the difference between Chinese and U.S. elementary teachers regarding mathematical knowledge?	Number and Algorithms	Mathematics representations that were presented on teacher's lesson plan
5	Delaney, S., Ball, D. L., Hill, H. C., Schilling, S. G. & Zopf, D. (2008).	1. What methodological challenges were encountered when attempting to use the items outside the United States? 2. What choices did we make when adopting the items and these initial explorations suggest about the suitability of the U.S. measures for studying mathematical knowledge of teachers in Ireland?	Number and Algorithms	Elementary teachers test scores on mathematical knowledge
6	Empson, S. B., & Junk, D. L. (2004).	1. What knowledge do teachers who have implemented a student-centered curriculum use to make sense of	Numbers and Algorithms	Interaction between an elementary mathematics teacher and his or her students

		<p>students' nonstandard strategies?</p> <p>2. How might teachers' acquisition of this knowledge be linked to the use of the new curriculum materials?</p>		
7	Hill, H. C. (2008).	<p>1. What is the overall strength of the relationship between teachers' MKT and the mathematical quality of their instruction?</p> <p>2. What does MKT afford instruction? How does a lack of MKT constrain instruction?</p>	Numbers and Algorithms	Elementary teachers' test scores on mathematical knowledge and elementary teachers' lessons
8	Hill, H. C. (2010).	<p>1. What does elementary teachers' performance on a paper-and pencil assessment suggest about the nature of their:</p> <p>a) knowledge within the strand of number and operations?</p> <p>b) knowledge of specific tasks of teaching</p> <p>2. Are there predictors of teachers' mathematical knowledge for teaching? (MKT)</p> <p>a. How are teachers' reports of their own educational background related to their MKT?</p> <p>b. Are those who have taken leadership positions in mathematics especially qualified in the area of mathematical content?</p> <p>c. Do alternatively certified teachers possess greater amounts of MKT?</p>	Numbers and Algorithms	Elementary teachers' test scores on mathematical knowledge and teacher experience

		3. Are students of different socioeconomic statuses assigned to teachers who have, on average, lower MKT?		
9	Hill, H. C. & Lubienski, S. T. (2007).	Is there a relationship between the teachers' mathematical knowledge and demographics of the schools?	Number and algorithms	Elementary teachers test scores on mathematical knowledge and demographics of the schools
10	Hill, H. C., Rowan, B. & Ball, D. L. (2005).	How does teachers' mathematical knowledge affect students' achievements?	Numbers and algorithms	Elementary teachers test scores on mathematical knowledge and students' mathematics test scores
11	Hill, H. C., Schilling, S. G., & Ball, D. L. (2004).	Given the structure of teachers' mathematical knowledge for teaching, can we construct scales that measure such knowledge reliably?	Numbers and algorithms	Elementary teachers' lessons
12	Izsák, A. (2006).	What mathematical knowledge did the teachers use when examining such examples for opportunities to build general numeric methods?	Numbers and algorithms	Mathematics representations that were presented in a teacher's lesson plan
13	Kleve, B. (2009).	What knowledge is required for the teaching of mathematics?	Numbers and algorithms	Interaction between an elementary mathematics teacher and his or her students
14	Kleve, B. (2010).	How do examples and illustrations of improper fractions influence the pupil's conceptions and difficulties? How are these discussed? Is consideration given to whether the problems expressed are manifested in aspects of the teacher's mathematical	Numbers and algorithms	Mathematics representations that elementary teachers use in the classroom

		knowledge?		
15	Li, Y., & Huang, R. (2008).	<p>1. What are the beliefs and perceptions of practicing elementary mathematics teachers regarding their knowledge of mathematics and pedagogy for teaching?</p> <p>2. What is the extent of practicing elementary teachers' mathematics knowledge for teaching fraction division?</p> <p>3. What differences may exist between practicing and prospective teachers in China in terms of their perceptions and mathematics knowledge for teaching?</p>	Numbers and algorithms	Elementary teachers' lessons and teachers' experience
16	Ng, D. (2011).	<p>1. How does Indonesian primary teachers' mathematical knowledge for teaching geometry correspond to the number of years of teaching experience, educational level attained, school type (public or private), range of grade levels taught, number of professional development hours completed, and number of college-level geometry courses taken?</p> <p>2. Which of the above factors contributes most to Indonesian primary teachers' mathematical knowledge for teaching geometry?</p>	.	Elementary teachers test scores about mathematical knowledge and teacher experience
17	Polly, D. (2011).	1. What influence do mathematics teachers report about the	Numbers and algorithms	Mathematics representations that were presented in

		influence of professional development on their TPACK related to their mathematics teaching? 2. In what ways do teachers implement TPACK in their mathematics teaching?		teacher's lesson plan
18	Stylianides, A. J., & Ball, D. L. (2008).	How can we study this form of knowledge so that we will be able to identify elements of it that might be important for teaching?	Proof	Interaction between an elementary mathematics teacher and his or her students
19	Tanase, M. (2011).	1. What knowledge of place value concepts do the four Romanian teachers possess? 2. How does this knowledge transfer in their practice? Does teacher knowledge of content and pedagogy affect student learning?	Number and Algorithms	Interaction between an elementary mathematics teacher and mathematics representations that elementary teachers use in the classroom
20	Turner, F. (2008).	How do teachers use representations in their mathematics classroom?	Number and Algorithms	Mathematics representations that elementary teachers use in the classroom

Appendix B:
Informed Consent Form

Consent Form for Participants (English)



**Boston College Lynch School of Education
Informed Consent to be in the Study:
South Korean Elementary Teachers' Pedagogical Content Knowledge in
Mathematics
Principal Investigator: Lillie R. Albert, Ph.D.**

Introduction

You are one of eight teachers being invited to take part in a research study about the structure of South Korean elementary teachers' pedagogical content knowledge in mathematics. Professor Lillie R. Albert of Boston College and Rina Kim, who is a doctoral student at Boston College, will be conducting this study. Please read this form. Ask any questions that you may have before you agree to be in the study.

Purpose of the Study

The purpose of this research is to develop an understanding of South Korean elementary teachers' pedagogical content knowledge in mathematics. In accordance with this purpose, this research seeks to identify the mathematics knowledge for teaching at the elementary level by analyzing South Korean elementary teachers' pedagogical content knowledge in mathematics.

Procedures

If you agree to be in this study, you will be asked to participate in the following ways. First, you will be asked to write two lesson plans, which will provide background information about your teaching. There is no certain form for the lesson plans. You can develop your lesson plans, as you want. Second, there will be three one-hour interviews. In the first interview, we will ask about your teaching experiences and the process of preparing lessons. In the second interview, you will be asked to analyze students' works and answer how to teach these students base on your analysis. The third interview will contain subsequent questions of the observation of your teaching. We will audio record all interviews. Third, we will observe and video record one 40-minutes observation of your teaching. In this process, we will not video record students' faces in order to protect their identity. We also will take notes during the observation. With your permission, we will keep these transcriptions, audio and video files indefinitely in case we revisit the topic in future research projects. Furthermore, we will contact you as we begin to interpret the findings to seek your input regarding accuracy. By during so, we can ensure that the final report will be an appropriate representation of your perspectives.

Risks and Discomforts of Being in the Study

This study has the following risks, although minimal. There is a possible inconvenience of time commitment to participate in the various aspects of the study. In addition, as with any study, there may be unforeseen risks, as well.

Benefits of Being in the Study

During the process, you will have opportunities to reflect on and explore an aspect of professional development that is often overlooked. Furthermore, the topic of pedagogical content knowledge may provide an experience of self-renewal, allowing you to reflect on deep personal truths and meanings of your service as educators.

Payments

There is no payment upon your participation in this study.

Confidentiality

We will take a number of steps to protect your identity. We will keep all interview and observational data in a secure space in Professor Albert's office. Field notes will be in a locked file cabinet, while all other data (e.g. video and audio recordings) will be stored on a password protected laptop and secured in Professor Albert's office. We will be the only one to have access to any of these data sources. Furthermore, pseudonyms will be used in all analytical procedures as well as in the written report. The list of pseudonyms to identify participants will be stored in a locked file cabinet separately from all the other data materials. In addition, we will make every effort to keep your research records confidential. Access to the records will be limited to the researchers; however, please note that Boston College Institutional Review Board and internal auditors and regulatory agencies may review the research records to make sure we are following appropriate protocols and ensuring the safety of the participants.

Voluntary Participation/Withdrawal

Your participation in this study is entirely voluntary. If you choose not to participate, it will not affect your teaching position at your school or in the district. At anytime, you have the right to withdraw, for whatever reason. You may refuse to answer any question that we pose. There is not penalty for not taking part or for stopping your participation.

Dismissal From the Study

The researcher may withdraw you from the study at any time, if it is deemed in your best interest or if there is failure to comply with the study requirements.

Contacts and Questions

If you have any questions about the research project, you can contact Professor Albert by phone 01-617-552-4272 or by email at albertli@bc.edu. You may also contact the research assistant Rina Kim by phone at 070-7524-6517 or via email at rina@bc.edu. If you have any questions about your rights as a participant in this research study, or if any breach of confidentiality should occur during the course of the research you can contact: Director, Office for Research Protections, Boston College via phone at 01-617-552-4778 or email at

irb@bc.edu. You will be given a copy of this consent form to keep for your records and future reference.

I understand the above information. I have been encouraged to ask questions. I have received answers to my questions. I voluntarily consent to participate in this research. I give my permission to be audiotaped during the interviews and videotaped of my teaching. I understand that I can withdraw from this study at anytime.

Printed Name of Participant: _____

Signature of Participant: _____ Date: _____

I received a copy of the consent form for my records.

Consent Form for Participants (Korean)



Boston College Lynch School of Education
Informed Consent to be in the Study:
South Korean Elementary Teachers' Pedagogical Content Knowledge in
Mathematics
Principal Investigator: Lillie R. Albert, Ph.D.

개관

선생님께서서는 한국초등교사의 수학교수학적 지식의 구조에 관한 연구에 참여하시게 될 것입니다. 보스턴 대학의 릴리 알버트 교수님과 박사과정에 있는 김리나 선생님이 이 연구를 진행할 예정입니다. 선생님께서서는 참가에 동의하시기 전에 이 양식에 작성된 내용을 읽어보시고 궁금한 점이 있으시다면 질문해 주시기 바랍니다.

연구의 목적

본 연구는 한국초등교사의 수학교수학적 지식의 이해를 목표로 하고 있습니다. 이 목표에 따라, 본 연구에서는 한국초등교사의 수학교수학적 지식을 분석하여 초등수학교육에서 필요한 교사의 수학교수학적 지식을 규명하고자 합니다.

연구의 절차

선생님께서 이 양식에 동의하시면, 선생님께서서는 다음과 같은 절차에 따라 연구에 참여하시게 됩니다. 우선, 선생님께서서는 선생님의 수업을 이해하는 데 필요한 배경 지식을 제공할 수 있는 2 개의 지도안을 제출하셔야 합니다. 정해진 지도안의 양식은 없으며, 선생님의 임의대로 자유롭게 작성해주시면 됩니다. 다음으로 3 회로 예정된 인터뷰에 참여하셔야 합니다. 각 인터뷰는 약 1 시간 정도 소요될 예정입니다. 첫번째 인터뷰에서는 선생님의 교육경력과 수업 준비과정에 대해 질문할 예정입니다. 두번째 인터뷰에서는 학생의 학습 결과물을 분석하시고, 그 학생을 어떻게 지도할 지 답변해주시는 과정이 있을 예정입니다. 세번째 인터뷰는 선생님의 수업 참관 후 수업에 대한 질문을 중점적으로 다룰 예정입니다. 모든 인터뷰는 녹음될 것입니다. 마지막으로, 연구자가 선생님의 수학수업 (40 분)을 1 회 참관하고 이를 녹화할 것입니다. 이 때, 선생님의 학생들의 신원 보호를 위해 학생들의 모습은 촬영하지 않습니다. 또한 전 과정에 걸쳐 모든 활동들은 연구자에 의해 기록될 것입니다. 선생님의 허락 하에, 본 연구는 녹취된 음성, 영상 파일 및 수기로 기록된 자료들을 향후에 다른 연구를 위해서 사용할

수도 있습니다. 또한, 선생님의 수업 의도의 정확한 이해와 연구 결과의 정확성을 높이기 위해 향후 추가로 선생님께 연락을 드릴 수도 있습니다

연구 참여에 따른 예상되는 불이익

연구자들은 본 연구 참여에 따른 불이익을 최소화하기 위해 노력할 예정입니다. 그러나 부득이하게 다음과 같은 불이익이 발생할 수도 있습니다. 참가자는 본 연구에 참여함으로써 시간상에 불편함을 겪으실 수 있습니다. 또한 그 밖에 현재는 예측되지 않는 다른 불이익이 불가피하게 발생할 수 있습니다.

연구 참여에 따른 예상되는 이익

본 연구에 참여하시시면서, 선생님께서는 그동안 간과하셨던 교사로서의 전문성 함양에 대해 다시 돌아보고, 탐구할 기회를 가지시게 될 것입니다. 또한 교수학적 지식이라는 주제는 선생님께서 교육자로서의 신념과 교수에 대해 스스로 생각해보실 수 있는 기회를 제공할 것입니다.

수당

연구 참여에 따른 별도의 수당은 지급되지 않습니다.

신원보장

선생님의 신원을 보장하기 위해 본 연구에서는 여러 단계의 절차를 계획하고 있습니다. 우선, 인터뷰와 수업 참관 기록은 본 연구 진행자이신 알버트 교수님의 사무실에 보관될 예정입니다. 문서로 작성된 기록물들은 잠금장치가 되어있는 별도의 캐비닛에 보관될 예정이며, 디지털화된 자료(예: 비디오, 오디오 파일)는 비밀번호가 설정되어 있는 알버트 교수님의 컴퓨터에 보관될 예정입니다. 알버트 교수님과 김리나 선생님이 이 자료에 접근할 수 있는 유일한 연구원이며, 분석과정과 결과물 작성시 선생님의 성함은 가명으로 대체되어 표기될 것입니다. 연구 참여자를 구분짓는 가명에 대한 목록표는 다른 자료들과는 분리되어 별도의 잠금장치가 되어있는 캐비닛에 보관될 예정입니다. 연구원들은 참가자의 신원보장을 위한 최선의 노력을 할 예정이지만, 보스턴 대학의 연구 검토기관에서 연구절차의 타당성과 참가자들의 신원보호를 위해 모든 자료를 검토할 수 있습니다.

자발적 참여와 탈퇴

선생님께서는 자발적으로 본 연구에 참여하셨습니다. 만일 선생님께서 참여하시지 않기로 결정하셨다면, 그러한 결정은 선생님의 경력이나 교사로서 활동하는데 어떠한 지장도 미치지 않을 것입니다. 선생님께서는 또한 언제든지, 어떤 이유로도 이 연구에 참여하시기로 한 결정을 취소하실 수 있습니다. 연구 중간에 참가를 포기하셔도 어떤 불이익도 발생하지 않을 것입니다.

해임

연구원들은 참가자가 연구를 위한 최소한의 노력을 하지 않거나 이 연구에서 요구하는 사항을 준수하지 못하는 것과 같은 참가자 귀책 사유 발생시 참가자를 해임할 수 있습니다.

연락처

참가자는 이 연구에 대한 질문이 있을 경우 알버트 교수님이나 김리나 선생님께 언제든지 연락할 수 있습니다. 알버트 교수님의 전화번호는 01-617-552-4272 이며 이메일은 albertli@bc.edu 입니다. 또한 김리나 선생님의 전화번호는 070-7524-6517 이며 이메일은 rina@bc.edu 입니다. 연구참여자로서의 권리와 신원보장에 대한 의문사항에 대해서는 보스턴 대학의 연구 보호기관으로 문의하실 수 있습니다. 기관의 전화번호는 01-617-552-4778 이며 이메일은 irb@bc.edu 입니다. 선생님께서는 향후 기록을 위해 이 양식의 복사본을 보관하실 수 있습니다.

나는 상기된 내용을 모두 이해하였습니다. 또한, 의문사항에 대해 질문할 수 있는 기회를 가졌고, 질문에 대한 적절한 답변을 얻었습니다. 나는 자발적으로 이 연구에 참여하는 것에 서약합니다. 나는 인터뷰의 녹음과 수업을 촬영하는 것에 동의합니다.

참가자 이름: _____

참가자 서명: _____ Date: _____

나는 이 문서의 복사본을 제공받았습니다.

Appendix C:
Interview Protocols

1. Approaches for the First Interview

This interview consists of three sessions — labeled here as Part 1, Part 2 and Part 3. The 1st part will focus on understanding the participant's background as an elementary teacher. The 2nd part is connected to their teaching mathematics. The 3rd part will be focus on the participant's beliefs about teachers' mathematics knowledge and his/her effort to improve it.

Part 1. Personal Background

A. Personal history

- A1. When did you first start thinking you might want to teach? Why are you interested in teaching?
- A2. Did you like mathematics when you were a student? Why?

B. Teaching experience

- B1. How long have you been teaching elementary students?
- B2. What grades did you teach?
- B3. What grade are you teaching now?
- B4. Have you ever taught this grade before?

Part 2. Teaching Mathematics

C. Preparing mathematics lessons

- C1. When do you usually prepare your mathematics lesson for class (e.g. a day ago)?
- C2. Usually, how long does it take for you to prepare your mathematics lesson?
- C3. Do you usually prepare a written lesson plan?
- C4. What is the most important thing to consider when you prepare a mathematics lesson?
- C5. Do you have a preference for teaching material?
- C6. Do you usually use manipulatives in your class? If so, how often do you use them?
- C7. If you use manipulatives, why do you use them? (This question depend on the answer on C6)

D. In the mathematics class

- D1. What is the most important thing to consider when you teach mathematics?
- D2. What do you usually do when most students do not understand what you are teaching or meet your expectation?
- D3. What do you usually do when most students seem to think what you are teaching is too easy?
- D4. What do you usually do when the gap of understanding seems to be huge among students than what you expected it to be?

E. Assessment

- E1. How do you assess student learning of the mathematics?
- E2. Do you have a preference for assessment methods (e.g. paper-based, performance based)?
- E3. If students do not have high performance on your test, how do you help them improve their learning? If interviewee is not clear about how to answer the question, then give the teacher an example. For example, do you have them take the test again, tutor them, or suggest that they get help outside of school?

E4. Do these things help them perform better in the classroom? Please explain. (Base the answer to question E3).

Part 3. Developing teachers' mathematical knowledge

F. Belief

The first questions focus on the interviewee's general beliefs related to teachers' pedagogical content knowledge in mathematics. The next four are more specific multiple-choice questions based on An, Kulm, and Wu's (2004) study.

- F1. What do you think in the most important mathematical knowledge elementary teachers should have? If the teacher provides several examples, ask the teacher to rank them in order of importance.
- F2. What is the most essential component to build on students' mathematics idea? And why? (If a participant does not know the meaning of the following examples, the interviewer will explain briefly.)
- connect to prior knowledge
 - use concept of definition
 - connect to concrete model
 - use rule and procedure
- F3. What is the most essential component to address students' misconceptions? And why? (If a participant does not know the meaning of the following examples, the interviewer will explain briefly.)
- address students' misconception
 - use questions or tasks to correct misconceptions
 - use rule and procedure
 - draw picture or table
 - connect to concrete model
- F4. What is the most essential component to engage students in mathematics learning? And why? If a participant does not know the meaning of the following examples, the interviewer will explain briefly.)
- manipulative activity
 - connect to concrete model
 - use both representations (are & repeated addition)
 - give examples
 - connection to prior knowledge
- F5. What is the most essential component to promote students' thinking about mathematics? And why? (If a participant does not know the meanings of examples, the interviewer will explain briefly)
- provide activities to focus on students' thinking
 - use questions or tasks to help students' progress in their idea
 - use estimation
 - draw picture or table
 - provide opportunity to think and respond

G. Developing mathematical knowledge

G1. What kinds of professional development experiences have you had that have assisted

you in teaching mathematics better?

Probe: How were these experiences helpful to you? Did the university, your school or the Ministry of Education provide them?

- G2. What was the most efficient way for you to improve your mathematical knowledge (e.g. to participate in teacher education program, to read a book related to teaching methods, etc.)? If you have several examples, please rank them in order of importance.

2. Approaches for the Second and Third Interview

The second interview is going to concentrate on the participant's pedagogical content knowledge in mathematics based on TIMSS, which is a set of questions for evaluating elementary teachers' pedagogical knowledge in mathematics (Ball, 1988). The questions in this section have two basic functions: (1) to sample the prospective teacher's understanding of a range of mathematical concepts and (2) to explore views of mathematics and of teaching and learning mathematics by asking what s/he thinks s/he would do or say in given situations (Ball, 1988, p. 233)

Part 1. Teachers' mathematical knowledge

H. Knowledge of mathematics and ideas about teaching (& learning) Mathematics

H1. Responding to student ideas: Geometry

Something that is often taught in kindergarten and first grade is the names of geometric shapes. Suppose you are teaching first grade and you notice that one of your students has labeled a picture of a square with an R (for rectangle). What would you want to do or say? Explain your statement.



H2. Responding to students' novel ideas: Perimeter/Area, Proof

Imagine that one of your students comes to class very excited. She tells you that she has figured out a theory that you never told the class. She explains that she has discovered that as the perimeter of a closed figure increases (gets longer), the area also increases. She shows you this picture to prove that what she is saying is true:

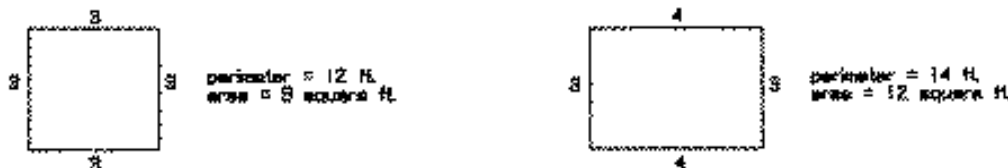

How would you respond to this student?

(Note: Give grade level — 8th-9th grade — only if informant asks.)

Probes:

If the teacher is uncertain about whether this is actually true or not, say,

In teaching, this will happen that something may come up where you aren't sure yourself about whether the mathematics is correct or not. I'm interested in how you think you'd react to that. What would you do or say?

If the teacher comments that this is not a proof or that they would be concerned that the student thinks this is a theory, try to learn why this is not a proof or a theory, and what s/he would do or say in response to the student.

If teacher focuses on praising the student for doing some math outside of class, say:

Is there anything else you'd want to do or say?

If teacher says that how s/he would respond would depend on who the student was, say:

Could you give me a couple of examples? Then ask, Why is that what you would

do with such a student?

If person doesn't mention the rest of the class, say:

Is this something you would bring up with the rest of the class? Why or why not?

H3. Responding to student difficulties: Place value

Suppose you are trying to help some of your students learn to multiply large numbers. You notice that when they try to calculate

$$\begin{array}{r} 123 \\ \times 645 \\ \hline \end{array}$$

The students seemed to be forgetting to "move the numbers" (i.e., the partial products) over on each line. They are doing this instead:

$$\begin{array}{r} 123 \\ \times 645 \\ \hline 615 \\ 492 \\ \underline{738} \\ 1845 \end{array}$$

instead of this:

$$\begin{array}{r} 123 \\ \times 645 \\ \hline 615 \\ 492 \\ \underline{738} \\ 79335 \end{array}$$

What would you do if you noticed that several of your students were doing this?

Probes: If the teacher says, "I'd show them to put zeroes in," ask:

What if some student asks, "How can we just add zeroes like that — it changes the numbers!"

If the teacher says, "I'd tell them to just put X's in to hold the places lined up," ask:

Where did you get that idea?

If teacher mentions "places," probe to find out how he/she talks about place value.

Don't assume that this means that the teacher is referring to the value of the places.

Probe comments about zero being a "placeholder" or "not a number."

H4. Evaluating student responses: Ratio/Proportion, Variables.

Now, suppose your students are learning to use variables to express mathematical relationships. Imagine that you have given them some statements to transform into mathematical statements. Here is one student's work on two of the exercises:

Probes:

a) In a small bag of M&Ms, there are five times as many brown candies as yellow ones. Student answer:

b=the number of brown candies

y=the number of yellow candies

5b=y

b) In the same bag of candy, there are 50% more tan M&Ms than brown ones.

Student answer:

t=the number of tan candies

b=the number of brown candies

$1.5b=t$

Are these expressed the way you'd do them?

Do you think this student is getting the idea? What is it that they are getting (or not getting)?

What would be your next step if this were your student? Many people find this difficult. Why do you think that is?

If the teacher says that either or both of these answers is wrong, ask:

How would you try to help the student understand this?

H5. Responding to student requests for help: Solving equations

Suppose that one of your students asks you for help with the following exercise:

$$\text{If } \frac{x}{0.2} = 5, \text{ then } x =$$

How would you respond?

(Try to pose this in such a way that the teacher doesn't feel that you are assuming that they should tell the student what to do.)

Why is that what you'd do?

H6. Responding to student: Division, Zero

Suppose that a student asks you what 7 divided by 0 is. How would you respond?

Why is that what you'd want to say?

If the teacher asks what age the students is, make a note of this request, and then let him/her select the age. Later ask:

You talked about a _____ grader. Would it make a difference if the student were younger (or older)?

Probe statements about zero (as a "placeholder," as "not a number.") If the teacher says, "I'd say it's undefined," say:

What do you mean by "undefined"?

If the teacher says, "I'd say you can't divide by 0," say:

What if a student asks, "Why can't you divide by zero?"

If the teacher says they would show students how, as you divide by smaller and smaller numbers, the answer gets larger and larger, say:

What would I see or hear you doing?

H7. Generating representations: Division, Fractions

a. Division by fractions is often a little confusing for students. People have different approaches to solving problems involving division with fractions. How would you solve this one:

$$1 \frac{3}{4} \div \frac{1}{2}$$

b. Something that many mathematics teachers try to do is to relate mathematics to other things.

(The teacher may have already talked about this earlier in the interview. If so, refer to that.)

Sometimes they try to come up with real-world situations or story problems to show the application of some particular piece of content. Sometimes this is pretty challenging. What would you say would be a good situation or story for $1\frac{3}{4} \div \frac{1}{2}$?

(Something real for which $1\frac{3}{4} \div \frac{1}{2}$ is the appropriate mathematical formulation?)

After informant has described a situation or story, ask:

How does that fit with $1\frac{3}{4} \div \frac{1}{2}$? Would this be a good way to help students learn about division by fractions?

If the teacher struggles with this, or cannot do it, say:

Many people find this hard. In your view, what makes this difficult?

H8. Organizing curriculum: "The big ideas"

For this question, I'd like you to pick a grade you can imagine teaching. . . . What grade is that? Early in the fall, the principal of your school meets with each teacher to discuss the teacher's goals for their students. What would you say in describing what some of the most important things you'd be trying to accomplish in mathematics across the year with your _____ grade pupils?

Probes:

(The point of this question is to explore the informant's sense of the important ideas in mathematics and the goals of school math instruction.)

What do you mean by that? Why is that important to you?

If the teacher mentions "problem solving" or other fashionable terms, probe for what they mean by such terms: e.g.,

You just used the word _____, which is something many people are talking about these days. What do you mean when you use that term?"

If the teacher says he/she doesn't know enough about the school curriculum for that grade, ask:

Are there any important ideas that come to mind around that grade? Are there any things you'd say regardless of the grade you were teaching?

I. Planning and teaching mathematics: Textbook exercise

For the last question, I'd like to spend a little more time thinking about one particular topic that you may work with when you teach.

Elementary candidates: subtraction with regrouping

This question is intended to do several things: (1) to delve more deeply into the student's understanding of one topic, (2) to explore his/her thinking about how to help others learn it and what that would mean — can he/she see the concept through the eyes of a learner? (3) what tasks would he/she use? what explanations? how would he/she decide if the learners had learned it?

Elementary Task: Subtraction with Regrouping

Now we'll spend a little more time thinking about one particular topic that you may work with when you teach. We'll use this page from a second grade math textbook as the basis for the last part of the interview.

EI1. Do you remember learning this yourself? What do you remember? Listen for what the person considers the "this" here — e.g., subtraction, "borrowing,"

lining up numbers in columns. Don't impose "subtraction with regrouping."
Do you remember this being easy or difficult for you or for any of your classmates?

Do you remember anything your teacher did?

EI2. What do you think about this workbook page? I'm interested in what your impression of it is.

Are there things you think are quite good in here? Some things you think are weaknesses or flaws? Why?

EI3. What would you say a pupil would need to understand or be able to do before they could work on this?

Why is _____ important for this? Is there anything here that you think might be especially hard for pupils?

EI4. Can you describe a little bit about how you would approach this if you were teaching second grade? Don't feel that you have to stick to either of these pages page if you have another way you'd want to work with your class, but you can use it if you choose.

Why would you do that? How did you come up with this idea/approach? What do you mean by _____?

Can you give me an example of what you mean? Is there another way you can imagine doing this?

EI5. How could you tell if your students were "getting it"?

Probe for what it means to "know" or "understand" — or whatever word they use — something in mathematics.

What would you look at or try to pay attention to?

EI6. Now, here's a copy of one student's work on this page. Take sometime to look it over and then let's talk about what you make of Jina's work.

I'm curious about what different people do when they check work like this.

Can you describe what you did as you looked over her paper?

EI7. What do you think is going on here with Susan? What do you think she understands? Why do you think that?

What's your hunch about why she got some of these wrong? Why do you think that?

What do you think Jina doesn't understand? Why do you think that?

EI8. Okay, imagine that Jina is your second grade pupil. How would you respond to this paper?

What would you do next with Jina, or what would you have her do?

EI9. If you were working on this with your class and one pupil said, "Why are we learning this? I already have a calculator and I can do these problems on there," how would you respond?

EI10. Suppose one of your pupils told you that he or she had come up with a new way to do this that didn't require "all that crossing out." The pupil came up and showed you the following: (Explain)

$$\begin{array}{r} 36 \\ - 19 \\ \hline -3 \\ + 20 \\ \hline 17 \end{array}$$

What would you make of this and what do you think you'd say?

ED11. Is there anything you wish you knew more about in order to teach this? How would you go about learning that?

 계산을 하시오.

$$\begin{array}{r} 78 \\ - 29 \\ \hline \end{array}$$

$$\begin{array}{r} 35 \\ - 18 \\ \hline \end{array}$$

$$\begin{array}{r} 42 \\ - 17 \\ \hline \end{array}$$

This textbook section is taken from the Second Grade Korean National Mathematics Textbook, The Korea ministry of education. (2007), p.56

Appendix D:

An Example of South Korean National Teachers' Guidebook for 6th Grade (Adapted
from the Ministry of Education, 2007, P. 187-205)

04

Various 3D Figures

● Why should students learn this unit?

Students could promote their spatial awareness by counting the number of wooden cubes or blocks of various shapes. Also, students could understand the construction of the shape of various buildings and artworks by this method of understanding by visualizing.



- The background of Cover
 - Various shapes made by rectangular parallelepiped container



- The background of Cover
 - Finding out the pattern of laying bricks from castle wall

- Facts of Instruction

In warm-up section of each lesson, it lets us guess the shape of daily goods or buildings as well as wooden cubes when seen from many directions.

Even if it might be the stories that are irrelevant with the details of the lesson, the students are made to realize that the shape of wooden cubes or objects may vary depending on the direction. The unit has to make students raise the sense of identifying the relationship between position and relationship of objects in two dimensional or three dimensional space in their head.

While teaching the details of each lesson, be careful not to implant the method of solving problem mechanically by paying attention to such overall objective.

A Overview of Unit

In this unit, the number is found by looking at the shape of piling up the wooden cubes. It is made up of the activity of guessing and checking the shapes seen from each direction. Not only the wooden cubes, but it lets us understand the change of shapes when various three dimensional figures or buildings and artworks in daily life are seen from many directions. Through such activity, the student is able to solve spatial problems and make decisions in daily life as well as understanding the concept of space.

(1) Objectives

- ① Students can understand the way to present the number of wooden cubes precisely.
- ② Students can count the number of wooden cubes of various shapes.
- ③ Students can find patterns using wooden cubes
- ④ Students can draw a shape of wooden cubes seen from above, front and sides.
- ⑤ Students can draw a shape of three-dimensional figures seen from above, front and sides.
- ⑥ Students can draw a shape of various buildings and artworks seen from above, front and sides

(2) Flow of lessons

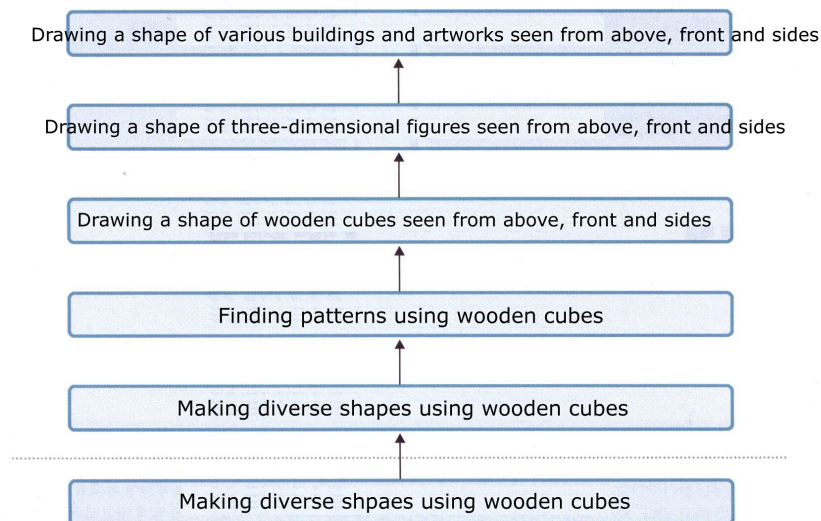

B Step of Lessons

Order Pages	Subjects	Contents	Workbook
<u>1</u> 54~55 쪽	Finding out the way to present the number of wooden cubes precisely	-This lesson has been organized to make various shapes using wooden cubes. - In addition, this is a lesson of finding out the role of sketch to indicate the number of wooden blocks correctly.	62~63 쪽
<u>2</u> 56~57 쪽	Making diverse shapes using wooden cubes	-This lesson has been organized to find the number of wooden cubes piled on each partition by thinking of the sketch as each partition in case the sketch is not complicated.	64~65 쪽
<u>3</u> 58~59 쪽	Finding patterns using wooden cubes	-This lesson has been organized to find pattern using wooden cubes have advantage of being able to find various patterns with one wooden cube shape.	66~67 쪽
<u>4</u> 60~61 쪽	Drawing a shape of wooden cubes seen from above, front and sides	-This lesson has been organized to become familiar with spatial orientation through the activity of guessing, drawing and checking the shape of wooden cubes seen from above, front and sides to intuitively identify the position and relationship on space.	68~69 쪽
<u>5</u> 62~63 쪽	Drawing a shape of three-dimensional figures seen from above, front and sides	-This lesson has been organized to draw and check the shape of three-dimensional figures seen from above, front and sides to intuitively identify the position and relationship on space.	70~71 쪽
<u>6</u> 64~65 쪽	Drawing a shape of various buildings and artworks seen from above, front and sides	-This lesson has been organized to draw and check the shape of buildings and artworks seen from above, front and sides to intuitively identify the position and relationship on space.	72~73 쪽
<u>7</u> 66~67 쪽	Evaluation	-Students are able to solve spatial problems.	
<u>8</u> 68 쪽	Heuristic Activity	-Students were made to naturally find out the fact that wooden cubes may exist even at invisible parts without sketch and that number can be shown in various ways through the inquiry.	
<u>9</u> 익힘책	Problem Solving	-Students are able to make decisions in daily life as well as understanding the concept of space.	74, 76 쪽

■ Background of Mathematic Theory

(1) Spatial Sense

NCTM(1989) has defined spatial sense as one's surrounding condition and intuitive sense toward this surrounding condition. While this spatial sense places emphasis on sensational aspect obtained by informal map on space, Hoffer(1993) has stated that promoting spatial awareness and study of geometric concept complement each other because promoting spatial awareness and forming geometric concept take place at the same time in perceiving the relationship between figures and the characteristics of figure.

(2) Piaget's Spatial Concept Development

Piaget has classified the spatial concept development of students into 3 steps below.

(A) Topological Spatial Concept

The topological spatial concept is the stage of abstracting the property of target object in shape, distance and position perspectives without paying attention to the relationships such as size of object, geometric form and angle, etc.

The topological forms are not fixed and changed into different form by increasing or decreasing the form. Therefore, the closed shapes like rectangles, circles or triangles are all same shapes according to topological concept. The topological spatial concept is the most elementary stage in the development of spatial sense formed between the age of 3~7.

(B) Projective Spatial Concept

The projective spatial concept deals with thinking of an object by the relationship with certain different location of that space without thinking of it by itself.

The projective spatial concept may recognize an object as same after looking at it by changing the direction although the actually seen size and shape get changed.

The projective spatial concept is a developed stage of being able to combine between objects at certain point of view formed between age of 5,6~10.

(C) Euclid Spatial concept

The Euclid spatial concept is the stage where the concept of distance, size, angle and parallelism are formed by positioning as perfect organization called horizontal and vertical without remaining at perceiving objects by projection. Once the students gain Euclid perception, they get to understand that the characteristics of size, shape and angle, etc are maintained without being changed although the position changes while performing movements such as relocating, turning and flipping.

(3) Subcategories of Spatial Sense Ability

(A) Spatial Ability Analysis of Mcgee(1979)

Mcgee(1979) has classified the factors organizing spatial ability mainly into spatial visualization and spatial orientation. The spatial visualization ability stands for the ability to rotate, rearrange or combine an object presented as illustration with an ability to manipulate, rotate or change direction in one's mind. The spatial orientation stands for an ability to understand the arrangement of elements inside the spatial pattern and not get confused even if the direction of presented spatial image gets

(B) Spatial Ability Analysis of Lohman(1979)

Lohman has explained that the spatial ability is consisted of three factors called spatial orientation, spatial perception and spatial relationship by adding spatial relationship to two factors of Mcgee.

- ① Spatial Relationship : While this could be called mental rotation for the most part, This is an ability to rotate one or more visualized object quickly and accurately in one's mind.
- ② Spatial Perception : This is an ability to rearrange the pieces of one object in one's mind in order to perform origami or complete the overall form.
- ③ Spatial Orientation : This is an ability to imagine how a given object or series of objects will be indicated from a spatial view of different from the one where the object is actually seen.

■ Discussions

• Discussion 1

Draw wooden cubes on graph paper while drawing the shape seen from above, front and sides. The role of graph paper is to help students express the wooden cubes of same size. Therefore, while drawing on the graph paper, the ones that express correct number are all treated as correct answers regardless of the location inside the graph paper.

Ex) Draw by thinking of this shape seen from front.

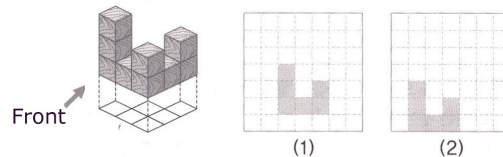

⇒ Because the student just has to indicate the shape of figure seen from the front, it is treated as correct answer regardless of which whether the location is on (1) or (2) on the graph paper.

• Discussion 2

While drawing the shape seen from above, front and sides, it is difficult to for a student to identify the precise length, size and orientation by looking at the illustration expressed on two dimensional plane. Therefore, the ones with correct overall shape are all treated as correct answers.

Ex) Draw by thinking of this shape seen from above.

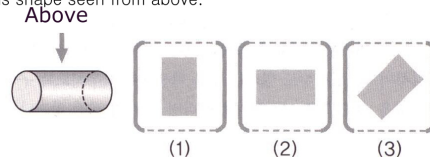

⇒ Because the student just has to indicate the shape of figure seen from the above, it is treated as correct answer regardless of which whether the location is on (1), (2) or (3) on the graph paper.

Lesson 1

I can find the number of wooden cubes by observing (1)

1. Objective

Students can understand the way to present the number of wooden cubes precisely.

2. Instruction

■ Warm-Up

The textbook shows that the main shape made by wooden cubes, which is going to use during the whole lesson.

Students can talk freely about their own experiences using wooden cubes or blocks. In addition, students can guess the number of wooden cubes which were used for making the shape.

쌓기나무로 만든 입체도형을 보고 쌓기나무의 개수를 구할 수 있어요 (1)

보관용기

시연이는 쌓기나무를 이용해 마을을 만들기로 하였습니다. 우선 여러 개의 쌓기나무로 다음과 같이 성을 완성했습니다.
Si-Youn decides to built village with wooden cubes.
First of all, she made a castle.



*How many wooden cubes do you think are necessary to make the same shape as the illustration?
Why do you think so?

- Can there be more low pile of wooden cubes behind the high pile of wooden cubes?
- Can you explain the way to indicate the number of wooden blocks correctly?
Why do you think so?

54

■ Background of Mathematic Theory

When students are asked the number of wooden cubes used after showing the drawn shape of wooden cubes, the students generally make two types of mistake. One is counting the number of partial section and another is counting only the number of wooden cubes of visible area (Jeon, Young Soo, 2007). The activity of this lesson has the purpose of making students understand that wooden cubes may exist even at invisible areas when the wooden cubes of three dimensional space is indicated as 2 dimensional plane and it is difficult to express the wooden cubes that are not seen this way on a plane. The students are guided to have adequate consideration of what problems are caused by this part that cannot be indicated and what methods can be used to solve this problem.

■ Warm-up

The activity of making various shapes using wooden cubes or blocks often encountered in daily life is presented. Consider and discuss the details to be learned through this situation. In the question of 'How many wooden cubes do you think are necessary to make the same shape as the illustration?', the student may answer by counting only the number of wooden cubes of visible area or may not be able to count the number of wooden cubes at all. Here, all thoughts are accepted regardless of whether they're right or wrong. Warming-up is not an introduction activity to instruct the activity of counting the number of wooden cubes correctly, but it is the content organized to make students understand that there can be more wooden blocks hidden behind the drawn shape of wooden cubes when the three dimensional wooden cubes are indicated as two dimension. If the student is having a hard time understanding that there can be more wooden cubes on the back only with illustration of textbook, it is also ideal for the teacher to build up the wooden cube shape similar to the textbook illustration to make them understand the hidden area by showing that there can be more low pile of wooden cubes behind the high pile of wooden cubes.

111 Let's find out the way to indicate the total number of wooden cubes correctly.



How many wooden cubes do you think are necessary to make the same shape as 'A'?

How many wooden cubes do you think are necessary to make the same shape as 'B'?

What is the difference between A and B?

Which is better to indicate total number of wooden cubes?

112 Let's find out another method to indicate the number of wooden cubes correctly.



Do you have another idea to indicate the total number of wooden cubes?

Discuss another method to indicate the number of wooden cubes correctly.

55

■ Activity 1

Students can talk freely about their strategies to find out the number of wooden cubes.

- Students have to find out the role of sketch under the shape made by wooden cubes.

■ Activity 2

Students can discuss another method to indicate the number of wooden cubes correctly.

■ Activity 1

This is an activity of finding out the role of sketch to indicate the number of wooden blocks correctly. Because studying the method of counting the number of wooden cubes precisely is the content of Lesson 2, the students should understand the method for indicating the number correctly and not counting the number of wooden cubes correctly in Activity 1. In Illustration A and B, the students are to realize what the difference between the sketch being drawn and not being drawn. The role of sketch is to let students know the existence of wooden cubes at the invisible area and made to understand that the number of wooden cubes can be indicated correctly through this fact.

■ Activity 2

This is another activity of discussing another method to indicate the number of wooden cubes correctly.

The sketch drawn in the textbook is not the mathematically defined sign, but used as one of various methods to indicate the number of shapes built with wooden cubes precisely. Therefore, the method of drawing the sketch precisely must not be explained to the students or evaluated. The sketch is merely a supplementary device for drawing the shape of wooden cubes.

Activity 2 is the one organized to raise the mathematical communication ability by making students discuss other mathematical methods to indicate the three dimensional figures correctly on two dimensional plane in addition to the sketch introduced in the textbook as well as for the students to clearly understand that there can be more wooden cubes hidden behind the illustration of drawing the wooden cubes during the discussion process. The student may answer that 'the wooden cubes can be indicated as sketch just like the sketch of a rectangular parallelepipedon' or 'indicates all illustrations seen from each direction'. The student may also answer that 'a mirror can be placed on the back or draw the illustration like the sketch at the back of wooden cube shape'.

Lesson 2

I can find the number of wooden cubes by observing (2)

1. Objective

Students can count the number of wooden cubes of various shapes.

2. Instruction

■ Activity 1

[Activity 1] is the activity of finding the number of wooden cubes by using a sketch under the shape made by wooden cubes.

■ Practice

Finding the number of wooden cubes piled on each partition by thinking of the sketch as each partition in case the sketch is not complicated

쌓기나무로 만든 입체도형을 보고 쌓기나무의 개수를 구할 수 있어요 (2)

Let's find out the total number of wooden cubes.

- What is the number of wooden cubes to be piled in No. 1 position?
- What is the number of wooden cubes to be piled in No. 2 position?
- What is the number of wooden cubes to be piled in No. 3 position?
- What is the number of wooden cubes to be piled in No. 4 position?
- What is the total number of wooden cubes?
- Is there another way to find out the total number of wooden cubes?

Find out the number of wooden cubes in order to make each shape below.

56

■ Activity 1

Through the activity of Lesson 1, the necessity of wooden block shaped sketch in order to indicate the number of wooden cubes correctly has been comprehended. [Activity 1] is the activity of finding the number of wooden cubes piled on each partition by thinking of the sketch as each partition in case the sketch is not complicated. In order to pile up the wooden cubes high by thinking of the wooden cube shape in vertical partition, the fact that wooden cubes as many as the number of layers are needed can be thought of even if the wooden cubes piled up below are invisible.

■ In the question 'what is the number of wooden cubes to be piled in No. 1 position?', the students may say the correct answer by saying '2' or may not be able to find the number of wooden cubes used. The important thing in this activity is raising the beginning ability to guess the number of invisible wooden cubes rather than the right answer. Therefore, the students should be helped to infer the number of wooden cubes in No. 1 position naturally by counting the number of wooden cubes in No. 2, 3 and 4 positions.

■ Correct Answer

The number of wooden cubes piled in No. 3 position is 1 and 1 layer can be created with 1 wooden cube. The number of wooden cubes piled in No. 2 position is 2 and consisted of 1 layers. The number of wooden cubes piled in No. 4 position is 3 and consisted of 3 layers.

Through such process, the students should be made to think logically that although the part shown in the illustration of textbook is only one side of wooden cubes for the number of wooden cubes in No. 1 position, the wooden cubes in No. 1 position is also 2 layer so that 2 wooden cubes have been used because the height is same as the 2 layered wooden cubes piled up in No. 4 position. The students should be guided to say the reason why the answer must be 2 rather than saying the correct answer called '2'.

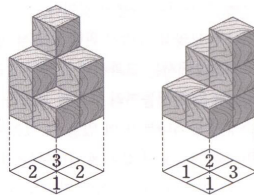

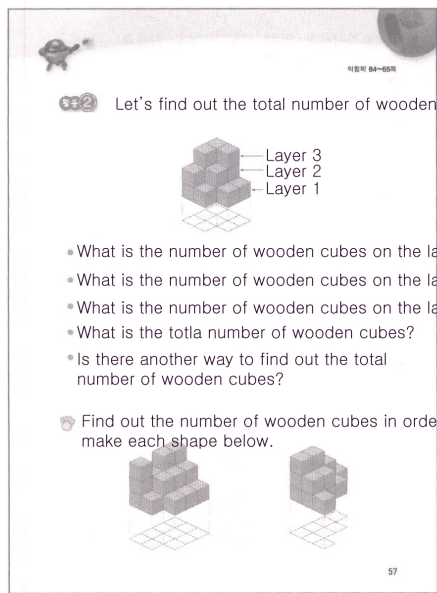

■ Activity 2
 [Activity 2] is the activity of finding the number of wooden cubes in case the sketch is complicated.
 - Students can find the total number of wooden cubes can be found by adding after finding the number of each layer by thinking of the overall shape of wooden cubes as each layer.

■ Practice
 Finding the total number of wooden cubes by adding after finding the number of each layer by thinking of the overall shape of wooden blocks as each layer

■ Activity 2

In case the sketch is complicated, it can be more difficult to find the total number of wooden cubes by adding up after finding the number by dividing the sketch into each partition. In this case, the total number of wooden cubes can be found by adding after finding the number of each layer by thinking of the overall shape of wooden blocks as each layer. In this case, the number is counted from layer 3 where the number can be verified just with illustration. In order to place a wooden cube on layer 3, the students should be made to understand that wooden blocks of layer 1 and 2 are needed even if the piled shape is invisible. Then the students are guided to find the number of each layer more accurately after being aware that there can be wooden blocks even in parts hidden by upper layer by finding the number of wooden cubes of layer 2 and 1. At this time, the students are encouraged to freely present the method to find easily on their own such as 'add by finding only the number other than the position where layer 3 is placed on the number of cubes on layer 3' and the method of cramming the mechanical method should be avoided. [Note] Method 1 and Method 2 are only the strategies to find the number of wooden cubes. The students should be guided not to memorize the method but to select the comfortable strategy while finding the number of wooden cubes on their own after gaining understanding.

■ Correct Answer

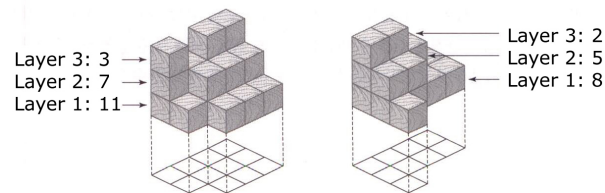

Lesson 3

I can make diverse shapes with wooden cubes and find the total number of cubes(1)

1. Objective

Students can count the number of wooden cubes of various shapes.

2. Instruction

■ Activity 1

[Activity 2] is the activity of finding pattern using wooden cubes.

■ Practice

Finding the pattern by making directly by looking at the illustration presented in the textbook.

쌓기나무로 여러 가지 모양을 만들고 규칙을 찾을 수 있어요

Let's place wooden cubes in pattern.



- How many wooden cubes were used on 1st layer?
- How many wooden cubes were used on 2nd layer?
- Can you tell the pattern of number of wooden cubes?
- Can you tell the pattern of position of wooden cubes?
- State what pattern was used to pile wooden cubes.

Find pattern using wooden cubes.



58

■ Activity 1

The activity of finding pattern using wooden cubes have advantage of being able to find various patterns with one wooden cube shape. First, the pattern of number can be found by indicating the number of wooden cubes changed according to each layer or the pattern of spatial arrangement also can be found according to the shape and position of piling the wooden cubes. In Activity 1, try placing wooden cubes in pattern by setting up two dimensional space consisted of only x-axis and y-axis to discover various patterns within.

- Making students say various patterns at once after looking at one wooden cube pattern would be the most difficult task for them. Therefore, check the pattern of number by indicating the number of wooden cubes as number and find the pattern of position by looking at the change of wooden block shape piled up vertically.
- In the activity of finding out the pattern of number of wooden cubes, students can say 'one wooden cube being added and one cube being subtracted gets repeated' or '5 wooden cubes are placed on odd number layer and 6 wooden cubes are placed on even number layer'. The students are guided to find the pattern of number placed on each layer from various points of view.
- In the activity of finding out the position of wooden cubes, the students are made to find pattern from various points of view such as 'place wooden cubes in a cross arrangement' or 'place wooden cubes so that two wooden cubes are laying on one wooden cube'.
- In the last question of 'state what pattern was used to pile wooden cubes', the students are to say the pattern of number and position at the same time. Through such question, the students realize that 2 or more patterns can be found in one wooden cube shape. At this time, it wouldn't be necessary to say two sentences by connecting them as one sentence. Even in the evaluation on this, if the perspective of student is verified as being able to find other two types of patterns at the same time, it should be treated as correct answer.

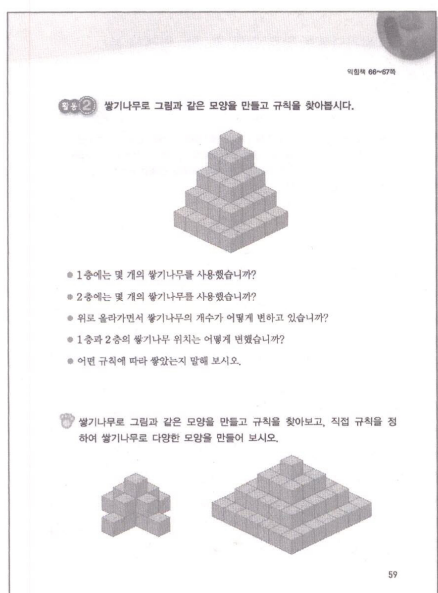

■ Activity2

[Activity 2] is the activity of finding the pattern by setting up a three dimensional space consisted of x-axis, y-axis and z-axis

■ Practice

Finding the pattern by making same the shape presented on textbook.

■ Activity2

In Activity 2, try placing wooden cubes in patterns by setting up a three dimensional space consisted of x-axis, y-axis and z-axis to discover various patterns in them.

- In the activity of finding the pattern of number of wooden cubes, the student counts the number of wooden cubes on each layer first and thinks about which pattern will be used to explain that number. The important thing while explaining the pattern of number of wooden cubes, the orientation must be indicated at the same time. That is because it can become arithmetic sequence or geometric sequence depending on which orientation among up, down, left and right is used for explanation. Although the question was limited to 'the instance of going up' in the textbook, the students are guided to explain the pattern with various methods according to orientation by setting up various orientations during the actual instruction.
- In the question of 'how is the number of wooden blocks changed as they go up?', the students are guided to present the patterns they have found in various ways such as 'the number of wooden cubes is decreasing as they go up. The number as many as multiplying the same number twice is placed on each layer such as 25 on layer 1 and 16 on layer 2.' or 'the number of wooden cubes decreases in the order of odd number less than 9 starting with 9 as they get piled up such as 9, 7 and 5'. At this time, if the student is having difficulty explaining precisely with complete sentences, the students are made to express their thoughts by giving examples or dividing into many sentences and the teacher should help students understand the method of explaining patterns by correcting them into proper sentences after listening to everything that the student says.
- In the question of 'how did the position of wooden blocks on layer 1 and layer 2 change?', the teacher first guides students to present the thoughts freely and instructs them to find out that the position where wooden cubes are placed does not change in layer 1 and layer 2 but getting decreased by 1 in the direction of two set corners.

Lesson 4

I can draw a shape of wooden cubes seen from above, front and sides.

1. Objective

Students can draw a shape of wooden cubes seen from above, front and sides.

2. Instruction

■ Warm-up

Have the students talk about the experience of making something like a space-ship using wooden cubes or blocks in daily life. During the discussion, students can realize that although objects are made to look like a certain concrete object while making various shapes, they can be seen as completely different shapes depending on the direction where you see them.

쌓기나무로 만든 것의 위, 앞, 옆에서 본 모양을 알 수 있어요

생각하기

미술 시간에 쌓기나무를 이용해 다양한 물건의 모양을 만들거로 하였습니 다. 재현하는 쌓기나무로 우주선을 만들었습니다. "우와! 멋있다!" 친구들이 감탄하기 시작했습니다. 친구들은 재현이 어떻게 만들었는지 우주선을 공 꾀히 살펴보았습니다.

Jae-Yon made a spaceship with wooden-cubes.



- How would the shape of spaceship look like seen from above?
- How would the shape of spaceship look like seen from front?
- How would the shape of spaceship look like seen from sides?
- Why do you think so?

40

■ Background of Mathematic Theory

The spatial orientation is an ability to imagine how a given object or series of objects will be indicated from a spatial view of different from the one where the object is actually seen (Lohman, 1979). This lesson has been organized to become familiar with spatial orientation through the activity of guessing, drawing and checking the shape of wooden cubes seen from above, front and sides to intuitively identify the position and relationship on space.

■ Warm-up

Have the students talk about the experience of making various shapes using wooden cubes or blocks in daily life. During the discussion, the teacher makes students realize that although objects are made to look like a certain concrete object while making various shapes, they can be seen as completely different shapes depending on the direction where you see them.

- In the question of 'how would the shape of spaceship piled up with wooden cubes shown as textbook illustration look like seen from above, front and sides?', students may answer the shape seen from each direction correctly or may speak of completely different shape. Here, all thoughts are accepted whether they might be right or wrong.
- In 'explain why you think so.', the students answer with a reason they thought of. Even if students give answers that are not mathematically appropriate, all answers are accepted and approved.
- In the question of 'explain why you think so.', the teacher may show photographs taken from each direction by making the shape of spaceship directly or check the shapes seen from various directions by students themselves making the shape.
- The Warm-up activity is an activity of understanding that the shape of piled wooden cubes may vary according to the direction from where they are seen to guess the shape that would be seen while the activity can be substituted as an activity of a student piling up the shape directly and another student guessing the shape.

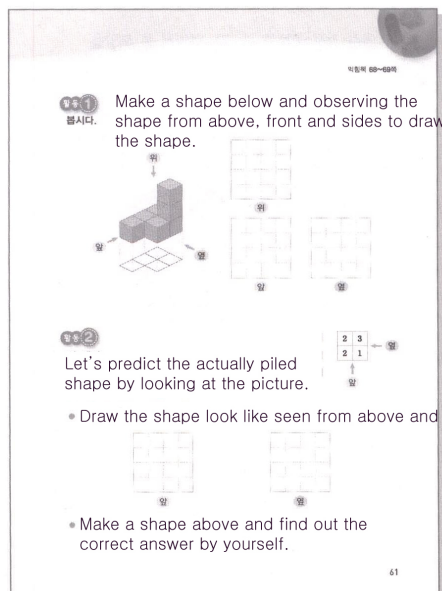

■ Activity 1

[Activity 1] is the activity of making directly by looking at the illustration presented in the textbook, observing the shape from above, front and sides to draw the shape.

■ Activity 2

[Activity 2] is the activity of predicting the actually piled shape by only looking at the picture seen from the above, drawing by thinking of this shape seen from front and sides to check the answer by making with actual wooden cubes.

■ Activity 1

This is an activity of making directly by looking at the illustration presented in the textbook, observing the shape from above, front and sides to draw the shape. At this time, the teacher must inform the direction to be observed from clearly and the have students observe from the position

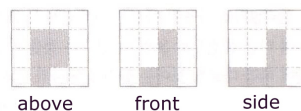

where the shape of wooden cubes are seen as plane by adjusting the level of vision as the same height as the wooden cubes. Various shapes should be presented in addition to the illustration presented in the textbook and have the students practice adequately to identify the change of space and position relationship by intuition through the activity of observing and drawing the shapes.

■ Activity 2

This is an activity of predicting the actually piled shape by only looking at the picture seen from the above, drawing by thinking of this shape seen from front and sides to check the answer by making with actual wooden cubes.

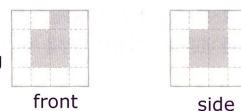

In this activity, students may experience difficulty as they have to predict the piled shape and predict this shape seen from many directions once again. Therefore, the students should be able to reach the study objective by instructing them step by step. First of all, make students understand what each number stands for in the picture of looking down from above and make them have enough practice on predicting three dimensional figures just by looking at the picture of looking down from above by presenting various numbers other than the number presented in the textbook. Although the activity of drawing by predicting the shape seen from above, front and sides has been instructed in Activity 1, because it is more difficult to predict the shape drawn in one's mind than predicting the shape seen from above, front and sides after looking at the illustration the students should have enough practice on this. Finally, have the students realize their own mistake and form spatial sense at the same time through the activity of making wooden cubes directly and comparing them. 4. 여러 가지 입체도형 199

Lesson 5

I can draw a shape of three-dimensional figures seen from above, front and sides.

1. Objective

Students can draw a shape of three-dimensional figures seen from above, front and sides.

2. Instruction

■ Warm-Up

Have the students understand that it may seem as a completely different object although it is easily seen in daily life.

여러 가지 물체를 위, 앞, 옆에서 본 모양을 나타낼 수 있어요

생각하기

비라보는 방향에 따라 물건은 우리가 평소 알고 있는 모습과 다르게 보이기도 합니다. 다음은 어떤 물건을 위해서 찍은 사진입니다. 사진을 살펴보고 어떤 물건인지 알아봅시다.

Sometimes, it may seem as a completely different object although it is easily seen in our daily lives.

• What shape would the object have seen from the front?

• What shape would the object have seen from the side?

• What do you think this object is?

Why do you think so?

62

■ Warm-up

The photograph used in warm-up is a rectangular parallelepiped sesame oil container. Have the students understand that it may seem as a completely different object although it is easily seen in daily life. In addition to the textbook illustration, the Warm-up activity can be substitute with a photograph of an object seen from one direction after the teacher takes a photograph of an object that looks different according to direction among the objects in daily life.

- In the question of 'what shape would the object have seen from the front?' and 'what shape would the object have seen from the side?', students may answer that it would be a square by looking at only the appearance seen from the above. Or they may answer that although the upper part is a rectangular parallelepipedon, it would become narrower toward the bottom because the most wide part is seen from the above. The teacher should encourage students to think creatively by accepting and approving all answers.
- In the question of 'what do you think this object is?', have the students answer what object it is based on the shape seen from the front and sides on their own. While saying the name of object, have the students present the reason for thinking so based on the process of their conjecture. At this time, the teacher does not have to tell the students the name of object. Talk about the shapes of various objects to avoid limiting the thought and help students experience the fact that various shapes can be predicted by looking at just one side.

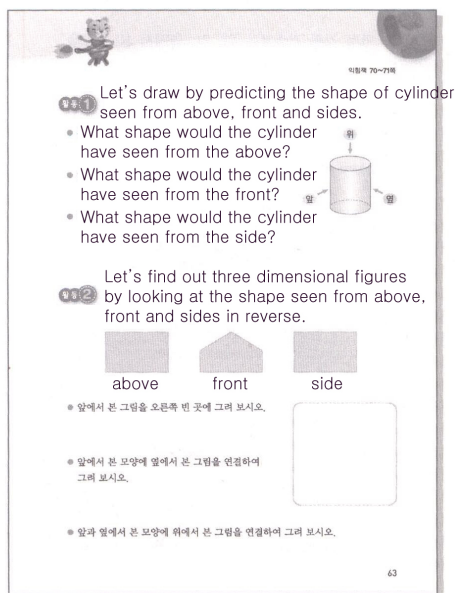

■ Activity 1

[Activity 1] is the activity of drawing by predicting the shape of cylinder seen from above, front and sides.

■ Activity 2

[Activity 2] is the activity of predicting the shape of actual three dimensional figures by looking at the shape seen from above, front and sides in reverse.

■ Activity 1

In Activity 1, perform activity of drawing by predicting the shape of cylinder seen from above, front and sides. At this time, perform activity of predicting the shape seen from above, front and sides by presenting various three dimensional figures such as cone or prism. Although checking the prediction of students with actual three dimensional figure would be the best way, if the teaching instrument is not prepared in school, check the shape seen from above, front and sides with concrete objects similar to the three dimensional figures dealt with in the class such as canned beverage or rectangular paralleloiped pencil case.

[Correct Answer] Circle, Rectangle, Rectangle

■ Activity 2

After the adequate practice of predicting the shape seen from above, front and sides has been performed by looking at the three dimensional figure in Activity 1, perform the activity of predicting the shape of actual three dimensional figures by looking at the shape seen from above, front and sides in reverse. First, have the students freely present on what shape it might be and check by drawing pictures directly. The method of drawing picture should be drawing the picture seen from the front first, then drawing the picture seen from the sides and drawing the picture seen from the above. For the students having difficulty understanding this process, give them opportunity to make the object directly using things such as rubber clay. Also, raise the spatial sense ability of students by making them have enough practice on similar activities in addition to the activities in the textbook.

[Correct Answer]

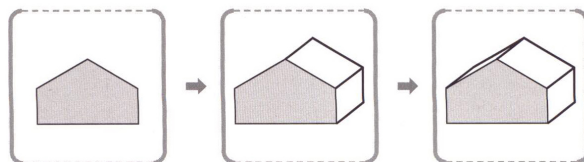

Lesson 6

I can draw a shape of various buildings and artworks seen from above, front and sides.

1. Objective

Students can draw a shape of various buildings and artworks seen from above, front and sides.

2. Instruction

■ Warm-Up

Predict the shape of buildings and artworks in daily life seen from many directions.

여러 가지 건축물을 위, 앞, 옆에서 본 모양을 나타낼 수 있어요

생각하기

하늘 위에서 내려다본 세상은 우리가 평소시에 보던 모습과 다른 모습으로 보입니다. 다음은 헬리콥터를 타고 어떤 건축물을 위에서 찍은 사진입니다. 이 건축물의 전체 모습은 어떤 모양인지 알아봅시다.

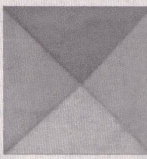

• What do you think the shape of building would be seen from the above?

• What do you think the shape of building would be seen from the side?

• Can you find out the shape of a building?

Why do you think so?

64

■ Warm-Up

Predict the shape of buildings and artworks in daily life seen from many directions through the practice of predicting and visually expressing the space through three dimensional figure.

- In the question of 'what do you think the shape of building would be seen from the above?' and 'what do you think the shape of building would be seen from the sides?', the students may answer that it would be a square by looking at only the appearance seen from the above. Or they may answer that although the upper part is a rectangular parallelepipedon, it would become narrower toward the bottom because the most wide part is seen from the above. The different thing from the activity of previous lesson is that a student may speak of impossible building shape because it is a building actually made in daily life and not a three dimensional figure. The teacher should encourage students to think and answer in a creative way, but guide them to tell their thoughts logically by deciding whether it is a shape that is realistically possible.

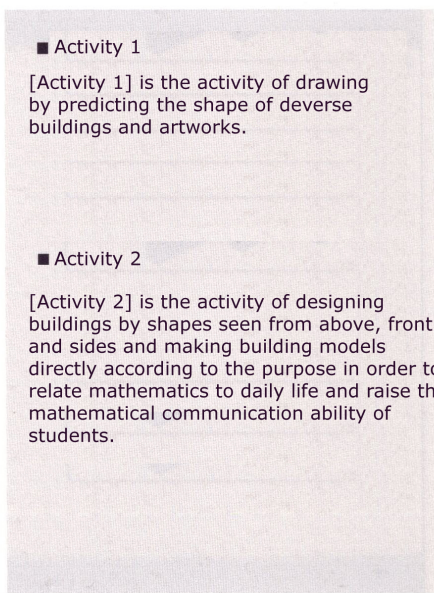
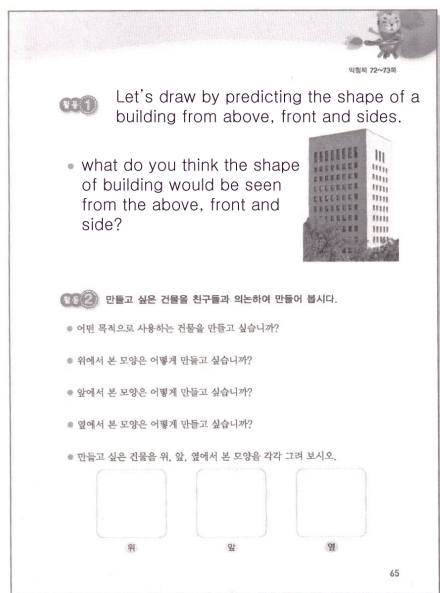

■ Activity 1

Perform the activity of drawing by predicting the shape of pyramid shaped building from above, front and sides. At this time, various geometric buildings and artworks found in daily life can be provided as reference material in addition to the pyramid. Although the best way is to check the prediction of students by looking at the actual building, check with the three dimensional teaching instrument similar to the shape of the building because it is realistically impossible.

[Note] In case the teacher is trying to substitute through provoking and Activity 1 with another photograph or illustration, avoid selecting buildings or artworks that are too complicated reflecting from the standard of students. Use the shape of buildings that have similar form as the ones learned in sixth grade of elementary school. Also, how the overall shape of building should be instructed and must not instruct on the details such as shape of window or shape of bricks, or have the students draw them.

[Note] Treat as correct answer even if the student answers the overall shape without being able to explain the shape seen from above, front and sides.

■ Activity 2

Students have learned the method of understanding by visualizing space in wooden cubes and three dimensional figure while performing the activity of predicting the shape of various buildings and artworks in daily life seen from various directions through Activity 1. In Activity 2, the activity of designing buildings by shapes seen from above, front and sides and making building models directly according to the purpose in order to relate mathematics to daily life and raise the mathematical communication ability of students. At this time, students may design the shapes of incomplete buildings even after making shapes seen from above, front and sides at first. At this time, the teacher should instruct students to record on what was wrong and design to discuss again on how to fix the problem.

탐구 활동 Heuristic Activity

다음 그림처럼 쌓기나무를 쌓았습니다. 앞쪽의 쌓기나무에 가려 뒤쪽의 쌓기나무가 보이지 않습니다. 보이지 않는 쌓기나무가 가장 많을 때 모두 몇 개일지 예상해 보고, 예상을 확인해 봅시다.

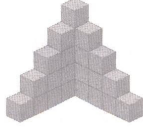

● 보이지 않는 쌓기나무는 몇 개일 것이라고 생각합니까?

왜 그렇게 생각합니까?

● 생각을 확인해 보세요.

68

Reason for Organization of This Page

In this unit, the activity of finding piled patterns and quantity by looking at the shape of piled wooden cubes has been performed. The inquiry has been organized by focusing on students realizing the mistake often seen while counting the number of wooden cubes on their own. In other words, the students were made to naturally find out the fact that wooden cubes may exist even at invisible parts without sketch and that number can be shown in various ways through the inquiry.

Facts of Instruction

Facts of Instruction

Have the students saying 'why do you think so?' present the proof of guessing the number of wooden cubes in the invisible area that they thought of. Looking from the textbook illustration, the student may answer 'there are no wooden cubes right behind the wooden cube seen at the outermost area because it is looking down from the above' or 'the ones seen in between also have to be omitted because the wooden cubes are piled like stairs'. The teacher should accept and approve various thoughts of the students, but guide them to answer by thinking about the condition of problem called 'when there is most number of invisible wooden cubes'.

In 'check your thoughts', the students may perform activity of piling up the wooden cubes shown in the textbook illustration directly and hiding the wooden cubes to become invisible behind them. In this activity, the important thing is not the correct answer for 'how many can be hidden?', but thinking of the method to hide more wooden cubes as students think creatively on their own. Although the activity can be on individual basis, it is better to perform inquiry by sharing various thoughts among students through partner or group activities. It is also a good idea to check each of the shapes made by the students including the photographs taken from the direction seen from the textbook and the ones taken from the back with a digital camera by connecting to a projection TV.