

**CBA · NAU**

College of Business  
Administration  
Northern Arizona  
University  
Box 15066  
Flagstaff AZ 86011

# **Alternative Forms of Program Documentation for the Support of Audit Review: An Experimental Investigation of Usability**

**Working Paper Series 02-06— April 2002**

**T. S. Amer, Ph.D.**  
Associate Professor  
520-523-7370 Office  
520-523-7331 FAX  
tsamer@nau.edu

**Richard F. Lucy, Ph.D.**  
Assistant Professor

**Jo-Mae Maris, DBA**  
Associate Professor

**College of Business Administration  
Northern Arizona University  
Box 15066, Flagstaff, Arizona 86011**

**CBA · NAU**

College of Business  
Administration  
Northern Arizona  
University  
Box 15066  
Flagstaff AZ 86011

# **Alternative Forms of Program Documentation for the Support of Audit Review: An Experimental Investigation of Usability**

T.S. Amer, Ph.D., Richard F. Lucy, Ph.D., and Jo-Mae Maris, DBA

## **I. INTRODUCTION**

Auditors may review information systems and application documentation for a variety of reasons (Wilkinson et al., 2000; Weber, 1999). Internal and external auditors may review documentation for evidence of errors or irregularities. For example, internal auditors may review internally developed application documentation for syntax errors, logic errors, and fraudulent code. External auditors sometimes carry out the same type of review of client documentation. The discovery of errors in either case may lead the auditor to question the existence and adequacy of internal controls. Auditors may also review documentation to determine if unauthorized changes were made to applications. Such changes could result in inefficient, ineffective, or fraudulent information processing. Finally, internal or external auditors may review documentation to determine if various controls exist. For example, an internal auditor may review the work of internal programmers to verify that the threshold criterion for applying a sales discount (e.g., all sales that exceed \$1,000 should receive a discount) is in place. Ineffective documentation would render all these tasks more difficult for both the internal and external auditor, and hence increase both the time and cost of maintaining and monitoring the organization's system of internal controls.

Programmers also review application documentation for a number of purposes (Brooks, 1995). Documentation is critical to support the debugging and maintenance of an application. Programmers require a clear understanding of the internal structure of the application to effectively and efficiently carry out such tasks. For example, a programmer may need to update a conditional application procedure that tests the amount of a customer's purchase to determine if a sales discount should be applied. The programmer would need to review the application documentation to locate and assess the current status of this control. Authorized application changes could then be made to the code directly and update the documentation. Ineffective or unmaintained documentation could hinder the ability of the programmer to locate the point of the modification, especially in cases where the programmer is not currently "intimate" with the application.

Information systems documentation may include application flowcharts, systems flowcharts, logic diagrams, application code, and information pertaining to the operations and testing of the system. With respect to application documentation, the **same** coded application procedure can be represented in the application documentation in **different** ways. For example, a conditional application procedure that tests the amount of a customer's purchase to determine if a sales discount should be applied can be represented in the application documentation in different forms: by a decision tree, by a decision table, by a flowchart, or in structured English. Prior theoretical and empirical research suggests that the form of the documentation may affect the ability of auditors and programmers to efficiently and effectively review the documentation (Hutchins et al., 1985; Amer, 1993).

The objective of this study is to investigate the effect of alternate forms of documentation on the efficiency and effectiveness of the auditor and programmer's review of documentation. The review task of interest involves the auditor or programmer's identification and evaluation of control procedures within an application. For example, an internal or external auditor may review the systems documentation of a customer-billing application to identify and evaluate if the threshold for applying volume discounts is correctly specified in the documentation. If the threshold were incorrectly specified in the documentation, then the billing application would be suspect. This, in turn, would signify that there might be a significant internal control weakness that would lead the auditor to conduct additional compliance and/or transaction testing. The form of application documentation that best supports the identification and evaluation of system controls can increase the effectiveness and efficiency of the audit carried out by an auditor or application maintenance carried out by a programmer.

## II. PRIOR RESEARCH

A few areas of prior research relate to the current research question. First, there is prior research as to the effectiveness of traditional forms of documentation for documenting applications and databases. Another area of prior research is that focused on the effects of alternative forms of information representation on decision-making. This second area of research is commonly referred to as studies of “tables versus graphs.” This area of research is relevant to the current research question because alternative forms of application documentation include both graphical forms (e.g., flowcharts and data flow diagrams) and tabular-like forms (e.g., structured English). Insights gained from this literature on the effects of tables versus graphs on decision-making will shed light on the applicability of theoretical models and other methodological issues to the current study.

### Traditional Forms of Documentation

Curtis et al. (1989) comprehensively tested hypotheses based upon the nature of the tasks for which documentation is used. The authors report the results of several tests conducted on a combination of factors, including decision-making tasks (comprehension, coding, debugging, and modification), documentation type (symbolology and spatial arrangement), and decision-making performance. Curtis et al. (1989) first report a large amount of performance variance is driven by individual differences. Second, response time is an important dependent variable as programmers are focused on achieving a high level of accuracy in their work. Hence “ceiling effects” result when measuring accuracy. Third, in general, documentation using a natural language representation was the least effective and least preferred across a number of tasks.

Similarly, Galletta et al. (1996/1997) examined decision-making performance in the context of debugging of spreadsheet errors. In this case, debugging is similar to the audit review task examined in this study. Among their hypotheses was the notion that reviewing documentation containing formulas results in higher error-detection rate than reviewing documentation without formulas. Thus, the two forms of documentation included documentation with formulas and documentation without formulas. Performance was measured in terms of both the quantity of errors and the time required to find the errors. Their results indicate that spreadsheet reviewers are not aided in their search for errors by having the formulas available.

Shaft and Vessey (1998) examine the role of application domain knowledge and program domain knowledge for the comprehension of computer programs. The authors contend that understanding computer programs is crucial to the performance of many programming tasks; it plays a major role, for example, in the testing and debugging phases of program development and in the later program maintenance and enhancement phases. They did not, however, examine how alternative forms of documentation affect these processes.

### Database Representations

Research examining the effects of alternative representations of conceptual database models on decision-making is also relevant to the context of this study. Similar to application documentation, the same database semantics may be represented in different ways. Most commonly, a conceptual database model may be represented using tabular (relational) or graphical (entity-relationship) form. Prior work in this domain has examined the hypothesis that the entity-relationship representation will better support decision-making and comprehension of the database due to its richer semantic representation of the real-world objects and the attributes of those objects.

Juhn and Naumann (1985) and Batra et al. (1990) examined this hypothesis in the context of database design. In both these studies, subjects were required to use the modeling representations to construct conceptual models of application domains (i.e., a design-oriented task). The results, while somewhat mixed, marginally support the hypothesis that the E-R representation is superior to the relational representation for this type of design task.

Amer (1993) examined the hypothesis in the context of control review. Subjects carried out an audit review of the conceptual data models of five common accounting transaction-processing cycles. The subjects were required to identify errors that were deliberately seeded in the models. Subjects who used the entity-relationship modeling representation made fewer mistakes in identifying errors than subjects who used the relational modeling representation. Amer’s results suggest that using the entity-relationship conceptual modeling representation for database documentation will result in more effective audits of accounting databases.

A study by Chan et al. (1993) compared an entity-relationship representation to a table representation in a querying task and found that a semantic representation resulted in higher performance than a tabular representation. Similarly, Leithaiser and March (1996) explored the influence of database structure representation on the ability of users to learn and use a database system. Four alternative representations of the same databases are developed and compared, each differing in semantics, symbols and means of representing relationships. Two types of semantics are compared: table and entity. They found that differences in representation semantics have a significant influence on

representation learning and use. It took the subjects using the entity representation significantly less time to learn how to read database representations than it took the subjects who used the table representation. Similarly they observed that graphical representations significantly improved learning times over tabular representations, as well as rejecting the hypothesis that the type of symbols used in various graphical representations had an effect on learning.

Taken together, the research cited above suggests that graphical representations (entity-relationship model) are superior to tabular representations (relational model) for decision-making tasks involving database design, comprehension, and review. These results point to the importance of how alternative forms of documentation representation may affect the review of that documentation.

### **Representations and Their Effect on Decision-Making**

Another area of prior research relevant to the current study involves research commonly referred to as “tables versus graphs.” A number of projects are reported in the literature with varying results (see Jarvenpaa and Dickson (1988), Amer (1991), Vessey (1991), and Frownfelter-Lohrke (1998) for summaries and reviews of this literature). Some research in this area has found that graphical representations improve decision-making performance; other research has found that tabular representations improve decision-making performance; still other research has found no difference in decision-making performance across graphical or tabular representations.

An outcome of this body of research was the development of a theoretic model, based on information processing theory, to explain under what circumstances one representation outperforms the other (Vessey, 1991, 1994). Vessey’s theory of cognitive fit views problem solving as an outcome of the relationship between the problem representation and the problem-solving task. It articulates that decision-making performance on a task will be enhanced when there is a cognitive fit (i.e., match) between the information emphasized in the representation type and that required by the task type.

This area of research, and the theory of cognitive fit, are relevant to the current issue because alternative forms of application documentation include both graphical forms (e.g., flowcharts and data flow diagrams) and tabular-like forms (e.g., structured English). The theory of cognitive fit perhaps provides the most appropriate and most elegant theoretical model upon which to base the current research question. Indeed, this model has been applied to the literature that has investigated the effects of tables versus graphs upon decision-making performance, and in other information presentation contexts (Vessey 1991, 1994; Agarwal and Sinha 1996; Tuttle and Kershaw 1998).

### **III. THEORETICAL DEVELOPMENT AND HYPOTHESES**

Vessey (1991, 1994) developed the theory of cognitive fit to explain the relationships between display format and decision making performance. In the case of decision making tasks involving information acquisition and evaluation, the theory proposes that decision performance is enhanced when the problem representation and the task stress the same type of information needed for the decision (Vessey and Galletta, 1991; Vessey, 1994).<sup>1</sup> Decision performance is enhanced because the mental representation formulated is consistent with the problem representation and task. Performance declines when the problem representation and task do not match because the decision maker must compensate by utilizing sub-optimal problem solving processes or by using more time to convert the problem mentally which allows them to then maintain a needed level of accuracy.

In applying the theory of cognitive fit to information display, Vessey (1991, 1994) classified tasks as spatial and symbolic and information representations as spatial and symbolic. Spatial tasks require making associations or perceiving relationships in the data and are best supported by spatial representations (e.g., graphs). Symbolic tasks require extracting discrete data values and are best supported by symbolic representations (e.g., tables). Therefore, increasing the cognitive fit between the representation and the task, for example using graphs to support spatial decisions, increases the efficiency and effectiveness of decision-making.

#### **Applying Cognitive Fit to the Control Review of Application Documentation**

When identifying and evaluating the control procedures within an application the auditor or programmer examines the application documentation to determine the location of the control procedure and then evaluate if it is correctly represented in the documentation. This “review task” may require the auditor or programmer to identify and evaluate different types of control procedures. For example, the auditor or programmer may seek to determine if a

---

<sup>1</sup> The theory of cognitive fit is a special case of cost-benefit theory applied to decision-making that primarily involves information acquisition and well-defined evaluation (Vessey, 1994). The documentation review task used in the current study is just such a task.

conditional application procedure which tests the amount of a customer's purchase to determine if a sales discount should be applied is correctly represented in the documentation. This type of control procedure would be represented using an IF/THEN conditional programming decision: if the customer's purchase meets certain conditional criteria then the discount is calculated. If the customer's purchase does not meet the conditional criteria then the discount is not calculated.

Identifying and evaluating this type of control procedure requires the auditor or programmer to examine associations and perceive relationships in the data: the amount of the customer's purchase, the conditional criteria for applying the discount, the relationship between the customer's purchase and the criteria, the programming action taken if the purchase meets the criteria, and the programming action taken if the purchase does not meet the criteria, etc. Accordingly, the review of this type of control is a spatial task and, based upon the theory of cognitive fit, would best be supported by application documentation that is spatial in nature (e.g., application flowcharts).

In contrast, consider the review task that requires the auditor or programmer to simply identify and evaluate that the threshold criteria for applying a purchase discount is a certain, discreet value. For example, all purchases that exceed \$1,000 should receive a discount. Note that the auditor or programmer needs simply to determine if the criteria is or is not \$1,000. The auditor or programmer need not examine the relationship between data but only "extract" the discreet value from the application documentation to determine if it is or is not \$1,000. Accordingly, the review of this type of control is a symbolic task and, based upon the theory of cognitive fit, would best be supported by application documentation that is symbolic in nature (e.g., structured English). Consequently, the review of certain control procedures carried out by the auditor or programmer would be classified as a spatial review task, while the review of other control procedures would be classified as a symbolic review task.

In addition, certain application documentation could be classified as spatial and other application documentation would be classified as symbolic. For example, an application flowchart is akin to a graphical representation and is spatial in nature. In contrast, structured English is akin to a tabular representation and is symbolic in nature. Figure 1 illustrates short examples of the same underlying application procedure represented in both a flowchart and in structured English. Note that the symbols used in flowcharts inherently convey meaning. Hence, given the nature of the review task, the user can mentally eliminate all of those symbols that do not reflect that type of process, thus narrowing the field of candidate processes. For example, if the user were requested to identify a decision, he/she would immediately scan the flowchart for diamond symbols.

**FIGURE 1**  
**Flowchart and Structured English Representations of Conditional Looping**

**Flowchart – Spatial Representation:**

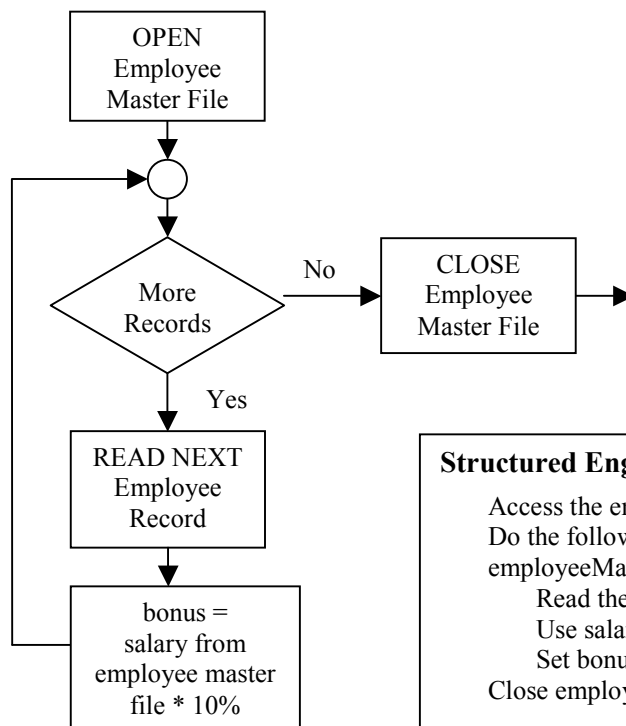

**Structured English – Symbolic Representation:**

Access the employeeMaster file for input.  
 Do the following steps while more records exist in the employeeMaster file:  
     Read the next record in the employeeMaster file.  
     Use salary from employeeMaster record.  
     Set bonus to salary \* 10%.  
 Close employeeMaster file.

Therefore, increasing the cognitive fit between the review task and the type of documentation should increase the efficiency and effectiveness of the review. This concept is represented in the following hypothesis:

**H1:** Documentation review performance will be enhanced when there is a matching of the review task with the application documentation.

In addition, a matching between the type of review task and type of documentation should also lead to higher perceived ease of use:

**H2:** Users will perceive a higher ease of use when there is a matching of the review task with the application documentation.

#### **IV. EXPERIMENTAL DESIGN AND METHODOLOGY**

##### **Overview**

A laboratory experiment was carried out to examine the hypotheses set forth above. Subjects were divided into two groups. One group received application documentation of a spatial nature (flowcharts), the second group received application documentation of a symbolic nature (structured English). The underlying information processing domain was identical across both treatment conditions. The subjects were required to carry out a review of the application documentation to identify and evaluate if control procedures were correctly represented in the application documentation. Half the control procedures required a spatial review task and half the required a symbolic review task. Performance was measured by accuracy in identifying and evaluating the control procedures represented in the application documentation and by the amount of time it took to complete the review task.

##### **Subjects**

Eighty-five sophomore level business students participated in the experiment. These students were enrolled in an undergraduate entry-level computer-programming course. The experiment was directly related to material on application code review that is covered in this course. As noted below, the subjects were evaluated on the material they completed during the experiment and 20% of their course grade was determined as a result of their performance on the various assignments they completed as part of the experiment. It should be noted that all communications and presentations to the subjects were made from a pre-written script to ensure completeness and uniformity.

Student subjects are appropriate for the current study for the following reasons: First, much prior work on the usability of user interfaces has used student subjects (most recently Arunachalam, Pei, and Steinbart (forthcoming) and Tuttle and Kershaw (1998)). This general consensus supports the notion that students are appropriate for this type of work (see Dickson et al. (1986) for a discussion of this. Also see Locke (1986)). Second, Ashton and Kramer (1980) concluded that in studies of decision-making, the decisions and underlying information processing behavior of students and primary decision makers were very similar. Third, it is important to note that this study is not concerned with the performance of decision makers in a professional context, rather, it is concerned with the decision processes associated with review task type and application documentation. Finally, and as noted later in this manuscript, the subjects were trained in the use of the alternative documentation types and completed two practice problem sets over several days to become competent and comfortable using the documentation (flowcharts or structured English) in order to conduct a review of control procedures (as will be reported later, the subjects did appear to become competent and comfortable using the documentation to review control procedures. The average accuracy of the subjects' responses during the measurement trials was 80/100 or 80%).

The experiment was carried out over three class periods. During the first class period the subjects completed a brief questionnaire that solicited background information including their name, age, gender, etc. Subjects were then randomly assigned to one of two groups. Subjects in one group remained in the current classroom while subjects in the second group were escorted to a similar classroom down the hall. Two of the authors were required to administer the experiment – one researcher remained with the first group while the other researcher escorted the second group to the similar classroom.

##### **Spatial Versus Symbolic Representations – Training and Practice**

Once separated, each group received a scripted presentation describing the form and function of application documentation. To examine the hypothesis, two forms of documentation were utilized in the experiment. One group received a presentation that described flowcharts (spatial representation) as a documentation tool. The other group received a presentation that described structured English (symbolic representation) as a documentation tool. Each

group also received instruction on how to examine documentation to identify and evaluate if a set of controls is represented in the documentation. The instruction included examples of various erroneous representations of controls and the corrected representation. The instruction was completed in about one hour.

At the end of the instruction, each group was assigned a problem set that was to be completed by the next class period. The problem set required the subjects to examine documentation to identify and evaluate a set of controls represented in application documentation. Those subjects who received training in flowcharts received documentation in the form of flowcharts while those subjects who received training in structured English received documentation in the form of structured English. In all other respects, the problem sets were identical. The subjects were instructed to complete the assignment in one sitting, to work alone, and to not discuss the assignment or the training with anyone. Appendix A includes copies of the two problem sets – one documented using flowcharts, the other documented using structured English.

The first problem set was collected at the beginning of the second class period. An answer key was then provided showing the correct answers to the first problem set. A second more complex problem set was then distributed to the subjects. The second problem set was collected at the beginning of the third class period at which time a key to the problem set was distributed. The subjects reviewed the solutions to the second problem set before completing the measurement trials. Both problem sets were graded and students received course points based upon their performance on the problem sets.

The purpose of assigning and grading the two practice problem sets was to ensure that the subjects became competent and comfortable using the documentation (flowcharts or structured English) to conduct a review of control procedures. Course points were earned from completing the problem sets to ensure that the subjects had proper incentive to perform well when completing the task.

### **Measurement Trial**

The experimental measurement trial began after the subjects reviewed their answers to the second problem set during the third class period of the experiment. The measurement trial was carried out in a computer lab and was implemented using a programmed data collection instrument that was distributed to the subjects on diskettes. Each subject was seated at a separate PC and completed the measurement trial by responding to questions that were presented to them on their PC screen. The data collection program captured each subject's responses and the time it took each subject to respond to each question. This data capturing approach provided several advantages. These include: (1) preventing subjects from examining or changing previous responses, (2) controlling order effects through complete randomization of questions, and (3) alleviating problems of non-responses (the computer program required subjects to respond to every prompt before continuing).

### **Review Task**

The task carried out was identical to that contained in the two problem sets and required the subjects to review application documentation to identify and evaluate if various control procedures were correctly represented in the documentation. The application documentation represented a customer billing application that generates customer invoices for a fictional city utility company (The City of Mayberry). The "City of Mayberry" provides its residents with water, sewer, garbage, and recycling services. The billing application generates invoices each month for both residential and commercial customers. A number of realistic billing calculations were included in the application including billing customers of different classes (residential and commercial) at different rates, charging different amounts for different services (water, sewer, garbage, and recycling), and the calculation of a tax surcharge on each invoice.

The application documentation was presented to the subjects in hard copy form. The subjects who were trained to use the flowchart representation (spatial representation) received the application documentation in the form of a flowchart and the subjects who were trained to use structured English (symbolic representation) received the application documentation in the form of structured English. Questions about the control procedures were displayed in random order on the PC screen. The subjects simply responded "Yes" or "No" when asked if a given control procedure was correctly represented in the documentation. Half of the control procedures were represented correctly in the documentation and half the control procedures were represented incorrectly in the documentation. Appendix B contains a sample of the documentation used for the measurement trial and Appendix C contains sample screens from the data collection program.

The measurement trial was administered as an in class examination and the subjects earned course points from completing the measurement trial. This ensured they had proper incentive to perform well when completing the task.

### Spatial Versus Symbolic Review Tasks

Consistent with the theory of cognitive fit, the review of some control procedures can be defined as a spatial task, whereas the review of other control procedures can be defined as a symbolic task. Therefore, cognitive fit suggests that performance will be enhanced when there is a matching of the review task with the application documentation (e.g., matching a spatial review task with spatial representation). Accordingly, control procedures were developed and seeded within the documentation so that half required a spatial review task and half required a symbolic review task. The control procedures were distributed throughout the documentation. A total of 12 control procedures requiring a spatial review task and a total of 12 control procedures requiring a symbolic review task were seeded in the documentation. Table 1 displays the types of control procedures that were included in the experimental documentation. The controls are classified as requiring either a spatial and symbolic review.

**TABLE 1**  
**Control Procedures Contained in the Application Documentation**  
**Whose Review is a Spatial or Symbolic Task**

<b>Control Procedures Whose Review is a Spatial Task</b>	<b>Description</b>	<b>Example from The Experimental Documentation</b>
<b>Sequence</b>	A list of computer instructions. The instructions are executed in the order listed.	Set custNoInput to value on meterForm. Set currentReading to value on meterForm. Access custMaster file for input.
<b>Decision</b>	Selection between two or more lists of computer instructions. Only one list of instructions is executed. The selection is made based on the status of a condition.	If custType from custMaster record = R, Then, Set totalSewer to 9.00. Set totalGarbage to (recycle + 5.00). Set waterPlant to 1.00. Otherwise, Perform "Nonresidential Billing" process. In any case,
<b>Iteration</b>	Repetition of a list of computer instructions. The list is repeated until a condition is false.	Do the following steps while more custMaster file records exist and custNoInput is not equal custNo from custMaster record: Read the next custMaster record from custMaster file. If custNoInput equals custNo from custMaster record, Then, Perform "Bill Customer" process. Otherwise, Do nothing.



**TABLE 1, CONTINUED**  
**Control Procedures Contained in the Application Documentation**  
**Whose Review is a Spatial or Symbolic Task**

<b>Control Procedures Whose Review is a Spatial Task</b>	<b>Description</b>	<b>Example from The Experimental Documentation</b>
<b>Discrete Values</b>	Set a memory location to a specific value.	Set totalWater to 100.
<b>Computation</b>	Evaluating an expression and storing the results in a memory location.	Set tier 6 to 0.0086 * (usage - 40000) .
<b>Aggregation</b>	Summing the content of several memory locations.	Set totalWater to tier1 + tier2 + tier3 + tier4 + tier6.

### Dependent Measures Collected

There were two primary dependent measures collected for each subject: accuracy, as measured by the percentage of correctly identified control procedures in the application documentation, and the average time it took to identify each control. The programmed data collection instrument automatically recorded measures of both accuracy and time for each subject. In addition, the subjects responded to a series of five questions after they completed the task to capture their perceptions of how easy the application documentation was to use. The responses were measured on seven-point Likert-like scale. The questions were adapted from Amer (1993) and Batra et al. (1990) and are standard questions used to capture perceptions of ease-of-use. The five questions used are presented in Appendix D.

## V. RESULTS AND ANALYSIS

### Summary Statistics

Table 2 displays summary statistics for the dependant measure of accuracy by documentation type. Accuracy was calculated for each subject by dividing the number of their correct responses by the number of possible correct responses. For example, there were a total of 12 control procedures whose review was a spatial task seeded in the documentation and, therefore, a total of 12 questions about those control procedures (one question for each control procedure whose review was a spatial task). If a given subject responded correctly to 8 of these questions, then their accuracy was calculated at 67%. An identical calculation was made for the 12 questions about the control procedures whose review was a symbolic task.

**TABLE 2**  
**Summary Statistics by Documentation Type – Hit Rate Accuracy in Percent**

<b>Documentation Type</b>				
<b>Review Task</b>	<b>Spatial (Flowchart)</b>	<b>Symbolic (Structured English)</b>	<b>F-Value</b>	<b>Pr &gt; F</b>
Spatial	70.28%	70.24%	0.00	0.9812
Symbolic	89.53%	90.48%	0.26	0.6143
<b>Total</b>	<b>79.94%</b>	<b>80.36%</b>	<b>0.06</b>	<b>0.8147</b>

Table 3 displays summary statistics for the dependant measure of the average time by documentation type. Average time was calculated for each subject by averaging the time it took each subject to answer all the questions for each type of review task (spatial or symbolic). For example, there were a total of 12 control procedures whose review was a spatial task seeded in the documentation and, therefore, a total of 12 questions about these control procedures (one question for each control procedure whose review was a spatial task). A given subject's average time was calculated by averaging the time it took the subject to review the documentation and answer all 12 questions. An identical calculation was made for the 12 questions about the control procedures whose review was a symbolic task.

**TABLE 3**  
**Summary Statistics by Documentation Type – Average Time in Seconds**

<b>Documentation Type</b>				
<b>Review Task</b>	<b>Spatial (Flowchart)</b>	<b>Symbolic (Structured English)</b>	<b>F-Value</b>	<b>Pr &gt; F</b>
Spatial	62.29 seconds	70.39 seconds	5.45	0.0220*
Symbolic	40.30 seconds	44.99 seconds	4.86	0.0302*
<b>Total</b>	<b>102.59 seconds</b>	<b>115.38 seconds</b>	8.16	0.0054*

\* Two-tailed test significant at  $\alpha = 0.05$

As can be seen from Tables 2 and 3, there appears to be no difference in accuracy between the two types of documentation across the two types of review tasks. There is, however, a difference in the average time taken to complete each type of task between the two types of documentation. The analysis of this data is reported in the following sections.

### Identification of a Covariate

A covariate is a term that relates to or varies with the predictor (independent) variables. Covariates are used to control for factors we cannot control experimentally (Harris, 1975). As noted above, the measurement trial was administered as an in-class examination in a similar format to the mid-term examination given for the class. Therefore, we use the covariate of midterm scores to control for differences in academic performance. By controlling for differences in academic performance, we can more reliably perform between treatment comparisons. Several transformations of the mid-term time and accuracy were evaluated. The inverse of the time expended by subjects on their mid-term was the most effective in reducing the variability in the model.

### Multivariate Analysis

Before conducting a multivariate analysis, it was necessary to first verify that the homogeneity of regression assumption had not been violated. When testing this assumption, we discovered that there was no significant interaction between the independent variable (documentation type) and the covariate (inverse mid-term test taking time) with the dependent (task) variables ( $p=0.7453$ ). Therefore, since this assumption was not violated, it was possible to perform a MANCOVA to test the main hypotheses.

The multivariate Wilk's Lambda, Pillai's Trace, Hotelling-Lawley's Trace, and Roy's Greatest Root were all equivalent ( $F(2,80)=0.68$ ,  $p=0.5096$ ) and indicated significant differences on the total of the average time it took the subjects to complete the measurement exercise ( $p=0.0203$ ). This was followed by the conservative Tukey procedure that supported the significant differences in total test time at  $\alpha = 0.05$ . Hence, when controlling for mid-term test-taking time, subjects using the spatial documentation (flowchart) were faster than subjects using the symbolic documentation (structured English) ( $p=0.0054$ ) in completing the overall task.

On the other hand, there were no significant differences between the spatial documentation (flowchart) and symbolic documentation (structured English) in terms of overall accuracy – both treatment groups were equally as accurate on the overall task ( $p=0.8417$ ). The result of faster average times while maintaining the same level of accuracy for the spatial documentation (flowchart) was contrary to theory in that, the mismatches between representation and task should have offset each other given equal numbers of symbolic and spatial review tasks. As such, the hypothesis that there should be differences between those using the spatial documentation (flowcharts) and the symbolic documentation (structured English) unexpectedly did not hold in this case. Given multivariate significance, further univariate analyses were performed.

### Analysis of Symbolic Review Tasks

For all 12 symbolic review tasks required of the subjects, the mean time to complete any one task was 40 seconds (see Table 2) using the spatial documentation (flowcharts), whereas the mean for the symbolic documentation (structured English) was 45 seconds. This 12% difference in efficiency was found to be significant ( $p=0.0302$ ). Even more interesting, was the observation that this time differential was achieved without a significant loss in accuracy ( $p=0.6143$ ).

### Analysis of Spatial Review Tasks

For all 12 spatial review tasks required of the subjects, the mean time to complete any one task was 62 seconds (see Table 2) using the spatial documentation (flowcharts), whereas the mean for the symbolic documentation (structured English) was 70 seconds. This 13% difference in efficiency was found to be significant ( $p=0.0220$ ), again with no loss in overall accuracy ( $p=0.9812$ ).

### Analysis of Ease of Use

Finally, an overall score was calculated for the subjects' perception of ease of use by summing their responses to the five ease of use questions that appeared in the debriefing questionnaire (see Appendix D). The subjects responded to each question on a seven-point Likert-like scale. The scales were then converted and summed so that higher numbers indicate greater perceived ease of use. Therefore, the "best" possible overall ease of use score would be 35.

It was first important to assess the reliability of the scales. Researchers see the concept of reliability as fundamental to the valid use of self-report measures. Two forms of reliability or consistency are often considered. Test-retest reliability relates to an instrument's ability to provide the same or very similar results for the same people when they are tested on two or more different occasions, usually separated by sufficient time to reduce simple memorization of the test items and the responses given. This aspect of reliability has not been assessed in the current study. The second reliability measure relates to the internal consistency of the items that are grouped together within an instrument to form scales. If the items are indeed measuring the same overall construct, then one would expect the scores on each of the items to correlate both with each other and with the overall scale score. For such single dimensional additive scales, the generally preferred measure of internal scale reliability is Cronbach's alpha (Kline, 1993). Kline (1993) recommends a minimum standard of  $\alpha = 0.8$  for most psychometric instruments. Cronbach's alpha was calculated to be .850 for the five questions used in this study, all measuring ease-of-use, indicating an adequate level of internal consistency for the instrument.

The mean value of the overall score for the spatial documentation (flowcharts) was 20.51, whereas the mean value of the overall score for the symbolic documentation (structured English) was 16.75. A two-tail t-test on the overall ease of use scores showed that this was a statistically significant difference ( $p < .01$ ). Therefore, the spatial documentation (flowcharts) was perceived to be easier to use by the subjects.

## VI. DISCUSSION AND CONCLUSIONS

This paper reports the results of an experiment carried out to examine the usability of alternative forms of information systems documentation to determine those that best support documentation review to identify and evaluate if control procedures were correctly represented in the documentation. The results indicate that subjects using the spatial representation (flowcharts) took less time to complete the entire review task than the subjects using the symbolic (structured English) representation. There were, however, no differences in accuracy across the two representations. These results held for both spatial and symbolic review tasks. Results consistent with the theory of cognitive fit would reveal that the spatial review tasks would be best supported by a spatial representation (flowcharts) and the symbolic review tasks would be best supported by a symbolic representation (structured English). Thus the results are not consistent with the theory of cognitive fit. Similarly, those subjects using the spatial representation found it easier to use in completing the entire review. This result also held for both spatial and symbolic review tasks.

These results may be explained by the nature of the review task used in this research. One could posit that the review task carried out by the subjects may actually have consisted of two tasks: (1) physically locating a specific control, which is primarily a spatial task, and (2) carrying out an evaluation of the control, which can be either a spatial or symbolic task. It can also be posited that **most** of the mental processing is associated with the **first** of these tasks: physically locating a specific control. After the control is located the evaluation process (the second task) is relatively straightforward. Therefore, the advantages of using flowcharts during the first of the two tasks could swamp the advantages or disadvantages of either flowcharts or structured English during the second task. In this case, one would expect that subjects using flowcharts would complete both tasks of the review more quickly **and** perceive flowcharts to be easier to use for both types of tasks. Such were the findings reported above. Similar findings were also noted in a study of the effects of information presentation and judgment strategy on judgment performance, that showed there were no significant differences in accuracy between graphs (spatial) and tables (symbolic) (Tuttle and Kershaw 1998).

## **Limitations**

There are a few limitations of the experiment reported in this paper that should be noted. First, the experiment was conducted over several days. This was necessary to provide proper training of the subjects on the task. However, this multi-day approach could have resulted in some sharing of information between subjects. Second, the use of student subjects may raise questions about the validity of the results. The use of extensive training of the subjects in both the documentation used and the task completed was designed to address this issue. Although we recommend that caution should be exercised in generalizing the findings of this study, we would posit that the efficiency savings could be extended to a professional setting. For example, in a professional setting, an analyst or auditor is generally assigned to tasks that are of relative difficulty to his or her abilities. In the study at hand, students were assigned a relatively difficult task for their abilities. Hence, if task difficulty is relative to ability, one could make the presumption that the efficiency savings noted here, could also be achieved in a professional environment.

## **Implications for Practice**

This research has shown that, for organizations that choose to maintain system documentation, spatial or graphical representations prove to be the most efficient tool for auditors or programmers conducting a review of that documentation. This finding is consistent with previous research in database representations (Batra et al., 1990; Amer, 1993; Chan et al., 1993; Leitheiser and March, 1996). Although maintaining system documentation in narrative or symbolic form may not affect the accuracy of any application modifications and reviews, the results of this experiment clearly demonstrated this type representation significantly affects the time it takes to complete the task. Consequently, the more time, the greater the ultimate cost to the organization.

Research regarding the effectiveness and efficiency of alternative forms of application documentation is important not only to auditors seeking to carry out a review of application documentation but also for programmers and the developers of computer-aided software engineering (CASE) tools. Programmers carrying out maintenance tasks should be interested in discovering the most effective and efficient form of documentation to expedite their modification of existing systems. A more effective and efficient form of documentation should result in more effective and efficient application maintenance. In addition, the developers of CASE tools should be interested in the most effective and efficient documentation. If the costs of generating alternative forms of documentation are the same, then CASE tool developers should seek to generate the most effective and efficient form of documentation possible to increase the usefulness and marketability of their tools.

## REFERENCES

- Amer, T. S. 1991. An experimental investigation of the effects of multi-cue financial information display on decision making. *Journal of Information Systems* 5 (Fall): 18-34.
- \_\_\_\_\_. 1993. Entity-relationship and relational database modeling representations for the audit review of accounting applications: an experimental examination of effectiveness. *Journal of Information Systems* 7 (Spring): 1-15.
- Agarwal, R. and Sinha, A.P. 1996. Cognitive fit in requirements modeling: A study of object and process methodologies. *Journal of Management Information Systems*, 13 (Fall): 137-162.
- Arunachalam, V., B. K. W. Pei, and P. J. Steinbart. Forthcoming. Impression management with graphs: Effects on choices. *Journal of Information Systems*.
- Ashton, R. H., and S. S. Kramer. 1980. Students as surrogates in behavioral accounting research: some evidence. *Journal of Accounting Research* (Spring): 1-15.
- Batra, D., J. A. Hoffer, and R. P. Bostrom. 1990. Comparing representations with relational and EER models. *Communications of the ACM* 33, 2 (February): 126 - 139.
- Brooks, F. P. 1995. The mythical man-month: Essays on software engineering – Anniversary edition. Reading Massachusetts, Addison-Wesley.
- Chan, H.C.; Wei, K.K.; and Siau, K.L. 1993. User-database interface: the effect of abstraction levels on query performance. *MIS Quarterly* 17 (December): 441-464.
- Curtis, B., Sheppard S. B., Kruesi-Bailey, E., Bailey, J. and Boehm-Davis, D. A. 1989. Experimental Evaluation of Software Documentation Formats. *The Journal of Systems and Software* 9 (February): 167-207.
- Dickson, G. W., G. DeSanctis, and D. J. McBride. 1986. Understanding the effectiveness of computer graphics for decision support: a cumulative experimental approach. *Communications of the ACM* 29 (January): 40-47.
- Frownfelter-Lohrke, C. 1998. The effects of differing information presentations of general purpose financial statements on users' decisions. *Journal of Information Systems* 12 (Fall): 99 – 107.
- Galletta, D. F., Hartzel, K. S., Johnson, S. E., Joseph, J. L., and Rustagi, S., 1996/1997. Spreadsheet presentation and error detection: An experimental study. *Journal-of-Management Information Systems* 13 (Winter): 45-63.
- Harris, R. 1975. A primer of multivariate statistics. New York: Academic Press, Inc.
- Hutchins, E. L., J. D. Hollan, and D. A. Norman. 1985. Direct manipulation interfaces. *Human Computer Interaction* 1: 311-338.
- Jarvenpaa, S., and G. W. Dickson. 1988. Graphics and managerial decision making: research based guidelines. *Communications of the ACM* 31 (6): 764-774.
- Juhn, S.H., and Naumann, J.D. 1985. The effectiveness of data representation characteristics on user validation. *Proceedings of the 6th International Conference on Information Systems*, Indianapolis: 212-226.
- Kline, P. 1993. *A Handbook of Test Construction* (London, Routledge).
- Leitheiser, R.L., and March, S. T. 1996. The influence of database structure representation on database system learning and use. *Journal of Management Information Systems* 12 (Spring): 187-213.
- Locke, E. A. 1986. Generalizing from laboratory to field settings. Lexington, MA: Lexington Books.

- Shaft, T. M. and Vessey, I. 1998. The relevance of application domain knowledge: Characterizing the computer program comprehension process. *Journal of Management Information Systems* 15 (Summer): 51 – 78.
- Tuttle, B. M. and Kershaw, R. 1998. Information presentation and judgment strategy from a cognitive fit perspective. *Journal of Information Systems* 12 (Spring): 1 - 17.
- Vessey, I. 1991. Cognitive Fit: A theory-based analysis of the graphs versus tables literature. *Decision Sciences* 22: 219 – 240.
- \_\_\_\_\_. 1994. The effect of information presentation on decision making: A cost-benefit analysis. *Information & Management* 27: 103 – 119.
- Vessey, I., and D. Galletta. 1991. Cognitive Fit: An empirical study of information acquisition. *Information Systems Research* 2: 63 – 83.
- Weber, R. 1999. *Information Systems Control and Audit*. Upper Saddle River, NJ: Prentice Hall.
- Wilkinson, J., M. Cerullo, V. Raval, and B. Wong-On-Wing. 2000. *Accounting Information Systems*. New York: John Wiley and Sons Inc.

## APPENDIX A

This Appendix contains examples from the problem sets assigned to subjects in each treatment condition. A description of the algorithm is provided followed by both a flowchart (spatial) representation and a structured English (symbolic) representation and the questions to which the subjects responded.

### Algorithm

This algorithm contains a predefined process and a main module. The main module contains only sequential steps. The predefined process uses all three control-structures. Use the following requirements and algorithm to answer questions 1 through 8.

### Requirements for Algorithm 1

The algorithm displays a number in a currency format. The formatting is to be done in a predefined process, so the code can be reused. The predefined process expects the amount to be stored in `dblAmount` and the currency symbol to be stored in `chrSign`. The predefined process will put the formatted string in a variable called `txtCurrency`. The format will put commas and decimals in the number, put the currency symbol in front of the number, and round the number to hundredths. The trail zeros will not be added.

For this algorithm, you will need to recall what a modulus is. The modulus is the remainder after number is divided by divisor. The result has the same sign as divisor.

### Modulus Syntax

`MOD(number,divisor)`

*Number* - is the number for which you want to find the remainder.

*Divisor* - is the number by which you want to divide number. If divisor is 0, `MOD(number, 0)` returns an error.

### Modulus Examples

`MOD(321, 100)` returns the value 21             $(321/100 = 3 \text{ Remainder } 21)$

`MOD(2156798.33, 1000)` returns the value 798.33  
 $(2156798.33/1000 = 2156 \text{ Remainder } 798.33)$

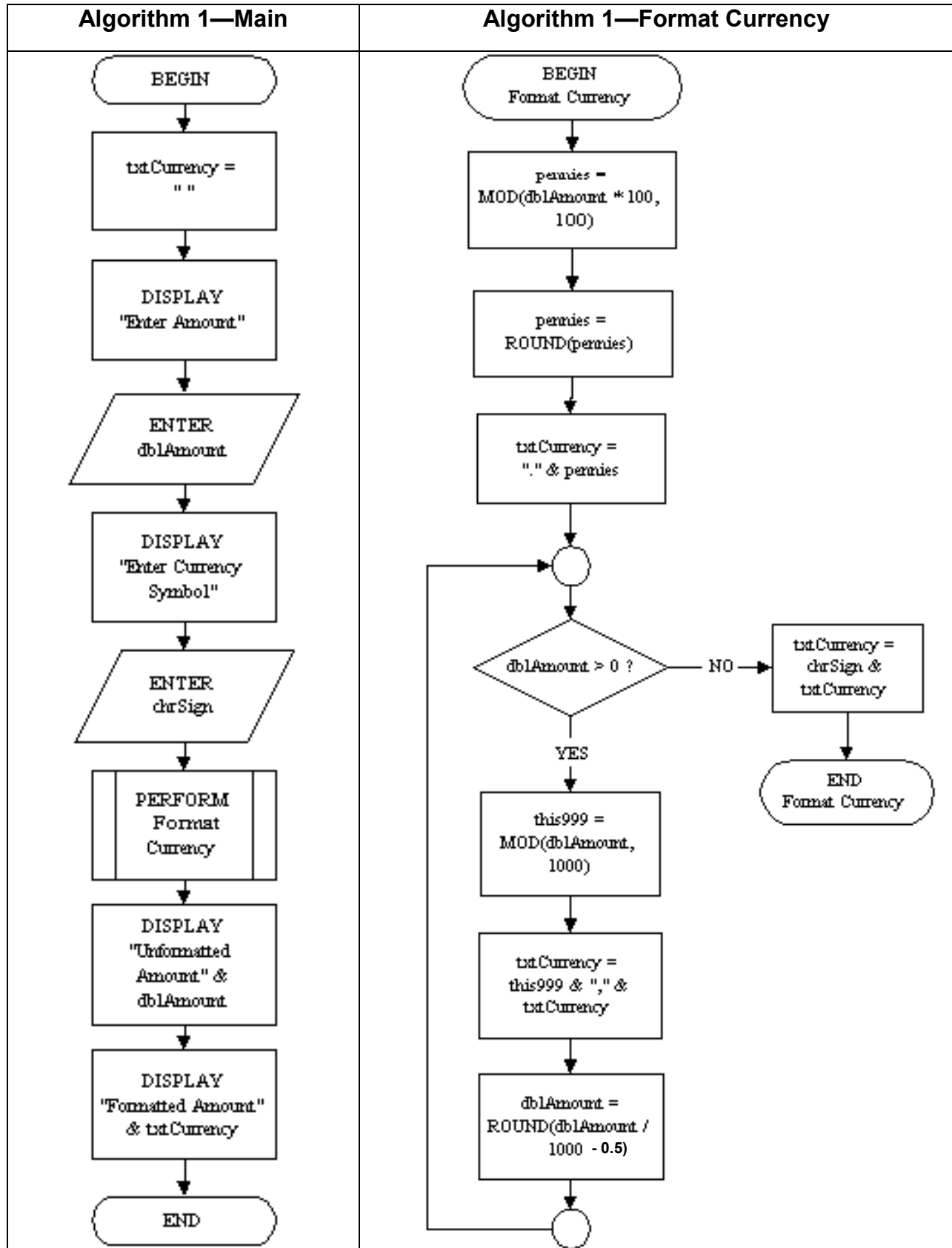



**Algorithm 1--Main**

```

=====
Set txtCurrency to "".
Set display to (display & "\nEnter amount: ").
Use dblAmount from keyboard.
Set display to (display & "\nEnter currency symbol: ").
Use chrSign from keyboard.
Perform the "Format Currency" process.
Set display to ("Unformatted amount: " & dblAmount).
Set display to (display & "\nFormatted amount: " & txtCurrency).
=====

```

**Algorithm 1—Format Currency**

```

=====
Set pennies to MOD(dblAmount * 100,100).
Set pennies to round(pennies).
Set txtCurrency to ( "." & pennies).
Set dblAmount to round(dblAmount).
Do the following steps while dblAmount > 0:
    Set this999 to MOD(dblAmount, 1000).
    Set txtCurrency to this999 & "," & txtCurrency.
    Set dblAmount to round(dblAmount / 1000.0 - 0.5).
Set txtCurrency to chrSign & txtCurrency.
=====

```

**Questions about Algorithm 1****Question 1**

Is dblAmount given the numeric value entered by the user?

- A. Yes.
- B. No.

**Question 2**

Is the remainder after dividing dblAmount by 1000 ever stored in this999?

- A. Yes.
- B. No.

**Question 3**

At any time, does pennies equal a hundred times dblAmount?

- A. Yes.
- B. No.

**Question 4**

Does txtCurrency ever equal the concatenation of “.” and the content of pennies?

- A. Yes.
- B. No.

**Question 5**

If the user entered “£” for the currency symbol and 1234567.8987 for the amount, would txtCurrency contain £1,234,567.9 when control returns to the main module? Assume the round function rounds up all unit values followed by 0.5 or more.

- A. Yes.
- B. No.

**Question 6**

Assuming the same input as in Question 5, would the main module display 1234567.8987 for the unformatted amount entered by the user?

- A. Yes.
- B. No.

**Question 7**

When the numeric value entered by the user is negative, is the amount enclosed in parentheses?

- A. Yes.
- B. No.

**Question 8**

Does the computation that divides dblAmount by a thousand and stores the results in dblAmount reduce the results of division by 0.5 to prevent rounding of numbers? For example, would 4999.0 become four rather than five?

- A. Yes.
- B. No.

## APPENDIX B

This Appendix contains examples of the measurement exercise. A description of the algorithm is provided followed by both a flowchart (spatial) representation and a structured English (symbolic) representation.

### Requirements for the Algorithm

The City of Mayberry provides its residents with water, sewer, garbage, and recycling services. Invoices are prepared each month for both residential and commercial customers using the Utilities Department Billing System.

Water billing for both residential and commercial customers is based upon actual consumption. Consumption is computed by comparing the current water meter reading against the prior month's reading - the difference being actual water usage for the current month. Customers are billed using a multi-tier system, whereby, the more water a customer uses, the more they are charged. Every customer pays at least the Tier 1 charge regardless of usage in order for the City to maintain the connection and treatment facilities. Residential customers are charged a flat monthly rate for a sewer connection. Similarly, residential customers pay flat monthly fees for garbage pick-up and recycling.

Commercial customers are classified into groups for sewer charges based upon the characteristics of what they discharge into the system. Each group is charged a flat rate. The lower the quality of the discharge, the higher the treatment cost and, hence, the higher the billing rate. Rather than a flat fee, commercial customers are billed monthly for garbage pick-up based upon the size and number of garbage cans or dumpsters that they use. The commercial customer may purchase their own containers or they may rent them on a monthly basis from the Utilities Department. Container rentals are included as part of the total monthly charge for garbage pick-up.

The city counsel recently approved a one-percent (1%) surcharge on both residential and commercial customers' total water billing to fund a new water treatment plant. For example, if a customer's monthly water bill is \$100, they would pay a \$1 surcharge for that month.

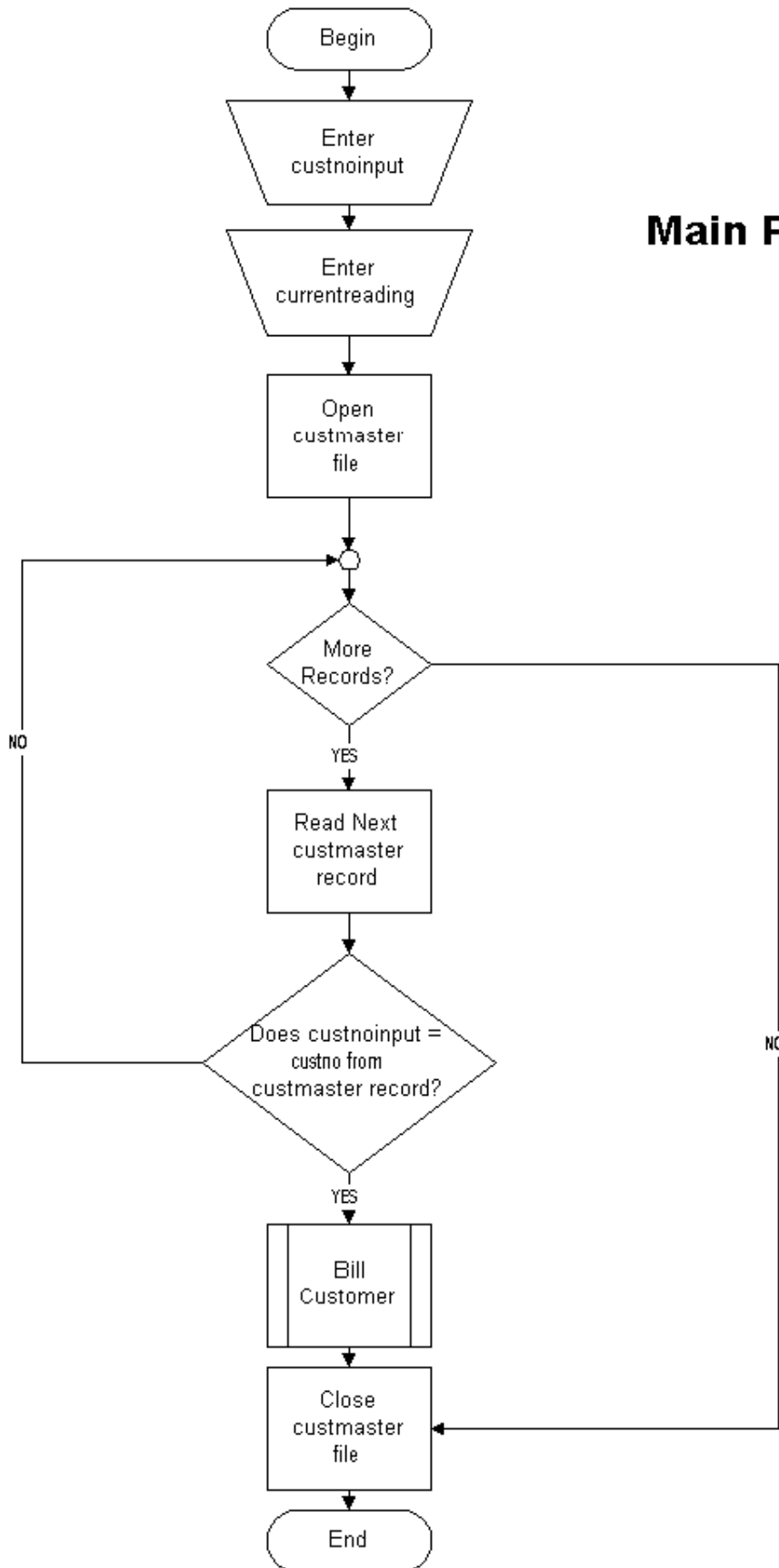

**Main Process**

## Bill Customer Process (PartA)

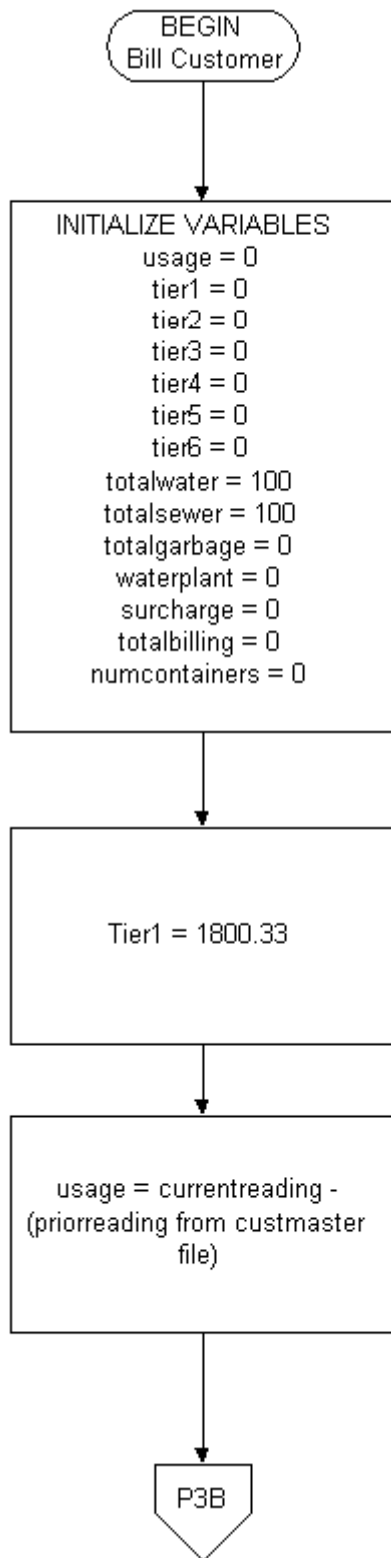

## Bill Customer Process (PartB)

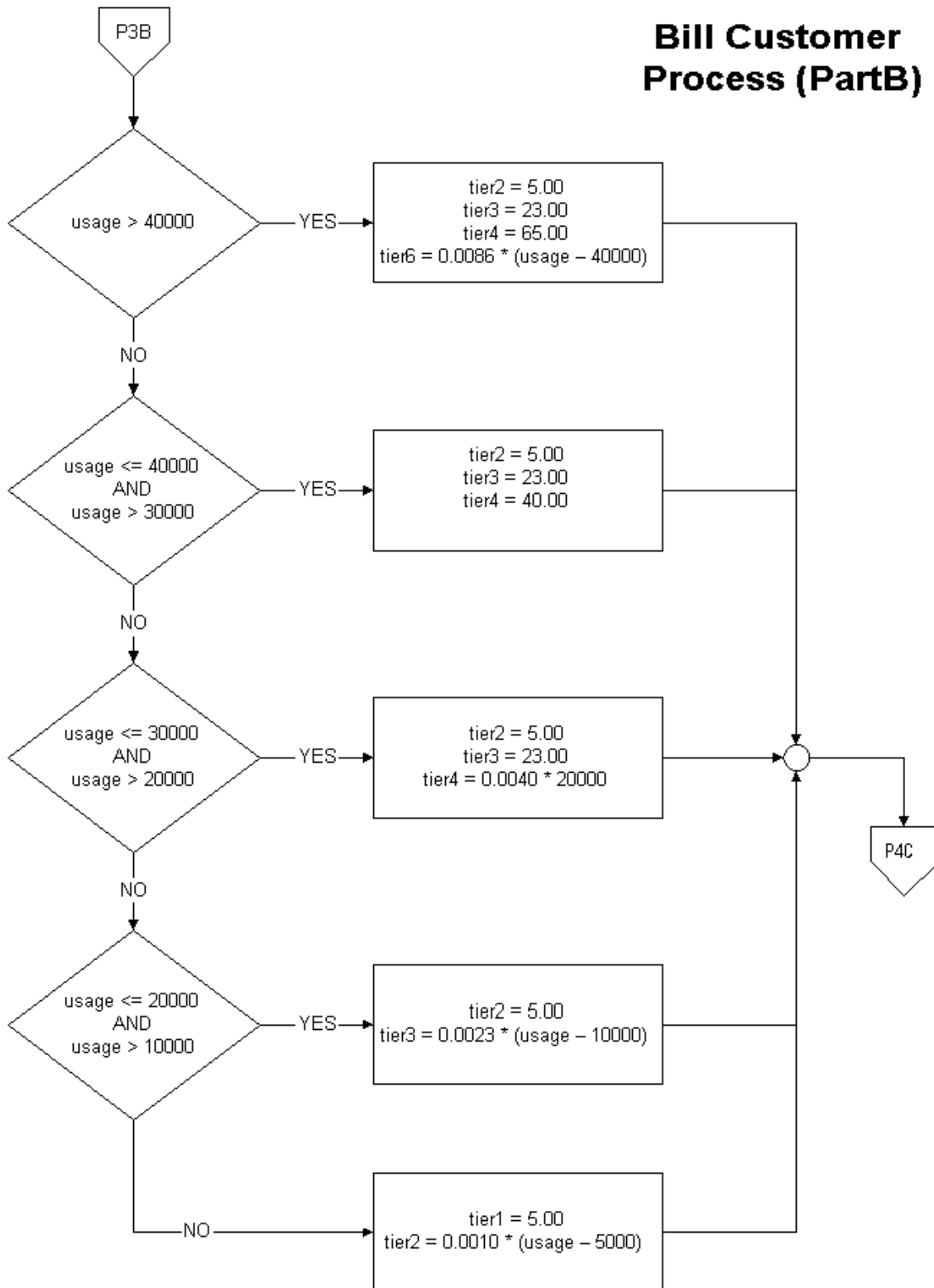

## Bill Customer Process (PartC)

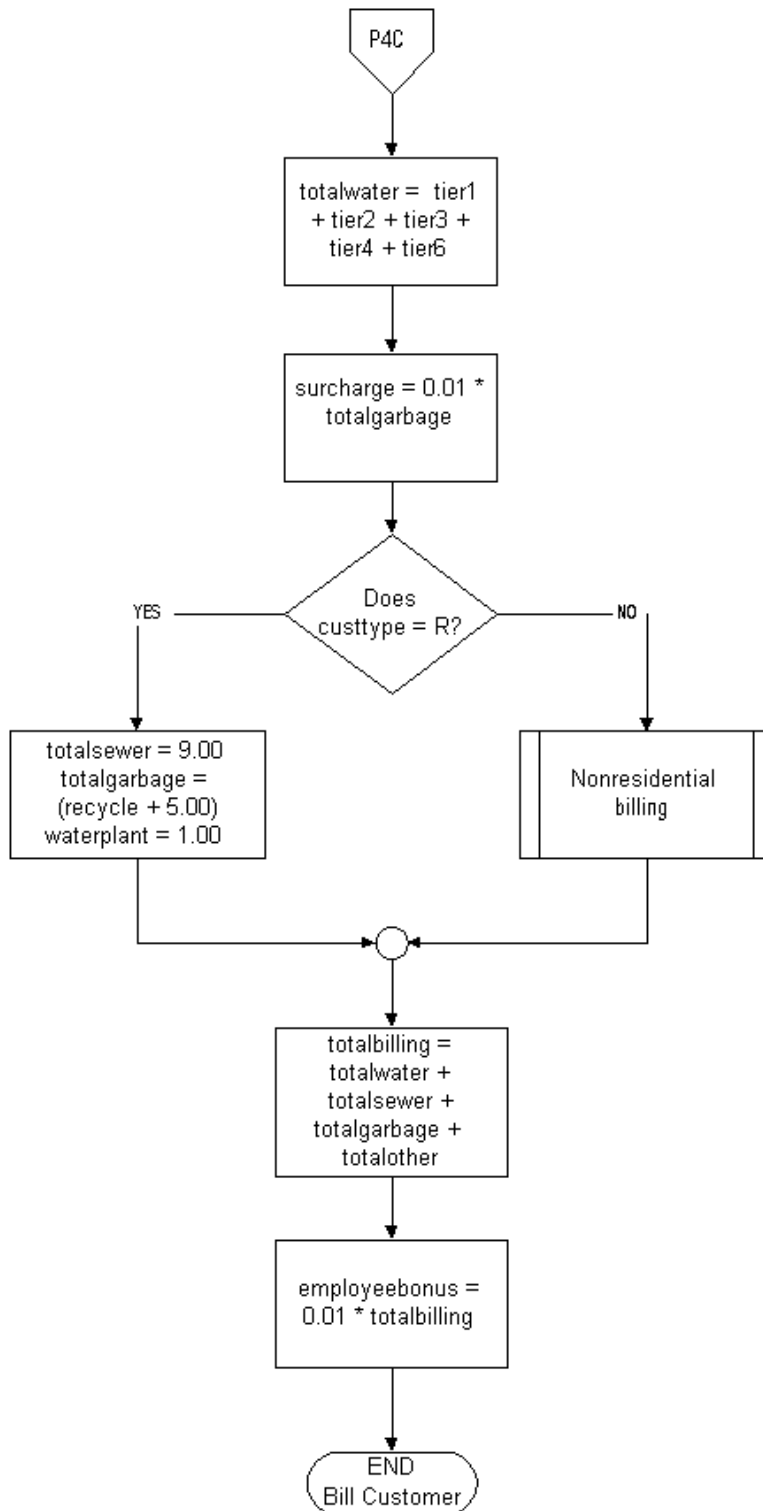

### Nonresidential Billing Process (Part A)

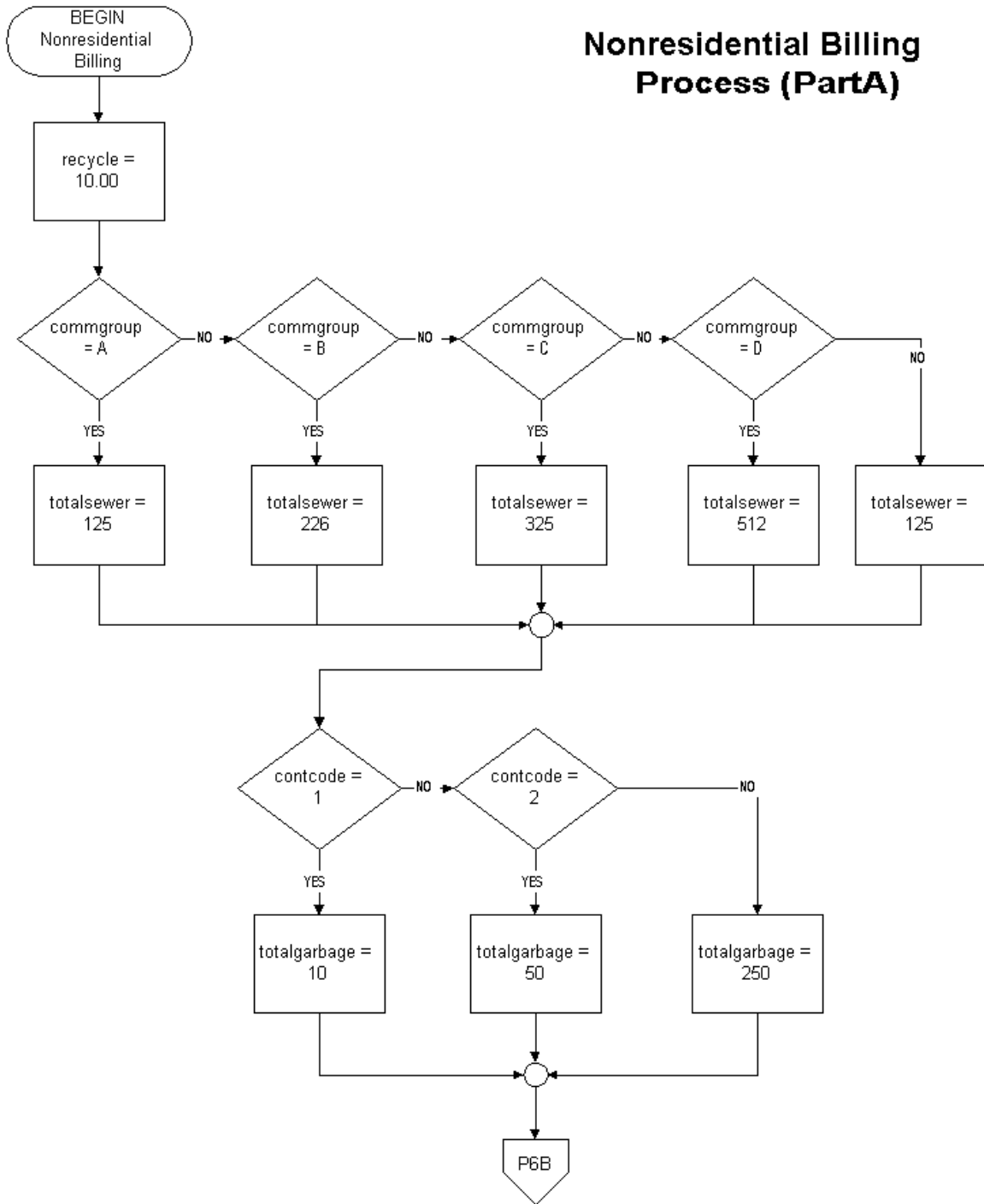



## Nonresidential Billing Process (PartB)

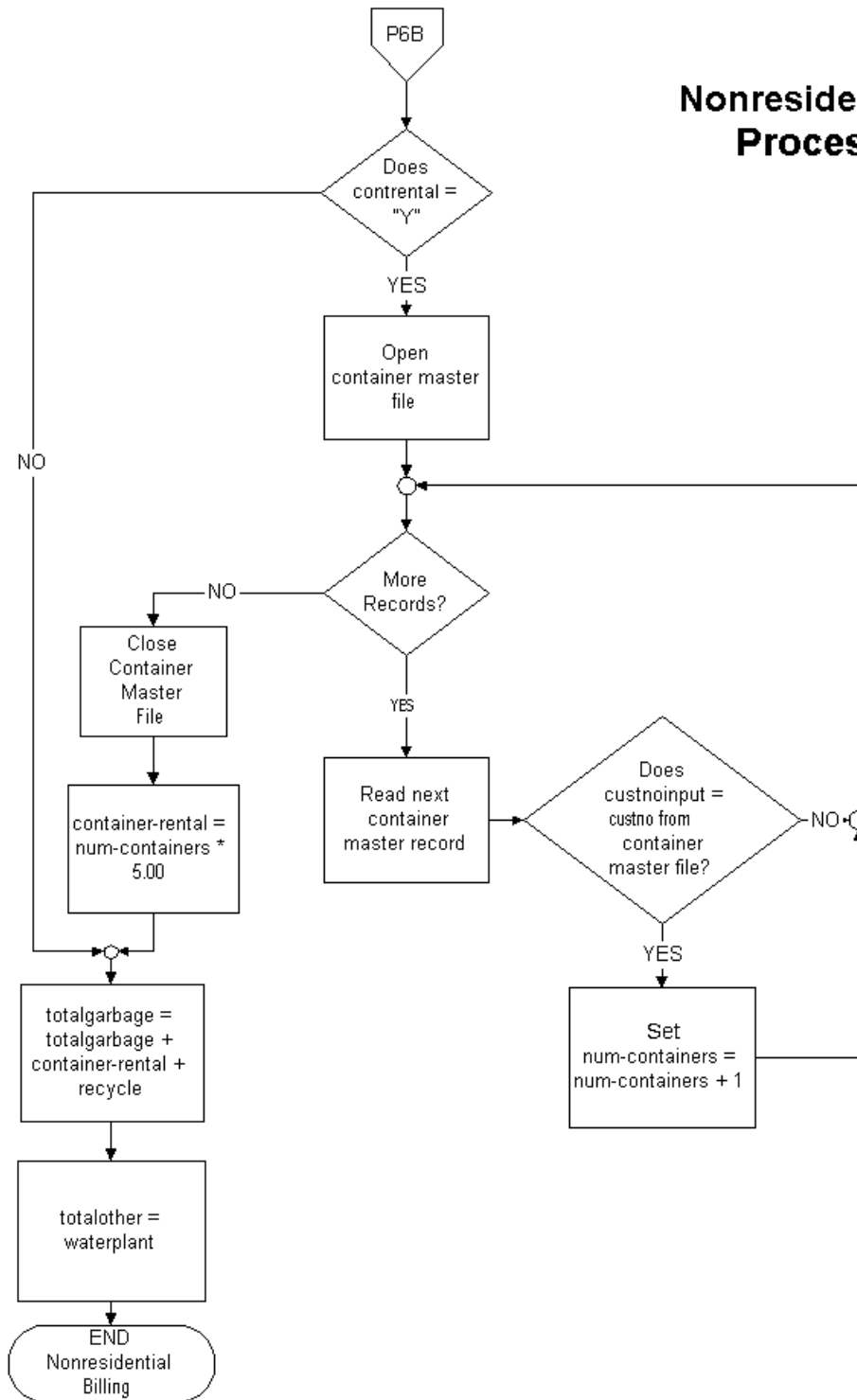

**Main Process for City of Mayberry Billing System**

```
=====
Set custNoInput to value on meterForm.
Set currentReading to value on meterForm.
Access custMaster file for input.
Do the following steps while more custMaster file records exist
and custNoInput is not equal custNo from custMaster record:
    Read the next custMaster record from custMaster file.
    If custNoInput equals custNo from custMaster record,
        Then,
            Perform "Bill Customer" process.
        Otherwise,
            Do nothing.
Close custMaster file.
=====
```

**Bill Customer Process for City of Mayberry Billing System**  
=====**Part A**

Set usage to 0.  
Set tier1 to 0.  
Set tier2 to 0.  
Set tier3 to 0.  
Set tier4 to 0.  
Set tier5 to 0.  
Set tier6 to 0.  
Set totalWater to 100.  
Set totalSewer to 100.  
Set totalGarbage to 0.  
Set waterPlant to 0.  
Set surcharge to 0.  
Set totalBilling to 0.  
Set numContainers to 0.  
Set tier1 to 1800.33.  
Set usage to currentReading - (priorReading from custMaster)  
    record.

**Bill Customer Process for City of Mayberry Billing System****Part B**

Select the case for usage that applies:

Case 1 (usage > 40000):  
Set tier2 to 5.00.  
Set tier3 to 23.00.  
Set tier4 to 65.00.  
Set tier 6 to  $0.0086 * (\text{usage} - 40000)$ .

Case 2 (30000 < usage <= 40000):  
Set tier2 to 5.00.  
Set tier3 to 23.00.  
Set tier4 to 40.00.

Case 3 (20000 < usage <= 30000):  
Set tier2 to 5.00.  
Set tier3 to 23.00.  
Set tier4 to  $0.0040 * 20000$ .

Case 4 (10000 < usage <= 20000):  
Set tier2 to 5.00.  
Set tier3 to  $0.0023 * (\text{usage} - 10000)$ .

Otherwise,  
Set tier1 to 5.00.  
Set tier2 to  $0.0010 * (\text{usage} - 5000)$ .

**Bill Customer Process for City of Mayberry Billing System**

**Part C**

```
Set totalWater to tier1 + tier2 + tier3 + tier4 + tier6.  
Set surcharge to 0.01 * totalGarbage.  
If custType from custMaster record = R,  
    Then,  
        Set totalSewer to 9.00.  
        Set totalGarbage to (recycle + 5.00).  
        Set waterPlant to 1.00.  
    Otherwise,  
        Perform "Nonresidential Billing" process.  
In any case,  
    Set totalBilling to totalWater + totalSewer + totalGarbage +  
        totalOther.  
Set employeeBonus to 0.01 * totalBilling.
```

=====

**Nonresidential Billing Process for  
City of Mayberry Billing System**

=====

**Part A**

Set recycle to 10.00.

Select the case for commGroup from the custMaster record that applies:

Case 1 (commGroup = A):

Set totalSewer to 125.

Case 2 (commGroup = B):

Set totalSewer to 226.

Case 3 (commGroup = C):

Set totalSewer to 325.

Case 4 (commGroup = D):

Set totalSewer to 512.

Otherwise,

Set totalSewer to 125.

Select the case for contCode from the custMaster record that applies:

Case 1 (contCode = 1):

Set totalGarbage to 10.

Case 2 (contCode = 2):

Set totalGarbage to 50.

Otherwise,

Set totalGarbage to 250.

**Nonresidential Billing Process for  
City of Mayberry Billing System**

**Part B**

```
If contRental from the custMaster record = Y,  
  Then,  
    Access the containerMaster file for input.  
    Do the following steps while more records exist in  
      containerMaster file:  
      Read the next containerMaster record.  
      If custNoInput = custNo from containerMaster  
        record,  
        Then,  
          Set numContainers to numContainers + 1.  
        Otherwise,  
          Do nothing.  
      Close containerMaster file.  
      Set containerRental to numContainers * 5.00.  
In any case,  
Set totalGarbage to totalGarbage + containerRental + recycle.  
Set totalOther to waterPlant.
```

=====

## APPENDIX C

This Appendix contains samples of the screens from the programmed data collection program.

**TRJ Evaluation**

This program asks questions that can be answered either "Yes" or "No". You are to check the option that corresponds to the answer you believe is correct. For example, "Do most dogs bark?" would be answered "Yes." You would click the "Yes" option and then click the "Done" button. Fill-in your name and group. Click the start button to begin.

Enter your name:  Group:

Question:

Answer

Yes

No

**TRJ Evaluation**

This program asks questions that can be answered either "Yes" or "No". You are to check the option that corresponds to the answer you believe is correct. For example, "Do most dogs bark?" would be answered "Yes." You would click the "Yes" option and then click the "Done" button. Fill-in your name and group. Click the start button to begin.

Enter your name:  Group:

Question:

**J. Doe, remember to click Yes or No before clicking Done.**

**This is a practice question. Do you understand that you are to click Yes or No, then click the Done button?**

Answer

Yes

No



**TRJ Evaluation**

This program asks questions that can be answered either "Yes" or "No". You are to check the option that corresponds to the answer you believe is correct. For example, "Do most dogs bark?" would be answered "Yes." You would click the "Yes" option and then click the "Done" button. Fill-in your name and group. Click the start button to begin.

**Enter your name:**  **Group:**

**Question:**

**J. Doe, remember to click Yes or No before clicking Done.**

**In the usage case selection are the conditions mutually exclusive? That is does a usage value satisfy one and only one condition?**

**Answer**

Yes

No

**TRJ Evaluation**

This program asks questions that can be answered either "Yes" or "No". You are to check the option that corresponds to the answer you believe is correct. For example, "Do most dogs bark?" would be answered "Yes." You would click the "Yes" option and then click the "Done" button. Fill-in your name and group. Click the start button to begin.

**Enter your name:**  **Group:**

**Question:**

**J. Doe, remember to click Yes or No before clicking Done.**

**Does employeebonus equal 1% of totalbilling?**

**Answer**

Yes

No

**TRJ Evaluation**

This program asks questions that can be answered either "Yes" or "No". You are to check the option that corresponds to the answer you believe is correct. For example, "Do most dogs bark?" would be answered "Yes." You would click the "Yes" option and then click the "Done" button. Fill-in your name and group. Click the start button to begin.

**Enter your name:**  **Group:**

**Question:**

**J. Doe, remember to click Yes or No before clicking Done.**

**When the custNoInput is not the last record in the containerMaster file, are all of the records read?**

**Answer**

Yes

No

**TRJ Evaluation**

This program asks questions that can be answered either "Yes" or "No". You are to check the option that corresponds to the answer you believe is correct. For example, "Do most dogs bark?" would be answered "Yes." You would click the "Yes" option and then click the "Done" button. Fill-in your name and group. Click the start button to begin.

**Enter your name:**  **Group:**

**Question:**

**J. Doe, remember to click Yes or No before clicking Done.**

**Does totaloher equal the sum of waterplant and surcharge?**

**Answer**

Yes

No

**TRJ Evaluation**

This program asks questions that can be answered either "Yes" or "No". You are to check the option that corresponds to the answer you believe is correct. For example, "Do most dogs bark?" would be answered "Yes." You would click the "Yes" option and then click the "Done" button. Fill-in your name and group. Click the start button to begin.

**Enter your name:**  **Group:**

**Question:**

**J. Doe, remember to click Yes or No before clicking Done.**

**When custtype is not 'R,' does totalgarbage equal the sum of totalgarbage and recycle?**

**Answer**

Yes

No

**TRJ Evaluation**

This program asks questions that can be answered either "Yes" or "No". You are to check the option that corresponds to the answer you believe is correct. For example, "Do most dogs bark?" would be answered "Yes." You would click the "Yes" option and then click the "Done" button. Fill-in your name and group. Click the start button to begin.

**Enter your name:**  **Group:**

**Question:**

**J. Doe, remember to click Yes or No before clicking Done.**

**Prior to processing individual cases, does tier1 equal 1,800.85?**

**Answer**

Yes

No

**TRJ Evaluation**

This program asks questions that can be answered either "Yes" or "No". You are to check the option that corresponds to the answer you believe is correct. For example, "Do most dogs bark?" would be answered "Yes." You would click the "Yes" option and then click the "Done" button. Fill-in your name and group. Click the start button to begin.

**Enter your name:**  **Group:**

**Question:**

**J. Doe, remember to click Yes or No before clicking Done.**

Is recycle initialized to zero?

**Answer**

Yes

No

**TRJ Evaluation**

This program asks questions that can be answered either "Yes" or "No". You are to check the option that corresponds to the answer you believe is correct. For example, "Do most dogs bark?" would be answered "Yes." You would click the "Yes" option and then click the "Done" button. Fill-in your name and group. Click the start button to begin.

**Enter your name:**  **Group:**

**Question:**

**J. Doe, remember to click Yes or No before clicking Done.**

Does containerRental receive a value before the containerMasterFile is opened?

**Answer**

Yes

No

**TRJ Evaluation**

This program asks questions that can be answered either "Yes" or "No". You are to check the option that corresponds to the answer you believe is correct. For example, "Do most dogs bark?" would be answered "Yes." You would click the "Yes" option and then click the "Done" button. Fill-in your name and group. Click the start button to begin.

**Enter your name:**  **Group:**

**Question:**

**J. Doe, remember to click Yes or No before clicking Done.**

**Will a bill be generated for the last customer in the custMaster file rather than the record for custNoInput?**

**Answer**

Yes

No

**Evaluation Complete**

J. Doe, thank-you for your participation.

## APPENDIX D

This appendix contains the five ease of use questions completed by the subjects in the post experimental questionnaire.

**1. I found the structured English CUMBERSOME to use.**

1            2            3            4            5            6            7

Strongly Agree

Neutral

Strongly Disagree

**2. Using the structured English was FRUSTRATING.**

1            2            3            4            5            6            7

Strongly Agree

Neutral

Strongly Disagree

**3. Using the structured English required A LOT of MENTAL EFFORT.**

1            2            3            4            5            6            7

Strongly Agree

Neutral

Strongly Disagree

**4. Using structured English is CLEAR and UNDERSTANDABLE to me.**

1            2            3            4            5            6            7

Strongly Agree

Neutral

Strongly Disagree

**5. OVERALL, I found the structured English EASY to use.**

1            2            3            4            5            6            7

Strongly Agree

Neutral

Strongly Disagree