

Available online at www.sciencedirect.com

Radiation Physics and Chemistry 75 (2006) 913–919

**Radiation Physics
and
Chemistry**www.elsevier.com/locate/radphyschem

X-ray Cherenkov radiation under conditions of grazing incidence of relativistic electrons onto a target surface

A. Kubankin^a, N. Nasonov^{a,*}, V. Kaplin^b, S. Uglov^b, M. Piestrup^c, C. Gary^c^aLaboratory of Radiation Physics, Belgorod State University, 14 Studencheskaya str., Belgorod 308007, Russia^bNuclear Physics Institute, Tomsk Polytechnic University, P.O.Box 25, Tomsk 634050, Russia^cAdelphi Technology Inc., 2181 Park Boulevard, Palo Alto, CA 4306, USA

Abstract

X-ray Cherenkov radiation in the vicinity of the photoabsorption edge of a target is considered in this work. A possibility of substantial increase in the yield of emitted photons under conditions of grazing incidence of emitted electrons onto the target surface is shown. We discuss peculiarities in the process of X-ray Cherenkov radiation from a multilayer nanostructure as well as possibilities of focusing emitted X-rays with the use of grazing-angle optics.

© 2006 Published by Elsevier Ltd.

PACS: 78.70–g; 78.70.Ck

Keywords: Cherenkov X-rays; Absorption edge; Relativistic electrons

1. Introduction

The Cherenkov effect allows to produce soft X-rays in the vicinity of atomic absorption edges, where the medium refractive index may exceed unity (Bazylev et al., 1976). This theoretical prediction has been confirmed experimentally (Bazylev et al., 1981; Moran et al., 1990; Knulst et al., 2001, 2003, 2004). The obtained experimental results (Knulst et al., 2001, 2003, 2004) demonstrate a possibility to create an effective quasi-monochromatic X-ray source with intensity of the order of $\sim 10^{-3}$ photon/electron. On the other hand, the average angular density of emission from a possible X-ray Cherenkov source is not high because of both a large value of the Cherenkov emission angle and an angular spread of the Cherenkov photon flux close to

the hollow cone. The above-mentioned circumstances lead to the following question: how to increase the angular density for the discussed X-ray source?

Some possible ways to solve this problem are considered in our work theoretically. In Section 2, we discuss a possibility to increase the emission angular density by using grazing incidence of emitting electrons onto the target. The next section is devoted to a study of X-ray Cherenkov radiation from a multilayer nanostructure. A possibility to focus the Cherenkov photon flux is considered in Section 4 on the basis of grazing-angle optics. Our conclusions are presented in the last section.

2. Grazing-incidence Cherenkov radiation

Let us consider emission from relativistic electrons crossing a foil of an amorphous medium. This theoretical task is well known (see, for example, Garibian and

*Corresponding author. Tel.: +722 341 477;
fax: +722 341 629.

E-mail address: nnn@bsu.edu.ru (N. Nasonov).

Yang (1983)), so we can use general results presented in the cited work. We assume that the photoabsorption length $L_{ab} \approx 1/\omega\chi''(\omega)$ is less than the electron path L/φ in the target. Here χ'' is imaginary part of the dielectric susceptibility $\chi = \chi' + i\chi''$ of the target material, L is the thickness of the target, and $\varphi \ll 1$ is the grazing incidence angle. Then we arrive at a simple model: emission from a fast electron that moves out a semi-infinite absorbing target to vacuum, where the emitted photon flux is measured by an X-ray detector (see Fig. 1).

Since background in the small frequency range under study is mainly determined by transition radiation, we neglect a contribution of bremsstrahlung. In addition, we consider emission from electrons moving with a uniform velocity \mathbf{v} and thus assume that the multiple scattering angle $\Psi_{sc} \approx (\varepsilon_k/\varepsilon)\sqrt{L_{ab}/L_R}$ corresponding to a distance of the order of L_{ab} is small relative to the characteristic angle $\sqrt{\chi'(\omega)}$ of the Cherenkov cone. Here ε is the electron energy, $\varepsilon_k \approx 21$ MeV, and L_R is the radiation length.

A solution to the considered task is well known (Garibian and Yang, 1983), so we put here only a final result for the emission distribution at small angles:

$$\frac{d^3E}{d\omega d^2\Theta} = \frac{16e^2}{\pi^2} \frac{\chi'^2 + \chi''^2}{(\Theta_x + \tau')^2 + \tau''^2} \times \frac{(\gamma^{-2} + \Theta_y^2 + \Theta_x^2 - \varphi^2)^2 + 4\varphi^2\Theta_y^2}{\Omega_{(-)}^2\Omega_{(+)}^2} \times \frac{\varphi^2\Theta_x^2}{(\gamma^{-2} + \Theta_y^2 + \Theta_x^2 + \varphi^2 - 2\varphi\tau')^2 + 4\varphi^2\tau''^2}, \quad (1)$$

where γ is the electron Lorentz factor,

$$\tau' = \frac{1}{\sqrt{2}} \sqrt{\sqrt{(\Theta_x^2 + \chi')^2 + \chi''^2} + \Theta_x^2 + \chi'},$$

$$\tau'' = \frac{1}{\sqrt{2}} \sqrt{\sqrt{(\Theta_x^2 + \chi')^2 + \chi''^2} - \Theta_x^2 - \chi'},$$

$$\Omega_{(\pm)} = \gamma^{-2} + \Theta_y^2 + (\varphi \pm \Theta_x)^2,$$

and $\Theta = \mathbf{e}_x\Theta_x + \mathbf{e}_y\Theta_y$ is the observation angle in the direction of \mathbf{n} (see Fig. 1). An influence of multiple

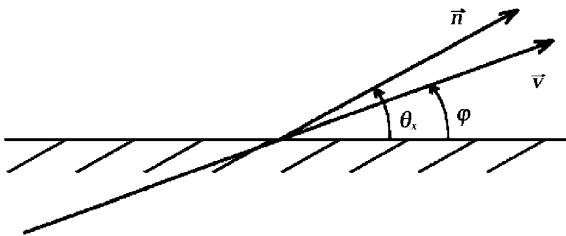

Fig. 1. Geometry of the process of Cherenkov radiation. \mathbf{n} is the unit vector in the direction of the emitted photon, \mathbf{v} is the velocity of the emitting electron, and φ is the incidence angle.

scattering is neglected in Eq. (1) for simplicity. This influence has been studied by Gary et al. (2005).

Formula (1) describes the spectral-angular distribution of emission and allows to study its dependence on the incidence angle φ . The distribution (1) apparently contains a maximum (Cherenkov maximum) determined by the condition

$$\gamma^{-2} + \Theta_y^2 + \Theta_x^2 + \varphi^2 - 2\varphi\tau' = 0,$$

which can be recast as

$$\gamma^{-2} - \chi' + \Theta_y^2 + (\varphi - \sqrt{\Theta_x^2 + \chi'})^2 = 0, \quad (2)$$

in the most interesting frequency range of anomalous dispersion before the absorption edge. In this range, χ'' is usually much less than χ' , so that $\tau' \approx \sqrt{\Theta_x^2 + \chi'}$ and $\tau'' \approx \frac{1}{2}\chi''/\sqrt{\Theta_x^2 + \chi'}$. In accordance with (2), Cherenkov radiation can be realized if $\chi' - \gamma^{-2} > 0$. This is well-known Cherenkov threshold in the X-ray range.

Let us consider the angular structure of the Cherenkov peak versus the orientation angle φ . For large enough angles $\varphi \gg \sqrt{\chi'} > \gamma^{-1}$, the distribution of emission intensity over the azimuthal angle of the Cherenkov cone is uniform in accordance with the asymptotic formula

$$\frac{d^3E_0}{d\omega d^2\Theta} = \frac{e^2}{\pi^2} \frac{\Theta_y^2 + (\varphi - \Theta_x)^2}{(\gamma^{-2} + \Theta_y^2 + (\varphi - \Theta_x)^2)^2} \times \frac{\chi'^2}{(\gamma^{-2} - \chi' + \Theta_y^2 + (\varphi - \Theta_x)^2)^2 + \chi''^2}, \quad (3)$$

that follows from (1). On the other hand, the distribution (1) becomes strongly non-uniform in the range of small angles $\varphi \sim \sqrt{\chi'}$. In order to show this in some detail, let us compare the maximum of the asymptotic distribution (3)

$$\left. \frac{d^3E_0}{d\omega d^2\Theta} \right|_{\max} = \frac{e^2}{\pi^2} \frac{\chi' - \gamma^{-2}}{\chi''^2},$$

with that of the general distribution (1),

$$\left. \frac{d^3E^{(\pm)}}{d\omega d^2\Theta} \right|_{\max} = \frac{e^2}{\pi^2} \frac{\chi' - \gamma^{-2}}{\chi''^2} \frac{4}{\varphi^2} \left(\frac{1}{\varphi \pm \sqrt{\chi' - \gamma^{-2}}} + \frac{1}{\sqrt{(\varphi \pm \sqrt{\chi' - \gamma^{-2}})^2 - \chi'}} \right)^{-2}. \quad (4)$$

It follows from Eq. (2) that maxima (4) is realized at the observation angles $\Theta_y = 0$,

$$\Theta_x = \Theta_{x\max}^{(\pm)} = \sqrt{(\varphi \pm \sqrt{\chi' - \gamma^{-2}})^2 - \chi'}. \quad (5)$$

Note that the two maxima (4) exist together only at large enough incidence angles

$$\varphi > \sqrt{\chi'} + \sqrt{\chi' - \gamma^{-2}}.$$

At smaller φ , the Cherenkov cone begins to contact the target surface, so that only one maximum,

$$\left. \frac{dE^{(+)}}{d\omega d^2\theta} \right|_{\max}$$

is realized in the angular range

$$\sqrt{\chi'} - \sqrt{\chi' - \gamma^{-2}} < \varphi < \sqrt{\chi'} + \sqrt{\chi' - \gamma^{-2}},$$

just in accordance with Eq. (5). This maximum can exceed substantially the asymptotic value $e^2(\chi' - \gamma^{-2})/\pi^2\chi'^2$. The ratio

$$\left. \frac{d^3E^{(+)}}{d\omega d^2\theta} \right|_{\max} / \left. \frac{d^3E_0}{d\omega d^2\theta} \right|_{\max},$$

calculated with formula (4) for different values of the parameter $\gamma^2\chi'$ is presented in Fig. 2 as a function of φ .

Two main conclusions follow from Fig. 2. The discussed φ -dependence is close to the resonant one for emitting electrons of high enough energies ($\gamma^2\chi' \gg 1$). Therefore, it is necessary to choose the optimum value of the incidence angle φ very carefully. Enhancement in the emission angular density that is achievable under conditions of grazing incidence of emitting electrons on the target surface can be very substantial.

The effect of strong modification of the structure of the Cherenkov cone under the conditions considered is illustrated by Fig. 3 which shows the angular distribution of Cherenkov radiation for a fixed value of the emitted-photon energy.

Yield of Cherenkov X-ray radiation from the Be target was calculated in the present work by using formula (1) and the dielectric susceptibility $\chi(\omega) = \chi'(\omega) + i\chi''(\omega)$ determined experimentally by

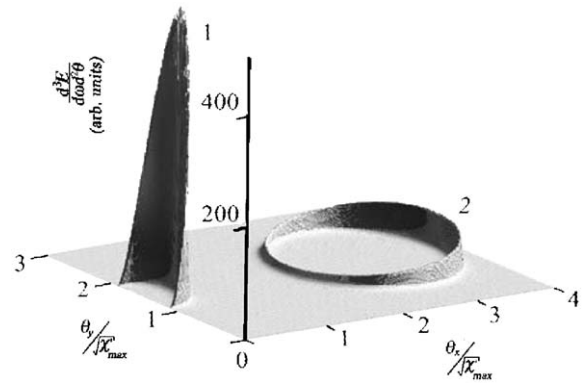

Fig. 3. Dependence of the Cherenkov cone structure on the incidence angle φ . Presented spectral-angular distributions of Cherenkov radiation have been calculated for Be target with parameters $\omega = 111.6$ eV, $1/\gamma\sqrt{\chi'_{\max}} = 0.4$, and $\chi'_{\max} = 0.05$. Distributions 1 and 2 correspond to $\varphi = 0.17\sqrt{\chi'_{\max}}$ and $\varphi = 3\sqrt{\chi'_{\max}}$, respectively.

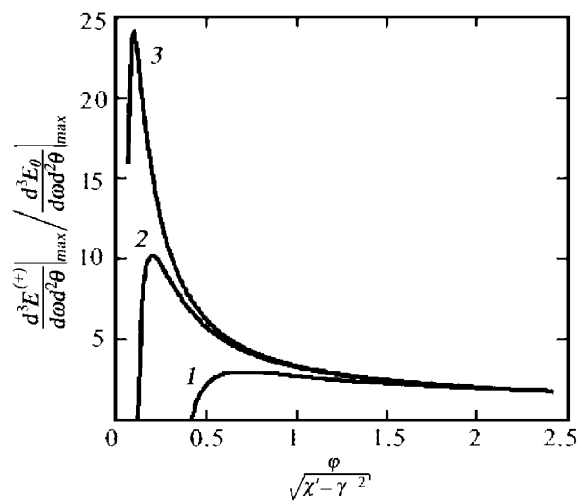

Fig. 2. Amplification factor for the Cherenkov angular density as a function of the incidence angle φ . The curves 1,2,3 correspond to the value of the parameter $\gamma^2\chi' = 2, 5, 10$, respectively.

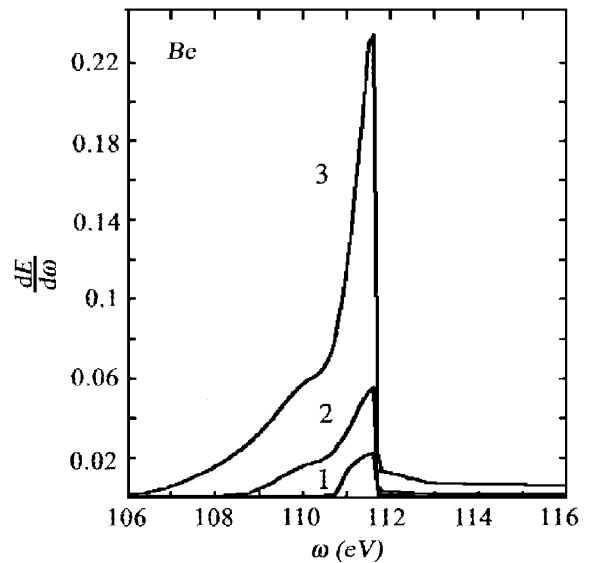

Fig. 4. Spectrum of Cherenkov radiation from Be target at different incidence angles φ . Curves have been calculated with the parameters $1/\gamma\sqrt{\chi'_{\max}} = 0.1$ and $\chi'_{\max} = 0.05$. Collimator angular sizes were $\Delta\theta_x = 0.3\sqrt{\chi'_{\max}}$ and $\Delta\theta_y = 0.3\sqrt{\chi'_{\max}}$. Curves 1, 2, and 3 correspond to $\varphi = 5\sqrt{\chi'_{\max}}$, $\varphi = 0.5\sqrt{\chi'_{\max}}$, and $\varphi = 0.05\sqrt{\chi'_{\max}}$, respectively.

Henke et al. (1993). Curves presented in Fig. 4 describe spectra of Cherenkov photons emitted from the Be target into a collimator of a finite angular size. In the performed calculations, the collimator center was placed at the angle corresponding to the maximum of the emission angular density. Angular size of the collimator was chosen in such a way that the emission yield passing through the collimator was close to saturation for small

incidence angles φ , when the emission angular distribution over the azimuthal angle is strongly non-uniform.

Presented curves demonstrate a substantial growth of the emission yield with a decrease of the incidence angle φ . This effect has a simple geometric interpretation (Knutst, 2004). As clear from Fig. 1, photon emitted at the angle $\Theta_{x\max}^{(+)} > \varphi$ has a path L_{ph} in the target which is shorter than the path $L_{el} \approx L/\varphi$ of the emitting electron. According to (5), difference between $\Theta_{x\max}^{(+)}$ and φ is small for large orientation angles $\varphi \gg \sqrt{\chi'}$, when the photon yield is formed by part of the electron inner trajectory having a size of the order of the absorption length $L_{ab} \approx 1/\omega\chi''$. However, in the case of small $\varphi < \sqrt{\chi'}$, the ratio $L_{el}/L_{ph} \sim L_{el}/L_{ab} \sim \Theta_{x\max}^{(+)}/\varphi$ increases substantially in accordance with (4). One can say that the useful part of the electron trajectory, and consequently the photon yield, increases.

3. Cherenkov X-rays from relativistic electrons crossing a multilayer nanostructure

Let us consider X-ray emission from relativistic electrons moving in a medium with a periodic dielectric susceptibility $\chi(\omega, \mathbf{r}) = \chi_0(\omega) + \sum_g \chi_g(\omega) e^{i(\mathbf{g}, \mathbf{r})}$. Under conditions of Bragg scattering of a fast electron by the Coulomb field of periodic heterogeneities of the medium, the angle between electron velocity \mathbf{v} and direction \mathbf{n} of emitted photons can be large. This feature allows to arrange an irradiated sample in the immediate vicinity of the source and consequently increase the photon density at the sample surface. In case of a one-dimensional structure consisting of alternative layers with thicknesses a and b and with susceptibilities $\chi_a(\omega)$ and $\chi_b(\omega)$, respectively, the quantities $\chi_0(\omega)$ and $\chi_g(\omega)$ are determined by the expressions

$$\begin{aligned} \chi_0(\omega) &= \frac{a}{T} \chi_a + \frac{b}{T} \chi_b, \\ \chi_g(\omega) &= \frac{1 - e^{i(\mathbf{g}, \mathbf{a})}}{igT} (\chi_a - \chi_b), \end{aligned} \quad (6)$$

where $T = a + b$ is the period of multilayer structure, $\mathbf{g} = \mathbf{e}_x g$, $g \equiv g_n = (2\pi/T)n$, $n = 0, \pm 1, \dots$, and \mathbf{e}_x is the normal to the target surface (see Fig. 5).

Embarking on a study of emission properties, one should note that only the Bragg scattering geometry can be realized in the case under consideration. Since soft X-rays are strongly absorbed in a dense medium, a simple model of semi-infinite multilayer nanostructure can be used for calculations. Willing to discuss only fundamental aspects of the problem, we shall restrict our consideration to a specific case of the emitting electron moving with a constant velocity. Using general results of Caticha (1989) and Nasonov et al. (2003), one can obtain the following expression for the spectral-angular

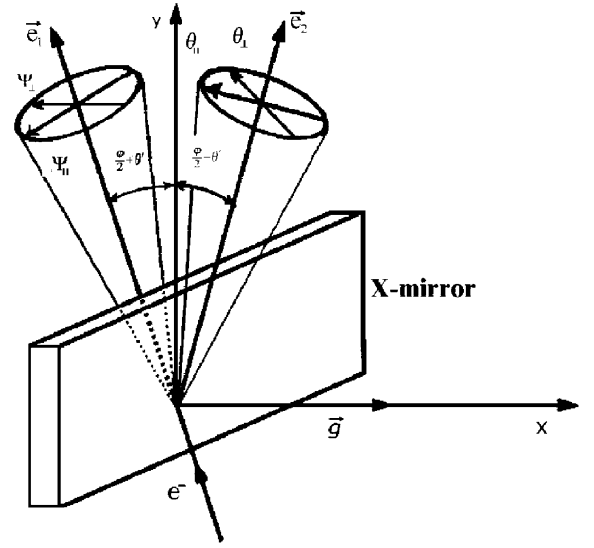

Fig. 5. Cherenkov X-ray radiation from a multilayer X-mirror. \mathbf{e}_1 is the axis of the emitting electron beam, \mathbf{e}_2 is the axis of the emitted photon flux, θ' is the orientation angle describing possible turning of the crystalline target by the goniometer, \mathbf{g} is the reciprocal lattice vector, Θ_{\parallel} and Ψ_{\parallel} are components of the angular variables Θ and Ψ parallel to the plane determined by the vectors \mathbf{e}_1 and \mathbf{e}_2 .

distribution of the emitted energy:

$$\begin{aligned} \frac{d^3 E}{d\omega d^2 \Theta} &= \sum_{\lambda=1}^2 |A_{\lambda}|^2, \\ A_{\lambda} &= \frac{e}{\pi} \Theta_{\lambda} \frac{(\chi'_g + i\chi''_g) \alpha_{\lambda}}{\Delta - \chi'_0 + \delta'_{\lambda} - i(\chi''_0 + \delta''_{\lambda})} \\ &\times \left[\frac{1}{\gamma^{-2} + \Theta^2 - \Delta - \delta'_{\lambda} + i\delta''_{\lambda}} - \frac{1}{\gamma^{-2} + \Theta^2} \right], \end{aligned} \quad (7)$$

where

$$\Delta = 2 \sin^2 \left(\frac{\varphi}{2} \right) \left[1 - \frac{\omega}{\omega_B} + (\theta' + \Theta_{\parallel}) \cot \frac{\varphi}{2} \right],$$

$$\alpha_1 = 1, \quad \alpha_2 = \cos \varphi,$$

$$\delta'_{\lambda} = \frac{\text{sign}(D_{\lambda})}{\sqrt{2}} \sqrt{\sqrt{C_{\lambda}^2 + D_{\lambda}^2} + C_{\lambda}},$$

$$\delta''_{\lambda} = \frac{1}{\sqrt{2}} \sqrt{\sqrt{C_{\lambda}^2 + D_{\lambda}^2} - C_{\lambda}},$$

$$C_{\lambda} = (\Delta - \chi'_0)^2 - (\chi_g'^2 - \chi_g''^2) \alpha_{\lambda}^2 - \chi_0''^2,$$

$$D_{\lambda} = 2[\chi_0''(\Delta - \chi'_0) + \chi_g' \chi_g'' \alpha_{\lambda}^2],$$

$$\Theta_1 = \Theta_{\perp}, \quad \Theta_2 = 2\theta' + \Theta_{\parallel}, \quad \Theta^2 = \Theta_1^2 + \Theta_2^2.$$

Also χ'_0 and χ''_0 are real and imaginary parts of the average dielectric susceptibility χ_0 , $\omega_B = g/[2 \sin(\varphi/2)]$ is the Bragg frequency, and

$$\begin{aligned} \chi'_g &= \pi^{-1} \sin(\pi a/T)(\chi'_a - \chi'_b), \\ \chi''_g &= \pi^{-1} \sin(\pi a/T)(\chi''_a - \chi''_b). \end{aligned}$$

Let us consider a parameter domain, in which the distribution (7) is maximum. To the moment, we neglect an influence of photoabsorption and take $\chi''_0 = \chi''_g = 0$. Then the equation that determines radiation maximum,

$$\gamma^{-2} + \Theta^2 - \Delta - \delta'_\lambda = 0,$$

or

$$\Delta_0 - \Delta' - \text{sign}(\Delta') \sqrt{\Delta'^2 - \chi_g^2 \alpha_\lambda^2} = 0,$$

$$\Delta_0 = \gamma^{-2} - \chi_0 + \Theta^2, \quad \Delta' = \Delta - \chi_0, \quad (8)$$

has the solution

$$\Delta' = \frac{\Delta_0^2 + \chi_g^2 \alpha_\lambda^2}{2\Delta_0}, \quad (9)$$

in two non-overlapping ranges of the parameter Δ_0 . The first of them is determined by the inequality

$$\Delta_0 > |\chi_g \alpha_\lambda|. \quad (10)$$

It corresponds to the branch of ordinary parametric X-ray radiation (PXR), including the contribution of diffracted transition radiation (DTR). Properties of PXR and DTR from relativistic electrons crossing a multilayer nanostructure with the negative average dielectric susceptibility $\chi_0(\omega) = -\omega_p^2/\omega^2$ have been studied in detail in our previous work (Nasonov et al., 2003).

The second branch is given by the inequality

$$\Delta_0 < -|\chi_g \alpha_\lambda|. \quad (11)$$

It corresponds to the Cherenkov branch of PXR. This radiation can only appear if the Cherenkov condition $\Delta_0 < 0$ is fulfilled.

Since $|\Delta'| > |\chi_g \alpha_\lambda|$ in accordance with (8), both the branches are realized outside the region of anomalous dispersion. Radiation corresponding to these branches can nevertheless appear inside the anomalous dispersion region $|\Delta'| < |\chi_g \alpha_\lambda|$ due to effects of photoabsorption. But the performed analysis showed that the yield of such radiation is small.

Let us estimate the greatest possible spectral-angular density for the discussed mechanism of emission. Assuming that $\chi'_0 \ll \chi'_g$, $\chi''_0 \ll \chi''_g$, one can obtain from (7) the following simple formula that describes the Cherenkov branch of PXR

$$\left(\frac{d^3 E_\lambda}{d\omega d^2 \Theta} \right)_{\max} \approx \frac{e^2}{\pi^2} \left(\frac{\chi'_g \alpha_\lambda}{\Delta_0} \right)^2 \left(\frac{\Theta_\lambda}{\delta'_\lambda} \right)^2, \quad (12)$$

where

$$\delta'_\lambda = \chi''_0 \left| \frac{\Delta_0^2 + (\chi'_g \alpha_\lambda)^2}{\Delta_0^2 - (\chi'_g \alpha_\lambda)^2} \right| - \chi'_g \alpha_\lambda \left| \frac{2\Delta_0 \chi'_g \alpha_\lambda}{\Delta_0^2 - (\chi'_g \alpha_\lambda)^2} \right|$$

and

$$\Delta_0 < -\chi'_g \alpha_\lambda \sqrt{1 - \left(2 \frac{\chi''_0 - \chi''_g \alpha_\lambda}{\chi'_g \alpha_\lambda} \right)^{2/3}} \approx -\chi'_g \alpha_\lambda.$$

Obviously, density (12) and that of ordinary Cherenkov radiation are of the same magnitude in the frequency range with $|\Delta_0| > |\chi'_g \alpha_\lambda|$. Thus, the discussed emission mechanism based on self-diffracted Cherenkov radiation generated in a multilayer nanostructure is indeed of interest for creation of X-ray sources.

The angular structure of the emitted photon flux calculated with the use of general formula (7) for a Be-C multilayer nanostructure is illustrated in Fig. 6. The period of nanostructure, T , and the orientation angle $\varphi/2$ have been chosen so that the Bragg frequency ω_B and the frequency at the maximum in real part of the dielectric susceptibility of Be are close to each other. Distribution presented in Fig. 6 has been calculated for fixed energies of emitting electrons and emitted photons. It is crucial for the purposes of X-ray source creation that the presented distribution is strongly non-uniform. This feature is analogous to that discussed in the previous section and it shows how to increase the yield of strongly collimated radiation.

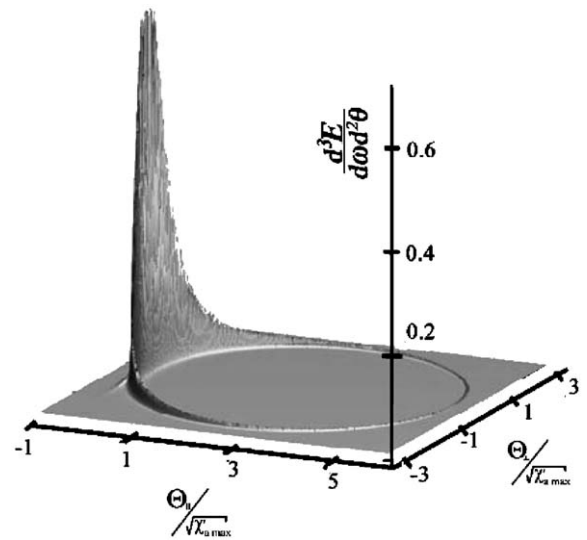

Fig. 6. Spectral-angular distribution of Cherenkov radiation from a multilayer X-mirror. Calculations are performed using the parameters $1/\gamma \sqrt{\chi'_{a \max}} = 0.2$, $\theta'/\sqrt{\chi'_{a \max}} = 0.7$, $\omega_B = \omega = 111.6 \text{ eV}$, $\varphi = 44^\circ$, $a/T = 0.9$, $\chi'_{a \max} = 0.05$ (beryllium).

4. On focusing Cherenkov X-rays with grazing-angle optics

Let us consider the next possibility to increase the angular density of Cherenkov radiation using the grazing-angle optics. Returning to the scheme described in Section 2, one should estimate a possible growth of the Cherenkov angular density which can be achieved using a simple cylindrical mirror placed on the in-vacuum side of the target so that the axis of the mirror coincides with the axis of the emitting electron beam. It is clear that, in the considered case, primary Cherenkov photons emitted from the target are focused on the point of the emitting-electron trajectory that lies at the distance $L_{\parallel} \approx 2R/(\Theta_{x\max}^{(+)} - \varphi)$ from the point where the electron leaves the target. Here R is the radius of the cylindrical X-mirror. The angles φ and $\Theta_{x\max}^{(+)}$ are defined as before.

Distribution of photons with a fixed energy in the image plane located perpendicular to the electron-beam axis at the above focus point has been calculated in the present work using geometric optics and usual expressions for the reflection coefficient that describes interaction of X-rays with the X-mirror. In order to facilitate a comparison of focused and non-focused photon beams, the calculated distribution was expressed in terms of observation angles identical to those describing the initial non-focused angular distribution of Cherenkov photons. Experimental values of real and imaginary parts of the X-mirror dielectric susceptibility have been used in the performed calculations. According to obtained results, the influence of photoabsorption in the X-mirror is very essential in the range of soft X-rays

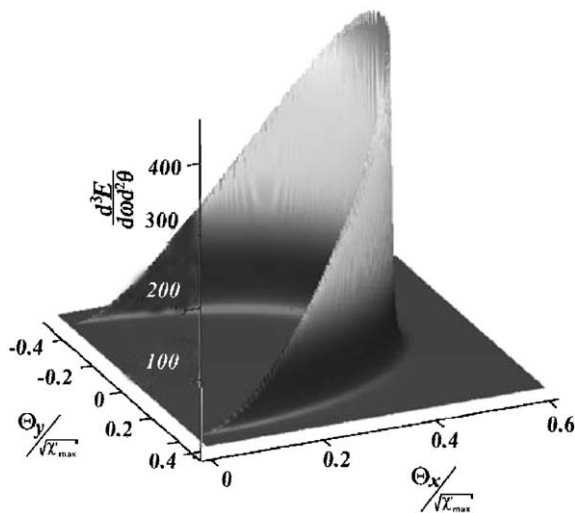

Fig. 7. Spectral-angular distribution of non-focused Cherenkov radiation from a Be target. Calculations have been done with the following parameters: $\omega = 111.6$ eV, $\gamma\sqrt{\chi_{\max}} = 0.1$, $\varphi = 0.1\sqrt{\chi_{\max}}$, $\chi_{\max} = 0.05$.

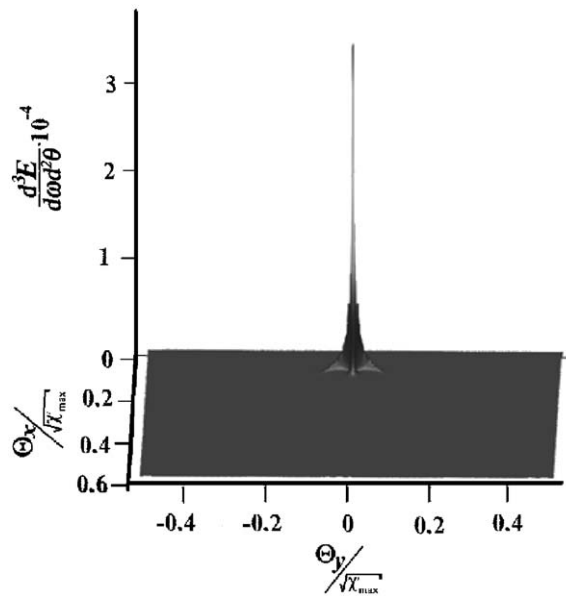

Fig. 8. Spectral-angular distributions of Cherenkov radiation from a Be target focused with a cylindrical carbon X-mirror. Parameters are the same as in Fig. 7.

under consideration. Therefore, X-mirrors consisting of light elements offer a few advantages over those made of heavy elements.

In our calculations, we considered a Cherenkov X-ray source with a beryllium radiator and a carbon X-mirror. Results of computations are shown in Figs. 7 and 8, where spectral-angular distributions for non-focused Cherenkov radiation and for the focused photon flux, respectively, are given. Obviously, the effect of X-ray focusing is very essential.

5. Conclusions

The performed studies of the process of Cherenkov X-ray radiation from relativistic electrons moving through a dense medium showed some possibilities to increase the angular density of emitted photons.

The emission angular density can be increased substantially under conditions of grazing incidence of emitting electrons on a target surface, when the structure of radiation in the Cherenkov cone is strongly modified. According to performed calculations, such an approach allows to achieve an enhancement by a factor of 10–50.

High photon density at the surface of an irradiated sample can be obtained with the use of a periodic nanostructure as a Cherenkov radiator. An advantage of this scheme consists in a possibility to generate Cherenkov X-rays at large angles relative to the emitting electron velocity and, consequently, to arrange the irradiated sample in the immediate vicinity of the

radiator. The performed analysis shows the possibility to obtain, in this scheme, the angular density of emitted photons close to that achievable in the ordinary scheme using a homogeneous radiator.

Substantial growth of the angular density of Cherenkov photons can be achieved by focusing emitted flux with the use of grazing-angle optics. In accordance with obtained numerical results, the emission density can be increased by the factor of ~ 100 in a simple scheme using a cylindrical X-mirror.

Acknowledgements

This work was supported by the United States National Institute for Health under Small Business Innovation Research (SBIR) program (grant 2-R33CA086545-02), by the United States National Science Foundation under the SBIR program (grant DMI-0214819), by the Russian Foundation of Basic Research (grant 04-02-16583), by Programs DOPFIN, University of Russia (grant 02.01.002), and by Ministry of Education and Science of Russia. One of the authors (AK) is grateful to Ministry of Education RF and Belgorod region Administration for financial support (grant GM-18/3).

References

- Bazylev, V., Glebov, V., Denisov, E., Zhevago, N., Khlebnikov, A., 1976. Cherenkov radiation as intense Röntgen source. *Pisma Zh. Eksp. Teor. Fiz.* 24 (7), 406–409 (JETP Lett. 24, 371) (in Russian).
- Bazylev, V., Glebov, V., Denisov, E., Zhevago, N., Kumakhov, M., Khlebnikov, A., Tsinoev, V., 1981. Röntgen Cherenkov radiation: theory and experiment. *Zh. Eksp. Teor. Fiz.* 81 (11), 1664–1680 (Sov. Phys. JETP 54, 884) (in Russian).
- Caticha, A., 1989. Transition-diffracted radiation and the Cherenkov emission of X-rays. *Phys. Rev. A* 40, 4322–4329.
- Garibian, G., Yang, C., 1983. X-ray Transition Radiation. Armenian Academy of Science, Erevan.
- Gary, C., Kaplin, V., Kubankin, A., Nasonov, N., Piestrup, M., Uglov, S., 2005. An investigation of the Cherenkov X-rays from relativistic electrons. *Nucl. Instr. Meth. Phys. Res. B* 227, 95–103.
- Henke, B., Gullikson, E., Davis, J., 1993. X-ray interactions: photoabsorption, scattering, transmission and reflection at $E = 50\text{--}30000\text{ eV}$, $Z = 1\text{--}92$. *At. Data Nucl. Data Tables* 54, 181 URL: <http://www-crxo.lbl.gov>.
- Knulst, W., Luiten, O., van der Wiel, M., Verhoeven, J., 2001. Observation of narrow band Si *L*-edge Cherenkov radiation generated by 5 MeV electrons. *Appl. Phys. Lett.* 79, 2999–3001.
- Knulst, W., van der Wiel, M., Luiten, O., Verhoeven, J., 2003. High-brightness, narrow band and compact soft X-ray Cherenkov sources in the water window. *Appl. Phys. Lett.* 83, 4050–4052.
- Knulst, W., 2004. Cherenkov radiation in the soft X-ray region: toward a compact narrow-band source. Ph.D. Thesis, Eindhoven.
- Knulst, W., van der Wiel, M., Luiten, O., Verhoeven, J., 2004. High-brightness compact X-ray source based on Cherenkov radiation. *Proc. SPIE Int. Soc. Opt. Eng.* 5196, 393.
- Moran, M., Chang, B., Schneider, M., Maruyama, X., 1990. Grazing-incidence Cherenkov X-ray generation. *Nucl. Instr. Meth. Phys. Res. B* 48, 287–290.
- Nasonov, N., Kaplin, V., Uglov, S., Piestrup, M., Gray, C., 2003. X-rays from relativistic electrons in a multilayer structure. *Phys. Rev. E* 68, 036504, 7 pp.