

CHARACTERIZATION OF CYCLICALLY FULLY COMMUTATIVE ELEMENTS IN FINITE AND AFFINE COXETER GROUPS

MATHIAS PÉTRÉOLLE

ABSTRACT. An element of a Coxeter group is fully commutative if any two of its reduced decompositions are related by a series of transpositions of adjacent commuting generators. An element of a Coxeter group is cyclically fully commutative if any of its cyclic shifts remains fully commutative. These elements were studied by Boothby *et al.* In particular the authors precisely identified the Coxeter groups having a finite number of cyclically fully commutative elements and enumerated them. In this work we characterize and enumerate those elements according to their Coxeter length in all finite and all affine Coxeter groups by using an operation on heaps, the cylindric closure. In finite types, this refines the work of Boothby *et al.*, by adding a new parameter. In affine type, all the results are new. In particular, we prove that there is a finite number of cyclically fully commutative logarithmic elements in all affine Coxeter groups. We also study the cyclically fully commutative involutions and prove that their number is finite in all Coxeter groups.

INTRODUCTION

Let W be a Coxeter group. An element $w \in W$ is said to be *fully commutative* (FC) if two reduced words representing w can be transformed into each other only using commutation relations, that is relations of the form $st = ts$. These elements were introduced and studied independently by Fan in [5], Graham in [7] and Stembridge in [13, 14, 15]. In particular, Stembridge classified the Coxeter groups with a finite number of fully commutative elements and enumerated them in each case. Fully commutative elements appear naturally in the context of (generalized) Temperley–Lieb algebras, as they index a linear basis of those objects. Recently, in [1], Biagioli, Jouhet and Nadeau refined Stembridge’s enumeration by counting fully commutative elements according to their Coxeter length in any finite or affine Coxeter group.

In this paper, we focus on a certain subset of fully commutative elements, the *cyclically fully commutative* (CFC) elements. These are elements w for which every cyclic shift of any reduced expression of w is a reduced expression of some FC element (not necessarily the same as w). They were introduced by Boothby *et al.* in [3], where the authors classified the Coxeter groups with a finite number of CFC elements (they showed that they are exactly the groups with a finite number of FC elements) and enumerated them. The main goal of [3] was to establish necessary and sufficient conditions for a CFC element $w \in W$ to be logarithmic, that is to satisfy $\ell(w^k) = k\ell(w)$ for any positive integer k . This is the first step towards

Key words and phrases. Cyclically fully commutative elements, Coxeter groups, generating functions, affine Coxeter groups, heaps.

studying a cyclic version of Matsumoto's theorem, which says that two reduced words representing the same element in W can be transformed into each other only using braid relations. Here we will focus on the combinatorics of CFC elements. We introduce an operation on heaps which we will call *cylindric closures* and which, roughly speaking, adds relations between some maximal and minimal points in a heap H , as was done in a more general setting in [4]. This will allow us to give a new characterization of CFC elements in all Coxeter groups (see Theorem 1.14). For finite or affine Coxeter groups, this characterization can be reformulated in terms of words by using the work from [1]. From this, we will be able to enumerate the CFC elements by taking into account their Coxeter length. We will also prove that the number of CFC involutions is finite in all Coxeter groups.

This paper is organized as follows. We recall in Section 1 some definitions and properties of Coxeter groups. Then we introduce the aforementioned cylindric closure of heaps, and deduce a new characterization of CFC elements in terms of pattern-avoidance for these cylindric closures. In Section 2, we use this characterization to obtain a complete classification (in terms of words) of CFC elements in the affine type \tilde{A}_{n-1} . We also deduce a classification of CFC elements in type A_{n-1} , and use this to enumerate CFC elements according to their Coxeter length in both types. The same work is done for the types \tilde{C}_n , B_n , D_{n+1} , \tilde{B}_{n+1} , and \tilde{D}_{n+2} in Section 3. In Section 4, we will focus on CFC involutions. The main result is that there is a finite number of CFC involutions in all Coxeter groups. We also give a characterization of CFC involutions for all Coxeter groups and enumerate them according to their Coxeter length in finite and affine types. We end the paper in Section 5 by a few questions.

1. CYCLICALLY FULLY COMMUTATIVE ELEMENTS AND HEAPS

1.1. Cyclically fully commutative elements. Let W be a Coxeter group with finite generating set S and Coxeter matrix $M = (m_{st})_{s,t \in S}$. Recall (see [2]) that this notation means that the defining relations between generators are of the form $(st)^{m_{st}} = 1$ for $m_{st} \neq \infty$, where the matrix M is symmetric with $m_{ss} = 1$ and $m_{st} \in \{2, 3, \dots\} \cup \{\infty\}$. The pair (W, S) is called a *Coxeter system*. We can write, for any pair (s, t) of distinct generators, the relations as $sts \cdots = tst \cdots$, each side having length m_{st} ; these are usually called *braid relations* when $m_{st} \geq 3$. When $m_{st} = 2$, this is a *commutation relation* or a *short braid relation*. We define the Coxeter diagram Γ associated with (W, S) as the graph with vertex set S , and edges labelled m_{st} between s and t for each $m_{st} \geq 3$. As is customary, edge labels equal to 3 are usually omitted.

For $w \in W$, the *Coxeter length* $\ell(w)$ is the minimal length of any expression (or word) $\mathbf{w} = s_1 \dots s_n$ with $s_i \in S$ such that the element corresponding to \mathbf{w} is w . For clarity, we will write w for elements in W , and \mathbf{w} for expressions. An expression is called *reduced* if it has minimal length. The set of all reduced expressions of w will be denoted by $R(w)$. A classical result in Coxeter group theory, known as Matsumoto's theorem (see [2, Theorem 3.3.1]), is that any expression in $R(w)$ can be obtained from any other one using only braid relations. An element w is said to be *fully commutative* if any expression in $R(w)$ can be obtained from any other one using only commutation relations. We will often abbreviate the term fully commutative by FC in the rest of the paper.

This proposition is not true for non FC elements. For example, in the Coxeter group of type A_2 (see Figure 6 for the corresponding Coxeter diagram), the element w having $\mathbf{w} = s_1 s_2 s_1$ as a reduced expression is not FC. Indeed, we have $\mathcal{L}(H_{s_1 s_2 s_1}) = \{s_1 s_2 s_1\}$ while $\mathcal{R}(w) = \{s_1 s_2 s_1, s_2 s_1 s_2\}$.

A chain $i_1 \prec \cdots \prec i_m$ in a poset H is *convex* if the only points u satisfying $i_1 \preceq u \preceq i_m$ are the points i_j of the chain. Notice that if a chain $i_1 \prec \cdots \prec i_m$ is convex, then we have $i_1 \prec_c \cdots \prec_c i_m$. The next result characterizes *FC heaps*, namely the heaps representing the commutativity classes of FC elements.

Proposition 1.3. [13, Proposition 3.3] *A heap H is the heap of some FC element if and only if the two following conditions are satisfied:*

- (i) *there is no convex chain $i_1 \prec_c \cdots \prec_c i_{m_{st}}$ in H such that $s_{i_1} = s_{i_3} = \cdots = s_{i_{m_{st}}}$ and $s_{i_2} = s_{i_4} = \cdots = t$ where $3 \leq m_{st} < \infty$, and*
- (ii) *there is no chain covering relation $i \prec_c j$ in H such that $s_i = s_j$.*

1.3. Cylindric closure of heaps and CFC elements. In this section, we fix a Coxeter system (W, S) . Now, we will focus on CFC elements. Before this, we need to define an operation on heaps, which we call the cylindric closure. Roughly speaking, the underlying idea is to add relations between some maximal and minimal points in a heap H , as was done in [4] in the more general context of hyperplane arrangements. Nevertheless, our approach in terms of cylindric closures fits more with our enumerative purpose, as we will encode the whole set of cyclic shifts of a reduced word by a unique diagram.

Definition 1.4. Let $H := H_{\mathbf{w}}$ be a heap of a word $\mathbf{w} = s_{a_1} \dots s_{a_\ell}$. The *cylindric closure* H^c of H is the labelling $i \mapsto s_{a_i}$ and a relation on the indices $\{1, \dots, \ell\}$, made of the chain covering relations \prec_c of H , together with some new chain covering relations defined as follows:

- for each generator s , consider the minimal point a and the maximal point b in the chain H_s (for the partial order \prec). If a is minimal and b is maximal in the poset H , and $a \neq b$, then add a new relation $b \prec_c a$.
- for each pair of generators (s, t) such that $m_{st} \geq 3$, consider the minimal point a and the maximal point b in the chain $H_{\{s, t\}}$ (for the partial order \prec). If these points have different labels (one is labelled s and the other is labelled t), then add a new relation $b \prec_c a$.

Example 1.5. For the simply laced linear Coxeter diagram with 7 generators, consider the word $\mathbf{w} = s_2 s_1 s_0 s_6 s_5 s_3 s_2 s_4 s_5 s_3 s_6$. The heap $H_{\mathbf{w}}$ and its cylindric closure $H_{\mathbf{w}}^c$ are represented in Figure 2.

Remark 1.6. The cylindric closure H^c is not a poset, even if we extend the relation \prec_c by transitivity. Indeed, each point in H^c would otherwise be in relation with itself.

The following definition naturally extends the definition of poset isomorphisms to cylindric closures.

Definition 1.7. Let H_1^c and H_2^c be two cylindric closures. They are *isomorphic* if there is a bijective map $f : H_1^c \rightarrow H_2^c$ which preserves the labelling and the relation \prec_c . In other words, if we denote by a_i (respectively b_i) the label of the point i in H_1^c (respectively H_2^c), then $a_i = b_{f(i)}$; and if i and j are two points of H_1^c , then $i \prec_c j \Leftrightarrow f(i) \prec_c f(j)$.

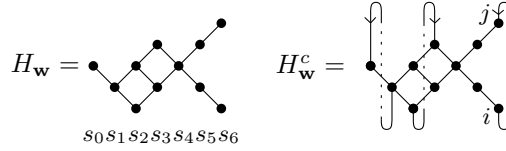

FIGURE 2. A heap and its cylindric closure. The dotted oriented edges correspond to the new relations we add in the definition of H_w^c . The orientation indicates that each point i on the bottom and each point j on the top connected by a dotted edge satisfy $j \prec_c i$.

Lemma 1.8. *Let H_1 and H_2 be two heaps. If $\varphi : H_1 \rightarrow H_2$ is a poset isomorphism preserving the labelling, then φ is also an isomorphism between H_1^c and H_2^c .*

Proof. The poset isomorphism φ preserves the maximality and the minimality of a point, as well as the labelling and the chain covering relations. It then follows from Definition 1.4 that φ , considered as a bijective map from H_1^c to H_2^c , also preserves the relation \prec_c . \square

As H^c is not a poset, we can not draw its Hasse diagram. Nevertheless, we define the *diagram* of H^c as the Hasse diagram of H , together with oriented edges representing the new relations described in Definition 1.4.

Let us explain the name “cylindric closure”. Consider the Coxeter system (W, S) corresponding to the linear Coxeter diagram Γ_n of Figure 3. The diagram of H^c should be considered on a cylinder as opposed to planar Hasse diagrams of heaps. On this cylinder, each chain H_s for a generator s can be seen as a circle.

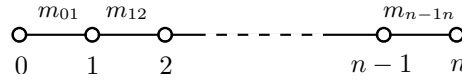

FIGURE 3. The linear Coxeter diagram.

If H^c is a cylindric closure of a heap, then the *size* $|H^c|$ is its cardinality. Given any subset $I \subset S$, we write H_I^c for the set of points in H^c with labels in I . Unlike in the definition of H_I , the set H_I^c does not include the relations \prec_c between those points.

Proposition 1.9. *Let w_1 and w_2 be two words. If w_2 is commutation equivalent to some cyclic shift of w_1 , then $H_{w_1}^c$ and $H_{w_2}^c$ are isomorphic.*

Proof. Let w_3 be a word which is commutation equivalent to w_2 and such that w_3 is a cyclic shift of w_1 . According to [13, Proposition 2.2], the heaps H_{w_3} and H_{w_2} are isomorphic. Then Lemma 1.8 ensures that there is an isomorphism between $H_{w_2}^c$ and $H_{w_3}^c$ preserving the labelling and the relation \prec_c . Therefore to finish the proof, it remains to prove that $H_{w_1}^c$ and $H_{w_3}^c$ are isomorphic.

First, we assume that w_3 is the left cyclic shift of w_1 , and we write $w_1 = sw$ and $w_3 = ws$, with a generator $s \in S$ and w an expression involving $\ell - 1 > 0$ generators. We will show that the cyclic permutation $f := (\ell, \ell - 1, \dots, 2, 1)$ is an isomorphism between $H_{w_1}^c = H_{sw}^c$ and $H_{w_3}^c = H_{ws}^c$.

The fact that f is bijective is immediate. We first show that f preserves the labelling. Let i be an integer between 1 and ℓ , and denote by a_i the labelling of the point i in $H_{\mathbf{w}_1}^c$ and by b_i the labelling of the point i in $H_{\mathbf{w}_3}^c$. We want to show that $b_{f(i)} = a_i$. We consider two cases. First, if $i = 1$, then $a_i = s$. By definition of f , we have $f(i) = \ell$, and by definition of \mathbf{w}_3 , we have $b_{f(i)} = b_\ell = s$. Second, if $i \neq 1$, then we have $f(i) = i - 1$. As $H_{\mathbf{w}_1}^c = H_{s\mathbf{w}}^c$ and $H_{\mathbf{w}_3}^c = H_{\mathbf{w}s}^c$, we have $a_i = b_{i-1}$, and thus $b_{f(i)} = a_i$.

Now we show that f preserves the relation \prec_c , that is if $1 \leq i, j \leq \ell$ are two points of $H_{\mathbf{w}_1}^c$, we have $i \prec_c j \Leftrightarrow f(i) \prec_c f(j)$. If $i = j$, the relation $i \prec_c i$ is not satisfied in $H_{\mathbf{w}_1}^c$, and the relation $f(i) \prec_c f(i)$ is not satisfied in $H_{\mathbf{w}_3}^c$. Otherwise, we have $i \neq j$, and we first show the direct implication. Let $1 \leq i, j \leq \ell$ be two distinct points in $H_{\mathbf{w}_1}^c$ such that $i \prec_c j$.

Assume that $i = 1$. The relation $1 \prec_c j$ is necessarily also satisfied in $H_{\mathbf{w}_1}$, as during the construction of $H_{\mathbf{w}_1}^c$, we only add relations of the form $j' \prec_c i'$ with $i' < j'$. Recall that we have $f(1) = \ell$ and $f(j) = j - 1$. We now have to examine whether 1 and j have the same label or not.

- If 1 and j have the same label, then this label must be s . Moreover, $1 \prec_c j$ implies by definition that j corresponds to the first occurrence of s in \mathbf{w} , and before this occurrence, all generator of \mathbf{w} commute with s . Thus the point $j - 1$ of $H_{\mathbf{w}_3}$ has label s and is minimal in the poset $H_{\mathbf{w}_3}$. As the point ℓ has label s and is maximal in $H_{\mathbf{w}_3}$, the step (i) of Definition 1.4 ensures that the relation $\ell \prec_c j - 1$ is satisfied in $H_{\mathbf{w}_3}^c$. Thus we have $f(1) \prec_c f(j)$.
- If j has label $t \neq s$, then $1 \prec_c j$ implies that j is minimal in $H_{\mathbf{w}_1}$ among all the points having label t . So $j - 1$ is also minimal in $H_{\mathbf{w}_3}$ among all the points having label t . As ℓ is maximal in $H_{\mathbf{w}_3}$ among all the points having label s , the step (ii) of Definition 1.4 ensures that the relation $\ell \prec_c j - 1$ is satisfied in $H_{\mathbf{w}_3}^c$. We then have $f(1) \prec_c f(j)$.

Assume now that $j = 1$. As $i > 1$, the relation $i \prec_c 1$ is not satisfied in $H_{\mathbf{w}_1}$. So this relation is added in $H_{\mathbf{w}_1}^c$ during the step (i) or (ii) of Definition 1.4. We have $f(i) = i - 1$ and $f(1) = \ell$. We consider two cases according to the label of i .

- If i has label s , we deduce that i is maximal in $H_{\mathbf{w}_1}$, and so $i - 1$ is maximal in $H_{\mathbf{w}}$. So there is a chain covering relation between the two last occurrences of s in $H_{\mathbf{w}_3}$. In other words, we have $f(i) = i - 1 \prec_c \ell = f(1)$ in $H_{\mathbf{w}_3} = H_{\mathbf{w}_3}$. This relation is also satisfied in $H_{\mathbf{w}_3}^c$.
- If i has label $t \neq s$, then i is maximal in $H_{s\mathbf{w}}$ among the points having label t . Therefore the relation $f(i) \prec_c f(1)$ is satisfied in $H_{\mathbf{w}_3}$, and also in $H_{\mathbf{w}_3}^c = H_{\mathbf{w}_3}^c$.

Finally, if $i, j \neq 1$, we immediately check that the relation $i - 1 \prec_c j - 1$ is satisfied in $H_{\mathbf{w}_3}^c$. This concludes the proof of $i \prec_c j \Rightarrow f(i) \prec_c f(j)$.

Conversely, by comparing this time the values of $f(i)$ and $f(j)$ with ℓ , the same discussion holds. This shows that f is an isomorphism between $H_{\mathbf{w}_1}^c$ and $H_{\mathbf{w}_3}^c$.

To conclude, if \mathbf{w}_3 is a general cyclic shift of \mathbf{w}_1 , we write $\mathbf{w}_1 = s_{a_1} s_{a_2} \cdots s_{a_\ell}$ and $\mathbf{w}_3 = s_{a_k} s_{a_{k+1}} \cdots s_{a_{k-1}}$ with $k \in \{2, \dots, \ell\}$. By using the above result, we successively prove that all the cylindric closures $H_{\mathbf{w}_1}^c = H_{s_{a_1} s_{a_2} \cdots s_{a_\ell}}^c$, $H_{s_{a_2} s_{a_3} \cdots s_{a_1}}^c$, \dots , $H_{s_{a_k} \cdots s_{a_{k-1}}}^c = H_{\mathbf{w}_3}^c$ are isomorphic. □

Now we aim to characterize CFC elements in terms of cylindric closures of heaps. For this we need to define the analogues of a chain and a convex chain in a heap for cylindric closures.

Definition 1.10. Let H be a heap and let H^c be its cylindric closure. Let m be a positive integer and let i_1, i_2, \dots, i_m be integers. We say that $i_1 \prec_c \dots \prec_c i_m$ is a *c-chain* in H^c if and only if the relations $i_k \prec_c i_{k+1}$ hold in H^c for all $k \in \{1, \dots, m-1\}$. The *length* of this c-chain is m . The c-chain is *proper* if all the integers i_j are distinct.

An illustration is given in Figure 4.

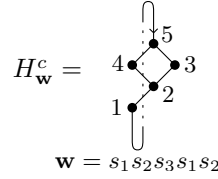

FIGURE 4. In $H_{\mathbf{w}}^c$, $1 \prec_c 2 \prec_c 4 \prec_c 5$ and $4 \prec_c 5 \prec_c 1 \prec_c 2$ are two different distinct proper c-chains of length 4, although they have the same points.

Definition 1.11. Let H be a heap and let s, t be two generators such that $m_{st} \geq 3$. Consider a proper c-chain $i_1 \prec_c \dots \prec_c i_m$ in H^c with $m \geq 3$ such that $s_{a_{i_1}} = s_{a_{i_3}} = \dots = s$ and $s_{a_{i_2}} = s_{a_{i_4}} = \dots = t$ (here m is not necessarily equal to m_{st}). Such a c-chain is called *cylindric convex* if the only proper c-chains $i_1 \prec_c u_1 \prec_c \dots \prec_c u_d \prec_c i_m$ in H^c are such that for all $\ell \in \{1, \dots, d\}$ we have $u_\ell \in \{i_2, \dots, i_{m-1}\}$.

Example 1.12. In the cylindric heap of Figure 4, the proper c-chain $1 \prec_c 2 \prec_c 4 \prec_c 5$ is not cylindric convex as we have $1 \prec_c 2 \prec_c 3 \prec_c 5$. The proper c-chain $4 \prec_c 5 \prec_c 1 \prec_c 2$ is cylindric convex.

Next, we prove the following lemma, which shows that cylindric convex c-chains naturally extend to cylindric closures the notion of convex chains in a heap.

Lemma 1.13. *Assume there exists a convex chain $i_1 \prec_c \dots \prec_c i_m$ of length $m \geq 3$ in a heap H , such that all points i_j are distinct and $s_{a_{i_1}} = s_{a_{i_3}} = \dots = s$ and $s_{a_{i_2}} = s_{a_{i_4}} = \dots = t$. Then this chain, considered as a (proper) c-chain, is also cylindric convex in the cylindric closure H^c .*

Proof. Let $i_1 \prec_c \dots \prec_c i_m$ be such a convex chain in H . Assume for the sake of contradiction that there is a proper c-chain $i_1 \prec_c \dots \prec_c i_k \prec_c u_1 \prec_c \dots \prec_c u_d \prec_c i_m$ in H^c , for an integer $k \in \{1, \dots, m-1\}$, with $u_1 \neq i_{k+1}$. Two cases can occur:

- Case 1. $i_k \neq i_{m-1}$: as i_k is not a maximal point among the points with label a_{i_k} (that is, i_k is not maximal in $H_{s_{a_{i_k}}}$), the relation $i_k \prec_c u_1$ holds in H . Consequently, the relation $i_k \prec_c u_1 \prec_c i_{k+2}$ holds in H . So $i_1 \prec_c \dots \prec_c i_m$ is not a convex chain in H , which is a contradiction.
- Case 2. $i_k = i_{m-1}$: as i_m is not a minimal point among the points with label a_{i_m} (that is, i_m is not maximal in $H_{s_{a_{i_m}}}$), the relation $u_d \prec_c i_m$ holds in H . Consequently, the relation $i_{m-2} \prec_c u_d \prec_c i_m$ holds in H . As the c-chain $i_1 \prec_c \dots \prec_c i_k \prec_c u_1 \prec_c \dots \prec_c u_d \prec_c i_m$ is proper, we have $u_d \neq i_{m-1}$. So $i_1 \prec_c \dots \prec_c i_m$ is not a convex chain in H , which is a contradiction.

□

The following result now extend Stembridge's characterization of Proposition 1.3 to CFC elements in terms of cylindric closures. This theorem is the main goal of this section, and will be useful for our enumerative purposes in the next sections.

Theorem 1.14. *A heap H is the heap of some word \mathbf{w} corresponding to a CFC element w if and only if the two following conditions are satisfied:*

- (i) *there is no cylindric convex c-chain $i_1 \prec_c \cdots \prec_c i_{m_{st}}$ in the cylindric closure H^c such that $s_{a_{i_1}} = s_{a_{i_3}} = \cdots = s$ and $s_{a_{i_2}} = s_{a_{i_4}} = \cdots = t$, where $3 \leq m_{st} < \infty$;*
- (ii) *there is no chain covering relation $i \prec_c j$ in the cylindric closure H^c such that $s_{a_i} = s_{a_j}$.*

Proof. Let \mathbf{w} be a word and let $H := H_{\mathbf{w}}$ be its heap. Assume that \mathbf{w} is a reduced word of a non CFC element. There exists by Definition 1.1 a cyclic shift of \mathbf{w} that is commutation equivalent to $\mathbf{w}' = w_1 s s w_2$ or $\mathbf{w}' = w_1 \underbrace{st \cdots st}_{m_{st}} w_2$.

Let H_1 be the heap of \mathbf{w}' . In the first case, by Proposition 1.3, H_1 contains a chain covering relation $i \prec_c j$ such that $s_{a_i} = s_{a_j} = s$, and in the second case, H_1 contains a convex chain $i_1 \prec_c \cdots \prec_c i_{m_{st}}$ such that $s_{a_{i_1}} = s_{a_{i_3}} = \cdots = s$ and $s_{a_{i_2}} = s_{a_{i_4}} = \cdots = t$, where $3 \leq m_{st} < \infty$. By Lemma 1.13, these two cases give respectively a chain covering relation and a cylindric convex c-chain in H_1^c . But \mathbf{w}' is commutation equivalent to a cyclic shift of \mathbf{w} , so there is an isomorphism between H^c and H_1^c by Proposition 1.9. This isomorphism preserves the cylindric convex c-chains, and this concludes the proof.

Conversely, if H^c contains the cylindric convex c-chain $i_1 \prec_c \cdots \prec_c i_{m_{st}}$, let \mathbf{w}' be the cyclic shift of \mathbf{w} beginning by $s_{a_{i_1}}$, and let H_1 be its heap. As all elements in the cylindric convex c-chain are distinct, H_1 contains the convex chain $i_1 \prec_c \cdots \prec_c i_{m_{st}}$. Therefore H_1 does not correspond to a FC element by Proposition 1.3 and H is not the heap of a CFC element. The same argument also holds if H^c contains a relation $i \prec_c j$ such that $s_{a_i} = s_{a_j}$, by letting this time \mathbf{w}' be the cyclic shift of \mathbf{w} beginning by s_{a_i} . □

For example, this theorem ensures that the heap H in Figure 2 does not correspond to a CFC element, as its cylindric closure H^c contains a chain covering relation $i \prec_c j$ such that $s_{a_i} = s_{a_j} = s_6$. The example in Figure 5 corresponds to a CFC element, according to Theorem 1.14.

Before ending this section, let us introduce a specific subset of CFC elements and recall the definition of alternating words which was defined in [1], and will be useful later.

Lemma 1.15. *Let W be a Coxeter group. The words in which each generator occurs at most once are reduced expressions of CFC elements of W .*

Proof. As each generator occurs at most once, we can not use any braid relation of length at least 3. □

This lemma justifies why this subset will be treated separately from other CFC elements in the rest of the article.

Definition 1.16. In a Coxeter group with linear Coxeter diagram Γ_n , a reduced word is called *alternating* if for $i = 0, 1, \dots, n-1$, the occurrences of s_i alternate

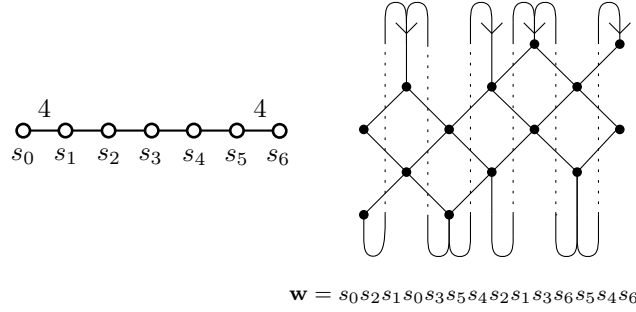

FIGURE 5. A reduced expression of a CFC element in \tilde{C}_6 , and the cylindrical closure of its heap.

with those of s_{i+1} . A heap is called *alternating* if it is the heap of an alternating word. If the Coxeter group is of type \tilde{A}_{n-1} (see Figure 6 for the Coxeter diagram), the diagram is not linear but we define the alternating word in the same way by setting $s_0 = s_n$.

2. CFC ELEMENTS IN TYPES \tilde{A} AND A

In this section, we will give a characterization and the enumeration of CFC elements in both types A_{n-1} and \tilde{A}_{n-1} . The corresponding Coxeter diagrams are given in Figure 6.

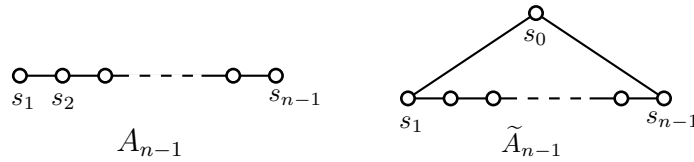

FIGURE 6. Coxeter diagrams of types A_{n-1} and \tilde{A}_{n-1} .

The elements of A_{n-1}^{CFC} were enumerated in [3] by using recurrence relations. Our characterization in terms of heaps allows us to take into account the Coxeter length. Actually, we can compute the generating functions $W^{CFC}(q) = \sum_{w \in W^{CFC}} q^{\ell(w)}$ for $W = A_{n-1}$ and $W = \tilde{A}_{n-1}$. In particular, when $q = 1$ and $W = A_{n-1}$, we get back the enumeration from [3] (recall that the number of CFC elements in type \tilde{A}_{n-1} is infinite). Our strategy is the following: first, we obtain a characterization of CFC elements in type \tilde{A}_{n-1} , we deduce from it a characterization of CFC elements in type A_{n-1} , then we derive the enumeration of CFC elements in type A_{n-1} and deduce from it the enumeration in type \tilde{A}_{n-1} .

2.1. **Characterization in type \tilde{A}_{n-1} .** Note that, in this type, the diagram of a cylindrical closure of a heap can be seen as drawn on a torus.

Theorem 2.1. *Let $n \geq 3$ be an integer. An element w of the Coxeter group of type \tilde{A}_{n-1} is CFC if and only if one (equivalently, any) of its reduced expressions w satisfies one of these conditions:*

- (a) each generator occurs at most once in \mathbf{w} , or
- (b) \mathbf{w} is an alternating word and $|\mathbf{w}_{s_0}| = |\mathbf{w}_{s_1}| = \dots = |\mathbf{w}_{s_{n-1}}| \geq 2$.

Proof. As said in Lemma 1.15, if each generator occurs at most once in \mathbf{w} , then w is a CFC element. So let \mathbf{w} be a reduced expression of a CFC element w having a generator occurring at least twice in \mathbf{w} . Recall that according to [1, Proposition 2.1], $w \in \tilde{A}_{n-1}$ is fully commutative if and only if \mathbf{w} is an alternating word. Let s_j be a generator that occurs at least twice in \mathbf{w} and such that for all $k \in \{0, 1, \dots, n-1\}$, $|\mathbf{w}_{s_j}| \geq |\mathbf{w}_{s_k}|$. We will prove that $|\mathbf{w}_{s_j}| = |\mathbf{w}_{s_{j+1}}|$ where we set $s_n = s_0$, which is sufficient to show that each generator occurs the same number of times. As \mathbf{w} is alternating, there are three possibilities:

- Case 1. $|\mathbf{w}_{s_j}| = |\mathbf{w}_{s_{j+1}}| - 1$. This contradicts the maximality of $|\mathbf{w}_{s_j}|$.
- Case 2. $|\mathbf{w}_{s_j}| = |\mathbf{w}_{s_{j+1}}| + 1$. By maximality of $|\mathbf{w}_{s_j}|$, there are two possibilities for $H_{\mathbf{w}}^c$: $|\mathbf{w}_{s_j}| = |\mathbf{w}_{s_{j-1}}|$ or $|\mathbf{w}_{s_j}| = |\mathbf{w}_{s_{j-1}}| + 1$. We obtain either a cylindric convex c-chain $x \prec_c y \prec_c z$ where x and z have label s_j and y has label s_{j-1} , or a chain covering relation between two indices p and q with label s_j . Therefore w is not a CFC element by Theorem 1.14 (see Figure 7, where we have circled the points x, y, z , and p, q , respectively).

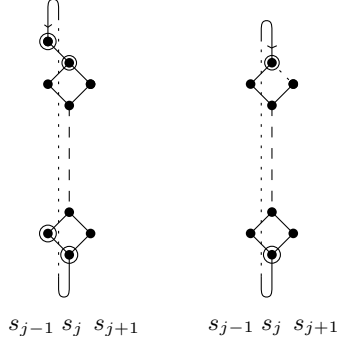

FIGURE 7. The two possible cylindric closures.

- Case 3. $|\mathbf{w}_{s_j}| = |\mathbf{w}_{s_{j+1}}|$ which is the expected condition.

Conversely, let \mathbf{w} be an alternating word such that $|\mathbf{w}_{s_0}| = |\mathbf{w}_{s_1}| = \dots = |\mathbf{w}_{s_{n-1}}| \geq 2$. The cylindric closure $H_{\mathbf{w}}^c$ can not contain a cylindric convex c-chain $x \prec_c y \prec_c z$ of length 3 such that $s_{a_x} = s_{a_z} = s_m$ and $s_{a_y} = s_{m+1}$ (respectively s_{m-1}): indeed, the required condition on \mathbf{w} implies that there exists an index ℓ such that $x \prec_c \ell \prec_c z$ with $s_{a_\ell} = s_{m-1}$ (respectively s_{m+1}), which is a contradiction with the cylindric convexity of the c-chain. The same argument holds for chain covering relations involving indices with the same labellings. \square

2.2. Characterization and enumeration in type A_{n-1} . In this case, we will both characterize the CFC elements and compute the generating function

$$A^{CFC}(x) := \sum_{n \geq 1} A_{n-1}^{CFC}(q)x^n.$$

We begin with a lemma which is a consequence of Corollary 5.6 in [3]. Nevertheless, we will give an alternative proof using Theorem 2.1.

Lemma 2.2. *Let $n \geq 3$ be an integer. The CFC elements in type A_{n-1} are those having reduced expressions in which each generator occurs at most once.*

Proof. Let \mathbf{w} be a reduced word of a CFC element in type A_{n-1} . By definition of the Coxeter diagram (see Figure 6), it is a reduced word of a CFC element in type \tilde{A}_{n-1} in which the generator s_0 does not occur. According to Theorem 2.1, the only such CFC elements in type \tilde{A}_{n-1} are those in which each generator occurs at most once. Conversely, if all generators occur at most once in \mathbf{w} , Lemma 1.15 ensures that \mathbf{w} is a reduced expression of a CFC element. \square

Theorem 2.3. *We have $A_0^{CFC}(q) = 1$, $A_1^{CFC}(q) = 1 + q$ and for $n \geq 2$,*

$$A_{n-1}^{CFC}(q) = (2q + 1)A_{n-2}^{CFC}(q) - qA_{n-3}^{CFC}(q). \quad (1)$$

Equivalently, we have the generating function:

$$A^{CFC}(x) = x \frac{1 - qx}{1 - (2q + 1)x + qx^2}.$$

Proof. According to [1, Proposition 2.7], FC elements of type A_{n-1} are in bijection with Motzkin type paths of length n , with starting and ending points at height 0, where the horizontal steps are labeled either L or R (and horizontal steps at height 0 are always labeled R). We recall the bijection, which is defined as follows: let w be a FC element in A_{n-1} , set \mathbf{w} one of its reduced expressions and set H its heap. To each $s_i \in S$, we associate a point $P_i = (i, |H_{s_i}|)$. As \mathbf{w} is alternating, three cases can occur:

- Case 1. $|H_{s_i}| = |H_{s_{i+1}}| - 1$, corresponding to an ascending step.
- Case 2. $|H_{s_i}| = |H_{s_{i+1}}| + 1$, corresponding to a descending step.
- Case 3. $|H_{s_i}| = |H_{s_{i+1}}|$, corresponding to an horizontal step, labelled by R if s_i occurs before s_{i+1} in \mathbf{w} , and by L otherwise.

According to Lemma 2.2, the restriction of this bijection to CFC elements is a bijection between CFC elements and the previous Motzkin paths, having length n , whose height does not exceed 1. By taking into account the first return to the x -axis (see Figure 8 for an example), we obtain the following recurrence relation for $n \geq 3$:

$$A_{n-1}^{CFC}(q) = A_{n-2}^{CFC}(q) + \sum_{m=2}^n 2^{m-2} q^{m-1} A_{n-1-m}^{CFC}(q), \quad (2)$$

where we write $A_{-1}^{CFC}(q) = 1$ (which fits with $A_0^{CFC}(q) = 1$, $A_1^{CFC}(q) = 1 + q$ and the expected recurrence relation).

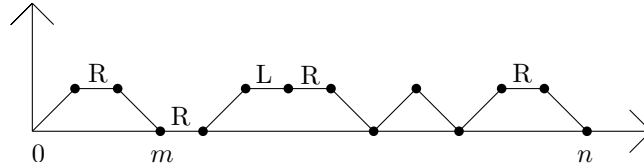

FIGURE 8. Motzkin path corresponding to the reduced expression $s_1 s_2 s_6 s_5 s_7 s_9 s_{11} s_{12}$ in type A_{12} .

Rewriting (2) with n replaced by $n - 1$ gives:

$$A_{n-2}^{CFC}(q) = A_{n-3}^{CFC}(q) + \sum_{m=2}^{n-1} 2^{m-2} q^{m-1} A_{n-2-m}^{CFC}(q). \quad (3)$$

Multiplying this by $2q$ and subtracting the result to (2) allows us to eliminate the sum over m , and leads to

$$A_{n-1}^{CFC}(q) - 2qA_{n-2}^{CFC}(q) = A_{n-2}^{CFC}(q) - qA_{n-3}^{CFC}(q), \quad (4)$$

which is equivalent to (1).

Classical techniques in generating function theory and the values $A_0^{CFC}(q) = 1$, $A_1^{CFC}(q) = 1 + q$ enable us to derive from (1) the desired generating function. \square

Notice that, as expected, if $q \rightarrow 1$, we find the odd-index Fibonacci numbers generating function of [3]. This q -analog was already known: the sequence A105306 in [12] counts permutations that avoid the patterns 321 and 3412, which are exactly permutations such that in a reduced expression, all the generators occur at most once.

2.3. Enumeration in type \tilde{A}_{n-1} . We enumerate here the CFC elements in type \tilde{A}_{n-1} according to their length. As for FC elements (see [1, 8]), the coefficients of the corresponding generating series are ultimately periodic.

Proposition 2.4. *We have for $n \geq 3$*

$$\tilde{A}_{n-1}^{CFC}(q) = P_{n-1}(q) + \frac{2^n - 2}{1 - q^n} q^{2n}, \quad (5)$$

where $P_{n-1}(q)$ is a polynomial of degree n satisfying for $n \geq 4$

$$P_n(q) = (3q + 1)P_{n-1}(q) - (2q + 2q^2)P_{n-2}(q) + q^2P_{n-3}(q), \quad (6)$$

with $P_1(q) = 1 + 2q + 2q^2$, $P_2(q) = 1 + 3q + 6q^2 + 6q^3$, and $P_3(q) = 1 + 4q + 10q^2 + 16q^3 + 14q^4$. Moreover, we can compute the generating function:

$$P(x) := \sum_{n=1}^{\infty} P_n(q)x^n = \frac{x(1 + 2q + 2q^2 - (2q + 2q^2)x + q^2x^2)}{(1 - qx)(1 - (2q + 1)x + qx^2)}.$$

Therefore the coefficients of $\tilde{A}_{n-1}^{CFC}(q)$ are ultimately periodic of exact period n , and the periodicity starts at length n .

Proof. In the same way as for the finite type A_{n-1} (see [1, Proposition 2.1]), FC elements of type \tilde{A}_{n-1} are in bijection with Motzkin type paths of length n satisfying the following conditions:

- (i) the starting point $P_0 = (0, |H_{s_0}|)$ and the ending point $P_n = (n, |H_{s_n}| = |H_{s_0}|)$ have the same height,
- (ii) horizontal steps at height 0 are always labeled R,
- (iii) if the path contains only horizontal steps at height ≥ 1 , the steps must have not all the same labelling.

The construction of the path corresponding to a FC element is the same as in type A if we set $s_n = s_0$. In Theorem 2.1, the alternating CFC elements in which all generators occur at least twice and in the same number correspond to Motzkin

type paths which have only horizontal steps. Therefore there are $2^n - 2$ such paths for all fixed starting height $h \geq 2$. This leads to the generating function

$$\sum_{h=2}^{+\infty} (2^n - 2)(q^n)^h,$$

which can be summed to obtain the second term on the right hand side of (5).

In Theorem 2.1, the CFC elements which correspond to reduced expressions with at most one occurrence of each generator correspond to Motzkin type paths which stay at height ≤ 1 , starting and ending at the same height. We denote by $P_{n-1}(q)$ the generating function of such elements. The computation of $P_1(q)$, $P_2(q)$ and $P_3(q)$ can be done by enumerating exhaustively these particular Motzkin paths. Let i (respectively j) be the first (respectively last) eventual return to the x -axis (see Figure 9 for an example).

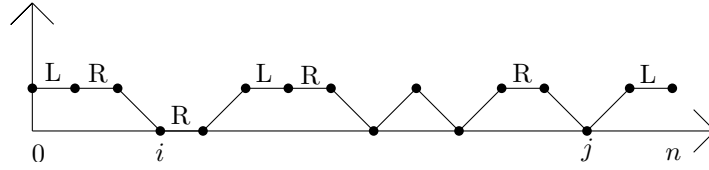

FIGURE 9. Motzkin path corresponding to the element $s_{14}s_1s_0s_2s_6s_5s_7s_9s_{11}s_{12}$ in type \tilde{A}_{14} .

We get

$$\begin{aligned} P_{n-1}(q) &= (2^n - 2)q^n + nq^{n-1}2^{n-2} \\ &+ \sum_{\substack{i=0 \\ i \neq 0 \text{ or} \\ j=i+1 \\ j \neq n-1}}^{n-2} \sum_{\substack{j=i+1 \\ j \neq n-1}}^{n-1} q^{n-1+i-j} 2^{n-2+i-j} A_{j-i-1}^{CFC}(q) + A_{n-2}^{CFC}(q), \end{aligned} \quad (7)$$

where the first term counts paths that stay at height 1, the second term counts paths such that $i = j$, and the last term counts paths such that $i = 0$ and $j = n - 1$. Rewriting (7) with $n - 1$ replaced by $n - 2$ gives

$$\begin{aligned} P_{n-2}(q) &= (2^{n-1} - 2)q^{n-1} + (n-1)q^{n-2}2^{n-3} \\ &+ \sum_{\substack{i=0 \\ i \neq 0 \text{ or} \\ j=i+1 \\ j \neq n-2}}^{n-3} \sum_{\substack{j=i+1 \\ j \neq n-2}}^{n-2} q^{n-2+i-j} 2^{n-3+i-j} A_{j-i-1}^{CFC}(q) + A_{n-3}^{CFC}(q). \end{aligned} \quad (8)$$

Multiplying (8) by $2q$ and subtracting the result to (7) allows us to simplify the double sum:

$$P_{n-1}(q) - 2qP_{n-2}(q) = 2q^n + 2^{n-2}q^{n-1} + A_{n-2}^{CFC}(q) + \sum_{i=2}^{n-2} 2^{i-1}q^i A_{n-2-i}^{CFC}(q). \quad (9)$$

The relation (2) in Theorem 2.3 allows us to rewrite the sum on the right hand side of (9) in the following way:

$$\sum_{i=2}^{n-2} 2^{i-1} q^i A_{n-2-i}^{CFC}(q) = 2q (A_{n-2}^{CFC}(q) - A_{n-3}^{CFC}(q) - 2^{n-3} q^{n-2}). \quad (10)$$

Combining (9) and (10) gives

$$P_{n-1}(q) - 2qP_{n-2}(q) = 2q^n + (2q+1)A_{n-2}^{CFC}(q) - 2qA_{n-3}^{CFC}(q), \quad (11)$$

which can be rewritten through (1) in the following way:

$$P_{n-1}(q) = 2qP_{n-2}(q) + 2q^n + A_{n-1}^{CFC}(q) - qA_{n-3}^{CFC}(q). \quad (12)$$

Next, we multiply (12) by x^{n-1} . We sum over $n \geq 5$ and use the generating function $A^{CFC}(x)$ obtained in Theorem 2.3 and the values of $P_1(q)$, $P_2(q)$, $P_3(q)$ to derive the expected generating function $P(x)$. As $P(x)$ is a rational fraction, the recurrence relation (6) for P_n comes directly from its denominator.

Next, we prove by induction on n that $P_{n-1}(q)$ is a polynomial in q of degree n with leading coefficient $(2^n - 2)$. This is true for $P_1(q)$, $P_2(q)$ and $P_3(q)$. If $P_{n-1}(q)$, $P_{n-2}(q)$, $P_{n-3}(q)$ satisfy the induction hypothesis, then by (6), $P_n(q)$ is a polynomial of degree n with leading coefficient $3(2^n - 2) - 2(2^{n-1} - 2) = 2^{n+1} - 2$.

Finally, we prove our claims about periodicity. The second term on the right hand side of (5) is periodic of exact period n : starting at length $n+1$, the sequence of coefficients is of the form:

$$\underbrace{(0, \dots, 0)}_{n-1}, 2^n - 2, 0, \dots, 0, 2^n - 2, 0, \dots$$

As $P_{n-1}(q)$ is a polynomial in q of degree n with leading coefficient $(2^n - 2)$, the periodicity of the coefficients of $\tilde{A}_{n-1}^{CFC}(q)$ starts at length at least n . Since $[q^{n-1}]P_{n-1}(q)$ is the number of CFC elements of length $n-1$, it is not zero, and the periodicity starts exactly at length n . \square

The situation in type \tilde{A}_{n-1} is very different from all other types that we study, as we will see later: this is the only case where the generating series $P_n(q)$ of CFC elements whose reduced expressions have at most one occurrence of each generator do not satisfy the recurrence relation $f_n(q) = (2q+1)f_{n-1}(q) - qf_{n-2}(q)$.

3. TYPES \tilde{C} , \tilde{B} , \tilde{D} , B AND D .

There are three other infinite families of affine Coxeter groups, they correspond to types \tilde{B} , \tilde{C} , \tilde{D} . All these groups contain an infinite number of CFC elements. In any of these cases, we can use Theorem 1.14 to derive a characterization of CFC elements and to compute the generating function $W^{CFC}(q) = \sum_{w \in W^{CFC}} q^{\ell(w)}$. We also show that this series is always ultimately periodic. The remaining classical finite types B and D are treated as consequences of the types \tilde{C} and \tilde{B} , respectively.

3.1. Types \tilde{C}_n and B_n . The Coxeter diagram of type \tilde{C}_n is represented below.

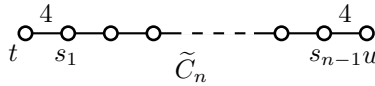

FIGURE 10. Coxeter diagram of type \tilde{C}_n .

According to [1, Theorem 3.4], the heaps of FC elements in type \tilde{C} are classified in five families, the alternating heaps, the zigzags, the left-peaks, the right-peaks and the left-right-peaks. As the definitions of the three last families are very close (and so the proofs involving these elements are similar), we only recall here the definition of left-peaks (and we refer to [1, Definition 3.1] for the others, examples being given in Figure 11 below).

Definition 3.1. Let H be a heap in type \tilde{C}_n . We say that H is a *left-peak* if there exists an integer $j \in \{1, \dots, n-1\}$ such that all the following conditions are satisfied:

- (i) The heap $H_{\{t, s_1, \dots, s_j\}}$ is the heap of the word $s_j s_{j-1} \dots s_1 t s_1 \dots s_{j-1} s_j$.
- (ii) If $j \neq n-1$, then there is no point labelled s_{j+1} between the two points labelled s_j and if $j = n-1$, then there is no point labelled u between the two points labelled s_{n-1} .
- (iii) The heap $H_{\{s_j, s_{j+1}, \dots, s_{n-1}, u\}}$ is alternating when we delete a point labelled s_j .

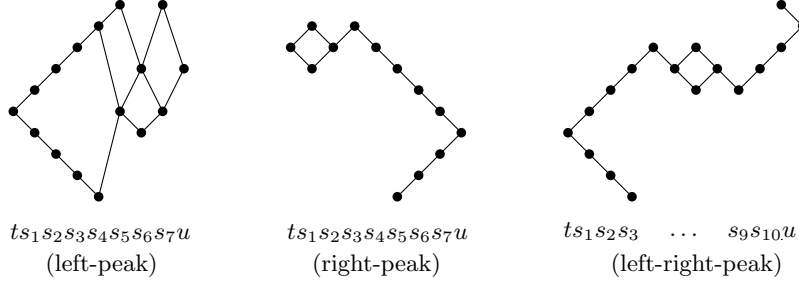

FIGURE 11. A left-peak, a right-peak and a left-right-peak. In the left-peak, we have $j = 3$.

Theorem 3.2. Let $n \geq 2$ be an integer. An element w of the Coxeter group of type \tilde{C}_n is CFC if and only if one (equivalently, any) of its reduced expressions \mathbf{w} satisfies one of the three following conditions:

- (a) each generator occurs at most once in \mathbf{w} , or
- (b) \mathbf{w} is an alternating word and $|\mathbf{w}_t| = |\mathbf{w}_{s_1}| = \dots = |\mathbf{w}_{s_{n-1}}| = |\mathbf{w}_u| \geq 2$, or
- (c) \mathbf{w} is a subword of the infinite periodic word $(ts_1s_2 \dots s_{n-1}us_{n-1} \dots s_2s_1)^\infty$, where $|\mathbf{w}_{s_1}| = \dots = |\mathbf{w}_{s_{n-1}}| \geq 2$ and $|\mathbf{w}_t| = |\mathbf{w}_u| = |\mathbf{w}_{s_1}|/2$ (that is we have $\mathbf{w} = s_i s_{i+1} \dots s_{i-2} s_{i-1}$ or $\mathbf{w} = s_i s_{i-1} \dots s_{i+2} s_{i+1}$, for a $i \in \{0, \dots, n\}$, where $s_0 = t$ and $s_n = u$).

Proof. Let w be a CFC element in the Coxeter group of type \tilde{C}_n and let \mathbf{w} be one of its reduced expressions. We denote by H the heap of \mathbf{w} and by H^c its cylindric closure. In [1, Theorem 3.4], heaps of FC elements are classified in five families, the first corresponding to alternating elements. As before, we distinguish two cases for elements in this first family:

Case 1. each generator occurs at most once in \mathbf{w} . According to Lemma 1.15, w is CFC as no long braid relations can be applied. These elements satisfy (a).

Case 2. \mathbf{w} is an alternating word in which a generator occurs at least twice. In this case, the proof will essentially be the same as for alternating words in type \tilde{A}_{n-1} . Recall that we write $t = s_0$ and $u = s_n$. Let $\{i_k, i_k + 1, \dots, i_\ell\}$ be a maximal interval such that $|\mathbf{w}_{s_{i_k}}| = \dots = |\mathbf{w}_{s_{i_\ell}}| \geq 2$ and $\forall j \in \{0, 1, \dots, n\}$, $|\mathbf{w}_{s_j}| \leq |\mathbf{w}_{s_{i_\ell}}|$. Assume $i_\ell \leq n - 1$. By maximality of $|\mathbf{w}_{s_{i_\ell}}|$ and the fact that \mathbf{w} is alternating, we have $|\mathbf{w}_{s_{i_\ell}}| = |\mathbf{w}_{s_{i_\ell+1}}| + 1$ and there are two possibilities in H^c : $|H_{s_{i_\ell}}^c| = |H_{s_{i_\ell-1}}^c|$ or $|H_{s_{i_\ell}}^c| = |H_{s_{i_\ell-1}}^c| + 1$. We obtain either a cylindric convex c-chain $v \prec_c x \prec_c y \prec_c z$ of length 4 where v, y both have label s_{i_ℓ} and x, z both have label $s_{i_\ell-1}$, or a chain covering relation between two indices p and q with label s_{i_ℓ} . This allows us to conclude that w is not CFC by Theorem 1.14 (see Figure 12 below; in each case, we have circled the points v, x, y, z and q, r respectively).

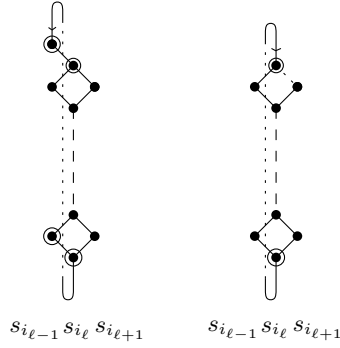

FIGURE 12. The two possible cylindric closures.

So, i_ℓ has to be equal to n for w to be CFC. The same argument for i_k will lead to $i_k = 0$, and so $|\mathbf{w}_{s_0}| = |\mathbf{w}_{s_1}| = \dots = |\mathbf{w}_{s_{n-1}}| \geq 2$. Such a word \mathbf{w} satisfies (b).

Next, we will show that among the four remaining families from [1], the CFC elements must satisfy (c).

First, we assume that H belongs to the family called zigzag in [1], that is \mathbf{w} is a subword of the infinite periodic word $(ts_1s_2 \dots s_{n-1}us_{n-1} \dots s_2s_1)^\infty$ with at least one generator that occurs more than three times (actually, this condition will not be used in this proof). Denote by s_i (respectively s_j) the first (respectively last) letter of \mathbf{w} . We assume that the second letter is s_{i-1} , and therefore $i \geq 1$ (the case where the second letter is s_{i+1} is symmetric and can be treated similarly).

If $s_j \notin \{s_{i-1}, s_{i+1}\}$, H^c necessarily contains either a cylindric convex c-chain of length 3 involving points in $H_{\{s_{i-1}, s_i\}}^c$ or a chain covering relation between two points with label s_i .

If $s_j = s_{i-1}$, then the last but one letter in \mathbf{w} is either s_i or s_{i-2} , so H^c takes one of the two forms I and II of Figure 13.

In case I, H^c contains a cylindric convex c-chain of length 4 involving points in $H_{\{s_{i-1}, s_i\}}^c$, given by the two first and the two last letters of \mathbf{w} (the corresponding points are circled in Figure 13, left). By Theorem 1.14, w is not CFC. In case II, H^c contains a cylindric convex c-chain of length 3 involving points in $H_{\{s_{i-1}, s_i\}}^c$, given

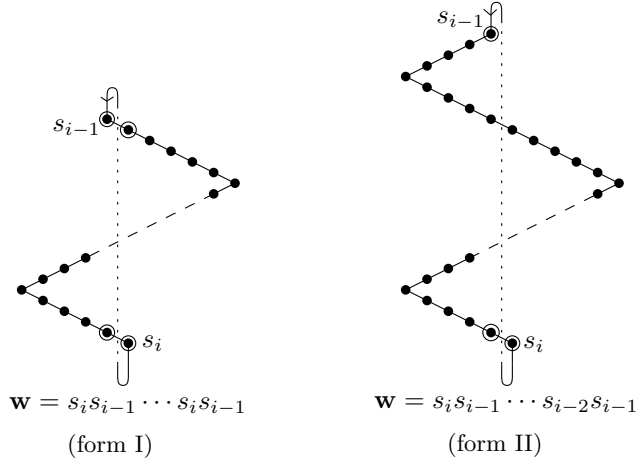

FIGURE 13. The two possible cylindric closures for $s_j = s_{i-1}$.

by the two first letters of \mathbf{w} and the last one (they are circled points in Figure 13, right). By Theorem 1.14, w is not CFC unless $s_i = u$, and therefore \mathbf{w} satisfies (c).

If $s_j = s_{i+1}$, then the last but one letter in \mathbf{w} is either s_i or s_{i+2} , so H^c takes one of the two forms III and IV of Figure 14.

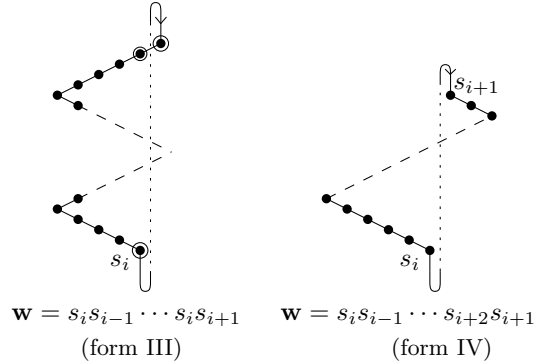

FIGURE 14. The two possible cylindric closures for $s_j = s_{i+1}$.

In case III, H^c contains a cylindric convex c -chain of length 3 involving points in $H^c_{\{s_i, s_{i+1}\}}$, given by the first and the two last letters of \mathbf{w} (the corresponding points are circled in Figure 14, left). By Theorem 1.14, w is not CFC unless $s_i = s_0 = t$ or $s_{i+1} = s_n = u$. The first possibility is not satisfied as $i \geq 1$. For the second possibility, \mathbf{w} satisfies (c). In case IV, \mathbf{w} satisfies (c).

Finally, we assume that H belongs to one of the three remaining families, that is the left-peaks, right-peaks and left-right-peaks defined in [1, Definition 3.1]. First, if H is a left-peak, there exists a unique integer $j \in \{1, \dots, n-1\}$ satisfying the conditions of Definition 3.1. Three cases can occur for $|\mathbf{w}_{s_{j+1}}|$.

- Case 1. If $|\mathbf{w}_{s_{j+1}}| = 0$, then H^c contains a relation $k \prec_c \ell$ such that k and ℓ have label s_j (as illustrated in form V of Figure 15 below). Therefore w is not CFC.
- Case 2. If $|\mathbf{w}_{s_{j+1}}| = 1$, then H^c contains a cylindric convex c-chain of length 3 involving the points with labels s_j and s_{j+1} (see form VI of Figure 15 below, where involved points are circled). Consequently, w is not CFC unless $j = n - 1$. But if $j = n - 1$, then the condition (c) is satisfied, and \mathbf{w} is of the form $us_{n-1}s_{n-2} \dots s_1ts_1 \dots s_{n-1}$ or $s_{n-1}s_{n-2} \dots s_1ts_1 \dots s_{n-1}u$ (this is illustrated in Figure 15, form VII).
- Case 3. If $|\mathbf{w}_{s_{j+1}}| = 2$, then, as the word remaining after the deletion of the occurrences of t, s_1, \dots, s_{j-1} and one occurrence of s_j in \mathbf{w} is alternating, the same reasoning as for alternating words allows us to prove that all the generators $s_{j+2}, s_{j+3}, \dots, s_{n-1}, u$ occur twice in \mathbf{w} . Both occurrences of s_{j+1} and the last occurrence of s_{j+2} form a convex c-chain of length 3 (see form VIII in Figure 15 below, where involved points are circled), which prevents w from being CFC, unless $j + 1 = n - 1$. But if $j + 1 = n - 1$, then the two occurrences of s_{n-1} and the two occurrences of u form a convex c-chain of length 4 starting at the first occurrence of u . Therefore w is not CFC.

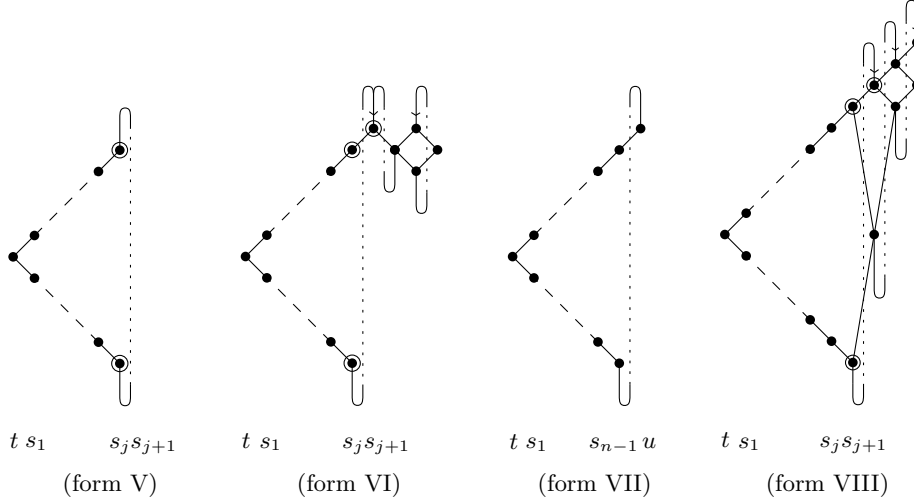

FIGURE 15. The different left-peak cylindric closures.

If H is a right-peak, the same reasoning as for left-peaks applies to show that w is not CFC unless \mathbf{w} has one of the two following forms: $ts_1s_2 \dots s_{n-1}us_{n-1} \dots s_1$ or $s_1s_2 \dots s_{n-1}us_{n-1} \dots s_1t$, and so satisfies (c).

If H is a left-right-peak, let $j, k \in \{1, \dots, n - 1\}$ be the two corresponding unique integers in [1, Definition 3.1]. Two cases can occur for j and k . If $j \neq k - 1$, the same discussion as in the case of left-peaks about $|\mathbf{w}_{s_{j+1}}|$ allows us to prove that w is not CFC (as the case $j = n - 1$ is impossible). If $j = k - 1$, then \mathbf{w} satisfies (c), and takes one of the two following forms: $s_js_{j-1} \dots t \dots s_js_k \dots u \dots s_k$ or $s_k s_{k+1} \dots u \dots s_k s_j \dots t \dots s_j$.

Conversely, any \mathbf{w} satisfying one of the three conditions (a), (b), or (c) is a reduced expression for a CFC element. Indeed, the corresponding cylindric closure H^c can not contain a relation $i \prec_c j$ such that i and j have the same label. Moreover, H^c contains a cylindric convex c-chain of length 3 only if the involved points belong to $H_{\{t, s_1\}}^c$ or $H_{\{s_{n-1}, u\}}^c$. Finally, H^c does not contain any cylindric convex c-chain of length 4: this comes from the definition of (a) and (c), and for \mathbf{w} satisfying (b), the same proof as in type \tilde{A} holds (see the end of the proof of Theorem 2.1). \square

Corollary 3.3. *For $n \geq 2$, we have the generating function:*

$$\tilde{C}_n^{CFC}(q) = A_{n+1}^{CFC}(q) + \frac{2^n}{1 - q^{n+1}} q^{2(n+1)} + \frac{2n}{1 - q^{2n}} q^{2n}. \quad (13)$$

The coefficients of $\tilde{C}_n^{CFC}(q)$ are ultimately periodic of exact period $n(n+1)$ if n is odd, and $2n(n+1)$ if n is even. Moreover, periodicity starts at length $n+1$.

Proof. Notice that the sets of elements whose reduced expressions satisfy condition (a), (b) or (c) of Theorem 3.2 are disjoint. The first term in (13) corresponds to CFC elements satisfying (a). Indeed, they are in bijection with A_{n+1}^{CFC} according to the Coxeter diagrams of types A_{n+1} and \tilde{C}_n .

Now we show that the second term in (13) corresponds to CFC elements whose reduced expressions satisfy (b). If we fix an integer $h \geq 2$, there are 2^n such elements with $h = |\mathbf{w}_t| = |\mathbf{w}_{s_1}| = \dots = |\mathbf{w}_{s_{n-1}}| = |\mathbf{w}_u|$. Indeed, for each generator t, s_1, \dots, s_{n-1} in \mathbf{w} , there are two possibilities: s_i appears before or after s_{i+1} for $i = 0, 1, \dots, n-1$, where $s_0 = t$ and $s_n = u$. The generating function of elements satisfying (b) is then equal to

$$\sum_{h \geq 2} 2^n q^{h(n+1)} = \frac{2^n}{1 - q^{n+1}} q^{2(n+1)}.$$

With the condition on the number of occurrences of each generator, we can see that the length of an element whose reduced expressions satisfy (c) must be a multiple of $2n$, and there are $2n$ such elements for each possible length (the first two letters in \mathbf{w} can be $s_i s_{i+1}$ or $s_i s_{i-1}$ for all $i \in \{1, \dots, n-1\}$ or ts_1 or us_{n-1}). This gives the term

$$\sum_{h \geq 1} 2nq^{2nh} = \frac{2n}{1 - q^{2n}} q^{2n},$$

and establishes (13).

Now, we prove the periodicity. The coefficients of

$$\frac{2^n}{1 - q^{n+1}} q^{2(n+1)} + \frac{2n}{1 - q^{2n}} q^{2n}$$

are ultimately periodic; starting at length $n+2$, the sequence of coefficients is of the form:

$$(0, \dots, 0, \underbrace{2n, 0, 2^n, 0, \dots}_{n-2}).$$

The period is the least common multiple of $n+1$ and $2n$, which is $n(n+1)$ if n is odd, and $2n(n+1)$ if n is even. In the same way as in the proof of Proposition 2.4, we can use (1) to do an induction on n to prove that $A_{n+1}^{CFC}(q)$ is a polynomial in q of degree $n+1$ with leading coefficient 2^n . According to this and (13), periodicity

starts at length at least $n + 1$. As $[q^n]A_{n+1}^{CFC}(q)$ is the number of CFC elements of length n in type A_{n+1} , it is non-zero according to Lemma 2.2. So the periodicity starts exactly at length $n + 1$. \square

We can deduce the characterization in type B_n , whose corresponding Coxeter diagram is recalled below.

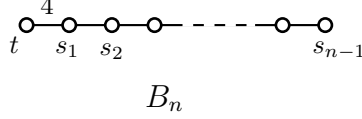

FIGURE 16. Coxeter diagram of type B_n .

Corollary 3.4. *Let $n \geq 3$ be an integer. The CFC elements in type B_n are those having reduced expressions in which each generator occurs at most once. Moreover,*

$$B_n^{CFC}(q) = A_n^{CFC}(q).$$

Proof. Let w be a CFC element in type B_n , and let \mathbf{w} be one of its reduced expressions. By comparing the Coxeter diagrams, w is a CFC element of type \tilde{C}_n such that the generator u does not occur in \mathbf{w} . But, according to Theorem 2.1, the only such CFC elements are those for which \mathbf{w} satisfies (a) (and has no u): indeed, if \mathbf{w} satisfies (b) (respectively (c)), all generators appear the same number of times (respectively u must appear in \mathbf{w}). Conversely, if all generators occur at most once in \mathbf{w} , we already saw in lemma 1.15 that w is a CFC element. \square

3.2. Types \tilde{B}_{n+1} and D_{n+1} . We will first obtain a characterization of CFC elements in type \tilde{B}_{n+1} , we deduce a characterization and the enumeration in type D_{n+1} , and we finally deduce the enumeration in type \tilde{B}_{n+1} .

In what follows, by “ \mathbf{w} is an alternating word”, we mean that if we replace t_1 and t_2 by s_0 , and u by s_n , \mathbf{w} is an alternating word in the sense of Definition 1.16, and t_1 and t_2 alternate in \mathbf{w} .

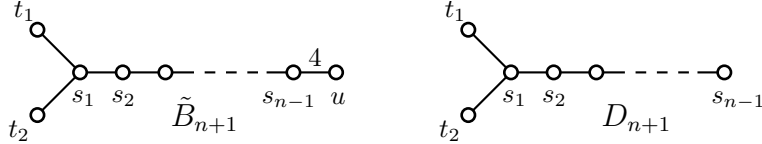

FIGURE 17. Coxeter diagrams of types \tilde{B}_{n+1} and D_{n+1} .

Theorem 3.5. *Let $n \geq 3$ be an integer. An element w of the Coxeter group of type \tilde{B}_{n+1} is CFC if and only if one (equivalently, any) of its reduced expressions \mathbf{w} satisfies one of these conditions:*

- (a) *each generator occurs at most once in \mathbf{w} , or*
- (b) *\mathbf{w} is an alternating word, $|\mathbf{w}_{s_1}| = \dots = |\mathbf{w}_{s_{n-1}}| = |\mathbf{w}_u| \geq 2$, and $|\mathbf{w}_{t_1}| = |\mathbf{w}_{t_2}| = |\mathbf{w}_{s_1}|/2$ (in particular, $|\mathbf{w}_{s_1}|$ is even), or*

- (c) \mathbf{w} is a subword of $(t_1 t_2 s_1 s_2 \dots s_{n-1} u s_{n-1} \dots s_2 s_1)^\infty$, which is an infinite periodic word, where t_1 and t_2 are allowed to commute, such that $|\mathbf{w}_{s_1}| = \dots = |\mathbf{w}_{s_{n-1}}| \geq 2$, and $|\mathbf{w}_{t_2}| = |\mathbf{w}_{t_1}| = |\mathbf{w}_u| = |\mathbf{w}_{s_1}|/2$ (that is \mathbf{w} takes one of the five forms: $s_i s_{i+1} \dots s_{i-2} s_{i-1}$ or $s_i s_{i-1} \dots s_{i+2} s_{i+1}$ or $t_1 s_1 \dots s_1 t_2$ or $t_2 s_1 \dots t_1$ or $t_1 t_2 s_1 \dots s_1$ for a $i \in \{1, \dots, n-1\}$).

Proof. The steps of this proof are the same as for Theorem 3.2. Let w be a CFC element in type \tilde{B}_{n+1} and let \mathbf{w} be one of its reduced expressions. We denote by H the heap of \mathbf{w} and by H^c its cylindric closure. In [1, Theorem 3.10], FC elements are classified in five families. The first corresponds to alternating elements. As before, we distinguish two cases:

- Case 1. each generator occurs at most once in \mathbf{w} . These elements satisfy (a).
 Case 2. \mathbf{w} comes from an alternating word of type \tilde{C}_n , where we applied the replacements $(t, t, \dots, t) \rightarrow (t_1, t_2, t_1, \dots)$ or (t_2, t_1, \dots) . The same proof as for type \tilde{C} gives $|\mathbf{w}_t| = |\mathbf{w}_{s_1}| = \dots = |\mathbf{w}_{s_{n-1}}| = |\mathbf{w}_u|$ (here, t is either t_1 or t_2). If $|\mathbf{w}_t|$ is odd, assume that we applied the replacement $(t, t, \dots, t) \rightarrow (t_1, t_2, t_1, \dots)$ (the other case is symmetric). We can distinguish four cases: t_1 occurs before or after s_1 in \mathbf{w} and s_1 occurs before or after s_2 in \mathbf{w} . In all these cases, we find a cylindric convex c-chain of length 3 involving three of the four following points: the first and the last occurrence of t_1 , and the first and the last occurrence of s_1 . (For example, if t_1 occurs before s_1 and s_1 occurs before s_2 , the first and the last occurrence of s_1 and the first occurrence of t_1 form a cylindric convex c-chain.) So $|\mathbf{w}_t|$ is even, and as \mathbf{w} is alternating, $|\mathbf{w}_{t_2}| = |\mathbf{w}_{t_1}| = |\mathbf{w}_{s_1}|/2$. Such a word \mathbf{w} satisfies (b).

Next, we will show that among the four remaining families from [1], the CFC elements must satisfy (c). There are two possibilities:

- Case 1. \mathbf{w} is a subword of $(t_1 t_2 s_1 s_2 \dots s_{n-1} u s_{n-1} \dots s_2 s_1)^\infty$, which is an infinite periodic word, where t_1 and t_2 are allowed to commute, such that a generator occurs more than twice. The same cases distinction as in type \tilde{C} yields the required condition (c).
 Case 2. $H_{\mathbf{w}}$ is a heap among special cases analogous to the ones in type \tilde{C}_n which are non CFC, except for those which satisfy (c) (and are of length $2(n+2)$). We omit the details here, as the proof is very similar to type \tilde{C}_n .

Conversely, all elements w whose reduced expressions \mathbf{w} satisfy one of the three conditions (a), (b) or (c) are CFC. Indeed, $H_{\mathbf{w}}^c$ does not contain relations $i \prec j$ such that i and j have the same label. The cylindric closure $H_{\mathbf{w}}^c$ contains cylindric convex c-chains of length 3 only if the involved points have labels s_{n-1} or u and $H_{\mathbf{w}}^c$ does not contain cylindric convex c-chain of length 4 (the same proof as for Theorem 3.2 applies). \square

Proposition 3.6. *Let $n \geq 3$ be an integer. The CFC elements in type D_{n+1} are those having reduced expressions in which each generator occurs at most once. Moreover, we have $D_1^{CFC}(q) = 1 + q$, $D_2^{CFC}(q) = 1 + 2q + q^2$, $D_3^{CFC}(q) = 1 + 3q + 5q^2 + 4q^3$ and for $n \geq 3$:*

$$D_{n+1}^{CFC}(q) = (2q + 1)D_n^{CFC}(q) - qD_{n-1}^{CFC}(q). \quad (14)$$

In other words, we have

$$D^{CFC}(x) := \sum_{n=0}^{\infty} D_{n+1}^{CFC}(q)x^n = \frac{(1+q) - xq(1+q) + x^2q^2(1+2q)}{1 - (2q+1)x + qx^2}.$$

Proof. Let w be a CFC element of type D_{n+1} and let \mathbf{w} be one of its reduced expressions. By checking the Coxeter diagrams, w is a CFC element of type \tilde{B}_{n+1} such that the generator u does not occur in \mathbf{w} . But, according to Theorem 3.5, the only such CFC elements are those having reduced expressions satisfying condition (a) (and having no u): indeed, if \mathbf{w} satisfies (b) or (c), u must appear in \mathbf{w} . Conversely, if all generators occur at most once in \mathbf{w} , we already saw that w is CFC.

Using this characterization of CFC elements of type D_{n+1} allows us to compute the polynomials $D_1^{CFC}(q)$, $D_2^{CFC}(q)$ and $D_3^{CFC}(q)$ by an exhaustive enumeration.

If $n \geq 3$, any CFC element of type D_{n+1} can be uniquely obtained from a CFC element w' in A_{n-1} by adding to a reduced expression \mathbf{w}' of w' either nothing, or one occurrence of t_1 (with two choices: before or after s_1), or one occurrence of t_2 (with two choices), or one occurrence of t_1 and t_2 (with four choices). However, if s_1 does not occur in \mathbf{w}' , we have no choice for adding t_1 or/and t_2 , as t_1 and t_2 commute with all other generators. This leads to the following recurrence relation:

$$D_{n+1}^{CFC}(q) = (1 + 4q + 4q^2)A_{n-1}^{CFC}(q) - (2q + 3q^2)A_{n-2}^{CFC}(q).$$

Next, we multiply this relation by x^{n-1} and we sum over $n \geq 3$. We compute the generating function $D^{CFC}(x)$ by using $D_1^{CFC}(q)$, $D_2^{CFC}(q)$, $D_3^{CFC}(q)$ and the generating function $A^{CFC}(x)$ in Theorem 2.3. As $D^{CFC}(x)$ is a rational fraction, the recurrence relation (14) is extracted directly from the denominator of $D^{CFC}(x)$. \square

Corollary 3.7. *We have for $n \geq 3$:*

$$\tilde{B}_{n+1}^{CFC}(q) = D_{n+2}^{CFC}(q) + \frac{2^{n+1}}{1 - q^{2(n+1)}} q^{2(n+1)} + \frac{2(n+1)}{1 - q^{2n+1}} q^{2n+1}. \quad (15)$$

Furthermore, the coefficients of $\tilde{B}_{n+1}^{CFC}(q)$ are ultimately periodic of exact period $2(n+1)(2n+1)$ and the periodicity starts at length $n+3$.

Proof. Notice that the sets of elements whose reduced expressions satisfy condition (a), (b) or (c) of Theorem 3.5 are disjoint. The first term in (15) corresponds to the set of CFC elements whose reduced words satisfy (a). By Proposition 3.6, this set is in bijection with D_{n+2}^{CFC} .

The second term in (15) corresponds to CFC elements whose reduced expressions satisfy (b): these have length a multiple of $2(n+1)$, and there are 2^{n+1} of them for each possible length.

With the condition on the number of occurrences of each generator, we can see that the length of elements satisfying (c) must be a multiple of $2n+1$, and there are $2n+2$ such elements for each possible length (the first two letters can be $s_i s_{i+1}$, $s_i s_{i-1}$, $u s_{n-1}$, $t_1 t_2$, $t_1 s_1$ or $t_2 s_1$). This establishes (15).

Now, we prove the periodicity. The coefficients of

$$\frac{2^{n+1}}{1 - q^{2(n+1)}} q^{2(n+1)} + \frac{2(n+1)}{1 - q^{2n+1}} q^{2n+1}$$

are ultimately periodic; starting at length $n + 3$, the sequence of coefficients is of the form:

$$\underbrace{(0, \dots, 0)}_{n-2}, 2(n+1), 2^{n+1}, 0, \dots.$$

The period is the least common multiple of $2(n+1)$ and $2n+1$, which is $2(n+1)(2n+1)$. Using (14), an induction on n allows us to prove that $D_{n+2}^{CFC}(q)$ is a polynomial in q with degree $n+2$ and leading coefficient 2^{n+1} . So, the beginning of the periodicity is exactly $n+3$. \square

3.3. Type \tilde{D}_{n+2} . The situation is very similar to the previous one in type \tilde{D}_{n+2} for the characterization, but the generating function takes a slightly different form, due to the specificity of the Coxeter diagram.

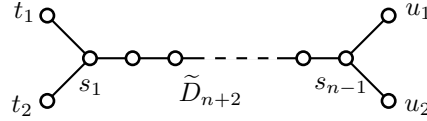

FIGURE 18. Coxeter diagram of type \tilde{D}_{n+2} .

In what follows, by “ \mathbf{w} is an alternating word”, we mean that if we replace t_1 and t_2 by s_0 , and u_1 and u_2 by s_n , the image of \mathbf{w} is an alternating word in the sense of Definition 1.16, t_1 and t_2 alternate in \mathbf{w} , and u_1 and u_2 alternate in \mathbf{w} .

Theorem 3.8. *Let $n \geq 2$ be an integer. An element w of the Coxeter group of type \tilde{D}_{n+2} is CFC if and only if one (equivalently, any) of its reduced expressions \mathbf{w} satisfies one of these conditions:*

- (a) *each generator occurs at most once in \mathbf{w} , or*
- (b) *\mathbf{w} is an alternating word, $|\mathbf{w}_{s_1}| = \dots = |\mathbf{w}_{s_{n-1}}| \geq 2$, and $|\mathbf{w}_{t_1}| = |\mathbf{w}_{t_2}| = |\mathbf{w}_{u_1}| = |\mathbf{w}_{u_2}| = |\mathbf{w}_{s_1}|/2$ (in particular, $|\mathbf{w}_{s_1}|$ is even), or*
- (c) *\mathbf{w} is a subword of $(t_1 t_2 s_1 s_2 \dots s_{n-1} u_1 u_2 s_{n-1} \dots s_2 s_1)^\infty$, which is an infinite periodic word, where t_1 and t_2 , u_1 and u_2 are allowed to commute, such that $|\mathbf{w}_{s_1}| = \dots = |\mathbf{w}_{s_{n-1}}| \geq 2$, and $|\mathbf{w}_{t_2}| = |\mathbf{w}_{t_1}| = |\mathbf{w}_{u_1}| = |\mathbf{w}_{u_2}| = |\mathbf{w}_{s_1}|/2$.*

Proof. The same proof as for Theorem 3.5 holds, one only needs to add the replacements $(u, u, \dots, u) \rightarrow (u_1, u_2, \dots)$ or (u_2, u_1, \dots) and to use [1]. Therefore we omit the details. \square

Again, we can compute the corresponding generating function.

Proposition 3.9. *We have for $n \geq 2$:*

$$\tilde{D}_{n+2}^{CFC}(q) = Q_{n+2}(q) + \frac{2^{n+2} + 2(n+2)}{1 - q^{2(n+1)}} q^{2(n+1)}, \quad (16)$$

where $Q_{n+2}(q)$ is a polynomial in q of degree $n+3$ such that $Q_4(q) = 1 + 5q + 14q^2 + 28q^3 + 33q^4 + 16q^5$, $Q_5(q) = 1 + 6q + 20q^2 + 46q^3 + 73q^4 + 72q^5 + 32q^6$, and for $n \geq 4$:

$$Q_{n+2}(q) = (2q+1)Q_{n+1}(q) - qQ_n(q). \quad (17)$$

Moreover, the coefficients of $\tilde{D}_{n+2}^{CFC}(q)$ are ultimately periodic of exact period $2(n+1)$, and the periodicity starts at length $n+4$.

Proof. Notice that the sets of elements whose reduced expressions satisfy condition (a), (b) or (c) of Theorem 3.8 are disjoint. The first term in (16) corresponds to the set of CFC elements whose reduced expressions satisfy (a). Any such element can be uniquely obtained from a CFC element w of type D_{n+1} having \mathbf{w} as a reduced expression by adding either nothing to \mathbf{w} , or one occurrence of u_1 (with two choices: before or after s_{n-1}), or one occurrence of u_2 (with two choices), or one occurrence of u_1 and u_2 (with four choices). However, if s_{n-1} does not occur in \mathbf{w} , we have no choice for adding u_1 or/and u_2 , as u_1 and u_2 commute with all other generators. This leads to the following recurrence relation:

$$Q_{n+2}(q) = (1 + 4q + 4q^2)D_{n+1}^{CFC}(q) - (2q + 3q^2)D_n^{CFC}(q).$$

Using this, the expected recurrence relation (17) for the polynomials $Q_n(q)$ is equivalent to the following recurrence relation involving the polynomials $D_n^{CFC}(q)$:

$$\begin{aligned} & (1 + 4q + 4q^2)D_{n+1}^{CFC}(q) - (2q + 3q^2)D_n^{CFC}(q) \\ &= (2q + 1) \left[(1 + 4q + 4q^2)D_n^{CFC}(q) - (2q + 3q^2)D_{n-1}^{CFC}(q) \right] \\ & \quad - q \left[(1 + 4q + 4q^2)D_{n-1}^{CFC}(q) - (2q + 3q^2)D_{n-2}^{CFC}(q) \right]. \end{aligned}$$

This is true by gathering on one side the terms with common factor $(1 + 4q + 4q^2)$ and on the other side the terms with common factor $(2q + 3q^2)$, and noticing that both sides vanish thanks to (14).

Elements satisfying (b) have length a multiple of $2(n + 1)$ and there are 2^{n+2} of them. Elements satisfying (c) have also length a multiple of $2(n + 1)$, and there are $2(n + 2)$ of them (by inspecting the first two letters). This establishes (16).

The second term on the right hand side of (16) is periodic of exact period $2(n+1)$: starting at length $n + 4$, the sequence of coefficients is of the form:

$$\underbrace{(0, \dots, 0)}_{n-2}, 2^{n+2} + 2(n + 2), 0, \dots, 0, 2^{n+2} + 2(n + 2), \dots.$$

An induction on n using (17) allows us to show that $Q_{n+2}(q)$ is a polynomial in q of degree $n + 3$ with leading coefficient 2^{n+2} . According to this property and (16), the periodicity starts at length $n + 4$. \square

Note that the generating function $Q(x)$ of the polynomials $Q_n(q)$ is computable through classical techniques. However it does not have a nice expression.

3.4. Exceptional types. Exceptional finite types are E_6 , E_7 , E_8 , F_4 , H_2 , H_3 , H_4 , G_2 , and $I_2(m)$. Enumerating CFC elements according to the length in these two last types is trivial, while other groups are special cases of the families E_n ($n \geq 6$), F_n ($n \geq 4$), H_n ($n \geq 3$). It is shown in [3] that these families contain a finite number of CFC elements. It is possible to apply our method to characterize them in terms of cylindric closure of heaps and obtain recurrence relations for their generating functions according to the length. However, as the parameter q can be inserted directly in the recurrences of [3], we leave this to the interested reader.

For exceptional affine types having a finite number of CFC elements (\tilde{E}_8 and \tilde{F}_4), generating functions of CFC elements are polynomials recursively computable as in type A , because $\tilde{E}_8 = E_9$ and $\tilde{F}_4 = F_5$.

It remains to study three exceptional affine types having an infinite number of CFC elements. Their Coxeter diagrams are represented below. For these types, we only give the result without detailing the proof, but only sketching it: as for other

affine types, we look at the classification of FC elements in [1, Lemmas 5.2–5.4], and see that there exists CFC elements only for some explicit length, which must be either bounded or an integer multiple of a constant depending on the considered type.

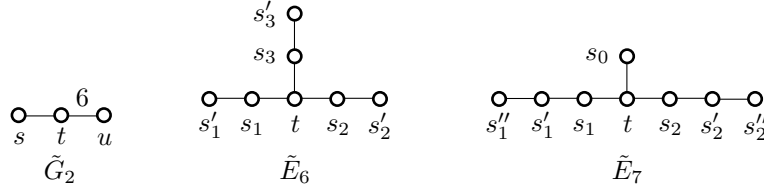

FIGURE 19. Coxeter diagrams of types \tilde{G}_2 , \tilde{E}_6 and \tilde{E}_7 .

Theorem 3.10. *Let W be a Coxeter group of exceptional affine type \tilde{G}_2 (respectively \tilde{E}_6 , respectively \tilde{E}_7).*

We define in W the element w_2 as the one which admits $utsut$ (respectively $s_1ts'_1s_1s_2ts'_2s_2s_3ts'_3s_3$, respectively $s_1ts'_1s_0s_1s'_1ts'_1s_1s_2ts'_2s_0s_2s'_2ts'_2s_2$) as a reduced expression. An element $w \in W$ is CFC if and only if one (equivalently, any) of its reduced expressions \mathbf{w} satisfies one of these conditions:

- (i) \mathbf{w} belongs to a finite set depending on W , or
- (ii) $\mathbf{w} = \mathbf{w}_1\mathbf{w}_2^n\mathbf{w}_3$, where n is a non-negative integer, $\mathbf{w}_2 \in R(w_2)$ and $\mathbf{w}_3\mathbf{w}_1 = \mathbf{w}_2$.

Consequently, the following generating functions hold:

$$\tilde{G}_2^{CFC}(q) = R_1(q) + \frac{6q^5}{1 - q^5},$$

$$\tilde{E}_6^{CFC}(q) = R_2(q) + \frac{23q^{12}}{1 - q^{12}},$$

$$\tilde{E}_7^{CFC}(q) = R_3(q) + \frac{45q^{18}}{1 - q^{18}},$$

where $R_1(q)$, $R_2(q)$ and $R_3(q)$ are polynomials.

3.5. Logarithmic CFC elements. Here we study some particular elements of a general Coxeter group W . Recall that for $w \in W^{CFC}$, the *support* $\text{supp}(w)$ of w is the set of generators that appear in a (equivalently, any) reduced expression of w . It is well known that if $w \in W$ and k is a positive integer, then $\ell(w^k) \leq k\ell(w)$. If equality holds for all $k \in \mathbb{N}^*$ (that is \mathbf{w}^k is reduced for all k , where \mathbf{w} is a reduced expression of w), then w is *logarithmic* (see [3] for more information about logarithmic elements). For example, there is no logarithmic element in finite Coxeter groups, because there is a finite number of reduced expressions. By using our characterizations for affine types in Theorems 2.1, 3.5, 3.2, 3.8, we derive the following consequence. A generalization of this result was proved for all Coxeter groups in [10, Corollary E], by using geometric group theoretic methods. Nevertheless, as our approach is different and more combinatorial, we find interesting to give our proof, although it only works for affine types.

Theorem 3.11. *For W a Coxeter group of type $\tilde{A}, \tilde{B}, \tilde{C}$, or \tilde{D} , if $w \in W$ is a CFC element, w is logarithmic if and only if a (equivalently, any) reduced expression \mathbf{w} of w has full support (that is all generators occur in \mathbf{w}). In particular, there is a finite number of CFC elements which are not logarithmic.*

Proof. Let $w \in W^{CFC}$ and let \mathbf{w} be one of its reduced expressions. Assume that \mathbf{w} has not full support. In this case, w belongs to a proper parabolic subgroup of W , which is a finite Coxeter group by a classical property of affine Coxeter groups (see [9, Section 5.5]). So w is not logarithmic, and there is a finite number of such elements, which correspond to elements satisfying (a) in Theorems 2.1, 3.5, 3.2, 3.8 and such that at least one generator does not occur in \mathbf{w} .

Conversely, assume that w is a CFC element with full support. According to Theorems 2.1, 3.5, 3.2, 3.8, \mathbf{w} must satisfy (b) or (c) or has to be a Coxeter element (which means that each generator occurs exactly once in \mathbf{w}). If w is a Coxeter element, w is logarithmic (see [16]). If \mathbf{w} satisfies (b) (respectively (c)), we check that \mathbf{w}^k also satisfies (b) (respectively (c)) and is therefore reduced. It follows that w is logarithmic. \square

We can also notice that the powers of Coxeter elements are always CFC in affine types \tilde{A}_{n-1} and \tilde{C}_n because they satisfy the alternating word condition, but are never CFC elements in types \tilde{B}_{n+1} and \tilde{D}_{n+2} (because they satisfy neither the alternating word condition nor condition (c)).

4. CFC INVOLUTIONS

A natural question that arises in the study of FC elements is to compute the number of FC involutions in finite and affine Coxeter groups. For instance, this number is for some groups (including types A, B, D and E) the sum of the dimensions of irreducible representations of a natural quotient of the Iwahori-Hecke algebra associated to the group, see [6]. Similarly, we now focus on CFC elements which are involutions. The main result is that there is always a finite number of such elements in all Coxeter groups, and we are able to characterize them in terms of words. We also use the characterization of CFC elements to enumerate CFC involutions according to their length in finite and affine Coxeter groups.

4.1. Finiteness and characterization of CFC involutions.

Theorem 4.1. *Let W be a Coxeter group and let $I(W)$ be its subset of involutions. The set $W^{CFC} \cap I(W)$ is finite. Moreover an element w belongs to $W^{CFC} \cap I(W)$ if and only if one (equivalently, any) of its reduced expressions \mathbf{w} satisfies, for any generator s in $\text{supp}(w)$, $|\mathbf{w}_s| = 1$, and for all t such that $m_{st} \geq 3$, $|\mathbf{w}_t| = 0$ (which means that two non commuting generators can not occur in \mathbf{w}).*

Proof. Let w be a CFC involution, let s be a generator in $\text{supp}(w)$ and \mathbf{w} be a reduced expression of w . Assume that $|\mathbf{w}_s| \geq 2$. Consider a cyclic shift $\mathbf{w}' = s\mathbf{w}_1$ of \mathbf{w} which begins with s . As w and s are involutions, \mathbf{w}' is an expression of an involution. Moreover as w is CFC, \mathbf{w}' corresponds to a FC element w' . According to [13], a FC element w is an involution if and only if $R(w)$ is palindromic, which means $R(w)$ includes the reverse of all of its members. Applying this to \mathbf{w}' allows us to say that \mathbf{w}' is commutation equivalent to a word $s\mathbf{w}_2s$. So a cyclic shift of \mathbf{w} is commutation equivalent to $ss\mathbf{w}_2$, which is in contradiction with the CFC property of w . Therefore we have $|\mathbf{w}_s| = 1$. We consider w' as before. As $R(w')$

is palindromic, we can conclude that all generators in $\text{supp}(w') = \text{supp}(w)$ commute with s .

Conversely, any element of W with reduced expression without two non commuting generators is an involution. \square

Remark 4.2. As a consequence, the number of CFC involutions in a Coxeter group W depends only on the edges of the Coxeter diagram, without taking into account the values m_{st} .

4.2. CFC involutions in classical types. Let us enumerate the CFC involutions in classical types, according to their Coxeter length. If W is a Coxeter group, we define $W^{CFCI}(q) := \sum_{w \in W^{CFC} \cap I(W)} q^{\ell(w)}$.

Theorem 4.3. *In types A , B , and \tilde{C} the following relations hold for all $n \geq 2$:*

$$\begin{aligned} A_n^{CFCI}(q) &= B_n^{CFCI}(q) = A_{n-1}^{CFCI}(q) + qA_{n-2}^{CFCI}(q), \\ \tilde{C}_n^{CFCI}(q) &= A_{n+1}^{CFCI}(q), \end{aligned} \quad (18)$$

and $A_0^{CFCI}(q) = 1$, $A_1^{CFCI}(q) = 1 + q$. Moreover, we can compute the generating function

$$A^{CFCI}(x) := \sum_{n=1}^{\infty} A_n^{CFCI}(q)x^n = x \frac{1+qx}{1-x-qx^2}.$$

Proof. The equality $A_n^{CFCI}(q) = B_n^{CFCI}(q) = \tilde{C}_{n-1}^{CFCI}(q)$ comes from Remark 4.2. Let w be a CFC involution in type A_n and let \mathbf{w} be one of its reduced expressions. If s_n belongs to $\text{supp}(w)$, by Theorem 4.1, s_{n-1} does not belong to $\text{supp}(w)$, and \mathbf{w} is equal to s_n concatenated to a CFC involution of type A_{n-2} . If s_n does not belong to $\text{supp}(w)$, w is a CFC involution of type A_{n-1} . This yields the expected relation (18). The generating function is computed through classical techniques, by using (18) and the initial values. \square

In particular, if $q \rightarrow 1$, we obtain the number of CFC involutions in type A_{n-1} , which is the $(n+1)^{\text{th}}$ Fibonacci number.

Theorem 4.4. *In types D and \tilde{B} , the following relations hold for all $n \geq 3$:*

$$\tilde{B}_{n-1}^{CFCI}(q) = D_n^{CFCI}(q) = D_{n-1}^{CFCI}(q) + qD_{n-2}^{CFCI}(q), \quad (19)$$

$$D_{n+1}^{CFCI}(q) = qA_{n-3}^{CFCI}(q) + (1+2q+q^2)A_{n-2}^{CFCI}(q), \quad (20)$$

and $D_1^{CFCI}(q) := 1$, $D_2^{CFCI}(q) = 1 + 2q + q^2$, $D_3^{CFCI}(q) = 1 + 3q + q^2$. Moreover, we can compute the generating function

$$D^{CFCI}(x) := \sum_{n=0}^{\infty} D_{n+1}^{CFCI}(q)x^n = \frac{1 + (2q + q^2)x}{1 - x - qx^2}.$$

Proof. The equality $\tilde{B}_{n-1}^{CFCI}(q) = D_n^{CFCI}(q)$ comes directly from Remark 4.2. To prove (20), let w be a CFC involution in type D_{n+1} and let \mathbf{w} be one of its reduced expressions. If s_1 belongs to $\text{supp}(w)$, by Theorem 4.1, s_2, t_1, t_2 do not belong to $\text{supp}(w)$, and \mathbf{w} is equal to s_1 concatenated to a CFC involution of type A_{n-3} . If s_1 does not belong to $\text{supp}(w)$, \mathbf{w} is a CFC involution of type A_{n-1} concatenated to t_1, t_2, t_1t_2 or nothing. This shows (20).

By using this, we can rewrite the expected recurrence relation in Equation (19) for the polynomials $D_n^{CFCI}(q)$ into a recurrence relation involving the polynomials

$A_n^{CFCI}(q)$ that we can check by using (18) (in the same way as we did for the proof of Proposition 3.9). The generating function comes from classical techniques, by using the recurrence in the second equality of (19), together with the initial values. \square

If $q \rightarrow 1$, we obtain the number of CFC involutions in type D_{n+1} , which leads to a Fibonacci-type sequence with starting numbers 1 and 4.

Theorem 4.5. *In type \tilde{A} , the following relation holds for $n \geq 2$:*

$$\tilde{A}_n^{CFCI}(q) = \tilde{A}_{n-1}^{CFCI}(q) + q\tilde{A}_{n-2}^{CFCI}(q), \quad (21)$$

where $\tilde{A}_0^{CFCI}(q) := 1$, $\tilde{A}_1^{CFCI}(q) = 1 + 2q$. Therefore, we can compute the generating function

$$\tilde{A}^{CFCI}(x) := \sum_{n=1}^{\infty} \tilde{A}_{n-1}^{CFCI}(q)x^n = x \frac{1 + 2qx}{1 - x - qx^2}.$$

Proof. Let w be a CFC involution in type \tilde{A}_{n-1} and let \mathbf{w} be one of its reduced expressions. If s_0 belongs to $\text{supp}(w)$, by Theorem 4.1, s_{n-1} and s_1 do not belong to $\text{supp}(w)$, and \mathbf{w} is equal to s_0 concatenated to a CFC involution of type A_{n-3} . If s_0 does not belong to $\text{supp}(w)$, w is a CFC involution of type A_{n-1} . This leads to the relation:

$$\tilde{A}_{n-1}^{CFCI}(q) = qA_{n-3}^{CFCI}(q) + A_{n-1}^{CFCI}(q).$$

Using this, we are able to compute the generating function $\tilde{A}^{CFCI}(x)$ by multiplying by x^n , summing over $n \geq 2$ and using the generating function $A^{CFCI}(x)$ obtained in Theorem 4.3. The recurrence relation (21) follows directly from the rational expression of $\tilde{A}^{CFCI}(x)$. \square

Remark 4.6. We also have

$$q^n \tilde{A}_{n-1}^{CFCI}(1/q^2) = L_n(q),$$

where $L_n(q)$ is the n^{th} Lucas polynomials, defined explicitly (see sequence A114525 in [12]) by $L_n(q) = 2^{-n}[(q - \sqrt{q^2 + 4})^n + (q + \sqrt{q^2 + 4})^n]$. This equality can be proved by using generating functions.

Theorem 4.7. *In type \tilde{D} , the following relation holds for $n \geq 4$:*

$$\tilde{D}_{n+2}^{CFCI}(q) = \tilde{D}_{n+1}^{CFCI}(q) + q\tilde{D}_n^{CFCI}(q), \quad (22)$$

with $\tilde{D}_4^{CFCI}(q) = 1 + 5q + 6q^2 + 4q^3 + q^4$ and $\tilde{D}_5^{CFCI}(q) = 1 + 6q + 10q^2 + 6q^3 + q^4$. We can therefore compute the generating function:

$$\tilde{D}^{CFCI}(x) := \sum_{n=2}^{\infty} \tilde{D}_{n+2}^{CFCI}(q)x^n = x^2 \frac{1 + 5q + 6q^2 + 4q^3 + q^4 + x(q + 4q^2 + 2q^3)}{1 - x - qx^2}.$$

Proof. Let w be a CFC involution in type \tilde{D}_{n+2} and let \mathbf{w} be one of its reduced expressions. If s_1 belongs to $\text{supp}(w)$, by Theorem 4.1, s_2 , t_1 and t_2 do not belong to $\text{supp}(w)$, and \mathbf{w} is equal to s_1 concatenated to a CFC involution of type D_{n-1} . If s_1 does not belong to $\text{supp}(w)$, \mathbf{w} is a CFC involution of type D_n concatenated to t_1 , t_2 , t_1t_2 or nothing. This leads to the relation:

$$\tilde{D}_{n+2}^{CFCI}(q) = qD_{n-1}^{CFCI}(q) + (1 + 2q + q^2)D_n^{CFCI}(q).$$

One can then use this and (19) to check that (22) is satisfied. Finally, $\tilde{D}^{CFCI}(x)$ is computed by summing (22) over $n \geq 4$ and using the initial values. \square

If $q \rightarrow 1$, we obtain the number of involutions in type \tilde{D}_{n+2} , which is a Fibonacci-type sequence with starting numbers 10 and 7.

5. OTHER QUESTIONS

In Sections 2 and 3, we obtained two q -analogs of the number of CFC elements in finite types. The first, in type A , corresponds to permutations avoiding 321 and 3412, taking into account their Coxeter length (see [17]). The second, in type D , is apparently new. One may wonder if it corresponds to another combinatorial object.

We can notice that if W is a finite or affine Coxeter group, the generating function of CFC elements is a rational fraction. This is in fact true for all Coxeter groups, as will be proved in the forthcoming work [11].

6. ACKNOWLEDGEMENTS

We would like to thank M. Macauley for pointing out reference [10] on logarithmic elements, and T. Marquis for valuable remarks on the infinite number of non logarithmic CFC elements. Finally, we also thank P. Nadeau for interesting comments and discussions on an earlier version of this manuscript.

REFERENCES

- [1] R. Biagioli, F. Jouhet, P. Nadeau, *Fully commutative elements in finite and affine Coxeter groups*, *Monatsh. Math.* **1** (2015), 1–37.
- [2] A. Björner, and F. Brenti, *Combinatorics of Coxeter groups*, Springer (2005).
- [3] T. Boothby, J. Burkert, M. Eichwald, D. C. Ernst, R. M. Green, and M. Macauley, *On the cyclically fully commutative elements of Coxeter groups*, *J. Algebraic Combin.* **1** (2012), 123–148.
- [4] M. Develin, M. Macauley, V. Reiner, *Toric partial orders*, preprint arXiv:1211.4247 (2012), 18 pages.
- [5] C. K. Fan, *A Hecke algebra quotient and properties of commutative elements of a Weyl group.*, Phd thesis, M.I.T. (1995).
- [6] C. K. Fan, *Structure of a Hecke Algebra Quotient*, *J. Amer. Math. Soc.* **1**(1997), 139–167.
- [7] J. Graham, *Modular Representations of Hecke Algebras and Related Algebras*, PhD thesis, University of Sydney (1995).
- [8] C. R. H. Hanusa, B. C. Jones, *The enumeration of fully commutative affine permutations*, *European J. Combin.* **31** (2010), 1342–1359.
- [9] J. E. Humphreys, *Reflection groups and Coxeter groups*, Volume 29 of Cambridge Studies in Advanced Mathematics, Cambridge University Press, Cambridge (1990).
- [10] T. Marquis, *Conjugacy classes and straight elements in Coxeter groups*, to appear in *Journal of Algebra*, preprint arXiv:1310.1021v2 (2014), 12 pages.
- [11] M. Pétréolle, *Rational generating function for cyclically fully commutative elements*, in preparation (2014).
- [12] N. J. A. Sloane, *The on-line encyclopedia of integer sequences* (2013).
- [13] J. R. Stembridge, *On the fully commutative elements of Coxeter groups*, *J. Algebraic Combin.* **4** (1996), 353–385.
- [14] J. R. Stembridge, *Some combinatorial aspects of reduced words in finite Coxeter groups*, *Trans. Amer. Math. Soc.* **4** (1997), 1285–1332.
- [15] J. R. Stembridge, *The enumeration of fully commutative elements of Coxeter groups*, *J. Algebraic Combin.* **7** (1998), 291–320.
- [16] D. E. Speyer, *Powers of Coxeter elements in infinite groups are reduced* *Proc. Amer. Math. Soc.* **4** (2009), 1295–1302.
- [17] B. E. Tenner, *Pattern avoidance and the Bruhat order*, *J. Combin. Theory Ser. A* **5** (2007), 888–905.

INSTITUT CAMILLE JORDAN, UNIVERSITÉ CLAUDE BERNARD LYON 1, 69622 VILLEURBANNE
CEDEX, FRANCE

E-mail address: `petreolle@math.univ-lyon1.fr`

URL: `http://math.univ-lyon1.fr/~petreolle`