

SUSTAINABLE PALM OIL SUPPLY CHAINS: COMPLEXITY, CUSTODY AND CONTENTION

Paul D. Jensen^{1,3}, Linda Whicker², Pauline Deutz³

¹ *School of Engineering, University of Hull*

² *University of Hull Business School*

³ *Dept. of Geography, Environment and Earth Sciences, University of Hull*

Email: p.jensen@hull.ac.uk; l.whicker@hull.ac.uk; p.deutz@hull.ac.uk

Abstract

Purpose: The sustainability of oil palm cultivation is highly contentious. Demand for the product is strong, albeit with the market being largely divided between the bulk sale of oil to Asian markets and premium certified sustainable palm products to Europe. These disparate end-user markets place different production demands on upstream suppliers. This paper will explore the complex and contentious nature of sustainability in the context of the palm oil supply chain. Specifically, this study considers the economic, ethical and environmental aspects emerging from efforts to create sustainable palm oil supply chains with a view to developing supply chain ‘regulation without government’ as a possible solution.

Research Approach: Case-based research involved empirical observation of upstream actors, document analysis and consequent theory testing through semi-structured interviews with growers, mills, refiners, certifiers of sustainable palm oil, NGOs, retailers and leading European manufacturers of palm oil containing products.

Findings and Originality: Different interpretations of sustainability have created conflict at the point of production with what are perceived to be Western values regularly conflicting with the perceived needs of palm oil producing countries. Traceable supply chain custodies created by large downstream manufacturers may isolate smallholders and reduce their ability to be incorporated into some certification schemes. Though downstream actors can pay a significant value-chain premium for certified products, due to a wider lack of global demand for certified palm oil, sustainable products are ending up in other supply chains with no premium being paid to growers.

Research Impact: The presented study is relatively unique in palm oil research for its empirical grounding, bringing together the first-hand insight, thoughts and perceptions of stakeholders throughout the supply chain. Additionally, this paper contributes to the reactive-proactive continuum theory for sustainable supply chain practices by discussing how key stakeholders influence behaviour.

Practical Impact: Insights from this research will help raise awareness of the supply chain dynamics of the palm oil industry, the challenges faced by upstream buyers and how well-meaning efforts to support socio-economic development, from various stakeholders, potentially harms efforts to drive sustainable production of oil palm. Alternative routes for developing sustainable supply chains should be initiated from within the supply chains rather than solely through external activism. The implications of this are far-reaching as the consumer base for palm oil continues to grow globally.

Introduction

The oil palm is the most productive of the commercially grown oil crops. In terms of yield per hectare, it is up to 10x more productive than the likes of sunflower, soy and rapeseed (Sime Darby, 2014). Global demand for palm oil has steadily grown to a point where it dominates world oil markets with production, in May 2016, standing at 65 million tonnes (USDA, 2016). Reasons behind oil palm's growth as a product and industry is multifaceted but largely driven by demand for cheap readily available foodstuffs by growing populations in Asia amplified by other regions' increasing use of palm oil as an affordable substitute for trans-fats and animal by-products (e.g., Buckland, 2005; Rival & Levang, 2014). Oil palms grow almost exclusively in humid tropical areas leading its commercial production to be largely centred in equatorial and equator bordering countries, most notably those of Southeast Asia. Indeed, as a commodity, it has become key in the development of several countries (e.g., Sayer et al., 2012), notably Indonesia and Malaysia who together produce 86% of the world's current supply of palm products. The tangible benefits that the palm oil industry has brought to producing countries and approximately 3 million smallholder farmers are manifold (Sayer et al., 2012; Majid Cooke et al., Submitted). For some smallholders and their families, oil palm cultivation has in fact become a 'livelihood strategy' (Cramb & Sujang, 2013)

Notwithstanding benefits to many, oil palm cultivation is associated with significant environmental impact, not least the destruction of some of the oldest rainforests in the world and its endemic fauna (e.g., Fitzherbert et al., 2008; Wilcove & Koh, 2010). Furthermore, though some indigenous peoples have benefitted, others have lost ancestral lands and, in some cases, their way of life (e.g., forest nomads such as the Penan in Borneo). Countering this, some have raised the above arguments that oil palm brings much needed development to rural poor. At the same time, it has been suggested that palm oil production may not be the direct cause of deforestation; instead, other industries such as logging are responsible for the destruction of primary tropical forests (e.g., Fitzherbert et al., 2008). Whilst these claims are credible in some specific cases, such rationale does not meet the needs and operational policies of many businesses and their supply chains. Companies need to be seen to be not complicit in environmental and ethical issues associated to their industry or raw materials. Western companies especially are subject to intensive scrutiny and potentially brand damaging campaigns by NGOs and are increasingly encouraged to take responsibility for their wider actions and their impacts on the environment and society (Wolf, 2014; Hörisch et al., 2015). Such responsibility can contribute to large demand side businesses increasingly placing sustainable production and social responsibility requirements on suppliers (Ras and Vermeulen, 2009). In the West, the implementation and conveyance of an environmental policy along a supply chain is relatively commonplace (Grosvold et al., 2014). Technical and feasibility questions over the ability of smaller companies with limited operational resources to work to larger buyers environmentally congruent policies, however, exist. Such questions, when dealing with an industry that is focussed in the developing world and underpinned by several million small farmers, attract additional questions relating to business policy and ethics.

Research Approach

This study examines how companies are seeking to protect their image in the context of operating within a complex supply chain that crosses disparate geographic regions in terms of national development and business cultures. Given the contentious nature of palm oil in the West, how to influence and manage supply chains originating in developing countries is a major issue for European

businesses, not least the extent to which other supply chain partners can be relied upon to comply with recognised standards. Specifically we ask: how have consumer facing companies in the palm oil supply chain used product certification to promote the perceived sustainability of their product. In particular, the implementation of supply chain custodies and much vaunted 'traceability', as a perceived mechanism for industry sustainability, are assessed. The presented exploratory research draws on first-hand practitioner experience of developing strategies for improving the environmental performance of businesses, in-the-field personal observations of palm oil industry stakeholders in Southeast Asia and extensive document analysis. Additionally, stakeholders covering all positions of the oil palm supply chain were interviewed ($n = 7$), including representatives of major retailers, multinational consumer goods manufacturers and Malaysian refineries, mills and oil palm estates. Interested parties external to the supply chain were also interviewed ($n = 4$), including industry certifiers and NGOs based both in the UK and Southeast Asia.

Literature and Research Context

Sustainable Supply Chain Management (SSCM) involves the coordination and integration of the social, environmental and economic goals of its actors (Carter et al., 2008). Much has been written about the environmental and ethical dimensions. However, Closs et al. (2011) suggest that there is a need to develop theory as to how SSCM can contribute more broadly to improving the effectiveness of supply chains. As sustainability issues arise, companies require effective strategies to anticipate and mitigate for any detrimental consequences. SSCM should therefore incorporate more proactive strategies rather than simply the reactive ones that arise from responses to external pressures from stakeholders (Wolf, 2014). Reinforcing this idea, a recent study has shown that companies utilise predominantly third-party certifications and supplier training as evidence for sustainable management practices, thereby showcasing their proactive strategy credentials (Grosvold et al., 2014). However, whilst many companies formalise these practices as requirements for doing business, some have no systems in place to measure if they have been achieved, therefore demonstrating a decoupling of the strategy and its measurement. Both decoupling and even 'loose coupling' of company policy and actual practice, however, can be a high risk approach to SSCM, potentially leading to environmental and reputational damage (Grosvold et al., 2014). Thus, proactive SSCM is increasingly a facet of large companies, particularly those with management systems that demand continual improvement. Realising proactive SSCM initiatives and policies, however, requires and should entail supply chains to think about the operation of the whole system, not just one or an isolated part of it (Grosvold et al., 2014). This wider relationship between stakeholder pressure and SSCM, nevertheless, has received little attention (Wolf, 2014)

Given large companies' constant assessment of risk within their supply chains and need to protect their brands from bad publicity, not least that created by NGO campaigns, the palm industry has been subject to the development of several schemes aimed at raising standards and the industry's image. Some are national compulsory schemes that lean toward the socio-economic development aspects of sustainability - such as the Indonesian Sustainable Palm Oil (ISPO) scheme - and others are voluntary third-sector schemes that have a more general and wide-ranging sustainability remit - such as the Roundtable on Sustainable Palm Oil (RSPO). Of all the schemes, RSPO is the most mature and has the widest international reach and credibility amongst the private sector, particularly in Europe. RSPO was the product of several businesses and the WWF coming together to create a mechanism for ensuring palm oil was produced to sustainability standards agreeable to its membership. RSPO

certification standards are formed around performance indicators which focus on several guiding principles, ranging from 'Commitment to Transparency', 'Use of Appropriate Best Practices by Growers and Millers', 'Environmental Responsibility and Conservation of Natural Resources and Biodiversity' through to 'Responsible Consideration of Employees, and of Individuals and Communities Affected by Growers and Mills' (RSPO, 2013).

Modes of Certification

Any organisation can become a *member* of RSPO. However, to *sell* Certified Sustainable Palm Oil (CSPO) a group of smallholders, an estate, plantation and/or mill has to be audited by a third-party against the Roundtable's 69 performance indicators and overriding 'Principles & Criteria' (see RSPO, 2013). Following a successful third-party audit and RSPO certification, CSPO produced by a mill can enter the palm product supply chain via one of four methods. Each method has to be *separately* certified to RSPO supply chain standards (separate to the P&C standard) to allow end-users to claim that their product truly is, or supports, CSPO. The four supply chain options are:

1. 'Identity Preserved' (IP) CSPO; which is physically produced by RSPO certified producers, sold at source and kept separate from non-CSPO palm oil from the point of production through to the point at which it is ready for end-use within a given product.
2. 'Segregated' CSPO; palm oil which has been produced by a RSPO certified producer but the oil is mixed with that of other certified RSPO certified producers. The mixed CSPO is kept apart from non-CSPO oil throughout its production through to its supply to manufacturers.
3. 'Mass Balance' (MB) system. This supply chain system entails a known percentage of CSPO being mixed, potentially at more than one location, with non-CSPO oil. Users of MB palm oil are permitted to claim they *contribute* to the production CSPO (to a given percentage).
4. 'Book and Claim'; involves issuing what are known as 'GreenPalm certificates' to growers. One certificate is issued to a grower for every tonne of RSPO certified palm oil they produce. Though there is no guarantee that the palm used by a downstream business purchasing GreenPalm certificates has indeed been grown in a socially responsible or sustainable manner, they are permitted to claim that they actively *support* the production of CSPO.

Interim Findings

As it is theoretically possible to determine where, how and by whom oil palm was grown using the IP CSPO supply chain option, it is thus increasingly proving to be the route by which large brand name companies, particularly European companies, are sourcing their palm oil, kernel and other palm based materials (e.g., Unilever, 2014; Nestlé, 2015; Certifier1 Interview, 2015; CGM1 Interview, 2016; Retailer1 Interview, 2016). This system, however, requires all members of the supply chain to be audited and certified, including any smallholder farmer supplying to the mill. For many smallholders this is not possible for financial reasons or disinterest (Martin et al., 2015; Majid Cooke et al., Submitted; Jensen et al., In Prep.). Technically, it is not possible for a smallholder to be individually certified. This is largely due to a lack of access to capital to pay for cultivation improvements and/or the auditing and certification process whilst the sometimes complicated and contested nature of smallholder land ownership also restricts smallholders' ability to join the likes of RSPO. As such, many proactive businesses have circumvented these problems by encouraging the creation of smallholder groups linked to certified mills (NGO1 Interview, 2015). The mill and other stakeholders invariably provide the training and tools necessary to allow smallholders to be certified. In turn, smallholders are asked to sell their FFB to the supporting mill. For some big brands support of smallholders,

through their supplying mills and NGOs, has simply formed part of their CSR exercises rather than a way of securing supplies of FFB. One of the largest palm users, Unilever, has stated: “We see the importance of sourcing palm oil from smallholders and will prioritize purchasing from suppliers that have volumes that can be traced to known smallholders. The biggest challenge we face is increasing the productivity of smallholders in the sector, and ensuring that the socio-economic benefits of growing palm are felt by smallholders and local communities” (Unilever 2014: 2). However, such a model of engagement does not help those smallholders who for varying reasons will not or are not able to join a certified group of growers. Indeed, some smallholders show a distinct disinterest in working to the standards required by certifying schemes and, more importantly, by downstream buyers (Martin et al., 2015; Jensen, In Prep.) There is thus an ethical problem for Western companies, particularly those with policies relating to suppliers and working to recognised standards.

Stakeholder Perspectives on Certification

A sample of study findings in the form of stakeholder observations are presented as Table 1 and augmented by Figure 1, below. Aside from observation 5 within Table 1, made by both NGOs and one certifier, each point is representative of comments made by all interviewees.

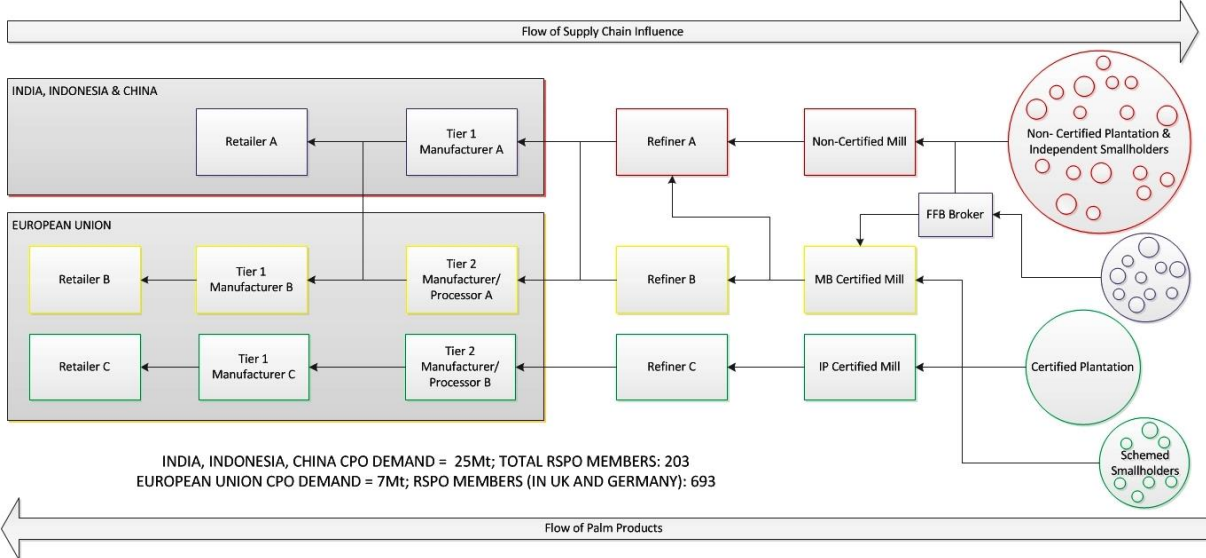

Figure 1: Schematic of Palm Oil Supply Chains

Observation	Pertinent Comments
<p>1. Multinational corporations, sometimes in response to environmental and social NGO media campaigns, as much as their own SC risk management and policies, have sought to create IP chains of custody. The palm product supply chain, however, is inherently complex and determining custody is difficult (e.g., Fig.1).</p>	<ul style="list-style-type: none"> • Much complexity derives from the industry’s 3 million smallholders who are: “largely invisible in the supply chain” (NGO1, 2015). • Invisibility of smallholders and their practices are exasperated by the emergence of Fresh Fruit Bunch (FFB) traders. Though traders are aware of how their palm was cultivated, they do not necessarily know how the smallholders they have purchased from operate: “no one keeps track of that, nobody has any idea whether the farmer is planting on a forest reserve or whether he is encroaching on a forest reserve whether he is planting on peat area which he is not supposed to be in, he is not managing it well or whether he has got his children working for him” (NGO1, 2015).
<p>2. The complexity of oil palm</p>	<ul style="list-style-type: none"> • Traceability “does not [really] equate to sustainability”. A company publicised that 94% of the palm oil they use can be

<p>SCs and consequently the use of traceability as a tool for implementing sustainability is questioned.</p>	<p>traced back to more than a thousand mills. Effectively the company had traced their supplies back to: <i>“about half of the mills on the planet”</i>. <i>“Does that give you any reassurances as a consumer?”</i> (Certifier1, 2015).</p> <ul style="list-style-type: none"> • CGM2: given the convoluted route palm oil takes from the field through umpteen processing and logistics steps to the point where a small fraction of palm is used as stearin in a given pastry product, unlike traceability in other industries, CSPO IP: <i>“traceability is hilarious”</i>. <i>“This is why it is a bit cloak and dagger about what people talk about”</i> (CGM2, 2016).
<p>3. IP SC certification for CSPO potentially excludes and/or isolates smaller growers who are unable to meet the costs of certification but rely on the income from oil palm for their livelihoods.</p>	<ul style="list-style-type: none"> • Although it is not impossible to certify smallholders and thus allow access to the IP and segregated supply chains, it <i>“involves a lot of work most companies are not interested to invest in”</i>. <i>“In a situation whereby a mill has already sufficient FFB coming in from estates that are certified, they have an option to stop sourcing from non certified sources to pursue a segregated (or identity preserved) model”</i> (NGO2, 2016). • <i>“...a large company can establish its own chain of custody, yeah, that is happening. I am not going to criticise them or question them or make any other comments other than I can understand that it does, or it can, leave smallholders out of that equation”</i> (CGM1, 2016).
<p>4. One of the biggest challenges in relation to getting all growers to commit to production of CSPO, and thus being able to access certified supply chains, is the lack of a premium for its production.</p>	<ul style="list-style-type: none"> • A <i>“premium should be realised”</i> [by growers] for the cost they incur working to the demands of downstream buyers; however, Despite their being an at times <i>“eye watering”</i> premium related to the logistics required to transport segregated material, there is no fixed premium for growers (CGM1, 2016). • <i>“The issue is, what irritates everybody... not all of it [CSPO] is sold as certifiable oil”</i>; thus the issue with growers and smallholders who are asked by buyers to adopt costly CSPO standards: <i>“they turn around and say: well why should I bother because all the certified oil is not being consumed anyway. It is a horrible catch-22 the situation”</i> (CGM1, 2016).
<p>5. In some cases certification costs could be better spent helping growers improve their cultivation practices.</p>	<ul style="list-style-type: none"> • Certification costs would be better spent aiding small farmers: <i>“to adopt sustainable cultivation methods by providing training, resources and sharing best management practices”</i> (NGO1, 2015). • <i>“Money should be directly used to empower smallholders instead of being pumped into unnecessary administrative costs”</i> (NGO2, 2016).
<p>6. Many bigger businesses, particularly in Europe, are actively engaged in and keen to at least be seen to ‘do the right thing’.</p>	<ul style="list-style-type: none"> • <i>“[There] are big consumer companies that have quite vigorous programmes to try to better support and include smallholders: companies acknowledge the issue and I think are trying to do something about it.”</i> (CGM1, 2016).

Table 1: Interim Study Observations and Quotes Exemplifying Interviewee Comments

Discussion and Conclusion

The following discussion is presented in the context of palm oil supply chain ‘complexity’, ‘custody’ and ‘contention’. These terms proved prevalent throughout this study and in a variety of ways represent the core elements of palm oil within the context of sustainable supply chains.

Complexity: supply chains of all forms can be seen as complex systems, with multiple actors, interdependencies and evolving influences and properties (e.g., Viswanadham and Kameshwaran, 2013). The ways in which supply chain actors are affected by system influences is nuanced by their reactions to how these influences can reverberate through the chain. The policies and pressures faced by powerful Western palm oil buyers have created supply chain platforms that meet their needs. These same platforms, created to address one set of sustainability and/or specific ethical issues, arguably create other issues within the supply chain 'system'. These issues are heightened and complicated by the oil palm industry's inherent complexity of possessing millions of suppliers who are deemed to be 'largely invisible'. The oil palm industry provides a clear example of clashing disparate national culture, ethics and agency, particularly in relation to product supply chains and sustainability. Understandably, the likes of Indonesia have their own definition of sustainable palm oil which meets their country's desire for socio-economic development and have willing likeminded markets for their products, particularly domestically and overseas in the form of India. Such definition, however, does seemingly not fit with, in particular, European ideals regards to how consumers' 'favourite brands' operate and produce their goods and to the detriment of who or what. Some businesses are built on and keen on "*doing the right thing*" (CGM1, 2016). These same businesses are continually looking for options to do the right thing or be seen to be a 'good citizen' (e.g. Wolf, 2014). The products of the oil palm are all fungible in the food and personal and home care industries, however shifting to a substitute raw material would, as a minimum, simply move environmental issues elsewhere. In fact, substituting palm for another of the common oil fruits, vegetables and/or seeds would arguably exasperate environmental issues given the amount of land and inputs that would be required to produce the current globally consumed volumes of palm oil. Thus, it seems, oil palm is here to stay and 'doing the right thing' becomes increasingly important.

Custody: traceability, albeit it seems the illusion of traceability, and taking custody of your supplies is the favoured option or 'right thing', for some. However, such action can and does draw criticism of an: "*I'm alright Jack attitude*" which is "*not good enough*" (CGM2, 2016). Such steps, furthermore, do not solve the wider contention attached to the oil palm industry. Adopting better, more resource efficient, more accountable cultivation practices, at least initially, takes capital, capital that many growers in the countries where oil palm cultivation takes place do not have. This position is exasperated by the lack of a notable premium for growers of CSPO. In turn, these two issues culminate to leave little capacity or indeed incentive for smaller estates and smallholders in developing nations to work to the standards demanded by European consumers, particularly as there are willing buyers for fruits potentially produced to questionable ethical and environmental standards. Perversely, however, in creating the administrative and logistics infrastructure and systems required to track certified FFB products through a supply chain, CGMs are paying premiums for CSPO that albeit increasingly manageable have at times been "*eye watering*" (CGM1, 2016). There is an obvious argument that such sums of cash and effort employed in creating segregated supply chain infrastructure, which *could* isolate and discriminate against the most vulnerable in the supply chain, could be better spent on the ground directly paying for better cultivation practices or simply used in an educating and enabling manner.

Instead of auditors, certifying bodies and logistics businesses profiting from a much needed drive for sustainably produced palm oil, it could be argued that the more ethical approach is to empower the industry's growers to work to the standards expected of an entity operating within a global supply

chain, possibly free from formal third-party certification. For many years downstream stakeholders have placed demands on suppliers through company policies created both by themselves and external pressures. This is often done with minimal regard for smaller enterprises' capacity to fulfil these requirements. As seen in other industries (see Grosvold et al., 2014), from a business perspective, it is arguably not good enough for smallholders to routinely claim ignorance or poverty in relation to sustainability (Jensen et al., In Prep.). However, it is arguably not ethical to also create exclusionary business practices, particularly when dealing with developing nations and their people. There is clearly capacity and sufficient NGO expertise and goodwill within the sphere of the oil palm industry to help smaller entities reach standards commensurate with social and environmental sustainability. Some businesses have made well-publicised efforts to do this; however the same businesses still pursue traceability of supplies. Although traceability can indeed be deemed to be the 'gold standard' when ensuring the provenance of some commodities, without efforts to ensure 100% compliance with accepted production standards, there are clear flaws with its application in complex oil palm supply chains.

Contention: it would seem from the upstream perspective of the supply chain and the countries these streams lay within, the more equitable CSPO supply chains are the peculiarly criticised MB and GreenPalm options. GreenPalm certificates in particular, which *notably* most of the larger users of palm oil have declared they are actively moving away from due to their lack of physical palm oil provenance, outwardly seem to be the only way of ensuring that all those wanting to produce FFB to sustainable standards can be rewarded, albeit minimally, for their efforts. There is, however, an intrinsic argument that one should not need a reward for doing the right thing. This is where environmental policies and commitments to *only* working with likeminded businesses are arguably useful. Given the pervasiveness of oil palm products in modern society, however, it is simply unrealistic to implement a 'do not buy' policy. And, where, suppliers within developing countries are involved, perhaps unethical. Those wishing to do the right thing, large or small, in the developed or developing world, are ultimately hampered by the willingness of some to purchase products emanating from areas where environmental congruence has evidently taken a backseat to profit and perceived 'development'. Indeed, markets for non-CSPO continue to be plentiful. Of the approximate 65 million tonnes of palm oil produced globally only 21% in 2015 was CSPO, of which approximately only 50% was actually sold as CSPO. It is apparent that a 'race to the bottom' currently has stronger legs than the European led 'race to the top'. Presently there is little market influence, either way, to organically promote the exclusive production of CSPO. Thus, with regional disagreement over the image and production of certified sustainable products, contention at both ends of the 'stream' will continue for the foreseeable future.

In sum: this study and its findings are relatively unique in being shaped by the observations of key stakeholders engaged in all aspects of oil palm supply chains. The presented insights contribute to the reactive-proactive continuum theory for sustainable supply chain practices and discussions on the role of supply chain stakeholders in establishing 'regulation without government'.

Acknowledgements

The authors would like to thank all interviewees for sharing their insight and experiences of the oil palm industry and efforts to implement supply chain sustainability. This project is funded by a British Council Newton Fund grant (172702808) to the University of Hull and Universiti Malaysia Sabah.

References

- Buckland, H. (2005), 'The Oil for Ape Scandal: How Palm Oil is Threatening Orang Utan Survival', London, UK: Friends of the Earth Trust.
- Carter, C.R. & Rogers, D.S. (2008), 'A Framework for Sustainable supply chain management; moving toward new theory', *International Journal of Physical Distribution and Logistics Management*, Vol. 38, pp. 360-387.
- Closs, D. et al. (2011), 'Sustainability to support end-to-end value chains: the role of supply chain management', *Journal of the Academy of Marketing Science*, Vol. 39, pp. 101–116.
- Cramb, R.A. & Sujang, P.S. (2013), 'The mouse deer and the crocodile: oil palm smallholders and livelihood strategies in Sarawak, Malaysia', *The Journal of Peasant Studies*, Vol. 40 pp. 129-154.
- Fitzherbert, E.B. et al. (2008), 'How will oil palm expansion affect biodiversity?', *Trends in Ecology & Evolution*, Vol. 23 pp. 538-545.
- Grosvold, J. et al. (2014), 'Squaring the circle, Management, measurement and performance of sustainability in supply chains', *Supply Chain Management: An International Journal*, Vol. 19/3, pp. 292–305.
- Hörisch, J. et al., (2015), 'Implementation of sustainability management and company size', *Business Strategy and the Environment*, Vol. 24, pp. 765-779.
- Jensen, P.D. et al. (In Preparation), 'Stakeholder Influence and Supply Chain Perceptions of Oil Palm Producing Smallholders in Southeast Asia', *Business Strategy and the Environment*.
- Majid Cooke, F. et al. (In Preparation) '*Oil Palm Cultivation as a Development Vehicle: Exploring Trade-Offs for Smallholders in East Malaysia*', Abingdon, UK: Routledge.
- Martin, S. et al. (2015), 'Small farmers and sustainability: Institutional barriers to investment and innovation in the Malaysian palm oil industry in Sabah', *Rural Studies*, Vol. 40, pp. 46-58.
- Nestlé (2015), '*Progress Report on Responsible Sourcing of Palm Oil*', Vevey, Switzerland: Société des Produits Nestlé S.A.
- Ras, P. J. & Vermeulen, W. J. V. (2009), 'Sustainable production and the performance of South African entrepreneurs in a global supply chain', *Sustainable Development*, Vol. 17, pp. 325-340.
- Rival, A. & Levang, P. (2014), '*Palms of Controversies: Oil Palm and Development Challenges*', Bogor, Indonesia: Center for International Forestry Research.
- RSPO (2013), '*Principles and Criteria for the Production of Sustainable Palm Oil*', Kuala Lumpur, Malaysia: Roundtable on Sustainable Palm Oil.
- Sayer, J. et al. (2012), 'Oil palm expansion transforms tropical landscapes and livelihoods', *Global Food Security*, Vol. 1, PP 114-119.
- Sime Darby (2014), '*Palm Oil Facts and Figures: April 2014*', Sime Darby Plantation Factsheet.
- Unilever (2014), '*Sustainable Palm Oil Progress Report 2014*'. Sharnbrook, UK: Unilever PLC.
- USDA (2016), '*Oil Seeds: World Markets & Trade: May 2016*', US: Department of Agriculture.
- Viswanadham, N. & Kameshwaran, S. (2013), '*Ecosystem-Aware Global Supply Chain Management*', Singapore: World Scientific Publishing.
- Wilcove, D. & Koh, L. (2010), 'Addressing the threats to biodiversity from oil-palm agriculture', *Biodiversity and Conservation*, Vol. 19, pp. 999-1007.
- Wolf, J. (2014), 'The Relationship between Sustainable Supply Chain Management, Stakeholder Pressure and Corporate Sustainability Performance', *Journal. Business Ethics*, Vol. 119, pp. 317–328.