

16<sup>th</sup> Australasian Fluid Mechanics Conference  
Crown Plaza, Gold Coast, Australia  
2-7 December 2007

## Evaluation of a Proposed Dust Ventilation/Collection System in an Underground Mine Crushing Plant

J. Naser<sup>1</sup>, F. Alam<sup>2</sup>, M. Khan<sup>3</sup>

Faculty of Engineering & Industrial Science

<sup>1</sup>Swinburne University of Technology, Victoria, 3122 AUSTRALIA

<sup>2</sup>School of Aerospace, Mechanical and Manufacturing Engineering  
RMIT University, Melbourne, VIC 3083, AUSTRALIA

<sup>3</sup>Centre for Multiphase Processes, University Newcastle, NSW 2308, Australia

### Abstract

Computational Fluid Dynamics (CFD) modelling of a dust collection system in an underground mine crushing plant was carried out. Dust was collected/absorbed through the holes along the top edge of Run of Mine (ROM) bin. The dust collection performance of the system is summarised. The detail results are presented in the form of velocity vectors and dust concentration iso-surface contours. Time dependent dust concentration iso-surfaces are also presented.

Dust was found to be well contained within the crusher bin and stands out as a viable option. However, the velocity magnitudes were found to be very high in and around the whole exits, which has the potential to lead to undesirable pressure drop and generation of noise.

### Introduction

Extraction of ore using block caving method is common in underground mines. The ore extracted from draw point is hauled to underground crushing station using load haul dump (LHD) trucks and tipped or dropped into ore or ROM bin. A typical LHD truck tipping into a ROM bin is shown in Fig.1. Dust is released during the tipping process. The released dust often causes visibility problem to the LHD drivers. The released/dispersed dust is expected go out along with the outgoing ventilation air. In the conventional approach the outgoing dust laden air is collected through an exit in the ceiling. The dispersion of dust is governed by local airflow controlled by the mechanical ventilation system and is made very complex by the localised turbulent air motion generated by large volumes of material undergoing drop feed [1]. Computational Fluid Dynamics (CFD) simulation has been successfully used in the past [2] to evaluate the ventilation of underground crushing plant. The study [2] also carried out experimentation to qualitatively validate the CFD results and gain more insight into the physics of the dust dispersion by the drop feed.

This paper undertakes CFD modelling of a less conventional dust collection systems proposed for a mine, details not disclosed for confidentiality reasons. Dust was collected/absorbed through the holes along the top edge of ROM bin. The idea was to contain the dust released from the bin to within the bin. Fig. 2 shows the geometry of the four tunnels and the bin, hereafter referred to as tippie, investigated in this study. The merits of the proposed dust collection system were evaluated and remarks/recommendations made. Simulations were conducted for three cases: empty, half, and full ore bin scenarios.

The paper presents the flow geometries investigated, computational grid used for modelling the geometry and the computational results obtained under the specified operating conditions. The CFD software FIRE [3] was used for this investigation.

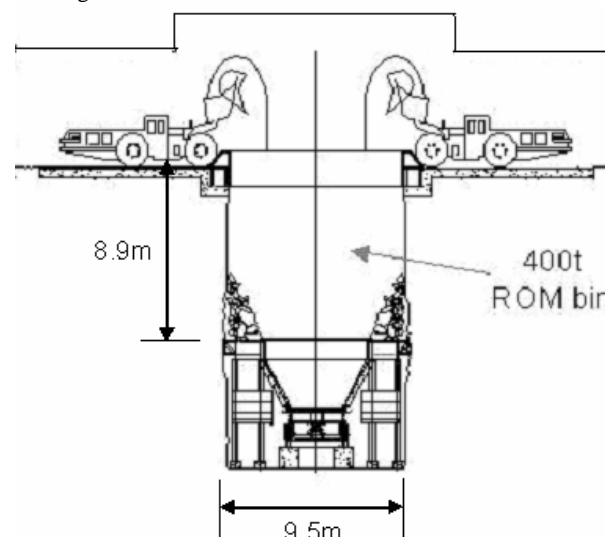

Fig.1 Typical LHD trucks tipping into a ROM bin

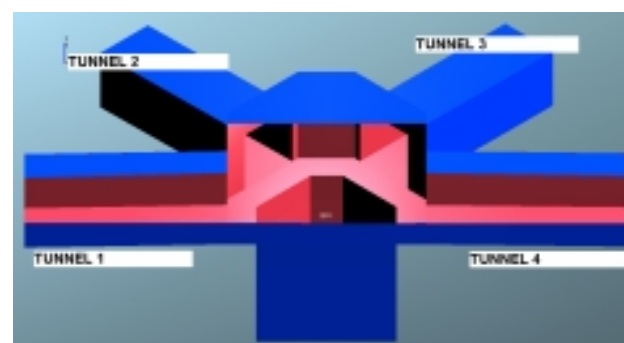

Fig.2 Geometry of the tippie showing the 20 cm holes on the edge of ROM bin

### Computational Method

A typical computational grid arrangement, out of the three used for different bin content scenarios (empty, half empty & full) is shown in Fig. 3. The solution domain and the computational grids were constructed from the CAD drawings. Time averaged equations were solved to obtain the values of velocities, pressure,

dust concentrations and turbulence parameters. The multi-phase capability available in FIRE was used to model the air-dust flow system. Air was considered as the continuous phase (1<sup>st</sup> Phase) and dust, with a density of 2000kg/m<sup>3</sup> and a uniform particle size of 5 micron, was considered as the dispersed (2<sup>nd</sup> phase). Both transient and steady state conditions were modelled. In the transient or time dependent situation, efforts were made to simulate the cyclic loading pattern observed in the real life operation (one LHD feed per min). A 5m<sup>3</sup> of air-dust mixture (representing the volume of air displaced from the bin by each LHD feed) with a dust loading of 1% was released from the bottom of the bin over a period of 5 sec. (i.e a flow rate of 1m<sup>3</sup>/sec) The cycle was repeated every 60 seconds and a total of 10 cycles, i.e. a total of 600 seconds in real time was simulated. Under the steady state situation a continuous release of 5m<sup>3</sup>/60=0.0833m<sup>3</sup>/sec. of air-dust mixture was maintained from the bottom of the bin. The simulations were carried out under isothermal (20<sup>0</sup>C) conditions. The volume flow rates of air through each tunnel and the air-dust mixture released from the bin, for all the three case scenarios investigated, are given in the table 1.

table 1 Volume flow rates (boundary conditions)

Inlets	Air Volume flow rates m <sup>3</sup> /sec		Dust loading % volume
	Steady	Transient (60 sec/cycle)	
Tunnel-1	20.1	20.1	0.0
Tunnel-2	3.3	3.3	0.0
Tunnel-3	10.8	10.3	0.0
Tunnel-4	22.6	22.6	0.0
Bin (bottom of bin)	0.0833	1.0 for first 5 sec 0.0 for next 55 sec	1.0

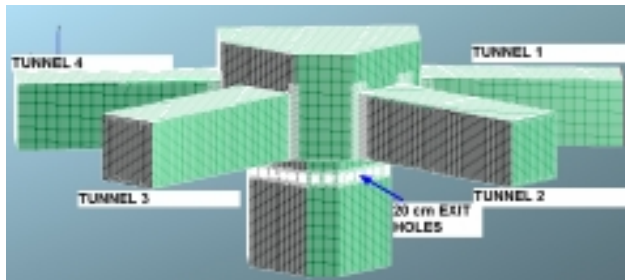

Fig.3 A typical computational grid used (empty bin scenario)

## Results and Discussions

The overall dust collection performance is summarised in table 2. The detail results are presented in the form of velocity vectors on vertical and horizontal planes and dust concentration iso-surface contours in the solution domain. As the time dependent effects were introduced through air-dust mixture released from the bottom of the bin (see table 1), it was not expected to alter the overall flow dynamics of the domain substantially. However, the dust concentration pattern will be altered. Hence, the dust concentration iso-surface contours obtained for both transient and steady state cases are presented in this paper. The time dependent videos of dust concentration iso-surfaces were also developed but could not be made available with this paper. The velocity vectors obtained for steady state cases are presented in this paper.

## Dust Collection Performance Summary

Dust released and dust collected under the steady state cases are presented in table 2. Dust was found to be well contained within the bin. This is further demonstrated in Figs. 10 to 15. Thus the proposed system of collecting dust through the holes along the top edge of ROM bin appears to be a viable option.

table 2 Dust collection summary

Dust collection For exit through 20cm holes in the bin	Dust released from the bottom of the bin Kg/sec	Dust collected Kg/sec	Remarks
Empty bin	1.67	0.84	50% dust is extracted, the rest is contained within the bin and doesn't flow out of the bin.
Half-empty bin	1.67	1.01	60% dust is extracted, the rest is contained within the bin and doesn't flow out of the bin.
Full bin	1.67	1.1	65% dust is extracted, the rest is contained within the bin and doesn't flow out of the bin.

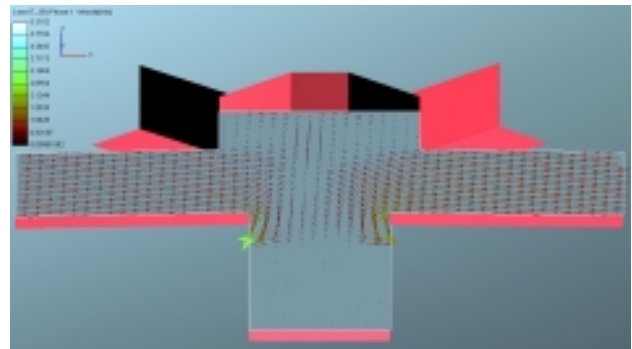

Fig. 4 Velocity vectors on a vertical plane through the centre of Tunnel 1 & 4, (empty bin scenario)

## Velocity and Dust Concentration

The velocity vectors on a vertical plane through the centre of Tunnels 1 & 4, (Fig. 4) clearly show that, at the entrance to the tipple, the flow bifurcates, with the majority of the flow bending downwards towards the exit holes and a small portion bending upward forming two vortices near the ceiling. This upward stream has the potential to carry the dust, which may come from tunnel, to the two vortices near the ceiling and form dust cloud. The velocity magnitudes in bin, below the exit-hole level, were very small.

The volume flow rate through tunnel-2 is very small (see table 1). The velocity vectors in Fig. 5 show that the flow doesn't have enough momentum to penetrate into the tipple and is quickly sucked in towards the exit holes. The volume flow rate through tunnel-3 is also relatively low (see table 1) and is also quickly sucked in towards the exit holes Fig. 6. Flows coming through tunnels 3 & 4 doesn't show the tendency of bifurcation observed in those of tunnel 1 & 4 (Fig.4). It may be possible to remove the formation of vortices near the ceiling and hence the potential of

dust cloud formation there by adjusting/balancing the flow rates through the tunnels.

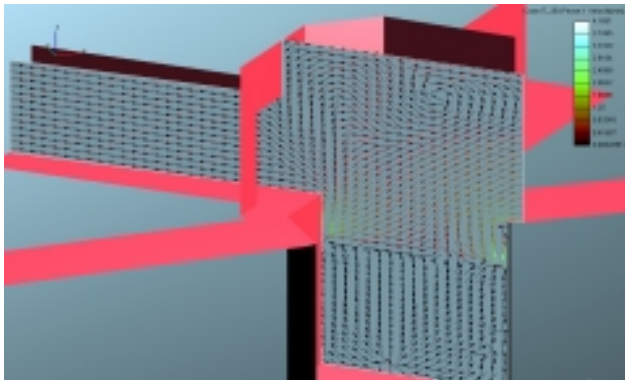

Fig. 5 Velocity vectors on a vertical plane through the centre of Tunnel 2 (empty bin scenario)

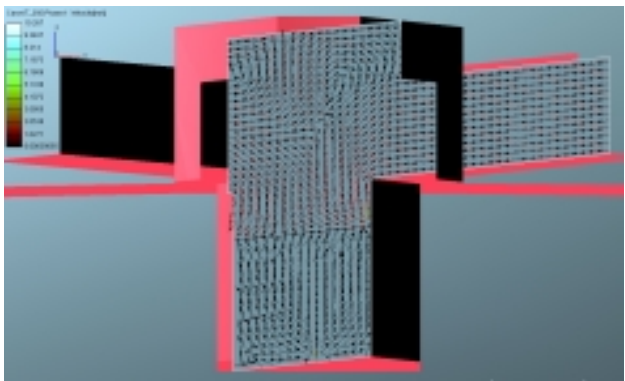

Fig. 6 Velocity vectors on a vertical plane through the centre of Tunnel 3 (empty bin scenario)

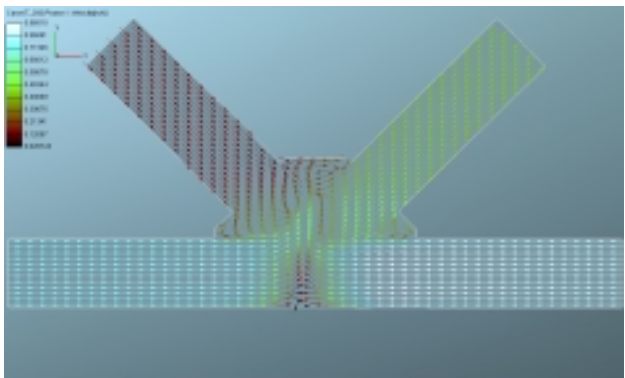

Fig. 7 Velocity vectors on a horizontal plane through the centre of Tunnels (empty bin scenario)

Velocity vectors on a horizontal plane through the centre of tunnels (Fig. 7) show that the higher flow rates through tunnels-1 & 4 leads to greater penetration into the tipple, whereas the least flow rate through tunnel-2 leads to lowest penetration.

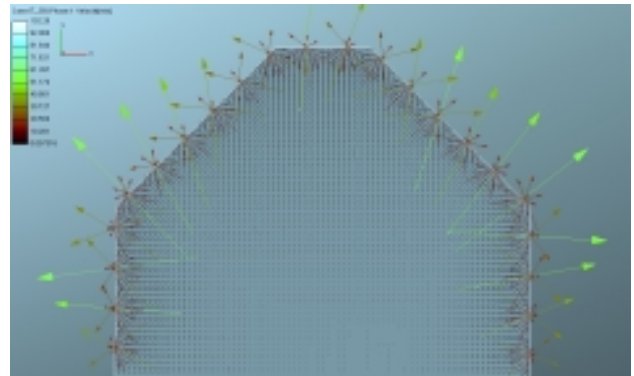

Fig. 8 Velocity vectors on a horizontal plane through 20cm holes in the bin (empty bin scenario)

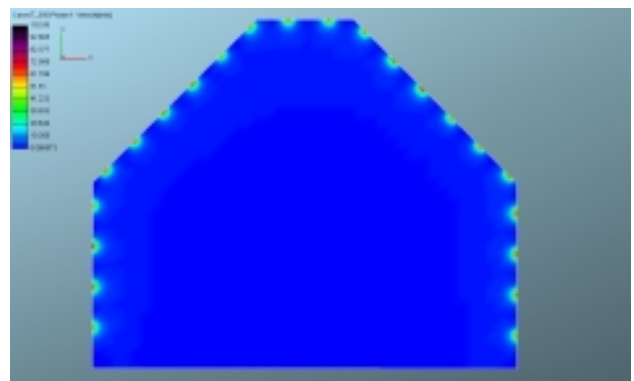

Fig. 9 Velocity contours on a horizontal plane through 20cm holes in the bin (empty bin scenario)

Velocity vectors and contours (Figs. 8 & 9) on a horizontal plane through 20cm holes in the bin clearly show that the velocity magnitudes are very high in and around the holes and reach a maximum of 102m/s. This high velocity (which is in the compressible flow regime) may lead to high pressure drop and generation of noise. Efforts may be made to reduce these high velocities by using bigger whole diameters.



Fig. 10 Dust iso-contours or iso-surface ( $100\text{mg}/\text{m}^3$ ) (empty bin scenario) (A snap shot of transient/time dependent case)



Fig. 11 Dust iso-contours or iso-surface ( $100\text{mg}/\text{m}^3$ ) (empty bin scenario) (steady state case)

Dust iso-contours or iso-surface ( $100\text{mg}/\text{m}^3$ ) are presented in Figs. 10 & 11. It may be mentioned here that the dust concentration inside the iso-surface envelope is greater than  $100\text{mg}/\text{m}^3$ . It is encouraging to see that the dust is well contained within the bin. However, the dust generated by the movement of LHD in the tunnels is ignored in this study. The dust generated by LHD movement and the pattern of flow coming into the tipple through tunnels-1 & 4 (Fig 4a) has the potential to form dust cloud near the ceiling. This can be investigated as an extension of this study.

The results for half-empty and full bin scenarios, not presented in this paper, show very similar behaviour to that observed for empty bin scenario presented above. However, for the benefit of the readers, dust iso-contours ( $100\text{mg}/\text{m}^3$ ) for full bin scenarios, are presented in Figs. 13 & 14. Again, dust appears to be contained within the bin for both the transient and steady state simulations for the full bin case.



Fig. 13 Dust iso-contours or iso-surface ( $100\text{mg}/\text{m}^3$ ) (full bin scenario) (A snap shot of transient/time dependent case)



Fig. 14 Dust iso-contours or iso-surface ( $100\text{mg}/\text{m}^3$ ) (full bin scenario) (steady state case)

### Conclusions

Dust collection through the holes along the top edge of ROM bin appears to be a viable option for collecting dust from an underground crushing plant. Under the conditions and assumptions made of the present study, dust released from the bin was found to be contained within the bin. The dust generated by the movement of loading trucks in the tunnels was ignored in this study. This can be investigated as an extension of this study. Efforts may also be made to reduce the high velocities observed in the bin holes by using bigger diameter holes.

### References

- [1] Johansen, S.T., & Laux, H., Simulation of granular flows, Proceedings of RELPOWFLO III, *The international symposium on the reliable flow of particulate solids*, Telemark College, Porsgrunn, Norway, 11-13 August 1999
- [2] Silvester, S.A., Lowndes, I.S., Kingman, S.W., The ventilation of an underground crushing plant, *Mining Technology*, Dec. 2004, Vol.113
- [3] FIRE, *user guide*, [www.avl.com](http://www.avl.com)