

Life Cycle Evolution in the Digenea: a New Perspective from Phylogeny

Thomas H. Cribb¹, Rodney A. Bray², Peter D. Olson²,
D. Timothy J. Littlewood²

¹*Department of Microbiology & Parasitology and Centre for Marine Studies,
The University of Queensland, Brisbane, 4072 Australia*

²*Parasitic Worms Division, Department of Zoology, The Natural
History Museum, Cromwell Road, London SW7 5BD, UK*

Abstract	198
1. Introduction	198
2. Methods	199
2.1. The Tree	200
2.2. The Life Cycle Database	200
2.3. Mapping Life Cycle Characters	202
3. Background to the Digenea	203
3.1. Relationships within the Neodermata	203
3.2. The Digenea in Outline	204
3.3. Aspidogastrea – The Sister Group to the Digenea	206
3.4. A New Phylogeny of the Trematoda	207
4. Mapping and Interpreting Life Cycle Traits	209
4.1. First Intermediate Hosts	209
4.2. Second Intermediate Hosts	214
4.3. Definitive Hosts	217
4.4. Infection Processes – Miracidial Behaviour	220
4.5. Rediae and Sporocysts	220
4.6. Cercarial Tails	223
4.7. Infection Processes – Cercarial Behaviour	224
4.8. A Hypothesis of Evolution within the Plagiorchiida	227
4.9. Hypotheses of Evolution within the Diplostomida	234
5. Problems	240
5.1. Shortcomings of the Parsimony Approach	240
5.2. Conflict between Hypotheses	241
5.3. Ten Questions	243

ADVANCES IN PARASITOLOGY VOL 54
0065-308X \$35.00

Copyright © 2003 Elsevier Ltd
All rights of reproduction in any form reserved

0065-308X(200304)54:1;1-0

under a CC BY-NC-ND 4.0 International license

On

12 APR 2006

Appendix	244
Order Diplostomida	244
Order Plagiorchiida	245
Acknowledgements	249
References	249

ABSTRACT

We use a new molecular phylogeny, developed from small and large subunit ribosomal RNA genes, to explore evolution of the digenean life cycle. Our approach is to map character states on the phylogeny and then use parsimony to infer how the character evolved. We conclude that, plesiomorphically, digenean miracidia hatched from eggs and penetrated gastropod first intermediate hosts externally. Fork-tailed cercariae were produced in rediae and emerged from the snail to be eaten directly by the teleost definitive host. These plesiomorphic characters are seen in extant Bivesiculidae. We infer that external encystment and the use of second intermediate hosts are derived from this behaviour and that second intermediate hosts have been adopted repeatedly. Tetrapod definitive hosts have also been adopted repeatedly. The new phylogeny proposes a basal dichotomy between 'Diplostomida' (Diplostomoidea, Schistosomatoidea and Brachylaimoidea) and 'Plagiorchiida' (all other digeneans). There is no evidence for coevolution between these clades and groups of gastropods. The most primitive life cycles are seen in basal Plagiorchiida. Basal Diplostomida have three-host life cycles and are associated with tetrapods. The blood flukes (Schistosomatoidea) are inferred to have derived their two-host life cycles by abbreviating three-host cycles. Diplostomida have no adult stages in fishes except by life cycle abbreviation. We present and test a radical hypothesis that the blood-fluke cycle is plesiomorphic within the Diplostomida.

1. INTRODUCTION

The Digenea is one of two subclasses of the Trematoda that, together with the classes Cestoda and Monogenea, form the Neodermata within the phylum Platyhelminthes. These three classes of flatworms are entirely parasitic. Of the three, the Digenea, or flukes, have the most complex life cycles by far. They may have from one to four hosts, three distinct

generations, many morphologically distinct forms, and they infect their hosts in many different ways. This complexity has been of interest to helminthologists from the moment their life cycles began to be elucidated. Two main classes of questions have been explored: How did the complex digenean life cycle as a whole arise? and How has the variation within the group evolved? By no means has a consensus emerged that answers either question satisfactorily. Indeed, even where consensus appears to have been reached on a particular point, the explanation is not necessarily well founded.

Until convincing phylogenetic hypotheses began to be published in the 1980s for the Platyhelminthes as a whole and the Digenea in particular, attempts to understand the evolution of life cycles within the phylum were seriously hampered. Hypotheses could only be developed as plausible narratives that accounted for what was known of the biology of the animals. The lack of methodological rigour inherent in the narrative approach meant that there were no real means of testing these hypotheses objectively. Despite this, earlier authors made remarkable progress; the ideas of Pearson (1972; 1992), Rohde (1972), Cable (1974; 1982), Gibson (1987) and many others summarised by these authors remain highly influential and often intuitively persuasive. If an advance in understanding is taking place (certainly no one would contend that the debates are concluded), then it is by the application of phylogenetic systematics and molecular data sets that allow the old ideas, and many new ones, to be tested with greater objectivity than was possible previously. Our goal here is to understand the origins and evolution of the digenean life cycle by examining its variation in the light of a phylogeny derived wholly independently of the life cycle characters themselves.

2. METHODS

Our inferences are based entirely on the phylogeny of the Digenea as inferred from an independent, molecular data set (Olson *et al.*, 2003); not on a tree derived from the life cycle characters we examine herein, or any other combination of morphological characters. We make no assumptions *a priori* about character polarity, for example, but instead allow the positions of the taxa exhibiting the characters themselves to determine which states are plesiomorphic and which are derived. It is implicit then that we accept the hypothesis presented in Olson *et al.* (2003), and the classification that follows from it, as the basis for all inferences made herein. Although the character state patterns we discuss are sometimes complicated or equivocal and thus require considerable discussion, there is no special

pleading for a particular pattern by reference to other factors that may argue for one course of evolution over another; in all cases, the molecular-based phylogeny is the final arbitrator.

2.1. The Tree

The phylogeny of the Digenea (Olson *et al.*, 2003) was based on a Bayesian analysis (Huelsenbeck *et al.*, 2001) of 170 taxa characterized for both the large (variable domains D1–D3) and small (complete) subunit nuclear ribosomal genes giving a total of 2648 alignable positions. This constitutes by far the largest molecular-based hypothesis for the group to date and includes considerable representation of their diversity among marine and freshwater teleosts, elasmobranchs, and tetrapod hosts. In addition, seven species representing seven different aspidogastrean genera were used to root the tree. Although multiple hypotheses based on different analyses are presented in their paper (Olson *et al.*, 2003), the Bayesian analysis including all taxa and all characters is reproduced here (Figure 1). The same figure was used as the basis for a discussion and revision of digenean classification. Their classification amends and expands that proposed in volume one of *Keys to the Trematoda* (Gibson *et al.*, 2002) and forthcoming volumes, and includes a number of new higher-taxon names, altered memberships, and other systematic changes that the non-specialist is likely to be unfamiliar with. For example, we do not recognize the traditional orders Echinostomida and Strigeida. Instead, a basal dichotomy is proposed, separating the Diplostomida (comprised of only, but not including all, 'strigeids') and the Plagiorchiida (in which 'echinostomids', 'plagiorchiids', and the remaining 'strigeids' are inter-mixed). Smaller clades are recognized as suborders, superfamilies, and so on. *Keys to the Trematoda* (Gibson *et al.*, 2002) provide a revised classification only to the level of superfamily and, generally speaking, the superfamilial circumscriptions based on morphology (Gibson *et al.*, 2002) and those based on molecules (Olson *et al.*, 2003) are in agreement. Section 3.4 includes a more detailed discussion on the tree and the classification.

2.2. The Life Cycle Database

Life cycle trait character states are derived from a database of life cycles for the Digenea that we have compiled. This database currently comprises published information on approximately 1350 species (including many

cercariae which have not been associated with sexual adults) and compiles information on the identity of hosts and the behaviour and morphology of the life cycle stages. There is such great variability within life cycles of the Digenea that we have been forced in some cases to make assumptions when comparing states for higher taxa (e.g. families and superfamilies). For example, life cycles of some opecoelids, where an arthropod is the definitive host, are disregarded as we conclude that they have evolved by abbreviation of the life cycle (Poulin and Cribb, 2002). In most cases such exceptions are mentioned in the text but, when this is not so, we have striven to assume nothing that has been open to serious challenge. The literature is now very large and we are likely to have missed several significant studies. We have, however, endeavoured to compile a complete listing.

2.3. Mapping Life Cycle Characters

We infer the evolution of individual life cycle traits by examining their distribution on the phylogenetic tree. For character mapping we follow the methods outlined by Maddison and Maddison (2000) in the MacClade manual, and we encourage readers unfamiliar with this topic to start with their review. We paraphrase the basic principles here. Put simply, we pursue the following general question: given the topology of the phylogenetic tree, the states observed in the terminal taxa, and the assumptions (if any) regarding character evolution, what assignments of states to the internal nodes of the tree require the fewest evolutionary steps? When all extant members of one clade share character state 1, then it is simplest to infer that all the ancestral members of the clade also had state 1. Of course, it may be more complex than this, and although many algorithms for character mapping have been developed incorporating various nuances in the way characters are allowed to evolve, we have used a manual approach throughout, deducing plesiomorphic (ancestral) character states whenever possible. We have few preconceived ideas of how life cycle characters may evolve from one state to another, and such characters are undoubtedly difficult to homologize. For instance, we do not know if losing a host is as easy as acquiring one and whether the definitive host in a two-host life cycle is homologous with the definitive host in a three-host life-cycle. Thus, we have not weighted or dictated the direction of character state transformations. The acquisitions of a host, the appearance of an attachment organ or the development of a behavioural strategy are all life cycle characters worthy of mapping, but clearly they are not of equal rank. Indeed, the problem in employing phylogenies in

understanding behaviours is a discipline unto itself (Martins, 1996). We do not have an explicit matrix of characters to hand that lends itself to a character mapping program such as MacClade. Instead, we make use of a growing descriptive database.

3. BACKGROUND TO THE DIGENEA

Understanding evolution of life cycle traits in the Digenea requires an understanding of the relationships in the Neodermata as a whole, the nature of the Digenea itself (especially its life cycle), the nature of the sister-group to the Digenea (the Aspidogastrea), and relationships within the Digenea. We briefly review these subjects below.

3.1. Relationships within the Neodermata

It is now well accepted that the Class Trematoda forms part of a clade of completely parasitic platyhelminths, the Neodermata, together with the Cestoda and the Monogenea. The Neodermata is separated from a myriad of turbellarian taxa by combinations of morphological and molecular characters (Littlewood *et al.*, 1999). The Neodermata thus encompasses all major platyhelminth taxa that parasitize vertebrates.

The higher classification and basic phylogenetic relationships of the Neodermata are considered broadly resolved by most authors. The system is simple. The Class Trematoda forms the sister taxon to the Cercomeromorpha which is composed of the Monogenea, Gyrocotylidea, Amphilinidea and Eucestoda (Figure 2). Lockyer *et al.* (2003) have new analyses that challenge the cercomeromorph theory and suggest that the Cestoda (= Gyrocotylidea + Amphilinidea + Eucestoda) may be the sister taxon to the Trematoda. Surprisingly, this controversial hypothesis has little effect on the analysis presented below and it is thus not considered further here.

The topology of the relationships of the Neodermata provides a simple example of the mapping and interpretation of life cycle traits. The parsimonious hypothesis for the adoption of these hosts is shown in Figure 2. It can be inferred that the Neodermata as a whole adopted vertebrate parasitism, that the Trematoda subsequently adopted parasitism of molluscs as intermediate hosts, and that the Eucestoda + Amphilinidea adopted parasitism of crustacean intermediate hosts. This inference was first made by Littlewood *et al.* (1999).

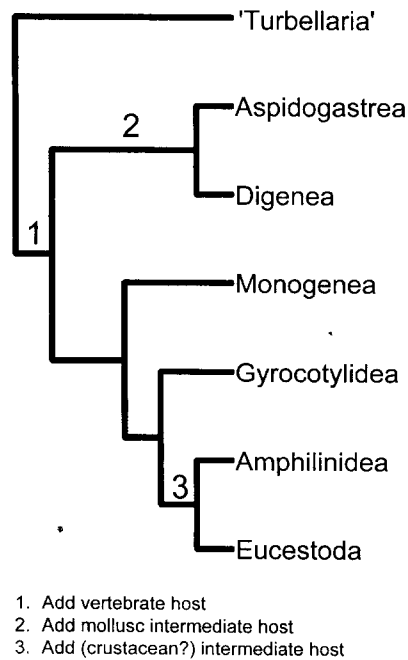

Figure 2. Phylogeny of the Neodermata and a parsimonious hypothesis for the adoption of definitive host groups.

3.2. The Digenea in Outline

The Digenea are one of the most successful groups of parasitic flatworms. Digeneans occur in significant numbers in all classes of vertebrates, although they are surprisingly rare in chondrichthyans, in which cestodes and monogeneans are the dominant platyhelminths (see Bray and Cribb, 2003). As adults they are primarily parasites of the intestine, but representatives are also found in fish under the scales, on the gills, in the swim bladder, in the body cavity, the urinary bladder, the gall bladder, in the flesh, connective tissue, ovary and in the circulatory system. In tetrapods, they may also be found in extra-intestinal sites including the circulatory system, lungs, air sacs, oesophagus, urinary bladder, liver, eye and ovary. Morphological variation is found in the form and position of the suckers, the digestive tract and the reproductive system. Despite this variation, the sexual adults of phylogenetically distinct taxa may resemble each other closely (e.g. *Allocreadiidae* and *Opecoelidae*, *Heterophyidae* and *Microphallidae*), whereas their life cycle stages are obviously different.

The digenean life cycle usually involves both free-living and parasitic stages and always incorporates both asexual and sexual multiplication. Most cycles are at least partially aquatic and alternate between a mollusc and a vertebrate. Sexual adults occur in any of the sites mentioned above where they produce eggs that pass to the external environment. These eggs typically hatch to release a motile, short-lived, non-feeding, ciliated larva, the miracidium. The miracidium swims and penetrates a molluscan intermediate host in which it sheds its ciliated outer cells and develops into a mother sporocyst. The mother sporocyst is a simple sac that lacks any trace of feeding structures or gonads. It produces a second intra-molluscan generation asexually. This generation comprises either multiple daughter sporocysts or rediae. Daughter sporocysts resemble the mother sporocyst, whereas rediae have a mouth, a pharynx and a short saccular gut. In the case of both second intra-molluscan generation types, i.e., daughter sporocysts and rediae, there is another round of asexual reproduction. In this case, the progeny are usually cercariae, the larvae of the generation that will ultimately become the sexual adult. The cercaria is usually a tailed form that emerges actively from the mollusc. After emergence, the cercaria behaves in one of several distinct ways that ultimately leads to active or passive infection of the vertebrate definitive host. Often the vertebrate is infected by ingestion of a metacercaria associated with a second intermediate host.

Significant departures from the developmental pattern described above are numerous. In many digenean taxa (e.g. the superfamilies Brachylaimoidea, Hemiuroidea, Opisthorchioidea, Pronocephaloidea), the molluscan host eats the egg and is then penetrated internally. In the Pronocephaloidea, this process is specialized to the point of a process of mechanical injection (Murrills *et al.*, 1985). The interaction between the intra-molluscan generations may be complex. In some families (e.g. Heronimidae and Bucephalidae), it is possible that there is only a mother sporocyst. Beyond this, the distinction between daughter sporocysts and rediae is not as clear as often thought. In some life cycles, rediae have been shown to lose their digestive systems during ontogeny so as to become sporocysts secondarily. Some authors have considered daughter sporocysts as paedogenetic rediae (Matthews, B.F. 1980). In addition, the progression between the intra-molluscan generations described above may not be as simple as outlined. There are many reports of rediae or sporocysts producing more rediae or sporocysts as well as cercariae. This plasticity in the life cycle was demonstrated most dramatically by Dönges (1971), who showed that cercaria-producing rediae of echinostomatids were always capable of reverting to the production of rediae if they were transplanted to an uninfected gastropod. Finally, life cycles of some cyathocotylids have been described in which sporocysts have been found to produce miracidia

that emerge from the snail (Sewell, 1922; Barker and Cribb, 1993), presumably to infect other snails. The evolution of such complexity and variation has been fertile ground for more than a century of conjecture and debate.

3.3. Aspidogastrea – The Sister Group to the Digenea

The Trematoda comprises two subclasses – the Aspidogastrea and the Digenea. The Aspidogastrea comprises just four families and perhaps 80 species (Rohde, 2001) in contrast to well over 100 families and certainly over 10,000 species of digeneans (Gibson *et al.*, 2002). Many authors, including Rohde (2001), have considered the Aspidogastrea to be 'archaic' relatives of the Digenea because of the relative simplicity of their life cycles compared to those of digeneans. As they are the sister group to the Digenea, it is necessary to have a basic understanding of their life cycles.

Of the four families (Aspidogastridae, Multicalycidae, Rugogastridae and Stichocotylidae), complete life cycles are known only for the Aspidogastridae. This, by far the largest family, occurs as sexual adults in molluscs, teleosts and turtles. Sexual adults typically live in the intestine of vertebrates and pass eggs in the faeces. These hatch to liberate a ciliated cotylocidium that swims to a molluscan host to which it attaches. The cotylocidium sheds its cilia and develops directly to an infective stage in which the characteristic loculated ventral sucker has formed something resembling its final condition. Parasitism of the mollusc is usually by attachment to its external surfaces, for example within the mantle cavity (Ferguson *et al.*, 1999). In a number of cases, however (see summary by Rohde, 1972), the parasite enters pores of the molluscs and may be found in the pericardial cavity, kidney cavity, and even inside the gill filaments. The vertebrate is always infected by ingestion of the mollusc.

There are two significant variations on this pattern. The first was described for *Lobatostoma manteri* (Rohde, 1973, 1975; Rohde and Sandland, 1973). In this cycle, the egg does not hatch until the gastropod host eats it. It then hatches within the mollusc gut and migrates into the cavity of the digestive gland of the gastropod, where it develops to a juvenile; the life cycle is again completed by the ingestion of the mollusc. The juvenile is in the gut, not within the tissues as apparently always occurs in the infections of digeneans within molluscs. The second significant variation is that several aspidogastrids develop to sexual maturity on their molluscan hosts. In some life cycles, the vertebrate host is thus facultative and, in a few species, there is no known vertebrate host. The life cycles of the other families are not well known but there is no indication of

significant differences except that the sole stichocotyloid, *Stichocotyle nephropis*, occurs as juveniles encapsulated in the crustacean *Nephrops* which presumably acts as a second intermediate host since the final hosts are rays (*Raja clavata*).

Key features of the Aspidogastrea relative to the Digenea are that they are external rather than visceral parasites of molluscs, lack asexual reproduction entirely, and have no stage comparable to the cercaria. Thus, although certainly the sister-taxon to the Digenea, the aspidogastreaean life cycle is so different from that of digeneans that it may offer little insight into the evolution of the digenean life cycle.

3.4. A New Phylogeny of the Trematoda

The phylogeny of the Trematoda used here (Figure 1) is that of (Olson *et al.*, 2003), which includes a revised classification of the group (their Figure 6). This phylogeny is based on complete small subunit rDNA and partial (D1–D3) large subunit rDNA sequences of 170 taxa from 77 nominal families. This is the largest set of taxa and characters yet assembled for the Digenea and therefore may be more reliable and informative than previous analyses. The phylogeny used in the present analyses, and on which the classification of Olson *et al.* (2003) is based, is based on Bayesian inference from both the large and small nuclear ribosomal genes (their Figure 3).

Perhaps the key feature of the phylogeny and classification of Olson *et al.* (2003) is its recognition of a clear basal dichotomy between two superorders named the Diplostomida (new name) and the Plagiorchiida; there is no small basal taxon although the Plagiorchiida is far larger than the Diplostomida. Fourteen orders (eight new) are recognized within the superorders. All Diplostomida are incorporated in three superfamilies in the Order Diplostomata. Of the thirteen orders recognized within the Plagiorchiida, nine contain only single superfamilies. The four more inclusive orders are the Hemiurata (Azygioidea + Hemiuroidea), Bucephalata (Bucephaloidea + Gymnophalloidea), Paramphistomata (Paramphistomoidea + Pronocephaloidea) and Xiphidiata (Gorgoderoidea + Microphalloidea + Allocreadioidea + Plagiorchioidea). The superorders, orders and superfamilies are the primary groups that we have used for considering life cycle evolution, although the trees show the superfamily Schistosomatoidea divided into its four constituent families, the Clinostomidae, Sanguinicolidae, Schistosomatidae and Spirorchidae. This is done partly because this superfamily is so complex and interesting, and partly because it is paraphyletic with respect to the three blood-dwelling groups. In referring to digenean taxa we refer to the most inclusive taxon

available. Thus, lists of taxa that share a particular character might include families, superfamilies and orders. Where an order contains just one superfamily we refer to the superfamily.

The number of taxa incorporated in the trees used has been reduced as far as possible for simplicity. For example, multiple taxa from the Cryptogonimidae, Heterophyidae and Opisthorchiidae are always represented by a single higher taxon, the Opisthorchioidea. This reflects the fact that, for the purposes of the present analysis, there is no known difference in the life cycles represented in this superfamily. A brief description of the key life cycle characteristics found in each of the 22 superfamilies recognized by Olson *et al.* (2003) is given in the Appendix. The complete phylogeny and higher classification referred to in this analysis is shown in Figure 3. Two

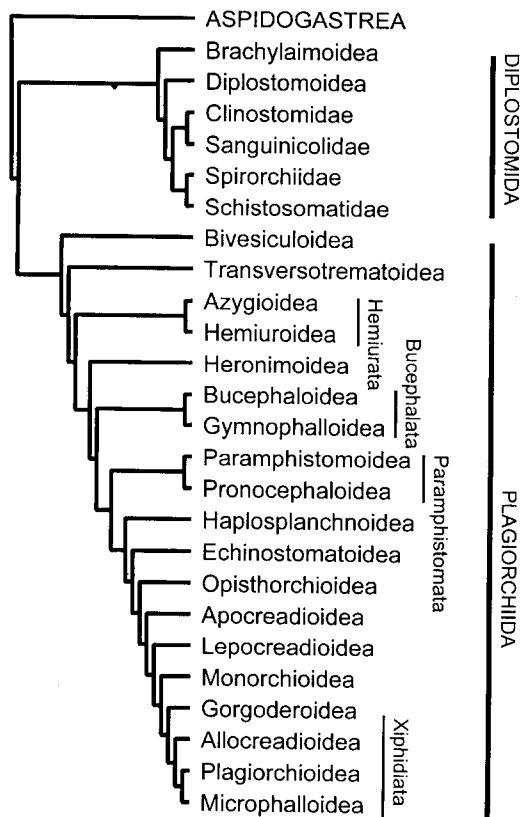

Figure 3 Relationships and higher classification of the superfamilies of the Digenea (based on Olson *et al.*, 2003) used in this analysis.

key elements of the classification remain unconfirmed. The type families of the Allocreadioidea and the Gymnophalloidea were not included in the molecular analyses, and so the composition of these superfamilies is partly speculative; see Olson *et al.* (2003) for a complete list of exemplar taxa analysed.

Readers should be aware that some elements of the classification proposed by Olson *et al.* (2003) and used here conflict with that proposed in volume one of *Keys to the Trematoda* (Gibson *et al.*, 2002) and subsequent volumes. For example, we recognise the Clinostomidae as part of the Schistosomatoidea which invalidates the Clinostomoidea as recognised by Kanev *et al.* (2002) to include the Clinostomidae and Liolopidae. This change was necessitated by the close relationship identified between the Clinostomidae and the Sanguinicolidae. We see this change as an example of the fact that the classification of the Digenea is presently evolving quite rapidly. We gladly acknowledge, however, that all aspects of the classification remain hypotheses. Certainly the changes that we propose in no way affect the utility of *Keys to the Trematoda* in facilitating the identification of digeneans.

4. MAPPING AND INTERPRETING LIFE CYCLE TRAITS

The variety in the life cycle of digeneans is reduced here to distinctions in the identity of the hosts (first intermediate, second intermediate, definitive), the processes that lead to the infection of these hosts, and the morphology of the life cycle stages. It is unclear, at least *a priori*, to what extent these characters are connected. Our approach, therefore, is to derive hypotheses for these traits independently and then attempt to draw the separate hypotheses together.

4.1. First Intermediate Hosts

Figure 4 shows the distribution of the four major groups of first intermediate hosts: gastropods, bivalves, scaphopods and polychaetes. Gastropods are clearly the most common group. However, common does not necessarily equate with primitive; therefore it is necessary to analyse the data with respect to phylogeny. The outgroup, the Aspidogastrea, infect bivalves and gastropods. This allows four interpretations of the original molluscan hosts of trematodes: (a) gastropods were the basal host group; (b) bivalves were the basal host group; (c) the group as a whole coevolved with

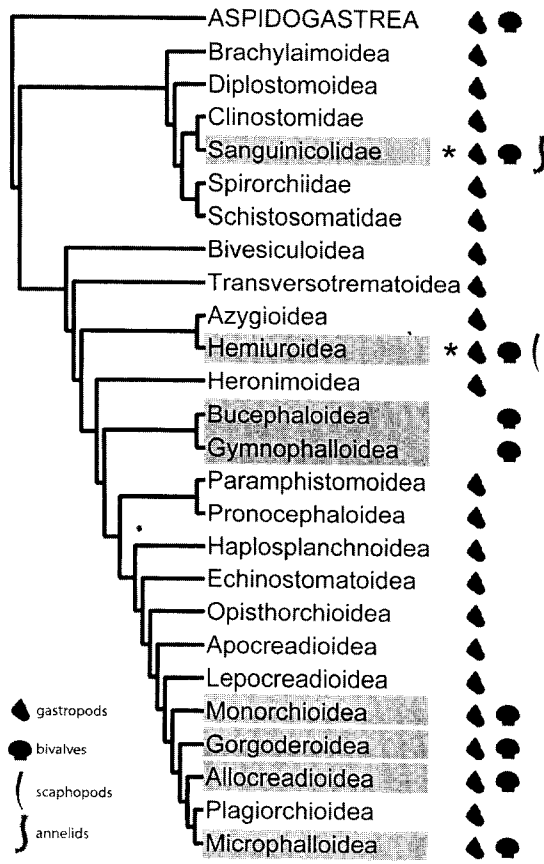

Figure 4 Digenean life cycle variation – first intermediate hosts (gastropods, bivalves, scaphopods and annelids). Shaded taxa are inferred to have host-switched from gastropods. Taxa marked with an asterisk (*) are inferred to have made two switches.

molluscs as a whole; and (d) the infection of molluscs by aspidogastreae and digeneans arose independently. We first reject (d) because the Trematoda as a whole appear to be defined in part by their shared parasitism of molluscs. We reject (c) because the association of trematodes with the other classes of molluscs is either very rare (Scaphopoda) or unknown (Aplacophora, Polyplacophora, Cephalopoda). We can distinguish between (a) and (b) comparing the number of evolutionary changes that each hypothesis requires.

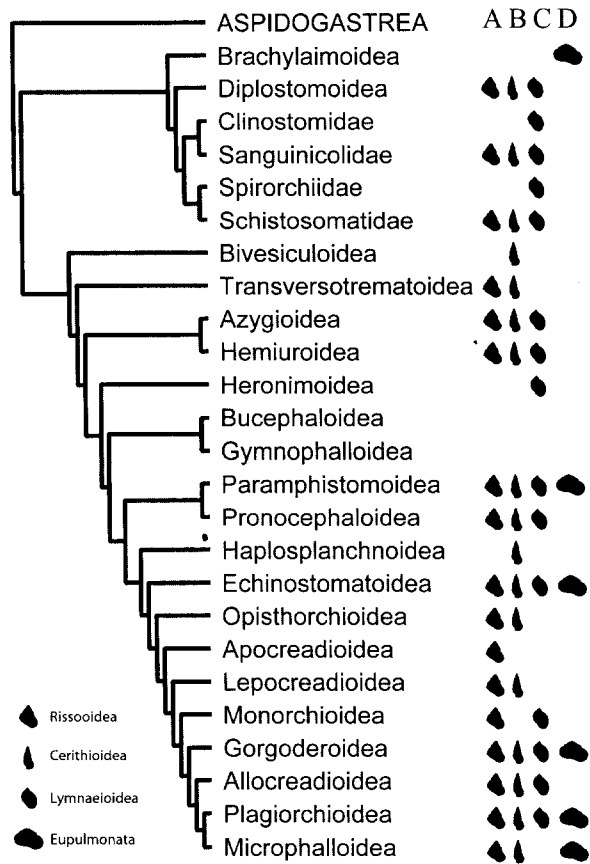

Figure 5 Digenean life cycle variation – first intermediate hosts – selected gastropod taxa. A, Rissooidea; B, Cerithioidea; C, Lymnaeioidea; D, Eupulmonata. Intermediate hosts of Aspidogastrea are not shown.

If the original host of trematodes was a bivalve, then the parasitism of gastropods, polychaetes and scaphopods shown in Figure 4 requires 24 changes of host (if no reversal of host is allowed). If reversals are allowed, then the host distribution can be explained in eleven steps. In contrast, if the gastropods were the first host group then the host distribution can be explained in just ten steps of host change and no host reversal need be invoked. The eight taxa in which such changes are hypothesized to have occurred are highlighted on Figure 4 and the two in which at least two host changes are necessary are further marked with an asterisk. Hypotheses that

polychaetes or scaphopods were the first hosts are even less parsimonious. We thus conclude that gastropods were the basal host group for the Digenea.

We are also interested in the detail of the individual host associations. Scaphopods are known hosts only for a Ptychogonimid (Palombi, 1942) (the family presently has only two species) and for one Lecithasterid hemiuroid (Køie *et al.*, 2002), whereas other Lecithasterids use gastropods exclusively. The family Ptychogonimidae is of interest in this respect as it is likely to be one of the most basal taxa in the Hemiuroidea; unfortunately, this family was not represented in the present phylogeny. The Lecithasteridae is relatively derived within the Hemiuroidea. Polychaetes are even more restricted, occurring as hosts only for some sanguinicolids. Thus, the conclusion that scaphopods and polychaetes were acquired by host-switching is plausible as well as parsimonious. Remarkably, sanguinicolids are found in significant numbers in gastropods, bivalves and polychaetes as first intermediate hosts, but not enough is known about relationships within the Sanguinicolidae or about the life cycles of marine taxa for us to draw conclusions on the origins of this diversity.

Although the majority of digeneans infect gastropods, bivalves nevertheless form a significant intermediate host group (Figure 4). In the Diplostomida, bivalves are hosts only rarely (some sanguinicolids), but in the Plagiorchiida they are host to the Allocreadiidae, Bucephalata, Faustulidae, Gorgoderidae and Monorchiidae. The topology of relationships within the Digenea suggests that, as proposed by Hall *et al.* (1999) and others, parasitism of bivalves has arisen as the result of host-switching from gastropods and that it arose at least seven times (this inference assumes that the Allocreadiidae does indeed form a clade with the Opecoelidae, Brachycladiidae and Acanthocolpidae as predicted by Olson *et al.*, 2003). The Bucephalata is by far the largest taxon that is restricted to bivalves as first intermediate hosts; no other whole superfamily is found only in bivalves.

If it is accepted that bivalves, scaphopods and polychaetes are infected as the result of host-switching from gastropods, then it is still possible that those taxa associated with gastropods will show evidence of host-parasite coevolution via congruence of the host and parasite phylogenies. However, the evidence is strongly against such an interpretation. The simplest level of phylogenetic comparison possible is that between the Diplostomida and the Plagiorchiida, the two primary clades of digeneans. About 23% of records of first intermediate hosts in our database relate to the Diplostomida and the remainder to the Plagiorchiida. Few distinctions are noticeable in the distribution of the gastropods they infect (Table 1). For both groups, there are substantial numbers of records from

Table 1 Major gastropod taxa as first intermediate hosts of Diplostomida and Plagiorchiida.

Subclass	Order	Superfamily	Diplostomida	Plagiorchiida
Eogastropoda	Patellogastropoda	Acmaeoidea		•
		Patelloidea		•
Opisthobranchia	Cephalaspidea	Haminoeidea	•	
		Philinoidea		•
Orthogastropoda		Ampullarioidea	•	•
		Calyptraeoidea		•
		Cerithioidea	•	•
		Conoidea		•
		Fissurelloidea		•
		Littorinoidea	•	•
		Muricoidea	•	•
		Naticoidea		•
		Neritoidea	•	•
		Pyramidelloidea		•
		Rissooidea	•	•
		Trochoidea		•
		Valvatoidea	•	•
		Velutinoidea		•
Pulmonata	Basommatophora	Amphiboloidea		•
		Lymnaeoidea	•	•
		Siphonarioidea		•
	Eupulmonata	Achatinoidea	•	•
		Arionoidea	•	
		Helicoidea	•	•
		Limacoidea	•	•
		Partuloidea		•
		Polygyroidea	•	•
		Pupilloidea	•	•
		Rhytidoidea	•	
		Succineoidea	•	•

"prosobranchs" (especially Rissooidea and Cerithioidea) and freshwater pulmonates (especially Lymnaeoidea), and the terrestrial pulmonates (Eupulmonata) used by the two groups are also similar. The distributions of these four gastropod taxa are shown in Figure 5, where they are scattered throughout the phylogeny. Thus, we find no reflection of the basal dichotomy of the Digenea in the first intermediate hosts. The

implication of this is that there has been no deep level coevolution between the major clades of digeneans and their molluscan hosts or, if it has occurred, it is rendered unrecognizable by host-switching. If such coevolution has occurred at all it may have been within smaller clades. The Hemiuroidea, Sanguinicolidae and Bucephalidae each have a wide range of intermediate hosts and the possibility that they coevolved with their hosts has not yet been explored.

4.2. Second Intermediate Hosts

At least 17 of the 22 digenean superfamilies incorporate second intermediate hosts in their life cycles. Figure 6 shows the distribution of taxa exploited as second intermediate hosts. Table 2 shows counts for host phyla extracted from our database. Two features are immediately striking. There is a great diversity of intermediate hosts (nine phyla) and the distributions of different types of hosts are discontinuous on the phylogeny. These observations lead to the conclusion that three-host life cycles have been adopted repeatedly. The fact that three of the most basal superfamilies (Bivesiculoidea, Azygioidea and Transversotrematoidea) usually lack second intermediate hosts indicates that three-host cycles have been derived from two-host forms. Outgroup comparison with the Aspidogastrea also indicates that a two-host life cycle was plesiomorphic for the Digenea. We can conclude that at least the Diplostomida, Hemiuroidea, Bucephalata and the Echinostomatoidea, plus all remaining Plagiorchiida, must each have separately adopted second intermediate hosts.

An important component of the adoption of second intermediate hosts is the identity of host groups. Most clades have distinctive host distributions and several show perfect or almost perfect fealty to a single host group. Thus, the Azygioidea, Bucephaloidea, Opisthorchioidea and the majority of Diplostomoidea are restricted to vertebrates and the Brachylaimoidea are entirely restricted to molluscs. As each taxon with this restricted relationship with a group of second intermediate hosts is isolated from any other taxon solely using the same host group, it is arguable that each represents either an independent adoption or involved a complete switch of host group. Cribb *et al.* (2002) suggested that it was a hallmark of many digenean taxa to be in part defined by their range of hosts in this way. In contrast, the Echinostomatoidea occur almost equally in vertebrates and molluscs and the Gymnophalloidea and Lepocreadioidea occur in at least six and seven different phyla, respectively.

Just two clades of digeneans are frequent parasites of arthropods – the Hemiuroidea and the Xiphidiata (Table 2, Figure 6). The Hemiuroidea

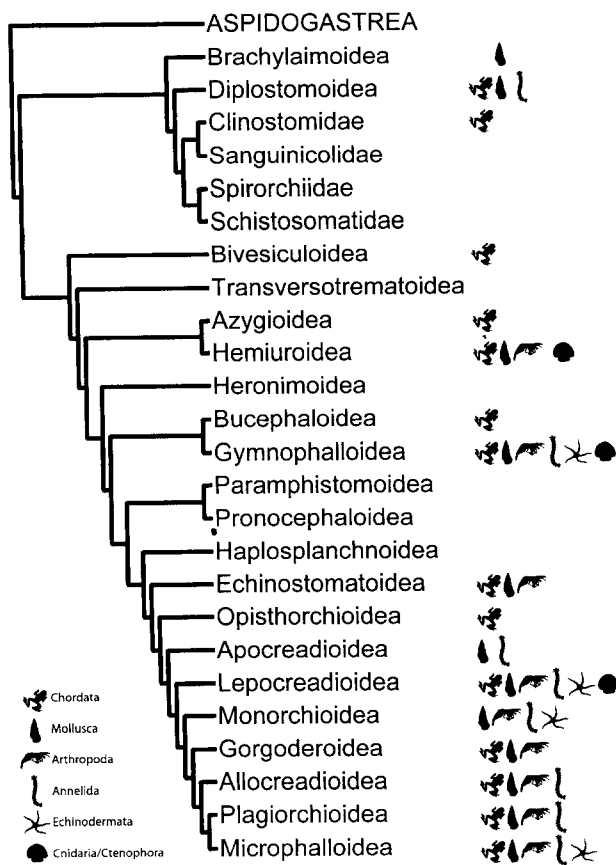

Figure 6 Digenean life cycle variation – phyla exploited as second intermediate hosts. Lepocreadioidea infects all six shown phyla – Chordata, Mollusca, Arthropoda, Annelida, Echinodermata and Cnidaria (coded with Ctenophora). Platyhelminthes and Chaetognatha are not shown.

infect crustaceans and insects by way of their specialized cystophorous cercaria which penetrates the gut of the intermediate host and injects the cercarial body into the haemocoel (e.g., see Køie, 1990). The few records of metacercariae of hemiuroids in chaetognaths, molluscs and vertebrates are likely to be reports of third intermediate hosts that have consumed infected arthropods (e.g., Zelmer and Esch, 1998); hemiuroid evolution may thus be completely coupled to arthropod second intermediate hosts. In contrast to the Hemiuroidea, the Xiphidiata have adopted external penetration of

Table 2. Second intermediate hosts. Counts are of phyla recorded as second intermediate hosts for individual species. A species might be counted more than once if shown to infect, e.g., a mollusc and a vertebrate, but not if infecting multiple species of molluscs. Superfamilies with no or negligible use of second intermediate hosts are excluded.

Superfamily	Annelida	Arthropoda	Chaeto- gnatha	Cnidaria	Ctenophora	Echino- dermata	Mollusca	Platyhel- minthes	Vertebrata	Total
DIPLOSTOMIDA										
Brachylaimoidea							20			20
Diplostomoidea	4						5		76	85
Schistosomatoidea									11	11
PLAGIORCHIIIDA										
Apocreadioidea	1						2			3
Echinostomatoidea		1					29		19	49
Hemiuroidea		24	4	1			1		1	31
Lepocreadioidea	3	1			2		4	1	3	18
Monorchioidea	1	1			1		7	2		12
Opisthorchioidea									63	63
Bucephalata										
Bucephaloidea									16	16
Gymnophalloidea	1				3		10		1	16
Xiphidiata										
Allocreadioidea	1	27					5		8	41
Gorgoderoidea		18					4		5	27
Microphalloidea	2	50			1		3		1	57
Plagiorchioidea	4	20					12		17	53
Total	17	142	4	5	1	7	102	3	221	556

arthropods. This is the taxon most frequently reported from arthropods, but at least 13 species from this clade are reported to be capable of infecting more than one phylum of intermediate hosts and some species are known from three phyla (Angel, 1967; Jue Sue and Platt, 1998). Approximately one-third of our records of metacercariae of Xiphidiata are from non-arthropods. We conclude that evolution of the stylet conferred the capacity to infect arthropods by penetrating their cuticle or arthroal membranes, but that, in contrast to the Hemiuroidea, this was not at the expense of the ability to infect other groups of animals.

We conclude that many digenean taxa that have three-host life cycles are linked strongly to a phylogenetic group of intermediate hosts and that three-host cycles have arisen repeatedly. Hypotheses that consider the evolutionary history of individual digenean taxa should thus incorporate reference to the identity of the second intermediate host.

4.3. Definitive Hosts

We have mapped the distribution of definitive hosts on the phylogeny of the Digenea at the simplest level possible – chondrichthyans, teleosts and tetrapods (Figure 7). In this context the Aspidogastrea are uninformative as they occur in all three groups; they do, however, present a strong contrast to the Digenea in that three of their four families occur in chondrichthyans. Determination of the basal host group is made more complicated by problems with the interpretation of the evolutionary status of the definitive host of the blood fluke families (see Section 4.9, p. 234). If for this reason the Diplostomida are ignored, the analysis of the Plagiorchiida alone shows that the basal host group was unambiguously teleosts. This has been well accepted; most hypotheses for the evolution of the Digenea argue that the subclass arose in association with marine teleost fishes (Cable, 1974).

It is noteworthy that so few clades of digeneans occur in chondrichthyans, and that most of these have apparently host-switched from teleosts or are accidental infections (Bray and Cribb, 2003). In these categories are the Acanthocolpidae, Bucephalidae, Faustulidae, Gorgoderidae, Opecoelidae and Zoogonidae; each of these families occurs mainly in teleosts. There are three families that are not so easily explained because of their near-basal position in the case of the Ptychogonimidae and Azygiidae or the complexity of their host distribution in the case of the Sanguinicolidae, but all three require further study as discussed by Bray and Cribb (2003). Thus, the available data support an origin for the Digenea in association with teleosts followed by host-switching into chondrichthyans.

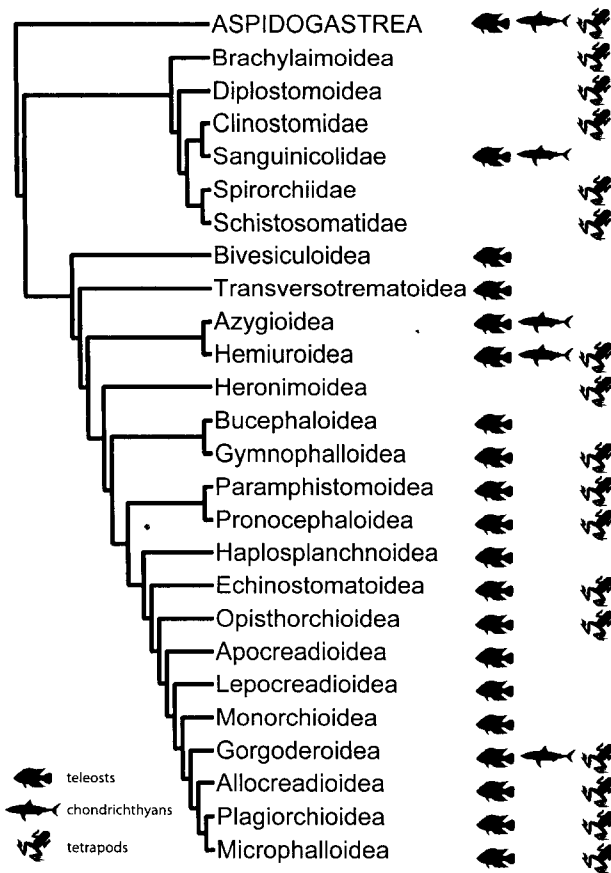

Figure 7 Digenean life cycle variation – definitive hosts coded as teleosts, chondrichthyans and tetrapods.

Adoption of parasitism in tetrapods can be considered, conveniently, in the Plagiorchiida and Diplostomida as separate sets of events. Parasitism of tetrapods is rare among the more basal Plagiorchiida (Figure 7). The two most basal taxa within the Plagiorchiida (Bivesiculoidea and Transversotrematoidea) are entirely parasites of fishes. Parasitism of tetrapods has arisen within one superfamily of the Hemiurata, the Hemiuroidea, which, although overwhelmingly parasites of teleosts, have adopted occasional parasitism of amphibians and reptiles. The monotypic Heronimoidea is the only plagiorchiidan superfamily to be restricted to tetrapods; it is restricted to freshwater turtles. The Gymnophalloidea comprise four families of

parasites of teleosts and the Gymnophallidae which parasitize birds (occasionally mammals). Parasitism of tetrapods tends to be more significant in the more derived clades although the Haplospalchnoidea, Apocreadioidea, Lepocreadioidea and Monorchioidea are all found mainly or entirely in fishes.

The Echinostomatoidea comprises principally parasites of tetrapods. The Paramphistomoidea + Pronocephaloidea are overwhelmingly parasites of tetrapods, although the Paramphistomoidea are well represented in freshwater fishes. The Opisthorchioidea is a major clade occurring in fishes, reptiles, birds and mammals. The life cycle within this family is highly uniform, depending upon a metacercaria in a fish being eaten by the definitive host. The distribution of opisthorchioids, essentially defined by a fish-eating host diet, suggests that the appearance of this clade in tetrapods is the result of a host-switch from fish. The final clade of Plagiorchiida that has radiated significantly among tetrapods is the Xiphidiata. This clade comprises four superfamilies. All four include substantial clades (families) of both fish and tetrapod parasites. The Plagiorchioidea are overwhelmingly parasites of tetrapods, except for the Macroderoididae of freshwater fishes, and it is possible that this family represents a secondary colonization of fishes. The Gorgoderioidea includes such major taxa of fish parasites as the Gorgoderidae as well as quintessentially terrestrial tetrapod parasites, the Dicrocoeliidae. Of particular interest within this clade is the Gorgoderidae itself, members of which infect teleosts, chondrichthyans and tetrapods. The Allocreadioidea are apparently restricted to fishes except for the Brachycladiidae, which are parasites of marine mammals. The Microphalloidea is heavily concentrated among tetrapods (e.g. Lecithodendriidae, Microphallidae, Pleurogenidae, Prosthogonimidae and Rencolidae) but has one major radiation within fishes, the Zoogonidae + Faustulidae. The topology of relationships within the Xiphidiata might suggest either that parasitism of tetrapods arose several times within the Xiphidiata or that they have switched back into fishes more than once.

In contrast to the Plagiorchiida, the hosts of the Diplostomida present a puzzle. All but one of the six resolved clades shown in Figure 7 are parasites of tetrapods. The only clade with adults of some species in fishes is the Sanguinicolidae, and this clade is apparently as derived as any within the Diplostomida. Bray *et al.* (1999) reported urotrematids from Chinese freshwater fishes. It is possible that these trematodes belong in the Diplostomida, but this has not yet been demonstrated. This host distribution implies that the clade of the Diplostomida, having presumably arisen with fishes, has either coevolved away from or, with the exception of the Sanguinicolidae, host-switched out of fishes. The distribution becomes even more surprising when it is realized that blood fluke life cycles are

usually considered to be abbreviated three-host life cycles in which a gastrointestinal adult has been lost. Indeed, this has been the dominant and consistent interpretation of the group to the exclusion of any other interpretation of which we are aware (La Rue, 1951; Pearson, 1972; Cable, 1974; Brooks *et al.*, 1985; Shoop, 1988; Kearn, 1998). This interpretation means that effectively no extant member of the Diplostomida is primarily a parasite of a fish. What can account for this unexpected host distribution? This question is revisited when we attempt to resolve an evolutionary history for the Diplostomida as a whole.

4.4. Infection Processes – Miracidial Behaviour

All digeneans have a sexual generation that produces eggs. These eggs embryonate, either within or outside the host, to produce a miracidium. Digenean miracidia vary significantly in their morphology, but here we consider just one important behavioural trait – whether the miracidium hatches and infects the mollusc independently or is eaten by the mollusc and penetrates internally. Occurrences of ingestion of the egg are mapped in Figure 8 (shaded taxa); eggs are eaten in all Brachylaimoidea, Hemiurata, Pronocephaloidea, Opisthorchioidea and Monorchioidea and in several families of the Xiphidiata. Hatching of the miracidium and active host-finding is inferred to be plesiomorphic. Passive ingestion of eggs of the Brachylaimoidea and Dicrocoeliidae (Xiphidiata) are key adaptations in association with completely terrestrial life cycles.

4.5. Rediae and Sporocysts

All digeneans undergo asexual reproduction within a first intermediate host. The basic pattern appears to be a mother sporocyst (the adult of the miracidium) which produces a second generation of sporocysts or rediae. Life cycles in which there is reported to be only a single asexual generation (Heronimidae, Bucephalidae) are, by the position of their appearance in the phylogeny, almost certainly secondary reductions from patterns with two generations. Both heronimids and bucephalids have enormous branching sporocysts so that the need for a second generation may have been lost in both cases. Another interpretation is possible. The mother sporocyst generation may simply be so reduced as to be almost unrecognizable. The miracidium in the Heronimidae contains germinal balls, which are initially enclosed by a fine membrane. Gibson (1987) and

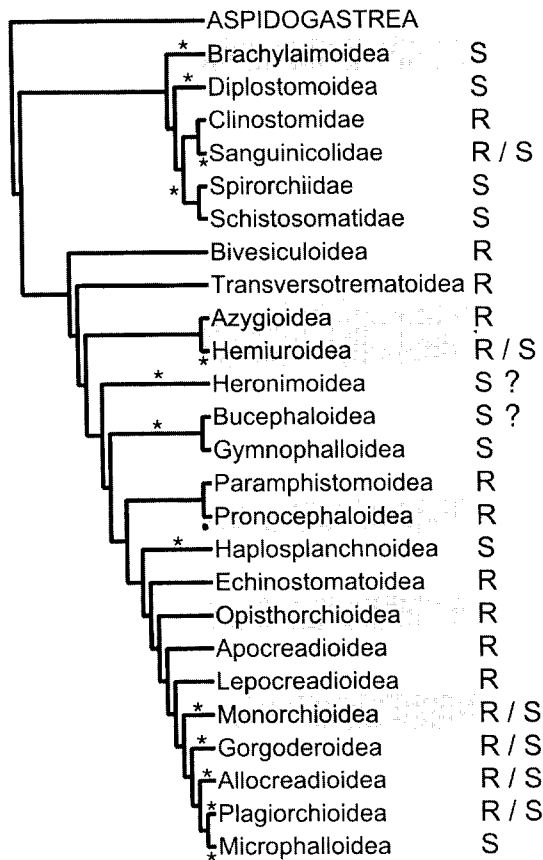

Figure 8 Digenean life cycle variation - behaviour of miracidia; cercaria-producing generation. Shaded taxa are those in which the ingested egg is the strategy adopted by the entire superfamily. R, redia; S, sporocyst. Taxa marked with an asterisk (*) are inferred to have derived sporocysts. The query (?) next to Heronimoidea and Bucephaloidea reflects uncertainty about which generation is present (mother or daughter sporocyst).

others have suggested that this membrane may represent a highly reduced single second generation. Further indications of such reduction are seen in taxa in which the miracidium contains only a single redia (e.g. all Cyclocoelidae and the paramphistome *Stichorchis*). The possibility of the presence of only a single intra-molluscan generation is not considered further here.

Apart from the issue of the number of generations, perhaps the major observation to be made about the intra-molluscan stages is in the distinction between rediae (possessing a mouth, a pharynx and a short saccular gut) and sporocysts (which have no organs at all). Mapping of this character (Figure 8) shows that both sporocysts and rediae occur widely in the Digenea. Analysis of this distribution indicates that rediae have given rise to sporocysts. This may have happened as many as four times in the Diplostomida and at least nine times in the Plagiorchiida (clades in which sporocysts are inferred to have evolved are marked with an asterisk). The frequency of this evolutionary change suggests that this derivation occurs relatively easily. It is intriguing that the sporocyst should be the derived condition in the light of findings which have shown that in inter-specific interactions within a mollusc, rediae often eat and dominate sporocysts (Lim and Heyneman, 1972).

Our compilation of life cycle data revealed a surprising correlation. Of the taxa that occur in bivalves as first intermediate hosts (Allocreadiidae, Bucephalata, Faustulidae, Gorgoderidae, Monorchidae and some Sanguinicolidae) only the Allocreadiidae have rediae. Even the single hemiuroid from a bivalve, identified as such by the cystophorous cercaria (Wardle, 1975), has a sporocyst. In the Allocreadiidae, the redia has a pharynx, but the gut is often described as being very small or even absent (Caira, 1989). Thus, we can infer cautiously that parasitism of bivalves has promoted the derivation of sporocysts from rediae. It is not clear why the infection of bivalves and the derivation of sporocysts should be correlated.

The Schistosomatoidea is particularly interesting in the distribution of sporocysts and rediae (Figure 8). Within the clade Clinostomidae + Sanguinicolidae, rediae are found in some sanguinicolids in polychaetes and in all Clinostomidae whereas those sanguinicolids that infect bivalves and gastropods always have sporocysts. The other clade (Schistosomatidae + Spirorchidae) also always has sporocysts. The Sanguinicolidae is not only the only digenean family to use both of the major categories of first intermediate hosts extensively but it is one of few in which either rediae or sporocysts can be the second generation.

Whereas rediae are dominant in the Hemiuroidea, sporocysts are not uncommon and have been reported from four families of which three are also reported to have rediae. Pearson (1972) reviewed evidence that showed that the ontogeny of at least some of the species in this superfamily includes a redia that loses traces of its gut to become a sporocyst. Thus, at least in part, the Hemiuroidea may illustrate the process that led to the development of sporocysts in general.

4.6. Cercarial Tails

Figure 9 shows the distribution of the two basic kinds of cercarial tails – forked and simple (shaded). The distribution is remarkably free of ambiguity. The fork-tailed cercaria is clearly the plesiomorphic form, a conclusion

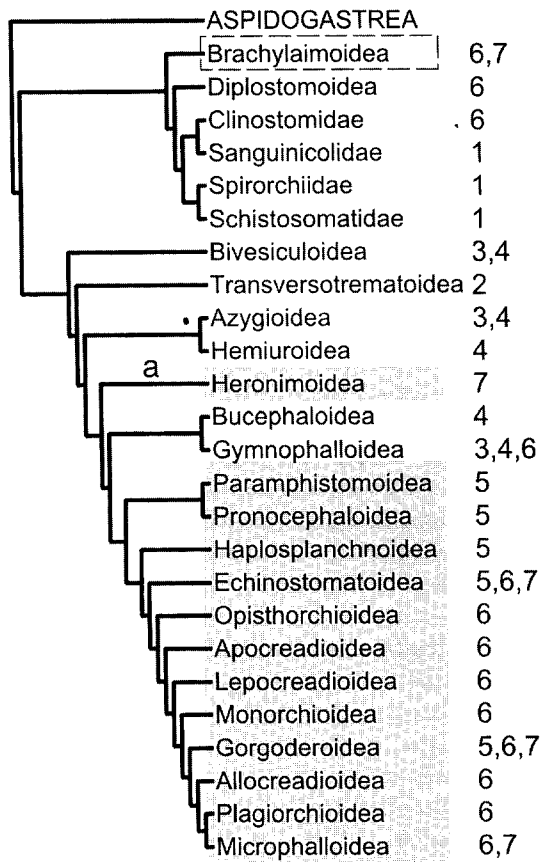

Figure 9 Digenean life cycle variation – cercarial tail; behaviour of cercaria. Shaded taxa have simple tails; the dashed 'box' indicates that only some taxa within the clade have simple tails. The only clade at the superfamily level in which the cercaria does not emerge from the first intermediate host is marked 'a'. 1. Cercaria penetrates definitive host directly. 2. Cercaria attaches directly to definitive host. 3. Cercaria eaten directly by definitive host. 4. Cercaria eaten by second intermediate host. 5. Cercaria emerges from mollusc and encysts in the open. 6. Cercaria emerges from mollusc and penetrates second intermediate host externally. 7. Cercaria remains in first intermediate host which is eaten directly by definitive host.

reached by Cable (1974). Modification to a simple tail has apparently occurred perhaps only three times for major clades. In the Diplostomida, it is modified into a simple, almost absent, tail in the Brachylaimoidea that use terrestrial molluscs; the aquatic Leucochloridiomorphidae retain a typical forked-tail. In the Plagiorchiida, separate derivations have apparently occurred in the Heronimoidea and in the huge clade comprising the Paramphistomata + all other more derived Plagiorchiida. There is also evidence for derivation of a simple tail within some otherwise forked-tailed taxa (Køie, 1979). There is no evidence that a forked-tail has ever been acquired secondarily. The topology of the phylogeny of the Digenea given by Cribb *et al.* (2001) led them to suggest that the forked-tailed cercaria of the Bucephalidae had been developed secondarily but the new topology suggests that this is not the case. Cribb *et al.* (2001) suggested that the derivation of the simple cercarial tail correlated with the abandoning of direct pursuit of the host. This hypothesis requires that highly derived taxa such as the Opisthorchioidea and Xiphidiata, which penetrate intermediate hosts but have a simple tail, were derived via forms that encysted without an intermediate host. This interpretation is supported here.

4.7. Infection Processes – Cercarial Behaviour

The digenean cercaria can behave in many distinct ways that ultimately lead to the infection of the vertebrate definitive host. We recognize seven distinct behaviours that are mapped in Figure 9.

- (i) The cercaria may penetrate the definitive host directly. This behaviour occurs only in some Schistosomatoidea (Schistosomatidae, Spirorchiidae and Sanguinicolidae).
- (ii) The cercaria attaches to the surface of the definitive host. This behaviour occurs only in the Transversotrematidae.
- (iii) The cercaria is eaten directly by the definitive host. This behaviour occurs in several clades – Bivesiculidae, Azygiidae, Fellodistomidae and Tandanicolidae (but not in all individuals of these clades).
- (iv) The cercaria is eaten by a second intermediate host, and then frequently penetrates the gut. A metacercaria forms and waits for the definitive host to eat the second intermediate host. This behaviour is probably general in the Hemiuroidea but occurs notably elsewhere in some Fellodistomidae and Gorgoderidae and rarely in the Bivesiculidae and Azygiidae.
- (v) The cercaria emerges from the mollusc, encysts in the open as a metacercaria on a potential food source of the definitive host, and

waits there to be eaten. This behaviour is found in several clades (Paramphistomata, Haplospianchoidea, some Echinostomatoidea and Haploporidae from within the Gorgoderoidea).

- (vi) The cercaria emerges from the mollusc and penetrates a second intermediate host externally. A metacercaria forms and waits for the definitive host to eat the second intermediate host. This is the most common life cycle form in the Digenea, both in terms of numbers of species and numbers of families. It occurs in most of the Diplostomida, Bucephaloidea, Opisthorchioidea, Echinostomatoidea and Lepocreadioidea, and overwhelmingly in the four superfamilies of the Xiphidiata.
- (vii) The cercaria remains in the first intermediate host, which is eaten directly by the definitive host. This behaviour is found in the Heronimidae, Cyclocoelidae (Echinostomatoidea), Eucotylidae (Microphalloidea) and Hasstilesiidae and Leucochloridiidae (Brachylaimoidea) and sporadically elsewhere.

In our view, all other cercarial behaviours within the Digenea are either derivations or reductions of these seven basic types. Derivations include extension of the life cycle to four hosts as seen in some Hemiuroidea (Madhavi, 1978; Gibson and Bray, 1986; Goater *et al.*, 1990) and Diplostomidae (Pearson, 1956) and numerous secondary abbreviations of the life cycle (Poulin and Cribb, 2002). The extent to which the seven behaviours may be derivable from each other is discussed here. Determining which of the behaviours might be basal for the Digenea is made complex because there are so many of them. To reiterate, our approach has been to use a combination of outgroup comparison (including the key assumption that two-host cycles preceded three-host cycles) and parsimonious inference from within the phylogeny of the Digenea.

The six behaviours in which the cercaria emerges (behaviours i–vi) numerically overwhelm that in which it remains within the mollusc (behaviour vii). Behaviour (vii) is characteristic only of the monotypic Heronimoidea (node a, Figure 9), but it also appears within the Brachylaimoidea (Hasstilesiidae and Leucochloridiidae), the Echinostomatoidea (Cyclocoelidae) and the Microphalloidea (Eucotylidae) and in some taxa within many other families. The relatively derived and usually nested positions of taxa that exhibit this behaviour allow us to infer that this behaviour has evolved many times. Thus, retention of the cercaria within the mollusc, to be eaten with the mollusc by the definitive host (life cycle pattern either analogous or homologous to that of the Aspidogastrea), is a derived state in the Digenea. Emergence of the cercaria is a synapomorphy for the Digenea relative to the Aspidogastrea and a plesiomorphic trait

within the Digenea. Thus, as argued by Pearson (1972), an evolutionary hypothesis for the Digenea must account for the emerging cercaria as a plesiomorphic character for the Digenea, unless extinct forms are invoked.

We can now use this inference, the topology of the tree and the distribution of cercarial emergence to consider which emergent cercarial behaviour is plesiomorphic. We have presented evidence that a two-host life cycle of some sort preceded the three-host life cycle; outgroup comparison and simple logic both suggest that two-host life cycles preceded three-host cycles. We can thus conclude that behaviours (vi) and (iv) are not plesiomorphic. Behaviour (vi), external penetration of a second intermediate host, appears first in relatively highly derived taxa (Bucephalata and higher taxa, see Figure 9), and so cannot be inferred to be plesiomorphic. Behaviour (iv), ingestion of the cercaria by a second intermediate host, appears in some of the relatively basal Azygioidea and Gymnophalloidea, and generally in the Hemiuroidea and in the highly derived Gorgoderidae. This three-host life cycle may be derived from ingestion of the free-living cercaria by the definitive host in the case of the Gymnophalloidea and the Hemiuroidea and from the more common standard penetrating three-host cycle in the case of the Gorgoderidae.

There are four behaviours involving two-host cycles in which the cercaria emerges from the mollusc, which may be plesiomorphic. Behaviour (i), direct penetration of the definitive host, occurs only in derived Diplostomida (Figure 9). This behaviour cannot therefore be considered plesiomorphic for the Digenea (but see Section 4.9, p. 234). Behaviour (ii), attachment of the cercaria, is seen only in the relatively basal Transversotrematoidea. This is the only life cycle within the Plagiorchiida that leads to infection other than, ultimately, by ingestion. It is not parsimonious to infer that this life cycle strategy was basal to all others in this clade. Behaviour (v), encystment in the open on a food source, is found in the relatively derived taxa – Paramphistomata, Echinostomatoidea, Haplospalchnoidea and the Haploporidae. Encystment in the open followed by ingestion is easily derived from ingestion of a free-swimming cercaria whereas the reverse is not necessarily the case. Again, it is not parsimonious to infer that this life cycle strategy was basal to all others in this clade.

Behaviour (iii), ingestion of the free-swimming cercaria, is found in the most basal taxon of the Plagiorchiida, the Bivesiculoidea, and in at least some representatives of two other relatively basal clades, the Azygioidea and Gymnophalloidea. The behaviour is simple and could have arisen easily by the ingestion of a free-swimming cercaria. The intuitive objection to this hypothesis is that it seems improbable that the cercaria could survive the digestive tract, especially the stomach, of its host. The evidence, however, is

that this happens in several digenean taxa. Thus, we conclude that ingestion of a free-swimming cercaria is both parsimoniously and plausibly plesiomorphic for the Digenea. This conclusion may also have the implication that the first host in the digenean life cycle was a mollusc, that the ancestor of digeneans had a free-swimming adult, and that the vertebrates were added secondarily. Problems associated with these possibilities are discussed in Section 5.2 (p. 241).

4.8. A Hypothesis of Evolution within the Plagiorchiida

The individual hypotheses that have been derived above can now be combined into an overall hypothesis for life cycle evolution. This is done separately for the Plagiorchiida and the Diplostomida (see Section 4.9, p. 234) because there remain substantial difficulties in the interpretation of the Diplostomida, but both sets of hypotheses refer to the same set of inferences regarding plesiomorphic life cycle traits for the Digenea. A parsimonious hypothesis for the evolution of major life cycle traits within the Plagiorchiida is shown in Figure 10 using just 16 key taxa from the group. Most of the life cycle diversity within the group can be explained by 20 key evolutionary changes that are described below. The numbers below refer to clades labelled in Figure 10.

Plesiomorphic life cycle characters for the Digenea (1). The analyses above suggest that the common ancestor to extant Digenea had a miracidium that hatched from the egg and penetrated a gastropod. The second asexual generation developed into a redia that produced fork-tailed cercariae, which emerged from the gastropod to be eaten passively by a teleost definitive host. There was no second intermediate host. This combination of characters is found without modification in some Bivesiculidae, the most basal taxon within the Plagiorchiida.

Although apparently plesiomorphic in its life cycle, the Bivesiculidae is not necessarily primitive in all respects. A striking feature of the family is its lack of oral and ventral suckers. Absence of suckers has been commented on previously as perhaps consistent with a basal position for this family and plesiomorphic absence of suckers in the Digenea, but their wide occurrence in both the Diplostomida and Plagiorchiida leads to the parsimonious inference that oral and ventral suckers are indeed plesiomorphic for the Digenea. These parasites occur in the intestines of their host and there is no ready explanation for the absence of suckers if it has occurred by their loss. Thus, absences of suckers in this taxon may be apomorphies. A study of the homology of oral and ventral suckers in the Diplostomida and Plagiorchiida might shed fresh light on this matter. Whereas most evidence about

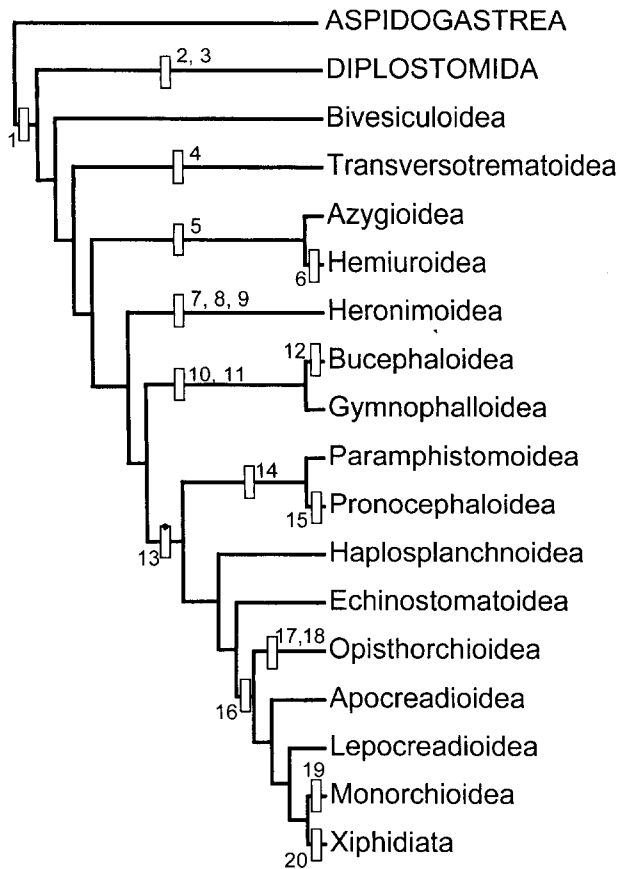

Figure 10 A hypothesis for the evolution of life cycles within the Plagiorchiida. Numbered evolutionary changes are described in the text.

bivesiculids is consistent with a two-host cycle, Cribb *et al.* (1998) showed that at least one species has incorporated (perhaps facultatively) a second intermediate host. A mother sporocyst has never been described in the Bivesiculidae. The basal position of this taxon suggests this may be informative.

Cercaria penetrates; infection of tetrapods (2,3). Penetration of a host by the cercaria is a possible synapomorphy for the Diplostomida; it is clearly independent of cercarial penetration in other taxa in the higher Plagiorchiida. The clade may also be defined by the adoption of parasitism of tetrapods as definitive hosts (see further discussion Section 4.9, p. 234).

No synapomorphy. This hypothesis proposes no life cycle synapomorphy for the Plagiorchiida.

Cercaria attaches externally to scaled fish (4). This character is an autapomorphy for the Transversotrematidae. We argued above (p. 226) that the two-host life cycle of the Transversotrematidae, which incorporates direct attachment of the cercaria, could not be inferred to be basal to that of the remainder of the Plagiorchiida. The topology of the tree means that it is thus most parsimonious to interpret it as a direct modification of the bivesiculid-type life cycle. We have mapped this as a single change. However, at least three plausible hypotheses can account for this life cycle: a two-host (ingestion) life cycle in which the cercaria has exchanged passive ingestion for active attachment (as mapped, Figure 10); an abbreviated three-host life cycle from which the third (definitive) host has been omitted; or a two-host life cycle derived independently of other digenean life cycles.

Counting changes in life cycle traits in the competing hypotheses (not shown) suggests that derivation of the cycle from a two-host ingestion cycle is the most parsimonious, if modification of the life cycle from ingestion to attachment can be construed as a single step. This may be overly optimistic as it implies complex changes. The hypothesis that the life cycle is abbreviated was proposed by Brooks *et al.* (1989), who suggested that the life cycle had been abbreviated from three to two hosts. Although this scenario is plausible, it has neither supporting evidence nor is it parsimonious in the context of the new topology of the Digenea. The hypothesis that the life cycle was derived independently by a free-swimming cercaria becoming associated with the surface of fishes is simple and requires just one step of derivation for the Transversotrematidae itself, but the topology of the remainder of the tree would then require that vertebrate parasitism was adopted at least three times in the Plagiorchiida. This is significant. The discussion in Sections 4.3 and 4.7 assumed that parasitism of vertebrates had arisen only once. This interpretation is suggested initially by both outgroup comparison and parsimony. However, the assumption may be false. We concluded that basal digeneans infected vertebrates by ingestion of a free-swimming cercaria. This interpretation may mean that outgroup comparison (with the *Aspidogastrea*) is uninformative (or indeed misleading) in this case. If this is the case, then separate adoptions of vertebrate parasitism within the Digenea may need to be considered. In this context, it is noteworthy that the cercaria of the Transversotrematidae is one of the most remarkable in the Digenea. It has unique arms at the base of the tail and it may be sexually mature with sperm in the seminal vesicle. Sexual maturity of the cercaria may be an echo of

a free-swimming sexual adult. However, the plasticity of cercariae seen elsewhere shows that we must be highly cautious in such inferences. The origin of the transversotrematid life cycle certainly requires further investigation.

Eggs eaten (5). This life cycle character (and the associated morphological modification of the miracidium) unites the Azygioidea and the Hemiuroidea. The two-host life cycles of azygiids differ from the basal form as represented by the Bivesiculidae only in the behaviour of the miracidium, which must be eaten. The sexual adults of azygiids are quite distinct, however, as they have oral and ventral suckers. Some, perhaps most, azygiids have expanded their life cycles to three hosts but this is interpreted as a within-clade derivation that does not affect the apparently plesiomorphic status of the two-host life cycle.

Cercaria eaten by intercalated arthropod second intermediate host (6). The Hemiuroidea is a huge taxon comprising over 300 genera (including the Didymozoidae). The ingestion of the cercaria by an arthropod intermediate host is here interpreted as the intercalation of an extra host in a life cycle in which the plesiomorphic condition was the cercaria being eaten directly by the definitive host. The Hemiuroidea, some of the Gymnophalloidea and the Gorgoderidae are the only clades in which the cercaria is ingested by the second intermediate host. All other three-host life cycles are characterized by external cercarial penetration.

Cercaria remains in, and is transmitted by the ingestion of the first intermediate host; cercarial tail reduced to simple; hosts tetrapods (7-9). The two-host cycle of the Heronimoidea is here interpreted as the result of the abbreviation of a cycle in which the cercaria previously emerged. The nature of the unabbreviated life cycle cannot be deduced, but the simplest abbreviation would have been of a life cycle in which the free-living cercaria was eaten directly. The fact that this clade is represented by a single species infecting the unusual site of the lungs of a freshwater turtle suggests that this clade is a relict *sensu* Brooks and Bandoni (1988). Certainly the Heronimoidea appears to have no significant bearing on understanding the overall evolution of digenean life cycles as it did when Brooks *et al.* (1985) inferred that it might be the sister-group to the remainder of the Digenea. However, it does represent the first appearance of a simple tail within the Plagiorchiida.

Host-switch to bivalves; derivation of sporocysts (10-11). The shared parasitism of bivalves as first intermediate hosts and the derivation of sporocysts unite the Bucephaloidea and Gymnophalloidea as a clade. Some two-host fellodistomid and tandanicolid life cycles differ from the basal form only in the parasitism of bivalves and the derivation of sporocysts; as noted earlier, these characters may be linked. Some,

perhaps most, fellodistomids have expanded their life cycles to three hosts but this is again interpreted as a within-clade derivation that does not affect the inferred plesiomorphic status of the two-host life cycle.

Cercaria penetrates intercalated second intermediate fish host (12). The Bucephalidae are parasitic in the intestines of fishes. The life cycle is uniformly three-host, involving the penetration of a fish and subsequent formation of a metacercaria in its tissues. There is no particular clue from living bucephalids to suggest how the three-host cycle might have arisen. We can only speculate that the capacity of cercariae to survive in association with the surface of fishes, that they once contacted accidentally, improved the overall chances of the parasite finally to be ingested by the definitive host. The origin of the remarkable cercarial tail of the Bucephalidae (furcate, but without a tail-stem) remains unexplained but it is noteworthy that K ie (1979) has shown that the same condition can also exist in the related Fellodistomidae.

Cercarial tail simple (+ encystment in open?) (13). This character unites all remaining Plagiorchiida: Haplospinoidea + Echinostomatoidea + Paramphistomata + Opisthorchioidea + Lepocreadioidea + Xiphidiata. Cribb *et al.* (2001) suggested that derivation of simple tails may relate to the adoption of external encystment. They argued that cercariae that have forked tails typically swim faster than those that have simple tails. Presumably this is energetically expensive. Thus, slower, more efficient swimming by a cercaria that will encyst in the open rather than pursue a host may have been selected for. We hypothesize that encystment in the open and presence of a simple tail are linked characters. Encystment in the open can be derived from the ingestion of a free-swimming cercaria. It requires only that the cercaria finds a suitable substrate and secretes some kind of protective cyst. This behaviour is characteristic of the Paramphistomata, the Haplospinoidea and the Echinostomatoidea (although three host cycles do arise within this last clade). These taxa combine to represent a considerable number of species, pointing to the substantial advantage conferred by cercarial encystment which prolongs the effective life of the cercaria.

Encystment on vegetation - specialization for herbivory? (14). This character is used here rather speculatively to define the Paramphistomata (Prionocephaloidea + Paramphistomoidea). These trematodes have two-host life cycles in which the cercaria encysts in the open. Paramphistomata have radiated widely among herbivores and their key innovation may have been encystment on vegetation, although prionocephaloids often encyst on mollusc shells and infect carnivorous hosts as well. This life cycle strategy has apparently never expanded to a true three-host cycle, defined here as growth of the metacercaria at the expense of the second intermediate host.

An association between this clade and herbivory may also be suggested by the morphology of the adults. Both the Pronocephaloidea and the Paramphistomoidea lack an oral sucker (or pharynx) and the Pronocephaloidea and some Paramphistomoidea lack a ventral sucker. Both modifications undoubtedly affect feeding behaviour and these losses may reflect a move to ingestion of gut contents instead of browsing on the mucosa. These characteristics require further analysis but, for the present, we propose that they can be usefully combined as a single character – “specialization for herbivory”.

Egg eaten (15). Ingestion of the egg appears to distinguish the Pronocephaloidea from the Paramphistomoidea, although the behaviour has not been sufficiently studied in a wide range of taxa.

No synapomorphies: Haplospalchnoidea and Echinostomatoidea. In contrast to the Paramphistomata, these superfamilies are not here defined by life cycle synapomorphies. The simplest life cycles in these clades are those in the Haplospalchnidae and, in the Echinostomatoidea, some Philophthalmidae, Psilostomidae, Fasciolidae and Echinostomatidae in which the cercaria encysts in the open, usually in association with the surface of potential prey items (especially molluscs) or vegetation eaten by the definitive host. The life cycle is associated with herbivory only in the Haplospalchnidae of marine fishes and the derived Fasciolidae of terrestrial mammals. Neither superfamily has modified feeding or attachment structures as are seen in the Paramphistomata. The Echinostomatidae, by far the largest group within the Echinostomatoidea, usually encyst in association with animals. The derivation of three-host cycles within the clade is seen clearly in the Echinostomatidae and Psilostomidae where a range of levels of association with intermediate hosts leads to a true three-host life cycle. In addition, within this clade the Cyclocoelidae is characterized by an apparently abbreviated life cycle in which the cercaria encysts within the first intermediate host.

Cercaria penetrates intercalated second intermediate (invertebrate?) host (16). This character appears to define the clade comprising all remaining plagiorchiid taxa which, except by apparent secondary modification (e.g. Eucotylidae, Haploporidae, some Monorchidae), uniformly use second intermediate hosts that are penetrated externally with the assistance of penetration glands. It seems likely that three-host cycles appeared in the same way that is shown by the range of extant Echinostomatoidea – external association leading to progressively more intimate association and penetration.

Second intermediate hosts exclusively vertebrates; eggs eaten (17 and 18). The Opisthorchioidea represents a substantial clade of trematodes that uniformly have a three-host life cycle in which fishes and occasionally

amphibians are exploited as second intermediate hosts. The position in the phylogeny occupied by the Opisthorchioidea implies that the superfamily adopted fish as intermediate hosts independently of any other clade of digeneans. The opisthorchioid cercaria is highly distinctive, uniform and apparently specialised for this behaviour. This is the third clade of the Plagiorchiida in which eggs are always eaten by the molluscan intermediate host. The fact that this is an independent development in each clade is shown by the morphological distinctions between the eggs and miracidia in each clade.

No synapomorphies: Lepocreadioidea and Apocreadioidea. These superfamilies each lack a clear life cycle synapomorphy. These clades include many large families most of which are essentially intestinal parasites of teleost fishes, have gastropods as first intermediate hosts and have cercariae produced in rediae. All have cercariae that penetrate a wide range of invertebrate and vertebrate hosts with the conspicuous exception of any significant presence in arthropods. The lepocreadioid clade comprising the Gorgocephalidae, Enenteridae and Gyliuchenidae (Olson *et al.*, 2003) remains without an elucidated life cycle. All these families are concentrated in herbivorous fishes and it is possible that their life cycles are secondarily reduced and have metacercariae that are associated with algae.

Egg eaten (19). The Monorchioidea appear to be united by the necessity for the egg to be ingested by the first intermediate host. Otherwise life cycles in this superfamily broadly resemble those of the Apocreadioidea and Lepocreadioidea.

Stylet in oral sucker; arthropods adopted as main second intermediate hosts (20). The Xiphidiata are united by the presence of a stylet in the oral sucker. This structure appears to have made possible the penetration of arthropod cuticle or arthrodiol membranes. Arthropods are more heavily exploited by the Xiphidiata than by any other clade of digeneans. By contrast, the Lepocreadioidea, Monorchioidea and Apocreadioidea, the three taxa immediately basal to the Xiphidiata, are either rare in or absent from arthropods. This clade includes the Haploporidae, parasites of fishes with a two-host life cycle in which the cercaria, lacking a stylet, encysts in association with algae. Membership of this clade is either an indication that this two-host cycle has evolved by the loss of a second intermediate host (and the stylet) or that it has been misplaced in the present phylogeny.

Overall the Plagiorchiida present a comprehensible system with origins in fishes and simple two-host life cycles followed by developing life cycle complexity, the adoption of second intermediate hosts, and repeated expansion with and into tetrapods.

4.9. Hypotheses of Evolution within the Diplostomida

It was a major finding of Olson *et al.* (2003) that there is a basal dichotomy in the Digenea between the Plagiorchiida and the Diplostomida. The depth and significance of this dichotomy is reflected in differences in the life cycles seen in the two clades. Inference of the pattern of evolution within the Diplostomida is considerably more difficult than for the Plagiorchiida because the basal taxon, the Brachylaimoidea, have three-host life cycles and parasitise tetrapods. As noted above, outgroup comparison and simple logic dictate that a two-host life cycle precedes a three-host cycle. In addition, parsimony analysis shows that the basal hosts for the Digenea were teleost fishes. Thus, in several important respects the most basal Diplostomida are evidently significantly derived in comparison to basal plagiorchiidans. Two equally parsimonious hypotheses for the evolution of life cycle characters in the Diplostomida are shown in Figure 11; numbers below refer to clades labelled in this figure. The hypothesis in Figure 11a proposes the following sequence*:

Plesiomorphic life cycle characters for the Digenea (1–3). As for the Plagiorchiida, this hypothesis commences with the inferences that plesiomorphically the miracidium hatches from eggs outside the host and the fork-tailed cercaria emerges from gastropods to be eaten passively by a teleost definitive host.

Definitive hosts tetrapods (4). In contrast to the Plagiorchiida, all Diplostomida except the blood flukes of fishes (Sanguinicolidae) are parasites of tetrapods.

Molluscan second intermediate host intercalated by cercarial entry into natural pores (5). All Brachylaimoidea have molluscs as second intermediate hosts except where, by abbreviation, the metacercariae form in the first intermediate host (Hasstilesiidae and Leucochloridiidae).

Egg eaten (6). A life cycle apomorphy for the Brachylaimoidea.

Vertebrate second intermediate host intercalated by cercarial penetration (7). Whereas in the Brachylaimoidea the cercaria typically enters molluscs via natural pores, in the remainder of the Diplostomida vertebrates (or rarely other taxa) are penetrated actively and penetration glands are present.

Vertebrate definitive host lost (8). This step of life cycle abbreviation gives rise to the life cycle seen in all three blood fluke families.

*The steps shown here exclude the evolution of the form of the second asexual generation, which is inferred to incorporate several derivations of sporocysts.

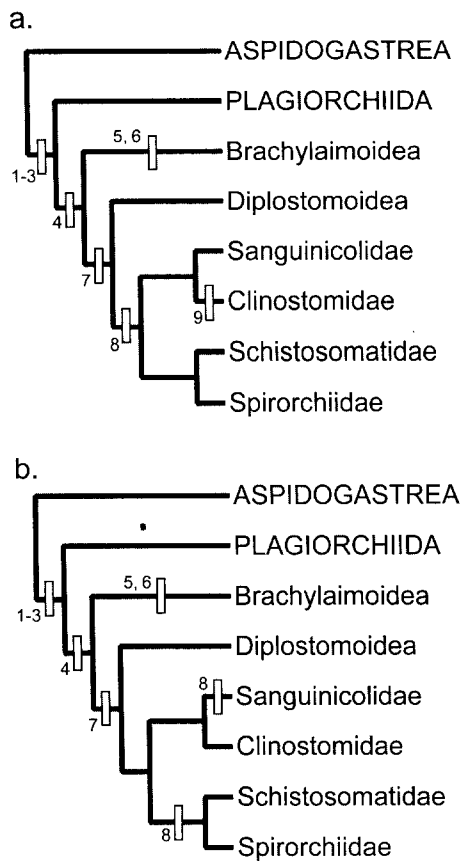

Figure 11 Two hypotheses for the evolution of life cycles within the Diplostomida assuming plesiomorphic ingestion of the cercaria by the definitive host. Numbered evolutionary changes are described in the text.

Vertebrate definitive host added (secondarily) (9). This step hypothesizes the re-extension to a three host life cycle in the Clinostomidae by the secondary addition of a vertebrate definitive host.

A second equally parsimonious hypothesis for the evolution of life cycles within the Diplostomida (Figure 11b) differs from the first by proposing the independent abbreviation of the life cycle by the Sanguinicolidae and the Schistosomatidae + Spirorchiidae (i.e. number 8 appears twice) and no secondary adoption of vertebrate parasitism by the Clinostomidae. The nature of the association between clinostomids and their hosts may allow

discrimination between these two hypotheses. Whereas the other (three-host) Diplostomida are parasites of the intestine, clinostomids are found in the upper digestive tract, typically the oesophagus. This unusual site of infection could be interpreted as being associated with an independent adoption of vertebrates.

There is one substantial difficulty with these hypotheses – the vertebrate host distribution of the Diplostomida. These hypotheses construe the original vertebrate hosts of the Diplostomida to be those in which they presently develop to sexual maturity in three-host life cycles. These hosts are entirely tetrapods, animals associated with the terrestrial habitat in their evolutionary origin, if not necessarily in their present-day ecology. The hosts of the blood flukes, which include fishes, are excluded as original vertebrate hosts because these hypotheses require that they are definitive hosts only by abbreviation of a three-host cycle. It is difficult to infer what such original definitive hosts might have been. Thus, this hypothesis suggests that no extant member of the Diplostomida plesiomorphically develops to adulthood in a fish. Given that we have inferred that the original hosts of digeneans were fishes, this absence must be explained by the extinction of all clades associated with fishes so that only those that coevolved or host-switched into tetrapods remain. Such scenarios are possible, but they seem at best surprising when parasitism of the guts of fishes has proven so successful in the Plagiorchiida. We were able to infer that plagiorchiidans adopted parasitism of tetrapods repeatedly because they have left behind so many traces of these adoptions; in ten of the 11 superfamilies of the Plagiorchiida that occur in tetrapods, there are also representatives in teleost fishes. There are no such traces for the Diplostomida. The Diplostomida might have arisen only as tetrapods appeared but this hypothesis does not seem plausible because the rise of tetrapods is associated with the interface between freshwater and terrestrial environments. This context is inconsistent with the present-day distribution of sanguinicolids which includes marine teleosts, elasmobranchs and holocephalans (Smith, 1997a, b).

An alternative set of hypotheses is suggested by reconsideration of the definitive hosts of the Diplostomida. One taxon, the Sanguinicolidae does occur in fishes and indeed is found in teleosts, elasmobranchs and holocephalans. What are the implications of making the radical assumption that direct penetration as seen in this family was the plesiomorphic cercarial behaviour for the Diplostomida? We here test the hypothesis that the diplostomidan cercaria originally penetrated its definitive host. The hypothesis in Figure 12 proposes the following sequence (the numbers below refer to clades labeled in Figure 12):

Plesiomorphic life cycle characters for the Digenea (1–2). Miracidium hatches from egg outside host (1); cercaria emerges from gastropod (2).

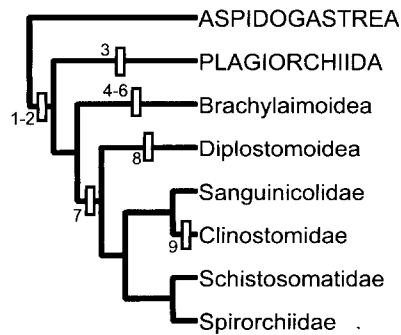

Figure 12 A hypothesis for the evolution of life cycles within the Diplostomida assuming plesiomorphic penetration of the definitive host by the cercaria. Numbered evolutionary changes are described in the text.

(A key distinction relative to the hypotheses in Figure 11 is that ingestion of the cercaria is no longer considered plesiomorphic for the Digenea as a whole but instead a synapomorphy for the Plagiorchiida.)

Cercaria eaten by teleost definitive host (3). This apomorphy serves to define the Plagiorchiida.

Cercaria forms external association with, and enters mollusc; egg eaten by mollusc; tetrapod host added by ingestion of mollusc (4-6). These three apomorphies serve to define the Brachylaimoidea and suggest that they adopted parasitism of vertebrates independently of any other digenean taxon.

Cercaria forms external association with and penetrates vertebrate host (7). This step serves to define the clade of the Diplostomoidea + Schistosomatoidea. Whereas in the Brachylaimoidea the cercaria typically enters the second intermediate host via natural pores, in the remainder of the Diplostomida (Diplostomoidea and Schistosomatoidea) the host is actively penetrated and penetration glands are present. This step is sufficient to establish the nature of blood fluke life cycles.

Vertebrate host added (8-9). The topology here requires the independent extension to three-host life cycles in the Diplostomoidea and the Clinostomidae. The comments made above about the distinctiveness of the association between clinostomids and their vertebrate hosts apply here also.

This hypothesis proposes that the blood fluke life cycle evolved by the direct association of an initially-free-living cercaria with the definitive host. The three-host life cycle then evolved by the addition of a new definitive

host. This host was adopted by the process of a vertebrate ingesting the initial definitive host (= 'host-succession extension' of Sprent (1983) and 'terminal addition' of O'Grady (1985)); throughout the Diplostomida where the life cycle has three hosts the definitive host ingests an intermediate host. The hypothesis notably requires three separate adoptions of vertebrates by the Digenea. Although other equally parsimonious hypotheses are possible (e.g. a single adoption of vertebrate parasitism by the Diplostomoidea + Schistosomatoidea and two abbreviations to blood fluke life cycles) this suffices to illustrate the possibilities of dramatically different interpretation.

This hypothesis requires nine steps of modification, the same as those shown in Figure 11. The main attraction of this hypothesis is that it provides a superior explanation of the apparent restriction of diplostomidans to tetrapods by suggesting that the former are not restricted to the latter at all. The hosts penetrated by diplostomidan cercariae are aquatic. The Leucochloridiomorphae (Brachylaimoidea) have aquatic molluscs as intermediate hosts and the Diplostomoidea and Schistosomatoidea penetrate aquatic vertebrates; a few Diplostomoidea penetrate Annelida and Mollusca. The hosts of Schistosomatidae may not be strictly aquatic, but certainly they are infected while they are in water. The only exception to the penetration of aquatic hosts by cercariae is that part of the clade of the Brachylaimoidea that has become entirely terrestrial. So, if the host penetrated by the cercaria is interpreted as the original definitive host (rather than the actual present-day definitive host), then the range of hosts is plesiomorphically fully aquatic. Such a distribution is exactly what would be predicted for one of two basal clades of the Digenea, a group that is inferred to be a fundamentally aquatic group of parasites and in strong contrast to the tetrapod-only distribution implied by the hypotheses shown in Figure 11.

Although this "cercaria penetrates" hypothesis accounts for some aspects of the host distribution of the Diplostomida, it has three substantial difficulties in terms of intuitive plausibility. First, the hosts penetrated by the Brachylaimoidea are molluscs, whereas the rest of the clade infects mainly vertebrates. This hypothesis suggests that molluscs were once the definitive hosts of this clade. Is such an idea plausible? Jamieson (1966) discussed hypotheses proposing exactly this evolutionary scenario, but certainly no such life cycles are now extant (except perhaps by secondary reduction).

The second difficulty associated with the "cercaria penetrates" hypothesis is that it requires that a free-living adult (the proto-cercaria of Pearson, 1972) evolved into one that, for the Diplostomoidea + Schistosomatoidea, penetrated a vertebrate host and developed to a sexual adult capable of releasing its eggs while leaving no evolutionary trace of the process. This

involves significant conceptual complexity. The evolution of penetration in the Brachylaimoidea is relatively easily envisaged. Their cercariae typically enter the excretory pore of another mollusc and then develop as unencysted metacercariae in the excretory vesicle or other cavities to which they migrate. Such behaviour might have arisen gradually following the formation of an external association with the mollusc. Further, this form of parasitism does not require penetration glands or the evolution of a mechanism for the escape of the eggs of the parasite. Because the Brachylaimoidea is basal to the remainder of the Diplostomida, this simple behaviour might have given rise to the more sophisticated penetration behaviours of the remainder of the clade. However, there remains a major gulf between the unsophisticated behaviour of the brachylaimoids and the sophisticated penetration of the remainder of the Diplostomida. In addition, the use of nearly completely exclusive second intermediate host groups (molluscs for Brachylaimoidea and vertebrates for Diplostomoidea + Schistosomatoidea) implies either a dramatic host-switch or independent derivation (as shown in Figure 12).

The third difficulty returns to the host distribution for the Diplostomida. If two-host blood fluke life cycles gave rise to three-host cycles, then why are none of these additions found in fishes?

The hypothesis in Figure 12 is radical in proposing that digeneans adopted vertebrate parasitism three times. Other hypotheses are possible that require fewer vertebrate host adoptions by proposing host switches (especially of the second intermediate host). It should be noted, however, that the interpretation of the evolution of the Plagiorchiida also raised the possibility that the Transversotrematidae had an adoption of vertebrate hosts separate from the remainder of that clade. The significance of this is that one of our underlying inferences from outgroup comparison with the Aspidogastrea may have been false. That is, although aspidogastreans and digeneans both share molluscs and vertebrates as alternating hosts, the two life cycles may be only partly homologous. This potential difficulty was predicted, in part, when we drew attention to the number of differences between the nature of the aspidogastrea and digenean life cycles. Finally in this context we must note that the hypotheses in Figures 11 and 12 are equally parsimonious only if the analysis is restricted to the Digenea; if the Aspidogastrea are incorporated then strict parsimony favours the hypotheses in Figure 11. We return to a general consideration of such issues in Section 5.2 (p. 241).

The evolution of life cycles within the Diplostomida thus remains poorly understood. The most basal taxa have complex, highly derived life cycles and several equally parsimonious hypotheses are presently tenable to explain them. We cannot yet discriminate satisfactorily between them.

5. PROBLEMS

5.1. Shortcomings of the Parsimony Approach

Whereas we are confident that the parsimony approach we have taken above has conceptual rigour and in some cases provides excellent insight, we are certainly aware that it is not infallible. There are two conceptual problems. The first relates to the underlying phylogeny. Even if we assume that the phylogeny is broadly correct, we can be certain that many highly informative taxa are extinct. The problem is illustrated in Figure 13(a) which shows the "true" relationships between a hypothetical outgroup (X) and four ingroup taxa (A–D). The mapping of four character states (1–4) on the five taxa allows an unambiguous interpretation of the pattern of evolution of the four character states. Figure 13(b) shows the "true" relationships of five descendants of taxon D and proposes that taxa A–C are extinct. If we

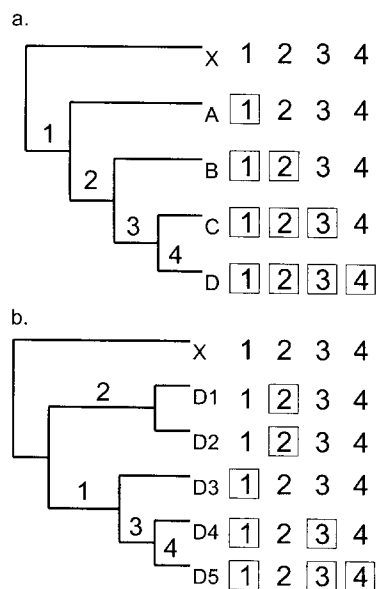

Figure 13 Problems of false inference in parsimony analysis. a. 'True' relationships of a hypothetical outgroup (X) and an ingroup (A–D) allowing inference of the pattern of derivation of four characters (1–4; derived states boxed). b. 'True' relationships of outgroup (X) and ingroup (D1–D5) following extinction of taxa A–C. Parsimonious analysis falsely suggests that all four derived character states arose within D.

refer to the "true" pattern of evolution of the characters, then we see that all four have been subject to some secondary loss in the clade of taxon D's descendants. However, without knowledge of taxa A-C this is unknowable. Relying on parsimony to interpret the evolution of these characters leads to mistakes in every case; we would conclude that all four derived character states arose within the clade of D. This type of problem is potentially significant in analysis of the Digenea. All digeneans have a highly complex life cycle that has many complex features not found in the sister taxon (Aspidogastrea; see below). It is reasonable to assume that forms that were in some way once intermediate between the Digenea and Aspidogastrea are now extinct. If such forms were incorporated in the phylogeny the possibility of false inferences would be reduced. In a sense, however, this observation simply restates the underlying problem: if all ancestors and extinct taxa were available for study, then the path of evolution would be clear. This exercise emphasizes the facts that objective parsimony analysis may easily support false hypotheses and that the evolutionary history of particular life cycle traits may be unknowable.

A second problem flows from the first. If there is no guarantee that a parsimoniously derived hypothesis is necessarily true, is there a way in which we can discover the truth? If parsimony analysis leaves us with a hypothesis that is actually false, we suspect that the error can be detected only if it is first deemed to be intuitively unsatisfactory and is thus subjected to further scrutiny. In our view, the inference of a parsimonious but unsatisfying hypothesis should quite reasonably be taken as the spur for further consideration of the underlying data, ideally with the goal of either finding further objective mappable evidence or exploring the homology of the existing characters. This is logical, but methodologically dangerous. The decision that a parsimoniously derived hypothesis is "unsatisfying" carries the implication that the analyst has preconceived ideas of the "true" answer. Such preconceptions (insights or bias?) can lead to the "adjustment" or "development" of the data and repeated analysis until the "correct" result is found. Such an approach has the capacity to lead to the support of a false hypothesis just as easily as can the uncritical acceptance of parsimonious hypotheses. In essence, it is difficult for the analyst to remain both interested and disinterested and passionate and dispassionate.

5.2. Conflict between Hypotheses

Analysis of the evolution of life cycles in the Digenea creates exactly the kind of problems that we have described above. In our analysis we largely

avoided addressing a substantial problem that bears on much of the analysis above – how did the basic digenean life cycle evolve? The problem that we have avoided is easily described. The topology of the Platyhelminthes as a whole, and the position of the Neodermata (Figure 2) allow the parsimonious interpretation that neodermatans as a whole adopted parasitism of vertebrates. This hypothesis suggests that, subsequently, the Trematoda adopted molluscs as second intermediate hosts. It is parsimonious to propose then that the initial digenean two-host cycle resembled that of present-day aspidogastreans as described earlier.

Two difficulties are posed by this hypothesis. First, it implies that vertebrates were adopted just once by the ancestors of the Neodermata; parsimony suggests that all present-day associations can be explained by coevolution or host-switching, not the separate adoption of vertebrates *de novo*. However, the hypotheses developed above may imply separate adoption of vertebrates, at least by the Diplostomida and the Plagiorchiida. More extravagant hypotheses, which are not without support, might suggest even more adoptions. First in the list of candidates for independent adoption of vertebrates might well be the Transversotrematidae.

The second problem relates to the evolution of the cercaria. Parsimonious interpretation of the topology of the Neodermata suggests that the digenean life cycle arose from an aspidogastreaan-style cycle. The difficulty with this is that, in the Aspidogastrea, infection of the definitive host occurs by ingestion of the mollusc. By contrast, our analysis of cercarial behaviour allows the unambiguous conclusion that for extant Digenea the cercaria plesiomorphically emerged from the mollusc. An overall analysis of the Neodermata suggests that an aspidogastreaan-style life cycle gave rise to a digenean cycle in which the cercaria emerged from the mollusc. However, there is no compelling narrative to describe how this might have occurred. Hypotheses for the Digenea such as that of Pearson (1972) suggested that cercarial emergence occurred in the context of a mollusc-only life cycle. This idea makes it relatively easy to postulate hypotheses in which some of the distinctive vertebrate infection strategies of the Diplostomida and the Plagiorchiida were derived independently.

Thus, objective parsimony analysis of the major taxa of Neodermata suggests one set of hypotheses whereas analysis of the Trematoda in isolation suggests quite different hypotheses. In principle, the resolution of the problem should occur by way of an expanded analysis that incorporates more taxa and more objectively mappable characters, if extant taxa have sufficiently retained the evolutionary markers. In practice, however, the task is formidable; present analyses rely on more than a century of accumulated study of digenean life cycles. The truth here may well be unknowable.

5.3. Ten Questions

We believe that substantial progress is being made in the understanding of the evolution of the digenean life cycle. However, many questions remain to be answered. Below we pose ten questions that we consider both important and unanswered, but potentially answerable when incorporated in the approach espoused herein.

- (i) What, if anything, is homologous between the aspidogastreaan and digenean life cycles? An answer to this question should address two related issues: Is the infection of molluscs in the two groups truly homologous? Did the Trematoda as a whole inherit parasitism of vertebrates from a single neodermatan adoption of vertebrate parasitism?
- (ii) Has any major clade of digeneans coevolved (in the sense of strict cophyly with little or no host-switching) with molluscan first intermediate hosts?
- (iii) How did life cycles within the Diplostomida arise, and are their origins linked to the appearance of tetrapods?
- (iv) Why are the Sanguinicolidae uniquely found in gastropods, bivalves and polychaetes as first intermediate hosts and holocephalans, chondrichthyans and teleosts as definitive hosts?
- (v) Why are digeneans conspicuously rare in chondrichthyans?
- (vi) Why do the Bivesiculidae lack oral and ventral suckers?
- (vii) How did the life cycle of the Transversotrematidae arise?
- (viii) Why have the Paramphistomata lost their oral suckers?
- (ix) What is the significance of the correlation between the infection of bivalves and the presence of sporocysts?
- (x) What was the chronology of the evolution of the digenean life cycle?

If these questions are answered with evidence that is both objective and compelling, the evolution of the digenean life cycle may be considered well-understood. Answers to some of the questions have been inferred herein, but should certainly be subject to further scrutiny. Other questions require further descriptive work. We are by no means beyond the age of information gathering; for a number of intriguing digenean families there is no life cycle information at all and for many it is inadequate. For some of the questions we may already have all the information that can be gathered. Some questions may prove unanswerable based on evidence stemming from extant taxa.

Analysis of the evolution of life cycles should occur at many different levels within a phylogenetic framework. For example, we note

inconsistencies when the phylogeny of the Neodermata and the Digenea are considered separately. Such inconsistencies are informative in that they demand further work and illumination. Detailed analyses of smaller clades (e.g. superfamilies) will minimize the need to make assumptions about more inclusive clades (e.g. orders) and will provide a better understanding of both plasticity and conservation in the evolution of digenean life cycles. Moreover, new phylogenies with even greater representation of digenean diversity will extend our ability to infer the sequence, acquisition and loss of life cycle traits. We hope that our efforts will go some way in guiding workers who wish to elucidate the evolution of parasite life cycles within other taxa.

APPENDIX

Summary of key life cycle characteristics of major taxa of the Digenea discussed in this review. Taxa are listed in the order shown in the figures

Order Diplostomida

Brachylaimoidea. This superfamily comprises mainly families that have entirely terrestrial life cycles (*Brachylaimidae*, *Hasstilesiidae* and *Leucochloridiidae*) and the *Leucochloriodiomorphidae* which has an aquatic cycle. In the *Leucochloriodiomorphidae* fork-tailed cercariae emerge from freshwater snails and enter other molluscs in which they form metacercariae; the molluscs are eaten to complete the life cycle (Allison, 1945). In the *Brachylaimidae* almost tail-less cercariae leave the terrestrial gastropod and enter another gastropod where they form metacercariae (Mas-Coma and Montoliu, 1986). In the *Hasstilesiidae* and *Leucochloridiidae* (Bakke, 1980) the life cycle is two-host, the cercariae forming metacercariae in the snail in which they are produced. The egg must be ingested by the gastropod.

Diplostomoidea. This superfamily comprises six families (*Diplostomidae*, *Strigeidae*, *Brauninidae*, *Bolbocephalodidae*, *Cyathocotylidae*, *Proterodiplostomidae*) (Niewiadomska, 2002) all of which occur as adults in tetrapods only. The life cycle is highly uniform. Fork-tailed cercariae are produced in sporocysts in gastropods. These penetrate and form metacercariae especially in fishes and amphibians but also in molluscs and annelids (Pearson, 1961). In some *Diplostomidae* the life cycle is expanded to incorporate four hosts by the intercalation of a mesocercaria (a form

between the cercaria and the metacercaria) (Pearson, 1956). Eggs typically hatch and penetrate the first intermediate host.

Schistosomatoidea. This superfamily comprises all the blood flukes (Sanguinicolidae, Schistosomatidae and Spirorchiidae) and the Clinostomidae. Kanev *et al.* (2002) include the Clinostomidae and Liolopidae in a separate superfamily, the Clinostomoidea. The relationship of clinostomids and liolopids has not been confirmed by molecular evidence and almost nothing is known of liolopid life cycles. In the Schistosomatoidea as conceived here fork-tailed cercariae are produced in rediae or sporocysts in gastropods, bivalves or polychaetes and penetrate their definitive hosts directly in the case of the blood flukes (Wall, 1951; Køie, 1982; Blair and Islam, 1983) or enter fishes or amphibians in which metacercariae form in the case of the Clinostomidae (Dönges, 1974). Eggs typically hatch and penetrate the first intermediate host.

Order PLAGIORCHIIDA

Bivesiculoidea. This superfamily includes only the Bivesiculidae, and is the most basal clade in the Plagiorchiida. It comprises about 30 species of digeneans that occur as sexual adults in the small intestine of fishes. Fork-tailed cercariae are produced in rediae in gastropods. After emergence from the snail the body is withdrawn into the base of the tail; the cercaria then awaits consumption by the definitive host (Cable and Nahhas, 1962; Pearson, 1968; Cribb *et al.*, 1998). In one cycle it has been shown that a fish intermediate host may be intercalated (Cribb *et al.*, 1998). Eggs typically hatch and penetrate the first intermediate host.

Transversotrematoidea. This superfamily includes only the Transversotrematidae, a tiny family of about 10 species found under the scales of marine and freshwater fish in the Indo-Pacific region. Their unique and highly modified fork-tailed cercariae are produced in rediae in gastropods and attach directly to the definitive host (Cribb, 1988). Eggs typically hatch and penetrate the first intermediate host.

Azygioidea. This superfamily includes only the Azygiidae which are parasitic in marine and freshwater fishes. Their life cycle is essentially identical to that of the Bivesiculidae in that fork-tailed cercariae are produced in rediae in gastropods, the cercarial body is withdrawn into the tail after emergence, and the definitive host is infected by ingesting the cercaria directly (Sillman, 1962). Some cycles are known in which cercariae emerge with eggs already formed in the uterus (Dickerman, 1946). In many cycles (especially those leading to infection of elasmobranchs) a second

intermediate host is apparently intercalated in the life cycle (Brinkmann, 1988). The egg must be ingested by the gastropod.

Hemiuroidea. This superfamily comprises 12 families (Gibson, 2002) and the Didymozoidae and it is one of the major clades of digeneans parasitic in marine and freshwater fishes (a few have entered tetrapods). Their life cycles feature a specialized fork-tailed cercaria known as a cystophorous cercaria. These are produced in sporocysts or rediae in gastropods and very rarely in scaphopods or bivalves. When cystophorous cercariae are eaten by the second intermediate host (which may well always be an arthropod), a specialized structure, the delivery tube, everts, penetrates the host's gut and injects the cercarial body into the haemocoel of the arthropod where an unencysted metacercaria forms (Køie, 1990). These are then transmitted to the definitive host by ingestion. A number of hemiuroid life cycles have been extended to four hosts by the intercalation of an extra host between the second intermediate and definitive hosts (Madhavi, 1978; Goater *et al.*, 1990). The life cycle may also be abbreviated; Jamieson (1966) reported a cycle in which all stages were found within the gastropod. The egg must be ingested by the gastropod.

Heronimoidea. This superfamily includes only the Heronimidae which is itself represented by a single species, *Heronimus chelydrae*, which lives in the lungs of freshwater turtles in North America. Simple-tailed cercariae are produced in a massive branched sporocyst in gastropods. The cercariae do not emerge from the snail host, but are eaten with the snail by the turtle (Crandall, 1960). The egg hatches and the miracidium penetrates the first intermediate host.

Bucephaloidea. This superfamily contains only one family, the Bucephalidae, which is a major clade parasitic almost exclusively in the intestines of teleost fishes. Distinctive fork-tailed cercariae emerge from branching sporocysts in bivalves and penetrate fishes in which they form metacercariae which are transmitted by ingestion to other fishes (Matthews, R.A., 1974). Miracidia typically hatch and penetrate the first intermediate host.

Gymnophalloidea. This superfamily comprises the Gymnophallidae of birds and the Botulisaccidae, Callodistomidae, Fellodistomidae and Tandanicolidae and fishes. Nothing is known of the life cycles of the Botulisaccidae and Callodistomidae. All known gymnophalloids use bivalves as first intermediate hosts and have fork-tailed cercariae that emerge from sporocysts. The simplest cycles are seen in the Tandanicolidae and some Fellodistomidae in which the cercariae are eaten directly by the definitive host (Angel, 1971; Køie, 1980). In some Fellodistomidae and all known Gymnophallidae the cercariae are eaten by or penetrate a range of second intermediate hosts in which a

metacercaria forms (Campbell, 1985). Miracidia typically hatch and penetrate the first intermediate host.

Paramphistomoidea. This superfamily is a major radiation of up to 12 families found principally in teleosts, amphibians, reptiles and mammals. Cercariae are simple-tailed and produced in rediae in gastropods. Cercariae emerge from the gastropod and encyst in the open. Encystment is typically on vegetation or on hard surfaces of food (e.g. gastropods) that is eaten by definitive host (Durie, 1956). The life cycle never involves a true second intermediate host. Miracidia typically hatch and penetrate the first intermediate host.

Pronocephaloidea. This superfamily is a major radiation of six families found in all classes of vertebrates except chondrichthyans. Cercariae are simple-tailed and produced in redia in gastropods. They emerge to encyst in the open, typically on vegetation or on hard surfaces of food (e.g. gastropods) that is eaten by definitive host (Martin, 1956). The life cycle never involves a true second intermediate host. The life cycle differs materially from that of the Paramphistomoidea only in the miracidium, which must be eaten by the gastropod host whereupon a mechanical structure injects it into the body cavity of the host.

Haploplanchnoidea. This superfamily contains only its type-family, trematodes parasitic in the intestines of marine herbivorous fishes. Few life cycles have been elucidated for the family but it appears that simple-tailed cercariae are produced in sporocysts in gastropods and emerge to encyst in association with algae to be eaten subsequently by the definitive host (Cable, 1954). Miracidia typically hatch and penetrate the first intermediate host externally.

Echinostomatoidea. This superfamily is a major clade comprising mainly families parasitic in tetrapods. Cercariae are simple-tailed and produced in rediae in gastropods. The cercariae may encyst in the first intermediate host (Cyclocoelidae) (Johnston and Simpson, 1940), encyst in the open (Fasciolidae, some Philophthalmidae, Psilostomidae and Echinostomatidae) (Cable, 1954; Howell and Bearup, 1967) or in association with or inside second intermediate hosts (usually molluscs or vertebrates - some Psilostomidae and Echinostomatidae) (Johnston and Angel, 1942). Miracidia typically hatch and penetrate the first intermediate host.

Opisthorchioidea. This superfamily comprises three main families, the Cryptogonimidae, Opisthorchiidae and Heterophyidae. They are parasites of teleosts, reptiles, birds and mammals. Simple-tailed cercariae are produced in rediae in gastropods and emerge to penetrate fishes (rarely amphibians) in which a metacercaria develops (Bearup, 1961; Cribb, 1986). The egg must be ingested by the gastropod.

Apocreadioidea. This superfamily contains only the Apocreadiidae which are parasites of the intestines of marine and freshwater teleost fishes. Few life cycles are known. Typically, simple-tailed cercariae are produced in rediae with in gastropods. These cercariae emerge to penetrate and encyst in molluscs and annelids which are eaten by the definitive host (Stunkard, 1964). Miracidia typically hatch and penetrate the first intermediate host externally.

Lepocreadioidea. This superfamily comprises a major assemblage of perhaps nine families of trematodes overwhelmingly parasitic in teleosts. Cercariae are always simple-tailed and almost always infect a second intermediate host. First intermediate hosts are gastropods in which rediae occur. Cercariae penetrate a wide range of phyla of invertebrates and rarely fishes in which a metacercaria develops (Køie, 1975; Watson, 1984; Køie, 1985). Life cycles are completely unknown for Gorgocephalidae, Enenteridae and Gyliuchenidae. Miracidia typically hatch and penetrate the first intermediate host.

Monorchioidae. This superfamily includes parasites of marine and freshwater fishes in the families Monorchiidae and Lissorchiidae. Monorchiidae produce cercariae in sporocysts in bivalves (Bartoli *et al.*, 2000) whereas Lissorchiidae produce cercariae in both rediae and sporocysts in gastropods (Stunkard, 1959). Second intermediate hosts are a wide range of invertebrates. It appears that typically eggs must be eaten by the first intermediate host.

Xiphidiata. The Xiphidiata is a huge clade parasitic in all classes of vertebrates except chondrichthyans. The classification proposed by Olson *et al.* (2003) recognizes four superfamilies: Allocreadioidea, Gorgoderioidea, Microphalloidea and Plagiorchioidea. Overall, life cycles within this clade are characterized by simple-tailed cercariae that have a stylet, emerge from gastropods, and penetrate arthropod second intermediate hosts; this life cycle is found in all four superfamilies (Yamaguti, 1943; Johnston and Angel, 1951; Stunkard, 1968; Prévôt *et al.*, 1976). There are many important variations. First intermediate hosts are bivalves for the Allocreadiidae, Gorgoderidae and Faustulidae (Thomas, 1958; Chun and Kim, 1982). Both rediae and sporocysts are common in the Gorgoderioidea whereas sporocysts are overwhelmingly dominant in the other three superfamilies. Some families, notably the Haploporidae which also has no second intermediate host, lack stylets (Shameem and Madhavi, 1991). Metacercaria are formed most frequently in arthropods but occur in almost any animal. The extent to which these variations are genuine within-clade variation or may reflect weaknesses in the current classification and phylogeny is not clear. Cercariae may encyst within first intermediate hosts (all Eucotylidae, some Microphallidae,

Opecoelidae and others). Miracidia may hatch or await ingestion of the egg.

ACKNOWLEDGEMENTS

T.H.C. is supported by grants from the Australian Research Council and the Australian Biological Resources Study. P.D.O. and D.T.J.L. are supported by a Wellcome Trust Senior Research Fellowship (043965) to D.T.J.L. We thank Trudy Wright for gathering and assembling much of the life cycle data analysed here.

REFERENCES

- Allison, L.N. (1945). *Leucochloridiomorpha constantiae* (Mueller) (Brachylaimidae), its life cycle and taxonomic relationships among digenetic trematodes. *Transactions of the American Microscopical Society* **62**, 127–168.
- Angel, L.M. (1967). The life-cycle of *Echinoparyphium hydromyos* sp. nov. (Digenea: Echinostomatidae) from the Australian water-rat. *Parasitology* **57**, 19–30.
- Angel, L.M. (1971). *Burnellus* gen. nov. (Digenea: Fellodistomatidae), the life history of the type-species, *B. trichofurcatus* (Johnston & Angel, 1940), and a note on a related species, *Tandanicola bancrofti* Johnston, 1927, both from the Australian freshwater catfish, *Tandanus tandanus*. *Parasitology* **62**, 375–384.
- Bakke, T.A. (1980). A revision of the family Leucochloridiidae Poche (Digenea) and studies on the morphology of *Leucochloridium paradoxum* Carus, 1835. *Systematic Parasitology* **1**, 189–202.
- Barker, S.C. and Cribb, T.H. (1993). Sporocysts of *Mesostephanus haliasturis* (Digenea) produce miracidia. *International Journal for Parasitology* **23**, 137–139.
- Bartoli, P., Jousson, O. and Russell-Pinto, F. (2000). The life cycle of *Monorchis parvus* (Digenea: Monorchiiidae) demonstrated by developmental and molecular data. *Journal of Parasitology* **86**, 479–489.
- Bearup, A.J. (1961). Observations on the life cycle of *Stictodora lari* (Trematoda: Heterophyidae). *Proceedings of the Linnean Society of New South Wales* **86**, 251–257.
- Blair, D. and Islam, K.S. (1983). The life-cycle and morphology of *Trichobilharzia australis* n. sp. (Digenea: Schistosomatidae) from the nasal blood vessels of the black duck (*Anas superciliosa*) in Australia, with a review of the genus *Trichobilharzia*. *Systematic Parasitology* **5**, 89–117.
- Bray, R.A. & Cribb, T.H. (2003). The digeneans of elasmobranchs – distribution and evolutionary significance. In: *Taxonomie, écologie et évolution des métazoaires parasites* (C. Combes and J. Jourdain, eds). Tome I, 67–96. Perpignan: Presses Universitaire de Perpignan.

- Bray, R.A., Gibson, D.I. and Zhang, J. (1999). Urotrematidae Poche, 1926 (Platyhelminthes: Digenea) in Chinese freshwater fishes. *Systematic Parasitology* **44**, 193–200.
- Brinkmann, A. (1988). Presence of *Otodistomum* sp. metacercariae in Norwegian marine fishes. *Sarsia* **73**, 79–82.
- Brooks, D.R. and Bandoni, S.M. (1988). Coevolution and relicts. *Systematic Zoology* **37**, 19–33.
- Brooks, D.R., O'Grady, R.T. and Glen, D.R. (1985). Phylogenetic analysis of the Digenea (Platyhelminthes: Cercomeria) with comments on their adaptive radiation. *Canadian Journal of Zoology* **63**, 411–443.
- Brooks, D.R., Bandoni, S.M., MacDonald, C.A. and O'Grady, R.T. (1989). Aspects of the phylogeny of the Trematoda Rudolphi, 1808 (Platyhelminthes: Cercomeria). *Canadian Journal of Zoology* **67**, 2609–2624.
- Cable, R.M. (1954). Studies on marine digenetic trematodes of Puerto Rico. The life cycle in the family Haplospilachnidae. *Journal of Parasitology* **40**, 71–76.
- Cable, R.M. (1974). Phylogeny and taxonomy of trematodes with reference to marine species. In: *Symbiosis in the Sea* (W.B. Vernberg, ed.), pp. 173–193. Columbia, South Carolina: University of South Carolina Press.
- Cable, R.M. (1982). Phylogeny and taxonomy of the malacobothrean flukes. In: *Parasites – their world and ours* (D.F. Mettrick and S.S. Desser, eds), pp. 194–197. Amsterdam: Elsevier Biomedical Press.
- Cable, R.M. and Nahhas, F.M. (1962). *Bivesicula caribbensis* sp. n. (Trematoda: Digenea) and its life history. *Journal of Parasitology* **48**, 536–538.
- Caira, J.N. (1989). A revision of the North American papillose Allocreadiidae (Digenea) with independent cladistic analyses of larval and adult forms. *Bulletin of The University of Nebraska State Museum* **11**, 1–91.
- Campbell, D. (1985). The life cycle of *Gymnophallus rebecqui* (Digenea: Gymnophallidae) and the response of the bivalve *Abra tenuis* to its metacercariae. *Journal of the Marine Biological Association of the United Kingdom* **65**, 589–601.
- Chun, S.K. and Kim, Y.G. (1982). [Studies on the life history of the trematode parasitic in *Meretrix lusoria* Röding]. *Bulletin of National Fisheries University of Busan* **22**, 31–44.
- Crandall, R.B. (1960). The life history and affinities of the turtle lung fluke, *Heronimus chelydrae* MacCallum, 1902. *Journal of Parasitology* **46**, 289–307.
- Cribb, T.H. (1986). The life cycle and morphology of *Stemmatostoma pearsoni*, gen. et sp. nov., with notes on the morphology of *Telogaster opisthorchis* Macfarlane (Digenea: Cryptogonimidae). *Australian Journal of Zoology* **34**, 279–304.
- Cribb, T.H. (1988). Life cycle and biology of *Prototransversotrema steeri* Angel, 1969 (Digenea: Transversotrematidae). *Australian Journal of Zoology* **36**, 111–129.
- Cribb, T.H., Anderson, G.R., Adlard, R.D. and Bray, R.A. (1998). A DNA-based demonstration of a three-host life-cycle for the Bivesiculidae (Platyhelminthes: Digenea). *International Journal for Parasitology* **28**, 1791–1795.
- Cribb, T.H., Bray, R.A., Littlewood, D.T.J., Pichelin, S. and Herniou, E.A. (2001). The Digenea. In: *Interrelationships of the Platyhelminthes* (D.T.J. Littlewood and R.A. Bray, eds), pp. 168–185. London: Taylor & Francis.
- Cribb, T.H., Chisholm, L.A. and Bray, R.A. (2002). Diversity in the Monogenea and Digenea: does lifestyle matter? *International Journal for Parasitology* **32**, 321–328.
- Dickerman, E.E. (1946). Studies on the trematode family Azygiidae. III. The morphology and life cycle of *Proterometra sagittaria* n. sp. *Transactions of the American Microscopical Society* **65**, 37–44.

- Dönges, J. (1971). The potential number of redial generations in echinostomatids (Trematoda). *International Journal for Parasitology* **1**, 51–59.
- Dönges, J. (1974). The life cycle of *Euclinostomum heterostomum* (Rudolphi, 1809) (Trematoda: Clinostomatidae). *International Journal for Parasitology* **4**, 79–90.
- Durie, P.H. (1956). The paramphistomes (Trematoda) of Australian ruminants III. The life-history of *Calicophoron calicophorum* (Fischöeder) Nasmark. *Australian Journal of Zoology* **4**, 152–157.
- Ferguson, M.A., Cribb, T.H. and Smales, L.R. (1999). Life-cycle and biology of *Sychnocotyle kholo* n. g., n. sp. (Trematoda: Aspidogastrea) in *Emydura macquarii* (Pleurodira: Chelidae) from southern Queensland, Australia. *Systematic Parasitology* **43**, 41–48.
- Gibson, D.I. (1987). Questions in digenean systematics and evolution. *Parasitology* **95**, 429–460.
- Gibson, D.I. (2002). Superfamily Hemiuroidea Looss, 1899. In: *Keys to the Trematoda* (D.I. Gibson, A. Jones and R.A. Bray, eds), Vol. 1, pp. 299–413. Wallingford and New York: CABI Publishing.
- Gibson, D.I. and Bray, R.A. (1986). The Hemiuridae (Digenea) of fishes from the north-east Atlantic. *Bulletin of the British Museum (Natural History) Zoology* **51**, 1–125.
- Gibson, D.I., Jones, A. and Bray, R.A., eds (2002). *Keys to the Trematoda*. Vol. 1. Wallingford and New York: CABI Publishing.
- Goater, T.M., Browne, C.L. and Esch, G.W. (1990). On the life history and functional morphology of *Halipegus occidualis* (Trematoda: Hemiuridae), with emphasis on the cystophorous cercaria stage. *International Journal for Parasitology* **20**, 923–934.
- Hall, K.A., Cribb, T.H. and Barker, S.C. (1999). V4 region of small subunit rDNA indicates polyphyly of the Fellodistomidae (Digenea) which is supported by morphology and life-cycle data. *Systematic Parasitology* **43**, 81–92.
- Howell, M.J. and Bearup, A.J. (1967). The life histories of two bird trematodes of the family Philophthalmidae. *Proceedings of the Linnean Society of New South Wales* **92**, 182–194.
- Huelsenbeck, J.P., Ronquist, F., Nielsen, R. and Bollback, J.P. (2001). Bayesian inference of phylogeny and its impact on evolutionary biology. *Science* **294**, 2310–2314.
- Jamieson, B.G.M. (1966). Larval stages of the progenetic trematode *Parahemiurus bennettiae* Jamieson, 1966 (Digenea, Hemiuridae) and the evolutionary origin of cercariae. *Proceedings of the Royal Society of Queensland* **77**, 81–91.
- Johnston, T.H. and Angel, L.M. (1942). The life history of the trematode, *Paryphostomum tenuicollis* (S. J. Johnston). *Transactions of the Royal Society of South Australia* **66**, 119–123.
- Johnston, T.H. and Angel, L.M. (1951). The life history of *Plagiorchis jaenschi*, a new trematode from the Australian water rat. *Transactions of the Royal Society of South Australia* **74**, 49–58.
- Johnston, T.H. and Simpson, E.R. (1940). The anatomy and life history of the trematode *Cyclocoelium jaenschi* n. sp. *Transactions of the Royal Society of South Australia* **64**, 273–278.
- Jue Sue, L. and Platt, T.R. (1998). Description and life-cycle of two new species of *Choanocotyle* n. g. (Trematoda: Plagiorchiida), parasites of Australian freshwater turtles, and the erection of the family Choanocotylidae. *Systematic Parasitology* **41**, 47–61.

- Kanev, I., Radev, V. and Fried, B. (2002). Superfamily Clinostomoidea Lühe, 1901. In: *Keys to the Trematoda* (D.I. Gibson, A. Jones and R.A. Bray, eds). Vol. 1, pp. 111–125. Wallingford and New York: CABI Publishing.
- Kearn, G.C. (1998). *Parasitism and the Platyhelminths*. London & New York: Chapman & Hall.
- Køie, M. (1975). On the morphology and life-history of *Opechona bacillaris* (Molin, 1859) Looss, 1907 (Trematoda, Lepocreadiidae). *Ophelia* **13**, 63–86.
- Køie, M. (1979). On the morphology and life-history of *Monascus* [= *Haplocladus*] *filiformis* (Rudolphi, 1819) Looss, 1907 and *Steringophorus furciger* (Olsson, 1868) Odhner, 1905 (Trematoda, Fellodistomidae). *Ophelia* **18**, 113–132.
- Køie, M. (1980). On the morphology and life-history of *Steringotrema pagelli* (Van Beneden, 1871) Odhner, 1911 and *Fellodistomum felis* (Olsson, 1868) Nicoll, 1909 [syn. *S. ovacautum* (Lebour, 1908) Yamaguti, 1953] (Trematoda, Fellodistomidae). *Ophelia* **19**, 215–236.
- Køie, M. (1982). The redia, cercaria and early stages of *Aporocotyle simplex* Odhner, 1900 (Sanguinicolidae) – a digenetic trematode which has a polychaete annelid as the only intermediate host. *Ophelia* **21**, 115–145.
- Køie, M. (1985). On the morphology and life-history of *Lepidapedon elongatum* (Lebour, 1908) Nicoll, 1910 (Trematoda, Lepocreadiidae). *Ophelia* **24**, 135–153.
- Køie, M. (1990). On the morphology and life-history of *Hemiurus luehei* Odhner, 1905 (Digenea: Hemiuridae). *Journal of Helminthology* **64**, 193–202.
- Køie, M., Karlsbakk, E. and Nylund, A. (2002). A cystophorous cercaria and metacercaria in *Antalis entalis* (L.) (Mollusca, Scaphopoda) in Norwegian waters, the larval stage of *Lecithophyllum botryophorum* (Olsson, 1868) (Digenea, Lecithasteridae). *Sarsia* **87**, 302–311.
- La Rue, G.R. (1951). Host-parasite relations among the digenetic trematodes. *Journal of Parasitology* **37**, 333–342.
- Lim, H.K. and Heyneman, D. (1972). Intramolluscan inter-trematode antagonism: a review of factors influencing the host-parasite system and its possible role in biological control. *Advances in Parasitology* **10**, 191–268.
- Littlewood, D.T.J., Rohde, K., Bray, R.A. and Herniou, E.A. (1999). Phylogeny of the Platyhelminthes and the evolution of parasitism. *Biological Journal of the Linnean Society* **68**, 257–287.
- Lockyer, A.E., Olson, P.D. and Littlewood, D.T.J. (2003). Utility of complete large and small subunit rRNA genes in resolving the phylogeny of the Neodermata (Platyhelminthes): implications and a review of the cercomer theory. *Biological Journal of the Linnean Society* **78**, 155–171.
- Maddison, W.P. and Maddison, D.R. (2000). *MacClade. Version 4*. Sunderland, Massachusetts: Sinauer Associates.
- Madhavi, R. (1978). Life history of *Genarchopsis goppo* Ozaki, 1925 (Trematoda: Hemiuridae) from the freshwater fish *Channa punctata*. *Journal of Helminthology* **52**, 251–259.
- Martin, W.E. (1956). The life cycle of *Catatropis johnstoni* n. sp. (Trematoda: Notocotylidae). *Transactions of the American Microscopical Society* **75**, 117–128.
- Martins, E.P., ed. (1996). *Phylogenies and the comparative method in animal behavior*. Oxford: Oxford University Press.
- Mas-Coma, S. and Montoliu, I. (1986). The life cycle of *Brachylaima ruminiae* n. sp. (Trematoda: Brachylaimidae), a parasite of rodents. *Zeitschrift für Parasitenkunde* **72**, 739–753.

- Matthews, B.F. (1980). *Cercaria vaullegeardi* Pelseneer, 1906 (Digenea: Hemiuridae): the daughter sporocyst and emergence of the cercaria. *Parasitology* **81**, 61–69.
- Matthews, R.A. (1974). The life-cycle of *Bucephaloides gracilescens* (Rudolphi, 1819) Hopkins, 1954 (Digenea: Gasterostomata). *Parasitology* **68**, 1–12.
- Murrills, R.J., Reader, T.A.J. and Southgate, V.R. (1985). Studies on the invasion of *Notocotylus attenuatus* (Notocotylidae: Digenea) into its snail host *Lymnaea peregra*: the contents of the fully embryonated egg. *Parasitology* **91**, 397–405.
- Niewiadomska, K. (2002). Superfamily Diplostomoidea Poirier, 1886. In: *Keys to the Trematoda* (D.I. Gibson, A. Jones and R.A. Bray, eds), Vol. 1, pp. 159–166. Wallingford and New York: CABI Publishing.
- O'Grady, R.T. (1985). Ontogenetic sequences and the phylogenetics of parasitic flatworm life cycles. *Cladistics* **1**, 159–170.
- Olson, P.D., Cribb, T.H., Tkach, V.V., Bray, R.A. and Littlewood, D.T.J. (2003). Phylogeny and classification of the Digenea (Platyhelminthes: Trematoda). *International Journal for Parasitology* **33**, 733–755.
- Palombi, A. (1942). Il ciclo biologico di *Ptychogonimus megastoma* (Rud.). Osservazioni sulla morfologia e fisiologia delle forme larvali e considerazioni filogenetiche. *Rivista di Parasitologia* **6**, 117–172.
- Pearson, J.C. (1956). Studies on the life cycles and morphology of the larval stages of *Alaria arisaemoides* Augustine and Uribe, 1927 and *Alaria canis* LaRue and Fallis, 1936 (Trematoda: Diplostomidae). *Canadian Journal of Zoology* **34**, 295–387.
- Pearson, J.C. (1961). Observations on the morphology and life cycle of *Neodiplostomum intermedium* (Trematoda: Diplostomatidae). *Parasitology* **51**, 133–172.
- Pearson, J.C. (1968). Observations on the morphology and life-cycle of *Paucivitellosus fragilis* Coil, Reid & Kuntz, 1965 (Trematoda: Bivesiculidae). *Parasitology* **58**, 769–788.
- Pearson, J.C. (1972). A phylogeny of life-cycle patterns of the Digenea. *Advances in Parasitology* **10**, 153–189.
- Pearson, J.C. (1992). On the position of the digenean family Heronimidae: an inquiry into a cladistic classification of the Digenea. *Systematic Parasitology* **21**, 81–166.
- Poulin, R. and Cribb, T.H. (2002). Trematode life cycles: short is sweet? *Trends in Parasitology* **18**, 176–183.
- Prévôt, G., Bartoli, P. and Deblock, S. (1976). Cycle biologique de *Maritrema misenensis* (A. Palombi, 1940), n. comb. (Trematoda: Microphallidae, Travassos, 1920) du midi de la France. *Annales de Parasitologie Humaine et Comparée* **51**, 433–446.
- Rohde, K. (1972). The Aspidogastrea, especially *Multicotyle purvisi* Dawes, 1941. *Advances in Parasitology* **10**, 78–151.
- Rohde, K. (1973). Structure and development of *Lobatostoma manteri* sp. nov. (Trematoda: Aspidogastrea) from the Great Barrier Reef, Australia. *Parasitology* **66**, 63–83.
- Rohde, K. (1975). Early development and pathogenesis of *Lobatostoma manteri* Rohde (Trematoda: Aspidogastrea). *International Journal for Parasitology* **5**, 597–607.
- Rohde, K. (2001). The Aspidogastrea: an archaic group of Platyhelminthes. In: *Interrelationships of the Platyhelminthes* (D.T.J. Littlewood and R.A. Bray, eds), pp. 159–167. London: Taylor & Francis.

- Rohde, K. and Sandland, R. (1973). Host-parasite relations in *Lobatostoma manteri* Rohde (Trematoda: Aspidogastrea). *Zeitschrift für Parasitenkunde* **42**, 115-136.
- Sewell, R.B.S. (1922). Cercariae indicae. *Indian Journal of Medical Research* **10** (Supplement), 1-370.
- Shameem, U. and Madhavi, R. (1991). Observations on the life-cycles of two haploporid trematodes, *Carassotrema bengalense* Rekharani & Madhavi, 1985 and *Saccocoelioides martini* Madhavi, 1979. *Systematic Parasitology* **20**, 97-107.
- Shoop, W.L. (1988). Trematode transmission patterns. *Journal of Parasitology* **74**, 46-59.
- Sillman, E.I. (1962). The life history of *Azygia longa* (Leidy, 1851) (Trematoda: Digenea), and notes on *A. acuminata* Goldberger, 1911. *Transactions of the American Microscopical Society* **81**, 43-65.
- Smith, J.W. (1997a). The blood flukes (Digenea: Sanguinicolidae and Spirorchidae) of cold-blooded vertebrates: Part 1. A review of the literature published since 1971, and bibliography. *Helminthological Abstracts* **66**, 255-294.
- Smith, J.W. (1997b). The blood flukes (Digenea: Sanguinicolidae and Spirorchidae) of cold-blooded vertebrates: Part 2. Appendix I: Comprehensive parasite-host list; Appendix II: Comprehensive host-parasite list. *Helminthological Abstracts* **66**, 329-344.
- Sprent, J.F.A. (1983). Observations on the systematics of ascaridoid nematodes. In: *Concepts in nematode systematics* (A.R. Stone, H.M. Platt and L.F. Khalil, eds), pp. 303-319. London: Academic Press.
- Stunkard, H.W. (1959). The morphology and life-history of the digenetic trematode, *Asymphylogora amnicolae* n. sp.; the possible significance of progenesis for the phylogeny of the Digenea. *Biological Bulletin* **117**, 562-581.
- Stunkard, H.W. (1964). The morphology, life history and systematics of the digenetic trematode, *Homalometron pallidum* Stafford, 1904. *Biological Bulletin* **126**, 163-173.
- Stunkard, H.W. (1968). The asexual generations, life-cycle, and systematic relations of *Microphallus limuli* Stunkard, 1951 (Trematoda: Digenea). *Biological Bulletin* **134**, 332-343.
- Thomas, J.D. (1958). Studies on the structure, life history and ecology of the trematode *Phyllostomum simile* Nybelin, 1926 (Gorgoderidae: Gorgoderinae) from the urinary bladder of brown trout, *Salmo trutta* L. *Proceedings of the Zoological Society of London, Series B* **130**, 397-435.
- Wall, L.D. (1951). The life history of *Vasotrema robustum* (Stunkard 1928), Trematoda: Spirorchidae. *Transactions of the American Microscopical Society* **70**, 173-184.
- Wardle, W.J. (1975). *Cercaria anadarae* sp. n. parasitizing a bivalve mollusc, *Anadara brasiliensis* (Lamarck), from the northwest Gulf of Mexico. *Journal of Parasitology* **61**, 1048-1049.
- Watson, R.A. (1984). The life cycle and morphology of *Tetracerasta blepta*, gen. et. sp. nov., and *Stegodexamene callista*, sp. nov. (Trematoda: Lepocreadiidae) from the long-finned eel, *Anguilla reinhardtii* Steindachner. *Australian Journal of Zoology* **32**, 177-204.
- Yamaguti, S. (1943). On the morphology of the larval forms of *Paragonimus westermanii* with special reference to their excretory system. *Japanese Journal of Zoology* **10**, 461-467.
- Zelmer, D.A. and Esch, G.W. (1998). Bridging the gap: the odonate naiad as a paratenic host for *Haliipegus occidialis* (Trematoda: Hemiuridae). *Journal of Parasitology* **84**, 94-96.