

CHANSON, H. (2000). "Introducing Originality and Innovation in Engineering Teaching: the Hydraulic Design of Culverts." *European Journal of Engineering Education*, Vol. 25, No. 4, pp. 377-391 (ISSN 0304-3797).

Introducing Originality and Innovation in Engineering Teaching:

the Hydraulic Design of Culverts

by

H. CHANSON

Senior Lecturer in Fluid mechanics, Hydraulics and Environmental Engineering

Department of Civil Engineering, The University of Queensland, Brisbane QLD 4072, Australia

E-mail : h.chanson@mailbox.uq.edu.au

CHANSON, H. (2000). "Introducing Originality and Innovation in Engineering Teaching: the Hydraulic Design of Culverts." *European Journal of Engineering Education*, Vol. 25, No. 4, pp. 377-391 (ISSN 0304-3797).

NOTE ON THE AUTHOR

Dr Hubert CHANSON received a degree of 'Ingénieur Hydraulicien' from the Ecole Nationale Supérieure d'Hydraulique et de Mécanique de Grenoble (France) in 1983 and a degree of 'Ingénieur Génie Atomique' from the 'Institut National des Sciences et Techniques Nucléaires' in 1984. He worked for the industry in France as a R&D engineer at the Atomic Energy Commission from 1984 to 1986, and as a computer professional in fluid mechanics for Thomson-CSF between 1989 and 1990. From 1986 to 1988, he studied at the University of Canterbury (New Zealand) as part of a Ph.D. project. In 1999, he was awarded a Doctor of Engineering (D.Eng.) at the University of Queensland.

Dr CHANSON is a senior lecturer in fluid mechanics, hydraulics and environmental engineering at the University of Queensland since 1990. His research interests include design of hydraulic and coastal structures, experimental investigations of two-phase flows, water quality modelling in coastal and hydraulic structures, environmental management and natural resources, and engineering heritage. He authored three books : "Hydraulic Design of Stepped Cascades, Channels, Weirs and Spillways" (*Pergamon*, 1995), "Air Bubble Entrainment in Free-Surface Turbulent Shear Flows" (*Academic Press*, 1997) and "The Hydraulics of Open Channel Flows : An Introduction" (*Edward Arnold*, 1999). His publication record includes over 160 international refereed papers. Dr CHANSON has been active also as consultant for both governmental agencies and private organisations.

He has been awarded four fellowships from the Australian Academy of Science. In 1995 he was a Visiting Associate Professor at National Cheng Kung University (Taiwan R.O.C.) and he was a Visiting Research Fellow at Toyohashi University of Technology (Japan) in 1999. Dr CHANSON was the keynote lecturer at the 1998 ASME Fluids Engineering Symposium on Flow Aeration and at the Workshop on Flow Characteristics around Hydraulic Structures (Nihon University, Japan 1998). He gave an invited lecture at the International Workshop on Hydraulics of Stepped Spillways (ETH-Zürich, 2000). He lectured several short courses in Australia and overseas (e.g. Japan, Taiwan).

CHANSON, H. (2000). "Introducing Originality and Innovation in Engineering Teaching: the Hydraulic Design of Culverts." *European Journal of Engineering Education*, Vol. 25, No. 4, pp. 377-391 (ISSN 0304-3797).

ABSTRACT

Recently the teaching of engineering design has become a presentation of standards and codes rather than the learning of sound design practices. Too many students request formulae and equations to solve a design exercise and they fail to develop any design originality. The present student attitude leads to young graduate engineers without critical ability and innovative flair. The writer has developed an innovative hydraulic design exercise based upon culvert design. Each design exercise could lead to more than one correct design per student in the class. Students have to learn basic design calculations based upon lecture material, notes, field visits and laboratory experiment. The practical component (laboratory, field visit) contributes significantly to their understanding of the complete system, including some basic safety and professional issues.

CHANSON, H. (2000). "Introducing Originality and Innovation in Engineering Teaching: the Hydraulic Design of Culverts." *European Journal of Engineering Education*, Vol. 25, No. 4, pp. 377-391 (ISSN 0304-3797).

EDUCATIONAL SUMMARY

1. The paper presents a new way to teach hydraulic design to civil and environmental engineering students in an undergraduate curriculum.
2. The hydraulic design of culvert is introduced as part of a complete design approach.
3. The paper describes engineering design techniques in which individual originality and innovation is required.
4. The analysis of the design procedures highlights the original input that each student must bring.
5. Case studies are used to support the undergraduate teaching of open channel hydraulics and design of hydraulic structures.
6. The standard text recommended in the course is "The hydraulics of open channel flow: an introduction" (CHANSON 1999).

1. INTRODUCTION

According to the dictionaries, an engineer is "a designer or builder, a person who carries through an enterprise by skilful or artful contrivance" (e.g. The Penguin English Dictionary 1985-86, Merriam-Webster's Collegiate Dictionary 1997). In recent times, the teaching of engineering design has become more the presentation of standards and codes, than the learning of design originality and safety. At undergraduate level and in postgraduate classes, too many students request formulae and equations to solve a design exercise. They fail often to read the specifications, to assess the problem and to analyse the tasks involved, and to develop an original design. The present student attitude leads to young graduate engineers without critical ability and innovative flair.

In practice, many engineers duplicate existing designs including their mistakes. A famous example in hydraulic design is the spillway structure of the New Victoria dam, Perth (1990, Australia). The design of the spillway was copied from the Upper Stillwater dam (1987, USA). The American design was to be a 4.6-m long broad-crest followed by a straight 59-degree stepped chute but the final design is a 9.1-m long broad-crest followed by a 72-degree chute and then a 59 degrees chute. The change in design was made to allow truck access. It had no hydrodynamic nor structural validity. In fact the final design has increased the risks of jet deflection and improper operation during overflows at the transition between the crest and the 72-degree chute. Nonetheless the Upper Stillwater crest design was duplicated for the New Victoria dam spillway without critical analysis (CHANSON 1997).

The writer has developed an innovative hydraulic design exercise which could lead to more than one correct design per student in the class. Students must develop their individual expertise in culvert design. They have to learn how to calculate an efficient design based upon lecture material, notes, field visit(s) and laboratory experiment. They are expected to provide detailed drawings and justifications of their calculations.

Culvert design

A culvert is a covered channel of relatively short length designed to pass water through an embankment (e.g. highway, railroad, dam). The design requires a hydrological study of the upstream catchment to estimate the maximum (design) discharge and the risks of exceptional (emergency) floods. The dimensions of the culvert are based on hydraulic, structural and geotechnical considerations. Indeed the culvert height and width affect the size and cost of the

CHANSON, H. (2000). "Introducing Originality and Innovation in Engineering Teaching: the Hydraulic Design of Culverts." *European Journal of Engineering Education*, Vol. 25, No. 4, pp. 377-391 (ISSN 0304-3797).

embankment. The culvert impact on the environment must also be taken into account : e.g., flooding of the upstream plain.

The design process is a system approach. The system must be identified as well as the design objectives and constraints. Its detailed analysis must be conducted and, the engineers should ask if their final design responds to the objectives.

HYDRAULIC DESIGN OF CULVERT

The hydraulic performances of a culvert are the design discharge Q_{des} , the upstream total head and the maximum (acceptable) head loss ΔH . Head losses must be minimised to reduce upstream backwater effects (i.e. upstream flooding). The primary design constraints are : [1] the cost must be (always) minimum, [2] the afflux¹ must be small and preferably minimum, [3] eventually the embankment height may be given or may be part of the design and [4] a scour protection may be considered, particularly if a hydraulic jump might take place near the culvert outlet. The hydraulic design is basically an optimum compromise between discharge capacity and head loss. In practice short culverts are designed for free-surface flow with critical flow conditions² in the throat. The final design may vary from a simple geometry (i.e. standard box culvert) to a hydraulically-smooth shape (i.e. MEL culvert³) (Fig. 1 and 2).

STANDARD CULVERTS

A standard culvert is designed to pass waters at a minimum cost. The culvert construction must be simple : e.g., circular pipes, precast concrete boxes. The culvert flow may exhibit various flow patterns : e.g., free-surface inlet flow conditions or submerged entrance, inlet control or outlet control (Fig. 1 and 3) (4).

The discharge capacity of the barrel is primarily related to the flow pattern. When free-surface flow takes place in the barrel, the discharge is fixed only by the entry conditions, and the discharge is typically estimated as :

$$\frac{Q}{B} = C_D * \frac{2}{3} * \sqrt{\frac{2}{3} * g * (H_1 - z_{inlet})}^{1.5} \quad \text{Free-surface inlet flow (1)}$$

$$\frac{Q}{B} = C * D * \sqrt{2 * g * (H_1 - z_{inlet} - C * D)}$$

Submerged entrance & free-surface barrel flow (1)

¹The afflux is the rise of water level above normal free-surface level upstream of the culvert. It is a measure of the upstream flooding caused by the culvert design.

²In open channel flows, the flow conditions such as the specific energy is minimum are called the critical flow conditions (e.g. HENDERSON 1966, CHANSON 1999).

³The design of a Minimum Energy Loss culvert is associated with the concept of constant total head. The inlet and outlet must be streamlined in such a way that significant form losses are avoided. For an introduction on Minimum Energy Loss culverts, see APELT (1994). For a complete review of M.E.L. waterways, see APELT (1983).

⁴Inlet control occurs when the flow is controlled by the upstream flow conditions and the flow rate is independent of the downstream water level.

CHANSON, H. (2000). "Introducing Originality and Innovation in Engineering Teaching: the Hydraulic Design of Culverts." *European Journal of Engineering Education*, Vol. 25, No. 4, pp. 377-391 (ISSN 0304-3797).

where B is the barrel width and D is the barrel height (Fig. 1) (HENDERSON 1966). C_D equals 1 for rounded vertical inlet edges and 0.9 for square-edged inlet. C equals 0.6 for square-edged soffit and 0.8 for rounded soffit.

For drowned culverts (i.e. outlet control), the discharge is determined by the culvert resistance (i.e. primary and secondary losses) (e.g. US Bureau of Reclamation 1987, Concrete Pipe Association of Australasia 1991).

Design procedure

For standard culverts the design process is divided into two parts (e.g. HERR and BOSSY 1965, HEC No. 5). First a system analysis must be carried out to determine the objectives of the culvert, the design data, the constraints including the design flow Q_{des} and the design upstream total head H_{des} .

In a second stage, the barrel size is selected by a test-and-trial procedure, in which both inlet-control and outlet-control calculations are performed. At the end, the *optimum size* is the smallest barrel size allowing for inlet control operation.

Calculations of the barrel size are iterative :

1. Choose the barrel dimensions.
2. Assume an inlet control. Calculate the upstream total head corresponding to the design discharge Q_{des} assuming inlet control for different barrel sizes until the upstream head $H_1^{(ic)}$ satisfies the design specifications (i.e. $H_1^{(ic)} = H_{des}$).
3. Assume an outlet control. Use design charts to calculate the head loss ΔH from inlet to outlet for the design discharge Q_{des} (e.g. US Bureau of Reclamation 1987). Calculate the upstream total head $H_1^{(oc)}$:

$$H_1^{(oc)} = H_{tw} + \Delta H$$
 where H_{tw} is the tailwater head at design flow.
4. Compare the inlet control and outlet control results : $H_{des} = H_1^{(ic)} \lesseqgtr H_1^{(oc)}$. The larger value controls.

When the inlet control design head H_{des} (used in step 2) is larger than $H_1^{(oc)}$, inlet control operation is confirmed and the barrel size is correct. If $H_1^{(oc)}$ is larger than H_{des} , outlet control takes place. Step 3 must be then repeated with an increased barrel size until $H_1^{(oc)}$ satisfies the design specification H_{des} .

MINIMUM ENERGY LOSS CULVERTS

A Minimum Energy Loss (MEL) culvert is a streamlined structure designed with the concept of minimum head loss (Fig. 2 and 4). APELT (1983) presented an authoritative review of the topic. The basic design concepts are streamlining and critical flow conditions throughout all the waterway (inlet, barrel, outlet) (Fig. 5). The intake is designed with a smooth contraction into the barrel while the outlet (or diffuser) is shaped as a smooth expansion back to the natural channel. In a satisfactory design, the flow streamlines follow very smooth curves and no separation is observed as for a Venturi-meter installed in a circular pipe. MEL structures are designed to achieve critical flow conditions in all the engineered water waterway because the maximum discharge per unit width for a given specific energy is achieved at critical flow conditions (e.g. HENDERSON 1966). At the throat the discharge per unit width may be increased by lowering the barrel invert below the natural ground level.

CHANSON, H. (2000). "Introducing Originality and Innovation in Engineering Teaching: the Hydraulic Design of Culverts." *European Journal of Engineering Education*, Vol. 25, No. 4, pp. 377-391 (ISSN 0304-3797).

A simple design method

Professor C.J. APELT (The University of Queensland) proposed a simple method to calculate the basic characteristics of a MEL culvert. This method gives a preliminary design ⁽⁵⁾. Full calculations using the backwater equations are required to predict accurately the free-surface profile.

1. Decide the design discharge Q_{des} and the associated total head line (T.H.L.) in the flood plain.

(A) Neglect energy losses

2.1 Calculate the waterway characteristics in the throat (i.e. barrel) for critical flow conditions.

2.2 Calculate the inlet lip width B_{max} assuming critical flow conditions and natural bed level (i.e. $\Delta z_0 = 0$).

3.1 Decide the shapes of the fans.

3.2 Calculate the geometry of the fans to satisfy critical flow conditions everywhere (e.g. Fig. 7).

In the above steps, either the barrel width B_{min} is selected and the barrel invert drop Δz_0 is calculated; or Δz_0 is chosen and the barrel width is calculated.

(B) Include the energy losses

4. Adjust the bed profile of the waterway to take into account the energy losses.

5. Check the 'off-design' performances : i.e., $Q > Q_{des}$ and $Q < Q_{des}$.

TEACHING CULVERT DESIGN

The author developed a pedagogic tool to introduce students to culvert design. It covers lecture material, home work associated with site visit(s) as well as a culvert laboratory study which includes an audiovisual presentation, physical models of culvert and numerical computations (using the program HydroCulv). The aim of the course is to introduce students to some original hydraulic design as well as to hydraulic computations of culvert using a commercial package. Following the lecture material, students are involved in a home work associated with site visit(s) (individually or in groups). For a particular case study, the students are asked either to design a standard box culvert for a specified flow rate or to calculate the design discharge capacity of an existing structure, and the associated upstream water levels. Then they are requested to design a MEL waterway to pass a specific flood (e.g. 1 in 50 years flood) and to compare their design with the corresponding standard box culvert. For each site, there is usually a single optimum standard culvert design and a multitude of correct MEL designs. The multiplicity of MEL culvert designs results from the wide range of inlet and outlet shapes : e.g., parabolic, elliptic or hyperbolic sidewall curves.

Considering a practical application, the culvert design parameters are : design discharge = $100 \text{ m}^3/\text{s}$, barrel width = 8 m, zero afflux ⁽⁶⁾. The students are asked to design a box culvert with zero afflux, a box culvert with a 8-m wide barrel and a MEL culvert with zero afflux and a 8-m wide throat. A standard box culvert with invert set at ground level would need to be 50-m wide to pass the flood without afflux while a 8-m wide box culvert would cause an upstream water level rise (afflux) of about 4.4-m (Fig. 6). The MEL culvert design would require a 2.6-m deep excavation of the barrel. Figures 7A and 7B shows proper inlet designs that would pass the design flow rate with zero afflux. Each figure shows

⁵The simple method is based on the assumption that the flow is critical from the inlet to outlet lips including in the barrel.

⁶Other design parameters are : normal depth in the flood plain = 1.2 m (in absence of culvert), bed slope = 0.005, culvert length = 24 m. Barrel height = 3 m.

CHANSON, H. (2000). "Introducing Originality and Innovation in Engineering Teaching: the Hydraulic Design of Culverts." *European Journal of Engineering Education*, Vol. 25, No. 4, pp. 377-391 (ISSN 0304-3797).

the sidewalls and centreline invert elevation only. Figure 7C presents an improper that would create some upstream flooding for flow rates larger than 60% of the design flow rate (⁷).

Note the significant differences between the standard and MEL culvert designs. The MEL waterway concept was developed by Professors G.R. McKAY and C.J. APELT for the coastal plains of Queensland (North-East of Australia). Torrential rains during the wet season, associated with very small natural plain flood slope ($S_0 \sim 0.001$) and little fall (or head loss), place a heavy demand on culverts.

During each case study, the students may choose a multitude of inlet shapes. A correct design must be streamlined with occurrence of critical flow conditions at any location between the inlet lip and barrel. The complete inlet design requires the drawings of the lines of constant invert elevation. These are equipotential lines and the complete inlet design is similar to a flow net analysis (e.g. VALLENTINE 1969).

LABORATORY WORK

Each student spends one afternoon in a hydraulic laboratory (see Appendix). The students are first introduced to culvert design (video-presentation APELT 1994) before performing measurements in a standard box culvert model (Fig. 3) and a downstream MEL culvert model (Fig. 4). The models discharge an identical flow rate. They are made of fibreglass and perspex, and the students can see the basic flow patterns in the channel, barrel, inlet and outlet for design and non-design flow conditions (⁸) (Fig. 3). Identical flow conditions are input in a commercial software for standard culvert (e.g. HydroCulv). Comparisons between the physical model and computer program results are conducted and discussed with the help of the physical model. The comparative performances of standard and MEL culverts are also discussed for design and non-design flow conditions. At the end of the afternoon, the students are challenged on the effect of a flood larger than the design flow. Their response is discussed in group before being tested in the physical models for $1.5 \cdot Q_{des}$.

DISCUSSION : A TEACHER'S OPINION

The writer has taught hydraulic design at undergraduate and postgraduate levels for more than 10 years. At undergraduate levels, he introduces the students to spillway and culvert design. It is the writer's opinion that the hydraulic design of culvert offers an unique opportunity. The design exercise is based upon very basic hydraulic material : i.e., the concept of specific energy, critical flow conditions, ideal-fluid flow. Each case study may be developed as a series of design exercises with increasing complexity. For example, starting with a standard culvert design and ending with a MEL culvert design. Further many case studies may be based upon prototype culverts. Standard culverts are very common and the students can inspect several sites. In Brisbane, there are further a number of MEL culverts that are easily accessible (e.g. Fig. 4).

The practical component of the teaching is very important : i.e., the field trip and laboratory experiment. The writer's experience suggests that students gain an optimum understanding when all teaching components are combined : i.e.,

⁷The extent of the upstream flooding could be determined with detailed backwater computations and physical modelling.

⁸The experiments are conducted with flow rates ranging from 0.05 to 1.5 times the design discharge.

CHANSON, H. (2000). "Introducing Originality and Innovation in Engineering Teaching: the Hydraulic Design of Culverts." *European Journal of Engineering Education*, Vol. 25, No. 4, pp. 377-391 (ISSN 0304-3797).

lecture material, field visit, design exercise and laboratory experiment. The laboratory experiment is most useful to conduct comparisons between standard and MEL culvert performances, and also comparisons between physical modelling and computations (⁹).

The field trip are often conducted with the lecturer and sometimes with professional engineers. The students learn of all the technical aspects of a culvert : road, embankment, boxes or pipes, drainage, ... They can further picture the effects of upstream flooding. In the case of MEL culvert, the students can appreciate the barrel and inlet design, the low-flow channel design. They are often surprised by the small excavation depth not often perceptible.

By the end of the course, most students realise their ability to undertake the critical analysis of a professional design. They further understand that there might be more than one solution, and that the optimum design might be selected for non-technical reasons : e.g., politics when the Lord Mayor leaves upstream of a new culvert !

CONCLUSION

The writer has developed an innovative hydraulic design exercise based upon culvert design. It aims to challenge the critical ability and innovative flair of the students, as indeed each design exercise may lead to more than one correct design per student in the class. Students have to learn basic design calculations based upon lecture material, notes, field visits and laboratory experiment. The practical component (laboratory, field visit) contributes significantly to their understanding of the complete system, including some basic safety and professional issues.

It is the writer's opinion that the described teaching method has been very successful in the context of Australian civil and environmental engineering students. He further believes that the field visit under the supervision of the lecturer and sometimes of professional engineers gives an added dimension to the hydraulic design teaching.

ACKNOWLEDGMENTS

The author thanks especially Professor Colin J. APELT, University of Queensland, for his help and assistance. The technical background of the paper derived from Professor APELT's personal lecture notes.

⁹Most professional softwares perform 1-D or 2-D calculations. They fail to address the three-dimensional nature of the flow that may be visualised in the physical model.

CHANSON, H. (2000). "Introducing Originality and Innovation in Engineering Teaching: the Hydraulic Design of Culverts." *European Journal of Engineering Education*, Vol. 25, No. 4, pp. 377-391 (ISSN 0304-3797).

REFERENCES

- APELT, C.J. (1983). "Hydraulics of Minimum Energy Culverts and Bridge Waterways." *Australian Civil Engrg Trans.*, I.E.Aust., Vol. CE25, No. 2, pp. 89-95 (ISSN 0819-0259).
- APELT, C.J. (1994). "The Minimum Energy Loss Culvert." Videocassette VHS colour, Dept. of Civil Eng., University of Queensland, Australia, 18 minutes.
- CHANSON, H. (1997). "A Short History of Stepped Cascades in Australia." *ANCOLD Bulletin*, No. 106, Aug., pp. 101-111.
- CHANSON, H. (1999). "The Hydraulics of Open Channel Flows : An Introduction." *Edward Arnold*, London, UK, 512 pages.
- HENDERSON, F.M. (1966). "Open Channel Flow." *MacMillan Company*, New York, USA.
- VALLENTINE, H.R. (1969). "Applied Hydrodynamics." *Butterworths*, London, UK, SI edition.

APPENDIX - LABORATORY COMPONENTS

Audio-visual material :

APELT, C.J. (1994). "The Minimum Energy Loss Culvert." Videocassette VHS colour, Dept. of Civil Engineering, University of Queensland, Australia, 18 Minutes.

Physical model (standard culvert) :

The physical model characteristics are : $Q_{des} = 10$ L/s, $B_{max} = 1$ m, $B_{min} = 0.15$ m, $D = 0.11$ m, $L_{culv} = 0.5$ m, $d_{tw} = 0.038$ m, intake and outlet : 45-degree diffuser, $S_o = 0.0035$.

Physical model (MEL culvert) :

The physical model characteristics are : $Q_{des} = 10$ L/s, $B_{max} = 1$ m, $B_{min} = 0.10$ m, $D = 0.17$ m, barrel length : 0.6 m, $d_{tw} = 0.038$ m, barrel elevation 0.124 m lower than river bed.

Computer program :

HydroCulv Version 1.1 (HydroTools Software : dwilliams@compusmart.ab.ca).

Fig. 1 - Sketch of a standard culvert operation : inlet control and outlet control

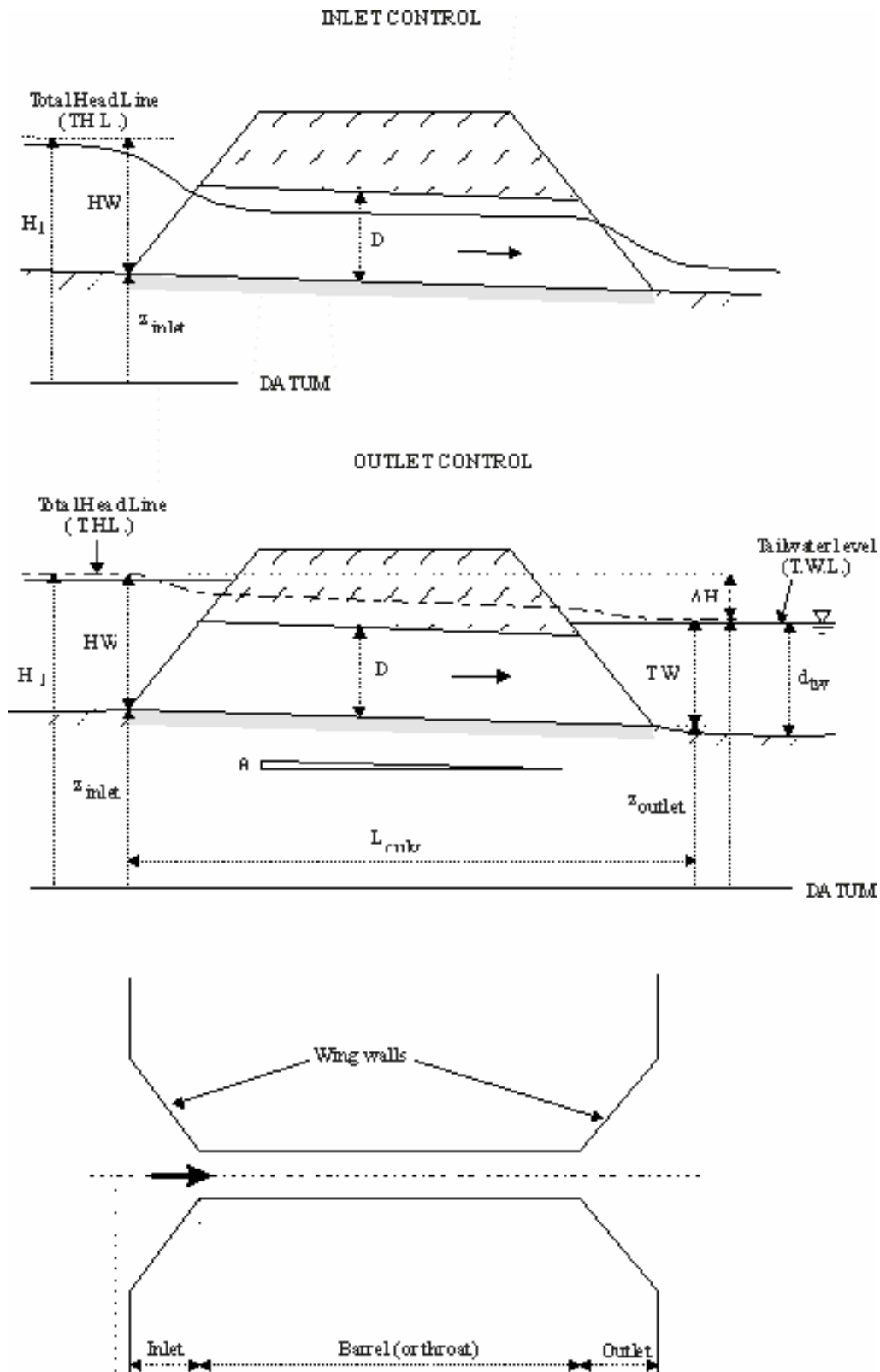

CHANSON, H. (2000). "Introducing Originality and Innovation in Engineering Teaching: the Hydraulic Design of Culverts." *European Journal of Engineering Education*, Vol. 25, No. 4, pp. 377-391 (ISSN 0304-3797).

Fig. 2 -- Sketch of a Minimum Energy Loss culvert

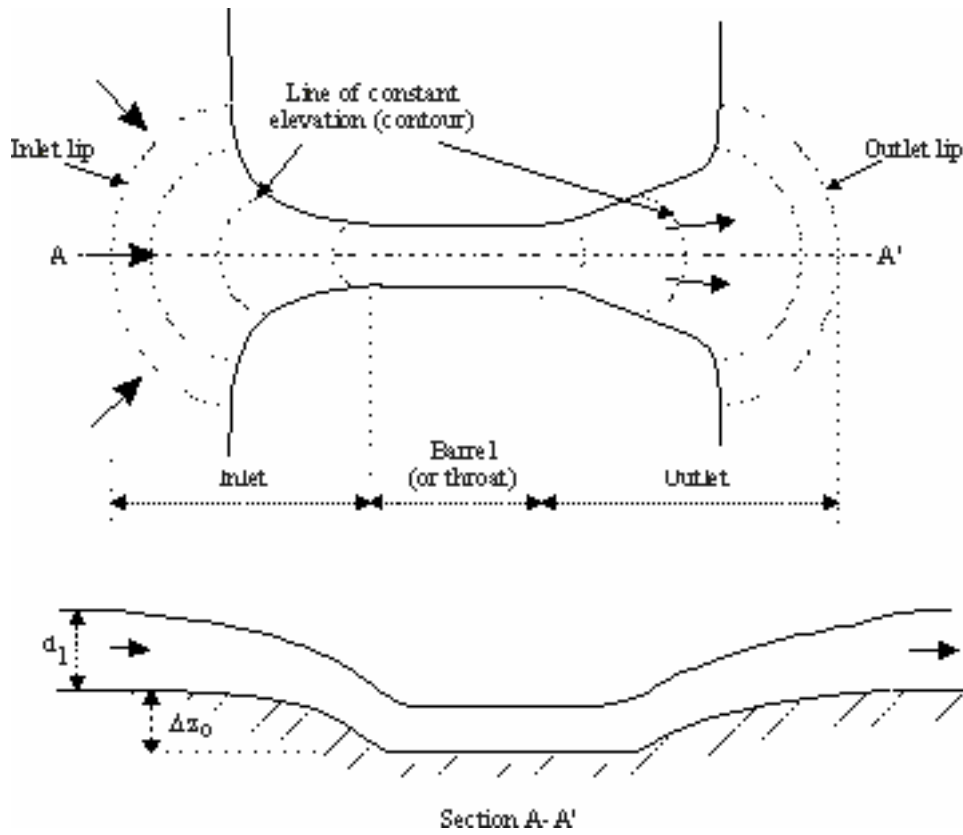

CHANSON, H. (2000). "Introducing Originality and Innovation in Engineering Teaching: the Hydraulic Design of Culverts." *European Journal of Engineering Education*, Vol. 25, No. 4, pp. 377-391 (ISSN 0304-3797).

Fig. 3 - Examples of model box culvert operation - Design flow conditions : $Q_{des} = 10 \text{ L/s}$, $d_{tw} = 0.038 \text{ m}$, $S_o = 0.0035$, $B_{min} = 0.15 \text{ m}$, $D = 0.107 \text{ m}$, $L_{culv} = 0.5 \text{ m}$

(A) Design flow conditions : view from upstream (flow from bottom right to top left) - $Q = 10 \text{ L/s}$, $d_{tw} = 0.038 \text{ m}$, $d_1 = 0.122 \text{ m}$ - Note the hydraulic jump downstream of the culvert

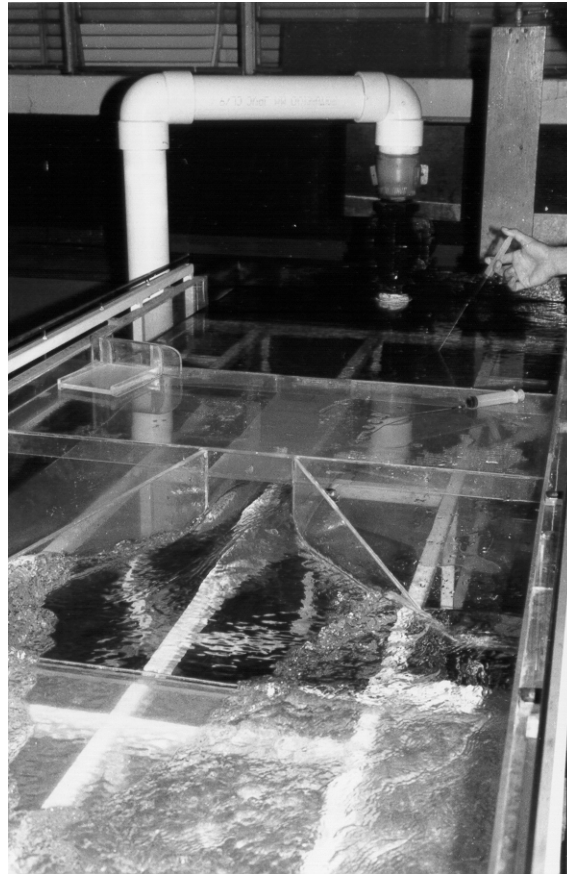

(B) Non-design flow conditions : view from upstream of the drowned barrel (flow from bottom right to top left) - $Q = 10 \text{ L/s}$, $d_{tw} = 0.109 \text{ m}$, $d_1 = 0.133 \text{ m}$, outlet control



CHANSON, H. (2000). "Introducing Originality and Innovation in Engineering Teaching: the Hydraulic Design of Culverts." *European Journal of Engineering Education*, Vol. 25, No. 4, pp. 377-391 (ISSN 0304-3797).

Fig. 4 - Photographs of a prototype MEL culvert below Ridge Street, Brisbane QLD, Australia - Design discharge : 220 m³/s; Barrel : 7 cells (2-m wide each)

(A) View of the inlet : a bicycle path passes in one of the barrel cell



CHANSON, H. (2000). "Introducing Originality and Innovation in Engineering Teaching: the Hydraulic Design of Culverts." *European Journal of Engineering Education*, Vol. 25, No. 4, pp. 377-391 (ISSN 0304-3797).

(B) View of the outlet - Note the low-flow channel in the foreground (left) and the bicycle path behind



Fig. 5 - Free-surface profile assumed in the 'simple design method'

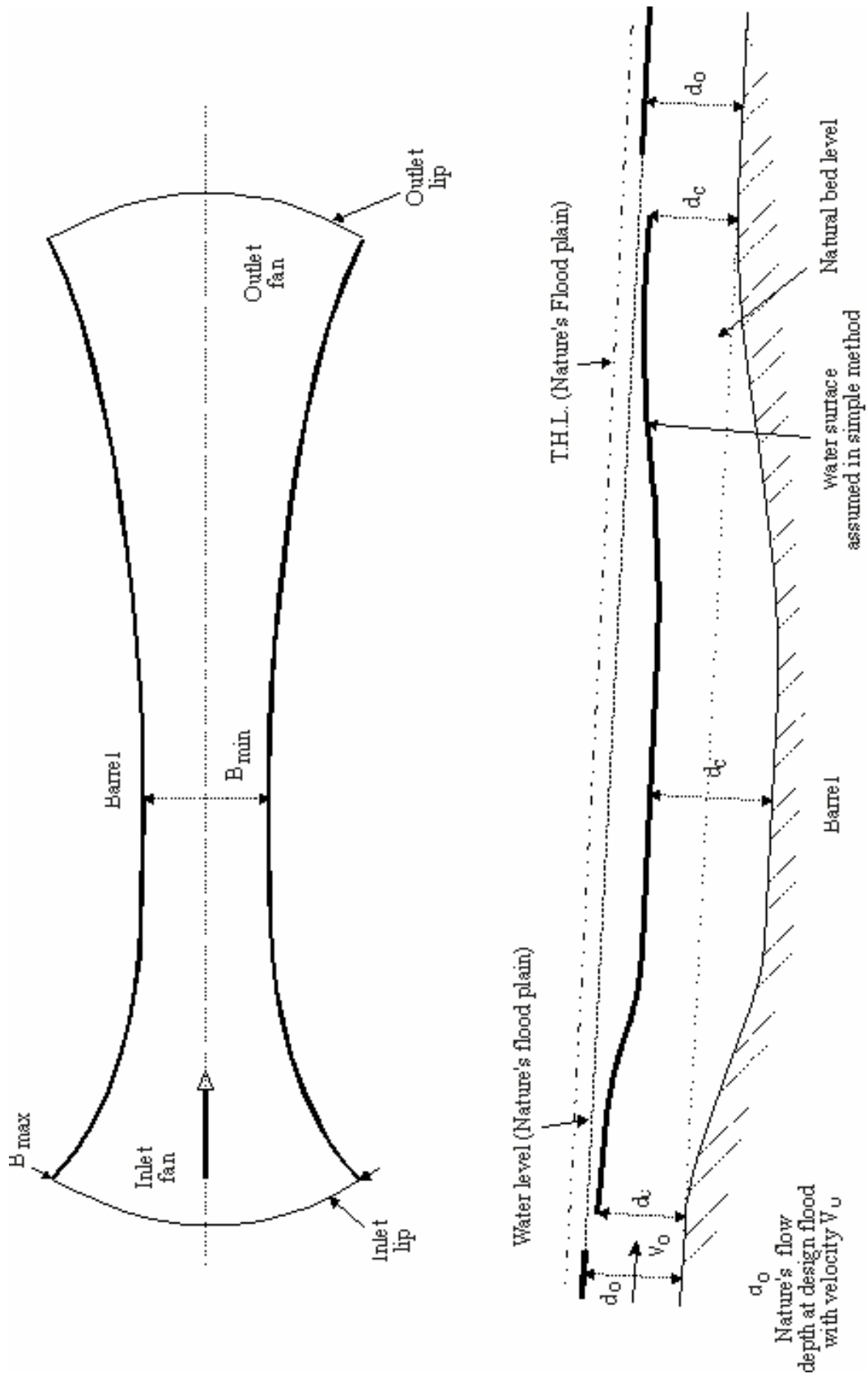

CHANSON, H. (2000). "Introducing Originality and Innovation in Engineering Teaching: the Hydraulic Design of Culverts." *European Journal of Engineering Education*, Vol. 25, No. 4, pp. 377-391 (ISSN 0304-3797).

Fig. 6 - Free-surface computations for a standard box culvert (program Hydroculv)

Design parameters : Design flow rate = $100 \text{ m}^3/\text{s}$ - Barrel width : 8 m - Normal depth in the flood plain (in absence of culvert) : 1.2 m

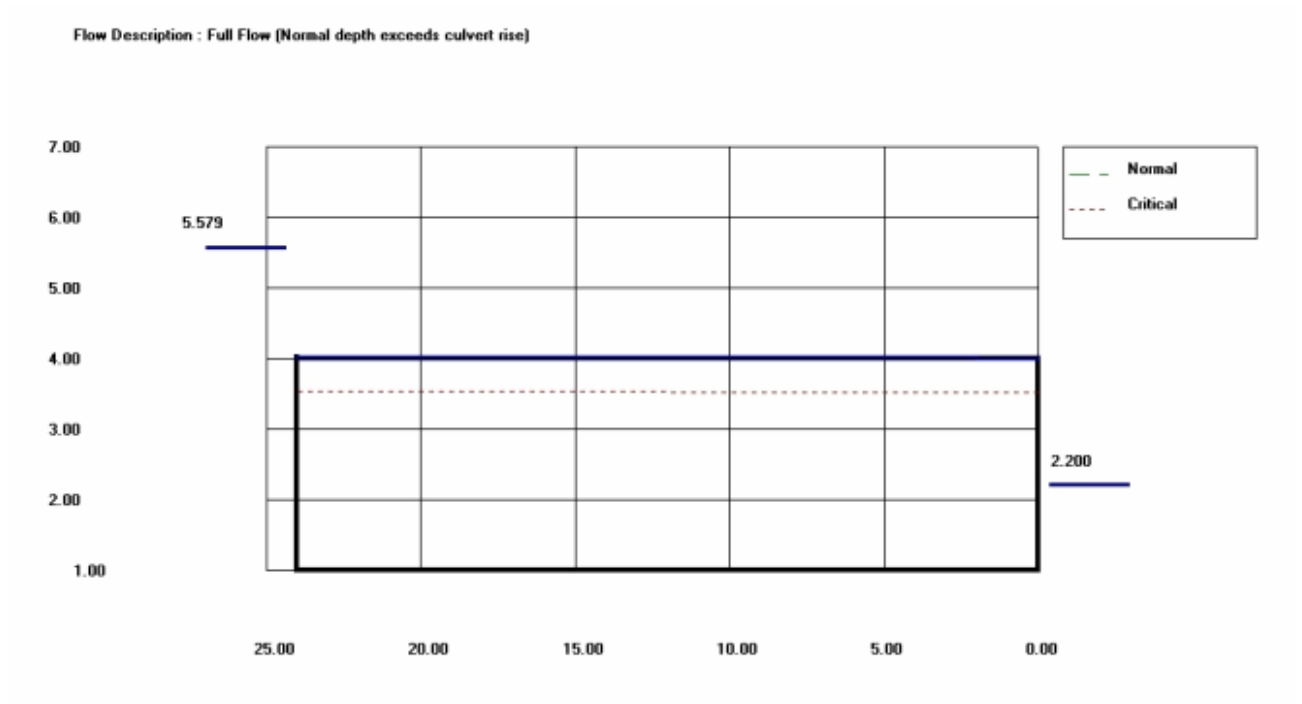
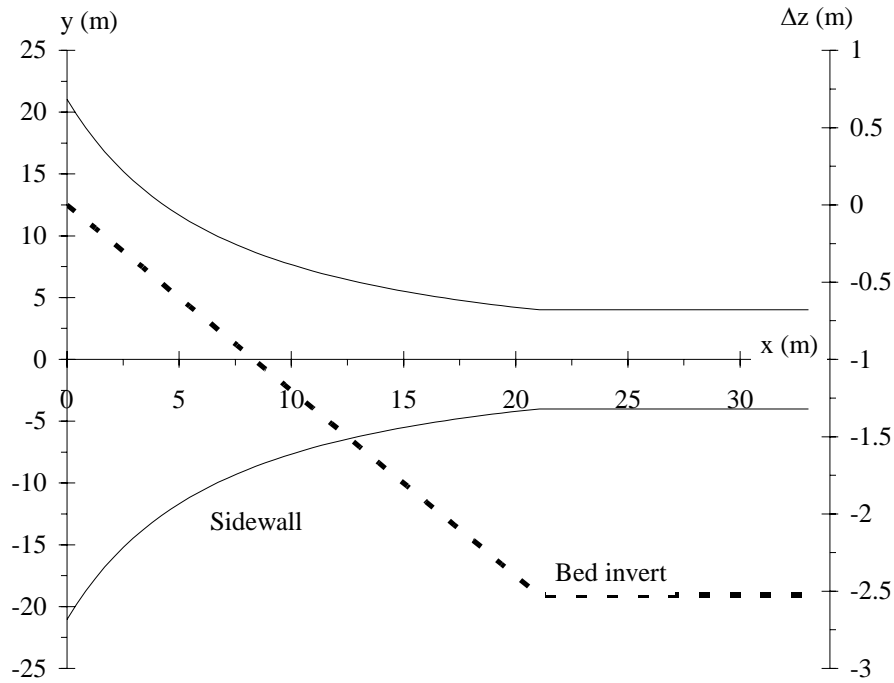
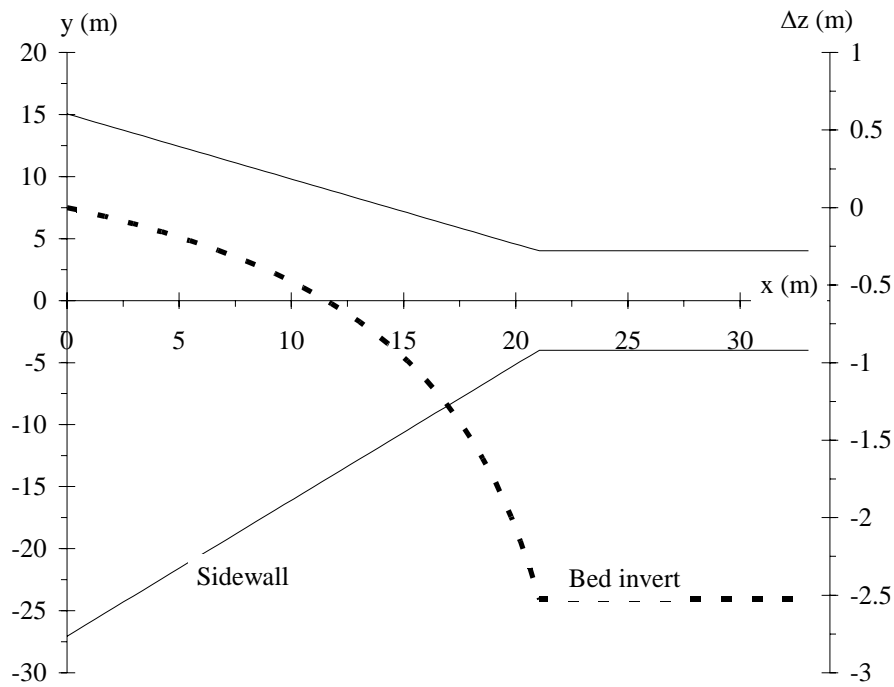

Figure 7 - MEL culvert design - Design parameters : Design flow rate = $100 \text{ m}^3/\text{s}$ - Barrel width : 8 m - Zero afflux - Normal depth in the flood plain (in absence of culvert) : $d_0 = 1.2 \text{ m}$

(A) Correct design



(B) Correct design



(C) Improper design : upstream flooding will occur for $Q > 58 \text{ m}^3/\text{s}$

