

An Investigation of Power Quality Problems in a Remote Mine Site in Papua New Guinea

Franz Alois Hemetsberger*

Placer (Granny Smith) Pty. Limited
P O Box 33, Laverton WA 6440
Franz_Hemetsberger@placerdome.com

Tapan Kumar Saha

School of Information Tech. & Electrical Engineering
University of Queensland, Qld-4072, Australia
saha@itee.uq.edu.au

Abstract:

Investigation and monitoring of power quality is necessary to maintain accurate operation of sensitive equipment. Electrical power systems of mines with their sophisticated technology will always have a need for monitoring power quality to ensure that critical processes are operating efficiently. Two of the most common power quality problems, Voltage Sag and Harmonics are investigated for a Remote Gold Mine in Papua New Guinea. Field power quality data is collected by PQNode[®] and then simulated using the PSCAD[®]/EMTDC[™] software. Results are then compared with appropriate standards and subsequently correct mitigation techniques are investigated.

Key Words: Power Quality, Voltage Sag, Harmonics, Motor Starting, Single line to ground fault

1. Introduction

The concern for the quality of electric power is increasing very rapidly due to change in load in power systems. The last decade has seen a significant change in components of power systems from being largely linear to partially nonlinear. The Electric Power Research Institute (EPRI) gave a rough estimation that in 1992, between 15 and 20 percent of the total load on a utility system would be nonlinear and it was expected that between 50 to 70 percent of all loads would be nonlinear by the year 2000 [1].

Investigation and monitoring of power quality is necessary to maintain accurate operation of sensitive equipment. Electrical power systems of mines with their sophisticated technology will always have a need for monitoring power quality to ensure that critical processes run efficiently. The most common power quality problems prevalent in the mining system are Voltage Sag and Harmonics and have been investigated in detail in this paper.

The Gold Mine in the Highlands of Papua New Guinea is

an isolated electrical power system. Experimental data was collected using the PQNode[®] 8010 [2] power quality measuring instrument and then PQ analysis is performed with the PSCAD[®]/EMTDC[™] software [3]. The power quality phenomena measured was simulated by PSCAD to see propagation through the system and was used to determine the necessary mitigation techniques.

2. Power System of the Remote Mine

The Mine Power System is a very typical radial system. Much of its loads are fixed which have been lumped together to simplify the system. The supply voltage is assumed to be fixed and transformers were lumped together and calculated on a common base. Load ratings used for the simulation are taken from data collected during July at the mine. The simplified single line diagram is shown in Figure 1.

Table 1: Transformer rated data

Location	Transformer Data		
	Rating (MW)	Impedance (%)	Winding Voltages
Waile Creek	6.25	9.42	132 / 11
Lime Plant	8.33	9.42	132 / 6.6
Anawe Substation	30	6.7	132 / 6.6
Anawe Substation Services	4	2.42	132 / .415
Village and Services	2.5	5.48	6.6 / 11
Porgera Town & Services	4.5	3.64	6.6 / .415
Refinery	2	1.5	6.6 / .415
Underground	1.5	5.23	6.6 / 11
Tawisakali Substation	30	6.7	132 / 6.6
Pit Service/Primary Crusher	1.5	3.16	6.6 / .415

Table 2: Motors Connected to the Sag Mill Bus

Motor	Rating (kW)	Drive
Sag Mill # 1	4070	Variable
Sag Mill # 2	4070	Variable
Ball Mill # 1	2240	Fixed
Ball Mill # 2	2240	Fixed
Ball Mill # 3	5565	Fixed
SABC Crusher # 1	300	Fixed
SABC Crusher # 2	300	Fixed

Transformer data is shown in Table 1. In the simulation the loads are assumed to have a power factor of 0.85 – 0.9 lagging. The two Sag Mills in the Mine system are

* This work was done during thesis work at the University of Queensland.

LEGEND

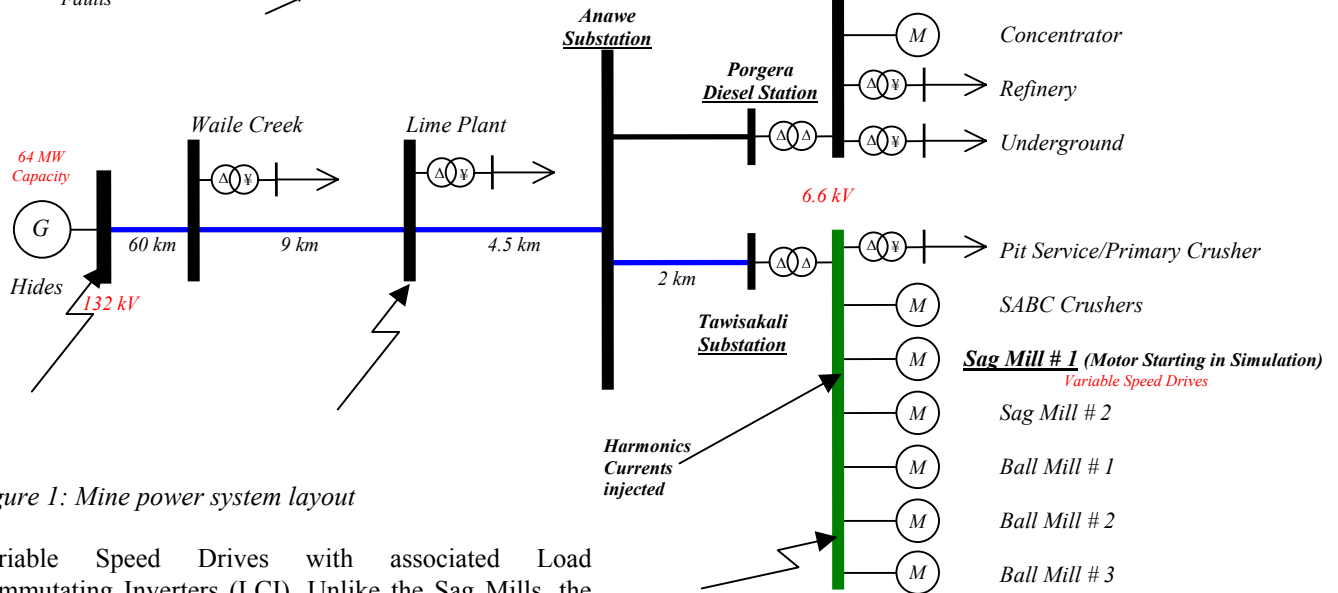
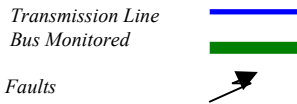

Figure 1: Mine power system layout

Variable Speed Drives with associated Load Commutating Inverters (LCI). Unlike the Sag Mills, the Ball Mills (1, 2 & 3) are fixed speed motors that need to be jogged before starting and cause significant voltage sag. Due to the availability of only one PQNode®, measurements were done only on one bus, the Sag Mill Bus, and a simulation of this phenomenon gave the extent of it throughout the system.

Three phase and single-line-to-ground Faults (SLGF) were simulated at the Power Station, the Lime Plant (after the 75 km of transmission line) and at the sag mill bus.

The main sources of harmonics in the Mine System are the Variable Speed Drives for the two Sag Mill Motors. Therefore, in the simulated system, harmonic currents are injected at the Sag Mill bus. The Mine has three passive harmonic filters tuned to 5.45×50 Hz, 12.2×50 Hz and 19×50 Hz. Harmonic currents at frequencies for the 5th, 13th and 19th harmonic are injected into the simulated system to see the propagation throughout the system. Magnitudes used are 0.1 and 0.01 percent of the fundamental respectively.

3. Measurement Results

The experimental data was measured from the third to the 24th of July 2003 with the PQNode® at the Sag Mill Bus. There were complications with the current waveforms due to complications in acquiring a measuring CT for the PQNode.

The voltage waveforms were recorded and a sample waveform is given below. Also shown below is the Total Harmonic Voltage Distortion (THVD) trend displayed by associated software PASS®.

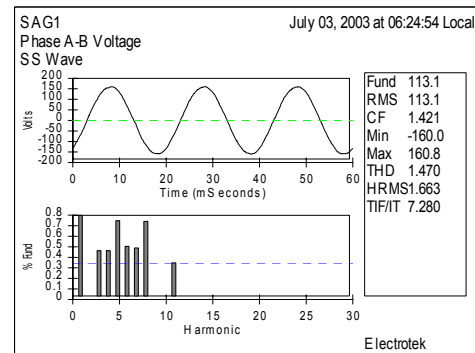

Figure 2: Sample recording showing Voltage waveform

Note the significant harmonic voltages are the 5th, 8th and the 11th. A number of waveform faults (61) were recorded during this time. The most distorted waveform is given in Figure 3.

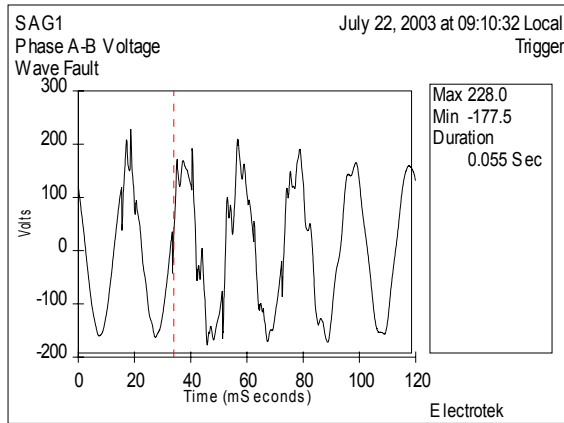

Figure 3: Sample waveform faults

The following is a summary of the voltage sag recorded.

Table 3

SAG1 - S ag S um m ar y Table July 05, 2003 at 00:06:36 Local
 Maxim um Num ber of E vents 24/07/03 21:28:58 Local

Depth ()	Duration (sec)					
	0.001 To	0.100 To	0.500 To	1.000 To	3.000 To	20.00 To
10 <= Depth < 30	3	11	4	20	0	0
30 <= Depth < 60	0	0	0	0	0	0
60 <= Depth < 99	0	0	0	0	0	0
99 <= Depth < 100	0	0	0	0	0	0

Maximum number of events at a single site = 38

Electrotek

The RMS voltage trend of one phase from PASS® is given in Figure 4 for the entire duration of the measurement.

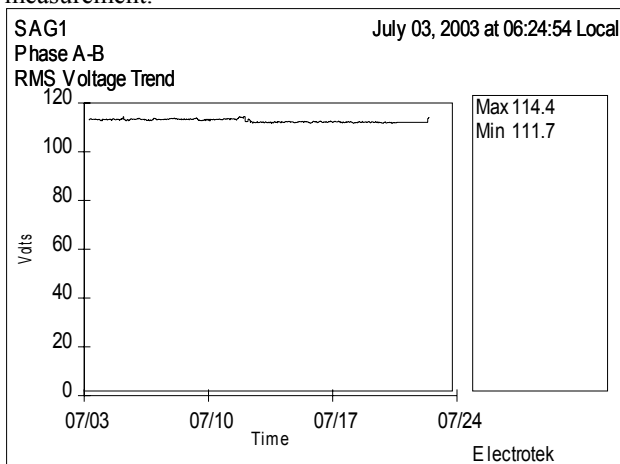

Figure 4: RMS Voltage trend of the Sag Mill Bus

The following are some of the more severe sags recorded due to the SAG Mill 1 and ball mill # 1 starting with associated jogs for the ball mill.

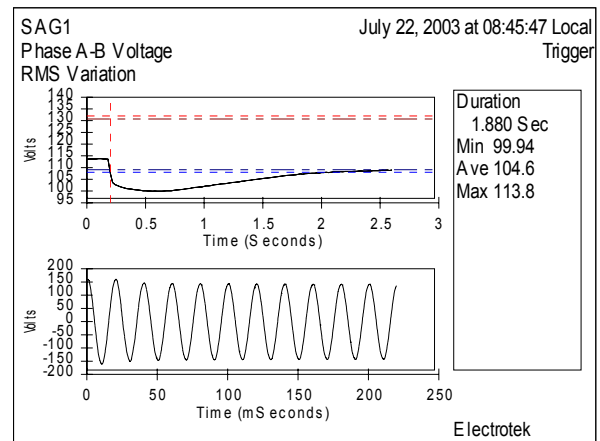

Figure 5: Sag Mill #1 Starting

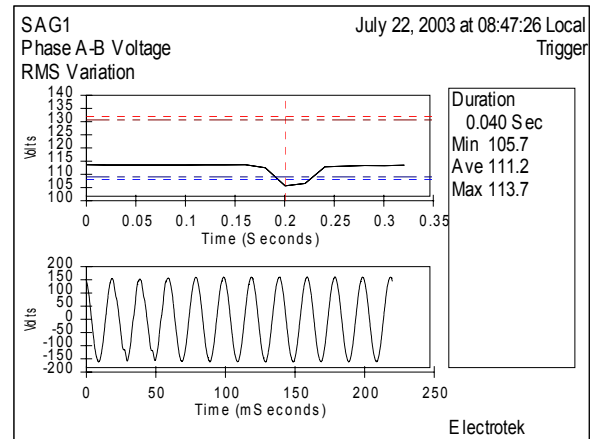

Figure 6: First Jogging of Ball Mill #1

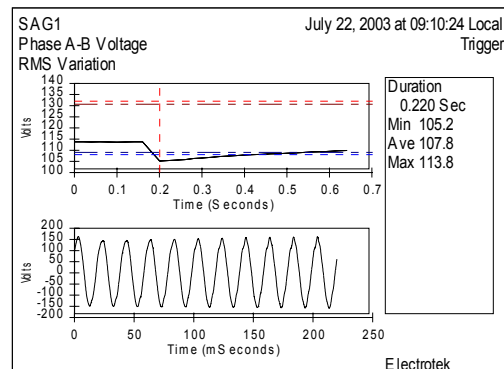

Figure 7 Second Jogging of Ball Mill #1.

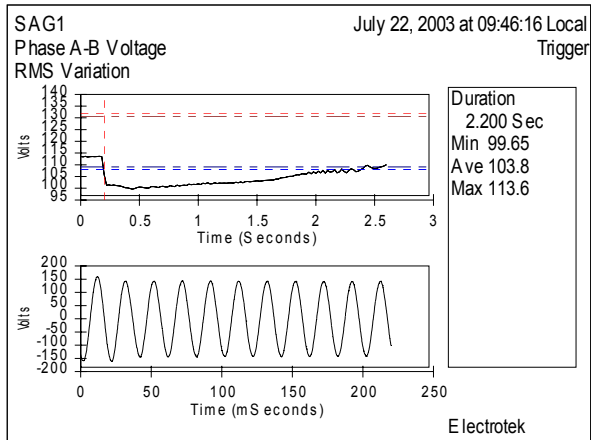

Figure 8: Ball Mill # 1 Starting

4. Simulation Results

The fifth, 9th and 11th Harmonic currents were injected into the sag mill bus to simulate and analyse the propagation of harmonic currents throughout the system. Most sensitive loads are at the refinery and concentrator of the Mine System. The voltage at the sag mill is shown in Figure 9.

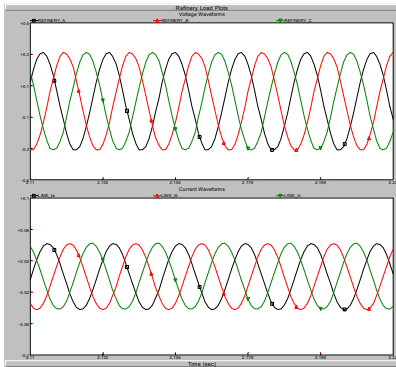

Figure 9: Voltage and Current waveforms at Refinery

Three phase faults were simulated with an impedance of 0.01Ω. These results are shown in Figures 10-12.

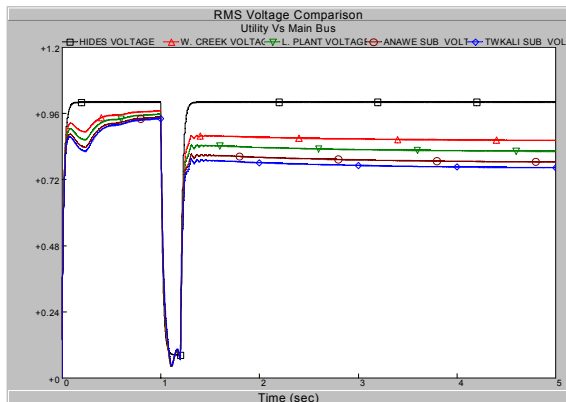

Figure 10 RMS voltages showing Three Phase Fault at Hides

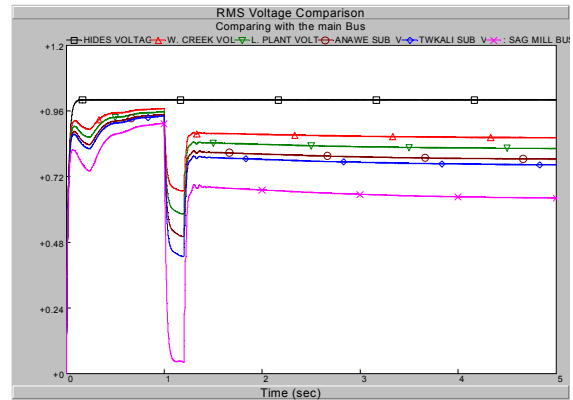

Figure 11 RMS voltages showing Three Phase Fault at the Sag Mill

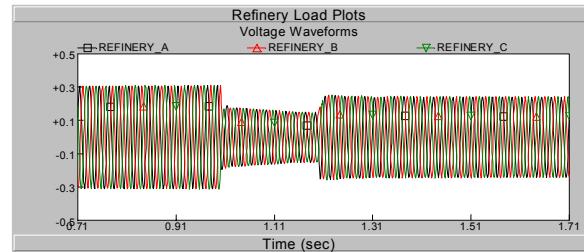

Figure 12 Voltages Waveforms at Refinery during the Three Phase Fault at the Sag Mill

Single-line-to-ground faults were also simulated with an impedance of 0.01Ω and results are shown in Figure 13.

5. Discussion

Much of the monitoring work done for the Mine power system is to investigate if there are any power quality problems to the system. The extent to which those problems affect costs is of more concern due to the need to reduce costs.

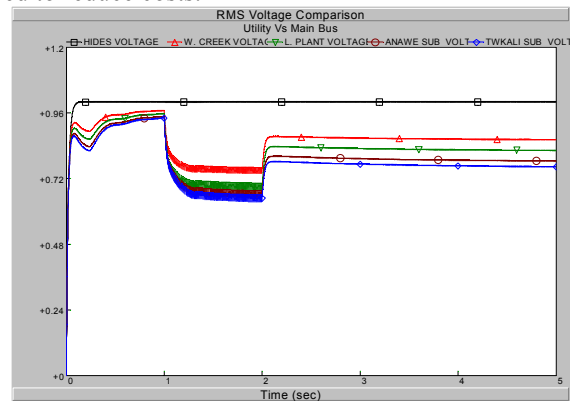

Figure 13 RMS Voltages during SLGF at the Lime Plant

Simulations of the starting of the sag mill motors are shown in Figures 14-15 at two locations.

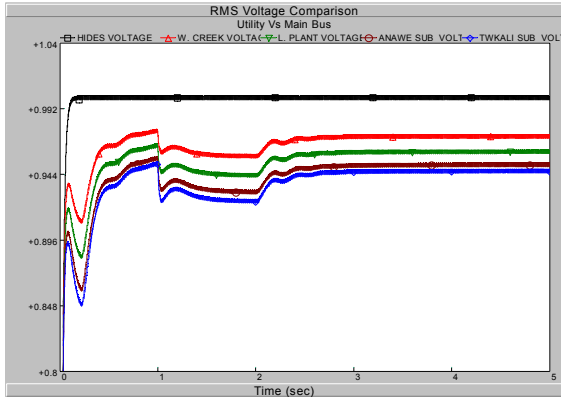

Figure 14 Propagation of Sag due to Sag Mill # 1 motor starting

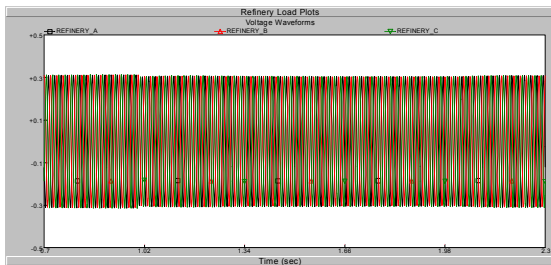

Figure 15: Voltage at the Refinery during Sag Mill # 1 motor starting

Therefore, many problems are mitigated rather than completely removed from a system. These problems are mitigated to within standards, which the margins in which frequency and voltage are allowed to vary [4-6].

A number of assumptions were made when transferring the real system into the simulated system. The loads of the system were simulated according to energy usage for a given month. This could have been improved if actual motor parameters were known and the load data was specified to give an accurate simulation. However, a simulation analysis of this extent would require a lot of collaboration with the mine and could be time consuming. The limitation of the student version of PSCAD® also meant that loads had to be lumped. Upon comparison, the simulated system does perform a reasonable simulation of the actual system and it is adequate to determine the extent of the voltage sag caused by the large motors.

It is seen that the maximum Total Harmonic Voltage Distortion (THVD) is 3.1% of the fundamental. Total Harmonic Distortion acceptable level is set by IEEE 519 standard and is 5%. The measured and simulation data both have a THVD within this level.

A previous voltage study of the mine system looking into the prevention of under excitation of any of the generators at Hides gave cases where the voltage sag depth depended on the loading at the time. The most severe sag recorded during the July 2003 was sag of 0.88 p.u. (as shown in Figure 16) and occurred on the 11th of July when the system was loaded.

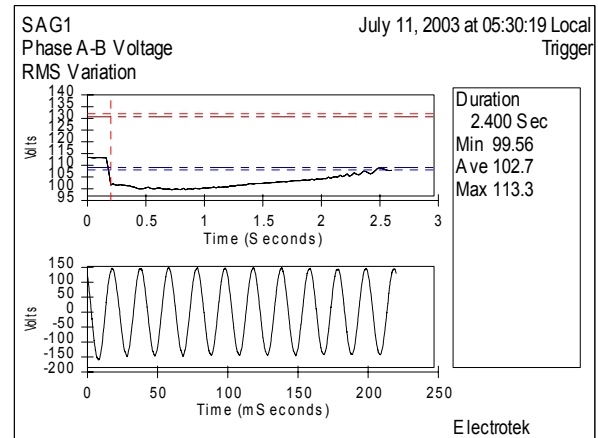

Figure 16: Most severe sag recorded

The Sag Mill is also a dynamic load with its large motors and associated smaller motors for pumps. The severe sag due to the loading is a phenomenon studied and even predicted to be caused by the motors themselves contributing to the sag [7-8]. This is very evident and shown in the simulation where the voltage does not recover because of the high current the induction motors draw at starting.

The voltage sag at the refinery is not as severe and this is due to its dedicated transformers. Since many of the transformers were removed from the simulation and seeing the sag at the refinery, it is safe to assume that the sag due to motor starting is within tolerance limits of most equipment. That is, line-conditioning practices in place are adequate, especially at the refinery where most process equipment are connected. All PLC's at the mine have a dedicated 110V transformer and their own UPSs to ensure that Sags are mitigated.

The most commonly used characterisation of voltage sag is its magnitude and duration [9]. The voltage sags, which were measured at the mine were characterised using the CBEMA curve and most of the sags are well within tolerance as is shown in Figure 17.

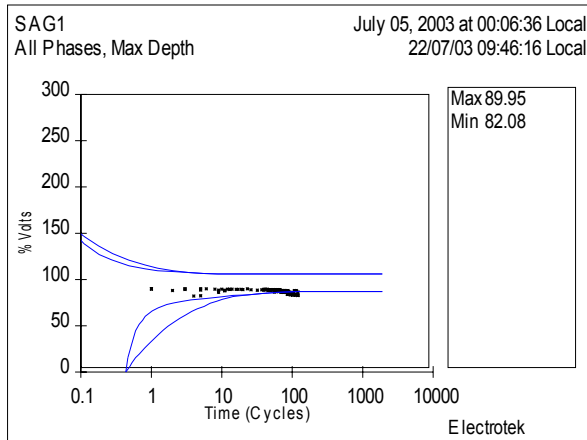

Figure 17: Characterising recorded sags with the CBEMA curve

As no contacts were tripped during start up of any motors the line conditionings practices are adequate, however for further expansion of the system, a voltage stability study will need to be carried out to see that the system capacity is not pressed.

6. Mitigation Application

Voltage sag mitigation can be done through changes in power system configuration, increasing equipment immunity or the use of mitigation devices. It is well known that the delta connection of transformers prevents the flow of triplen harmonics. Other changes in system configuration that play a role in mitigation of power quality problems, especially voltage sags is in the reduction of the number of faults, reducing fault-clearing time or designing parallel feeders.

Faults can be reduced with the use of lightning arresters or using underground cables. Implementing an underground cable between Hides and Mine Operations can be an economically viable option for the Mine System since it spends a large amount of money in repairing its overhead transmission line after sabotages or compensation in using the land and its deprivation of the land resources such as trees.

Protective devices such as breakers and current-limiting fuse can be used to protect equipment from severe sags. Modern breakers have fast clearing times and can be an option that can also be looked at for increasing system reliability. As mentioned earlier, uninterruptible power supplies (UPS) are prevalent in the Mine System, especially in their use with Programmable Logic Controllers (PLCs). Because of its low cost and simple operation UPSs are almost a standard solution to voltage sag for lower voltages. During a voltage sag, the energy released from the battery block of the UPS maintains the

voltage at the dc bus. Since the measurements were done on a voltage transformer similar to that used for PLCs, it can be seen that the voltage sags are seen at its severity at the PLC terminals and it can be concluded that mitigation techniques should be implemented, especially at the Sag Mill.

A mitigation method for improving voltage sag is the use of a Dynamic Voltage Restorer. It is designed to protect voltage sags on lines feeding sensitive or critical equipment. It is similar in operation to Uninterruptible Power Supplies (UPS) but unlike UPS, the DVR is specifically designed for large loads ranging from 2MVA to 10MVA served at distribution voltage. The basic idea of the DVR is to inject the missing voltage into the system through a series injection transformer when it is subjected to voltage sags [10]. An important aspect of implementing the DVR is its implementation location. It should be connected to the system where there are sensitive loads. The Sag Mill Motors are ASDs and phase shifts caused by faults can cause the ASDs to malfunction. The DVR could be implemented with each of them it seems viable. The DVR can also be implemented in series with any sensitive refinery machinery also since most critical loads are located here. Many of these techniques are already implemented at the Mine system. Of course feasibility studies should be carried out to see if the power quality problem warrants a particular mitigation technique and if the payback time is reasonable and within the lifetime of the mining operation.

7. Conclusion and Recommendations

Common voltage sag phenomena are observed in the simulation. Sag magnitudes are less severe when the distance from the source of the voltage sag is larger. Voltage sag in this mine due to motor starting is concluded to be insignificant related to power quality concerns. Line conditioning techniques in the mine power system are adequate in sustaining operation of its sensitive equipment during its motor starting. Most recorded sags were within tolerance curves as described with the CBEMA tolerance curves. The more severe ones occurred during significant loading of the system and are due to induction motor starting. Available techniques are recommended if these sags become a problem in the future. Since the more severe sags occurred during a fully loaded system, it is advised that a voltage stability study be carried out to see the effects of the extra loading, if expansions are considered.

The voltage sag seen at the Refinery bus due to the starting of large motors at the Sag Mill shows that the sag is not that severe and is only 0.98 p. u. Extrapolation of

severe sag at the Sag mill of 0.88 p. u. will only be sag of 0.92 at the refinery, which is within tolerance capability of most equipment. Furthermore, since PLCs have dedicated transformers and UPSs, this sag is further mitigated and is insignificant relating to power quality concerns.

THVD are seen to be within IEEE 519-1995 standards but no identification of the THCD was carried out due to noted complications. Hence, it is recommended that a full harmonics study be carried out to complete this project. The Dynamic voltage restorer is a solution that could be looked at for the large motors and a feasibility study can be carried out if the voltage sag becomes an issue. At this stage, the sporadic nature of sags due to motor starting does not warrant such a cost.

8. References

1. Mike Holt, National Electrical Code Internet Connection, "Case studies", <<http://www.mikeholt.com/technical.php?id=powerquality/technicalpowerqualityharmonics>>
2. 8010 PQNode / PASS User's Guide, BMI, 1993.
3. "PSCAD/EMTDC Version 3.0" Website, 2003 http://www.pscad.com/main/pscadc/pscadc_v3/index.html
4. IEEE Standards Board, "IEEE Std 1159-1995, IEEE Recommended Practice for Monitoring Electric Power Quality", IEEE, Inc., New York June 14 1995.
5. IEEE-SA Standards Board, "IEEE Recommended Practices for Evaluating Electric Power System Compatibility with Electronic Process Equipment", IEEE, Inc., New York 1998.
6. Bollen M. H. J., "Understanding Power Quality Problems: Voltage Sags and Interruptions", IEEE, Inc., New York 2000.
7. Gomez J. C., Morcos, M. M., Reineri C. A., Campetelli G. N., "Behavior of induction motor due to voltage sags and short interruptions", Power Delivery, IEEE Transactions, Volume: 17 Issue: 2, April 2002, Pages: 434-440.
8. Bollen M. H. J., "The influence of motor re-acceleration on voltage sags", Industry Applications Society Annual Meeting, 1994, Conference Record of the 1994 IEEE, 2-6 Oct. 1994, pp. 2235-2242 vol.3.
9. Dugan R. C., McGranaghan M. F., Santoso S., Beaty H. W., "Electrical Power Systems Quality", McGraw-Hill Companies, Inc., New York 2003.
10. Mohamed K., Mohamad N. H., "Digital Simulation of Uninterruptible Power Supply (Ups) and Dynamic Voltage Restorer (DVR) For Voltage Sag Mitigation", September 2001, Proceeding of the 2001 AUPEC, Perth, Australia, pp. 124-129.