

Haptic Rendering & Perception Studies For Laparoscopic Surgery Simulation

Ryan McColl, A/P Ian Brown, Cory Seligman, Fabian Lim, Amer Alsaraira
Electrical and Computer Systems Engineering
Monash University, Clayton, Victoria, 3800, Australia
Email: ryan.mccoll@eng.monash.edu.au

Abstract—This project concerns the application of haptic feedback to a virtual reality laparoscopic surgery simulator. Haptic attributes such as mass, friction, stiction, elasticity, roughness and viscosity are individually modeled, validated and applied to the existing visual simulation created by researchers at Monash University.

Validation studies has shown that refinements to our mechanical interface improves the accuracy of localisation by 25%. Using our mechanical interface, the JND (Just Noticeable Difference) for instantaneous change of magnitude of haptic attributes is approximately 12%. This suggests the mechanical interface is suitable to use for surgery based studies.

There are times in surgery when the view from the camera cannot be depended upon. When visual feedback is impeded, haptic feedback must be relied upon more by the surgeon. A realistic simulator should include some sort of visual impedance. Results from a simple tissue holding task suggested the inclusion of haptic feedback in a simulator aids the user when visual feedback is impeded.

Haptic force feedback modeling, systems implementation, threshold and level perception, and validation studies form the principal areas of new work associated with this project.

KEY WORDS

Haptic, Force Feedback, Surgery Simulation, Laparoscopy and Virtual Reality.

I. INTRODUCTION

The sense of touch provides critical information to surgeons when they are orientating themselves, diagnosing pathologies and manipulating tissue. In order to ensure a completely immersive and realistic VR simulator, haptic feedback must be included. Haptic feedback becomes especially useful when the feedback of vision becomes impeded in some way. This can occur during surgery. For example, the person holding the camera moves their arm; blood, smoke or an organ impedes the view; the rare occurrence of camera malfunction. To accommodate this, surgeons should therefore be trained to rely on their haptic senses as well.

Current laparoscopic surgery training techniques are primitive involving the use of expensive cadavers and animals, unrealistic training boxes or living humans. Making a cost effective yet realistic VR simulator available for training will enable increased training time, wider variety of procedures and offer objective performance feedback.

II. OVERVIEW OF CURRENT RESEARCH

Following on from the development of the haptic mechanical interface designed by Seligman [1] [2], the construction of a third prototype has been undertaken. Figure 1 shows the new mechanical interface. In terms of the software modeling, the coordinate system has been defined and simple procedures have been written to validate the ability for the interface to display a 3D force to the user [3]. An initial validation study has been undertaken in which a number of subjects have been tested to determine their ability to find the apex of a virtual sphere. It was found the new

haptic mechanical interface offers significant improvement over previous models. These results are shown in Section III. A threshold perception study was undertaken to test our interface and modeled haptic attributes. These results, including the JND for each attribute, are shown in Section VI. A study to determine when haptics is most useful in a simple tissue holding surgery based task has also been undertaken. These results are shown in Section VI.

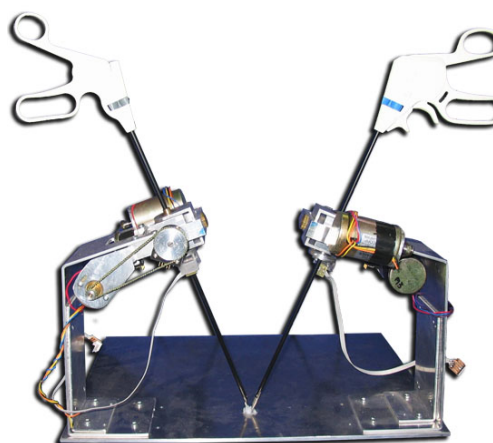

Fig. 1. The Mechanical Interface

A. Systems Model

Figure 2 provides an overview of the project in terms of information flow and I/O paths. The system has three major components: the *Human Operator*, the *Haptic Device*, and *Haptic Control and Virtual Environment Model*.

B. Mechanical Interface

The mechanical interface was designed and built by the authors [1] [3]. An overview of the gimbal construction and how it connects to the force feedback motors and mounting arm are shown in Figure 3.

III. PRELIMINARY VALIDATION

Initial tests ensured the haptic device displayed continual stable forces in 3 dimensions with magnitudes of approximately 6N. A study was undertaken to determine if the improvements made to the interface actually improved its haptic performance. The study involved subjects finding the apex of a virtual hemisphere placed randomly on a virtual horizontal plane using one haptic instrument. The virtual hemisphere radius was kept constant at 20mm, the same as a table tennis ball. Once the subject found the apex of the hemisphere, the tester stopped the simulation, recording the subjects coordinate values. Each subject was tested on 10 virtual hemispheres and 5 subjects in total were tested. To maintain consistency with previous results, the error of the subjects attempt to find the apex was calculated as a percentage of the radius for both the x and y axis. The mean error was 21.7% with the standard deviation 13.5. This suggests a marked improvement

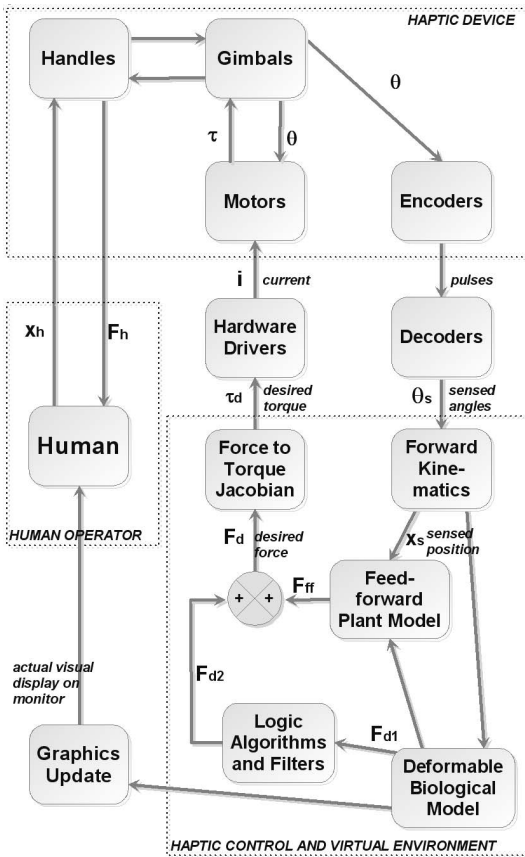

Fig. 2. Block Diagram - System Overview

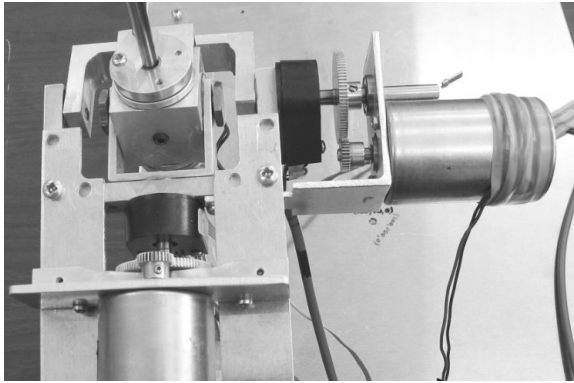

Fig. 3. Overview of Gimbal

from previous results (mean error of 29.7%) indicating that the new haptic interface, with a threefold increase in force capabilities, greatly improves a users ability to navigate a virtual environment. A plot of results can be found in Figure 4.

IV. HAPTIC FORCE FEEDBACK DC MOTORS

The method of transferring force between the motors and the user required several modifications. Initially a string belt type pulley system was utilised which increased the motors torque capabilities by 3 times. Unfortunately at moderate forces the string belts slipped causing non-smooth force transfer. A non slip grooved belt and pulley system was constructed which initially tested well, but it was found when operating near the maximum force regions, the tension required for the belts not to slip caused a mechanical misalignment in the gimbal, increasing friction to unreasonable levels.

Tests were done on the motors to determine whether or not they

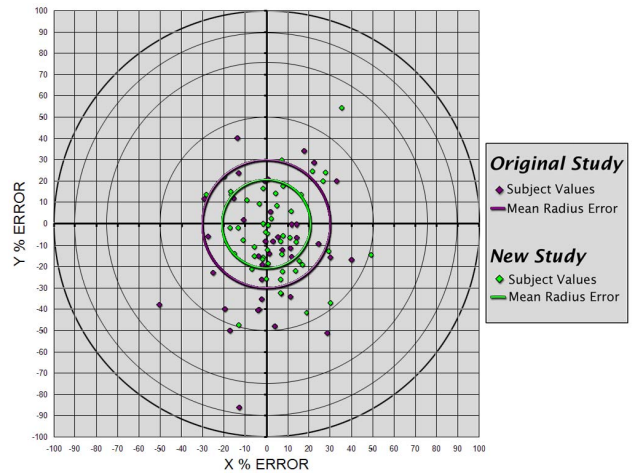

Fig. 4. % Error In Locating Virtual Spheres

could be directly coupled to the gimbal axis. This overcomes the disadvantages of backlash with gears and belt stretch with pulleys. A 100W motor-amplifier combination was able to create just over 2N peak force to the user. From the virtual sphere location study, it was deemed 2N was insufficient to obtain the navigational accuracy desired. Therefore a 3:1 geared setup was constructed which could supply peak forces of over 6N. Backlash is minimal and should not detract from the users experience.

The navigational results found by increasing available force output correspond with findings from O'Malley and Goldfarb, that suggest maximum forces of 3-4N need to be displayed in order to achieve good performance in perception tasks [4]. We have planned further studies to investigate how forces of up to 6N aid in performance tasks based on surface properties such as friction and stiction.

V. HAPTIC MODELING

Haptic modeling consists of the creation of models to generate virtual haptic forces, the realisation of these models, and model validation in the context of the overall simulation.

A. Coordinate System

The gimbal allows instrument movement in four degrees of freedom (H,P,R,D). In the current hardware implementation, the *H* axis (heading) reflects rotation of the instrument left and right, the *P* axis (pitch) represents rotation forward and back, the *R* axis (roll) represents rotation of the handle about its own axis and the *D* axis (depth) represents axial movement of the instrument through the centre of the gimbal. Cartesian coordinates (*X,Y,Z*) are used by the visual loop and relationships must be made in order to pass information between visual and haptic loops. A Cartesian normal surface vector is passed from the visual loop when contact is made between an instrument and an object. This is converted to a force vector based on attributes of the organ, such as mass or deformation. In order to display this force to the user through the mechanical interface, the Cartesian vector must be separated into polar coordinates, which allows the signals for the force feedback motors to be generated.

B. Object Oriented Modeling

The initial models are based on a simple object oriented approach which lends itself neatly to the addition of new objects and features into the VR model. Haptic attributes, such as elasticity, mass, deformation, roughness, friction, stiction and viscosity, are used as building blocks to define the overall properties of anatomical objects. The attributes have been individually modeled in software and validated using human subjects. Results can be found in Section

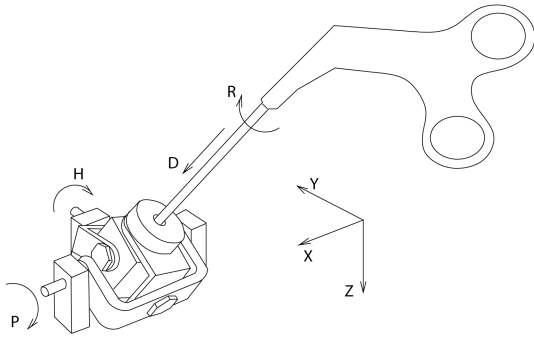

Fig. 5. The Coordinate System

VI. The attributes are combined to create the overall properties of an object. An ovary, for example, has the individual attributes of mass, deformability, roughness and friction.

C. Programming the Attributes

Simplification of attributes is essential in maintaining a real time system. Maintaining the physical properties and principles of inertia for anatomical objects is impossible without some quantisation of both shape and time. Finding a balance in enhancing users training value without detracting from the overall simulation speed remains an active area of research.

The property of weight is simply the mass of the object multiplied by gravity, resulting in a unidirectional constant force. The forces associated with accelerating a mass have been included but are very small due to the small masses of objects and slow acceleration rates encountered during laparoscopic surgery.

A representation of both viscosity and stiction has been achieved using the following algorithm:

- When contact is made between the Tool Tip (*TT*) and an object, store the Point Of Contact (*POC*). Note that inside viscous liquid, the *TT* is always touching an object.
- As the *TT* moves away from the *POC*, apply a force to the *TT* in the direction of the *POC* based on the distance between the two points.
- Whilst the *TT* remains in contact with the object, the *POC* moves towards the *TT* at a speed based on the distance between the two points.
- Once the *TT* is no longer geometrically touching the object, a force is maintained for a length of time based on distance between the *POC*. This ensures there remains some physical contact, or stiction.
- Properties can be varied greatly by adjusting parameters related to distance, speed and time.

VI. VALIDATION

A. Threshold Perception Study

AIM: To validate the haptic attributes it is essential to undertake studies to determine what the JND is for each attribute. This ensures both that we do not unnecessarily display forces that cannot be perceived, and that our mechanical interface accurately reproduces forces to users and is suitable for further studies into surgery based haptic tasks.

OVERVIEW: Studies have shown humans can detect change in forces of approximately 10% through their fingers [5] [6] [7]. Subjects must be tested using our mechanical interface to ensure they can detect force changes of approximately 10%. Findings otherwise would suggest the construction of our interface is not suitable for further surgery based studies.

The validation of subjects ability to detect changes in haptic attributes is more difficult to quantitatively measure, as equations

used to model attributes vary from the physical world. A simple way to achieve validation is to determine what the JND for force is through the changing of parameters in the attribute equations. For example, if subjects can detect a change in viscosity of 10%, what force difference enabled this detection?

The motivation for the study has also come partially from a related hysteroscopic simulation project. Due to the limited visual cues available in comparison to laparoscopic surgery, hysteroscopic surgery demands greater reliance on tactile senses. Often, this type of surgery requires locating pathologies on the uterus wall. Sometimes they cannot be seen via the camera and must be detected only by tactile sense. The individual haptic attributes utilised in finding a pathology may include elasticity, friction, slipperiness and stiction.

METHOD: The following perceptions were undertaken with each subject: mass perception, soft tissue elasticity, surface stiction, liquid viscosity and detection of a heart beat (displacement).

Following familiarisation and a trial run, subjects were tested 30 times for each attribute, 10 times for each of 3 default levels. The increment and direction of the changes were randomly generated. A computer generated tone sounded each time the attribute changed. Subjects were then given a chance to determine if a change occurred. 5 male subjects aged 20-35 in total were tested.

RESULTS: The average JND for mass was 12.5%. The smallest change detectable from a zero base was 0.13N. The instrument has a weight of 100N, and therefore about a zero base, JND was 13%. For a base force of 1.25N, JND was 12.5% and for a base of 2N, JND was 12%.

The JND for an elastic membrane with stiffness of 100N/m and 500N/m was 10%. For a stiffness of 1500N/m, JND was 16.7%.

The average JND for stiction was 13%. A change in stiction parameters is proportional to a change in force for a given velocity. Each subject has control over their velocity during this experiment so the JND is based on both force and velocity.

The average JND for viscosity was 8%. As with the stiction calculations, force change is proportional to viscosity change, but forces generated depend on the velocity of the instrument.

Subjects were able to detect, on average, 5% changes in the height of a simulated heart beat. The heart beat is modeled as a height changing membrane with stiffness of 1000N/m. Perception is dependent on users ability to detect both a change in force and change in displacement.

The overall JND for purely force related tests is approximately 12%. This suggests our interface is suitable for use with surgery based tasks. The higher JND for the high stiffness membrane suggests the mechanical limitations of the interface may be being approached. The remaining attributes tested depend on force perception and either velocity or displacement perception. Further studies are required to comprehend further, but low percentage JND's suggest our modeling techniques provide measurable information to users which can be applied to deformable visual graphic models. A full statistical analysis is yet to be completed but the trends found warrant further research into this area.

B. Object Localisation Study

AIM: The aim of this study is to test the value of various modes of haptic/visual feedback in a simulated MIS (Minimally Invasive Surgery) task. It investigates localisation of an anatomical object to a spatially known location. Several studies, for example [8] and [9], investigate performance tasks with constant and continual visual feedback. This study investigates whether performance of a task is effected if the visual feedback is still present, but impeded slightly as is possible during surgery.

OVERVIEW: Subjects are given an opportunity to initially localise the instrument to the desired position using an active visual graphic position monitor. The active monitor is removed and subjects must rely on the modes listed below to relocate the instrument to the desired position. 10 male subjects aged 20-35 in total were tested.

Modes of visual/haptic feedback:

- None (limb localisation feedback only)
- Fixed Viewpoint Visual Feedback (FVF)
- Haptic Feedback (HF)
- Fixed Viewpoint Visual & Haptic Feedback (FV&HF)
- Varying Viewpoint Visual Feedback (VVF)
- Varying Viewpoint Visual & Haptic Feedback (VV&HF)

Visual feedback displays to the user a virtual view of the mechanical instrument inside the virtual abdomen. The camera view point is located similarly to the position of a real camera during surgery.

The FVF displays the scene from a fixed viewpoint. Subjects are able to take advantage of the view point being fixed and visually line up the instrument with tokens on the monitor. This is deemed to be realistically inaccurate as cameras are not necessarily held steady.

The VV displays the scene from a camera randomly drifting in 3 axis. Observation of surgery suggests this is more realistic than a FV model.

HF displays a force to the user. A simple elastic model is used for the object being stretched. The desired position represents a movement of 60mm from the initial position, generating a force of 2.5N.

No feedback indicates no visual or haptic feedback. Subjects eyes are covered and haptic feedback is switched off. The ability to locate the instrument is based purely on the ability of the subject to localise themselves using the sensed angle of their shoulder, elbow and wrist joints. This provides a benchmark for other modes.

METHOD: Following familiarisation and a trial run, subjects perform the localisation task five times with each feedback mode. After the five attempts, subjects stand and walk around. They then localise themselves again using the active position monitor under the new feedback mode conditions. The whole experiment is performed twice per subject.

RESULTS: The percentage error in locating to the desired position without visual or haptic feedback is approximately 15%.

With FVF only the percentage error in locating is approximately 6%. With VVF only the percentage error in locating is approximately 8%. The difference makes sense as it is more difficult to locate something using vision if your frame of reference is changing.

Haptics alone measured a percentage error in locating of approximately 8%. Not as good as fixed viewpoint visual feedback but still much better than using limb localisation feedback only.

The most interesting result is the combination of visual and haptic feedback. With FV&HF the percentage error in locating is still approximately 6%. This suggests haptics neither detracts nor adds to the ability to locate when the visual feedback is fixed. With VV&HF the percentage error is approximately 6%. A 2% improvement on both VVF & HF alone. This suggests haptics aids in the ability to locate an object when the visual view point is changing.

A plot of results can be found in Figure 6. A full statistical analysis is yet to be completed. This is an initial validation study showing trends that warrant further research into this area.

VII. DISCUSSION & CONCLUSION

Studies are required to validate new haptic hardware and software to ensure its suitability for the use it was designed for. Our mechanical interface has been validated using a navigation study

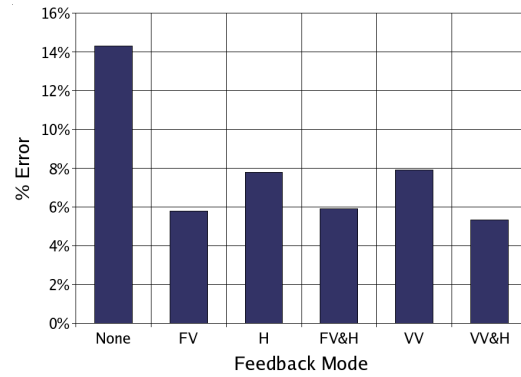

Fig. 6. Object Localisation

and a perception study measuring the JND of forces displayed to the user. Haptic attribute models operate at real time and provide measureable information to users. We believe our system is suitable for further studies in the context of surgery simulation.

A tissue localisation study was conducted which compared performance using different modes of feedback. Results suggested that including haptic information to subjects improved their ability to locate tissue to a known position when visual feedback was impeded.

The researchers are currently engaged in the introduction of haptics into a virtual reality based laparoscopic simulator. The development of haptic rendering hardware and software has identified a number of important engineering design challenges. Solutions to these challenges need to be both cost effective and computationally efficient. Global physical modeling may produce a single virtual organ with realistic visual and haptic properties but a multi-organ, multi-instrument, multi-operator simulation suggests a less global, more segmented object oriented approach. This approach is currently being investigated in relation to the haptic rendering of a VR laparoscopic simulator.

REFERENCES

- [1] C. Seligman, "Force Feedback Haptics for Virtual Reality Laparoscopic Surgery," Master's thesis, Monash University, Department of Electrical and Computer Systems Engineering, Clayton, Australia, 2003.
- [2] I. Brown, C. Seligman, Z. Mayoaran, and D. Healy, "Haptic Rendering In A Virtual Reality Based Endoscopic Simulator," in *Engineering and the Physical Sciences in Medicine*. Geelong, Australia: EPSM, 2004.
- [3] R. McColl, I. Brown, C. Seligman, F. Lim, and A. Alsaraira, "Haptic Rendering For VR Laparoscopic Surgery Simulation," in *Engineering and the Physical Sciences in Medicine*. Adelaide, Australia: EPSM, 2005.
- [4] M. K. O'Malley and M. Goldfarb, "The Effect of Force Saturation on the Haptic Perception of Detail," *Mechatronics, IEEE/ASME Transactions on*, vol. 7, no. 3, pp. 280 – 288, Sept. 2002.
- [5] X.-D. Pang, H. Z. Tan, and N. I. Durlach, "Manual Discrimination of Force Using Active Finger Motion," *Perception & Psychophysics*, vol. 49, no. 6, pp. 531 – 540, 1991.
- [6] C. Doerrer and R. Werthschuetzky, "Simulating Push-Buttons with a Haptic Display: Requirements of Force Resolution and Force-Displacement Curve," in *Proceedings of EuroHaptics 2002*, Edinburgh, UK, 2002.
- [7] S. Allin, Y. Matsuoka, and R. Klatzky, "Measuring Just Noticeable Differences for Haptic Force Feedback: Implications for Rehabilitation," in *IEEE Haptics Interfaces For Virtual Envir. & Teleoperator Sys.*, Apr. 2002.
- [8] M. Jones, A. Bokinsky, T. Tretter, and A. Negishi, "A Comparison of Learning with Haptic and Visual Modalities," *Haptics-e, The Electronic Journal of Haptics Research (www.haptics-e.org)*, vol. 3, no. 6, May3, 2005.
- [9] L. Moody, C. Baber, and T. Arvanitis, "The Role of Haptic Feedback in the Training and Assessment of Surgeons using a Virtual Environment," in *Proc. Eurohaptics 2001*, Univeristy of Birmingham, UK, 2001.