

# Origins of the sex differences in handedness and mental rotation ability: genetic, environmental and hormonal effects

**Eero Vuoksima**



Institute of Behavioural Sciences and Department of Public Health, Hjelt Institute  
University of Helsinki, Finland

Academic dissertation to be publicly discussed  
by due permission of the Faculty of Behavioural Sciences  
at the University of Helsinki in Auditorium PIII, Yliopistonkatu 3  
on the 10th of December, 2010, at 12 o'clock

UNIVERSITY OF HELSINKI  
Institute of Behavioural Sciences  
Studies in Psychology 72: 2010

Supervisors: Professor Jaakko Kaprio, MD, PhD  
Department of Public Health,  
Hjelt-Institute  
and Institute for Molecular Medicine  
University of Helsinki, Finland;  
Department of Mental Health  
and Substance Abuse Services,  
National Institute for Health and Welfare  
Helsinki, Finland

Docent Laura Hokkanen, PhD  
Institute of Behavioural Sciences  
University of Helsinki, Finland

Reviewers: Docent Iiro Jääskeläinen, PhD  
Department of Biomedical Engineering  
and Computational Science  
Aalto University, Finland

Associate professor Valerie Knopik, PhD  
Department of Psychiatry and Human Behavior,  
and Department of Community Health,  
Warren Alpert School of Medicine  
Brown University, USA;  
Division of Behavioral Genetics,  
Department of Psychiatry,  
Rhode Island Hospital, USA

Opponent: Professor Dorret Boomsma, PhD  
Department of Biological Psychology  
Vrije Universiteit Amsterdam, The Netherlands

ISSN 1798-842X  
ISSN-L 1798-842X  
ISBN 978-952-10-6653-5 (pbk)  
ISBN 978-952-10-6654-2 (PDF)  
<http://www.ethesis.helsinki.fi>  
Helsinki university print  
Helsinki 2010

# Contents

<b>Abstract</b> .....	<b>5</b>
<b>Tiivistelmä</b> .....	<b>6</b>
<b>Acknowledgements</b> .....	<b>7</b>
<b>List of Original Publications</b> .....	<b>9</b>
<b>Abbreviations</b> .....	<b>10</b>
<b>1 Introduction</b> .....	<b>11</b>
1.1 Handedness as a measure of laterality.....	12
1.1.1 Sex difference in handedness.....	13
1.1.2 Genetic effects on handedness.....	14
1.1.3 Testosterone effects on handedness.....	15
1.1.4 Environmental effects on handedness.....	17
1.2 Mental rotation ability as a measure of male favoring spatial ability.....	17
1.2.1 Sex difference in mental rotation ability.....	18
1.2.2 Genetic effects on mental rotation ability.....	19
1.2.3 Testosterone effects on mental rotation ability.....	20
1.2.4 Environmental effects on mental rotation ability.....	21
1.3 Prenatal masculinization and prenatal transfer of testosterone.....	23
1.3.1 Comparing females with male co-twins to females with female co-twins: an indirect measure of prenatal exposure to elevated levels of testosterone?.....	24
1.3.2 Postnatal socialization as an alternative explanation for masculinization....	28
<b>2 Aims of the study</b> .....	<b>30</b>
<b>3 Methods</b> .....	<b>31</b>
3.1 Participants.....	31
3.1.1 Older Finnish Twin Cohort.....	31
3.1.2 FinnTwin12.....	32
3.2 Measures.....	32
3.2.1 Handedness measures.....	32
3.2.2 Mental Rotation Test.....	33
3.2.3 Hormonal measures.....	34
3.2.4 Other measures.....	34
3.3 Statistical analyses.....	35
3.3.1 Modeling of genetic and environmental effects in twin data.....	35
3.3.2 Other statistical analyses.....	37
<b>4 Results</b> .....	<b>39</b>

4.1 Sex differences in left-handedness.....	39
4.2 Genetic and environmental effects on handedness .....	40
4.3 Prevalence of left- and right-handedness in twins from opposite- and same-sex pairs .....	40
4.4 Activational levels of sex hormones and handedness.....	41
4.5 Pregnancy and birth related variables and handedness .....	41
4.6 Sex difference in the mental rotation test.....	42
4.7 Genetic and environmental effects on mental rotation test.....	43
4.8 Mental rotation performance in twins from opposite- and same-sex pairs.....	43
4.9 Computer game playing experience and mental rotation test performance.....	44
4.10 Pregnancy and birth related variables and mental rotation performance.....	46
4.11 Additional evidence to support the prenatal origin of masculinization of mental rotation performance in females with male co-twins.....	47
<b>5 Discussion.....</b>	<b>50</b>
5.1 Sex differences in handedness and mental rotation performance.....	50
5.2 Genetic and environmental effects on handedness and mental rotation ability ..	51
5.3 Prenatal testosterone effects on handedness and mental rotation ability – or are the results explained by postnatal effects?.....	53
5.4 Birth and pregnancy related variables .....	58
5.5 Methodological considerations .....	59
<b>Conclusions .....</b>	<b>61</b>
<b>6 References .....</b>	<b>62</b>

## Abstract

In humans, well-replicated and robust sex differences in cognitive functions exist for handedness and mental rotation ability. A common characteristic in human cognitive functions is the lateralization of language functions. Handedness is a common measure of laterality and is related to language lateralization. The prevalence of left-handedness is higher in males than in females, the male to female ratio being about 1.2. Among cognitive abilities, the largest sex difference is evident in the Vandenberg and Kuse Mental Rotation Test (MRT), which requires the ability to rotate objects in mental space. On average, males achieve scores one standard deviation higher than females in the MRT.

The present thesis investigated the origins of the sex differences in laterality and spatial ability as represented by handedness and mental rotation ability, respectively. Two population-based Finnish twin cohorts were utilized in this study. Handedness was studied in 25 810 twins and 4068 singletons born before 1958 from the Older Finnish Twin Cohort, and in 4736 twins born in 1983-87 from the FinnTwin12. MRT was studied in a sub-sample of 804 young adult participants from the FinnTwin12 sample.

The main findings of this study were: 1) the prevalence of left-handedness was higher among males than among females in both singletons and in twins; 2) males had significantly higher scores than females in MRT; 3) about one quarter of the variance in handedness and about half of the variance in MRT was explained by genetic effects, whereas the remainder of the variance in these traits was explained by environmental effects unique to each individual. The magnitude of the genetic effects was similar in both sexes; 4) left-handedness was significantly less common in female co-twins of a male than in female co-twins of a female, and female co-twins of a male scored significantly higher than did female co-twins of a female in the Mental Rotation Test.

This dissertation discusses whether these differences between females from opposite- and same-sex twin pairs are due to the prenatal transfer of testosterone from the male fetus in females with male co-twins or whether they arise from postnatal socialization effects.

## Tiivistelmä

Kognitiivisten toimintojen alueella kaksi selkeää sukupuolieroa ilmenevät kätisyydessä ja avaruudellisen hahmottamisen kyvyssä pyörittää (rotatoida) mielensisäisesti kappaleita. Ihmisen kognitiivisille toiminnoille yleinen piirre on kielen lateralisaatio aivoissa. Kätisyys on usein käytetty lateraalisuuden mittari ja se on yhteydessä kielen lateralisaatioon. Vasenkätisyys on noin 1,2 kertaa yleisempää miehillä kuin naisilla. Kognitiivisten kykyjen alueella suurin sukupuoliero on havaittu Mental Rotation Testissä (MRT), joka mittaa kykyä pyörittää mielensisäisesti kappaleita. Miesten keskimääräinen tulos MRT:ssä on noin yhden keskihajonnan suurempi kuin naisilla.

Tässä väitöskirjassa tutkittiin sukupuolierojen alkuperää lateraalisuudessa ja spatiaalisessa hahmottamisessa, joita tässä tutkimuksessa edustivat kätisyys ja MRT. Tutkimuksessa käytettiin kahta suomalaista väestöpohjaista kaksosaineistoa: kätisyyttä tutkittiin aineistolla, jossa oli mukana 25 810 ennen vuotta 1958 syntyneitä kaksosta ja 4068 ei-kaksosta sekä kaksosten kehitys ja terveys –tutkimus (FT12) aineistolla, jossa oli mukana 4736 vuosina 1983-87 syntyneitä kaksosta. MRT:tä käsitteviin tutkimuksiin osallistui 804 nuorta aikuista kaksosta, jotka osallistuivat syventäviin tutkimuksiin osana kaksosten kehitys ja terveys -tutkimusta.

Tärkeimmät tulokset olivat: 1) vasenkätisyys oli miehillä yleisempää kuin naisilla, niin kaksosilla kuin ei-kaksosillakin; 2) mieskaksoset suoriutuivat naiskaksosia paremmin MRT:ssä; 3) sekä naisilla että miehillä noin neljännes kätisyydessä esiintyvistä vaihtelusta ja noin puolet MRT:ssä esiintyvistä vaihtelusta selittyivät geneettisillä tekijöillä, yksilöille erilaisten ympäristötekijöiden selittäessä loput näissä ominaisuuksissa esiintyvistä vaihtelusta; 4) vasenkätisyys oli harvinaisempaa naisilla joilla on kaksosveli kuin naisilla joilla on kaksossisar ja lisäksi naiset joilla on kaksosveli suoriutuivat MRT:ssä merkitsevästi paremmin kuin naiset joilla on kaksossisar.

Tämän tutkimuksen perusteella ei voida varmasti sanoa, että johtuvatko viimeksi mainitut erot siitä, että naiskaksoset joilla on veli saattavat altistua kohdussa kaksosveljen tuottamalle testosteronille vai siitä, että syntymän jälkeinen kasvuympäristö on erilainen naisilla joilla on kaksosveli kuin naisilla joilla on kaksossisar.

## Acknowledgements

This work was carried out at the Department of Public Health, Hjelt-institute, University of Helsinki. I thank the former head of the department, professor Jaakko Kaprio and the present head of the department, Ritva Halila for providing the research facilities. I am grateful to financial support from Finnish Cultural Foundation (Arvo and Helvi Lehtovaara Fund). I also acknowledge the travel money that I received from the Emil Aaltonen Foundation, University of Helsinki Jubilee Fund, University of Helsinki Chancellor, and Behavior Genetics Association.

I am most grateful to my supervisor, professor Jaakko Kaprio, the principal investigator of Finnish twin studies at the University of Helsinki, for giving me opportunity to use the excellent data from the FinnTwin12 and older Finnish twin cohort studies. I appreciate Jaakko for giving me a freedom to choose my study approach. Jaakko has created an encouraging and stimulating atmosphere for conducting my studies.

I thank my other supervisor, PhD Laura Hokkanen from the Institute of Behavioural Sciences, University of Helsinki. Her contribution especially on the studies on Mental Rotation was highly valuable.

Although not my official supervisor, a very important person for my career as a researcher has been professor Richard Rose from Indiana University, Bloomington, USA. He has been a perfect mentor at every stage of my PhD studies. Always encouraging and ready to help with any questions. Besides his professional expertise I have enjoyed our friendship. You are such a good role model showing how to combine outstanding science career and family life!

I want to express my thanks to Annamari Tuulio-Henriksson. I thank you for choosing me to become tester for the Finnish twin studies – that is how I was introduced to twin studies at the Department of Public Health. You have been very supportive at every stage of my career. I also enjoyed participating the research seminar for PhD students at the National Institute for Health and Welfare led by Annamari Tuulio-Henriksson and Jaana Suvisaari.

I would like to thank the following persons for their contribution on separate papers: PhD Peter Eriksson, professor Markku Koskenvuo, professor William Kremen, professor Lea Pulkkinen, and professor Richard Viken.

I am thankful to associate professor Valerie Knopik and docent Iiro Jääskeläinen for reviewing this thesis, and professor Kimmo Alho for being supervising professor at the Institute of Behavioural Sciences.

Thanks for all who have participated in the data collection and managing in Finnish twin studies at the department of public health: Anja, Eila, Kristiina, Mari, Marja, Pia, Terttu, Ulla and everyone who is not mentioned here. I thank Annina, Sanna, Sini, and Timo for collecting the MRT data. Special thanks to Kauko, who has been very helpful in any questions concerning the data sets. I have also enjoyed to be in company of people in the twin research unit coffee group during these years.

Special thanks to all twins who have participated in the Finnish twin studies at the department of public health, University of Helsinki.

I want to express my gratitude to my parents Eeva and Kalevi for their support in my career and life in general. Thanks also to my parents-in-law Leena and Erkki for all their support.

Greatest thank goes to my family. I thank my favorite psychologist, absolute wife, Ulla for all love and support and my perfect daughter Eira. She is the one who really motivated me to hurry with my dissertation!

Helsinki, 30.9.2010

Eero Vuoksima



## List of Original Publications

The thesis is based on the following publications, referred to in the text by Roman numerals (I-V).

- I Vuoksima, E., Koskenvuo, M., Rose, R. J., & Kaprio, J. (2009). Origins of handedness: A nationwide study of 30 161 adults. *Neuropsychologia*, *47*, 1294-1301.
- II Vuoksima, E., & Kaprio, J. (2010). Sex differences in left-handedness are also evident in Scandinavia and in twins: Comment on Papadatou-Pastou, Martin, Munafò, and Jones (2008). *Psychological Bulletin*, *136*, 344-347.
- III Vuoksima, E., Eriksson, C. J. P., Pulkkinen, L., Rose, R. J., & Kaprio, J. (2010). Decreased prevalence of left-handedness among females with male co-twins: Evidence suggesting prenatal testosterone transfer in humans. *Psychoneuroendocrinology*, *35*, 1462-1472.
- IV Vuoksima, E., Kaprio, J., Kremen, W. S., Hokkanen, L., Viken, R. J., Tuulio-Henriksson, A., & Rose, R. J. (2010). Having a male co-twin masculinizes mental rotation performance in females. *Psychological Science*, *21*, 1069-1071.
- V Vuoksima, E., Viken, R. J., Hokkanen, L., Tuulio-Henriksson, A., Rose, R. J., & Kaprio, J. (2010). Are there sex differences in the genetic and environmental effects on mental rotation ability? *Twin Research and Human Genetics*, *13*, 437-441.

The articles are reprinted with kind permission of the copyright holders.

## Abbreviations

A	additive genetic effects
AIC	Akaike's Information Criterion
C	common environmental effect
CI	confidence intervals
D	genetic dominance effects
df	degrees of freedom
DZ	dizygotic
E	unique environmental effects
EHI	Edinburgh Handedness Inventory
F	F-value, parameter value in adjusted Wald-test
FT12	FinnTwin12, Finnish twin study of five birth cohorts born in 1983-1987
LH	left-handed
M	mean
MRT	Mental Rotation Test
MZ	monozygotic
OR	odds ratio
OSF	females from opposite-sex twin pairs
OSM	males from opposite-sex twin pairs
p	probability
RH	right-handed
SD	standard deviation
SSF	females from same-sex twin pairs
SSM	males from same-sex pairs
$\chi^2$	chi-square

# 1 Introduction

Among cognitive functions, a well documented sex difference exists in handedness: males are more likely to be left-handed (Papadatou-Pastou, Martin, Munafo, & Jones, 2008). Probably the most robust cognitive sex difference is a male advantage on mental rotation ability as measured with the Vandenberg and Kuse Mental Rotation Test (MRT) (Voyer, Voyer, & Bryden, 1995). The first documented cognitive sex difference in human life span occurs at the age of one day: male neonates showed greater interest in physical-mechanical object while female neonates preferred to look at a human face longer than the physical-mechanical object (Connellan, Baron-Cohen, Wheelwright, Batki, & Ahluwalia, 2000). This result concerning social cognition suggests that cognitive sex differences are not solely due to postnatal environmental effects.

Formation of handedness starts before birth during prenatal development: ultrasound studies have indicated that fetuses have right hand preference at 10 weeks of gestational age (Hepper, McCartney, & Shannon, 1998). Fetuses prefer to suck their right thumb throughout pregnancy (Hepper, Shahidullah, & White, 1991) and this preference is related to handedness at 10-12 years age (Hepper, Wells, & Lynch, 2005). With regard to spatial abilities, 2 month old infants have capacity to detect the three dimensional shape of rotating objects (Arterberry & Yonas, 2000; Johnson, Cohen, Marks, & Johnson, 2003). These results have demonstrated that origins of handedness and spatial abilities are at least partly determined at very early stages of life, probably before birth. Nonetheless, little is known about the factors that contribute in creating the sex differences in these two domains of cognitive functioning.

There has been a long debate on the origins of the human cognitive sex differences: are they caused by nature or nurture? As support for both biological and environmental causes has been documented, it is not fruitful to attribute cognitive sex differences solely to either nature or nurture. As with any other psychological trait, cognitive functions develop as an interplay between biological and environmental effects. Even so, the studies that focus on either biological or environmental effects on cognitive functions should not be prejudged on the basis of studying only biological or environmental effects as they often increase our knowledge on the origins of the sex

differences in cognitive domain. Of course, an ideal study would include information both on biological and environmental variables.

## **1.1 Handedness as a measure of laterality**

Handedness is a common measure of laterality and it is related to lateralized language processing in the human brain (Knecht et al., 2000). Although handedness is related to language lateralization, there is no perfect correspondence between these two traits: about 96% of strong right-handers do possess their language functions in contra-lateral left hemisphere, while in about 73% of strong left-handers, the language functions are also lateralized in the left hemisphere (Knecht et al., 2000). The prevalence of left-handedness varies in different studies by location and study population, but the current view among handedness researchers is that approximately 10% of people are left-handed. While many functions are lateralized also in animals (see Corballis, 2009), the 10% prevalence of left-handedness seems to be unique to humans, most likely reflecting the unique language abilities in humans (for different theories of handedness see e.g. Beaton, 2003).

One factor that has an impact on the estimates of the prevalence of left-/right-handedness is how handedness is measured. The estimated 10% proportion of left-handers is typically based on the writing hand. In the case of the writing hand, the rest of the people are right-handed while the prevalence of ambidextrous (those who perform the task equally well with left and right hand) people is under one percent (Perelle & Ehrman, 1994). But if handedness is measured with other tasks, like throwing a ball, then the prevalence of ambidextrous people is higher. Measures like writing and throwing hand are called preference measures, since they refer to individual's preference to use either one or both hands for the given task. Writing hand is usually treated as a dichotomous variable, but preference for writing (as well as for other tasks) can be indicated also by using, for example, a five point scale with always left/right hand and usually left/right hand and both hands alternatives. Also various handedness inventories have been used to measure hand preference. Measures like Edinburgh Handedness Inventory (EHI) (Oldfield, 1971) include several activities which are answered in five point scale and they yield continuous, although usually

highly skewed J-shape, distribution of handedness. Studies have used different cut points for handedness inventories, but there are not any a priori defined values and thus these cut points are usually arbitrary. Accordingly, the results are not always comparable between studies, and the results can be heavily dependent on the selected cut points.

Besides preference measures, handedness can be also treated as a performance measure. Various time-limited tasks have been developed to assess the relative hand skill. People perform certain tasks consecutively with right and left hand (or vice versa) and the difference score between right and left hand performance is then calculated to indicate relative hand skill. One commonly used measure is a peg-moving task (Annett, 1998), where a participant has to place pegs of a certain form into holes that have the corresponding form. The strength of the performance measures is that they can yield a normally distributed continuous variable, which provides more statistical power than a dichotomous variable on handedness studies.

### **1.1.1 Sex difference in handedness**

The two largest studies on handedness, one with over one million and the other with over 250 000 participants, have indicated that the prevalence of left-handedness is higher in males than in females (Gilbert & Wysocki, 1992; Peters, Reimers, & Manning, 2006). Due to low prevalence of left-handedness, some studies with small number of participants have lacked the power to detect this sex difference. In line with two large scale studies, meta-analysis of 144 studies indicated male to female odds ratio of 1.23 (95% confidence intervals 1.19 – 1.27) for left-handedness. Based on this meta-analysis, left-handedness is more common in males than in females in most geographical locations with the exception of Finland and Scandinavian countries where the prevalence of left-handedness do not differ between males and females (Papadatou-Pastou et al., 2008). Other meta-analysis of sex differences in left-handedness reported male to female odds ratio of 1.25 (Sommer, Aleman, Somers, Boks, & Kahn, 2008).

### 1.1.2 Genetic effects on handedness

Two genetic theories of handedness have suggested a model where a single gene with two alleles is related to handedness by determining whether a person has strong liability to become right-handed or no liability to either left- or right-handedness (Annett, 1998; McManus, 1985). In the right-shift model these two alleles are called  $rs+$  (a liability towards right-handedness) and  $rs-$  (no liability to either side) (Annett, 1998). In the symmetric bimodal model the alleles are called D and C, indicating dextral or change liability, respectively (McManus, 1985). In the right shift model handedness is treated as a performance measure, usually measured with peg-moving task, while in symmetric bimodal model handedness is seen as a preference, usually in form of writing hand.

These single gene models of handedness have received much attention, but data on familial aggregation of handedness do not fully support these models. In a study of over 70 000 offspring, the prevalence of left-handedness was 26% when both parents were left-handed, 20% when one of the parents was left-handed and 10% when both parents were right-handed (McManus & Bryden, 1992).

Also several other genetic models of handedness have been proposed. The X-linked genetic theory has evolved to account for the known higher prevalence of left-handedness in males (Jones & Martin, 2000). In a model by Martin and Jones, an exact estimate for the size of the sex difference has been introduced (Jones & Martin, 2010), but this do not seem to fit the observed data (for a critique see Corballis, 2001; McManus, 2010).

Many twin studies have indicated little or no genetic effects on handedness, but due to small sample sizes have been inadequate to answer the question of the proportion of genetic effects on handedness. A meta-analysis of 35 studies revealed that about quarter of the variance on handedness was explained by additive genetic effects while the rest of the variance was explained by environmental effects that are unique to each individual (Medland, Duffy, Wright, Geffen, & Martin, 2006). Recently, the result of the meta-analysis has been replicated in Australian and Dutch samples with 25 732 families, where genetic effects explained also 25% of the variance in handedness (Medland et al., 2009). Earlier twin studies have not taken into account the fact that

some individuals from the older cohorts might have been naturally left-handed, but have become right-handed writers due to forced right-handedness.

Many genetic mapping studies have used relative hand skill, measured with a peg moving task, as a phenotype (Francks et al., 2002; Francks et al., 2003; Francks et al., 2007; Laval et al., 1998), while three studies have used a preference measure of handedness: two studies with writing hand as a phenotype (Medland et al., 2005; Warren, Stern, Duggirala, Dyer, & Almasy, 2006) and one study with EHI as a phenotype (Van Agtmael, Forrest, & Williamson, 2002).

For relative hand skill, linkage on chromosome 2p12-q11 has been reported (Francks et al., 2003) and LRRTM1 gene on chromosome 2p12 is the first identified gene for relative hand skill (Francks et al., 2007). For hand preference, a suggestive linkage on chromosome 12q21-23 has been reported (Warren et al., 2006). Writing hand has been reported to be associated with androgen receptor gene (Xq11-12): GAC repeat length associated with lower levels of testosterone were related to left-handedness in healthy males and females (Medland et al., 2005).

### **1.1.3 Testosterone effects on handedness**

Two contradictory hypotheses on prenatal testosterone effects on handedness have been proposed. According to the Geschwind-Behan-Galaburda (GBG) hypothesis, high levels of prenatal testosterone increase the probability of left-handedness (Geschwind & Behan, 1982; Geschwind & Galaburda, 1985), which could explain the higher prevalence of left-handedness in males. In contrast, the callosal hypothesis links high levels of testosterone to right-handedness (Witelson & Nowakowski, 1991; Witelson, 1991). Although callosal hypothesis, which links anatomy of corpus callosum to handedness, was originally postulated to explain non-right-handedness in males as a result of lower than typical levels of testosterone (Witelson & Nowakowski, 1991; Witelson, 1991), the later studies have expanded the theory to explain right-handedness both in males and females as a result of exposure to higher than typical levels of testosterone.

GBG hypothesis has gained support from studies concerning females with congenital adrenal hyperplasia (CAH), a condition where a fetus is exposed to excessive levels of

testosterone. Two studies have indicated higher prevalence of left-handedness in females with CAH compared to controls (Kelso, Nicholls, Warne, & Zacharin, 2000; Nass et al., 1987), but in contrast two studies have found no difference in the rate of left-handedness between CAH and non-CAH females (Helleday, Siwers, Ritzen, & Hugdahl, 1994; Mathews et al., 2004).

Other evidence linking higher prenatal testosterone levels to left-handedness comes from studies that have used low (more masculine) second to fourth finger length ratio (2D:4D) as a putative marker of prenatal testosterone exposure (Manning, 2002). While studies have linked low 2D:4D ratio to left hand preference (Nicholls, Orr, Yates, & Loftus, 2008) or to enhanced left hand skill (Fink, Manning, Neave, & Tan, 2004; Manning, Trivers, Thornhill, & Singh, 2000), there are also contradictory findings: one study found that higher 2D:4D ratio was associated with left-handedness (Ypsilanti, Ganou, Koidou, & Grouios, 2008) and other study found that left-handedness was associated with low 2D:4D ratio in right hand, but high 2D:4D in left-hand (Manning & Peters, 2009). Also difference between right and left hand 2D:4D ratio is reported to be associated with handedness: left-handers have a higher right/left hand difference (Beaton, Rudling, Kissling, Taurines, & Thome, 2010; Manning & Peters, 2009).

The callosal hypothesis has been supported by the notion that males with Klinefelter syndrome, a clinical condition where male fetus is not producing testosterone, have higher prevalence of left-handedness than males in the normal population. In one study, the prevalence of left-handedness was 30% in males with Klinefelter (Ross et al., 2008). Two studies of healthy individuals have indicated that right-handed females have higher activational levels of testosterone, as measured from saliva sample, than left-handed females (Gadea, Gomez, Gonzalez-Bono, Salvador, & Espert, 2003; Moffat & Hampson, 1996b), and similar result has been reported also in males (Moffat & Hampson, 1996b). There are also studies that have not found any difference in activational testosterone levels between right- and left-handers (Beaton et al., 2010; Moffat & Hampson, 2000). The most convincing evidence linking prenatal testosterone and right-handedness comes from a study where prenatal testosterone was measured from amniotic fluid during second trimester: testosterone was positively correlated to stronger right-hand preference in healthy girls at age 10 (Grimshaw, Bryden, & Finegan, 1995).



#### **1.1.4 Environmental effects on handedness**

Some environmental effects have been reported to affect handedness. According to cross cultural data from 17 countries, the prevalence of left-handedness varied from one country to another, with the extreme prevalences of 2.5% and 12.8% in Mexico and Canada, respectively (Perelle & Ehrman, 1994). Subsequent analysis of these data revealed that the prevalence of left-handedness was lower in countries that were rated as formal cultures (Medland, Perelle, De Monte, & Ehrman, 2004).

In the meta-analysis of 144 studies, the prevalence of left-handedness varied as a function of cultural masculinity (Papadatou-Pastou et al., 2008), and it was stated that the lack of sex difference in left-handedness in Finland and Scandinavian countries might be a result of extreme low levels of cultural masculinity in these countries.

The prevalence of left-handedness has increased in western societies during 20<sup>th</sup> century, which is reflecting a fact that many left-handers were forced or encouraged to use their right hand in the early 20<sup>th</sup> century while the cohorts born in the latter half of the 20<sup>th</sup> century were not punished if they used their left hand.

Pathological left-handedness has been suggested to be at least partly due to environmental effects such as birth related complications (Williams, Buss, & Eskenazi, 1992) and viral infections (Ramadhani et al., 2006).

### **1.2 Mental rotation ability as a measure of male favoring spatial ability**

Among spatial abilities there are several sub categories including areas such as spatial visualization, spatial reasoning and spatial memory. One extensively studied area among spatial abilities is mental rotation ability and especially sex differences in this ability have been under extensive investigation.

There are several different kind of tests that measure mental rotation ability including both paper-and-pencil and computerized tests with two or three dimensional stimuli. Probably the most commonly used test is a paper-and-pencil administered Vandenberg and Kuse Mental Rotation Test (MRT) (Voyer et al., 1995), which in turn is based on the stimuli of Shepard and Metzler (Shepard & Metzler, 1971). In a typical

administration of the MRT, three dimensional target figures, built of small blocks, have to be matched to two rotated versions of the target figure, while each trial includes also two figures that cannot be matched with the target figure. MRT can be administered either individually or in a group testing.

### **1.2.1 Sex difference in mental rotation ability**

Among cognitive abilities, the most robust sex difference is evident in mental rotation tests, in which males outperform females. The largest effect size ( $d = 1.00$ ) is reported for Vandenberg and Kuse Mental rotation test (Voyer et al., 1995). Since the meta-analysis of Voyer et al. (1995), numerous individual studies have replicated the male advantage in MRT. A large scale internet study of MRT with over 200 000 participants indicated that males performed better than females in 53 out of 53 countries (Lippa, Collaer, & Peters, 2010). Similarly, the male advantage in MRT has been reported in different cultures also when the paper-and-pencil version of the test has been used (Peters, Lehmann, Takahira, Takeuchi, & Jordan, 2006). The largest sex difference arises when time limits are used in MRT, but the sex difference remains also when time limit is not used (Peters, 2005).

The sex difference in MRT exists across life span (Peters, Manning, & Reimers, 2007) appearing before puberty (Kerns & Berenbaum, 1991) already at the first year of life. In a study of infants at age 5 months males spent more time looking mirror-images of Shepard and Metzler MRT figures, whereas females spent equal time looking novel mirror-images and familiar stimulus (Moore & Johnson, 2008). This difference was interpreted as an indicator of male infants better ability to discriminate novel objects from familiar objects (Moore & Johnson, 2008). Another study documented sex difference in mental rotation test even earlier at ages 3-4 months, but this study did not use the Shepard and Metzler MRT stimulus (Quinn & Liben, 2008).

Due to early appearance and cross cultural existence of sex differences in spatial abilities evolutionary hunter-gatherer hypothesis of spatial abilities has been introduced to account for the fact that some spatial abilities, like mental rotation ability, are male favoring and some other spatial abilities, like memory for the location of objects, are female favoring (Silverman, Choi, & Peters, 2007).

### **1.2.2 Genetic effects on mental rotation ability**

To date, only one twin study of genetic and environmental effects on mental rotation ability has been reported (Vandenberg, 1969). That study indicated the heritability of mental rotation ability, but was not aimed to investigate sex differences in the magnitude of genetic effects on mental rotation ability. There are not any molecular genetic linkage, association or genomewide association studies on mental rotation ability.

In the 1970's several family studies investigated the parent-offspring correlations for spatial abilities, including Mental Rotation Test. Hawaii Family Study of Cognition indicated familial resemblance in MRT, in Americans of European and Japanese ancestry, with parent-child correlations ranging from .11 to .30, while the parent-child correlations ranged from .04 to .32 in Mainland Americans (DeFries et al., 1979). Another study of Mainland Americans have indicated similar parent-child correlations for MRT ranging from .16 to .23 (Bouchard & McGee, 1977), while the correlations in the study of Koreans were somewhat higher, ranging from .22 to .46 (Park et al., 1978). None of these family studies supported the view that MRT or spatial abilities in general are influenced by a sex-linked recessive gene, which has been suggested to explain the sex difference in spatial abilities (see e.g. Walker, Krasnoff, & Peaco, 1981). While these studies have reported familial resemblance in MRT, they were not designed to answer whether these familial effects are of genetic or environmental in origin.

Based on data on adoption, family, and twin studies, spatial abilities in general have substantial genetic influences, while the common environmental influences are of modest size (Plomin, DeFries, McClearn, & McGuffin, 2008). According to Colorado Adoption Project with data from adoptive and biological parents and their children at ages 3 to 16, the genetic effects in spatial abilities increase as a function of age (Plomin, Fulker, Corley, & DeFries, 1997), which indicates similar pattern to that of general cognitive ability (Plomin, Fulker, Corley, & DeFries, 1997; Haworth et al., 2009).

### **1.2.3 Testosterone effects on mental rotation ability**

Studies of CAH individuals have suggested that the permanent organizational effects of prenatal testosterone on spatial abilities favoring males, including mental rotation ability, differ between sexes: in females elevated levels of prenatal testosterone are related to better performance in male favoring spatial tests while in males elevated levels of testosterone are related to poorer performance in male favoring spatial abilities (Puts, McDaniel, Jordan, & Breedlove, 2008). Moreover, a study of healthy girls indicated a positive relationship between prenatal testosterone levels (measured from amniotic fluid at second trimester) and mental rotation test performance at age seven (Grimshaw, Sitarenios, & Finegan, 1995). In contrast, when these participants were four years old, girls who were in the low average group in block building performance had higher levels of prenatal testosterone, but no sex difference was evident in this spatial test and there were only four girls in the low average group (Finegan, Niccols, & Sitarenios, 1992).

Some studies have suggested that also activational effects of fluctuating levels of testosterone are related to spatial abilities differently in males and females with higher levels of testosterone reflecting better spatial abilities in females and poorer spatial abilities in males (Gouchie & Kimura, 1991; Moffat & Hampson, 1996a). There are also studies that have reported a positive relationship between activational levels of testosterone and mental rotation ability in males (Hooven, Chabris, Ellison, & Kosslyn, 2004). Some studies have also indicated that activational testosterone levels and spatial abilities, including mental rotation performance, are not related (e.g. Falter, Arroyo, & Davis, 2006; Matousek & Sherwin, 2010). Interestingly, a recent study of 160 females (who were taking hormonal contraception) and 177 males found no relationship between activational testosterone levels and Vandenberg and Kuse MRT neither in females or males (Puts et al., 2010). Further, all participants in that study were tested both on morning and evening sessions; the changes in the MRT performance between these two testing sessions were not related to testosterone levels. Authors of that study concluded that the lack of relationship between activational levels of testosterone and MRT are suggesting that the effects of testosterone on MRT, if they exist, are

organizational in origin and taking place at perinatal or pubertal developmental stages when testosterone secretion is highest in males (Puts et al., 2010).

To date, only one study has investigated the causal relationship of testosterone manipulation in healthy individuals: a single 0.5mg administration of testosterone improved mental rotation performance in a group of 14 females who received placebo prior to first testing session, whereas the group of 14 females who received testosterone before first testing did not show improvement in their second testing (Aleman, Bronk, Kessels, Koppeschaar, & van Honk, 2004).

#### **1.2.4 Environmental effects on mental rotation ability**

In addition to biological causes, several environmental effects are suggested to account for the evolving of the sex difference in male favoring spatial abilities, such as mental rotation performance. According to social role theory, sex differences arise from males and females different roles in society (Eagly & Wood, 1999; Wood & Eagly, 2002). An internet study with over 200 000 participants from 53 countries tested whether the national equality between sexes (as measured by United Nations Gender Equality Index) is related to sex difference in MRT performance. The results were opposite to the study hypothesis: gender equality was positively related to size of the sex difference in MRT performance showing that the largest sex difference was evident in countries with high gender equality score, like Norway, Australia and USA (Lippa et al., 2010). This result was interpreted in terms of stereotype threat theory (Steele, 1997), which states that females might perform poorer than males in certain visuo-spatial tests because they are aware of the pervasive stereotypes of males superior spatial abilities and thus they are exposed to negative emotions and anxiety while taking tests that measure spatial abilities. Females in countries with high gender equality would be more educated and more aware on studies concerning the sex differences in spatial abilities, thus leading to larger sex difference in MRT in these countries (Lippa et al., 2010).

In line with the stereotype threat theory, one study found that females who received negative information about females' poorer mental rotation ability prior to testing made significantly more errors than control group females who received no such information before performing mental rotation test (Wraga, Helt, Jacobs, & Sullivan, 2007). Further,

a group of females who were told that females have better perspective taking abilities than males (false, but reasonably postulated information) made significantly fewer errors than females in the control group. In support of the stereotype threat theory, functional magnetic resonance imaging revealed that females who received negative information prior to testing showed increased activity in areas that are related to processing of emotional information whereas highly activated areas in other females were those that are related to visuo-spatial processing (Wraga et al., 2007).

Besides the society's influences on macro level, the different social roles in males and females can result also from parenting within the family. Parents can also influence their children's cognitive skills by creating specific expectations about their children's abilities. Parents estimate their sons' intelligence quotient to be higher than their daughters' (Furnham, Reeves, & Budhani, 2002; Furnham & Valgeirsson, 2007). Interestingly one study found that parents estimated their sons' logical-mathematical and spatial intelligence to be higher than in their daughters' (Furnham et al., 2002). In line with parental ratings, females estimate of their own intelligence is significantly lower than males although this is not related to actual abilities (von Stumm, Chamorro-Premuzic, & Furnham, 2009).

Another socialization explanation for sex differences in spatial abilities comes from boys and girls differing exposure to sex-typed toys and activities. Parents encourage boys and girls into different sex-typed play (for a meta-analysis see Lytton & Romney, 1991). Some sex-typed activities and play experiences can improve performance in spatial tasks (for a meta-analysis see Baenninger & Newcombe, 1989). Studies have reported that computer game playing, activity that is more common in males, improves spatial abilities (Law, Pellegrino, & Hunt, 1993; McClurg & Chaille, 1987). Perhaps the sex differences in some spatial abilities would not be as large if females were engaged with more computer game playing: the effect of computer game practice on MRT performance has been reported to be significantly greater in females than in males (Quaiser-Pohl & Lehmann, 2002) and especially practice on action video game playing has been reported to reduce the sex difference in MRT (Feng, Spence, & Pratt, 2007).

### **1.3 Prenatal masculinization and prenatal transfer of testosterone**

Animal studies have clearly shown that prenatal androgen exposure has organizational effects on the sexual differentiation of the brain. The pioneering study of Phoenix, Goy, Gerall, & Young (1959) introduced organizational hypothesis whereby prenatal testosterone causes permanent masculinization of the brain in critical periods (Phoenix et al., 1959). The organizational effects refer to the prenatal period of differentiation when brain masculinization and feminization occurs, whereas activational effects refer to postnatal events when hormones activate the prenatally organized brain (Collaer & Hines, 1995). Development of male typical traits or behavior is called masculinization while development of female typical traits or behaviors is called feminization.

In short, the most important hormone in sexual differentiation of the brain is testosterone; the lack of testosterone leads to typical female brain development whereas exposure to testosterone masculinizes the brain (Arnold & Gorski, 1984; Breedlove, Jacobson, Gorski, & Arnold, 1982). However, estrogen also has an active role on brain sexual differentiation (Fitch & Denenberg, 1998) and also the role of genetically determined sexual differentiation of the brain has been recognized (Arnold et al., 2004; Arnold, 2009). When making interpretations of the effects of testosterone, one important point is that testosterone is converted to estradiol before it has its masculinizing effects on central nervous system (Janowsky, 2006). Thus, it is usually not known whether the testosterone's effects on cognitive functioning are resulting directly from testosterone or through the metabolism into other androgens or estradiol.

The effects of prenatal testosterone are also time dependent (Phoenix et al., 1959). For example, the same animal can be both masculinized and feminized if the prenatal exposure to testosterone occurs only in certain critical period (Roberts, Padmanabhan, & Lee, 2008). In animals, prenatal testosterone affects not only reproductive behaviors, but also other behaviors like spatial learning and rough and tumble play (Williams & Meck, 1991).

One source of prenatal masculinization in female animals occurs through prenatal transfer of testosterone from male littermates (for a review of masculinizing intrauterine position effect see Ryan & Vandenberg, 2002). The process of masculinization of

females varies in different species. In mice the females are masculinized if they are located adjacent to males (Ryan & Vandenberg, 2002), but in rats the masculinization effect occurs when male littermates are located caudally to female (Meisel & Ward, 1981). Females that are exposed to elevated levels of testosterone due to male littermates in their uterine environment have been reported to be masculinized in physiological and behavioral traits like aggression, anogenital distance, and mu-opioid receptors (Gandelman, vom Saal, & Reinisch, 1977; Morley-Fletcher, Palanza, Parolaro, Vigano, & Laviola, 2003).

### **1.3.1 Comparing females with male co-twins to females with female co-twins: an indirect measure of prenatal exposure to elevated levels of testosterone?**

In humans, the twinning rate and the proportion of dizygotic twins varies by ethnicity. In Finland, where the majority of people are Caucasians, about one percent of all births are twin births and one third of the twins are monozygotic, one third are dizygotic twins with same-sex co-twins, and one third of the twins are opposite-sex pairs (Kaprio & Marttila, 2005). This naturally occurring setting offers an interesting opportunity to test whether female members from opposite-sex pairs are masculinized compared to females from same-sex pairs. While prenatal transfer of testosterone from male littermates to females is evident in animals, there is not any direct evidence of prenatal transfer of testosterone from male to female fetus in human twin pregnancies.

Two alternative routes for possible prenatal transfer of testosterone from male to female are suggested: maternal-fetal and feto-fetal route (Miller, 1994). One study of mothers who were expecting twins indicated that maternal serum testosterone levels were not different in pregnancies with opposite- and same-sex twin pairs (Cohen-Bendahan, van Goozen, Buitelaar, & Cohen-Kettenis, 2005b), but that study measured maternal testosterone levels at 24 and 32 weeks of gestation, despite the fact that highest prenatal testosterone production in male fetuses is occurring from 8 to 24 weeks of gestation (Collaer & Hines, 1995). The maternal route is not supported by the fact that the hormone levels in maternal blood and amniotic fluid do not correlate (Nagamani, McDonough, Ellegood, & Mahesh, 1979). Even if the prenatal transfer of testosterone



would happen through maternal route, it would be impossible to detect by measuring maternal testosterone, because the sex of a fetus cannot be predicted from maternal testosterone levels (Abramovich, 1974).

The other suggested route for possible transfer of testosterone from male to female fetus goes directly from fetus to fetus. Amniotic fluid can permeate the fetal skin as well as placenta until 18 weeks from gestation (Abramovich & Page, 1972) and testosterone production in males is at highest before that gestational stage, with peak levels from 12 to 18, and from 14 to 16 weeks of gestation as measured from amniotic fluid and fetal serum, respectively (Abramovich, 1974; Nagamani et al., 1979; Reyes, Boroditsky, Winter, & Faiman, 1974; Warne, Faiman, Reyes, & Winter, 1977). Together, these facts suggests that there may be exposure to elevated levels of testosterone in female twins with male co-twins. If amniotic fluid from male fetus can enter the uterine environment outside male's fetoplacental unit due to its permeability then the female's placenta could act as a gateway for the access of extra testosterone. Testosterone from the male fetus would reach the female fetus through placenta, which could bind testosterone with its androgen receptors (Hirota et al., 1981), whereas testosterone is probably not capable of reaching the female fetus through its membranes, where androgen receptors are not found (McCormick, Razel, Spelsberg, & Coulam, 1981).

While testosterone levels in amniotic fluid differ remarkably between males and females (Nagamani et al., 1979; Warne et al., 1977), the sex of a fetus does not have effect on the estradiol levels in amniotic fluid (Warne, Reyes, Faiman, & Winter, 1978). In humans, the placenta has an active role on the regulation of hormones: it produces and secretes estradiol and regulates the amount of estradiol that enters fetal circulation (Drolet, Simard, Plante, Laberge, & Tremblay, 2007).

Unfortunately, there are no studies of amniotic fluid testosterone levels in twins from opposite- and same-sex pairs. Accordingly, the prenatal exposure to testosterone in females from opposite-sex pairs remains speculative.

Earlier studies comparing females with male co-twins and females with female co-twins have reported some evidence for masculinization for traits like eating disorders (Culbert, Breedlove, Burt, & Klump, 2008), maternal fitness (Lummaa, Pettay, & Russell, 2007), and otoacoustic emissions (sounds produced by inner ear) (McFadden, 1993), but many of these results have not been replicated (Medland et al., 2008;

Raeuori et al., 2008) and there are also negative results for other traits (e.g. Rose et al., 2002) (Table 1). Many of the studies have been conducted in small samples and many of the phenotypes are traits that have not been reported to be associated with testosterone in general.

**Table 1.** List of studies that have investigated masculinization of female twins from opposite-sex pairs.

Phenotype	Masculinization of OSF twins	Sample size	Publication	Additional information
<b>Biological traits</b>				
2D:4D ratio	+	56	van Anders et al., 2006	
	+	114	Voracek & Dressler, 2007	
	-	867	Medland et al., 2008a	
Dental asymmetry	+	148	Boklage, 1985	
Grip strength	-	4314	Gaist et al., 2000	
Maternal fitness	+	754	Lummaa et al., 2007	
	-	12295	Rose et al., 2002	
	-	2892	Medland et al., 2008b	
Spontaneous otoacoustic emissions	+	242	MacFadden, 1993	
Tooth crown size	+	149	Dempsey et al., 1999	
Total brain volume	+	119	Peper et al., 2009	Finding in 9-year olds. Not replicated in adult twins.

Psychological traits				
Disordered eating	+	582	Culbert et al., 2008	
	-	4388	Raevuori et al., 2009	
	-	2189	Baker et al., 2009	
Feminity-masculinity	-	5679	Rose et al., 2002	
Handedness	-	120	Elkadi et al., 1999	
	-	2262 and 1902	Ooki, 2005	
Mental rotation ability	+	Not reported	Cole-Harding et al., 1988	Appeared only as a meeting abstract.
Personality	-	5294 and 3006	Loehlin & Martin, 2000	
Proneness to aggression	+	129	Cohen-Bendahan et al., 2005a	
Right ear advantage	+	187	Cohen-Bendahan et al., 2004	Finding in 10-year olds, not replicated when the subjects were retested at age 13.
Sensation seeking	+	844	Resnick et al., 1993	
Sex-typed play	-	91	Henderson & Berenbaum, 1997	

OSF = females with male co-twins. + = positive finding for masculinization in females with male co-twins. - = negative finding for masculinization in females with male co-twins.

One often cited paper has reported masculinization of mental rotation ability in females with male co-twins, but it should be noted that this study has appeared as a meeting abstract only and it permits no confident conclusions as it offers no detailed information about the sample size and characteristics and assessment procedures.

To date, there are two studies of handedness in twins from opposite- and same-sex pairs (Elkadi, Nicholls, & Clode, 1999; Ooki, 2005). Both studies tested the GBG hypothesis and assumed that if females from opposite-sex pairs are exposed to elevated levels of testosterone prenatally then they should have higher prevalence of left-handedness compared to females from same-sex pairs. Elkadi et al. (1999) found no

difference between females from opposite- and same-sex pairs. Ooki (2005) reported lower prevalence of left-handedness in females from opposite-sex pairs compared to females from same-sex pairs, but that difference was not significant. Further, significantly lower prevalence of left-footedness in females with male co-twins compared to females with female co-twins was reported in this study.

### **1.3.2 Postnatal socialization as an alternative explanation for masculinization**

When studying female twins with male co-twins, it should be stressed that masculinization effects, if they exist, need not only be prenatal in origin, but can result also from postnatal socialization. Previously, it has been reported that girls with a twin brother had higher leadership skills than girls with a twin sister or twin boys (regardless of their co-twins sex) or singletons at age 11-12 in a study of 1874 twins and their 23 200 non-twin class-mates from the FinnTwin12 study (Pulkkinen, Vaalamo, Hietala, Kaprio, & Rose, 2003), which might indicate that the socialization in females with male co-twins is different than in females with female co-twins and in non-twin females. The masculinization in traits like mental rotation ability could result from practice effects, whereas for physiological traits like dental asymmetry and otoacoustic emissions the socialization explanation may not be reasonable.

Growing up with a twin brother must be different than growing with a twin sister. One possible different sex-typed socialization between females with male co-twins and females with female co-twins could be exposure to sex-typed toys and activities. A study of over 5500 preschool children showed that the presence of an older brother in boys and girls was related to more masculine and less feminine behavior as measured with toy preferences, sex-typed activities and characteristics; whereas the presence of an older sister had sex-specific effects: boys were no more feminine and no effect on masculinity; girls were less masculine but no effect on their femininity (Rust et al., 2000).

It is also possible that parents of opposite-sex twins could encourage girls and boys from these twin pairs into less sex-typed activities than girls and boys from same-sex pairs, but it could be also other way round: the differences between girls and boys could be emphasized by parents of opposite-sex twins. The parents of singletons do show

different socialization of boys and girls into sex-typed play (Lytton & Romney, 1991), but there are no studies of parents of twins.

If females from opposite-sex pairs are masculinized in sex-typed activities and toy preferences, that might influence their spatial abilities. There is good evidence that engagement in male typical activities like computer game playing are related to good spatial abilities (Feng et al., 2007), but sex-typical activities are not only reflecting socialization effects: for example females with CAH have been found to show increased preference for boys' toys and activities (Hines, 2006) and moreover fetal testosterone was found to be related to sex-typed play in 6-10 year old girls and boys from the general population (Auyeung et al., 2009). Thus it is possible that prenatal testosterone enhances engagement into male typical activities which in turn enhances male favored spatial abilities like mental rotation skills. However, one twin study did not support either postnatal or prenatal masculinization of sex-typed toy preferences: girls with a twin brother did not differ from girls with a twin sister in time spent with boys toys (Henderson & Berenbaum, 1997).

Hardly any psychological trait in humans could be attributed to mere nature or nurture as they are inextricably linked. Thus, making clear distinction on whether the masculinization in a given trait is a result of prenatal masculinization or postnatal socialization is not easy and should not be a sole aim of the studies comparing females with male co-twins and females with female co-twins. As it is not possible to conduct human studies where hormone levels are manipulated, human twin studies, often with large population-based samples, offer a valuable natural setting to study whether the prenatal masculinization hypothesis and occurrence of prenatal transfer of testosterone from male to female fetus can be extended to humans.

## 2 Aims of the study

The aims of this study were to investigate the origins of the sex differences in laterality and spatial ability, as represented by handedness and mental rotation ability, respectively. Twin data was utilized in two ways; 1) by conducting twin modeling to investigate genetic and environmental effects on handedness and mental rotation ability; 2) by comparing the differences in handedness and mental rotation ability between twins from the same-sex pairs and twins from the opposite-sex pairs. The latter aim was related to the controversial issue of possible prenatal transfer of testosterone in humans.

The specific aims were:

1. To study whether left-handedness is more common in males than in females in Finland.
2. To determine how much of the variance in handedness is explained by genetic and environmental effects, and to study whether there are singleton, twin, and triplet differences in handedness.
3. To test whether the prevalence of right-handedness is higher in females with male co-twins compared to that of females with female co-twins. To test whether there is difference in fluctuating levels of testosterone and estradiol between left- and right-handers and to test if there are differences in the levels of these hormones in twins from opposite- and same-sex pairs.
4. To test if male twins outperform female twins in Mental Rotation Test, and to test if females with male co-twins are masculinized in mental rotation ability.
5. To investigate if there are sex-specific genetic or environmental effect on mental rotation ability and to find out whether the same or different set of genes affect mental rotation performance in males and females.

## **3 Methods**

### **3.1 Participants**

All of the subjects in this thesis were individuals who have participated in the Finnish twin studies conducted in Department of Public Health, University of Helsinki. The studies included in this thesis utilized two population-based twin study cohorts, 1) the older Finnish Twin Cohort, which comprises of Finnish same-sex pairs born before 1958 (Kaprio & Koskenvuo, 2002), and 2) FinnTwin12, which includes Finnish twins, both from opposite- and same-sex pairs, born in 1983-1987 (Kaprio, Pulkkinen, & Rose, 2002). Both studies have identified the twins through Central Population Registry of Finland and have invited all twin pairs with both twins alive to participate. These ongoing longitudinal studies have reached very high participation rates: 89% and 92% at the first baseline data collection for older Finnish Twin Cohort and FinnTwin12, respectively.

#### **3.1.1 Older Finnish Twin Cohort**

Studies I and II comprised of all participants, who were under 70 years of age, from the Older Finnish Twin Cohort. The original inclusion criterion for twin pair selection was persons born in the same day, in the same municipality, and having a same surname. As a result of this selection procedure, the older Finnish Twin Cohort includes also singletons and triplets, who fulfilled the selection criterion. Study I comprised of 4068 singletons, 25810 twins from same-sex pairs, and 283 triplets.

The zygosity determination was based on the accurate questionnaire method (Sarna, Kaprio, Sistonen, & Koskenvuo, 1978). In addition, zygosity has been validated for selected pairs by using genetic markers. The older Finnish Twin Cohort study protocol has been approved by the national Board of Health of Finland.

### **3.1.2 FinnTwin12**

Studies III, IV, and V utilized FinnTwin12 (aka FT12) study. FT12 study design is based on two samples: 1) the epidemiological sample consists of five birth cohorts of twins, born in 1983-1987 and their parents, while 2) the intensive sample comprises of subset of twins drawn from the epidemiological sample. Two thirds of the intensive sample were selected at random from the epidemiological sample while about one third of the twins were selected on the basis of their parents elevated alcohol related problems as measured with self-reported Malmö-modified Michigan Alcoholism Screening Test (Kristenson & Trell, 1982; Seppa, Sillanaukee, & Koivula, 1990). The epidemiological sample was used in the study III, which comprised of 4736 twins at age 14. The fourth wave of data collection of the Intensive sample was utilized in studies IV and V, which comprised of 804 young adult twins at age 21-24 years.

The zygosity determination in FinnTwin12 was based on the validated questionnaire method (Sarna et al., 1978), with additional questions for younger twins (Goldsmith, 1991). The zygosity was determined from DNA for most of the twins in the intensive sample who participated in the fourth wave of data collection (Studies IV and V). The FinnTwin12 study protocol is approved by ethical committee of Helsinki and Uusimaa Hospital district, Finland, and by the IRB of Indiana University, Bloomington, USA. Parents have given consent to their twins participation at age 14 and twins completed written informed consent as adults before their participation to fourth wave of data collection.

## **3.2 Measures**

### **3.2.1 Handedness measures**

In Studies I and II, handedness was measured with two questions: 1) as a child, were you right-handed, left-handed or used your both hands equally; 2) at the moment, are you writing with right hand? No or Yes. In these studies, the information about possible forced right-handedness was obtained with the following question: if you were left-handed as a child, were you forced to write with right hand? No or Yes. In Studies I and



If the handedness analyses were conducted separately for both handedness measures, but also restricting analyses to those individuals who reported no inconsistency between handedness questions or no right-handed writing due to forced right-handedness (for a detailed information about exclusion criterion see Study I)

Also Study III assessed handedness with two questions: 1) are you: right-handed, left-handed or use both hands equally well; 2) do you write with your right hand? No or Yes. In this study, analyses were done mainly by including only individuals who reported themselves as consistent left- or right-handers.

### **3.2.2 Mental Rotation Test**

Mental rotation ability in Studies IV and V was measured with a redrawn version of Vandenberg and Kuse Mental Rotation Test (Peters et al., 1995) which, in turn, is based on stimulus materials of Shepard and Metzler (Shepard & Metzler, 1971). This paper and pencil administered MRT included a 5-minute practice in which subjects completed four trials. After completing the practice trials, all participants were given correct answers to those trials. The actual test, MRT-A, consisted of two parts, each with 12 trials. In each trial, there was one target figure and four figures where the target figure was presented as viewed from different angles. The participant's task was to mark the two figures that match the target figure by mentally rotating the figures through the vertical axis. There was a three minute time limit for each of the two parts. In order to reduce guessing, participants were given one point only if they had marked the two correct alternatives of each trial. Thus, the possible total score ranged from 0 to 24. MRT yielded also separate scores for each of the two parts (possible range from 0 to 12). Number of attempted trials and percentage of correct trials out of attempted trials were also recorded. MRT was administered individually or in groups of two to nine participants (size of the group had no effect on the MRT scores either in females or males, data not shown).

### **3.2.3 Hormonal measures**

Activational effects of testosterone and estradiol in Study III were studied from two saliva samples. Saliva samples were collected from a subsample of FT12 participants from the intensively studied twins including 771 participants from 1986 and 1987 cohorts. Testosterone and estradiol measures were adjusted for diurnal and seasonal effects, and log transformation was used to reduce skewness. Detailed information on saliva collection procedure, determination of hormones and correction of skewness can be found in Study II and in (Eriksson, Kaprio, Pulkkinen, & Rose, 2005).

### **3.2.4 Other measures**

Basic demographic variables included age, sex and zygosity. Twins from the same-sex pairs were either monozygotic (MZ) or dizygotic (DZ). Birth and pregnancy related variables in FinnTwin12 included Apgar scores, birth order, birth weight, gestational age, and mother's age at twin's birth. Apgar scores, birth weight and gestational age information were obtained from twins' parents as a part of a baseline family questionnaire. In Finland, Apgar scores, birth order, birth weight and gestational age information are recorded also on child-specific booklets by the maternity hospital and well-child clinic staff, which is a free pre-school health service provided to and used by virtually all parents. The booklets are kept by the mother. Mother's age at twin's birth was obtained through Central Population Registry. In the older Finnish Twin Cohort the birth order was asked from twins as a part of the questionnaire study.

Computer game playing experience was self-reported by the twins in a questionnaire completed before the administration of MRT. Participants indicated how often they play video or computer games: 1) less than once a month, 2) once a month, 3) once a week, 4) couple of times in week, 5) daily, less than two hours, 6) daily, more than two hours.

## 3.3 Statistical analyses

### 3.3.1 Modeling of genetic and environmental effects in twin data

One of the advantages of twin data is the possibility to estimate how much of the phenotypic variance in some trait is explained by genetic and environmental effects. The classical twin design of heritability estimation is based on the comparison of monozygotic (MZ) and dizygotic (DZ) twin pairs. MZ twins always have same-sex co-twin whereas DZ twins can have either opposite-sex or same-sex co-twin.

The purpose of the twin modeling is to estimate how much of the variance is explained by additive genetic effects (A), common environmental effects (C), and unique environmental effects (E). The A effects refer to effects that are caused by sum of many genes. The C effects refer to all environmental things that make twins alike and are often called shared environmental effects, while the E effects refer to all things that make twins unlike from each other. The error of measurement is also included in the E component. Also dominant genetic effects (D) can be estimated, but not simultaneously with C effects: therefore the model is either ACE or ADE (note: the C and D components can be included in the same model if twin data has information also on siblings of twins). The estimates for genetic and environmental effects are obtained by decomposing the phenotypic variance into additive genetic, dominant genetic, common environmental, and unique environmental variances.

The estimation of A, C, D, and E components is based on the assumption that MZ twins share all of their genes and thus have identical genotype, whereas DZ twins share on average half of their genes and their genotypic resemblance is equivalent to siblings who are not twins. Since MZ twin share their genes, the correlations of A and D effects are 1.0 in MZ twins, whereas in DZ twins the correlation is 0.5 and 0.25, for A and D effects, respectively. For the C effects the correlation is 1.0 for both MZ and DZ twins. The E effects are unique to each member of the twin pair, thus they do not correlate between co-twins. For a illustration of univariate ACE model see Figure 1.

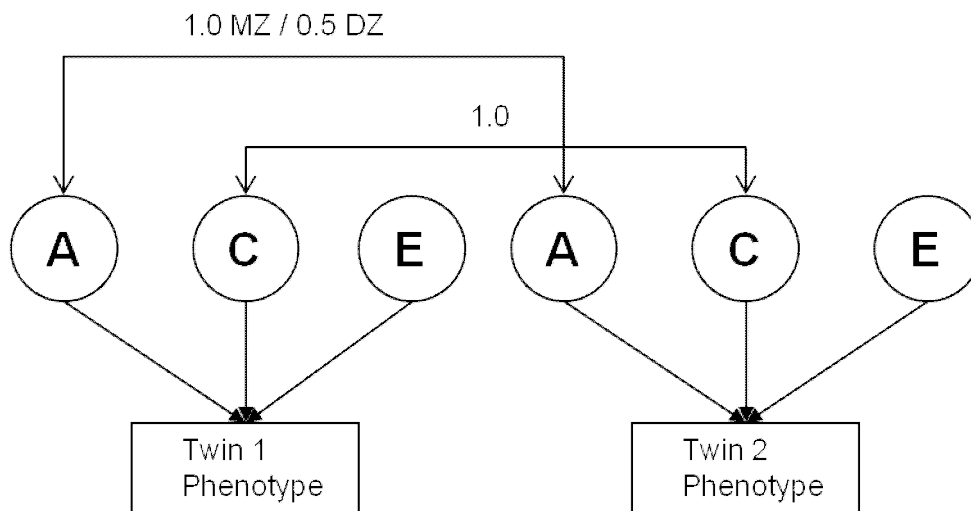

**Figure 1.** Univariate model with additive genetic (A), common environmental (C), and unique environmental (E) effects. A effects correlate 1.0 in monozygotic (MZ) and 0.5 in dizygotic (DZ) twins. For C effects the correlation is 1.0 for both MZ and DZ twins.

Higher MZ than DZ pairwise correlation is indicative of genetic effects. Preliminary decision on whether to start with ACE or ADE model can be assessed from pairwise correlations in MZ and DZ twins. If the MZ within pair correlation is more than two times the DZ within pair correlation, then dominant genetic effects are suggested and ADE model might fit the data better than ACE model.

The initial phase in structural equation modeling is to test whether there are differences in means and variances between MZ and DZ twins. The basic assumption in twin modeling is that the means and variances do not differ between MZ and DZ. If such differences (violation of twin modeling assumption) exist, they have to be taken into account in the modeling. The difference in means and variances are tested in the saturated ACE (or ADE) model, which allows the free varying of the parameters. After getting the fit statistics from the saturated model, the full ACE (or ADE) model, where MZ and DZ means and variances are set to be equal, is compared against the saturated model. If the fit of the full ACE (or ADE) model is not significantly poorer than the fit of the saturated model, then the assumptions of twin modeling are not violated and several sub models can be tested against the full ACE (or ADE) model. Also sex effects on means and variances can be tested in the saturated model.

After obtaining estimates for genetic and environmental components in the full ACE (or ADE) model, the next step is to drop one component of the model at a time. In order

to decide which model has the best fit of the data, the sub-models are tested against full ACE (or ADE) model by comparing the change of the chi-square statistics and taking into account the change in the degrees of freedom. The other commonly used fit statistics is Akaike's Information Criterion (AIC). If the fit of the models is equal, then the most parsimonious model is preferred. The sub models tested against the full model are AE, CE, and E. The E component cannot be dropped since it includes also the error of measurement. If the *p*-value of the change in chi-square statistics is less than 0.05, then the dropping of component worsens the fit and sub model cannot be accepted.

If the saturated model has indicated significant sex effects on means and/or variances then sex-limitation model is preferred. In the sex-limitation model it is possible to test whether the A, C (or D) and E components can be fixed to be equal in females and males. If the data includes also twins from opposite-sex pairs, it is possible to test also whether the same or different set of genes is operating in females and males. For a more detailed description of sex-limitation model see Study V.

The modeling of genetic and environmental effects was conducted with Mx-program (Neale, Boker, Xie, & Maes, 2003), which is specifically designed for analyzing twin and family data. Maximum likelihood method was used to get estimates of additive genetic, common environmental, and unique environmental effects in handedness and in MRT.

### **3.3.2 Other statistical analyses**

The differences in the prevalence of left-/right-handedness in studies I, II, and III were analyzed with chi-square tests. In study V, chi-square statistics were used to test the sex difference in the proportion of top and bottom scores in MRT. The differences in MRT (study IV) and hormonal levels (study III) between different twin groups as well as differences in birth and pregnancy related variable between left- and right-handers (study III) were analyzed by using adjusted Wald test. Also regression analysis (study IV) and logistic regression analysis (study III) were used in the comparisons whenever covariates were included in the analysis. In all analyses, whenever twins were included, the clustered data (twins nested in families) was taken into account in order to get robust estimates for standard errors in Wald tests and for confidence intervals of odds ratios

(Williams, 2000). Thus the design-based F-values were used (Rao & Scott, 1984) and the number of degrees of freedom refer to number of clusters (families), not individuals, in these analyses.

Pairwise correlation coefficients were calculated in study V. Standard error for variance ratio in study V was obtained with bootstrap method by taking the clustered data into account.

All analyses, other than genetic modeling, were done with SPSS (2008) and Stata (2006) statistical packages. The probability level of  $p < .05$  was considered as an indicator of statistically significant result.

## 4 Results

### 4.1 Sex differences in left-handedness

There was a significant sex difference in handedness: left-handedness was more common in males than in females (Study I, II and III). Among 30161 adults from the older Finnish Twin Cohort study 8.7% of males and 6.8% of females reported that they were left-handed as a child. Further, 6.7% of males and 5% of females reported that they were left-handed writers in adulthood. Since there was a significant difference in the prevalence of left-handedness between singletons and multiples in Study I, the sex difference in left-handedness was also analyzed separately for 4068 singletons (Study II). The results from Study II showed that males are more often left-handed also among singletons.

In addition to singletons, the sex difference in left-handedness was also evident in twins as indicated by studies I and III. The Mantel-Haenszel combined male to female odds ratio from the participants of the older Finnish Twin Cohort and FT12 was 1.28 (95% CI 1.15, 1.41). Mantel-Haenszel test of homogeneity indicated no heterogeneity between these two samples ( $\chi^2(1) = 2.56, p = .11$ ). The sex ratio was similar, although the prevalence of left-handedness was lower in the older Finnish Twin Cohort (4.9%) than in the FT12 (9.1%).

The sex difference in childhood left-handedness and adult writing hand remained in different age groups (from 18 till 69 years), with the exception of more left-handed writers in female singletons among 60-69 years olds (Study II). Studies I and II included only individuals who were under 70 years old, but the original data had information also on 724 participants aged 70-95. As in younger cohorts, the self-reported childhood left-handedness was more common among males (3.6%) than in females (2.8%), and similarly adult left-handed writing was more common in males (5.4%) than in females (3.8%), although these differences were not statistically significant.

Finally, the sex difference in left-handedness remained also after exclusion of left-handed individuals who were forced to use their right-hand and individuals who reported inconsistency between childhood and adult handedness (Study II).

## 4.2 Genetic and environmental effects on handedness

Twin modeling indicated that the genetic effects in childhood handedness are very small or non-existent. Depending on the model, additive genetic effects explained 0-8% of the variance in handedness and the 95% CI's included 0 in every model. The remaining variance was explained by unique environmental effects in these models. The genetic effects were more evident when adult writing-hand was analyzed. In the best fitted model (AIC = -4.23) where forced-handedness was not taken into account, the additive genetic effects explained 21% (95% CIs 11 – 30%) of the variance, while rest of the variance was explained by unique environmental effects.

When forced-handedness as well as inconsistency between childhood and adult handedness were taken into account, the genetic effect explained 26% (95% CIs 16 – 37%) of the variance in handedness in the best fitted model (AIC = -2.42) with remaining variance accounted by unique environmental effects. Besides the AE model, the CE model also fitted the adult writing hand data; common environmental effects explained 14% (95% CIs 7 – 21%) of the variance in the model where forced-handedness and inconsistent handedness were not controlled (AIC = -2.48) and 18% (95% CIs 10 – 26%) of variance in the model where forced-handedness and inconsistent handedness were controlled (AIC = -0.21).

## 4.3 Prevalence of left- and right-handedness in twins from opposite- and same-sex pairs

The prevalence of right-handedness was significantly (OR 1.29, 95% CI 1.07 – 1.56,  $p < .01$ ) higher in females with male co-twins (94.7%) compared to females with female co-twins (91.4%). Further that difference remained after controlling for gestational age and birth weight (these two covariates were entered in the model because there was a trend for a differences in these variables between right- and left-handed individuals) in the logistic regression model (OR 1.22, 95% CI 1.01 – 1.48,  $p < .05$ ). Among males, the sex of a co-twin was not related to handedness (Study III).



#### **4.4 Activational levels of sex hormones and handedness**

The activational levels of estradiol and testosterone did not differ between left- and right-handed subjects (Study III). An additional analysis was conducted to test whether there are differences in activational levels of these sex hormones between left- and right-handed individuals within handedness discordant MZ pairs. Among 16 such pairs of females, testosterone levels were higher in left-handed than in right-handed individuals, but that difference was far from significant ( $p = 0.86$ ). Among nine pairs of male MZ pairs discordant for handedness, left-handed individuals had higher testosterone levels than right-handers, but that difference was not statistically significant ( $p = .089$ ). Twenty one pairs would be needed to achieve power of .80 to detect such a difference.

Males had significantly higher testosterone levels, whereas females had significantly higher estradiol levels. There were no significant difference in estradiol and testosterone levels between females with male co-twins and females with female co-twins or between males with female co-twins and males with male co-twins (Study III).

Neither hormone levels nor handedness differed between twins who were selected on the basis of their parents elevated alcohol related problems and twins who were selected at random from the epidemiological sample (Study III).

#### **4.5 Pregnancy and birth related variables and handedness**

Apgar scores, birth weight, gestational age and mother's age at twin's birth were not related to handedness (Study III). Also the prevalence of left-handedness was equally common in first and second born twins both in FT12 (Study III) and in the older Finnish Twin Cohort (Study I).

Multiple pregnancies appeared to increase the probability of left-handedness. The prevalences of self-reported childhood left-handedness and left-handed writers in the older Finnish Twin Cohort were significantly higher in twins and triplets than in singletons, and the prevalence of self-reported childhood ambidextrousness was significantly higher in triplets than in singletons and twins (see Table 1 in Study I).

## 4.6 Sex difference in the mental rotation test

Males outperformed females in MRT when total score was used and this sex difference was evident also among individuals from same-sex pairs as well as among individuals from opposite-sex pairs (Study IV and V). This sex difference was evident also in the means for first and second parts separately. Moreover, the percentage of correctly answered trials (i.e. both right answers for given trial) out of attempted trials was significantly higher in males than in females. Males also attempted significantly more trials than females (Table 2).

The sex difference in the total score of MRT remained after adjusting for age, birth weight, gestational age, mothers age at twins' birth, and computer game experience (Study IV).

Males had also significantly greater variance in their MRT performance (variance ratio 1.34, 95% CI's 1.13, 1.61). Males' higher mean score was reflected in the tail regions of MRT scores: 84% of the best 10% scorers were males, whereas only 21% of the poorest 10% scorers were males.

**Table 2.** Mental rotation test performance in female and males from same-sex pairs (means and 95% CI's in parentheses).

MRT measure	SSF	SSM	<i>p</i> <
Total score	9.01 (8.50 – 9.53)	12.9 (12.2 – 13.6)	.001
Part I Score	4.81 (4.50 – 5.12)	6.83 (6.41 – 7.24)	.001
Part II Score	4.20 (3.94 – 4.46)	6.03 (5.67 – 6.39)	.001
Attempted trials	14.7 (14.2 – 15.2)	17.6 (16.9 – 18.3)	.001
Percentage of correct trials out of attempted trials	61.3 (58.6 – 64.0)	73.1 (70.4 – 75.8)	.001

SSF = female twins with female co-twins, SSM = male twins with male co-twins.

There was no difference in the Mental Rotation Test performance between twins who were selected on the basis of their parents elevated alcohol related problems ( $M = 10.91$ ,

$SD = 4.72$ ) and twins who were selected at random from the epidemiological sample ( $M = 10.91$ ,  $SD = 4.92$ ).

#### **4.7 Genetic and environmental effects on mental rotation test**

The saturated model indicated that there were significant sex effects on the means, variances and covariances of MRT data. There were no significant zygosity effects on the means, variances and covariances. Full ACE or full ADE sex-limitation models did not worsen the fit when compared against the saturated model, thus several sub-models could be tested against full ACE and full ADE models.

The full ACE model, where different magnitude for genetic and environmental effects were allowed for males and females yielded following estimates:  $A = 50\%$ ,  $C = 5\%$ ,  $E = 45\%$  for females and  $A = 40\%$ ,  $C = 10\%$ ,  $E = 50\%$  for males. The full ADE model, where different magnitude for genetic and environmental effects were allowed for males and females yielded zero estimates for D effects both in males' and in females' estimates. The AE model fitted data significantly better than either full ACE or ADE model.

Twin modeling indicated that the best fitting model to MRT data was sex-limitation AE model where different parameter estimates were allowed for males and females ( $AIC = -3.72$ ). The relative proportion of the variance explained by A and E effects were almost same in males,  $A = 53\%$  (95% CIs 33 – 68%), and females,  $A = 55\%$  (95% CIs 42 – 67%), but the absolute variances for A and E effect were higher for males than for females (Study IV). The model where opposite-sex pairwise correlation was fixed to 0.5 fitted data well, indicating that same set of genes are operating in males and females in MRT performance (Study V).

#### **4.8 Mental rotation performance in twins from opposite- and same-sex pairs**

Females with male co-twins performed significantly better than females with female co-twins in MRT. The difference was evident in the total score (Study IV), but also when

parts I and II were considered separately. OSF twins also attempted more trials than SSF twins, and further OSF twins completed significantly more trials successfully than SSF twins (Table 3).

**Table 3.** Mental rotation test performance in female twins with opposite- and same-sex co-twins (means with 95% CI's in parentheses).

MRT measure	SSF	OSF	<i>p</i>
Total score	9.01 (8.50 – 9.53)	10.3 (9.5 – 11.0)	.007
Part I Score	4.81 (4.50 – 5.12)	5.54 (5.10 – 5.98)	.008
Part II Score	4.20 (3.94 – 4.46)	4.76 (4.35 – 5.17)	.024
Attempted trials	14.7 (14.2 – 15.2)	15.7 (14.9 – 16.5)	.044
Percentage of correct trials out of attempted trials	61.3 (58.6 – 64.0)	66.1 (62.6 – 69.5)	.033

SSF = female twins with female co-twins. OSF = female twins with male co-twins.

The differences between OSF and SSF twins remained after controlling for pregnancy and birth related variables, and computer game experience. Among males, there was no significant difference between males with female co-twins and males with male co-twins (see Fig. 1 in Study IV).

#### **4.9 Computer game playing experience and mental rotation test performance**

Males reported significantly more computer game playing than females ( $F = 19.91, p < .001$ ). Among females, there was no significant difference in the self-reported computer game experience between females with male co-twins and females with female co-twins ( $F = 1.49, p = .19$ ). Similarly, there was no significant difference between males with female co-twins and males with male co-twins ( $F = 1.21, p = .30$ ). The prevalences of computer game playing experience by twin groups are displayed in Table 4.

When computer game playing frequency was categorized as less than daily vs. daily 28% of males reported playing daily, whereas only 11% of females reported daily computer game playing. Both male and female twins from opposite-sex pairs reported more often daily playing of computer games than twins from same-sex pairs, but these differences were not statistically significant (with p values of .25 and .11 in males and females, respectively).

**Table 4.** Prevalence of computer game experience in male and female twins from opposite- and same-sex twin pairs (number of subjects in parentheses).

	Computer game playing experience						total n
	less than once a month	once a month	once a week	couple of times in week	daily, less than 2 hours	daily, more than 2 hours	
SSM	35% (77)	14% (30)	10% (21)	16% (35)	12% (26)	14% (30)	219
OSM	24% (26)	14% (15)	15% (16)	16% (18)	18% (19)	15% (16)	110
SSF	68% (237)	11% (40)	5% (19)	5% (19)	6% (20)	4% (13)	348
OSF	61% (73)	8% (10)	8% (10)	8% (9)	12% (14)	3% (4)	120

SSM = male twins from same-sex pairs, OSM = male twins from opposite-sex pairs, SSF = female twins from same-sex pairs, OSF = female twins from opposite-sex pairs.

Computer game playing experience had negligible association with MRT performance. Males who reported playing computer games a couple of times in week outperformed those who reported playing less than once a month ( $B=2.03$ ,  $p=.02$ ), and females who reported playing once a month outperformed those who reported playing less than once a month ( $B=2.13$ ,  $p=.002$ ). Mean MRT score in different twin groups by computer game playing experience can be seen in the Figure 2.

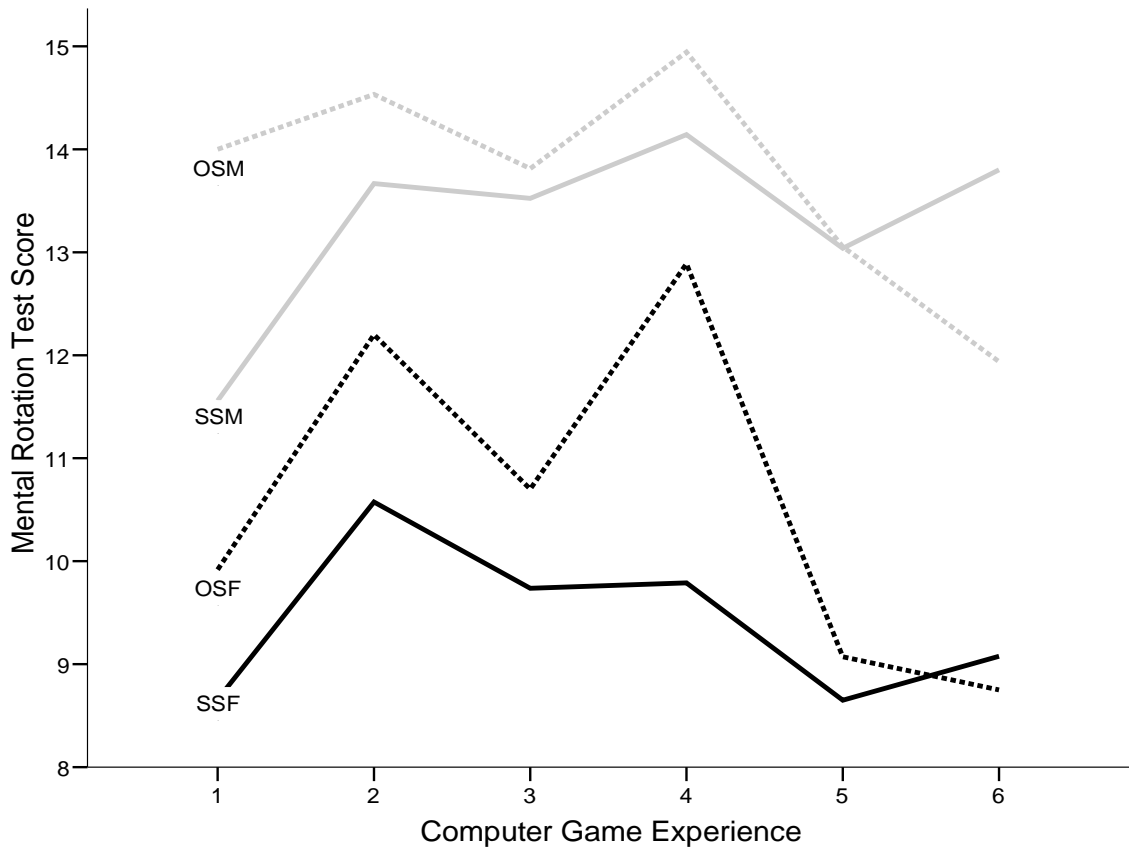

**Figure 2.** Mental Rotation Test (MRT) performance in different twin groups by computer game experience. Computer game experience categories were: 1) less than once a month, 2) once a month, 3) once a week, 4) couple of times in week, 5) daily, less than two hours, 6) daily, more than two hours. SSF = female twins from same-sex pairs, OSF = female twins from opposite-sex pairs, SSM = male twins from same-sex pairs, OSM = male twins from opposite-sex pairs. The number of participants for each group by twin type are displayed in Table 4 above).

#### 4.10 Pregnancy and birth related variables and mental rotation performance

Birth weight and mothers age at twins' birth were not related to MRT performance. Gestational age was related to MRT performance in females. The correlation between MRT performance and gestational age in all females was .14 ( $p < .01$ ), and .12 ( $p < .05$ ) in females from same-sex pairs, and .20 ( $p < .05$ ) in females from opposite-sex pairs (Figure 3).

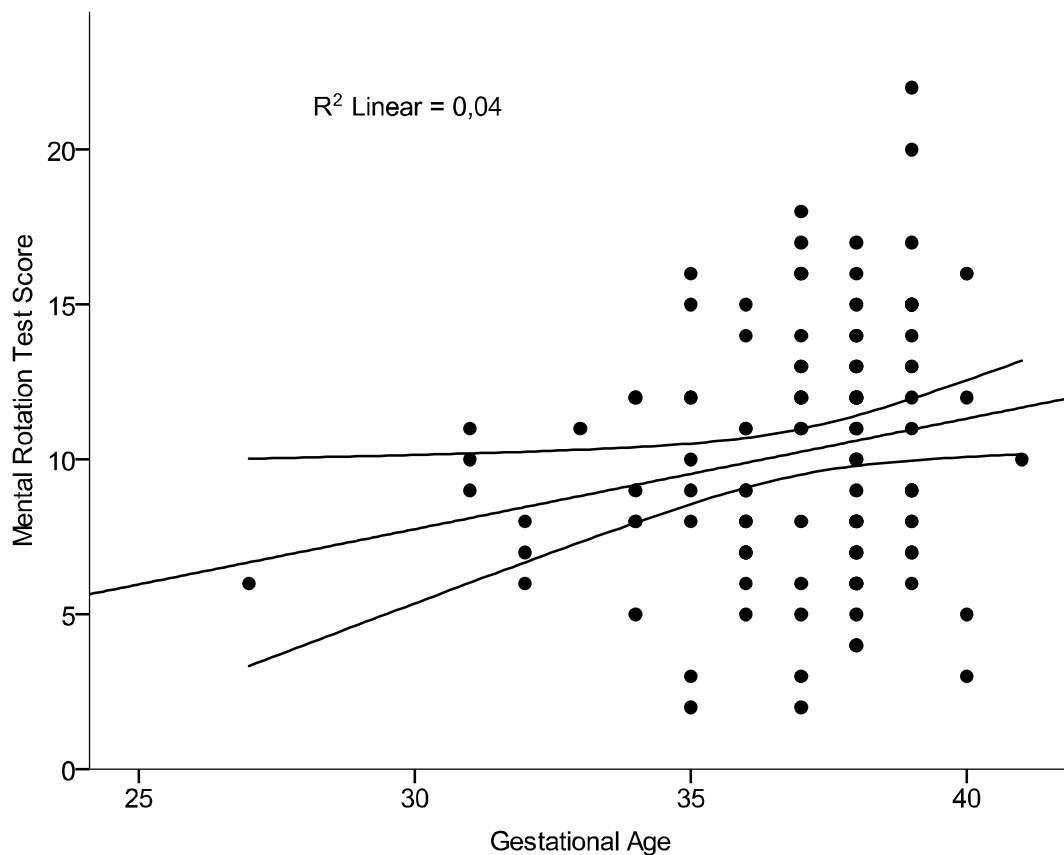

**Figure 3.** Scatterplot of Mental Rotation Test performance and gestational age (in weeks) in females with male co-twins. Linear regression line with 95% CI's.

#### **4.11 Additional evidence to support the prenatal origin of masculinization of mental rotation performance in females with male co-twins**

Based on the results from Studies III and IV an additional analysis in this thesis summary was performed to further investigate whether the observed masculinization of females with male co-twins is prenatal or postnatal in origin. Study III indicated that OSF twins have significantly higher prevalence of right-handedness compared to SSF twins. Even if this would be a result of prenatal transfer of testosterone, the right-handedness itself could not be considered as a marker of exposure to elevated levels of prenatal testosterone in females, because majority of humans, approximately 90%, are right-handed. But assuming that the higher prevalence of right-handedness of OSF

twins compared to SSF twins is due to OSF twins' exposure to elevated levels of prenatal levels of testosterone, one might think that OSF twins who are left-handed are likely those who are not exposed to elevated levels of prenatal exposure. This hypothetical inference was placed on test by investigating the MRT performance of females with male co-twins according to their handedness. In Study IV it was found that females with male co-twins were masculinized in their MRT performance, but whether this was a result of prenatal effects of testosterone transfer or postnatal socialization could not be solved. Thus, this additional analysis asked whether the masculinization of OSF twins is evident both in left- and right-handers? If left-handed OSF twins are those who do not show signs of elevated prenatal testosterone transfer, then it could be assumed that their MRT performance is not masculinized. As indicated by Study III; for males, the handedness is not expected to play role as a marker of elevated prenatal testosterone levels. Thus, the specific question of this additional analysis was:

1. Are only right-handed females with male co-twins masculinized in their MRT performance?

In conjunction with MRT testing, twins indicated their writing hand as; 1) always left; 2) usually left; 3) either hand; 4) usually right; 5) always right. Always and usually responses were combined and one individual who indicated both hands to equally good in writing was omitted from the analysis.

Results of this analysis showed that only right-handed OSF twins performed significantly better than SSF twins in MRT. In contrast, the MRT performance of left-handed OSF twins was poorer than that of SSF twins, although that difference was not significant. Further, among OSF twins, 114 right-handed individuals ( $M = 10.41$ ,  $SD = 4.12$ ) performed significantly better than 6 left-handed individuals ( $M = 7.33$ ,  $SD = 1.75$ ) in MRT ( $t = 3.79$ ,  $p < .01$ ). Besides the OSF twin group, there were no significant differences in MRT performance between left- and right-handed individuals among SSF, SSM, and OSM groups (Figure 4).



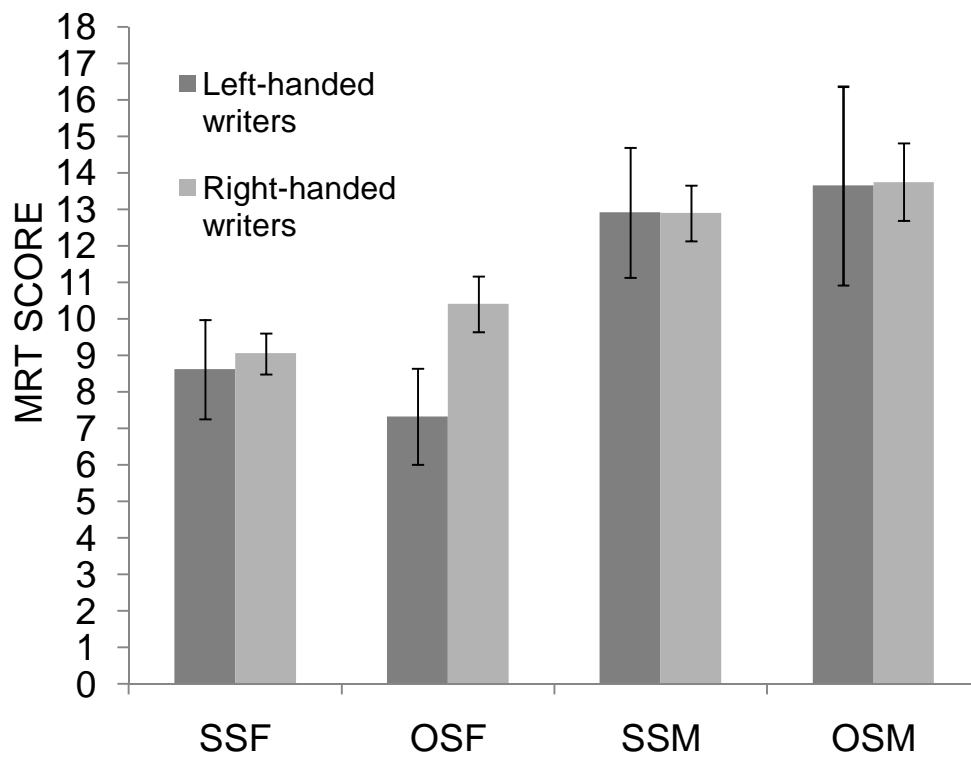

**Figure 4.** Mean score on Mental Rotation Test (MRT) in different twin groups by handedness. SSF = female twins from same-sex pairs, OSF = female twins from opposite-sex pairs, SSM = male twins from same-sex pairs, OSM = male twins from opposite-sex pairs. Error bars represent 95% confidence intervals.

## 5 Discussion

### 5.1 Sex differences in handedness and mental rotation performance

The sex differences in handedness and mental rotation ability among twins in this study were similar and of same magnitude as reported earlier in singletons (Papadatou-Pastou et al., 2008; Sommer et al., 2008; Voyer et al., 1995); left-handedness was more common in males and males outperformed females in mental rotation performance.

Although the sex difference in the prevalence of left-handedness is one of the best replicated findings within psychological sex differences, a meta-analysis by Papadatou-Pastou et al. (2008) reported that the sex differences in left-handedness are not evident in Finland and Scandinavian countries. The present results clearly shows that this statement is not true: males are more likely than females to be left-handed also in Finland and Scandinavian countries when studied in large population based samples. In contrast, the inference of no sex differences in left-handedness in Finland and Scandinavian countries (Papadatou-Pastou et al., 2008) was based on small and selected data sets; that inference is contradicted by population-based, representative samples.

The sex differences in left-handedness and mental rotation ability were evident when the comparisons were made between females and males from same-sex pairs, but also when comparisons were made between females and males from opposite-sex twin pairs. This indicates that these cognition related sex differences remain in females and males who have shared family environment and who share, on average, half of their genes. In singletons, parents encourage boys and girls differently into sex-typed activities (for a meta-analysis, see Lytton & Romney, 1991), but whether this different socialization of boys and girls is also evident among parents of opposite-sex twin pairs has not been studied. Sex-typed socialization could result in the well known sex difference in mental rotation ability, and that might be one explanation of why sex difference in mental rotation ability exist also between females and males from opposite-sex twin pairs.

Stereotype threat theory (Steele, 1997; Wraga et al., 2007) could explain the reported sex difference in MRT between females and males from same-sex pairs, and also the fact that sex difference remained between females and males from opposite-sex pairs.

There was no information on participants' attitudes on their spatial abilities in the present study, thus it is not possible to decide whether anxiety before and during testing had any effect on MRT performance. The anxiety related to test taking situation might be different if the MRT is administered individually or in a group. The present study indicated that the sex difference in MRT was evident both when the MRT was administered individually or as a group testing and the size of the group had no effect on the sex difference. While it is not possible to know whether the size of the testing group is related to anxiety during spatial testing, this result indicates at least that the sex difference in MRT performance is not dependent on the presence of other people.

## **5.2 Genetic and environmental effects on handedness and mental rotation ability**

The results indicate that the relative proportion of variance explained by genetic effects in handedness and mental rotation ability does not differ between sexes. However, in relation to handedness, it should be noted that the present sample was probably not large enough to test the sex-specific genetic effects due to small number of left-handed concordant pairs. Since left-handed concordant twin pairs are very rare, the current data could not definitely distinguish whether the familial effects are due to additive genetic or common environmental effects.

In adult writing hand, about one quarter of the variance in handedness was explained by additive genetic effects, which is in line with a large twin study of handedness in Australian and Dutch samples, where additive genetic effects also accounted for about one quarter of the variance (Medland et al., 2009). Further, a meta-analysis of 35 twin samples have yielded a similar estimate for additive genetic effects (Medland et al., 2006). These results suggest that very large samples are needed to detect relative small genetic effects in handedness. That is why some earlier twin studies have not detected any genetic effects on handedness. The present results implicate that very large samples are needed to conduct genetic mapping studies of handedness as measured with direction. The present study showed that taking forced right-handedness into account increased the proportion of the variance explained by additive genetic effects, thus the

forced right-handedness should not be neglected when conducting studies with cohorts born in the first half of the 20<sup>th</sup> century.

In childhood handedness, depending in the model, 92-100% of the variance was explained by unique environmental effects. This indicates that this is a poor phenotype for molecular genetic studies on handedness. Individuals might answer the question regarding childhood handedness in different ways: some may report their handedness based on the view of their handedness before they had learned to write while others might have answered on the basis of their writing hand in childhood. Handedness establishes approximately at three to six years of age (De Agostini, Pre, Goudot, & Dellatolas, 1992; Bryden, Pryde, & Roy, 2000); this is probably one reason why genetic effects were so low in the models for childhood handedness.

In Mental Rotation Test, additive genetic effects explained about half of the variance in this study. When considering specific cognitive abilities, the genetic effects vary depending on the ability and how it is measured. Heritability varies also by population and age. For example, one study of middle aged males indicated no genetic effects in Wisconsin Card Sorting task (Kremen, Eisen, Tsuang, & Lyons, 2007), while genetic effects explained about 60% of the variance in Symbol Digit in the old age (Read et al., 2006). In general, specific cognitive abilities have smaller heritability than general cognitive ability, where about 50-70% of the variance is explained by genetic effects in young adults (Haworth et al., 2009; Lyons et al., 2009).

The heritability of mental rotation ability in the present study was almost comparable to heritability of general cognitive ability in young adults. This is in line with the Hawaii Family Study of cognition, where spatial abilities had highest familial resemblance (along with verbal abilities) compared to perceptual speed and memory (DeFries et al., 1979). The fact that about half of the variance in MRT is explained by genetic effects makes it useful as a phenotype for finding the genes for mental rotation ability. The genetic modeling results showed that same set of genes do operate in females and males, which suggests that females and males can be pooled for genetic mapping studies. This result does not support the view that spatial abilities are linked to X chromosome as suggested by some researchers (Blatter, 1982; Walker et al., 1981) and is in line with earlier studies (Bouchard & McGee, 1977; Corley, DeFries, Kuse, & Vandenberg, 1980; DeFries et al., 1979).

Although the magnitude of the relative genetic variance was similar in females and males, the absolute genetic and unique environmental variances were greater in males. This was due to males greater phenotypic variance in the MRT performance. Stereotype threat theory and different socialization of sexes can explain the sex differences in the mean performance in MRT, but whether they could also have an effect on the variability in the MRT performance is not clear. Based on the present study, it cannot be concluded why the phenotypic as well as the absolute genetic and unique environmental variances were larger in males.

### **5.3 Prenatal testosterone effects on handedness and mental rotation ability – or are the results explained by postnatal effects?**

The present study found significantly better mental rotation test performance and significantly higher prevalence of right-handedness in females with male co-twins compared to females with female co-twins. These findings are in line with hypotheses that link prenatal exposure to elevated levels of testosterone in females to enhanced spatial abilities (in male favoring tasks) and to right-handedness. Both of these findings in females from opposite-sex pairs can potentially be explained as a result of sharing the uterine environment with male fetus and thus being exposed to elevated levels of testosterone prenatally. While these findings strongly suggest that female twins from opposite-sex pairs are exposed to elevated levels of prenatal testosterone, the lack of the direct measure of prenatal testosterone in this study makes it impossible to draw definitive conclusions. The result considering mental rotation performance can be interpreted as an evidence of masculinization (either due to prenatal or postnatal effects) because the mean performance of females with male co-twins approached the mean performance of males. The result considering handedness was not masculinization in the same sense, because the increase in the prevalence of right-handedness was not in the direction of males, i.e. left-handedness is more common in males.

Many earlier studies of possible masculinization of females with male co-twins have not found any difference between females from opposite- and same-sex pairs and many positive findings of masculinization have not been replicated (e.g. Medland et al.,

2008a; Raevuori et al., 2008). One reason for earlier negative and non replicable findings might be that many studied phenotypes are traits that do not have known relationship to testosterone. When studying masculinization and possible effects of prenatal testosterone there should be strong evidence that the studied phenotype is linked to testosterone in general. For example, there is no good evidence that personality is related to testosterone levels; so why would females with male co-twins have masculinized personality due to prenatal exposure to testosterone if development of personality is not sensitive to testosterone in females? In this light it is not surprising that two studies have not found any difference in personality between females with male co-twins and females with female co-twins (Loehlin & Martin, 2000; Rose et al., 2002). Of course if masculinization is expected to results from socialization rather than from prenatal testosterone exposure, then it could be hypothesized that females with male co-twins might be masculinized also in traits that are not related to testosterone levels, such as personality.

Another reason why results of the present study are in contrast to earlier negative findings of masculinization could be that prenatal testosterone effects are probably time and tissue specific. For example the formation of 2D:4D ratio occurs probably earlier than the development of brain areas that are related to mental rotation ability. The possible influence of testosterone on mental rotation ability and handedness is likely affecting the brain functioning in some way, while the effects of testosterone on the formation of fingers is related to bone and soft tissue development. These effects are probably functioning through genes, and while gene expression is tissue specific, the effects of testosterone do not have to correspond exactly between brain functions and physical characteristics.

Testosterone levels are elevated from 8 to 24 gestational weeks (with peak levels from 12 to 18 weeks in amniotic fluid) in male fetuses, so if prenatal transfer of testosterone occurs in human twins then the exposure to testosterone in female members from opposite-sex pairs would happen during this time window. Consequently, the testosterone sensitive phenotypes that could be masculinized due to elevated prenatal testosterone exposure should be those traits that develop during 8 to 24 gestational weeks and preferably within 12 to 18 weeks, when the testosterone levels are at highest. When the formation of handedness and development of spatial abilities occurs is not

exactly known, but in girls, both of these traits as measured postnatally at ages 7 and 10 have found to be positively related to prenatal testosterone as measured from second trimester amniotic fluid (Grimshaw et al., 1995a ; Grimshaw et al., 1995b).

The better mental rotation performance in females with male co-twins compared to females with female co-twins could be also a result of postnatal socialization. Boys and girls prefer different sex-typed toys (see e.g. Hines, 2003) and some of the boys toys and activities that are more common in boys than in girls are related to spatial abilities. Computer game playing experience, as well as spatial play experience has found to be positively correlated with some spatial abilities (Baenninger & Newcombe, 1989; Feng et al., 2007) and further some studies have indicated that the spatial training and computer game experience are related to spatial abilities especially in girls (Quaiser-Pohl & Lehmann, 2002). Growing up with an age matched brother must be different than growing with twin sister. Females with male co-twins might have been exposed to male typical activities and play which have improved their spatial skills. In singletons it has been found that having a older brother relates to more masculine toy preferences and sex-typed activities, whereas having a older sister makes girls less masculine in these domains (Rust et al., 2000). It would be of great interest to see whether having a older brother or sister has any effect on mental rotation test performance.

In the present study, computer game experience had negligible association to mental rotation performance and the difference between females with male co-twins and females with female co-twins remained after controlling for computer game experience, which suggests that the masculinization effect is not explained only by greater exposure to male typical activity in females with male co-twins. Females with male co-twins had higher mental rotation test scores than females with female co-twins in individuals who reported playing computer games less than daily. However, of interest, the mean performance was almost at the same level among individuals who reported playing daily less than two hours and moreover among individuals who reported playing more than two hours daily, females with male co-twins had even lower mean score than females with female co-twins. But it should be noted that there were only three females with male co-twins who reported playing more than two hours a day. Because of the small number of subjects in this group and due to lack of a priori hypothesis of poorer mental rotation performance in those who play most computer games, this is most likely

due to chance. Here, males reported more computer game playing than females, but among females there was no difference between females with male co-twins and females with female co-twins indicating that females with male co-twins are not masculinized with regard to computer game playing. In line with that, earlier one study found no difference between girls with a twin brother and girls with a twin sister in sex-typed play (Henderson & Berenbaum, 1997).

But there are also other socialization related traits for which there were no information and the measure for computer game experience in the present study was crude and did not differentiate between action and non-action computer games; earlier it has been reported that practice in action computer games, but not in non-action games, enhances the mental rotation test performance (Feng et al., 2007).

Parents do encourage their sons and daughters for different sex typed activities (Lytton & Romney, 1991). It could be possible that parents of opposite-sex twins do not exhibit this different socialization of boys and girls with regard to sex-typed activities, but it is totally possible that different socialization of boys and girls into sex-typed activities could be also emphasized in parents of opposite-sex twins. Unfortunately, to date no such studies of parents of opposite-sex twins exists. It should be noted, that in the present study the effect size ( $d = .74$ ) for the sex differences in the mental rotation performance in males and females among opposite-sex pairs was comparable to effect size ( $d = .87$ ) between males and females from the same-sex pairs. If there were no different socialization of boys and girls among parents of opposite-sex twins, then it could be expected to results in smaller sex difference in the mental rotation ability (assuming that sex-typed activities are related to mental rotation ability) among males and females from opposite-sex pairs.

While stereotype threat theory (Steele, 1997) can adequately explain the sex difference between females and males both from opposite- and same-sex pairs, it is unlikely that such a theory could explain the seen masculinization of females with male co-twins. The prenatal masculinization hypothesis is not widely known and it was not presented for the participants of the present study. It is unlikely that females with male co-twins would consider themselves as more masculine than females with female co-twins. In support for this view, a study of another Finnish twin cohort indicated that females with male co-twins did not differ from females with female co-twins in self-



reported femininity-masculinity as measured with the Minnesota Multiphasic Personality Inventory (Rose et al., 2002). Similarly, the female participants of the present study estimated their own intelligence at same level regardless of their co-twins sex (Vuoksima et al., 2009).

The present study could not exclude the postnatal explanation for the higher prevalence of right-handedness in females with male co-twins, but it is much harder to come up with postnatal cause for the results concerning handedness than for the results for mental rotation ability. It is hard to think that parents would encourage their daughters differently regarding left/right hand use if the daughter has opposite- or same-sex co-twin.

The activational levels of testosterone and estradiol were not related to handedness in the present study. Some earlier singleton studies have reported higher testosterone levels in right-handers (Gadea et al., 2003; Moffat & Hampson, 1996b), but those studies have comprised of small number of participants, while the present study had hormonal data on 771 subjects. The hormonal data in this study was collected at age 14 when the pubertal development is occurring. It is possible that hormonal levels during this developmental stage are not reflecting the hormonal levels later in life, so this study cannot rule out the possibility that right-handers have higher levels of testosterone as adults, as reported earlier (Gadea et al., 2003; Moffat & Hampson, 1996b). There was an expected sex difference in activational levels of testosterone and estradiol showing that males have significantly higher testosterone levels and females have significantly higher estradiol levels during puberty. The sex of a co-twin did not affect the hormonal levels, which suggests that if there was prenatal exposure to testosterone in females from opposite-sex pairs this does not have any long lasting effects on the circulating levels of testosterone and estradiol in these females.

The additional analysis of mental rotation test performance where handedness was taken into account revealed that only right-handed females with male co-twins performed better than females with female co-twins and were thus masculinized in their MRT performance. In contrast, left-handed females with male co-twins performed at the same level as females with female co-twins. Further, right-handed females with male co-twins performed significantly better than left-handed females with male co-twins, but it should be noted that there were only six left-handed individuals in that group of

females. Right-handedness in these females cannot be considered as a marker of exposure to elevated levels of testosterone (since right-handedness is predominant in all humans), but left-handedness could be regarded as evidence that there has not occurred kind of testosterone exposure that has left long lasting consequences to brain functioning. Assuming this inference is true, then the masculinization of only right-handed females with male co-twins is reasonable. Drawing further conclusions based on the data on six participants is speculative, but it offers interesting additional support for the prenatal origin of the masculinization of females with male co-twins. Socialization explanation of why only right-handed females with male co-twins are masculinized in their mental rotation performance would be difficult to postulate. Why would male co-twin affect females with male co-twins through socialization only if they were right-handed? Or why would parents encourage only right-handed females with male co-twins to engage in male typical activities?

#### **5.4 Birth and pregnancy related variables**

Most of the birth and pregnancy related variables that were included in this study were not related to handedness. This indicates that pathological events early in life do not affect the formation of handedness. The higher prevalence of left-handedness among twins and triplets compared to singletons in Study I is probably reflecting such pathological events, because these participants were born before 1958, at a time when many multiple pregnancies were not known until the labor and birth complications were more common.

Similarly, most of the birth and pregnancy related variables were not related to mental rotation performance. The only effect was the positive relationship between gestational age and MRT performance in females. This is an interesting result as it suggests that there might be prenatal events that have sex specific effect on MRT. This effect might be related to prenatal testosterone levels. In singletons gestation age has been reported to be positively related to prenatal testosterone levels only in female fetuses (Nagamani et al., 1979; Finegan et al., 1992). Thus the present finding of positive association between gestational age and MRT might give additional support for linking the prenatal testosterone levels to MRT performance in females. But it is also

possible that the greater gestational age is related to more optimal cognitive functioning in general, which is suggested by singleton studies (Bhutta, Cleves, Casey, Cradok, & Anand, 2002). But if so, why this effect was not seen in males?

## **5.5 Methodological considerations**

The measures in this study were commonly used and valid measures of handedness and mental rotation ability. First, the Vandenberg and Kuse Mental Rotation Test that was administered in the present study is probably the most commonly used paper and pencil mental rotation test and it has been shown to be the test that produces the largest and the most robust sex difference among spatial abilities (Voyer et al., 1995).

Many laterality studies have used handedness inventories (e.g. Edinburgh Handedness Inventory) and have used different cut points to make distinction between left- and right-handedness: accordingly the results have not always been comparable. Further, ambidextrous individuals have been categorised as left-handed in many studies.

A categorical handedness (i.e. left- or right-handed) measure was used in the present study, which makes the handedness definition free of seemingly arbitrary cut points. Division was made into left-/right-handed on the basis of writing hand, but also the information on self-reported handedness was utilized. The answer for these two questions did not correspond in all individuals. Individuals who reported inconsistent handedness were excluded, since they might have changed their writing hand due to injury or they might have been encouraged or forced to use their right hand for writing. In the older Finnish Twin Cohort there was also data on forced-right handedness, which makes this data unique compared to other twin studies of handedness.

Limitations of this study include the lack of direct measure of prenatal testosterone. The results can be interpreted as a evidence of prenatal testosterone transfer, but it must be kept in mind that comparing females with male co-twins to females with female co-twins is a putative indirect measure of elevated exposure to prenatal testosterone. There is no direct evidence that prenatal transfer of testosterone occurs in human twins, but at the same there are no studies that have disproved the possibility of prenatal testosterone transfer from male to female fetus in opposite-sex twin pairs.

Another limitation is related to power in the genetic modeling. Although we had very large data on handedness, there was still a lack of power to decide whether the familial effects in handedness are of genetic or common environmental origin. Similarly, there was a lack of power to detect small magnitude of common environmental effects in the sex-limitation modeling of MRT. For example, to achieve 80% power, a sample size of over 13 000 same-sex twin pairs would be needed to detect small 5% proportion of common environmental effects and over 3 000 twin pairs would be needed to detect 10% proportion of environmental effects.

The most prominent advantage in this study was that all of the studies were based on the large population based samples with high participation rates and are thus representative of Finnish twins from same-sex pairs born before 1958 and both twins from opposite- and same-sex pairs born in 1983-1987. Also, among participants in the intensive sample, the parental alcohol related problems were not related to either handedness or MRT performance, indicating that these participants were representative of all Finnish twins born in 1983-1987.

## Conclusions

In short, the present study showed that the robust neuropsychological sex differences exist also in twins: left-handedness was more common in males than in females and males outperformed females in the Mental Rotation Test. Both handedness and mental rotation ability showed heritability to some extent. Twin pairs concordant for left-handedness are very rare and, accordingly, very large samples are needed to decide whether the familial effects in handedness are of genetic or common environmental origin. Genetic effects explained about a quarter of the variance in adult writing handedness and taking forced right-handedness into account increased the genetic effects. In childhood handedness, the genetic effects were negligible. In mental rotation ability genetic effects explained about half of the variance. Both in handedness and mental rotation ability, the relative proportion of the variance explained by genetic effects were equal in males and females.

The present study gave evidence of masculinization of mental rotation ability in females with male co-twins and showed that these females have significantly higher prevalence of right-handedness than females with female co-twins. On the contrary, among males the sex of a co-twin had no effect on co-twins mental rotation ability or handedness. Whether the differences between females with male co-twins and females with female co-twins are caused by prenatal exposure to elevated levels of testosterone due to shared uterine environment with male fetus or postnatal effects could not be concluded with absolute certainty.

The results are in line with hypothesis whereby females with male co-twins are exposed to elevated levels of testosterone in their uterine environment. These results give support to view that elevated levels of prenatal testosterone levels are related to right-handedness and better mental rotation ability and warrant for further studies of differences between females with male co-twins and females with female co-twins in phenotypes that are related to testosterone. Especially studies on neuropsychological variables would be of great interest.

The results of this thesis enhance our knowledge of genetic background on laterality and mental rotation ability, and they are also suggestive of long lasting prenatal testosterone effects on these traits.

## 6 References

- Abramovich, D. R. (1974). Human sexual differentiation--in utero influences. *The Journal of Obstetrics and Gynaecology of the British Commonwealth*, 81, 448-453.
- Abramovich, D. R., & Page, K. R. (1972). Pathways of water exchange in the fetoplacental unit at mid-pregnancy. *The Journal of Obstetrics and Gynaecology of the British Commonwealth*, 79, 1099-1102.
- Aleman, A., Bronk, E., Kessels, R. P., Koppeschaar, H. P., & van Honk, J. (2004). A single administration of testosterone improves visuospatial ability in young women. *Psychoneuroendocrinology*, 29, 612-617.
- Annett, M. (1998). Handedness and cerebral dominance: The right shift theory. *The Journal of Neuropsychiatry and Clinical Neurosciences*, 10, 459-469.
- Arnold, A. P. (2009). The organizational-activational hypothesis as the foundation for a unified theory of sexual differentiation of all mammalian tissues. *Hormones and Behavior*, 55, 570-578.
- Arnold, A. P., & Gorski, R. A. (1984). Gonadal steroid induction of structural sex differences in the central nervous system. *Annual Review of Neuroscience*, 7, 413-442.
- Arnold, A. P., Xu, J., Grisham, W., Chen, X., Kim, Y. H., & Itoh, Y. (2004). Minireview: Sex chromosomes and brain sexual differentiation. *Endocrinology*, 145, 1057-1062.
- Arterberry, M. E., & Yonas, A. (2000). Perception of three-dimensional shape specified by optic flow by 8-week-old infants. *Perception & Psychophysics*, 62, 550-556.
- Auyeung, B., Baron-Cohen, S., Ashwin, E., Knickmeyer, R., Taylor, K., Hackett, G., et al. (2009). Fetal testosterone predicts sexually differentiated childhood behavior in girls and in boys. *Psychological Science*, 20, 144-148.
- Baenninger, M., & Newcombe, N. (1989). The role of experience in spatial test performance: A meta-analysis. *Sex Roles*, 20, 327-343.
- Baker, J. H., Lichtenstein, P., & Kendler, K. S. (2009). Intrauterine testosterone exposure and risk for disordered eating. *British Journal of Psychiatry*, 194, 375-376.
- Beaton, A. A. (2003). The nature and determinants of handedness. In Hugdahl, K., & Davidson, R. J. (Eds.), *The asymmetrical brain* (pp. 105-158). Cambridge, MA: MIT Press.
- Beaton, A. A., Rudling, N., Kissling, C., Taurines, R., & Thome, J. (2010). Digit ratio (2D:4D), salivary testosterone, and handedness. *Laterality*, 20, 1-20.
- Bhutta, Cleves, Casey, Craddock, & Anand. (2002). Cognitive and behavioral outcomes of school aged children who were born preterm. *Journal of American Medical Association*, 288, 728-737.
- Blatter, P. (1982). Sex differences in spatial ability: The X-linked gene theory. *Perceptual and Motor Skills*, 55, 455-462.
- Boklage, C. E. (1985). Interactions between opposite-sex dizygotic fetuses and the assumptions of Weinberg difference method epidemiology. *American Journal of Human Genetics*, 37, 591-605.
- Bouchard, T. J., Jr., & McGee, M. G. (1977). Sex differences in human spatial ability: Not an X-linked recessive gene effect. *Social Biology*, 24, 332-335.
- Breedlove, S. M., Jacobson, C. D., Gorski, R. A., & Arnold, A. P. (1982). Masculinization of the female rat spinal cord following a single neonatal injection of testosterone propionate but not estradiol benzoate. *Brain Research*, 237, 173-181.
- Bryden, P. J., Pryde, K. M., & Roy, E. A. (2000). A developmental analysis of the relationship between hand preference and performance: II. A performance-based method of measuring hand preference in children. *Brain and Cognition*, 43, 60-64.
- Cohen-Bendahan, C. C., Buitelaar, J. K., van Goozen, S. H., & Cohen-Kettenis, P. T. (2004). Prenatal exposure to testosterone and functional cerebral lateralization: A study in same-sex and opposite-sex twin girls. *Psychoneuroendocrinology*, 29, 911-916.
- Cohen-Bendahan, C. C., Buitelaar, J. K., van Goozen, S. H., Orlebeke, J. F., & Cohen-Kettenis, P. T. (2005a). Is there an effect of prenatal testosterone on aggression and other behavioral traits? A study comparing same-sex and opposite-sex twin girls. *Hormones and Behavior*, 47, 230-237.
- Cohen-Bendahan, C. C., van Goozen, S. H., Buitelaar, J. K., & Cohen-Kettenis, P. T. (2005b). Maternal serum steroid levels are unrelated to fetal sex: A study in twin pregnancies. *Twin Research and Human Genetics*, 8, 173-177.
- Cole-Harding, S., Morstad, A. L., & Wilson, J. R. (1988). Spatial ability in members of opposite-sex twin pairs. *Behavior Genetics abstracts*, 18, 710.

- Collaer, M. L., & Hines, M. (1995). Human behavioral sex differences: A role for gonadal hormones during early development? *Psychological Bulletin*, *118*, 55-107.
- Connellan, J., Baron-Cohen, S., Wheelwright, S., Batki, A., & Ahluwalia, J. (2000). Sex differences in human neonatal social perception. *Infant Behavior & Development*, *23*, 113-118.
- Corballis, M. C. (2001). Is the handedness gene on the X chromosome? Comment on Jones and Martin (2000). *Psychological Review*, *108*, 805-10.
- Corballis, M. C. (2009). The evolution and genetics of cerebral asymmetry. *Philosophical Transactions of the Royal Society of London. Series B, Biological Sciences*, *364*, 867-879.
- Corley, R. P., DeFries, J. C., Kuse, A. R., & Vandenberg, S. G. (1980). Familial resemblance for the identical blocks test of spatial ability: No evidence for X linkage. *Behavior Genetics*, *10*, 211-215.
- Culbert, K. M., Breedlove, S. M., Burt, S. A., & Klump, K. L. (2008). Prenatal hormone exposure and risk for eating disorders: A comparison of opposite-sex and same-sex twins. *Archives of General Psychiatry*, *65*, 329-336.
- De Agostini, M., Pare, C., Goudot, D., & Dellatolas, G. (1992). Manual preference and skill development in preschool children. *Developmental Neuropsychology*, *8*, 41-57.
- DeFries, J. C., Johnson, R. C., Kuse, A. R., McClearn, G. E., Polovina, J., Vandenberg, S. G., et al. (1979). Familial resemblance for specific cognitive abilities. *Behavior Genetics*, *9*, 23-43.
- Dempsey, P. J., Townsend, G. C., & Richards, L. C. (1999). Increased tooth crown size in females with twin brothers: Evidence for hormonal diffusion between human twins in utero. *American Journal of Human Biology*, *11*, 577-586
- Drolet, R., Simard, M., Plante, J., Laberge, P., & Tremblay, Y. (2007). Human type 2 17 beta-hydroxysteroid dehydrogenase mRNA and protein distribution in placental villi at mid and term pregnancy. *Reproductive Biology and Endocrinology*, *5*, 30.
- Eagly, A. H., & Wood, W. (1999). The origins of sex differences in human behavior: Evolved dispositions versus social roles. *American Psychologist*, *54*, 408-423.
- Elkadi, S., Nicholls, M. E., & Clode, D. (1999). Handedness in opposite and same-sex dizygotic twins: Testing the testosterone hypothesis. *Neuroreport*, *10*, 333-336.
- Eriksson, C. J., Kaprio, J., Pulkkinen, L., & Rose, R. J. (2005). Testosterone and alcohol use among adolescent male twins: Testing between-family associations in within-family comparisons. *Behavior Genetics*, *35*, 359-368.
- Falter, C. M., Arroyo, M., & Davis, G. J. (2006). Testosterone: Activation or Organization of spatial cognition? *Biological Psychology*, *73*, 132-140.
- Feng, J., Spence, I., & Pratt, J. (2007). Playing an action video game reduces gender differences in spatial cognition. *Psychological Science*, *18*, 850-855.
- Finegan, J-A. K., Niccols, G. A., Sitarenios, G. (1992). Relations between prenatal testosterone levels and cognitive abilities at 4 years. *Developmental Psychology*, *28*, 1075-1089.
- Fink, B., Manning, J. T., Neave, N., & Tan, U. (2004). Second to fourth digit ratio and hand skill in austrian children. *Biological Psychology*, *67*, 375-384.
- Fitch, R. H., & Denenberg, V. H. (1998). A role for ovarian hormones in sexual differentiation of the brain. *The Behavioral and Brain Sciences*, *21*, 311-27; discussion 327-52.
- Francks, C., DeLisi, L. E., Shaw, S. H., Fisher, S. E., Richardson, A. J., Stein, J. F., et al. (2003). Parent-of-origin effects on handedness and schizophrenia susceptibility on chromosome 2p12-q11. *Human Molecular Genetics*, *12*, 3225-3230.
- Francks, C., Fisher, S. E., MacPhie, I. L., Richardson, A. J., Marlow, A. J., Stein, J. F., et al. (2002). A genomewide linkage screen for relative hand skill in sibling pairs. *American Journal of Human Genetics*, *70*, 800-805.
- Francks, C., Maegawa, S., Lauren, J., Abrahams, B. S., Velayos-Baeza, A., Medland, S. E., et al. (2007). LRRTM1 on chromosome 2p12 is a maternally suppressed gene that is associated paternally with handedness and schizophrenia. *Molecular Psychiatry*, *12*, 1129-39, 1057.
- Furnham, A., Reeves, E., & Budhani, S. (2002). Parents think their sons are brighter than their daughters: Sex differences in parental self-estimations and estimations of their children's multiple intelligences. *The Journal of Genetic Psychology*, *163*, 24-39.
- Furnham, A., & Valgeirsson, H. (2007). Parents' estimations of their own intelligence and that of their children: A comparison between English and Icelandic parents. *Scandinavian Journal of Psychology*, *48*, 289-298.
- Gadea, M., Gomez, C., Gonzalez-Bono, E., Salvador, A., & Espert, R. (2003). Salivary testosterone is related to both handedness and degree of linguistic lateralization in normal women. *Psychoneuroendocrinology*, *28*, 274-287.

- Gaist, D., Bathum, L., Skytthe, A., Jensen, T. K., McGue, M., Vaupel, J. W., & Cristensen, K. (2000). Strength and anthropometric measures in identical and fraternal twins: No evidence of masculinization of females with male co-twins. *Epidemiology*, *11*, 340-343.
- Gandelman, R., vom Saal, F. S., & Reinisch, J. M. (1997). Contiguity to male fetuses affects morphology and behavior of female mice. *Nature*, *266*, 722-724.
- Geschwind, N., & Behan, P. (1982). Left-handedness: Association with immune disease, migraine, and developmental learning disorder. *Proceedings of the National Academy of Sciences of the United States of America*, *79*, 5097-5100.
- Geschwind, N., & Galaburda, A. M. (1985). Cerebral lateralization. biological mechanisms, associations, and pathology: I. A hypothesis and a program for research. *Archives of Neurology*, *42*, 428-459.
- Gilbert, A. N., & Wysocki, C. J. (1992). Hand preference and age in the United States. *Neuropsychologia*, *30*, 601-608.
- Goldsmith, H. H. (1991). A zygosity questionnaire for young twins: A research note. *Behavior Genetics*, *21*, 257-269.
- Gouchie, C., & Kimura, D. (1991). The relationship between testosterone levels and cognitive ability patterns. *Psychoneuroendocrinology*, *16*, 323-334.
- Grimshaw, G. M., Bryden, M. P., Finegan, J.-A. K., (1995a). Relations between prenatal testosterone and cerebral lateralization in children. *Neuropsychology*, *9*, 68-79.
- Grimshaw, G. M., Sitarenios, G., & Finegan, J. A. (1995b). Mental rotation at 7 years: Relations with prenatal testosterone levels and spatial play experiences. *Brain and Cognition*, *29*(1), 85-100.
- Haworth, C. M., Wright, M. J., Luciano, M., Martin, N. G., de Geus, E. J., van Beijsterveldt, C. E., et al. (2009). The heritability of general cognitive ability increases linearly from childhood to young adulthood. *Molecular Psychiatry*, in press.
- Helleday, J., Siwers, B., Ritzen, E. M., & Hugdahl, K. (1994). Normal lateralization for handedness and ear advantage in a verbal dichotic listening task in women with congenital adrenal hyperplasia (CAH). *Neuropsychologia*, *32*, 875-880.
- Henderson, B. A., & Berenbaum, S. A. (1997). Sex-typed play in opposite-sex twins. *Developmental Psychobiology*, *31*, 115-123.
- Hepper, P. G., McCartney, G. R., & Shannon, E. A. (1998). Lateralised behaviour in first trimester human fetuses. *Neuropsychologia*, *36*, 531-534.
- Hepper, P. G., Shahidullah, S., & White, R. (1991). Handedness in the human fetus. *Neuropsychologia*, *29*, 1107-1111.
- Hepper, P. G., Wells, D. L., & Lynch, C. (2005). Prenatal thumb sucking is related to postnatal handedness. *Neuropsychologia*, *43*, 313-315.
- Hines, M. (2003). Sex steroids and human behavior: Prenatal androgen exposure and sex-typical play behavior in children. *Annals of the New York Academy of Sciences*, *1007*, 272-282.
- Hines, M. (2006). Prenatal testosterone and gender-related behaviour. *European Journal of Endocrinology*, *155 Suppl 1*, S115-21.
- Hirota, K., Gomi, T., Kishimoto, R., Iguchi, M., Hayakawa, K., & Nakagawa, H. (1981). Androgen receptor in human placental villi. *Journal of Biochemistry*, *89*, 153-160.
- Hooven, C. K., Chabris, C. F., Ellison, P. T., & Kosslyn, S. M. (2004). The relationship of male testosterone to components of mental rotation. *Neuropsychologia*, *42*, 782-790.
- Janowsky, J. S. (2006). Thinking with your gonads: Testosterone and cognition. *Trends in Cognitive Sciences*, *10*, 77-82.
- Johnson, S. P., Cohen, L. B., Marks, K. H., & Johnson, K. L. (2003). Young infants' perception of object unity in rotation displays. *Infancy*, *4*, 285-295.
- Jones, G. V., & Martin, M. (2000). A note on Corballis (1997) and the genetics and evolution of handedness: Developing a unified distributional model from the sex-chromosomes gene hypothesis. *Psychological Review*, *107*, 213-218.
- Jones, G. V., & Martin, M. (2010). Language dominance, handedness and sex: Recessive X-linkage theory and test. *Cortex*, *46*, 781-786.
- Kaprio, J., & Koskenvuo, M. (2002). Genetic and environmental factors in complex diseases: The older Finnish Twin Cohort. *Twin Research*, *5*, 358-365.
- Kaprio, J., & Marttila, R. (2005). Demographic trends in Nordic countries. In I. Blickstein, & L. G. Keith (Eds.), *Multiple pregnancy: Epidemiology, gestation & perinatal outcome*. (2nd ed., pp. 22-25). London: Taylor & Francis.
- Kaprio, J., Pulkkinen, L., & Rose, R. J. (2002). Genetic and environmental factors in health-related behaviors: Studies on Finnish twins and twin families. *Twin Research*, *5*, 366-371.



- Kelso, W. M., Nicholls, M. E., Warne, G. L., & Zacharin, M. (2000). Cerebral lateralization and cognitive functioning in patients with congenital adrenal hyperplasia. *Neuropsychology, 14*, 370-378.
- Kerns, K. A., & Berenbaum, S. A. (1991). Sex differences in spatial ability in children. *Behavior Genetics, 21*, 383-396.
- Knecht, S., Drager, B., Deppe, M., Bobe, L., Lohmann, H., Floel, A., et al. (2000). Handedness and hemispheric language dominance in healthy humans. *Brain, 123*, 2512-2518.
- Kremen, W. S., Eisen, S. A., Tsuang, M. T., & Lyons, M. J. (2007). Is the Wisconsin Card Sorting Test a useful neurocognitive endophenotype? *American Journal of Medical Genetics. Part B, Neuropsychiatric Genetics, 144B*, 403-406.
- Kristenson, H., & Trelle, E. (1982). Indicators of alcohol consumption: Comparisons between a questionnaire (mm-MAST), interviews and serum gamma-glutamyl transferase (GGT) in a health survey of middle-aged males. *British Journal of Addiction, 77*, 297-304.
- Laval, S. H., Dann, J. C., Butler, R. J., Loftus, J., Rue, J., Leask, S. J., et al. (1998). Evidence for linkage to psychosis and cerebral asymmetry (relative hand skill) on the X chromosome. *American Journal of Medical Genetics, 81*, 420-427.
- Law, D. L., Pellegrino, J. W., & Hunt, E. B. (1993). Comparing the tortoise and the hare: Gender and experience in dynamic spatial reasoning tasks. *Psychological Science, 49*, 35-40.
- Lippa, R. A., Collaer, M. L., & Peters, M. (2010). Sex differences in mental rotation and line angle judgments are positively associated with gender equality and economic development across 53 nations. *Archives of Sexual Behavior, 39*, 990-997.
- Loehlin, J. C., & Martin, N. G. (2000). Dimensions of psychological masculinity-femininity in adult twins from opposite-sex and same-sex pairs. *Behavior Genetics, 30*, 19-28.
- Lummaa, V., Pettay, J. E., & Russell, A. F. (2007). Male twins reduce fitness of female co-twins in humans. *Proceedings of the National Academy of Sciences of the United States of America, 104*, 10915-10920.
- Lyons, M. J., York, T. P., Franz, C. E., Grant, M. D., Eaves, L. J., Jacobson, K. C., et al. (2009). Genes determine stability and the environment determines change in cognitive ability during 35 years of adulthood. *Psychological Science, 20*, 1146-1152.
- Lytton, H., & Romney, D. M. (1991). Parents' differential socialization of boys and girls: A meta-analysis. *Psychological Bulletin, 109*, 267-296.
- Manning, J.T. (2002). *Digit ratio: A pointer to fertility, behaviour, and health*. New Brunswick, Rutgers University Press.
- Manning, J. T., & Peters, M. (2009). Digit ratio (2D:4D) and hand preference for writing in the BBC internet study. *Laterality, 14*, 528-540.
- Manning, J. T., Trivers, R. L., Thornhill, R., & Singh, D. (2000). The 2nd:4th digit ratio and asymmetry of hand performance in jamaican children. *Laterality, 5*, 121-132.
- Mathews, G. A., Fane, B. A., Pasterski, V. L., Conway, G. S., Brook, C., & Hines, M. (2004). Androgenic influences on neural asymmetry: Handedness and language lateralization in individuals with congenital adrenal hyperplasia. *Psychoneuroendocrinology, 29*, 810-822.
- Matousek, R. H., & Sherwin, B. B. (2010). Sex steroid hormones and cognitive functioning in healthy, older men. *Hormones and Behavior, 57*, 352-359.
- McClurg, P. A., & Chaille, C. (1987). Computer games: Environments for developing spatial cognition. *Journal of Educational Computing Research, 3*, 95-111.
- McCormick, P. D., Razel, A. J., Spelsberg, T. C., & Coulam, C. B. (1981). Evidence for an androgen receptor in the human placenta. *American Journal of Obstetrics and Gynecology, 140*, 8-13.
- McFadden, D. (1993). A masculinizing effect on the auditory systems of human females having male co-twins. *Proceedings of the National Academy of Sciences of the United States of America, 90*, 11900-11904.
- McManus, I. C. (1985). Right- and left-hand skill: Failure of the right shift model. *British Journal of Psychology, 76*, 1-34.
- McManus, I. C. (2010). Precisely wrong? the problems with the Jones and Martin genetic model of sex differences in handedness and language lateralisation. *Cortex, 46*, 700-702.
- McManus, I. C., & Bryden, M. P. (1992). The genetics of handedness, cerebral dominance, and lateralization. In I. Rapin, & S. J. Segalowitz (Eds.), *Handbook of neuropsychology* (pp. 115-144). Amsterdam: Elsevier Science Publishers.
- Medland, S. E., Duffy, D. L., Spurdle, A. B., Wright, M. J., Geffen, G. M., Montgomery, G. W., et al. (2005). Opposite effects of androgen receptor CAG repeat length on increased risk of left-handedness in males and females. *Behavior Genetics, 35*, 735-744.

- Medland, S. E., Duffy, D. L., Wright, M. J., Geffen, G. M., Hay, D. A., Levy, F., et al. (2009). Genetic influences on handedness: Data from 25,732 Australian and Dutch twin families. *Neuropsychologia*, *47*, 330-337.
- Medland, S. E., Duffy, D. L., Wright, M. J., Geffen, G. M., & Martin, N. G. (2006). Handedness in twins: Joint analysis of data from 35 samples. *Twin Research and Human Genetics*, *9*, 46-53.
- Medland, S. E., Loehlin, J. C., & Martin, N. G. (2008a). No effects of prenatal hormone transfer on digit ratio in a large sample of same- and opposite-sex dizygotic twins. *Personality and Individual Differences*, *44*, 1225-1234.
- Medland, S. E., Loehlin, J. C., Willemsen, G., Hatemi, P. K., Keller, M. C., Boomsma, D. I., et al. (2008b). Males do not reduce the fitness of their female co-twins in contemporary samples. *Twin Research and Human Genetics*, *11*, 481-487.
- Medland, S. E., Perelle, I., De Monte, V., & Ehrman, L. (2004). Effects of culture, sex, and age on the distribution of handedness: An evaluation of the sensitivity of three measures of handedness. *Laterality*, *9*, 287-297.
- Meisel, R. L., & Ward, I. L. (1981). Fetal female rats are masculinized by male littermates located caudally in the uterus. *Science*, *213*, 239-242.
- Miller, E., M. (1994). Prenatal sex hormone transfer: A reason to study opposite-sex twins. *Personality and Individual Differences*, *17*, 511-529.
- Moffat, S. D., & Hampson, E. (1996a). A curvilinear relationship between testosterone and spatial cognition in humans: Possible influence of hand preference. *Psychoneuroendocrinology*, *21*, 323-337.
- Moffat, S. D., & Hampson, E. (1996b). Salivary testosterone levels in left- and right-handed adults. *Neuropsychologia*, *34*, 225-233.
- Moffat, S. D., & Hampson, E. (2000). Salivary testosterone concentrations in left-handers: An association with cerebral language lateralization? *Neuropsychology*, *14*, 71-81.
- Moore, D. S., & Johnson, S. P. (2008). Mental rotation in human infants: A sex difference. *Psychological Science*, *19*, 1063-1066.
- Morley-Fletcher, S., Palanza, P., Parolaro, D., Vigano, D., & Laviola, G. (2003). Intrauterine position has long-term influence on brain mu-opioid receptor density and behaviour in mice. *Psychoneuroendocrinology*, *28*, 386-400.
- Nagamani, M., McDonough, P. G., Ellegood, J. O., & Mahesh, V. B. (1979). Maternal and amniotic fluid steroids throughout human pregnancy. *American Journal of Obstetrics and Gynecology*, *134*, 674-680.
- Nass, R., Baker, S., Speiser, P., Viridis, R., Balsamo, A., Cacciari, E., et al. (1987). Hormones and handedness: Left-hand bias in female congenital adrenal hyperplasia patients. *Neurology*, *37*, 711-715.
- Neale, M. C., Boker, S. M., Xie, G., & Maes, H. H. (2003). *Mx: Statistical Modeling* (6<sup>th</sup> Edition). Richmond, VA: 23298 Department of Psychiatry.
- Nicholls, M. E., Orr, C. A., Yates, M. J., & Loftus, A. M. (2008). A new means of measuring index/ring finger (2D:4D) ratio and its association with gender and hand preference. *Laterality*, *13*, 71-91.
- Oldfield, R. C. (1971). The assessment and analysis of handedness: The Edinburgh inventory. *Neuropsychologia*, *9*, 97-113.
- Ooki, S. (2005). Genetic and environmental influences on the handedness and footedness in Japanese twin children. *Twin Research and Human Genetics*, *8*, 649-656.
- Papadatou-Pastou, M., Martin, M., Munafo, M. R., & Jones, G. V. (2008). Sex differences in left-handedness: A meta-analysis of 144 studies. *Psychological Bulletin*, *134*, 677-699.
- Park, J., Johnson, R. C., DeFries, J. C., McClearn, G. E., Mi, M. P., Rashad, M. N., et al. (1978). Parent offspring resemblance for specific cognitive abilities in Korea. *Behavior Genetics*, *8*, 43-52.
- Perelle, I. B., & Ehrman, L. (1994). An international study of human handedness: The data. *Behavior Genetics*, *24*, 217-227.
- Peters, M. (2005). Sex differences and the factor of time in solving Vandenberg and Kuse mental rotation problems. *Brain and Cognition*, *57*, 176-184.
- Peters, M., Laeng, B., Latham, K., Jackson, M., Zaiyouna, R., & Richardson, C. (1995). A redrawn Vandenberg and Kuse mental rotations test: Different versions and factors that affect performance. *Brain and Cognition*, *28*, 39-58.
- Peters, M., Lehmann, W., Takahira, S., Takeuchi, Y., & Jordan, K. (2006). Mental rotation test performance in four cross-cultural samples (n = 3367): Overall sex differences and the role of academic program in performance. *Cortex*, *42*, 1005-1014.

- Peters, M., Manning, J. T., & Reimers, S. (2007). The effects of sex, sexual orientation, and digit ratio (2D:4D) on mental rotation performance. *Archives of Sexual Behavior, 36*, 251-260.
- Peters, M., Reimers, S., & Manning, J. T. (2006). Hand preference for writing and associations with selected demographic and behavioral variables in 255,100 subjects: The BBC internet study. *Brain and Cognition, 62*, 177-189.
- Phoenix, C. H., Goy, R. W., Gerall, A. A., & Young, W. C. (1959). Organizing action of prenatally administered testosterone propionate on the tissues mediating mating behavior in the female guinea pig. *Endocrinology, 65*, 369-382.
- Plomin, R., DeFries, J. C., McClearn, G. E., & McGuffin, P. (2008). *Behavior Genetics* (pp. 173-193). New York: Worth Publishers.
- Plomin, R., Fulker, D. W., Corley, R., & DeFries, J. C. (1997). Nature, nurture, and cognitive development from 1 to 16 years: A parent-offspring adoption study. *Psychological Science, 8*, 442-447.
- Pulkkinen, L., Vaalamo, I., Hietala, R., Kaprio, J., & Rose, R. J. (2003). Peer reports of adaptive behavior in twins and singletons: Is twinship a risk or an advantage? *Twin Research, 6*, 106-118.
- Puts, D. A., Cardenas, R. A., Bailey, D. H., Burriss, R. P., Jordan, C. L., & Breedlove, S. M. (2010). Salivary testosterone does not predict mental rotation performance in men or women. *Hormones and Behavior, 58*, 282-289.
- Puts, D. A., McDaniel, M. A., Jordan, C. L., & Breedlove, S. M. (2008). Spatial ability and prenatal androgens: Meta-analyses of congenital adrenal hyperplasia and digit ratio (2D:4D) studies. *Archives of Sexual Behavior, 37*, 100-111.
- Quaiser-Pohl, C., & Lehmann, W. (2002). Girls' spatial abilities: Charting the contributions of experiences and attitudes in different academic groups. *The British Journal of Educational Psychology, 72*, 245-260.
- Quinn, P. C., & Liben, L. S. (2008). A sex difference in mental rotation in young infants. *Psychological Science, 19*, 1067-1070.
- Raeuuri, A., Kaprio, J., Hoek, H. W., Sihvola, E., Rissanen, A., & Keski-Rahkonen, A. (2008). Anorexia and bulimia nervosa in same-sex and opposite-sex twins: Lack of association with twin type in a nationwide study of Finnish twins. *The American Journal of Psychiatry, 165*, 1604-1610.
- Ramadhani, M. K., Koomen, I., Grobbee, D. E., van Donselaar, C. A., Marceline van Furth, A., & Uiterwaal, C. S. (2006). Increased occurrence of left-handedness after severe childhood bacterial meningitis: Support for the pathological left-handedness hypothesis. *Neuropsychologia, 44*, 2526-2532.
- Rao, J. N., & Scott, A. J. (1984). On chi-squared tests for multiway contingency tables with cell proportions estimated from survey data. *Annals of Statistics, 12*, 46-60.
- Read, S., Pedersen, N. L., Gatz, M., Berg, S., Vuoksimaa, E., Malmberg, B., et al. (2006). Sex differences after all those years? heritability of cognitive abilities in old age. *The Journals of Gerontology. Series B, Psychological Sciences and Social Sciences, 61*, P137-43.
- Resnick, S. M., Gottesman, I. I., McGue, M. (1993). Sensation seeking in opposite-sex twins: An effect of prenatal hormones? *Behavior Genetics, 23*, 323-329.
- Reyes, F. I., Boroditsky, R. S., Winter, J. S., & Faiman, C. (1974). Studies on human sexual development. II. Fetal and maternal serum gonadotropin and sex steroid concentrations. *The Journal of Clinical Endocrinology and Metabolism, 38*, 612-617.
- Roberts, E. K., Padmanabhan, V., & Lee, T. M. (2008). Differential effects of prenatal testosterone timing and duration on phenotypic and behavioral masculinization and defeminization of female sheep. *Biology of Reproduction, 79*, 43-50.
- Rose, R. J., Kaprio, J., Winter, T., Dick, D. M., Viken, R. J., Pulkkinen, L., et al. (2002). Femininity and fertility in sisters with twin brothers: Prenatal androgenization? Cross-sex socialization? *Psychological Science, 13*, 263-267.
- Ross, J. L., Roeltgen, D. P., Stefanatos, G., Benecke, R., Zeger, M. P., Kushner, H., et al. (2008). Cognitive and motor development during childhood in boys with Klinefelter syndrome. *American Journal of Medical Genetics. Part A, 146*, 708-719.
- Rust, J., Golombok, S., Hines, M., Johnston, K., Golding, J., & ALSPAC Study Team. (2000). The role of brothers and sisters in the gender development of preschool children. *Journal of Experimental Child Psychology, 77*, 292-303.
- Ryan, B. C., & Vandenbergh, J. G. (2002). Intrauterine position effects. *Neuroscience and Biobehavioral Reviews, 26*, 665-678.

- Sarna, S., Kaprio, J., Sistonen, P., & Koskenvuo, M. (1978). Diagnosis of twin zygoty by mailed questionnaire. *Human Heredity*, 28, 241-254.
- Seppa, K., Sillanauke, P., & Koivula, T. (1990). The efficiency of a questionnaire in detecting heavy drinkers. *British Journal of Addiction*, 85, 1639-1645.
- Shepard, R. N., & Metzler, J. (1971). Mental rotation of three-dimensional objects. *Science*, 171, 701-703.
- Silverman, I., Choi, J., & Peters, M. (2007). The hunter-gatherer theory of sex differences in spatial abilities: Data from 40 countries. *Archives of Sexual Behavior*, 36, 261-268.
- Sommer, I. E., Aleman, A., Somers, M., Boks, M. P., & Kahn, R. S. (2008). Sex differences in handedness, asymmetry of the planum temporale and functional language lateralization. *Brain Research*, 1206, 76-88.
- Spss (2008). *SPSS: Version 16*. SPSS Inc., Chicago, Ill.
- Stata (2006). *Stata statistical software: Release 9.1*. College Station, TX: Stata Corporation.
- Steele, C. M. (1997). A threat in the air. how stereotypes shape intellectual identity and performance. *The American Psychologist*, 52, 613-629.
- Van Agtmael, T., Forrest, S. M., & Williamson, R. (2002). Parametric and non-parametric linkage analysis of several candidate regions for genes for human handedness. *European Journal of Human Genetics*, 10, 623-630.
- Van Anders, S. M., Vernon, P. A., & Wilbur, C. J. (2006). Finger-length ratios show evidence of prenatal hormone-transfer between opposite-sex twins. *Hormones and Behavior*, 49, 315-319.
- Vandenberg, S. G. (1969). A twin study of spatial ability. *Multivariate Behavioral Research*, 4, 273-294.
- von Stumm, S., Chamorro-Premuzic, T., & Furnham, A. (2009). Decomposing self-estimates of intelligence: Structure and sex differences across 12 nations. *British Journal of Psychology*, 100, 429-442.
- Voracek, M., & Dressler, S. G. (2007). Digit ratio (2D:4D) in twins: Heritability estimates and evidence for a masculinized trait expression in women from opposite-sex pairs. *Psychological Reports*, 100, 115-126.
- Voyer, D., Voyer, S., & Bryden, M. P. (1995). Magnitude of sex differences in spatial abilities: A meta-analysis and consideration of critical variables. *Psychological Bulletin*, 117, 250-270.
- Vuoksimaa, E., Viken, R., Raevuori, A., Tuulio-Henriksson, A., Kaprio, J., & Rose, R. J. (2009). Associations between self-estimated and measured intelligence and self-esteem [Behavior Genetics Association Meeting Abstract]. *Behavior Genetics*, 39, 688.
- Walker, J. T., Krasnoff, A. G., & Peaco, D. (1981). Visual spatial perception in adolescents and their parents: The X-linked recessive hypothesis. *Behavior Genetics*, 11, 403-413.
- Warne, G. L., Faiman, C., Reyes, F. I., & Winter, J. S. (1977). Studies on human sexual development. V. Concentrations of testosterone, 17-hydroxyprogesterone and progesterone in human amniotic fluid throughout gestation. *The Journal of Clinical Endocrinology and Metabolism*, 44, 934-938.
- Warne, G. L., Reyes, F. I., Faiman, C., & Winter, J. S. (1978). Studies on human sexual development. VI. Concentrations of unconjugated dehydroepiandrosterone, estradiol, and estriol in amniotic fluid throughout gestation. *The Journal of Clinical Endocrinology and Metabolism*, 47, 1363-1367.
- Warren, D. M., Stern, M., Duggirala, R., Dyer, T. D., & Almasy, L. (2006). Heritability and linkage analysis of hand, foot, and eye preference in Mexican Americans. *Laterality*, 11, 508-524.
- Williams, C. L., & Meck, W. H. (1991). The organizational effects of gonadal steroids on sexually dimorphic spatial ability. *Psychoneuroendocrinology*, 16, 155-176.
- Williams, C. S., Buss, K. A., & Eskenazi, B. (1992). Infant resuscitation is associated with an increased risk of left-handedness. *American Journal of Epidemiology*, 136, 277-286.
- Williams, R. L. (2000). A note on robust variance estimation for cluster-correlated data. *Biometrics*, 56, 645-646.
- Witelson, S. F. (1991). Neural sexual mosaicism: Sexual differentiation of the human temporo-parietal region for functional asymmetry. *Psychoneuroendocrinology*, 16, 131-153.
- Witelson, S. F., & Nowakowski, R. S. (1991). Left out axons make men right: A hypothesis for the origin of handedness and functional asymmetry. *Neuropsychologia*, 29, 327-333.
- Wood, W., & Eagly, A. H. (2002). A cross-cultural analysis of the behavior of women and men: Implications for the origins of sex differences. *Psychological Bulletin*, 128, 699-727.
- Wraga, M., Helt, M., Jacobs, E., & Sullivan, K. (2007). Neural basis of stereotype-induced shifts in women's mental rotation performance. *Social Cognitive and Affective Neuroscience*, 2, 12-19.

Ypsilanti, A., Ganou, M., Koidou, I., & Grouios, G. (2008). Digit ratio (2D:4D) in individuals with intellectual disability: Investigating the role of testosterone in the establishment of cerebral lateralisation. *Laterality*, *13*, 527-544.