

Accepted Manuscript

Title: A Low-Cost, Portable Optical Explosive-vapour Sensor

Authors: Ross N. Gillanders, Ifor D.W. Samuel, Graham A. Turnbull

PII: S0925-4005(17)30185-5
DOI: <http://dx.doi.org/doi:10.1016/j.snb.2017.01.178>
Reference: SNB 21703

To appear in: *Sensors and Actuators B*

Received date: 10-8-2016
Revised date: 17-1-2017
Accepted date: 26-1-2017



Please cite this article as: Ross N.Gillanders, Ifor D.W.Samuel, Graham A.Turnbull, A Low-Cost, Portable Optical Explosive-vapour Sensor, Sensors and Actuators B: Chemical <http://dx.doi.org/10.1016/j.snb.2017.01.178>

This is a PDF file of an unedited manuscript that has been accepted for publication. As a service to our customers we are providing this early version of the manuscript. The manuscript will undergo copyediting, typesetting, and review of the resulting proof before it is published in its final form. Please note that during the production process errors may be discovered which could affect the content, and all legal disclaimers that apply to the journal pertain.

A Low-Cost, Portable Optical Explosive-vapour Sensor

Ross N. Gillanders, Ifor D.W. Samuel, Graham A. Turnbull

Organic Semiconductor Centre, SUPA, School of Physics & Astronomy, University of St Andrews, Fife
KY16 9SS, Scotland

Highlights

- Arduino-based optical instrument for explosives detection designed and prototyped
- Few-ppb detection of 2,4-DNT achieved under laboratory conditions with simple photodiode circuitry and off-the-shelf microprocessor
- Simulated buried landmines successfully detected

Abstract

Humanitarian demining requires a broad range of methodologies and instrumentation for reliable identification of landmines, antipersonnel mines, and other explosive remnants of war (ERWs). Optical sensing methods are ideal for this purpose due to advantages in sensitivity, time-of-response and small form factor. In this work we present a portable photoluminescence-based sensor for nitroaromatic vapours based on the conjugated polymer Super Yellow integrated into an instrument

comprising an excitation LED, photodiode, Arduino microprocessor and pumping mechanics for vapour delivery. The instrument was shown to be sensitive to few-ppb concentrations of explosive vapours under laboratory conditions, and responds to simulated buried landmine vapour. The results indicate that a lightweight, easy-to-operate, low-cost and highly-sensitive optical sensor can be readily constructed for landmine and ERW detection in the field, with potential to aid worldwide efforts in landmine mitigation.

Keywords: Explosives detection; Super Yellow; Arduino; Photoluminescence; ERW; Humanitarian Demining

1. Introduction

Global conflicts over decades have seen a legacy of landmines and Explosive Remnants of War (ERWs) left buried and active long after the conflicts themselves may be over. In addition to their inherent danger, the presence of mines prevents trade, communication and land use among local peoples. While several demining techniques are presently used successfully, there is still a pressing need in current humanitarian demining for rapid-response in-situ measurement techniques appropriate to a wide range of environments, since existing methods are not necessarily able to operate over extended periods of time in the field. Common methods such as canines have stringent and limited working practice in the field, in addition to occasional unpredictability or fitness-to-work of the canines [1, 2]. Other commonly-used techniques, such as metal detection, can flag false positives like harmless fragments of metal [3]; others have intrinsic high danger, such as prodders which require a deminer to physically push at the landmine. Detection of vapours given off by landmines, such as tri-nitrotoluene (TNT) or its derivative di-nitrotoluene (2,4-DNT), can potentially complement the above

methods to mitigate these issues, since the non-contact nature of vapour detection allows one to identify a landmine that may be missed by other methods, for instance a plastic mine being missed by a metal detector. A hand-held, in-situ and sensitive system based on explosive vapour sensing would provide an extremely useful tool in the field for demining.

In the development of a low-cost and field-serviceable instrument, an Arduino Uno, from the Arduino family of off-the-shelf development kits that have been receiving increasing interest since their release in 2012, can be a suitable microprocessor to handle signal capture and A/D conversion. Recent work has shown Arduino platforms integrated into optical sensing systems, for instance for Copper (II) ions [4] and Volatile Organic Compounds in seawater [5]. Another advantage to these platforms is that the device can be flashed with firmware allowing the device to function without the need for external control software from e.g. a laptop computer. Simple functionality such as this allows for an “on/off” version of the system, where an alert can be made by buzzer or warning light to indicate the detection of explosive vapours, allowing a simple deployment.

There have been extensive studies on conjugated polymer films for explosives detection [6-12]. Conjugated polymers have great potential for humanitarian demining due to the high sensitivity of their light emission to the presence of nitroaromatic compounds. The sensing mechanism is based on the transfer of an electron from a photo-excited exciton state in an electron-rich polymer to an electron-deficient adsorbed molecule from the vapours, resulting in a loss of light emission. The light emission is quenched, in proportion to the level of nitroaromatic vapour present, as this photo-induced electron transfer provides a non-radiative pathway for the exciton to relax. This reduction in light intensity can subsequently be monitored using a photodiode, aiding development of low-cost, compact optical sensors. Since the polymers are typically spin-coated to give films a few tens of nm thickness on glass substrates, the sensor films can be produced in large enough quantities for disposable use after positive identification of explosives. The commercially-available polymer Merck Super Yellow, part of the PPV group of conjugated polymers and illustrated in Figure 1, has previously

been shown to have a high PLQY [13]. The chemical properties of this material has been characterised in other work for applications as polymer LEDs (PLEDs) [14], and displays high sensitivity to nitroaromatic vapours with 2,4-DNT giving a significant quenching effect [12].

In this work we present a small-form, low-cost, robust, easy-to-use and field-serviceable optical sensor for explosive vapours to help address the challenges involved in humanitarian demining. It is anticipated to be able to be used in conjunction with established humanitarian demining technologies to aid in reduction of false negatives and contribute to a more comprehensive surveying suite of technologies.

2. Experimental

2.1 Film fabrication & characterisation

Films based on the conjugated polymer Super Yellow (supplied by Merck) were prepared by spin-coating, at 2000 rpm, from a 6.5 mg/ml solution of the polymer in toluene onto 1 cm x 1 cm glass coverslips from Agar Scientific. The film thickness was measured using a Veeco Dektak 150 surface profiler and films were typically 100 nm thick. The film thickness has previously been shown to affect the speed of response to vapours due to molecules penetrating the polymer matrix at a fixed rate [9], and so films of 100 nm thickness were chosen to allow a fast response to the vapour. Photoluminescence Quantum Yield (PLQY) measurements were performed in an integrating sphere [15], using a Hamamatsu Photonics C9920-02 measurement system with an excitation wavelength of 440 nm. Absorption and emission spectra were measured with a Cary 300 Bio UV-Vis absorption spectrometer and Edinburgh Instruments FLS980 Fluorescence spectrometer respectively.

2.2 System architecture

The system operates by a polymer film being loaded into an airtight sample chamber with windows on each side to allow excitation by an LED, and collection of photoluminescent emission by a photodiode. The vapour is drawn via the bottom face of the enclosure by a pump, past the polymer film, and out via an exhaust line. The pump and LED are switched on manually by switches on the enclosure, with emission data being processed on an Arduino microprocessor prior to being sent via USB to a laptop.

Figure 2(a) shows a schematic of the system architecture, with a photograph of the system with lid removed in Figure 2(b) and a photograph of the sample-loading mechanism in Figure 2(c). The LED was a high-power Royal Blue LUXEON LED from Philips, driven by a 9V battery and standard LED driver circuitry. The emission spectrum of the LED, with a peak wavelength of 447.5 nm, closely matches the absorption of the Super Yellow polymer with an absorption peak at 440 nm. The detection module of the sensing system was constructed of a Hamamatsu S2386-44K photodiode with high-sensitivity and low-noise, integrated with an Analog Devices AD8015ARZ low-power transimpedance amplifier, as illustrated in figure 3. The DC-powered PCB was designed to fit directly on the surface of the Arduino via analogue input pin A0. The detector module was held in a home-made adjustable bracket to allow vertical and horizontal movement of the photodiode for alignment. The Arduino was addressed to a VI in LabView via USB connection, and communication was achieved via LabView MakerHub, a tool for interfacing platforms such as Arduino to National Instruments software. The LabView Graphical User Interface (GUI) displays both the raw data signal and the signal smoothed by moving-average, to account for random noise fluctuation, in real-time and both sets of data were saved automatically in an Excel sheet for further data processing. The GUI is illustrated in Figure 4.

The enclosure was an IP67-rated enclosure from FIBOX with dimensions of 188 x 188 x 130 mm. The enclosure was fitted with a purpose-built platform to stabilise the component parts; a USB connector and switches for the pump and LED were also mounted on the enclosure. An in-house built stainless steel sensing chamber was designed to have a lock mechanism to enable ease of sensor film

replacement in the field, with two windows for excitation and emission and the film aligned with the windows. The LED was mounted on one side of the sensing chamber to illuminate the film through one window. The fluorescence was collected through the other window using a 20 mm focal length aspheric condenser lens from Thorlabs focussed onto the photodiode. Air samples were drawn in through a stainless steel tube on the bottom face of the enclosure via a path length of approximately 1 cm, through the sample chamber and out via exhaust on the rear side of the enclosure by a micropump from TCS Pumps, with 600 ml/min maximum flow and powered by 9V battery. For studies with Super Yellow, a 550 nm long pass filter from Thorlabs was used to the signal emission from residual excitation light. The entire system weighs approximately 2.1 kg.

(a)

2.3 Procedure for Measuring Response to Calibrated Flow of Explosive Vapours

To assess the system's response to explosive vapours, it was first attached to a benchtop vapour delivery apparatus, with a clean N₂ line and a line with N₂ gas contaminated with 1 g of 2,4-DNT (Sigma Aldrich) connected to the inlet of the system. The system was flushed with clean N₂ for several seconds and the data acquisition software started before 2,4-DNT vapour was introduced to the chamber, bypassing the pump mechanism. The measurement was made at a sample rate of 1 Hz over approximately 2 minutes, and the decrease in photoluminescence emission was monitored over time. The system was flushed with clean N₂ after each run to prevent contamination of the sensing chamber.

2.4 Simulated buried landmines

Simulated buried landmines were prepared with 1 g of a TNT-containing composite material or 2,4-DNT in a metal or plastic container with holes drilled into the lid to allow for vapour release, and buried in soil or sand at a depth of 2 cm, 5 cm or 10 cm in clay pots. Blank samples were made by placing empty containers below the soil or sand surface in clay pots. The TNT samples inside the containers

are NESTT materials from www.xm-materials.com which are comprised of silica particles coated with the explosive material (~8% explosive). The samples were securely held in a glove box for one year prior to testing to allow diffusion of the vapour molecules to the surface, and to provide a controlled environment, with humidity and temperature inside the sealed box constant at 28% RTH and 23°C. To make a measurement the sensor system was positioned over the pot and ambient air drawn through the sample chamber by the pump. The LED was turned on and data collection started shortly prior to air pumping, with the system inlet approximately 1 cm from the sand/soil surface. Measurements were taken at 1 Hz sample rate for approximately 100 seconds. Clean air was pumped through the sample chamber between measurements to avoid contamination or residual explosive particles within the sensing chamber.

3. Results and discussion

3.1 Merck Super Yellow film characteristics

To enable close spectral matching of the system excitation LED and optical emission filter with the photophysical properties of the polymer, the absorption and emission spectra of Super Yellow films of 100 nm thickness was measured. As shown in Figure 5, the absorption band of Super Yellow is quite broad, with a peak at 440 nm, while the emission spectrum, with $\lambda_{\text{ex}} = 440$ nm, shows a peak at 590 nm giving a relatively large Stokes' Shift of 150 nm. This large separation between excitation and emission wavelengths allows optical filtering above 550 nm to readily block the vast majority of excitation light. The film PLQY was measured to be 40%.

3.2 System response to 2,4-DNT vapour flow

The detection system was attached on one side of the sensing chamber used in previous explosives detection studies [6-8, 12]. Clean nitrogen was purged for a few seconds through the chamber prior to the 2,4-DNT vapour-line being introduced. Figure 6 shows the photoluminescence quenching by 2,4-DNT reducing emission intensity by approximately 63% over 100 seconds. The emission can be seen to drop by 30% in the first 10 seconds of measurement with a subsequent decrease in quenching over time, indicating saturation of available quenching sites. By contrast, the clean control line shows a drop in emission intensity by around 3.5%, attributable to minor degradation of the polymer under illumination. We estimate the Limit of Detection (LoD) to be $1/30^{\text{th}}$ of the vapour concentration present in the experiment, which sets a maximum bound of 30 ppb (assuming a saturated vapour pressure of DNT), but is likely to be significantly lower than this.

While some conjugated polymers can be recycled via nitrogen flushing, Super Yellow films only show partial reversibility with the application of heat to release the adsorbed explosive molecules. The films do not return to the original intensity levels probably due to residual nitro aromatic molecules from the vapour retained within the polymer matrix.

3.3 Buried explosives

Figure 7 shows the Super Yellow emission intensity response to 2,4-DNT from several simulated buried landmines, with a control emission intensity. The sensing system was placed around a centimetre above the surface of each clay pot containing a simulated mine. The excitation LED and micropump were switched on, and the emission monitored in real-time at a sample rate of 1 Hz. The control measurement was taken by pumping ambient air in a non-explosive environment with the excitation LED switched on; the straight-line decrease in intensity can be attributed to degradation of the polymer under intense illumination in air [16, 17]. However, a much faster exponential decrease in intensity can be clearly observed when the film is in contact with explosive vapours.

TNT vapour was also readily detected by the system. It is known that TNT has a lower vapour pressure of 9.15 ppb compared to 411 ppb for 2,4-DNT [18], and does not have as strong a quenching effect on Super Yellow as does 2,4-DNT [12]. Super Yellow films were used to detect two 2,4-DNT samples, a TNT sample under the same conditions, and a control sample as before. Figure 8 shows the response for all four samples, with the Super Yellow being quenched by around 65% by 2,4-DNT, and 45% by TNT. The attributes of these responses are shown in Table 1, where a clear difference in Quenching Efficiency (QE) over 100 s and Slope at 10 s is readily apparent between the buried explosive vapours, including the nitroaromatic molecule, the container material, burial media, and burial depth, and the control mine.

Table 2 shows the range of measured QE at 100 s and slope between 0 and 10 s for a range of simulated buried landmines. It can be seen that a high quenching efficiency is observed from all buried explosives, hence the amount of vapour present above the surface after one year is sufficient to be detected with the system at a distance of approximately 1 – 2 cm from the surface and the inlet of the system.

4 Conclusion

We have demonstrated a portable, low-cost optical explosives vapour sensor based on quenching of photoluminescence from the conjugated polymer Super Yellow. The hardware was designed and developed to be modular and user-friendly in the field by utilising off-the-shelf components, such as the Arduino microprocessor, in addition to low power requirements and a lightweight form. The photoluminescence was significantly quenched by vapours from buried simulated landmines containing 2,4-DNT and TNT, at concentrations of approximately 400 ppb and 9 ppb respectively. With the sensitivity, fast response time, the low-cost and portability exhibited by the system, it shows promising attributes for deployment in the field for humanitarian demining in the future.

Acknowledgements

This project has received funding from the European Union's Seventh Framework Programme for research, technological development and demonstration under agreement no 284747. IDWS acknowledges a Royal Society Wolfson Research Merit Award. Data supporting this research can be found at <http://dx.doi.org/10.17630/5868c89a-7019-4897-9c54-24ccc551a6e6>.

- [1] O. Leitch, A. Anderson, K.P. Kirkbride, C. Lennard, Biological organisms as volatile compound detectors: A review, *Forensic Science International*, 232(2013) 92-103.
- [2] F. Porritt, M. Shapiro, P. Waggoner, E. Mitchell, T. Thomson, S. Nicklin, et al., Performance decline by search dogs in repetitive tasks, and mitigation strategies, *Applied Animal Behaviour Science*, 166(2015) 112-22.
- [3] M.Y. Rachkov, L. Marques, A.T. De Almeida, Multisensor demining robot, *Autonomous Robots*, 18(2005) 275-91.
- [4] S.M. Ng, D.S.N. Wong, J.H.C. Phung, H.S. Chua, Integrated miniature fluorescent probe to leverage the sensing potential of ZnO quantum dots for the detection of copper (II) ions, *Talanta*, 116(2013) 514-9.
- [5] A. Tonacci, D. Corda, G. Tartarisco, G. Pioggia, C. Domenici, A Smart Sensor System for Detecting Hydrocarbon Volatile Organic Compounds in Sea Water, *Clean-Soil Air Water*, 43(2015) 147-52.
- [6] Y. Wang, B.R. Rae, R.K. Henderson, Z. Gong, J. McKendry, E. Gu, et al., Ultra-portable explosives sensor based on a CMOS fluorescence lifetime analysis micro-system, *Aip Advances*, 1(2011).
- [7] Y. Wang, G.A. Turnbull, I.D.W. Samuel, Conjugated polymer sensors for explosive vapor detection, *Organic Semiconductors in Sensors and Bioelectronics Iv*, 8118(2011).
- [8] Y. Wang, Y. Yang, G.A. Turnbull, I.D.W. Samuel, Explosive Sensing Using Polymer Lasers, *Molecular Crystals and Liquid Crystals*, 554(2012) 103-10.
- [9] Y. Yang, G.A. Turnbull, I.D.W. Samuel, Sensitive Explosive Vapor Detection with Polyfluorene Lasers, *Advanced Functional Materials*, 20(2010) 2093-7.
- [10] A. Rose, Z.G. Zhu, C.F. Madigan, T.M. Swager, V. Bulovic, Sensitivity gains in chemosensing by lasing action in organic polymers, *Nature*, 434(2005) 876-9.
- [11] J.S. Yang, T.M. Swager, Porous shape persistent fluorescent polymer films: An approach to TNT sensory materials, *Journal of the American Chemical Society*, 120(1998) 5321-2.
- [12] R.N. Gillanders, P.O. Morawska, T.H. Nguyen, F. Chen, I.A. Campbell, I.D.W. Samuel, et al., Development of polymer-based sensor systems for explosive vapour detection, *Mine Action 2015, Biograd, Croatia, 2015*, pp. 201-4.
- [13] S. Gambino, A.K. Bansal, I.D.W. Samuel, Photophysical and charge-transporting properties of the copolymer SuperYellow, *Organic Electronics*, 14(2013) 1980-7.
- [14] K. Gilissen, J. Stryckers, P. Verstappen, J. Drijkoningen, G.H.L. Heintges, L. Lutsen, et al., Ultrasonic spray coating as deposition technique for the light-emitting layer in polymer LEDs, *Organic Electronics*, 20(2015) 31-5.

- [15] N.C. Greenham, I.D.W. Samuel, G.R. Hayes, R.T. Phillips, Y. Kessener, S.C. Moratti, et al., MEASUREMENT OF ABSOLUTE PHOTOLUMINESCENCE QUANTUM EFFICIENCIES IN CONJUGATED POLYMERS, *Chemical Physics Letters*, 241(1995) 89-96.
- [16] D. Bondarev, O. Trhlikova, J. Sedlacek, J. Vohlidal, Stability of MEH-PPV: Poly{ 2-methoxy-5-(2-ethylhexyloxy)-1,4-phenylene vinylene} in solutions exposed to air in the dark and at daylight at laboratory temperature, *Polymer Degradation and Stability*, 110(2014) 129-36.
- [17] A. Rivaton, A. Tournebize, J. Gaume, P.-O. Bussiere, J.-L. Gardette, S. Therias, Photostability of organic materials used in polymer solar cells, *Polymer International*, 63(2014) 1335-45.
- [18] R.G. Ewing, M.J. Waltman, D.A. Atkinson, J.W. Grate, P.J. Hotchkiss, The vapor pressures of explosives, *Trac-Trends in Analytical Chemistry*, 42(2013) 35-48.

Vitae

Ross N. Gillanders is a Research Fellow within the Organic Semiconductor Centre at the School of Physics & Astronomy at the University of St Andrews. He was awarded a BSc(Hons) in Instrumentation with Applied Physics from Glasgow Caledonian University in 2001, and completed his PhD in Physical Chemistry in 2004 at Strathclyde University, Glasgow. He moved to the Optical Sensors Laboratory in Dublin City University in late 2005 to work on an optical oxygen sensor for marine and estuarine applications. He subsequently worked in University College Cork developing novel polymeric optical oxygen sensors for food packaging. Prior to taking the role at St Andrews, he worked as a Research Engineer at Cork Institute of Technology, mainly developing instrumentation for industry-led water-related projects. His current research interests include explosive detection, sensor materials and optical instrumentation.

Ifor D.W. Samuel is a Professor of Physics and the Director of the Organic Semiconductor Centre at the School of Physics & Astronomy at the University of St Andrews. He studied for both his MA and

PhD in Physics at Cambridge. After finishing his PhD he moved to Paris and worked with France Telecom for two years, investigating the non linear optical properties of organic materials. Then he returned to Cambridge for a year, received a Royal Society University Research Fellowship and took up a position at the University of Durham until August 2000 when he moved to St Andrews. In 2001 he started the Organic Semiconductor Centre to encourage collaboration between physicists and chemists in developing the next generation of organic semiconductors and the wider field of organic electronics.

Graham A. Turnbull is a professor of physics at the School of Physics & Astronomy at the University of St Andrews. He graduated from the University of St Andrews with an MSci degree in physics in 1995 and a Ph.D. in 1999. From 2002 to 2007 he held an EPSRC Advanced Research Fellowship for research into advanced solid-state polymer laser systems, and has been a faculty member in St Andrews since 2003. His current research interests focus on photonic applications of soft materials, including organic semiconductors, chemical sensing, and nanophotonics.

Fig. 1. Chemical structure of Merck Super Yellow, with $x:y:z = 1:12:12$

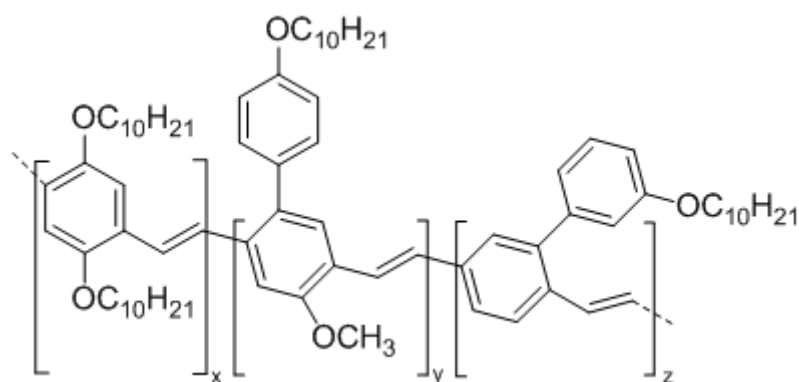
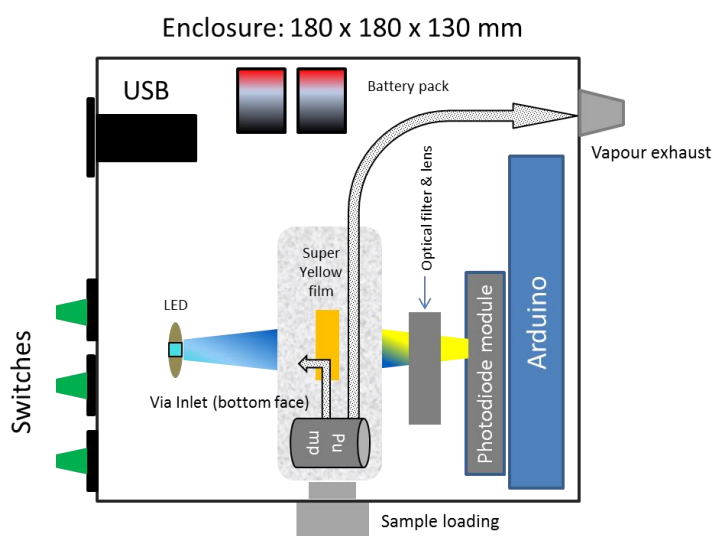
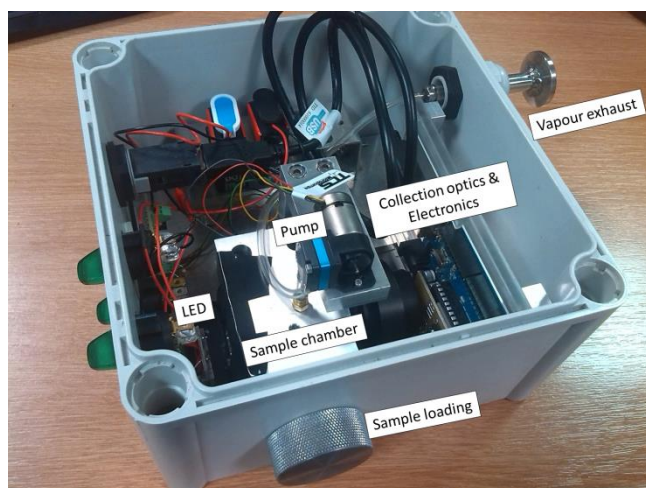

Fig. 2. (a) Schematic of instrumentation (not to scale); (b) Photograph of Enclosure with labelled parts; (c) Loading mechanism with a Merck Super Yellow film.



A



B



C

Fig. 3. Low-power transimpedance circuit for photodiode

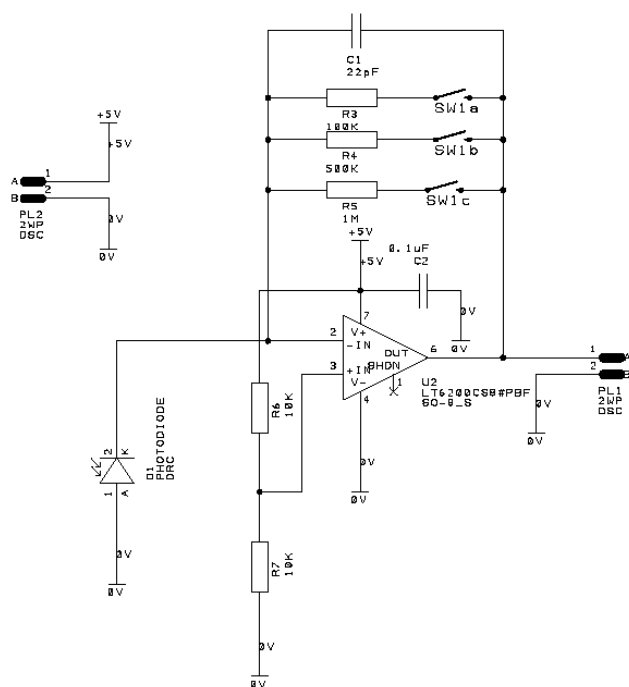

Fig. 4. LabView-based GUI of the optical sensing system.

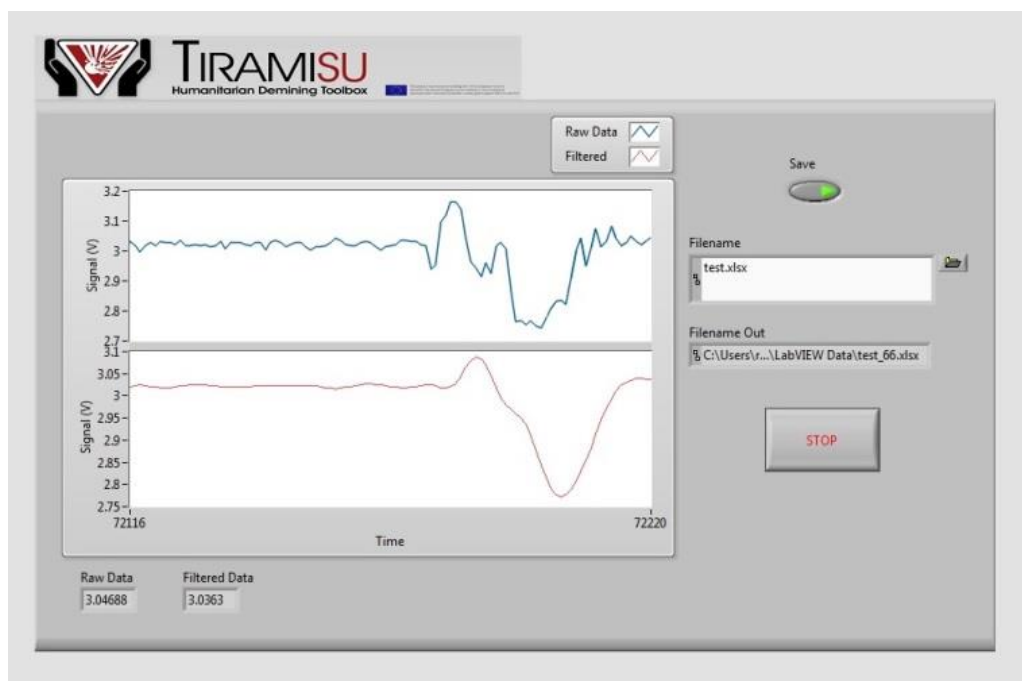

Fig. 5. Absorption and emission spectra of Merck Super Yellow films spin-coated onto a glass coverslip.

Emission spectrum recorded with $\lambda_{ex} = 440$ nm.

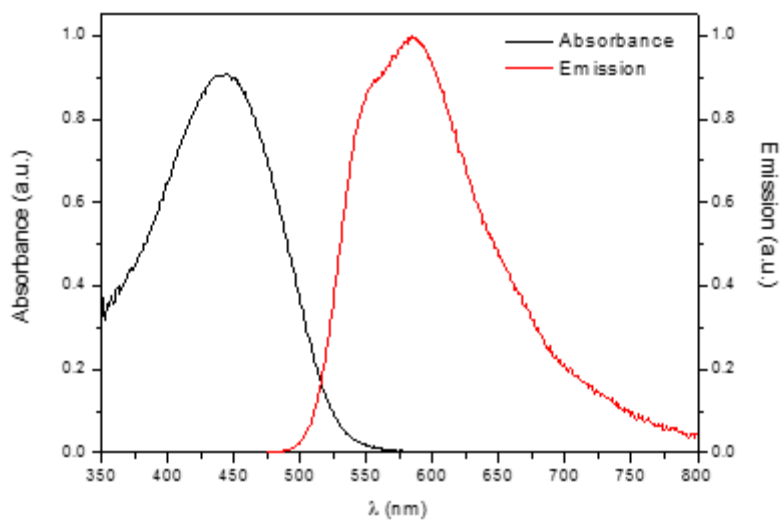

Fig. 6. Response of system to 2,4-DNT vapour delivered via nitrogen line (Black line) with clean nitrogen control line (red). The normalised signal response shows the drop in measured fluorescence from the film with time.

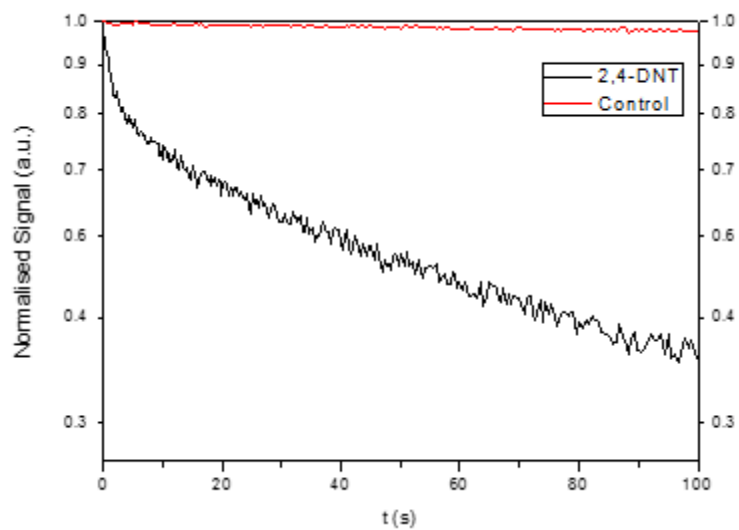

Fig. 7. Response of Super Yellow films to 2,4-DNT buried in a plastic casing at a depth of 2 cm in soil (black and red lines), and in sand (purple line) against blank sample (blue line).

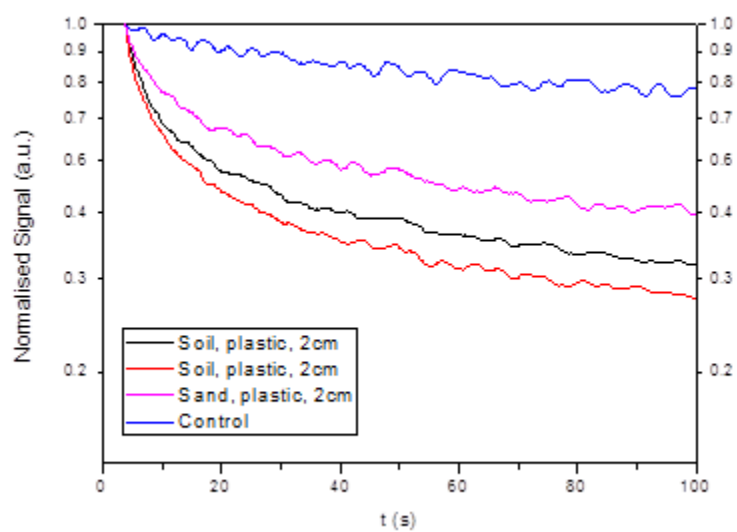

Fig. 8. Comparison of Super Yellow films with 2,4-DNT (black and red lines) and TNT (green line) against blank (blue line), with the explosives buried at 2cm under soil in plastic.

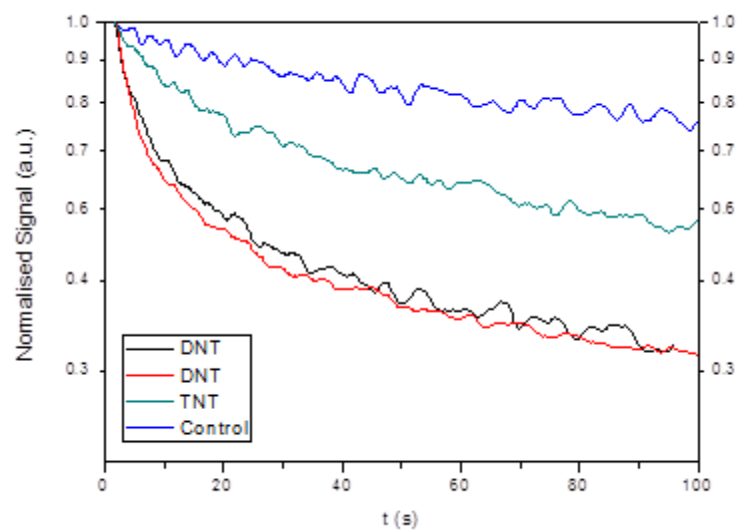

Table 1 – Attributes of sensor responses in Figure 8

Nitroaromatic	Material	Media	Depth	QE (%) at 100 s	Slope at 10 s (s⁻¹)
DNT	Plastic	Soil	2 cm	65	0.035
DNT	Plastic	Soil	2 cm	65	0.039
TNT	Plastic	Soil	2 cm	42	0.018
Control	Plastic	Soil	2 cm	21	0.006

Table 2 – Matrix of simulated buried landmines and corresponding sensing attributes

Nitroaromatic	Material	Media	Depth	QE (%) at 100 s	Slope at 10s (s⁻¹)
DNT	Plastic	Sand	5 cm	68	0.048
DNT	Metal	Sand	2 cm	67	0.053
DNT	Plastic	Soil	10 cm	74	0.047
DNT	Metal	Sand	10 cm	72	0.05
TNT	Plastic	Sand	2 cm	69	0.049
TNT	Metal	Soil	5 cm	73	0.048
TNT	Plastic	Soil	5 cm	71	0.04
TNT	Plastic	Sand	10 cm	70	0.049
TNT	Metal	Sand	10 cm	74	0.051
TNT	Metal	Sand	5 cm	76	0.042
DNT	Metal	Soil	5 cm	74	0.042