

## TOOLS FOR THE HIGH PENETRATION OF PV SYSTEMS IN THE EU ELECTRICAL NETWORKS: RESULTS OF PVCROPS PROJECT

L. Narvarte(\*)<sup>1</sup>, L. Marroyo<sup>2</sup>, M. Collares<sup>3</sup>, N. Tyutyundzhiev<sup>4</sup>, M. Conlon<sup>5</sup>, N. Bouzzan<sup>6</sup>, E. Guelbenzu<sup>7</sup>, R. González<sup>8</sup>,  
A. Desportes<sup>9</sup>, G. Simmonds<sup>10</sup>, B. Wilkin<sup>11</sup>

1- Instituto de Energía Solar. Universidad Politécnica de Madrid (IES-UPM), ETSIS Telecomunicación, Campus Sur  
UPM. Ctra. de Valencia km7, 28031 Madrid, Spain

(\*)navarte@ies-def.upm.es

2- Universidad Pública de Navarra, Campus Arrosadia, 31006 Pamplona, Spain.

3- University of Évora, Largo dos Colegiais 2, Evora, Portugal

4- Central Laboratory of Solar Energy and New Energy Sources, 72 Tzarigradsko chausse Blvd. Sofia, Bulgaria

5- Dublin Institute of Technology, Rathmines Road Lower 143, Dublin, Ireland

6- Office Natinal de l'Electricité, Rue Othman ben Affan 65, Casablanca, Morocco

7- Acciona Energía, Av. Ciudad de la Innovación 5, Sarriguren, Spain

8- Ingeteam Power Technology, Parque Tecnológico de Bizkaia Edif 106, Zamudio, Spain.

9- Rtone, Rue Saint-Cyr, 120, Lyon, France

10- Renewable Energy Dynamics Technology, Clontarf Road 44, Dublin, Ireland

11- Apere, Rue Royale 35, Brussels, Belgium

**ABSTRACT:** The Solar Energy Industrial Initiative established the objective of integrating PV into the grid to provide up to 12% of the EU electricity demand. The FP7 project PVCROPS has developed solutions to allow the high penetration of PV systems in EU electrical networks and to reduce its Levelized Cost (LCoE) increasing PV system performance. The solutions consist of documents like technical specifications and toolboxes for design, prediction, integration of batteries and automatic detection of performance failures. Six of them are on-line free tools and thirteen are marketable products. These tools allow reducing the LCoE up to 30%, increasing the Performance Ratio up to 9% and PV penetration of 30%. The tools developed by PVCROPS are detailed in [www.pvcrops.eu](http://www.pvcrops.eu)  
**Keywords:** Battery Storage and Control, Building Integrated PV (BIPV), Cost reduction, Energy Performance, Grid Integration, Modelling, Qualification and Testing.

### 1 INTRODUCTION: GRID INTEGRATION AND REDUCTION OF LEVELIZED COST OF PV ENERGY

One of the main objectives of the Solar Energy Industrial Initiative (SEII), through its "*Paradigm Shift Scenario*", is to "*enhance the integration of PV generation into the grid and demonstrate that PV could provide up to 12% of the EU electricity demand by 2020*". This means percentages of up to 30% in Southern European countries that enjoy a higher solar radiation. SEII states that "*as PV market share grows, concern about potential impacts on the stability and operation of the electricity grid may create barriers to future expansion*". A high PV penetration requires the conditions to be established that allow massive integration of distributed sources of PV generation within the EU electrical system, not only acting on the grid side but also on the PV systems side. This involves the implementation of:

- technical solutions to avoid disturbances induced by the PV power fluctuations into the grid,
- and still beyond, the possibility for PV systems to assist the grid management when the Distribution System Operator (DSO) or the Transmission System Operator (TSO) ask for it.

The achievement of the *Paradigm Shift* will lead to a transformation of PV generation from being a major concern for DSOs and TSOs, to being an additional collaborator to the grid management. The integration of the following two main routes will lead to a higher integration of PV into the grid:

- energy management and storage control in PV systems,
- and the prediction and mitigation of PV power

fluctuations.

The high penetration of PV systems into the EU electrical networks is also related with another Key Performance Indicator established by the SEII which is the reduction of the Levelized Cost of Energy (LCoE) of PV generation. The reduction in the initial cost of the PV systems is the most direct and intuitive pathway to decrease the LCoE. At the system level, this means extra design optimization and a higher performance. Current PV systems have Performance Ratios (PR) ranging from 50% to 90%[1,2,3,4,5,6]. This represents a wide range of performances, thus suggesting that the potential for improvement is substantial. Lower values of PR have been related to:

- deficient design;
- lack of technical specifications for PV system as a whole;
- inefficient in-the-field quality control procedures;
- and lack of appropriate Operation & Maintenance procedures to detect performance failures.

PVCROPS has developed tools for both, high penetration of PV systems in the EU electrical network, and reduction of the LCoE. These tools are related with four main research fields:

- Robust modelling, advanced simulation, design optimization, technical specifications and quality control procedures;
- Prediction of PV production and PV power fluctuations;
- Integration of energy management and storage strategies for PV plants and BIPV;
- Monitoring, real-time follow-up and advanced diagnosis of performance.

This paper presents the final results of PVCROPS project in terms of the tools that have been developed and their impact in the European solar industry..

## 2 RESULTS OF PVCROPS PROJECT

2.1 Advanced design and simulation tool “SISIFO” together with linked Technical specifications and quality control procedures for contractual frameworks

Large grid-connected PV plants have become an interesting financial product all around the world. So, as for any financial product, a key point is to ensure that profitability of the PV installation is high and its risk of failure is low: the higher the yearly energy production and the lower its uncertainty, the more attractive is the project. Furthermore, low uncertainty means higher bankability as financing is not related with  $P_{50}$  of PV production expectancy but with  $P_{90}$ .

Nevertheless, most of the commercial software for energy yield forecast and technical specifications to check the quality of the installation do not take into account the bankability of a PV installation: they treat PV systems only from the technical point of view and they do not establish proper links between the technical and the financial issues. It is necessary to simulate the energy yield taking as inputs just parameters guaranteed by the manufacturers in order to assign responsibilities in case of not-fulfillments of the contractual commitments. Moreover, it is required quality control procedures that determine who is the responsible when there is a system operation below the expected one.

To respond to this need, PVCROPS has developed:

- An open-source design and simulation tool called SISIFO ([www.sisifo.info](http://www.sisifo.info)) that requires as input just information guaranteed by the PV component manufacturers, in order to link its results with the technical specifications and quality control procedures in contractual frameworks.
- Technical specifications and quality control procedures that can be applied in the context of Project Finance schemes and that can assign responsibilities in case of under-performance.
- A manual of good practices to foster technical quality of PV systems from the design till the operation and available in nine different languages..

### 2.2 Toolboxes for the prediction of PV systems production and PV power fluctuations

In order to characterize PV power fluctuations, data every second have been recorded from 2008 in several PV plants totalizing 20 MWp and ranging from 48 kWp to 9.5MWp, separated by distances ranging from 6 km to 60 km. Power output 1s data are obtained at the point of common coupling by means of a power meter, and are recorded by a PLC. Simultaneously, the short circuit current of a reference PV module provide a measurement of in-plane irradiance, which is also recorded. Wind speed (at 2m high), ambient temperature and cell temperature are registered too. Timing is controlled by means of a GPS so that the records from all the sites can be precisely synchronized. Fig. 1 shows the diagram of the data collection system.

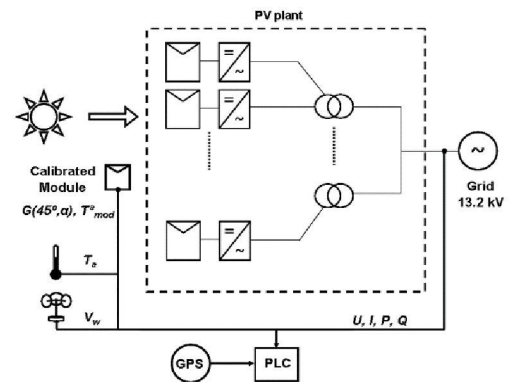

**Figure 1:** Diagram of the synchronized PV power data collection system

Moreover, 5 sec synchronized records of the output power of all the inverters of Moura PV plant, Portugal, are available from 2010. Furthermore, a 14MW PV plant in Bulgaria is being monitored with 1 minute PV power data. This database comprises more than 75 MWp monitored.

This set of data is unique in the world and has allowed characterize PV power fluctuations and analyse the mitigating effect of both, the size of a PV plant and the aggregation of disperse PV plants (Fig. 2).

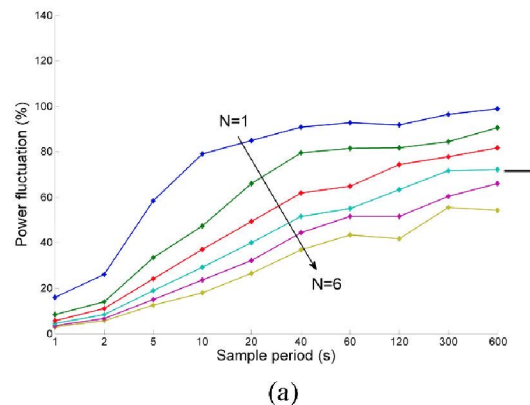

**Figure 2:** Maximum power fluctuations registered during a year at each PV plant for all the possible combinations for  $N = 1 \dots 6$  PV plants.

Based on this, two kinds of prediction toolboxes have been developed: to predict the PV system production and to predict PV power fluctuations. Both give as result the percentiles 10, 50 and 90. And in both cases two approaches have been developed based on parametric (modelling the PV system) and non-parametric methodologies (based just in statistics of the climatologic inputs and the corresponding output power of the PV system). Outstanding results have been achieved: total daily energy production is forecast with an absolute cvMBE\* of less than 1.3%, and, in terms of hourly prediction, the overall cvMAE\* is less than 9.5% (where the prefix cv means that the statistic has been normalized respect to the mean value of all the observations during the same period the statistic was calculated, i.e., one day). These tools are accessible at:

<http://vps156.cesvima.upm.es:3838/predictPac/> .

### 2.3 Toolboxes for sizing batteries in grid-connected PV system according to different energy management strategies

Two toolboxes have been developed to design and size the battery integrated in, respectively, PV plants and BIPV systems. They include several energy management strategies (EMS), including ramp rate control, self-consumption or limitation of grid power.

For example, ramp rate limitation is a technical requirement established by TSOs in several countries. PVCROPS has sized the minimum battery required to fulfil this requirement, based on the characterization of PV power fluctuations. This sizing method has been called “worst fluctuation model” (Fig. 3)

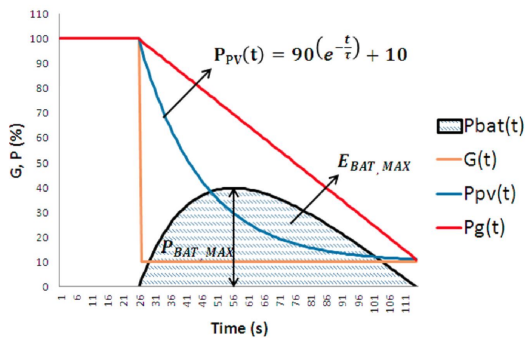

**Figure 3:** Worst fluctuation model. The blue line represents the  $P_{PV}(t)$  response to an irradiance fluctuation (orange line) and the red one is the power injected to the grid  $P_G$  with a ramp-rate control. The difference between  $P_G$  and  $P_{PV}$  is  $P_{BAT}$ , the maximum difference corresponds to  $P_{BAT,MAX}$  and the defined integral of  $P_{BAT}$  corresponds to  $E_{BAT,MAX}$ .

This has been the base for the development of the corresponding energy management strategy whose principle is shown in Fig. 4.

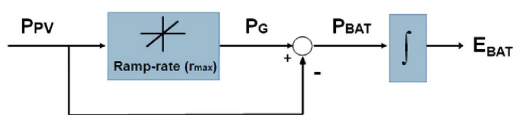

**Figure 4:** Ramp-rate control model for a given  $P_{PV}(t)$  time series. Looking for simplicity, battery and associate electronic converter losses are ignored.

Two demonstrators have been implemented to validate this set of energy management strategies: one with Li-ion battery and one with Vanadium Redox battery (fig. 5 and 6). Different validation tests have been carried out and the validated strategies have constituted the final version of the toolboxes.



**Figure 5:** Vanadium Redox Battery demonstrator



**Figure 6:** Li-ion Battery demonstrator

### 2.4 Tools for the automatic detection and diagnosis of performance failures

Performance Ratio (PR) is the most widely used performance indicator today. However any inaccuracy in solar irradiation data will translate into an incorrect PR calculation. In order to address the shortcomings of existing methods, we have developed a method that is capable of detecting and diagnosing performance failures based solely on the energy production data measured at BIPV installations. This method does not require data relating to BIPV operating conditions, such as solar irradiation. It works by detecting abnormal variations in performance indicators that are characteristic of properly functioning installations. The method makes extensive use of correlations between the energy production of neighbouring and similar PV systems, i.e. peer PV systems, and is therefore called the Performance to Peers (P2P) method. P2P is more stable than PR and thus allow using it as failure detector (fig. 7 and 8). The P2P method has been used, for example, to support the detection and quantification of energy losses resulting from failure causes at 10,000 BIPV systems across Belgium and France.

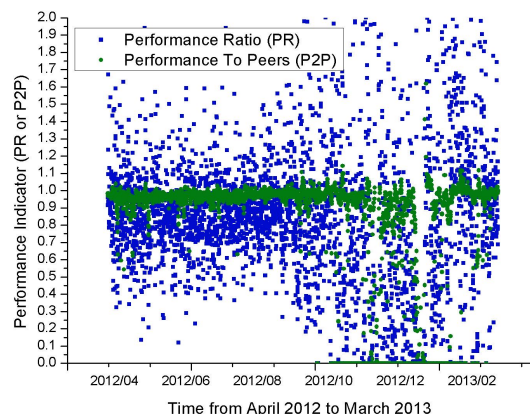

**Figure 7:** Hourly P2P and PR values observed on one particular BIPV system from April 1<sup>st</sup>, 2012 to

March 31<sup>st</sup>, 2013

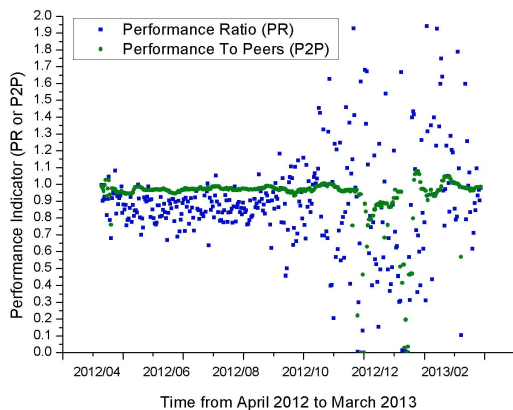

**Figure 8:** Daily P2P and PR values observed on one particular BIPV system from April 1<sup>st</sup>, 2012 to March 31<sup>st</sup>, 2013

### 3 IMPACT

The main Key Performance Indicators (KPIs) of the Solar Europe Industry Initiative have been faced up by PVCROPS. The results and tools achieved by this project allow up to 30% of reduction of the Levelized Cost of Photovoltaic Energy (LCoE), 9% of increase of the Performance Ratio (PR) and a reduction of PV power fluctuations to less than 10% in 10 min allowing PV penetrations in the electrical networks as high as 30%. For example, the estimated reduction of energy losses in BIPV in mid-latitude Europe, and therefore, the increase of the PR, is shown in Fig. 9.

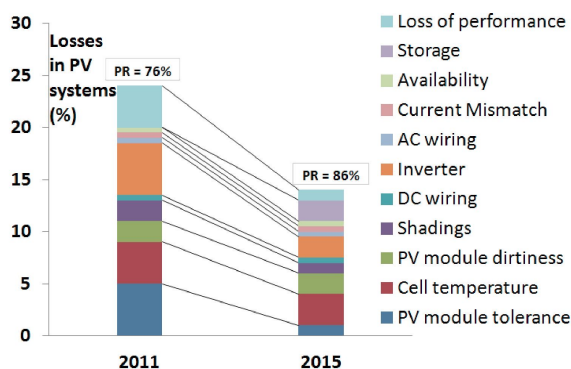

**Figure 9:** Energy losses and PR of BIPV in mid-latitude Europe.

### 4 CONCLUSIONS

PVCROPS has developed tools for both, high penetration of PV systems in the EU electrical network, and reduction of the LCoE. It has produced 6 on-line free to use documents and toolboxes and 13 marketable results that will help the PV industry to reach the objectives of 30% of reduction on the LCoE and PV penetrations in the EU electrical networks as high as 30%.

All of the information about these tools are available at [www.pvcrops.eu](http://www.pvcrops.eu) and cover the key aspects of design,

installation and operation of PV systems: modelling and simulation, technical specifications, quality control procedures, PV power prediction, integration of batteries, energy management, monitoring, automatic detection of performance failures and testing kits.

These tools will allow removing the main technical barriers for the massive integration of PV systems into the grid.

### 4.3 References

References should not appear as footnotes but should be gathered together at the end of the text. When referring to them in the text, type the corresponding reference number in brackets [1]. References should be numbered:

- [1] M. Smith, A. Miller, Proceedings 17<sup>th</sup> European Photovoltaic Solar Energy Conference, Vol. I (2002) 903.
- [2] K.W. Boer, Solar Cells 16 (1996) 591.

### 5 ACKNOWLEDGEMENTS

This work has been partially supported by European Commission within the project PV CROPS (Photovoltaic Cost rÉduction, Reliability, Operational performance, Prediction and Simulation) under the 7th Framework Program (Grant Agreement no. 308468).

### 6 REFERENCES

- [1] U. Jahn et al, Operational performance of grid-connected PV systems on buildings in Germany, Progress in Photovoltaics 12-6 (2004) 441.
- [2] J. Leloux et al, Performance analysis of 10,000 residential PV systems in France and Belgium, 26th PVSEC, 2011.
- [3] [www.BDPV.fr](http://www.BDPV.fr)
- [4] J. Leloux et al., Review of the performance of residential PV in France, Renewable and Sustainable Energy Reviews 16-2 (2012) 1369.
- [5] J. Leloux et al., Review of the performance of residential PV in Belgium, Renewable and Sustainable Energy Reviews 16-1 (2012) 178.
- [6] F. Martinez-Moreno et al, On the testing of large PV arrays, Progress in Photovoltaics 20-1 (2012) 100.