

Proposal for a Wavelength Multiplexed Quantum Metropolitan Area Network

View metadata, citation and similar papers at core.ac.uk

brought to you by  CORE

Research Group on Quantum Information and Computation, Universidad Politécnica de Madrid, Spain

² Group of Applied Physics, Université de Genève, Switzerland

³ Optical Quantum Technology, Austrian Institute of Technology, Austria

provided by Servicio de Coordinación de Bibliotecas de la Universidad Politécnica de Madrid



Quantum Key Distribution (QKD) is maturing quickly. However, the current approaches to its network use require conditions that make it an expensive technology. All the QKD networks deployed to date are designed as a collection of dedicated point-to-point links that use the trusted repeater paradigm. Instead, we propose a novel network model in which QKD systems use simultaneously quantum and conventional signals that are wavelength multiplexed over a common communication infrastructure. Signals are transmitted end-to-end within a metropolitan area using optical components. The model resembles a commercial telecom network and takes advantage of existing components, thus allowing for a cost-effective and reliable deployment.

Network Design

The design is an optical metropolitan area network [1] where quantum and conventional signals are wavelength multiplexed (WDM). QKD systems are located at the final users and any device capable of disrupting the quantum signals has been removed. Therefore, QKD systems are connected via direct optical paths. The network is divided into backbone (core) and access networks.

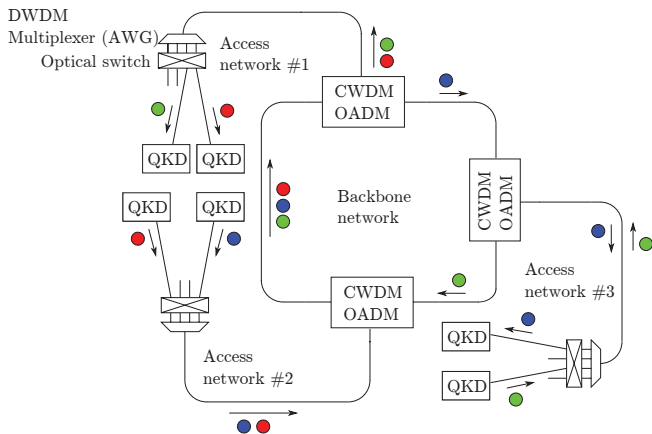

Backbone network

- Ring topology.
- Traffic between access networks.
- Coarse WDM technology (CWDM).
- Optical Add-Drop Multiplexers (OADM) route one or more CWDM channels to each access network.

Access network

- Star topology.
- Traffic between QKD systems and the backbone network.
- Dense WDM technology (DWDM).
- Arrayed Waveguide Grating multiplexers (AWG) route the DWDM channels to the QKD systems.
- (Optional) Switches before the AWG to use any port.

Channel Grid

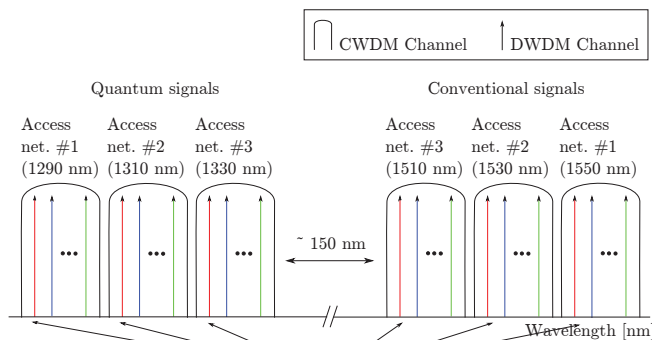

- CWDM channels located at the O band are used for quantum signals, and at the C band for conventional ones. A pair of them is assigned to each access network, which will be dropped by the OADM. However, OADMs should add any channel in order to allow communications with any access network.
- The spectrum separation isolates the quantum signals from the noise of conventional signals [2].
- Within the access network, an AWG demultiplexes a CWDM channel into DWDM channels and assigns them to the QKD systems.
- Although two CWDM channels are used per access network, only one AWG is required because of its cyclic behaviour: periodic DWDM channels are output through the same port. Therefore, a pair of quantum and conventional DWDM channels is assigned to each QKD system.

Operating mode

Based on the described network model and WDM grid, the network works under the wavelength-addressing paradigm: a QKD emitter can communicate with a QKD receiver by emitting at its assigned channels. However, the network is limited to a fixed communication scheme where QKD systems can only communicate with the ones connected to the same port of the AWG (periodical ones). If a more flexible, dynamic scheme is required, switches can be used before the AWG in order to connect the QKD emitter to the appropriate port of the AWG and thus be able to communicate with any QKD receiver.

The scheme is non-blocking since communications in both directions can be performed simultaneously between different access networks. This is illustrated in the network figure using colored dots to represent the communications.

Test-bed

A test-bed of the proposed network has been deployed using 100 GHz 32-channels AWGs and self-made CWDM OADMs. The longest optical path (16 km) is between access network #2 and access network #3, and it has a loss budget of 23 dB.

After successfully checking its operation, measurements were done to characterize the noise contribution of the conventional signals. For this task, the longest path was used: a powerful emitter at the access network #2 and a single-photon detector (SPD) at the access network #3 (forward noise) and #2 (backward noise).

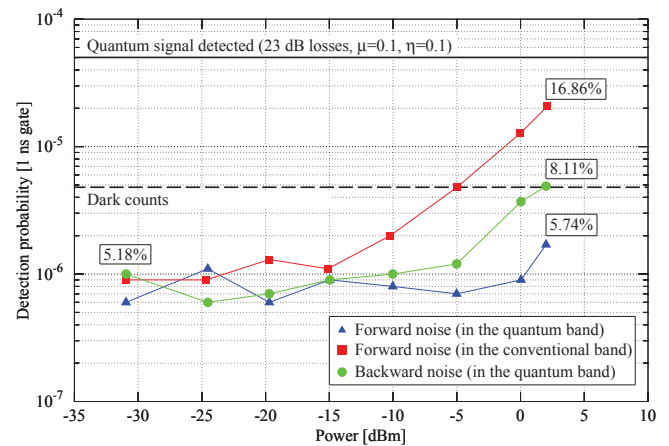

Experimental results

The figure shows the noise detection probability per 1 ns gate at the SPD over the total power emitted, an estimated quantum signal and the own noise of a SPD [3]. Using these parameters, we calculate the QBER for significant points of the curves (white boxes).

- The noise is indeed reduced with the spectrum separation (red curve vs blue curve).
- The backward noise is higher due to the losses of the scenario. However, it can be solved using filters at the access network and isolators at the OADMs.
- In this test-bed, based on the QBER, a total of $\approx +2$ dBm power is allowed. This is enough for 32 conventional channels at -13 dBm of 1 Gbps rate [4].

Acknowledgments

UPM acknowledges financial support by projects *Quantum Information Technologies Madrid*, QUITEMAD (P2009/ESP-1594), *Comunidad Autónoma de Madrid*, and *Quantum Hybrid Networks* (TEC2012-35673), *Ministerio de Economía y Competitividad*, Spain. GAP acknowledges financial support from NCCR-QSIT. AIT acknowledges financial support by the project *QKD-Telco: Practical Quantum Key Distribution over Telecom Infrastructures* (contract No. 835926), within the FIT-IT programme funded by the *Austrian Federal Ministry for Transport, Innovation and Technology* (BMVIT) in coordination with the *Austrian Research Promotion Agency* (FFG).

References

- [1] R. Ramaswami, K. Sivarajan, and G. Sasaki, *Optical Networks: A Practical Perspective*, 3rd Edition, 3rd ed. Morgan Kaufmann Publishers Inc., 2009.
- [2] N. A. Peters et al., "Dense wavelength multiplexing of 1550 nm QKD with strong classical channels in reconfigurable networking environments," *New J. Phys.*, vol. 11, no. 4, p. 045012, 2009.
- [3] H. Zhang et al., "2.23 GHz gating InGaAs/InP single-photon avalanche diode for quantum key distribution," in *Proc. SPIE*, vol. 7681, 2010, pp. 76810Z-76810Z-8.
- [4] K. A. Patel et al., "Coexistence of High-Bit-Rate Quantum Key Distribution and Data on Optical Fiber," *Phys. Rev. X*, vol. 2, no. 4, p. 041010, 2012.