

Pablo Bris

Professor, Technical University, Madrid

Felix Bendito

Associate Professor, Technical University, Madrid

Silvia Nuere

Professor, Technical University, Madrid

Muriel Saint-Supéry

PhD Student, University Jaume I, Castellón

Houses built from accommodating cabins

The current economic crisis has meant, particularly in Spain, the almost cessation of new buildings construction. This deep crisis will mean in future an irreversible change in the Spanish construction model, based to date almost exclusively on the brick.

After focusing on the Spanish property boom and examining its impact on the concept of housing (in a few years the house has moved forward from being contemplated exclusively as a primary good to be also considered a capital asset), we analyse the influence that this transformation has had on architecture (housing typology, building methods, the architectural profession and the architect training) and offers architectural alternatives –through the university– to the present crisis.

The project “Houses built from accommodating cabins” is part of a larger research within the line “Modular Architecture” developed by the Research Group “Design and Industrial Production”, belonging to the Technical University of Madrid, which aims to respond to the need for decent housing at an affordable price, by offering through Internet the plans, resources and other technical details required to build a house oneself.

The proposed houses are built from the combination of industrially made modules (accommodation cabins, which are prefabricated modules usually used as provisional constructions in conventional building works), prefabricated subsystems and other catalogue components available on the market, all they set together by dry joints.

Keywords: Recycling, affordable housing, prefabricated, self-construction, crisis.

Introduction

The current economic crisis in Europe has implied, in the specific case of Spain, the almost complete cessation of new buildings construction.

Naredo (2010) analyses the Spanish real state model’s genesis, its consolidation and boom, and the consequences this model has generated from urban, territorial, economic, ecological and social viewpoints.

This article focuses on the Spanish property boom and examines its impact on the concept of housing. In a few years the house has moved forward from

being contemplated exclusively as a primary good to be also considered a capital asset. We analyse the influence that this transformation has had on architecture (housing typology, building methods, the architectural profession and the architect training) and offers architectural alternatives –through the university– to the present crisis.

Housing: from primary good to capital asset

The Spanish real state model has changed, in just 60 years, from the absolute prevalence of housing rental to the predominance of home ownership (Rodríguez López, 1999; CECODHAS, 2006; Ayuso & Restoy, 2003, 2006; Alfaro & Andrés, 2007; and Inurrieta, 2007) to the extent that, while in the middle of the 20th century the percentage of home ownership in Madrid and Barcelona was of 6 and 5% respectively (Naredo, 2004), nowadays it amounts to 83.2%, what makes Spain be one of the European Community countries with the highest percentage of home ownership (UN, 2012).

This situation has come about due to a series of political initiatives (undertaken in connivance with the economic power) such as: the promotion of home ownership as direct investment, disincentive measures for house renting and a minimal investment in social housing (Inurrieta, 2007), which have caused the burst of two real estate bubbles, one after the other.

The importance of the real state sector in the Spanish economy increased after the accession of the country to the European Economic Community, when the industrial and agricultural sectors were dismantled and construction become a true industry (Naredo, 2004). Under the three events of 1992: Olympics in Barcelona, Universal Exposition in Seville and designation of Madrid as European Capital of Culture of that year, a first housing bubble (1986-1992) - of a speculative rather than constructive nature¹- evolved. From the beginning of this bubble onward, housing prices, which had been growing at rates comparable to consumer prices until then, began to grow in parallel with stock prices and property starts being seen from two perspectives: Firstly, as a necessary good, recognized as a legal right by Article 47 of the Spanish Constitution. Secondly, as a capital asset in its different aspects: 1) a generator of wealth thanks to an ever-increasing real estate capital gains, until 2007; 2) a store of value in the medium and long term; or 3) a short-term speculative product (purchase and sale on periods shorter than two years²); what caused an increase in housing demand.

On account of this growing demand –promoted again by political-economic power– and cheap and plentiful financing, the second housing bubble (1997-2007) burst. During this second bubble (of a constructive nature this time³), the concept of home as an investment was maintained and reinforced. Some

¹ In this period, the housing prices soared (IMF, 2004 and the Spanish Bank, 2005), but the number of housing built was relatively modest, Bellod (2007) estimates 236.761 on annual average.

² According to data from the Real Estate Registers College, in 2007 one in five homes changed hands before 24 months.

³ From 1999 to 2007, 612.800 houses on annual average were built (Bellod, 2011).

authors studying that speculative behaviour on the real state market in Spain are: Balmaseda et al. (2002); Ayuso & Restoy (2003, 2006); Martinez & Maza (2003); García-Montalbo (2004); and Bellod (2007, 2011).

The fact that housing has become an alternative of investment for many Spaniards -although many others have continued considering it exclusively as a primary good- has resulted in implications not only on their price (and its outsized rise and revaluation⁴), but also, in regards to the new housing building, on its typology, on its building technologies and on the architects and their professional formation.

a) Impacts on housing typology.

Typologically speaking, there is a huge disparity between the limited supply available to users and the growing and changing demand of new homes generated by new lifestyles⁵. In fact, could be considered an euphemism to bring up “limited supply” because there is only one type of housing (hall, living room and kitchen, hallway that leads to 1, 2 or 3 bedrooms and 1 or 2 bathrooms) and the only variations are therefore quantitative, both in number of bathrooms and bedrooms and in square meters.

The demand, although difficult to define, requires different, variable and flexible responses. It seems unreasonable to ignore the evolution experienced by the family in recent years (one-parent and blended families, single people, etc.) or the population aging. Although Spain shares all these changes in demand with occidental countries, consequent changes in typologies developed in these countries (Schneider and Hill, 2007 and Friedman, 2001 and 2002) have no equivalent in Spain.

From our point of view, the fact that the housing supply in Spain remains monolithic is directly related to the widespread consideration of housing as a capital rather than a primary good (the more homogeneous the homes, the greater the probability of being exchanged in the market). This fact makes the price of the meter square be considered the most important feature of a house instead of its quality in terms of typology -which was just discussed- and from the constructive point of view.

b) Impacts on building methods.

In Spain the same building model from the 60s remains. The construction is on site and follows always the same sequence of procedures: first, foundation and linear structure (beams and columns, usually made of concrete); then, roofing, building enclosure, interior walls and service systems. It is a construction model that uses brick, concrete, cement and plaster as main materials, and requires long work deadlines. It is based on the successive entrance of various trades on site what implies that its success depend on the ability and training of the various professionals.

Apart from some technological problems due to incorrect arrangement of the enclosure layers, this system worked well until the first Spanish real estate

⁴ Between 1997 and 2004, the overall housing price raises 149% in Spain (UN, 2012).

⁵ Some relevant works on the tenure patterns and housing demand in different geographical areas are: Lee and Trost (1978); Rosen (1979); King (1980); Jaén and Molina (1994); Ermisch et al. (1996); Colom and Molés (1998 and 2004); Colom et al. (2002) and Naredo (2004).

bubble (1986–1992). From then onward, the slight rise in the number of housing built and the increase of the housing demand this boom implied was enough to demolish the ancient craft guilds-based system since there were not enough professionals to absorb it⁶. During the second housing bubble, the brutal increase of the housing stock intensified this problem. Paradoxically, at the same time, the quality of building materials was improved and there was a great development in the several buildings subsystems (modular systems, carpentry, façade systems, interior partitions, improvement and development of service systems, etc.). The combination of these pre-manufactured subsystems with the artisanal constructive model is regrettable.

c) Impacts on the architectural profession.

Most of the modern architecture historiography (Panoyotis, 2001) has presented a heroic image of the architect: an independent professional with clear social conscience, who serves their fellow citizens and is able to transform the society in which he lives. Under this point of view, architects would have a mediation role between private enterprise (developers and building contractors) and the citizens (future users of these homes). Therefore, the architect's utopian goal would be to defend the end-user's interests against the interests of his actual customer, the developer and sponsor. Also, the common sense determinate that the architects have a direct commitment to their work, regardless of the user, the developer and even against the building contractor's demands, not only from an aesthetic viewpoint, but also in connection to precision and quality of the building.

This utopian vision of the profession has long been in crisis. In Spain, the architects have been unable to counter the voracity of the building developers, to promote new typologies of housing or even to suggest alternative methods to the traditional craft-based construction. This reflection is not intended to be critical since the architects had no option to serve the counterweight to the converging interests of economic and political power. However, they have their share of the responsibility in the constructive madness experienced in Spain as they have been serving the market –not users– and have been unable to reverse or ease the situation.

d) Impacts on architect training.

The training of architects in Spain has not substantially changed in the last 100 years. Unlike what happens in other European countries, the Spanish architectural education has an integral character including both aesthetic and technical training (structures and service systems calculating). However, in the present construction model the aesthetics aspect is a priority since the building is designed almost exclusively from the formal viewpoint and technical and structural problems are solved afterward. The idea conveyed by the University to the working world is that the architect leads a pyramidal hierarchical design method where first requirement is formal and the other professionals, usually engineers, have to adapt their structures and service system to the aesthetic-formal design of the building. This approach to architecture taught on Spanish

⁶ To illustrate the situation, is pointed out that since those years, in Madrid, a city with great tradition on brick façades, it is unusual to find a properly executed façade.

universities is in absolute harmony with the traditional building method, where the structures and building facilities tend to hide behind the architectural spaces.

Industrial architecture and prefabrication has been absolutely neglected in the Spanish universities. It has been transferred by the architects to the civil engineers on a voluntary basis, what partly explains the lack of development and research on alternative constructive methods on architecture.

The crisis: time to change our real estate model.

The Spanish real state crisis affects principally those whom bought their homes as a personal good, without speculative intentions (motivated, in many cases, by the high prices of rent, which are equal or even bigger than the monthly mortgage fees), but paid a price inflated by the speculative bubble. Together with this fact, the dramatic rise of unemployment is causing that a growing number of Spaniards are being evicted⁷ and, therefore, put at risk of social exclusion.

There aren't solutions for all these families from the central administrations. In Spain, as in other Mediterranean countries, family help offsets institutional inaction: whole families return to live in their relative's houses, in many cases with no other income than their parents' pensions. Paradoxically, and despite the housing problems faced by a growing number of Spaniards, according to the the Spanish National Institute for Statistics (INE), in December 2012 there were 3.4 million empty homes.

The solution to this serious problem should go through reuse and rehabilitation of the oversized Spanish housing stock, since there is no point in trying to reactivate the construction sector, with the same real state model that has led to this critical condition. However, the alternatives the Spanish government operates are far from transforming part of the current houses surplus into social housing (Inurrueta, 2007) or from promoting rental market.

Therefore, it is time for Universities to offer solutions for the current housing problem, to the extent of our possibilities.

Proposed solutions: ends and means.

The project herein presented –"Family houses from accommodation cabins"– is part of the work of the Research Line "Modular architecture", part of the research group "Industrial Design and Manufacturing" from the Polytechnic University of Madrid.

The "Modular architecture" Research Line's general aim is to propose industrialized or highly prefabricated housing alternatives, which will simplify the citizens' access to adequate housing, from architectural and also constructive standpoints – considering space, typology, aesthetic, among other criteria, but also constructive quality, energetic efficiency, durability, etc.

⁷ Since the start of the crisis there have been more than 350.000 eviction (Colau & Alemany, 2012).

Prefabrication seems to be an alternative⁸ that, from a logical point of view, should have been developed in house building, as in other countries (Davies, 2005; Kieran & Timberlake, 2004; Ryan, 2010). The improve of construction quality, the decrease of run times, the increase of safety in the workplace, etc., would justify that a relevant part of housing construction were performed under this alternative system.

The alternatives or solutions proposed from our research group share the following points:

- a) The development of research on architectural typologies;
- b) The abandonment of conventional craft-based building system and the gradually replacement by industrialized construction methods and/or highly prefabricated systems and subsystems assemblies, together with the enhancement of the reuse of existing buildings.
- c) The rethinking of the way projects are conceived and the replacing the hierarchical and pyramidal system –in which architects occupy a top position and aims the formalism– by a matrix arrangement, in which they are part of a team of technicians and engineers –with the important mediation role between the different professionals– and whose main objective is to build/produce a building that simultaneously fulfil aesthetic, technical, energetic, environmental and constructive exigencies.
- d) The provision of solutions from a social viewpoint. Not with the intention of recovering the architect's heroic vision disseminated by the Modernism Movement, but considering the idea of architecture able to satisfy people's needs and not exclusively working to private initiative.
- e) The incorporation of research to professional practice. With the traditional construction system, every project starts from zero. Experience is gained through the building execution, but there is no possibility of a cumulative knowledge on projecting or on the applied technologies. Industrialized architecture allows to research with each project and to improve the prefabrication systems, as well as sharing and spreading knowledge.
- f) The rethinking of the way of future architects training. Although the adjustment or rearrangement of the architecture degree courses in Spain exceeds by far our possibilities, we would like to point that if the architecture education in Spain keeps on neglecting training in prefabrication and industrialization, and continues to prioritize the aesthetics over the technique, soon the architecture will not involve architects.

⁸ In Spain, even when there is some rejection of the houses built in an industrialized manner (possibly originated from bad experiences occurred with the heavy industrialization of the 70s), prefabrication has succeed, in the same period, in other areas of the construction industry, for example, in the industrial plant building, in the construction of overhead power lines, or in road construction.

Project Description

The "Family housing from accommodation cabins" is a temporary and somehow emergency project⁹. It does not intend to be a general solution to the housing problems of our country, but aims to be part of a series of alternatives to respond to the presented problems, by the means described in the previous section.

The project's goal is to make available to anyone –and free of charge– the plans, resources and information required for building their own family housing.

The proposed houses are based on the reuse of accommodation cabins (factory-made modules usually used as temporary buildings, offices and restrooms, on the conventional building sites).

The residences must be inexpensive, flexible from the typological point of view (customizable according to the future user's needs), built from the combination of industrially made modules (accommodation cabins), prefabricated subsystems and other catalogue components available on the market, all they set together by dry joints. Furthermore, the houses must be energetic efficient. In conclusion, they must be decent housing, spatially, constructively and, for sure, aesthetically speaking.

The fundamental element of the house is the accommodation cabin. It differs from other components from various points of view. First, it is the only reused component, i.e. the accommodation cabins are second handed, as the other components are new. Second, it is the only three-dimensional and industrial component; the others are prefabricated subsystems or components from catalogues. Third, as long as the prefabricated modules have a fixed standardized size they can determine the possible arrangements of the house, and also force the remaining modulated components to adjust themselves to the building's dimensions.

What is an accommodation cabin?

Accommodation cabins are light prefabricated structures –manipulated by truck crane–, with small dimensions (length: 3, 4, 6, 8m, width: 2.44m, height: 2.59m), which can be transported by truck without special movement permits.

They consist of a solid frame-typed metal structure. The joints between the columns and the beams are rigid, i.e., the house's vertical closure (insulated sandwich panels inside) has no structural function.

a) Advantages of using accommodation cabins as construction basis:

- Ease of obtaining different layouts and typologies from modular elements (see figure 1). The houses are gotten from a variable amount of cabins, depending on the size of the project. It is strongly recommended to use the same type of container in each project. The most common model is the one with 6 meter length. The presented examples are made with this type of cabin. However, it is possible to use any other model. The way the cabins are set

⁹ It would be worth being involve in National Cooperation Programmes and not only in the International ones.

together may vary on the ground plane, but not on height (they are attached by bolted joints at the level of the horizontal beams, at the top and the bottom of the structure).

- Construction quality. The houses are industrially built, with a high level of finishes quality. As mentioned, the structure is frame-typed, which means it is structurally resistant to any alteration made on its façades, as, for example, opening holes on them (see figure 2.1).

This circumstance wouldn't be achieved with the use of other container type, for example, recycled shipping containers – normally reused as basis to other sorts of buildings (Kotnik, 2008). Due to having resistant walls (not beams, or beams that have the façade's dimension) any hole made on its faces implies structural weakening, what limits the size of the holes and occasionally obliges the reinforcement of the perforated wall.

Furthermore, unlike what happens with shipping containers, the accommodation cabins are usually insulated (walls, floor and roof). Although insufficient, the prior isolation is a good base for further improvement (see figure 2.5).

- Economy. Until a few years ago the prices of a shipping container and an accommodation cabin of about the same size (20 feet for the shipping container and a 6 meters for the accommodation cabin) were very similar. Second-handed and in a reasonable condition, coast around 2000 euros. The crisis has changed this balance. The stagnation of the building sector has strongly dropped the accommodation cabins prices: for example, a 6 meter container costs between 300 and 800 euros, depending on possible offers and on its state of conservation. The price of shipping containers remains stable on due the residual value of the steel.

b) Inconveniences of using an accommodation cabin as construction base:

- Aesthetic. The containers' aspect is inevitably associated with its temporary purpose. When used without any modifications, its appearance is usually unsatisfactory.

- Space. The interior space of each module is small, always limited by the width (2.35m on the interior side). Therefore, it is necessary to combine several modules for obtaining larger spaces.

- Thermal and condensation problems. Despite insulated, the frame is a continuous thermal bridge. Furthermore, the frame's metal structure and the roof metal sheet would make the space inhabitable during summer, unless acclimatization systems were installed.

Subsystems incorporated to the accommodation cabin.

To avoid the described problems several construction subsystems are incorporated in the house. The essential ones, both from constructive and aesthetic (external appearance modification) perspectives are two: the addition of a new facade and a new roofing.

There are several reasons for incorporating a new building enclosure. First, to remove existing thermal bridges through the frames, and secondly to remove condensations resultant from the monolayer enclosure. Thirdly, for aesthetic

reasons, the house intends to be unrecognizable as the combination of several accommodation cabins.

The new enclosure – both facades and roof – has to meet several conditions: it has to be as cheap as possible, light (so it can be easily assembled by two people) and ventilated (to prevent condensation). It also has to be attached to the frame by removable joints (bolted) and must eliminate thermal bridges –and for this we must ensure that the thermal insulation covers the entire frame, with a minimum thickness of 3 cm.

a) New outer horizontal enclosure: incorporating a ventilated facade.

The new facade is made using cement wood boards bolted on an auxiliary support structure made of treated pine wood battens. The battens enable the separation to provide space for a ventilated chamber and the reinforcing insulation.

b) New "vertical" enclosure: addition of a new roof.

The roof, which goes from a flat to a pitched roof, has dual mission. First, it changes the way the roof works: from a hot, no ventilated cover to a cool and ventilated one. Secondly, it modifies the parallelepiped geometry of the houses. The pitches drain inwardly, avoiding the formation of eaves. Also, the wood cement boards on the façades perform to strengthen the unit and attach the roof to the frame, and the new roofing (which one of the main requirements is the price) is nearly unseen from the outside.

Although most of the applied subsystems affect the enclosure, the entire interior of the home, from interior partitions to the service systems, is composed of catalogue components or prefabricated building systems and subsystems available on the market.

Building with accommodation cabins: an open project.

As already mentioned, a website that will provide to anyone¹⁰ the required documentation for building their own family housing is under construction

The website intends to spread information about:

- Different typologies and models of houses (comparable to some of the exposed typologies).
- The required documentation for the understanding and execution of the building system.
- Different manners of building houses, among which are:
 - a) the self-building method: possibility to build/assemble the house by only two people (usually on site).
 - b) pseudo-industrialized construction: possibility of off-site manufacturing, making each module almost prepared to be assembled on site. Though this building possibility is highly recommended, for obvious reasons, it may not be always possible.
- The calculations of insulation, service systems, etc.
- Recommended subsystems and components, indicating where to purchase them (usually on line) and their costs.

¹⁰ From all around the world, the page will be, at least, in two languages: Spanish and English.

The project, although initially restricted, aims to be open and fed back through the experiences of those who take part in it – the ones who build using the documentation spread through the web.

Bibliography

- Alfaro, J.L. & Andrés, M^a E. (2007). *Un análisis interregional del mercado inmobiliario en España*, Clm.economía (Revista económica de Castilla - La Mancha), Num. 11, pp. 111-138.
- Ayuso, J. & Restoy, F. (2003). *House prices and rents: an equilibrium asset pricing approach*, Journal of Empirical Finance, N^a 13, págs. 371-388.
- Ayuso, J. & Restoy, F. (2006). *House Prices and Rents in Spain: Does the Discount Factor Matter?*, Documento de Trabajo N^o 0609, Banco de España, Madrid.
- Balmaseda, M.; San Martín, I.; & Sebastián, M. (2002). *Una Aproximación Cuantitativa a la Burbuja Inmobiliaria; en Situación Inmobiliaria*, Servicio de Estudios- BBVA, Diciembre.
- Banco de España (2005). *Informe Anual 2005*, Madrid.
- Bellod, J.F. (2007). *Crecimiento y especulación inmobiliaria en la economía española*, Revista Principios: estudios de economía política, N^o 8, 2007, pp. 59-84.
- Bellod, J.F. (2011). *Detección de burbujas inmobiliarias: el caso español*, Contribuciones a la Economía, mayo 2011. Disponible en: <http://www.eumed.net/ce/2011a/>
- CECODHAS, Observatorio Europeo de la vivienda social (2006). *Vivienda Social en la UE 2005. Estadísticas y políticas clave por países*, Asociación española de promotores públicos de vivienda y suelo, Boletín Informativo N^o 84, Febrero 2006.
- CECODHAS, European Social Housing Observatory (2008), *Housing Europe 2007. Review of social, co-operative and public housing*. In: BSHF, Building and Social Housing Foundation (2008) *the 27 EU Member States*. Octubre 2008.
- Colau, A. & Alemany, A. *Vidas Hipotecadas*. Barcelona, Angle Editoriál-Cuadrilátero Libros, 2012. pp. 21-22.
- Colom, M.C. & Molés, M.C. (1998), *Un Análisis sobre el Gasto en Servicios de Vivienda en España*, Estadística Española, N^o 143, pp. 147-166.
- Colom, M.C.; Martínez, R.; & Molés, M.C. (2002). *Un Análisis de las Decisiones de Formación de Hogar, Tenencia y Demanda de Servicios de Vivienda de los Jóvenes Españoles*. Moneda y Crédito, N^o 215, pp. 199-223.
- Colom, M.C. & Molés, M.C. (2004). *Movilidad, tenencia y demanda de vivienda en España*. Estadística española, Vol. 46, Núm. 157, pp. 511 a 533.
- Davies, C. (2005). *The Prefabricated Home*. Reaktion Books, London.
- Ermisch, J.F.; Findlay, J.; & Gibb, K. (1996). *The Price Elasticity of Housing in Britain: Issues of Sample Selection*, Journal of Housing Economics, N^o 5, pp. 64-86.

- Fabra Garcés, L.A. (2009). *Reconversión del mercado inmobiliario y la vivienda como bien de uso*, Libertad digital Opinión (2009-01-19). Disponible en: <http://www.libertaddigital.com/opinion/autores-invitados/>
- García-Montalvo, J. (2004). *Políticas públicas y precio de la vivienda*, Cuadernos de Información Económica, N° 178, pp. 65-70.
- IMF (2004), *World Economic Outlook*, September, Washington.
- Inurrieta, A. (2007). *Mercado de vivienda en alquiler en España: más vivienda social y más mercado profesional*. Documento 113/2007, Fundación Alternativas. Disponible en: <http://www.falternativas.org/laboratorio/documentos/documentos-de-trabajo>
- Jaén, M. y Molina, A. (1994). *Un Análisis Empírico de la Tenencia y Demanda de Vivienda en Andalucía*, Investigaciones Económicas. N° 18, pp. 143-164.
- Friedman, A. (2001). *The grow home*. McGill-Queen's University Press, Montreal.
- Friedman, A. (2002). *The adaptable house: Designing homes for change*. McGraw-Hill, New York.
- Kieran, S. & Timberlake, J. (2004). *Prefabricating architecture: How manufacturing methodologies are poised to transform building construction*. McGraw-Hill, New York.
- King, M.A. (1980). *An Econometric Model of Tenure Choice and Demand for Housing as a Joint Decision*, Journal of Public Economics, N° 14, pp. 357-382.
- Kotnik, J. (2008). *Container architecture*. Links books, Barcelona.
- Lee, L-F. & Trost, R.P. (1978). *Estimation of Some Limited Dependent Variable Models with Application to Housing Demand*, Journal of Econometrics, 8, 357- 382.
- Martínez, J. & Maza, L.A. (2003). *Análisis del Precio de la Vivienda en España*; Documento de Trabajo N° 0307, Banco de España, Madrid.
- Naredo, J. M. (1996). *La burbuja inmobiliario-financiera en la coyuntura económica reciente (1985-1995)*. Siglo XXI de España, Madrid,
- Naredo, J.M. (2004). *Perspectivas de la vivienda*. Revista ICE n° 815 "Consecuencias de la evolución demográfica en la economía", mayo-junio, 2004, pp. 143-154.
- Naredo, J.M. (2010). *El modelo inmobiliario español y sus consecuencias*. Comunicación al *Coloquio sobre urbanismo, democracia y mercado: una experiencia española (1970-2010)*, Université Paris 12 Val-de-Marne.
- Panayotis, T. (2001). *La historiografía de la arquitectura moderna*, Ed. Marea/Celeste, Madrid.
- Rodríguez López, J. (1999). *Un análisis del mercado inmobiliario en España. Perspectivas*. Análisis local, N° 27, 1999, pp. 19-34.
- Rosen, H.S. (1979). *Housing Decisions and the U.S. Income Tax: An Econometric Analysis*, Journal of Public Economics, N° 11, pp. 1-23.
- Smith, Ryan E. (2010). *Prefab Architecture (A Guide to Modular Design and Construction)*. John Wiley & Sons, Inc., New Jersey.
- UN (2011). *Special Rapporteur on adequate housing as a component of the right to an adequate standard of living, and on the right to non-discrimination in this context*. A/67/286, 10 August 2012.

Figure 1. Different accommodation cabin typologies

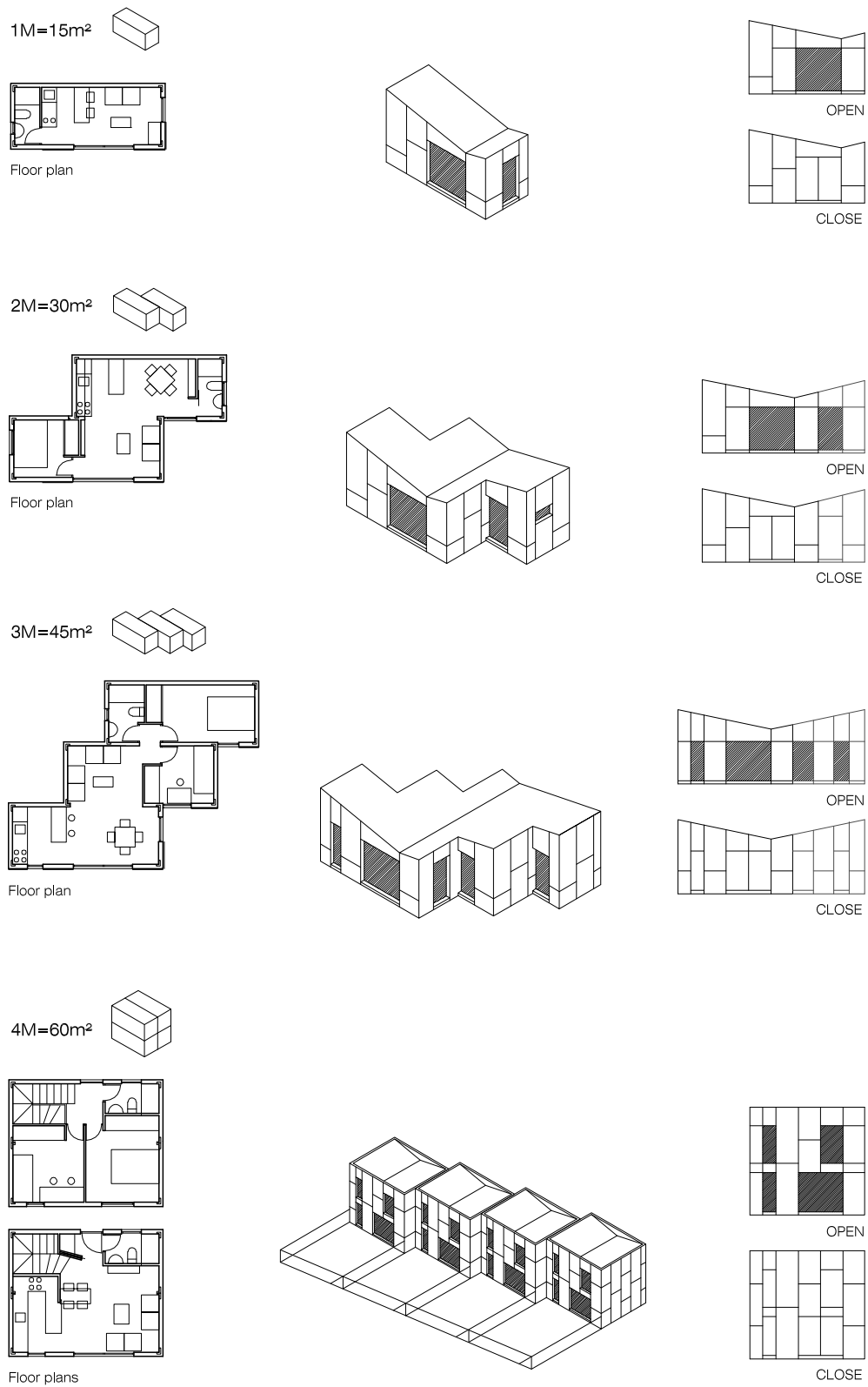
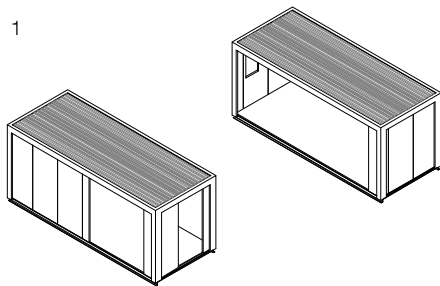
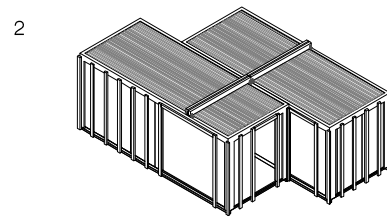

Figure 2. Assembly of a two-module housing



1- Sandwich panels: trim and rearrange.



2- Ventiladed facade's auxiliar support structure: battering.

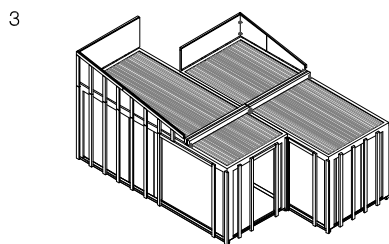

3- Assembly of roof parts .

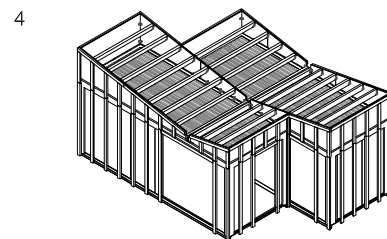

4- Assembly of roof joist.

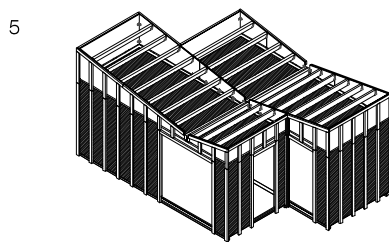

5- Thermal insulation improvement.

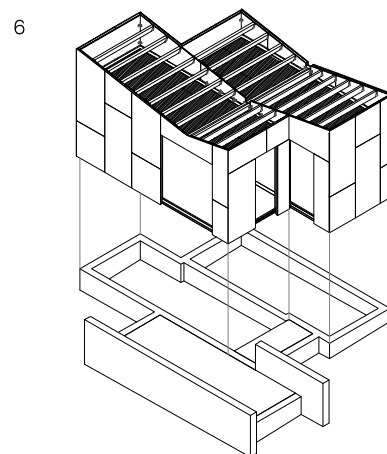
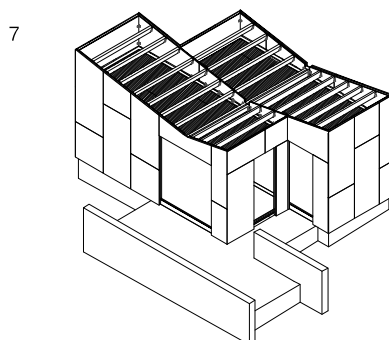
6, 7- Assembly of facade wood cement board.
Air chamber for ventilation underneath modules.

7

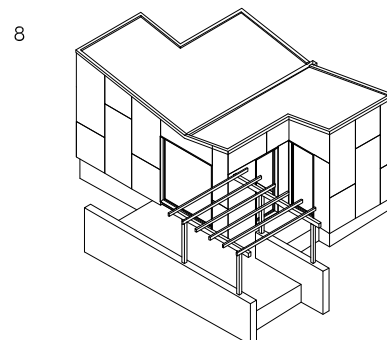

8