

Non-linear gain – look-up table based approach for modeling a family of DC to DC converters based on transient response analysis

San Román, P.; Oliver, J.A.; Alou, P.; García, O.; Cobos, J.A.; Prieto, R.

Abstract — The purpose of this work is to propose a structure for simulating power systems using behavioral models of non-linear DC to DC converters implemented through a look-up table of gains. This structure is specially designed for converters whose output impedance depends on the load current level, e.g. quasi-resonant converters. The proposed model is a generic one whose parameters can be obtained by direct measuring the transient response at different operating points. It also includes optional functionalities for modeling converters with current limitation and current sharing in paralleling characteristics. The proposed structured also allows including additional characteristics of the DC to DC converter as the efficiency as a function of the input voltage and the output current or overvoltage and undervoltage protections. In addition, this proposed model is valid for overdamped and underdamped situations.

Index Terms—Behavioral, CAD, DC-DC power converters, modeling, systems.

I. INTRODUCTION

IN large power systems, simulation is nowadays a basic and very powerful tool to analyze its overall stability and its performance. This is due to its relatively low cost, reliability and possibilities to obtain a great amount of information from complex systems relatively fast and easily.

The objective of this work is to propose a methodology to design behavioral black-box models of, preferably, non-linear DC to DC converters; although this structure will be also valid for any converter where the output impedance depends on the output current level as in quasiresonants and in current-fed ones.

This model is based on a first stage that defines the basic dynamics of the converters and a second non-linear stage based on a variable gain implemented with a look-up table.

This model also embodies DC electrical performance using efficiency tables as a function of the input voltage and of the output current. It is also specially indicated to design converters with secondary control pins (normally used for current limitation purposes) and large or complex systems

with several converters in parallel joining Master-Slave architecture.

So, first, the current state-of-the-art in DC-DC converters modeling will be exposed, showing the advantages and drawbacks that the proposed procedure owns compared to the previous ones.

The referred scenario is formed, in principle, by parametric models, Wiener-Hammerstein structure based models, polytopic models and models based in the dynamic response.

Then, the proposed model will be explained and analyzed by isolating the most important stages and showing a possible and recommended implementation in Cadence Orcad.

Finally, the model will be validated through its application in a real case: modeling a Vicor 300VMaxi DC to DC converter used in the power stage of an electronic antenna for an airborne application¹.

II. CURRENT STATE OF THE ART

A. Parametric Models

Parametric models [1, 2, 3] consist in behavioral VHDL-AMS generated mixed-signal models, based on a Wiener - Hammerstein structure created through parameter extraction from datasheets (Figure 1). They usually include three levels of abstraction: static model, dynamic model and an additional event driven behavioral model that simulates mosfet's turn-on and turn-off delays.

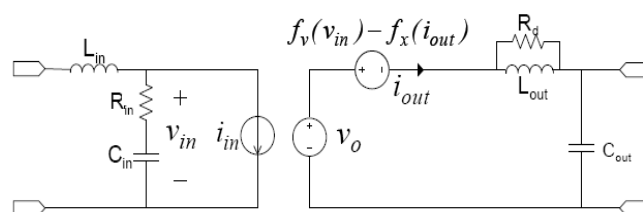

Figure 1. Parametrical static and dynamic model

In parametric models the output voltage is implemented by its nominal value plus the variation due to changes in the input voltage and in the output current. The power processing is modeled by a dependant current source that depends in the efficiency of the converter in each operating point.

¹ This work was supported in part by Indra Sistemas S.A.

Additionally, it also has a thermal model made from data extracted from datasheets.

The parameters of this structure are estimated applying numerical methods and experimental equations to the data inputs obtained by in-situ measurements or simply taking them from its datasheets.

The main advantage of this model is the capability to perform an analysis of the dynamic and thermal behavior in converters with protections, multiple outputs, cross-regulations, current share and remote control.

But, unfortunately, this model is only valid if the converter response is linear or almost linear in every working point, so it will be very useful for its purpose as long as non-linear effects are neglected.

B. Polythopic models

A further approach to simulation of non-linear DC to DC converters for system-level design and analysis are the polythopic models [4] (figure 2). This method is based on the creation of several linear subspaces (monodimensional or bidimensionals) inside a non-linear space of operation which is the junction of all subspaces.

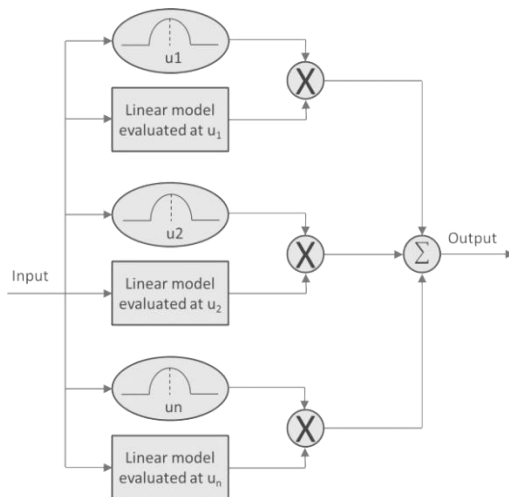

Figure 2. Polythopic models

Each subspace define its own frequency response functions or FRFs, so the design inputs will be the usual following four frecuencial gains: audio-susceptibility, output impedance, input impedance and current gain. Those gains depend on the switching frequency and on the output current.

Depending on the operating point an auxiliar bidimensional scheduling function will determine in which subspace the converter is working at each moment. In the case that the operating point is between the boundaries of two subspaces, the behavioral response of the converter will be a weighted-average of each subspace.

A model obtained by this method will be valid either for CCM or DCM.

The main disadvantage of this model is the need of doing a large amount of complex measurements in order to obtain it.

C. Converter Dynamic Response Based Models

Another methodology is the based on the transient response analysis [5, 6, 7]. It could be seen as an intermediate technique for modelling between parametrics and polytropics, because it uses both a Weiner-Hammerstein structure and a polythopic block.

This method swappes the fixed dynamic block of a parametric model (consisting in an inductance and a resistance in parallel) for some variable impedance Z_o , which changes the same (and previously explained) way as in a polythopic model, as seen in Figure 3.

Unfortunately, the models obtained with this method seem to fail at high frequency. Anyway, the technique proposed in this document is also based in the measurement of the modeled converter dynamic response.

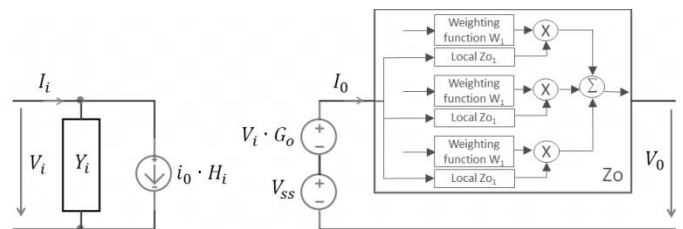

Figure 3. Transient response based models

D. Wiener-Hammerstein structure based models

This method is similar to parametric structures but includes a non -linear block in the output branch [8] (Figure 4). The proposed model is similar to this model in the way the upper level is designed, but not in the way the non-linear effects are modeled.

This model does not also have an implementation of the secondary control that will determine how the converter could be regaluted from outside and does not take into account the multiple protections and thresholds which a regular COTS converter is equipped with.

The proposed model is developed from this methodology.

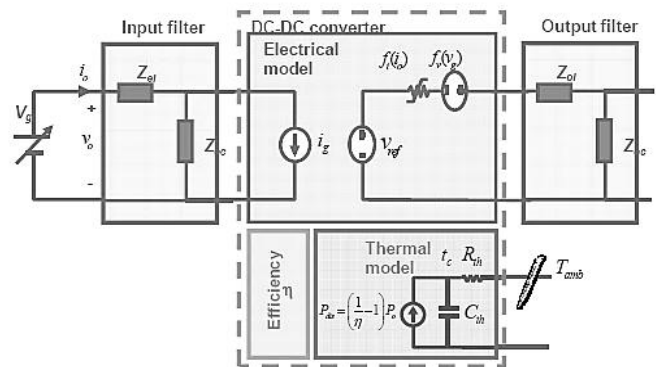

Figure 4. Wiener-Hammerstein non-linear structures

III. PROPOSED MODEL BASED ON TRANSIENT RESPONSE ANALYSIS

As mentioned, the proposed model is a modification of the Wiener-Hammerstein structure based models. It is, basically, its current dual, as shown in Fig 5.a. The gain of its feedback loop should be the inversion of the parallelization of the parallel output impedance and of the series output filter impedance used in the Wiener-Hammerstein model.

In order to allow the model to behave non-linearly, some additional block had been included: Overvoltage, undervoltage and overcurrent protections, a non-linear gain and a compensator block (a phase lead-lag network), only used if the frequencial gains of the converter and of the model are slightly different.

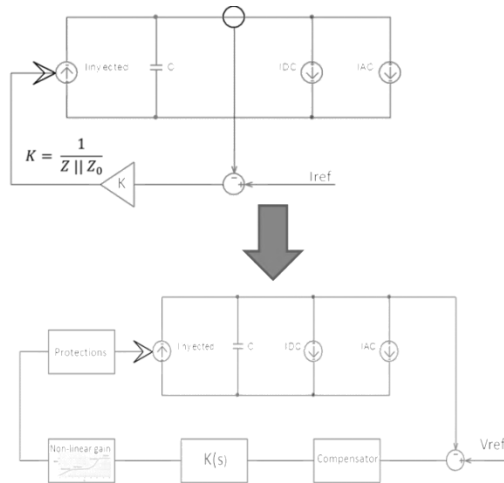

Figure 5.a and 5.b. Current dual of a Wiener-Hammerstein model and block addition to implement non-linear behavior

The final model structure will have two feedback loops: an output voltage feedback and a secondary control loop (usually used for current limiting purposes), in order to obtain a valid error reference for the dynamics.

This error is taken as the input of a dynamic block based on capacitances and resistances. Then, the non-linear behavior changes will be achieved with a non-linear gain.

Some additional blocks control that the behavior of the protections will work properly as in the real converter. The efficiency is modeled as in a Wiener-Hammerstein structure, considering that it is dependent on the input voltage and in the output current (in general terms, neglecting all small time effects, so it is).

COTS converters are usually manufactured with voltage sensing pins, and control pins in order to make possible output current limitation from outside, among other features. This is a very useful feature for systems that require constant current at the input or for PFC purposes. This input typically incorporates, internally, in parallel, a low voltage source (V_{int} , about 1 to 5 volts) in series with a resistor, so when the pin is unconnected or the limiting reference is under V_{int} , this pin will refer V_{int} volts.

In the proposed model, this limiting reference is compared with the sensed output voltage and an error is generated, in the way a converter does, bridging the gap. In steady state, this error will be null and output voltage will be regular. This first constructive block can be seen in figure 6.

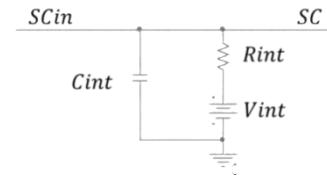

Figure 6. Reference generator from datasheet

The whole, basic and previously explained block diagram of the proposed model is presented below in Figure 7.

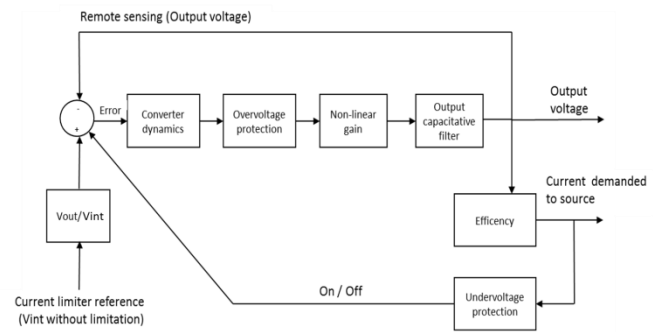

Figure 7. Proposed model blocks diagram

The main structure (Figure 8) is so similar of those used in parametrical or Wiener-Hammerstein structure based models, but in this case the output voltage level is generated through a current source in parallel with an appropriately adjusted, high impedanced resistance (to assure convergence). The voltage loop will maintain the output voltage at its required DC level.

The model also takes into account the variations in the output voltage due to the output current value (load managed by the DC to DC converter) through a series resistance (that could be also taken into account in the feedback loop). Finally an output capacitance is included at the output in order to simulate properly the output voltage temporal and frequencial response.

In the primary side, the input current required by the converter is modeled with an optional inductive-capacitive input filter (only when it is needed) and a current source that demands the input current as the result of a power balance, considering the real efficiency, dependent on the input voltage and in the output current and obtained through appropriated look-up tables (LUTs).

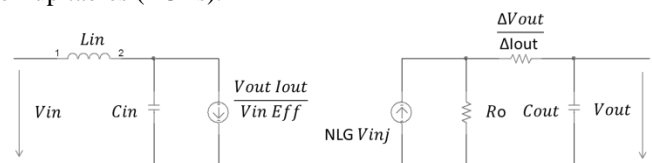

Figure 8. Top level Wiener-Hammerstein type structure

The most important difference respect previous modeling paradigmas is the way the output voltage is generated. In this proposed model this is done by applying a non-linear gain (NLG, dependent mainly on the injected current) to the injected current reference (V_{inj} , as a voltage level) obtained as seen below in figure 9. This voltage level reference will be very useful to simulate complex systems with several converters in parallel, though it will be the reference used to control the slave converters when using a Master-Slave architecture for simulation. In the slave models only the upper Weiner-Hammerstein structure is needed as they have two special inputs, one for the injected current reference (V_{inj}) and the other for the efficiency value (V_{eff}). This technique brings a much shorter simulation time, which results a more efficient setting-and-debugging of the system.

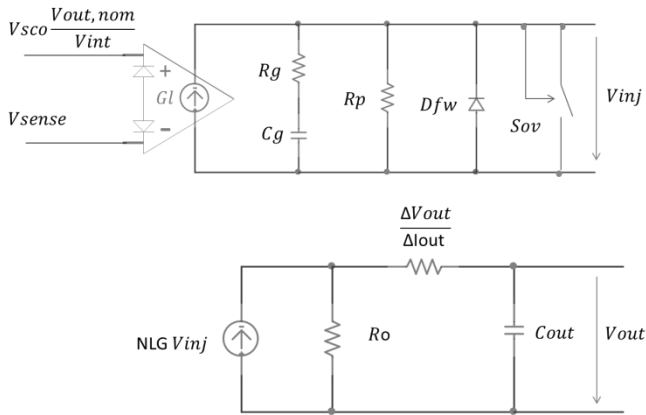

Figure 9. Injected and output current generation

Continuing the technical description, the injected current reference is generated by a dynamic stage which take as an input the resulting error of the comparison between the sensed output voltage (V_{sense}) and the reference provided by the secondary control (SC, current limiter) as seen in figure 8 (where $V_{out,nom}$ is the nominal output voltage and V_{sco} is the SC reference obtained in figure 6, V_{int} is the internal voltage reference provided by the converter in the secondary control pin) and multiplied by a linear gain GL , correspondant to the gain of the transconductance amplifier.

The dynamic stage is the dual, current equivalent of an voltage LC filter and consists in a resistor in parallel with a RC line and a free-wheeling diode, necessary for some hypothetical light load rare cases where the input current of this stage in negative.

A properly adjusted switch is placed at the end of this stage in order to provided additional overvoltage protection.

The transfer function of this stage is the following:

$$V_{inj} = R_p \frac{1 + 2R_g C_g s}{1 + 2R_p C_g s} GL (V_{sco} \frac{V_{out,nom}}{V_{int}} - V_{sense})$$

In other terms, the non-linear gain NLG will depend on the specific converter that is been modeled, but it will usually increase faster as the output current increases until a point of saturation where the converter is not suppose to work in. So, if the maximum output current is modeled, there will be a point from which the gain will be constant. The negative gain should be also carefully introduced into the model in order to avoid clampings in the output voltage (current should be allowed to return through the output capacitor when needed). In the figure below, it is shown a typical relationship between the injected current (as V_{inj}) and the applied current $NLG V_{inj}$:

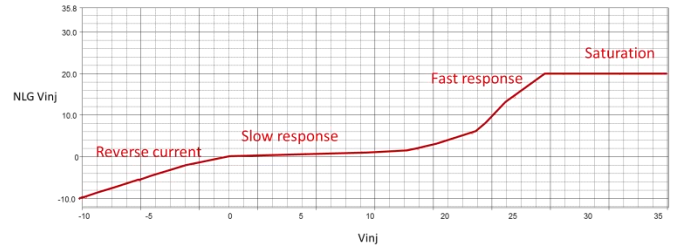

Figure 10. Non-linear gain possible shape

Summarizing, the good performance in a transition between two very differents operation points is inherent to the model obtention process. That means, if the parameters are adjusted adequately, the model will perform those transitions in the proper way.

IV. MODEL OBTENTION EXAMPLE

In order to give a comprehensive example of the obtention of this structure, a model of a 500W military COTS Vicor 300Vmaxi module will be obtained. In this case, the Vicor module operates with an input voltage of 270V and an output voltage of 48V in steady-state. This module, internally, is a Quasi-Resonant Forward Converter with Active Clamp, designed to obtain very high efficiency (above 88%).

In the beginning, there were some attempts to modelate this converter using the previously listed traditional techniques like parametrical modeling, but they revealed as insufficient for the purposes of this model. The reason of that is shown in Table 1, where transient voltage drops are presented for 1A pulses with some output current bias value. Theses values appeared to be highly non-linear:

Iout DC level	$\Delta V_{measured}$	$\Delta V_{simulated}$
0A	1.7V	1.6V
1A	600mV	640mV
5A	350mV	350mV
9A	200mV	203mV

Table 1. Transient voltage drops

The first step of the modeling process was obtaining valid measurements of the converter without any other additional elements but resistives or electronics loads (e.g. output capacitances). The measurements needed were the output

voltage transient response to output current steps of 1A with different levels of continuous current (establishment times and overshoots) and the efficiency in different operating points (varying both load and input current). Also, there were taken measurements of the protections of the converter as minimum and maximum input voltages accepted or the maximum output current. In the figure below (Figure 11) are shown, as an example, the measured efficiency and the voltage transient response due to an output current pulse from 4A to 5A.

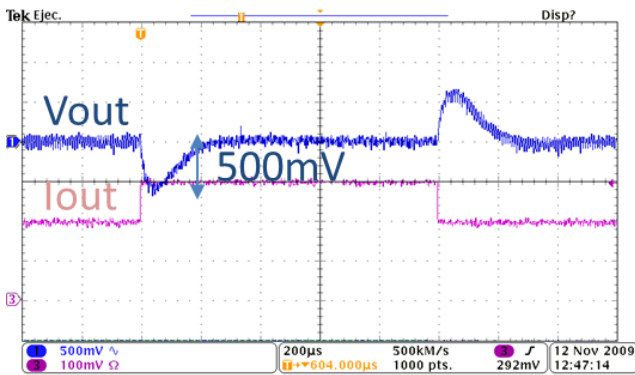
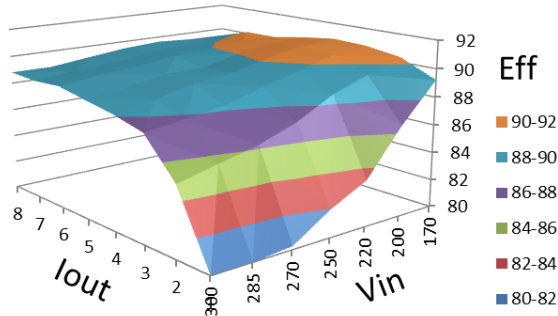

Figure 11. Measurements taken from the DC-DC module

The second step was the obtention of the parameters of the model (Lin , Cin , Ro , $Cout$, Rg , Cg , Rp , $Voutnom$, $Vint$, GL and the most important non-linear gain NLG) through inspection in an iterative process, until the required precision is obtained. The parameters should be adjusted in a specific order.

In this example, Cadence Orcad was used to obtaining the model.

First, physical parameters as $Vint$, $Voutnom$, Lin , Cin and $Cout$ were taken directly from the measurements. Then either Rp or Ro were fixed at, for instance, $1M\Omega$; this will prevent the simulator of creating inductive or capacitive loops and will allow fast convergence. After this, Rg and Cg should be changed, mantaining constant GL and all NLG elements, until the transient response “shape” due to a determined load step of the simulation model matches the real one using the same load step. Finally GL and the non-linear gain look-up table will be adjusted. This process will be complete when the model behavior matches the real converter behavior in all required operating points.

V. MODEL VALIDATION

The comparison of the actual oscilloscope measurements (blue) and the model generated response (red) is shown below in figures 12 to 14. It can be seen that the adjustment obtained is good enough for an accurate and reliable system-level analysis.

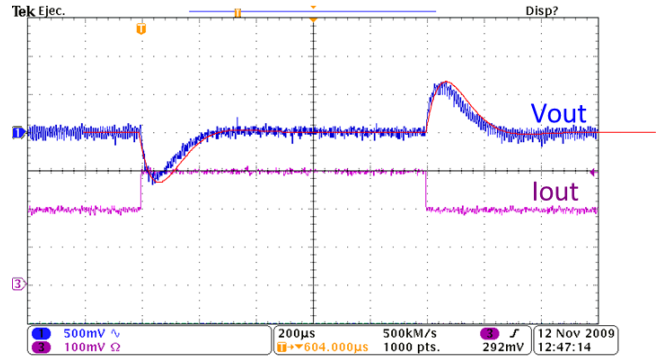

Figure 12. Transient due to a 1A step from a 2A dc level

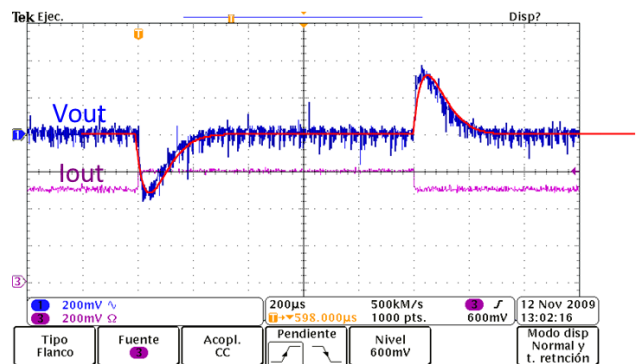

Figure 13. Transient due to a 1A step from a 5A dc level

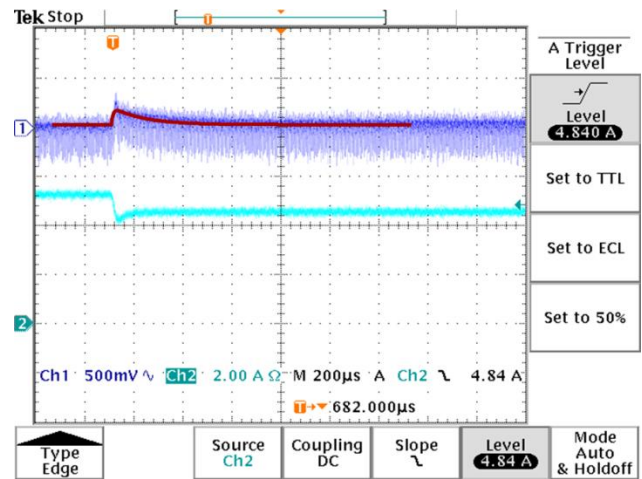

Figure 14. Transient due to a 1A step from a 6A dc level

VI. POWER SYSTEM SIMULATION EXAMPLE

The previously validated model was used to simulate a large power architecture: an electronic radar power stage. This power stage is used in order to provide energy to the antenna, both for the transmission modules and the reception ones (Figure 15). The antenna is divided into four equal quadrants.

The sinusoidal voltage produced by the aircraft generator is rectified through an uncontrolled wave rectifier and an input capacitive filter (in order to assure overall stability and provide an acceptable ripple). Then the power is distributed into three main DC-DC blocks for each one of the four antenna quadrants. Each quadrant is supplied by two transmission blocks and a reception one (transmission power is around twice the reception power). All this blocks are internally equal and they consist in two PCBs in parallel. Meanwhile, a PCB consist two DC-DC converters in parallel that share an EMI filter. With this structure a high level of redundancy, and therefore, failure tolerance is assured.

Finally, in order to maintain the voltage drop at the output as low as possible a capacitive filter is placed between the antenna and the DC-DC stage. The main requirements of the power stage are the following: no more than 3V voltage drop at the output and an input current as constant as possible, with a load consisting in high current pulses.

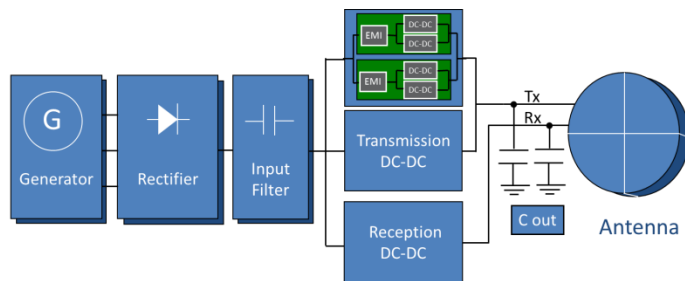

Figure 15. Radar power architecture simulated

This architecture was implemented and simulated in Pspice using the previously developed model of the DC-DC converter and the results of this simulation were used to check that the architecture meets all the requirements and to improve the power chain. In the figure below (Figure 16) is presented the system's output voltage drop and the current demanded by the antenna at some point.

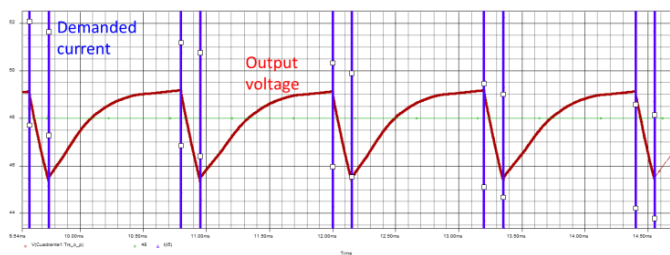

Figure 16. Some system's simulation results

VII. CONCLUSION

This work proposes a methodology for black-box modeling of commercial non-linear DC-DC converters that can be used to characterize modules whose output impedance depends on the output current level.

The proposed paradigma for modeling system-level DC-DC converters provides several advantages: obtention of very fast and accurated simulations, ease to control slaves converter in a Master-Slave arquitecture, possibilities to model highly non-linear converters as resonants converters among some others ones.

The main drawbacks are the adjustment of large number of model parameters and the necessity of taking accurated, but not really complex, measurements of the transient response and of the efficiency on different operating points. But this is always mandatory if an accurated model is required.

REFERENCES

- [1] Prieto, R.; Laguna, L.; Oliver, J.A.; Cobos, J.A.; "DC/DC Converter Parametric Models for System level Simulation" *Applied Power Electronics Conference and Exposition, 2009. APEC 2009. Twenty-Fourth Annual IEEE. 2009, Page(s): 292 – 297.*
- [2] J. A. Oliver; R. Prieto; V. Romero; J.A. Cobos.; "Behavioral Modeling of DC-DC Converters for Large-Signal Simulation of Distributed Power Systems". *Applied Power Electronics Conference and Exposition, 2006. APEC '06. Twenty-First Annual IEEE*
- [3] R. Prieto; L. Laguna-Ruiz; J. A. Oliver; J. A. Cobos; "Parameterization of DC/DC Converter Models for System level Simulation". *Power Electronics and Applications, 2007 European Conference on. 2007, Page(s): 1 – 10.*
- [4] L. Arnedo; D. Boroyevich; R. Burgos; F. Wang, "Polytopic Black-Box Modeling of DC-DC Converters". *Power Electronics Specialists Conference, 2008. PESC 2008. IEEE. 2008, Page(s): 1015 – 1021.*
- [5] Valdivia, V.; Barrado, A.; Lazaro, A.; Zumel, P.; Raga, C.; "Easy Modeling and Identification Procedure for "Black Box" Behavioral Models of Power Electronics Converters with Reduced Order Based on Transient Response Analysis", *Applied Power Electronics Conference and Exposition, 2009. APEC 2009. Twenty-Fourth Annual IEEE. 2009, Page(s): 318 – 324.*
- [6] Valdivia, V.; Barrado, A.; Laazaro, A.; Zumel, P.; Raga, C.; Fernandez, C.; "Simple Modeling and Identification Procedures for "Black-Box" Behavioral Modeling of Power Converters Based on Transient Response Analysis". *Power Electronics, IEEE Transactions on. 2009, Page(s): 2776 – 2790.*
- [7] Valdivia, V.; Barrado, A.; Lazaro, A.; Fernandez, C.; Zumel, P.; "Black-box modeling of DC-DC converters based on transient response analysis and parametric identification methods". *Applied Power Electronics Conference and Exposition (APEC), 2010 Twenty-Fifth Annual IEEE. 2010, Page(s): 1131 – 1138.*
- [8] Oliver, J.A.; Prieto, R.; Cobos, J.A.; Garcia, O.; Alou, P., "Hybrid Wiener-Hammerstein Structure for Grey-Box Modeling of DC-DC Converters" *Applied Power Electronics Conference and Exposition, 2009. APEC 2009. Twenty-Fourth Annual IEEE. 2009, Page(s): 280 – 285.*