

Studies of a Self Cooled Lead Lithium Blanket for HiPER Reactor

R. Juárez^{1,2}, J. Sanz^{1,2}, C. Sánchez², C. Zanzi³, J. Hernández³, and J.M. Perlado¹

¹Instituto de Fusión Nuclear, UPM/UNED, C/Jose Gutiérrez Abascal 2, Madrid, Spain

²Dept. de Ingeniería Energética, ETSII, UNED, C/ Juan del Rosal 12, Madrid, Spain

³Dept. de Ingeniería Mecánica, ETSII, UNED, C/ Juan del Rosal 12, Madrid, Spain

Abstract. Within the frame of the HiPER reactor, we propose and study a Self Cooled Lead Lithium blanket with two different cooling arrangements of the system First Wall – Blanket for the HiPER reactor: Integrated First Wall Blanket and Separated First Wall Blanket. We compare the two arrangements in terms of power cycle efficiency, operation flexibility in out-off-normal situations and proper cooling and acceptable corrosion. The Separated First Wall Blanket arrangement is superior in all of them, and it is selected as the advantageous proposal for the HiPER reactor blanket. However, it still has to be improved from the standpoint of proper cooling and corrosion rates.

1 Introduction

The HiPER reactor is conceived to be a 1500 MWth reactor, based in direct drive shock ignition and dry wall technologies. From this stating point, it is necessary to propose and optimize a tritium breeding blanket for the reactor. In this paper we propose and study a Self Cooled Lead Lithium blanket with EUROFER structure. There is the possibility of decoupling the First Wall and the Blanket cooling what represents two different First Wall-blanket arrangements: Integrated First Wall Blanket (IFWB) and Separated First Wall Blanket (SFWB). For both of them, we have assessed and compare some critical performances of the reactor: Tritium Breeding Ratio (TBR), power cycle efficiency, response against cooling accidents, proper blanket cooling and corrosion rates inside the blanket.

2 Self Cooled Lead Lithium Blanket

We propose a starting design Self Cooled Lead Lithium with EUROFER structure. This design proposal is aimed to be modified as different studies answers open questions. It is conceived to be arranged as shown in the figure 1. It is divided in two different hemispheres. Every hemisphere is divided into 8 modules. All the EUROFER sheets are 1cm thick, unless other thickness is specifically mentioned. Every module has a thin inlet channel and a thick outlet channel. The inner channel is comprised between radius 6.51 m and 6.59 m (8 cm thickness channel). The outlet channel is comprised between radius 6.81 m and 7.47 m (66 cm thickness channel). The inlet temperature is 350°C and the desired outlet temperature is 450°C.

A neutronic analysis of this blanket proposal has been performed regarding with Tritium Breeding Ratio (TBR) and blanket energy gain (η_B). The TBR results to be as high as 1.38 for the reference design. Then, we have computed the TBR as function of the First Wall steel substrate thickness. The maximum FW substrate thickness has been found to be as 5.5 cm to obtain a $TBR > 1.15$ [1]. This result opens the possibility of decoupling the cooling of the blanket and the First Wall. The η_B is 1.18.

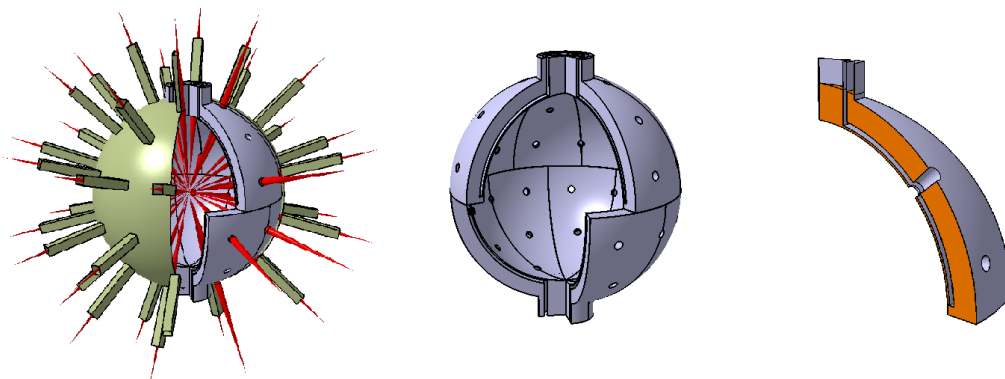

Fig. 1. Blanket and vacuum chamber of HiPER reactor

2.1 First Wall - Blanket cooling arrangements

The neutrons generated in the ignition will deposit their energy (75% of the generated energy, $1125 \cdot \eta_B = 1327.5$ MW) in the Lead Lithium (LiPb) and the structure of the blanket. The ions and X-Rays produced in the ignitions will deposit their energy (25% of the generated energy, 375 MW) directly into the First Wall, as HiPER reactor is a dry wall concept. In the first approach to the problem, the energy deposited in the FW is transferred to the LiPb and it is evacuated together with the neutron energy deposition. This option is called the Integrated First Wall – Blanket arrangement. However, given the neutronic performance of the starting design, it is possible to decouple the FW and blanket cooling. Both First Wall – Blanket options are shown in picture 2.

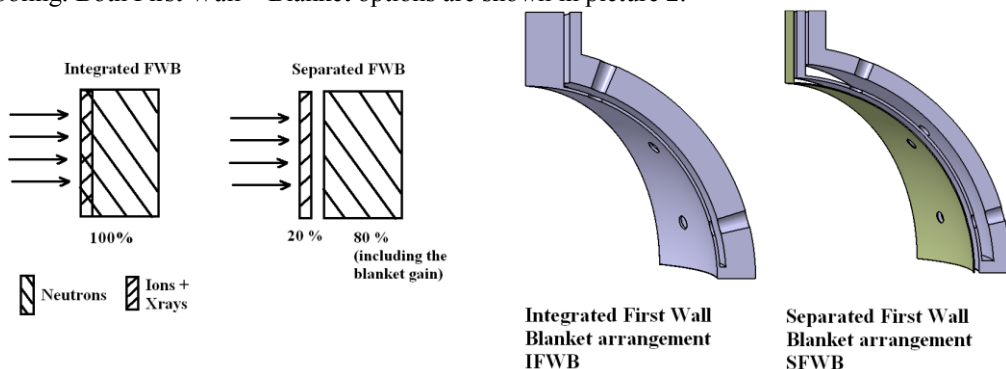

Fig. 2. Neutron, ion and X-Ray energy deposition in IFWB and SFWB

There are different potential improvements in the blanket performance that motivate the decoupling of the FW and blanket cooling. First of all, the ions and X-Rays energy will raise the LiPb temperature/velocity with no extra TBR advantage. The SCLL is characterized by a fast flowing LiPb, and corrosion can be a threat. Then, by reducing the LiPb temperature/velocity the corrosion rates can be partially mitigated. The FW could be built of ODS-EUROFER, allowing a maximum temperature of 650°C for its cooling circuit. In addition, the separated First Wall could be cooled with a branch of Helium coming from the secondary circuit if Helium is used as working

fluid for the power cycle conversion, as it is in this study. This Helium re-heating, from 450°C to 650°C can increase the power cycle efficiency. And the introduction of a second cooling/heating independent circuit inside the Vacuum Vessel could be used to add extra operation margins in out-off-normal situations.

3 Helium Brayton Power Cycle

As a first approach to the power conversion issue, we have decided to study a Helium Brayton [2, 3] Power cycle for both IFWB and SFWB. They are shown in the figure 3.

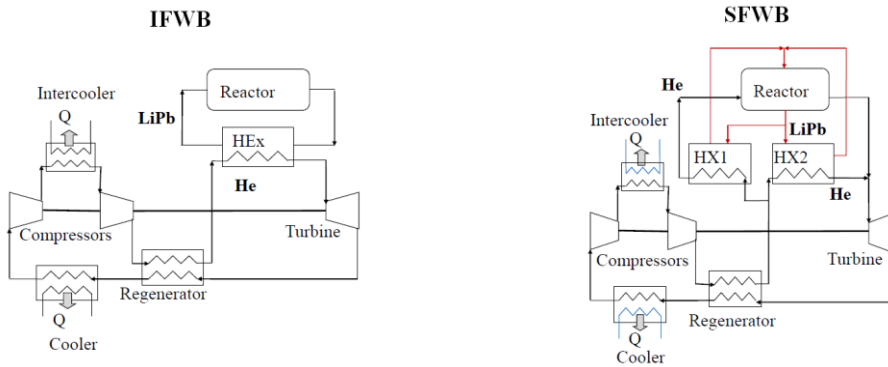

Fig. 3. Helium Brayton power cycle for the SCLL blanket of HiPER reactor

A regenerative and intercooling helium Brayton cycle is proposed for both configuration. In the SFWB configuration, the proposed power cycle integrates the two energy sources. The efficiency of the power cycle for the IFWB is 37.5%, while for the SFWB is 38.5%.

4 Loss of active cooling

The study of the consequences of a severe accident in HiPER reactor exceeds the scope of this paper. Instead of severe accidents, we have first focused on out-off-normal situations, where the SCLL blankets are limited for having only one single heating/cooling circuit. In these situations, such as the loss of active cooling, there are two main threats identified: LiPb solidification inside the blanket and the structure mechanical degradation. The specific threat will depend on the previous irradiation to the loss of coolant accident, given that residual heat can be very important.

We have developed a simple computational model for the heat transfer studies of the SCLL blanket for HiPER reactor, and compared the operation flexibility in these situations for the both arrangements: IFWB and SFWB. The IFWB is very limited. In the absence of residual heat in 40 hours the LiPb becomes solid inside the blanket. This is the maximum time to evacuate it from the blanket. But, after 5 years of irradiation, the residual heat is such that in 10 hours the structure temperature has overcome the limit of 550°C. Above this temperature, the creep rupture can represent a threat for the EUROFER structure. In the case of the SFWB, the FW independent cooling circuit could be adapted to operate as auxiliary heating/cooling circuit if it were in thermal contact with the blanket. Our calculations show that some MWs of heating/cooling capacity would be enough for this circuit to avoid both risks: solidification of LiPb inside the blanket and structural properties deterioration. Some MWs for auxiliary operation should not represent a design threat for a circuit which in normal operation will extract around 450 MWs from the FW.

5 Active cooling and corrosion

The proper cooling of the blanket can be synthesized in the three following requirements:

1. **Average outlet temperature of LiPb of 450°C**, a compromise between power cycle conversion and corrosion rates in the plant [4].
2. **Maximum local temperature of LiPb inside the blanket of 550°C**, to fulfil the EUROFER criterion on creep rupture behaviour [5].
3. **Maximum corrosion rate inside the blanket of 200 $\mu\text{m}/\text{yr}$** . After 5 years of lifetime of the blanket, the total corrosion would be 0.1mm, the 10% of the structure thickness [4].

Table 1. Cooling parameters of the IFWB and the SFWB

	Power in the LiPb (MW)	LiPb mass flow (kg/s)	Max. corrosion rate ($\mu\text{m}/\text{yr}$)	T_{max} (°C)	T_{out} (°C)
IFWB	1702.5	12100	3300	539.5	395.5
SFWB	1327.5	9700	2700	515	395.5

We have computed the temperature and corrosion maps [6] for the IFWB and SFWB arrangements, with the cooling parameters shown in table 1. The mass flow rate has been fixed in order to keep the temperature below the local upper limit of 550°C in both cases.

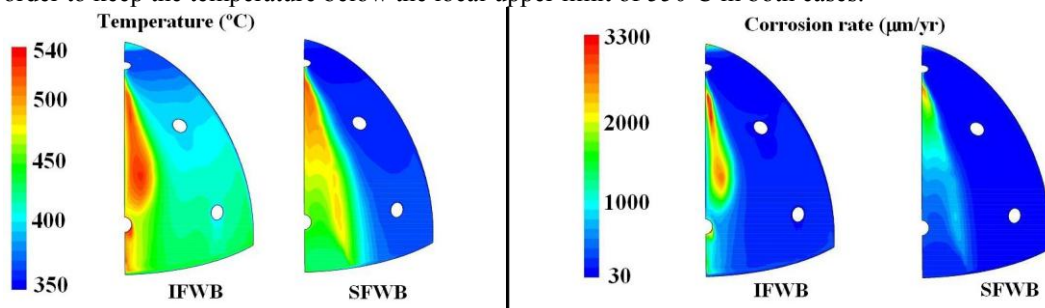

Fig. 4. Temperature and corrosion rates maps of the IFWB and the SFWB

It is a found, as expected, and improvement in the performance (max. local temperature and corrosion rates) in the case of SFWB compared to the IFWB (see table 1). However, there is still a need for improvement. As shown in the figure 4, there is a large LiPb area recirculation in the blanket inlet for both the IFWB and SFWB. It is responsible for the bad performance of both arrangements in terms of low outlet temperature and high corrosion rates. Further modifications of the blanket design will take into account this fact to improve the cooling.

6 Conclusions

We have proposed and study a SCLL blanket with two different arrangements for the First Wall - Blanket cooling system for the HiPER reactor: IFWB and SFWB. We have compared them in terms of power cycle efficiency, out-off-normal situations and cooling and corrosion. The SFWB is superior in all of these fields and it is chosen for further studies as the advantageous option. However the SFWB still has to be modified to improve the cooling and corrosion performance.

Bibliography

1. L. A. El-Guebaly, S. Malang, *Fusion Engineering and Design* **84** (2009) 2072-2083
2. T. J. Dolan, *Fusion Research, Pergamon International Library III* (1980) 747-748
3. R. Juárez, C. Sánchez, J. Sanz, J.M. Perlado, *submitted to Fusion Engineering and Design*
4. S. Malang, A.R. Raffray, N.B. Morley, *Fusion Engineering and Design* **84** (2009) 2145-2157
5. S. J. Zinkle, N. M. Ghoniem, *Journal of Nuclear Materials* **417** (2011) 2-8
6. J. Sannier, T. Dufrenoy, T. Flament, A. Terlam, *Journal of Nucl. Mat.* **191-194** (1992) 975-978