

Metro de Madrid rolling stock models and comparative studies relating to comfort

F. J. Gonzalez, J. F. Blanquer, B. Suarez and P. Rodriguez

This paper presents the work carried out by Metro de Madrid and the Railway Technology Research Centre (Polytechnic University of Madrid), aimed at setting up rolling stock simulation models with a high level of detail. To do this, the features of the SIMPACK simulation tool used to create models have been briefly outlined, explaining the main features of models in two of the series modelled: 7000 and 8000. Finally, the results obtained from comparing comfort in the 7000 and 8000 series are presented.

The final, definitive version of this paper has been published in Proceedings of the 6th International Conference on Railway Bogies and Running Gears, Budapest, Hungary, 13-16 September, 2004.

When citing this work, please refer to the published paper:

C. Vera, J. Paulin, B. Suarez and M. Gutierrez, Metro de Madrid rolling stock models and comparative studies relating to comfort. Proceedings of the 6th International Conference on Railway Bogies and Running Gears, Budapest, Hungary, 13-16 September, 2004.

METRO DE MADRID ROLLING STOCK MODELS AND COMPARATIVE STUDIES RELATING TO COMFORT

F. J. GONZÁLEZ, J. F. BLANQUER, B. SUAREZ and P. RODRÍGUEZ

Management of engineering, maintenance and research development
Metro de Madrid, S.A.
C/Cavanilles 58
28007 MADRID, SPAIN

SYNOPSIS

This paper presents the work carried out by Metro de Madrid and the Railway Technology Research Centre (Polytechnic University of Madrid), aimed at setting up rolling stock simulation models with a high level of detail.

To do this, the features of the SIMPACK simulation tool used to create models have been briefly outlined, explaining the main features of models in two of the series modelled: 7000 and 8000. Finally, the results obtained from comparing comfort in the 7000 and 8000 series are presented.

1 INTRODUCTION

1.1 Rolling Stock Research projects in Metro Madrid.

Over the last eight years, Metro de Madrid has carried out ambitious expansion plans, the consequence of the investment effort made by the Madrid Region, and which has led to the network increasing from 126 km to 230 km. As a consequence of these expansion plans, 662 cars have been bought, distributed into 3 new series, 2000B, 6000, 7000, 8000. The network is planned to grow by more than 70 kilometres over the next four years, line 3 being completely altered and various re-signalling, power supply voltage changes, and lift installation work, etc being undertaken. Nearly 700 new cars will also be purchased. All of these activities are under way at the time of writing this paper.

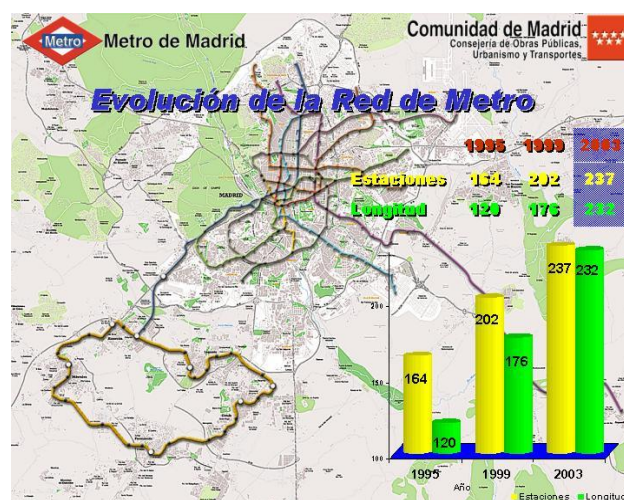

Fig. 1. Extension Plan, 1999 – 2003.

Continuing in the line of modernization of the network, a number of investigation projects have been undertaken in recent years in the field of rolling stock, notably the following:

- A rolling stock Driving and Failures simulator.
- Design and production studies for a Metro coach using composite materials:
- Design of a new rigid catenary profile.
- Design and development of a completely sensorised pantograph.
- Modelling of the rolling stock, and completion of comparative comfort studies.

This article focuses on this last point.

Of note are the multibody simulation models for the completely new 7000 and 8000 series, the former incorporating an articulated bogie, completely new in our operations.

The development of these models opens up the possibility in the future of deepening understanding of the material's behaviour, enabling us to make specific studies of various parameters (comfort, stability, derailment risk, transmission of vibrations, analysis of derailments, modifications of different bogie parameters, wheel-rail contact, etc.).

All these models were created with a multibody system simulation program called SIMPACK, a tool designed for relatively simple and reliable simulation of any type of mechanism.

These models were also used to perform studies related to the comfort of the rolling stock. The 7000 and 8000 series were compared, to analyse the effects of using the articulated bogie mounted in this rolling stock.

2 MADRID METRO ROLLING STOCK

The following is a description of the main characteristics of each of the vehicles currently running on Madrid Metro's lines:

2.1 Main characteristics of the 2000, 5000 and 6000 Series coaches

- 5000 Series: this vehicle has a frame adapted for mounting on bogies with bail bearing race rather than center pivots. The bogies are single-motor, with longitudinal traction drive, pneumatic secondary suspension and elastic wheels.
- 2000 Series: each drive bogie has two traction motors which are longitudinal and fastened together at the reduction gearboxes, rubber spring primary suspension, pneumatic secondary suspension and elastic wheels, with a disc brake on each axle. The trailer bogie uses helical spring primary suspension, with a connecting-rod guided axlebox, pneumatic secondary suspension and one-piece sound-insulated wheels, with the brake-shoe on the wheel tread.
- 6000 Series: this vehicle is more aerodynamic than the previous ones. The bogie has two longitudinal motors, fastened together at the reduction gearboxes. The bogie frame is H-shaped, open at the ends, with bell shaped rubber spring primary suspension and pneumatic secondary suspension. The wheels are one-piece and sound-insulated.

2.2 Main characteristic of the Series 7000 and 8000 coaches (2003)

- These are broad-gauge vehicles, purchased for the major enlargement of the Madrid Metro network in 2002 and 2003.
- These are continuous trains, with passages for movement between all cars.

- Because of the convenience of reducing the weight of the vehicle structure, the carbodies are made of aluminium, used for both the body structure and the plating, the first time this structure has been used by Madrid Metro.
- On the 8000 coaches, there are two traction motors for each bogie, longitudinal and fastened together and to the reduction gearboxes, in a general design similar to that of the 6000 coaches.
- On 7000 coaches, there are also two traction motors per bogie, but here transversal, in a classical distribution not used by Madrid Metro since the 1000 series coaches. These are articulated bogies, so that its longitudinal beams are able to move in relation to each other which, in theory, should enhance adaptability on curves, crossovers or cant.
- The trains' top speed is 110 km/h.



Fig. 2. The 7000 Coach (left) and the 8000 Coach (right).

2.3 Comparative table

The following table summarises some of the main features of these series of vehicles:

Characteristic	5000 4 ^a	2000 B	6000	7000	8000
Line tension	600V DC	600V DC	600V DC	1500V DC	1500V DC
No. of traction motors per drive coach	2	4	4	4	4
Unit power	840kW	594kW	1200kW	3168kW	1520kW
Composition	M-M	M-T	M-M	M-T-S S-T-M	M-T-M
Gauge	broad	narrow	broad	broad	broad
Total length of unit	36.02m	29.44m	36.18m	108.3m	55.049m
Width of unit	2.8m	2.3m	2.7m	2.8m	2.8m
Total unit weight	59.5Tn	54.2Tn	78Tn	209.3Tn	106.3Tn
No. of seats per coach	32	20	24	33	28
No. of standing places per coach	181	125	167	185	193
Maximum speed	70km/h	65km/h	110km/h	110km/h	110km/h
M-M unit acceleration	0.95m/s ²	0.8m/s ²	1m/s ²	1m/s ²	1m/s ²
Maximum deceleration	1.1m/s ²	1.2m/s ²	1.2m/s ²	1.2m/s ²	1.2m/s ²
Train security system	ATP	ATP, ATO	ATP, ATO	ATP, ATO	ATP, ATO

Table 1. Main characteristics of coaches in all series.

3 DYNAMIC COMPUTER-ASSISTED ANALYSIS

Dynamic computer analysis is an attractive alternative to complex experimental measurements and construction of expensive prototypes, leading to reduced costs. In

general, this approach provides results sufficiently close to reality, once the models are suitably adjusted. Moreover, there are a number of situations in which experimental methods cannot be used, as for example in the reconstruction of accidents.

This project involved the modelling of each of the rolling stock series currently running on Madrid Metro lines. This was done with the mechanical system simulation tool SIMPACK, which made it possible to include in the models various characteristics in addition to those incorporated into general-purpose programs, such as introduction of the friction forces at the point of contact between wheel and rail, wheel lift, rail defects, track layout, etc.

These vehicle models can be used to simulate and analyse their dynamic behaviour and to evaluate running stability, curve negotiation, comfort and derailment risk, and they also allow comparisons to be made among different series of rolling stock.

The results of the simulations and the parametric variation calculations can be considered a powerful tool, making possible a thorough understanding of the role of each of the vehicle's components in the dynamic behaviour of the whole system. This enhanced understanding of the vehicle performance finds an excellent field of application in the process of design and, as well, the procurement of new rolling stock.

4 7000 and 8000 COACH MODELS

The following describes the conception of both models, according to the structure shown in the diagrams:

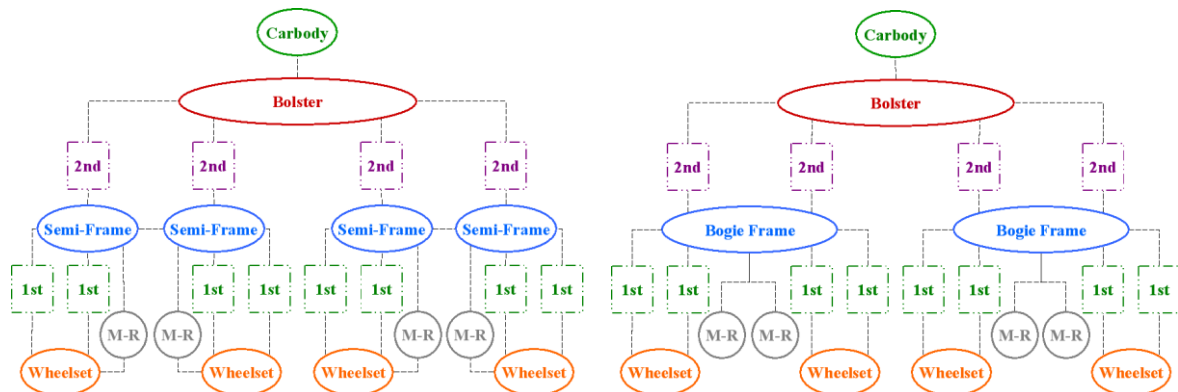

Fig. 3. Diagrammatic representation of the C7000 model (left) and C.8000 model (right)

4.1 Definition of the models

The first step in an analysis of the dynamic behaviour of a multibody system with SIMPACK involves the generation of a model of the real physical system to be analysed, for which it must be broken down into its basic mechanical components such as bodies, joints and force elements.

Railway vehicle models consist of a series of solid rigid elements (carbody, bogies, wheelsets, etc.), joined together by springs and dampers characterizing the vehicle's primary and secondary suspension systems. In addition, in the most general case, a geometric constraint is usually included for each wheel, requiring contact to be kept with the rail.

Generally the data needed to generate the rail vehicle simulation models, such as mass, moments of inertia, the position of the centre of gravity, stiffness and damping of the

various vehicle components, are determined from information supplied by the manufacturer.

In this case, a full set of 2D plans was available, which were used to determine the model's elastic and geometric characteristics, and the mass of each element. On the basis of these plans, a three-dimensional representation was generated with a CAD (AutoCAD) tool and, from there, calculating the remaining inertial properties of each component, such as the position of the centre of gravity, and inertial tensor components.

4.2 Un-sprung mass and Primary Suspension

The un-sprung mass is made up by the wheelsets, onto which the brake discs are pressed (one per axle). The primary suspension is a critical component of the vehicle, determining the performance of the bogie during running, the comfort level, and the construction of the bogie frame.

Because the C7000 series is fitted with an articulated frame, the axlebox is reduced to a simple elastic ring between the axle bearing and the corresponding bogie semi-frame. On the other hand, in the C8000 series, the wheelset ends are pressed into the bearings, in turn housed in the axleboxes, providing support for the rubber springs of the primary suspension placed on each side of the wheelset.

In both cases, the vertical damping originates in the hysteresis of the rubber being used to manufacture the elastic components of this first suspension stage.

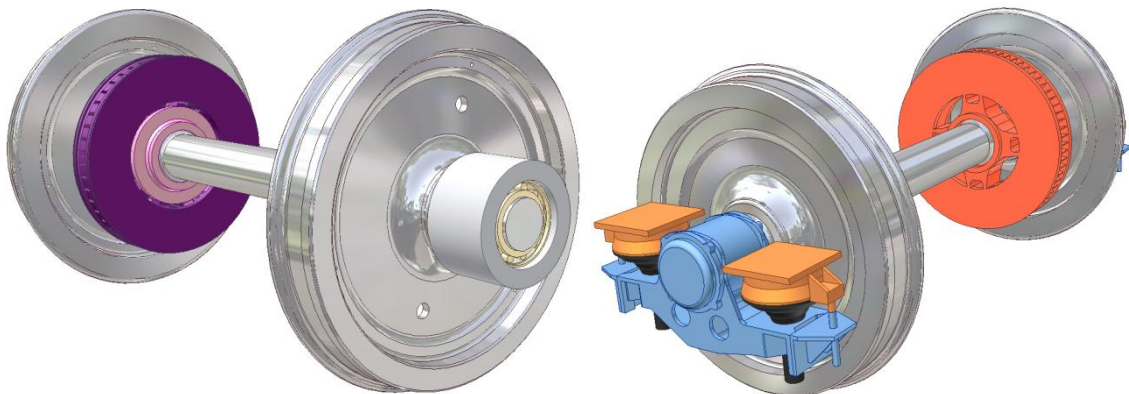

Fig. 4. Un-sprung mass: C7000 (left) and C8000 (right).

The wheelsets and axlebox/bearing (C8000/C7000) were modelled as rigid bodies, both connected by revolution joints. On the other hand, both the elastic ring (C7000) and the rubber blocks (C8000) were defined by springs and dampers connecting the (C8000/C7000) axlebox/bearing to the bogie frame.

In addition, for the C8000 model, a set of vertical stops was defined with contact springs, to limit the primary suspension stroke.

4.3 Sprung mass and Secondary suspension

The sprung mass comprises the bogie frame or semi-frame. The secondary suspension can be considered an elastic connection between the bogie and passenger carbody.

The bogie frame is a structure formed by welded hollow profiles, whose role is to support the other components (suspensions, motors, brakes, guidance,...). It generally comprises two longitudinal side-members and one or two cross-members, forming an H

as in the case of the C8000. The C7000 is a special case of articulated bogie frame, comprising the union of two semi-frames, connected together by ball-and-socket joints.

The secondary suspension plays an important role in sustaining the body, allowing the bogie to turn in relation to the carbody on curves, insulating the carbody from the vibrations generated by the bogie, and transmitting the driving traction force from the bogie to the carbody.

The elastic connection between the bolster and the frame of each bogie comprises two airbags providing elasticity to the system, two transversal hydraulic dampers to damp the lateral vibrations of the carbody, and two traction rods fixed on rubber elements to reduce the transmission of vibrations, designed to transmit the longitudinal drive force to the body. The vertical movements are damped by load losses in the secondary suspension pneumatic system.



Fig. 5. Sprung mass: C7000 (left) and C8000 (right).

The frame and traction rods were modelled as rigid bodies, both connected by universal or cardan joints at the frame connection end, with closed loop constraints, constraining two degrees of freedom at the opposite end (bolster). On the other hand, both the pneumatic airbag and the lateral dampers were defined by means of force elements, the one used for the airbag having special characteristics because it is a pneumatic system.

In addition, a spring has been incorporated at each end of the traction rod to represent the behaviour of the joint silentblock. The model also included contact springs to represent the lateral and vertical bump stops which limit the displacement of the body

against the bogie in case of sudden movements or impacts, or which cannot be absorbed by the suspension.

4.4 Transmission system

In both models, the transmission comprises a two-motor block, coupled to two reduction gearboxes, whose function is transmitting the rotational movement from the motor output shaft to the bogie wheelset. On the C7000, the wheelset coincides with the output axle of the reduction gearbox itself while, on the C8000, there is an intermediate coupling between both components. In addition, the C7000 series reduction gearbox incorporates a vertical connecting rod to the bogie frame, mounted on rubber elements.

The motor, reduction gearbox, and the coupling/connecting rod (C8000/C7000) were modelled as rigid bodies. On the C8000 model, the motor and reduction gearbox are connected rigidly to the frame, while on the C7000, elastic elements were included to represent the silentblocks of the two reduction gearbox connecting-rod joints, and for the connection between the motor and the semi-frame, so as not to render the natural behaviour of the articulated frame rigid.

4.5 Passenger Carbody

This assembly is made up of the passenger carbody with the bolsters and the bearings. Each bolster rests on the secondary suspension pneumatic airbags of each bogie, and is joined to the body by a bearing which allows relative rotation around the vertical axis, making it easier to guide the vehicle on curves.

4.6 Kinematics joints

The following figure shows the final model of both bogies, after each of the components making them up is correctly connected.

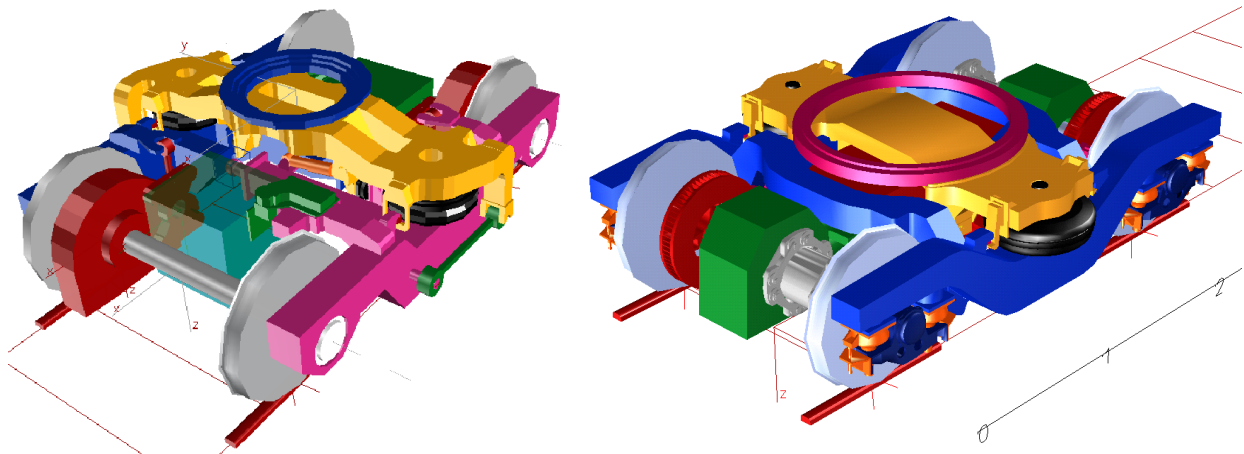

Fig. 6. Final model of the bogie: C7000 (left) and C8000 (right).

5 COMFORT STUDIES

5.1 Comfort Standards

Given the differing sensitivities of the human body to different types of vibration, a variety of treatments must be given to the acceleration to which passengers are subjected,

according to its direction (vertical, transversal or longitudinal), the position of each individual (sitting, standing) and the zone of transmission of the vibrations to the passenger (floor, seat, seatback).

The procedure to be followed for the evaluation of comfort in rail vehicles is contained in ISO Standard 2631 – Part 4, indicating the different positions and orientations at which the measurement must be made of passenger body acceleration, and the weighting filters to be applied in each case, in order to consider the body’s sensitivity to different excitation frequencies.

5.2 Simulations performed

A comfort study was carried out to evaluate the quality of the 7000 and 8000 series vehicles. A set of simulations was run, based on the vehicle models described above, with the introduction of stochastic track irregularities. To define track excitations, four spectral density functions (PSD) were used for track irregularities suggested in China [Ref. 10], related to two different excitation levels, “high” and “low”, both vertically and laterally:

- Irregularity of lateral alignment: $S_A = A_A \cdot \frac{\Omega_C^2}{(\Omega^2 + \Omega_R^2)(\Omega^2 + \Omega_C^2)}$
- Vertical irregularity: $S_V = A_V \cdot \frac{\Omega_C^2}{(\Omega^2 + \Omega_R^2)(\Omega^2 + \Omega_C^2)}$

where $\Omega_C = 0.8246 \text{ rad/m}$ y $\Omega_R = 0.0206 \text{ rad/m}$. And where:

- for low-level disturbance: $A_A = 2.119 \cdot 10^{-7} \text{ m} \cdot \text{rad}$ and $A_V = 4.032 \cdot 10^{-7} \text{ m} \cdot \text{rad}$
- for high-level disturbance: $A_A = 6.125 \cdot 10^{-7} \text{ m} \cdot \text{rad}$ and $A_V = 10.8 \cdot 10^{-7} \text{ m} \cdot \text{rad}$

For each of these four track excitations, the acceleration was obtained at various points (sensors) of the passenger carbody, at speeds of 75 and 110 km/h. The following figure shows the position of some of these sensors, and the name assigned to each, using index ‘P’ for those located at floor level, and ‘A’ for those placed on the seats.

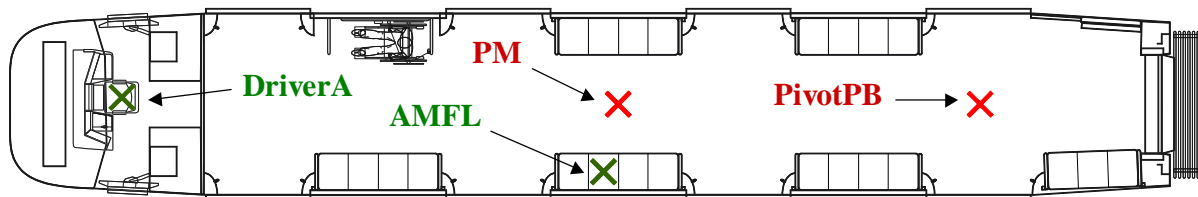

Fig. 7. Nomenclature and position of some of the sensors used.

Finally, for each case studied, a comfort index was obtained in accordance with the specifications in the current regulations. The work made simultaneous use of the ISO 2631 [Ref. 6] and Sperling, W_Z [Ref. 8] indices. By way of illustration, the following table provides a guide facilitating interpretation of the W_Z comfort index [Ref. 11]:

W_Z Index	Interpretation
1	hardly appreciable
2	clearly appreciable
2.5	more pronounced, but not unpleasant

3	strong, irregular, but still tolerable
3.25	very irregular
3.5	extremely irregular, unpleasant; prolonged exposure intolerable
4	extremely unpleasant; prolonged exposure harmful

Table 2. Interpretation of the Sperling index, W_z .

The following are the results of the simulations run at speeds of 75 and 110 km/h, under the action of low-level vertical or lateral irregularities, considered to be closest to the quality of the slab track installed on Madrid Metro lines.

To facilitate the comparative study, the following bar diagrams show simultaneously the Sperling index obtained for each of the vehicles studied (C-7000 and C-8000) in four positions: PM, PivotPB, AMFL and Driver A (see Fig. 11).

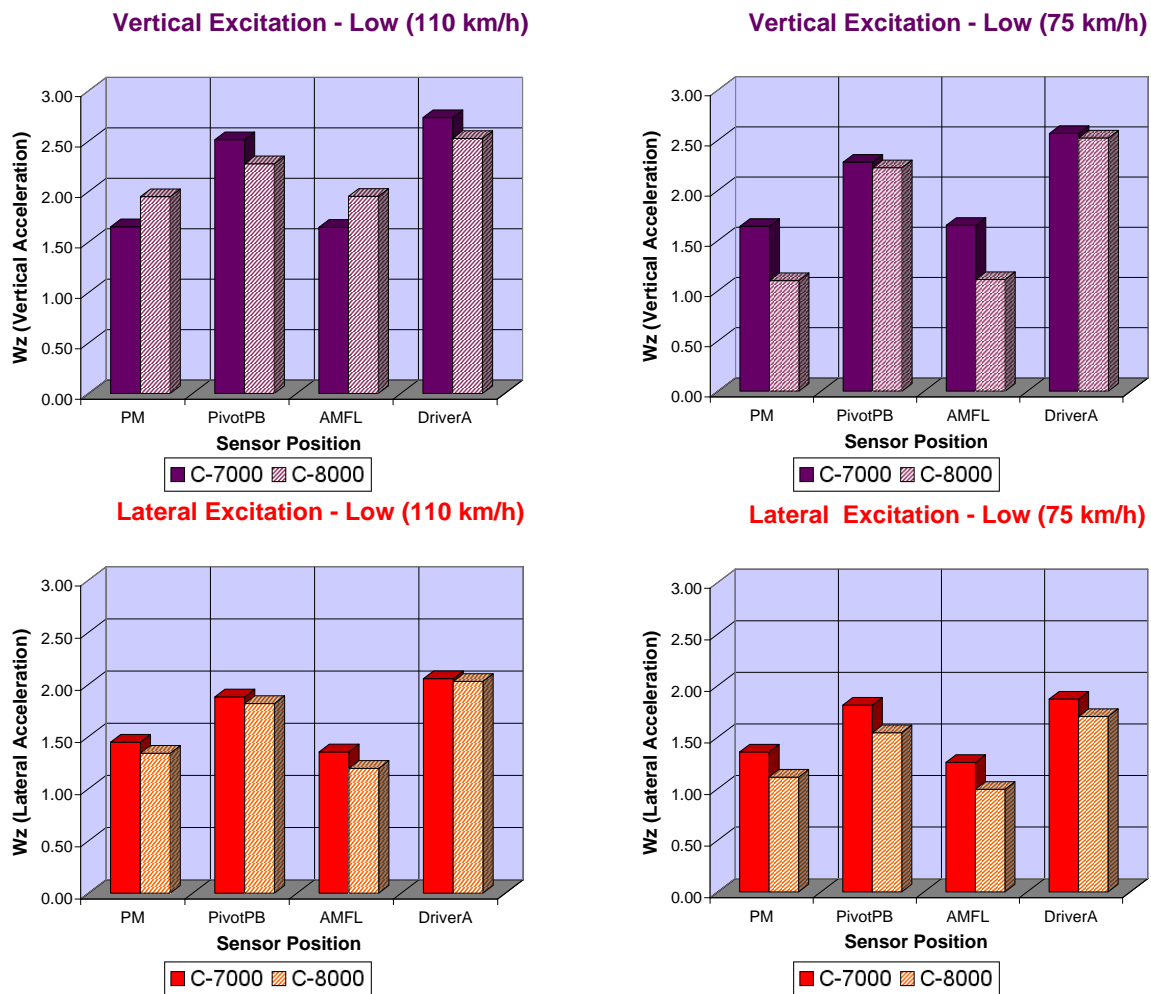

Table 3. Comparative results.

6 CONCLUSIONS AND FUTURE DEVELOPMENTS

From the results obtained, it can be concluded that both vehicles offer satisfactory performance from the standpoint of comfort requirements demanded by this rail administration.

The comfort indices obtained for the 7000 and 8000 series in each case analysed are of the same order of magnitude, both cases offering better performance in the centre of the body (sensor PM), while the least favourable position is the driver's seat (DriverA).

By comparing comfort levels in both series, it can be seen that the 8000 series offers a slight improvement. This difference is most obvious when high levels of track irregularities are simulated (a low level of irregularity has been obtained in the charts shown in Table 3, corresponding to the slab track commonly used at Metro Madrid, even if simulations have been carried out for lesser quality tracks).

Given the similarity of the results, it can be concluded that the use of an articulated bogie, whose main advantage is its high degree of adaptation to the track, does not have any effect on running comfort.

As a possible extension of this comfort study, the possibility is considered of introducing a real track profile measured on Madrid Metro lines, along with the elastic characteristics of the passenger carbody, since it is known that the first flexion modes appreciably affect passenger perception of comfort. It would moreover be of the greatest interest also to include the stiffness and damping characteristics of the seats.

7 REFERENCES

1. M. Melis, F.J. Gonzalez: Ferrocarriles metropolitanos: Tranvías, Metros ligeros y Metros convencionales, 2002
2. P. Carlbom and M. Berg: Passengers, Seats and Carbody in Rail Vehicle Dynamics. *The Dynamics of Vehicles on Roads and on Tracks, Supplement to Vehicle System Dynamics Vol. 37, 2001*
3. M. Götsch and M. Sayir: Simulation of the Riding Comfort of Railway Coaches. *The Dynamics of Vehicles on Roads and on Tracks, Supplement to Vehicle System Dynamics Vol. 37, 2001*
4. P. Carlbom: Carbody and Passengers in Rail Vehicle Dynamics. *Doctoral Thesis, Railway Technology, Department of Vehicle Engineering, Royal Institute of Technology, KTH, 2000.*
5. M. J. Griffin: Handbook of Human Vibration, *Academic Press Ltd, London, 1990.*
6. ISO 2631-4: Mechanical vibration and shock. Evaluation of human exposure to whole-body vibration. Guidelines for the evaluation of the effects of vibration and rotational motion on passengers and crew comfort in fixed-guideway transport systems, *ISO, 2001.*
7. European Prestandard ENV 12299: Railway Applications. Ride Comfort for Passengers. Measurements and Evaluation. *CEN, 1999.*
8. E. Sperling and C. Betzhold: Beitrag zur Beurteilung des Fahrkomforts in Scheinenfahrzeugen. *Glaser's Annalen. Vol 80. pp 314–320. 1956.*
9. O. Polach: Bogie Design for Better Dynamic Performance. Example of a Locomotive Bogie. *European Railway Review, Issue 1, 2003.*
10. L. Zhenggang and M. Hecht: Dynamic Analysis of a New Double Deck Passenger Vehicle with Bogie PW200.
11. J. förstberg: Motion-Related Comfort in Tilting Trains: Human Responses and Motion Environments in a train experiment (SJ X2000). *VTI rapport 449A · 2000.*
12. N. Bosso, A. Gugliotta, A. Somà: Results in Rail Research using SIMPACK. *SIMPACK User Meeting, 2001.*
13. K. Arvind, S. Sanjeev, S. Ajit and R. Mahesh: Improvement in Secondary Suspension of "IRY-IR20" Coach using ADAMS/Rail. *5th ADAMS/Rail User's Conference, 2000.*
14. R. F. Harder: Dynamic Modelling and Simulation of Three-Piece North American Freight Vehicle Suspension with Non-linear Frictional Behaviour Using ADAMS/Rail. *5th ADAMS/Rail User's Conference, 2000.*

15. J. Pombo, J. Ambrósio, L. Figueiras and A. Pereira: Model Development for Applications in Railway Dynamics. *5th ADAMS/Rail User's Conference, 2000.*