

THE APPLICATION OF RAPID PROTOTYPING IN THE DESIGN OF AN UAV

**Barcala-Montejano, M.A.* , Gandía-Agüera, F* , Rodríguez-Sevillano, A.A.* , Crespo-Moreno, J*., Pérez-Álvarez, J*., F.*Gómez-Pérez, J.P.* , Gómez-Pérez, I* ,
* Professors at the UPM (Universidad Politécnica de Madrid), Madrid, Spain.**

Keywords: *preliminary design, UAVs, rapid prototyping*

Abstract

Design and building of UAVs (for civil and military missions) is a field of actuation where the most important Universities, research Centers and Aeronautical designers have dedicated a lot of human effort. In recent years, a team of students and professors (at the Escuela Universitaria de Ingeniería Técnica Aeronáutica, EUITA) have been working on the design and building of an UAV for civil observation. This paper presents the highlights of this project, focussing on the role of rapid prototyping. Furthermore, this paper will present all the features and stages of this engineering project. Also, the current state of technology applied to the process will be presented together with a description of the main difficulties the project has undergone, as a global experience in engineering design and development.

1 Introduction

The concept of “rapid prototyping” (quick prototype generation) has become common in conceptual design processes and prototype design applied to engineering and other fields of the applied sciences. There are entire books devoted to this concept [10]; in some cases with a whole chapter dedicated to aerospace engineering [4].

Rapid prototyping has been oriented, quite frequently, to the design of mechanical elements; prototyping has allow to evaluate design accuracy, complexity of the assembly process, dimensional compatibility, ergonomics based design optimization, and even structural tests, starting from previous analysis carried out

with CAD/CAM software. Also, prestigious universities in the world, in advanced engineering courses, have dedicated their efforts in that sense.

In the aerospace industry, also the concept of rapid prototyping has been used with relative importance. For instance in [24] it is shown the concept of rapid prototyping in complex aeronautical structures manufacturing. It has also been used, as in the case of the authors, to generate airfoils to be tested in aerodynamic wind tunnel; this is the case in presented in [22]. This is oriented to rapid prototyping in the design of launcher vehicles and in the utilization of several materials. We can find applications to build airfoils for low Reynolds numbers tests [12]. The works presented in [9] show some experiences in building wind tunnel airfoils to measure the pressure distributions.

The experience of the authors is in the area of design and construction of UAVs for civil applications and in the design and implementation of robust controllers for UAVs, for both fixed and rotary wings. In the UAV design and manufacturing area, they have directed a group of students to design and build a real UAV; in that sense, the following articles can be looked up [6] and [17]. In the other hand, the results in the design of robust optimal controllers for UAVs are shown in [7]. The application of those controllers to different UAVs flight envelopes is given in [14].

Other universities present similar activities carried by undergraduate students where rapid prototyping machines play an important role [23]. International research centers have also been sensible to this kind of process [22].

Development of real time acquisition and management of on board data plays an

important role. Interesting applications of real time data acquisition systems are addressed in [20]. Other applications as those presented in [5] refer to micro-UAVs. The solutions presented in [11] show the method to integrate several sensors in small rotorcrafts.

Some computational toolboxes have been developed to simulate real time signals related with optimal flight path control [15]. A computational approach to generate real-time and optimal flight trajectories for a flight control experiment is presented. Flight trajectories are computed for hover-to-hover and forward flight maneuvers for both maneuvers and in the presence of obstacles. QoS (Quality of Service) techniques have also been applied to aircraft FMS (Flight Management System) with good results as is exposed in [1].

2 A Review Of UAV Design Stages

2.1 Objectives

This section is essential to have available aircraft parameters to proceed to UAV design. The aim of the project is to design an UAV for civil aerial observation. Once UAV mission has been defined, a wide research analysis of similar airplanes is carried out since, in the initial stage of the project, it is quite common to resort to similar airplanes for estimating some important data of our design. Next, the preliminary sizing is undertaken, taking as a basis weight and wing loading estimations, the latter parameter [18] being essential because it will allow us to study one of the most important elements of the plane: the wing.

2.2 Analysis of similar airplanes

The internet was used as source of information for the study of similar UAVs. First, a group of charts of several airplanes sharing common characteristics (thrust –weight, payload-weight) will be presented.

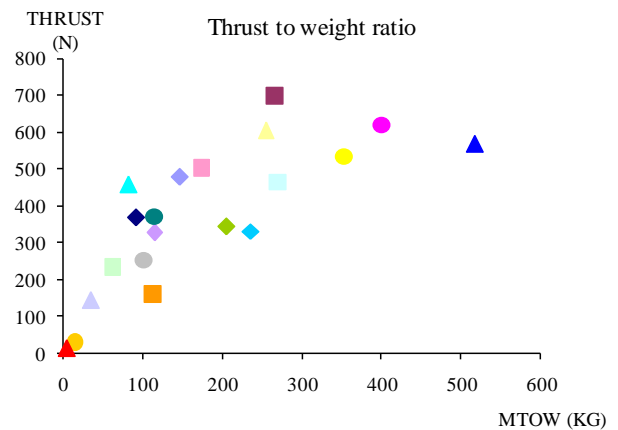

Fig. 1. Weight to thrust ratio

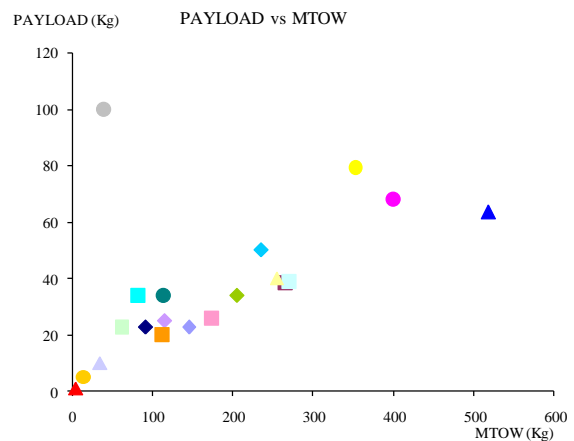

Fig. 2. Payload vs weight

By means of carrying out a comparison with similar planes, on a first approach, parameters were estimated: maximum takeoff weight, payload, range, altitude, and cruising speed.

2.3 Preliminary Sizing and Initial Layout

In the pre-design stage we will point out two main parameters: weight estimation and wing loading estimation.

In this sense the preliminary values selected are: $W_{PL} = 8 \text{ Kg}$, $W_{MTOW} = 30 \text{ Kg}$, $W_E = 13 \text{ Kg}$, $W_F = 9 \text{ Kg}$. These values are selected taking into account the endurance and range requirements, and the payload required for civil aerial observations (digital infrared camera, etc.).

Before calculating the wing area, and, therefore, being able to establish our prototype's wingspan, we needed to calculate the wing loading [3]. This value is conditioned to the

corresponding phase of flight we are going through; as a consequence, we had to determine the wing loading for each of the possible situations.

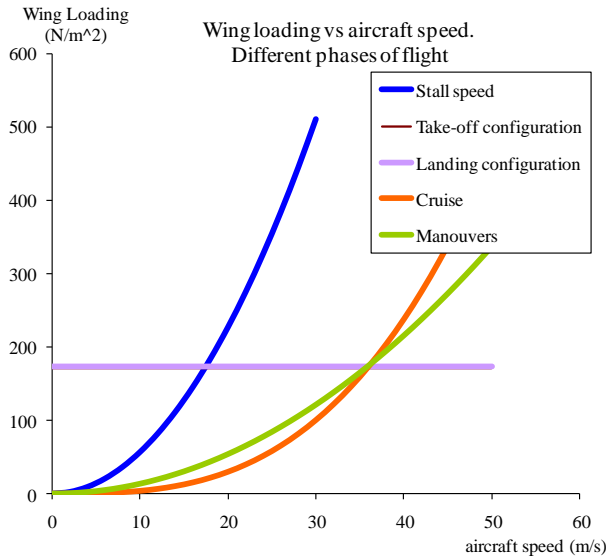

Fig. 3. Wing loading vs speed. Different phases of flight

Figure 3 shows the wing loading variation related with proposed flight conditions. These were considered as final numerical values with respect to estimation of the wing area. In the same way we can see the region of the wing area which verifies all different conditions and the final estimated wing loading numerical value in that region.

Once all the preliminary sizing data had been determined, the following stage in the project was design the aircraft's layout. One of the first tasks carried out in the design process was to design the fuselage. Figure 4 shows a 3D view of the initial configuration of our design.

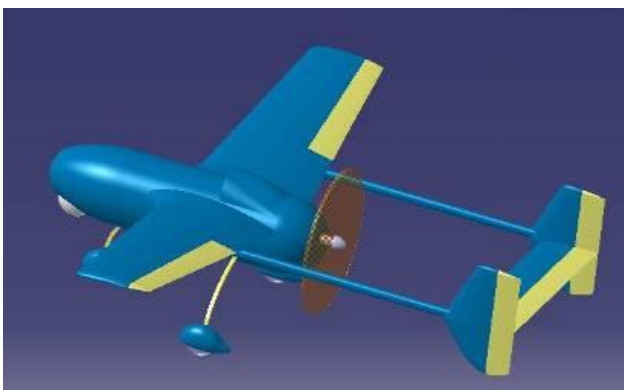

Fig. 4. Initial configuration

2.4 Aerodynamic Analysis and Static Load Tests

The following stage in the project, after determining the preliminary configuration, was to calculate all aerodynamic features and the aircraft's performance.

To complete all these steps, a sound analysis of the most important elements of the aircraft had to be done, from the geometric and the aerodynamic points of view.

Figure 5 shows the obtained results. Here is represented the drag polar curve in the following flight phases: cruise, landing and takeoff configuration.

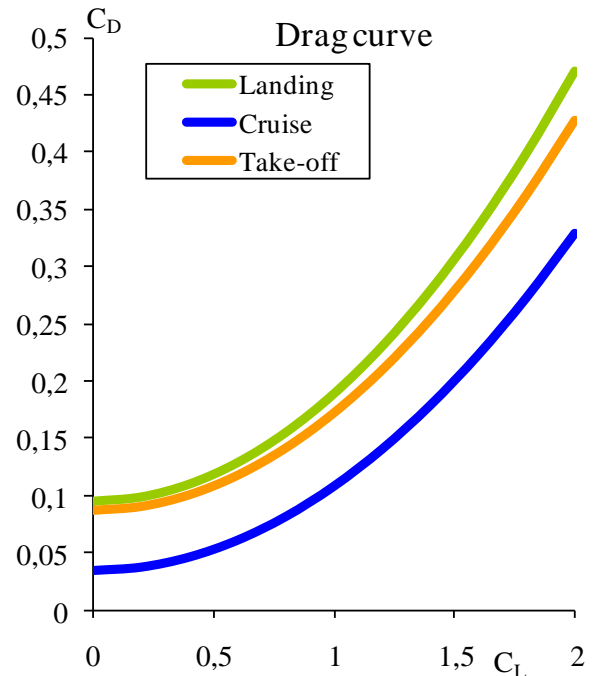

Fig. 5. Drag polar

Some theoretical analysis was performed to determine the available power. Figure 6 shows the results for different altitudes. The intersections between available and required power curves determine the flight envelope from different weights (figure 7).

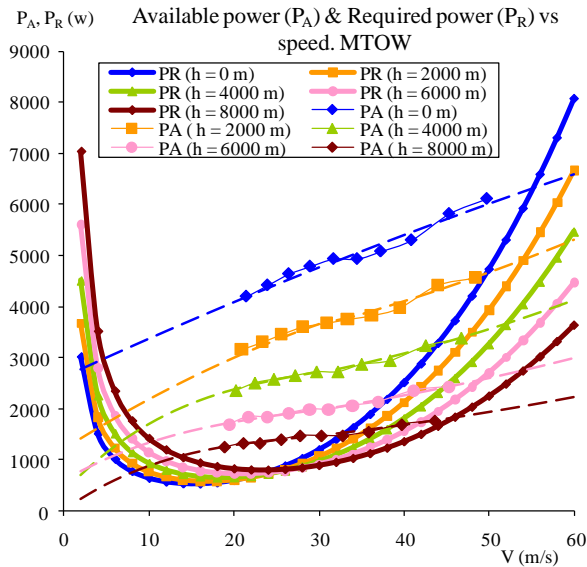

Fig. 6. Available & required power vs speed

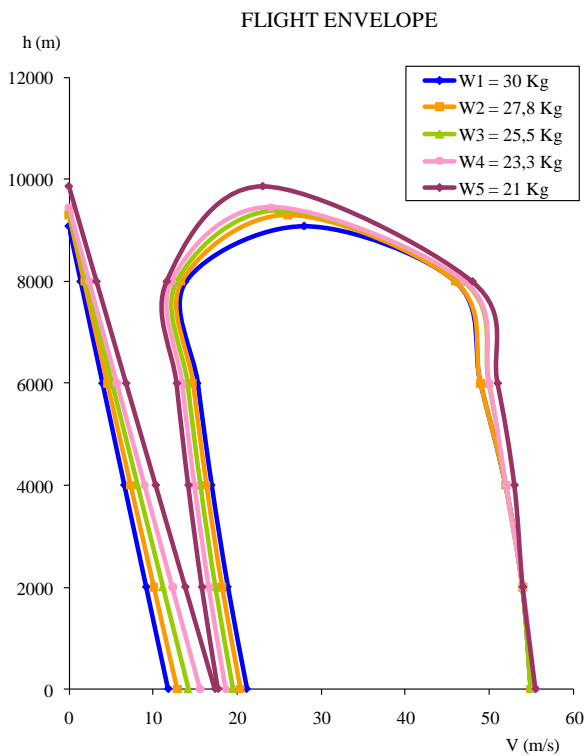

Fig. 7. Flight envelope

Some aerodynamic tests were performed in our wind tunnel. Figure 8 presents the half model used inside the wind tunnel where the aircraft was tested.



Fig. 8. Wind tunnel tests model

After studying of UAV performance, we proceeded to check dynamic and static stability, together with the aircraft control characteristics. Before doing structural analysis, we needed to determine the maneuver diagrams and the gust diagrams, as is shown on fig. 9.

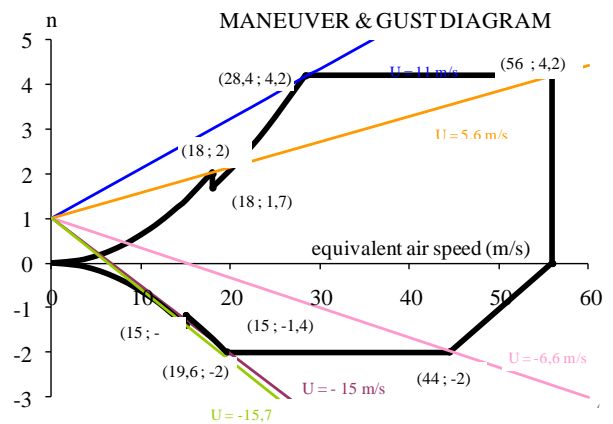

Fig. 9. Maneuver diagram & gust diagram

2.5 Static Load Test

Once the study of the airplane from the aerodynamic point of view was completed, we had to carry out a basic structural study. Before constructing the final prototype and as an essential part of the whole project, we carried out a series of test at our aerodynamic laboratory. We also checked the most critical structural elements by means of static load tests.

The following pictures show one stage of the static loading test. In this stage, we load the primary longueron of the wing until its collapses.



Fig. 10. Loading tests until crash

Another essential part of the static tests was the first engine running together with propeller-engine coupling.



Fig. 11. Propeller-engine first run

3 Building the Airplane

After we concluded the stage corresponding to the essential preliminary calculations we moved forward to the detailed designed and manufacturing stages. A global designed was developed and we had to define materials, joining elements and fasteners. Important phases of the UAV design are shown on next figures.

We also include some comparisons between initial design of the most important elements of the aircraft and the final one manufactured.

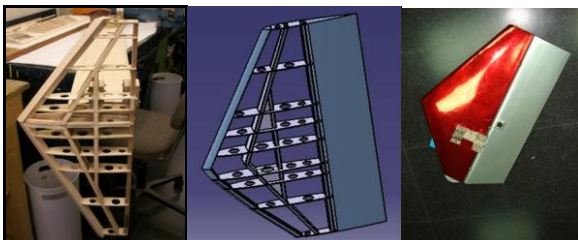

Fig. 12. Comparison between design and final mounting. Fin

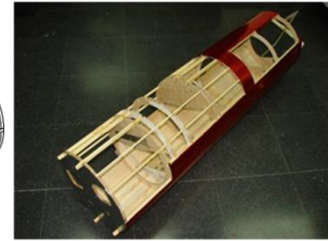
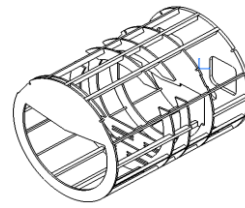

Fig. 13. Structural design of the fuselage



Fig. 14. Final result

4 Using Rapid Prototyping

4.1 Rapid Prototyping Equipment

Within the framework of the UAV design project, described in the previous chapter, the design of a rapid prototype generation process was addressed for design and build of some important elements of the UAV.

Some covers and aircraft fairings are designed like surfaces whose geometry is quite difficult to build by other methods, besides the obvious advantage of speed and versatility of assembly.

Rapid prototyping is a technology that enables the production of models and prototypes directly from 3D solid model generated in the CAD system.

Unlike manufacturing processes that remove material from the original part to obtain the desired model, rapid prototyping systems produce the piece from the additive union of liquid, layer by layer, starting from cross sections of the piece obtained from the 3D model. Rapid prototyping machines (printers) produce pieces in plastic, wood, ceramics or metals.

4.2 Preliminary Design

As an example of this, one of the elements manufactured using this technique is shown in figure 15: the UAV's tail-boom fairing.

Once both the forward and aft part of the tail-boom fairing have been designed, it is the moment to join them. Tangential conditions between the forward and aft zones have to be kept so that transition is as smooth as possible, hence avoiding wind boundary layer separation while flow moves over the fairing. Figure 15 shows the final resulting surface, as a result of joining the forward and aft parts of the fairing.

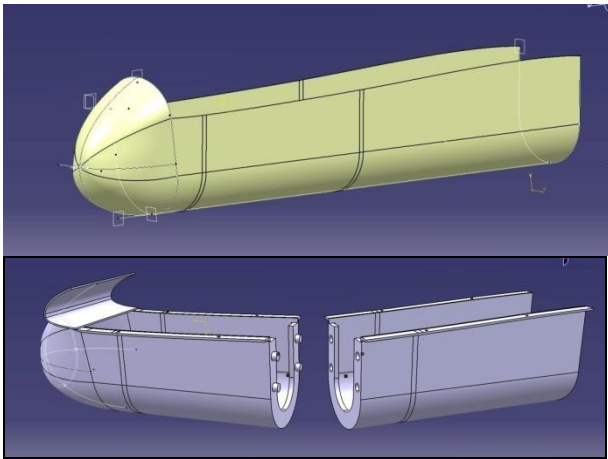

Fig. 15. Preliminary design and two parts final assembly



Fig. 16. Prototype IV manufacturing process. Fairing, placed and fixed onto wing

5 Tests Description

Inside the framework of the UAV design project, described in the previous chapter, the design was addressed of a rapid prototype generation process for wind tunnel tests (see [8]) of the UAV airfoil.

The main objective was to compare CFD and wind tunnel results with real data obtained from flight tests.

Two different models were built to perform wind tunnel tests: the first one (depicted in fig 17) equipped with pressure holes, and the second one prepared to obtain force data (lift, drag and pitching moment).

The wing was of rectangular planform with a span $b = 0,457\text{m}$ (equal to the wind-tunnel width), and a constant chord $c = 0,2\text{ m}$. The maximum relative thickness was $t/c = 0,15$.

The wind-tunnel was an open jet low speed facility (Plint blower tunnel). The test section was a square $0,457\text{m} \times 0,457\text{m}$, and had a length of 1.2m . Boundary-layer correction is achieved by using corner fillets that extend along the contraction cone and the working section. The mean turbulence level into test section is less than $0,5\%$.

5.1 Airfoil Results Analysis

We are going to describe the differences between the computational results ($k\omega$ -SST turbulence model) and wind tunnel results:

- Regarding the lift, the maximum lift coefficient predicted by the computational model was 16% higher. According to previous experiences, the highest angle of attack with reliable results is 16° . Nevertheless, the stall angle of attack obtained in both methods is 15° .
- Using the computational results, we can see that the airfoil stall is progressive starting from the trailing edge. The linear zone of the C_L curve vs. alpha match perfectly the theoretical model, with -3.2° for zero lift angle of attack and -3.4° the value obtained in the experimental C_L vs. alpha curve.
- Regarding the drag, the differences are important.
- In order to improve the results of the pressure distribution along the airfoil, we decided to make a new prototype B with a larger number of pressure holes, in particular in the leading edge where the results are more interesting.

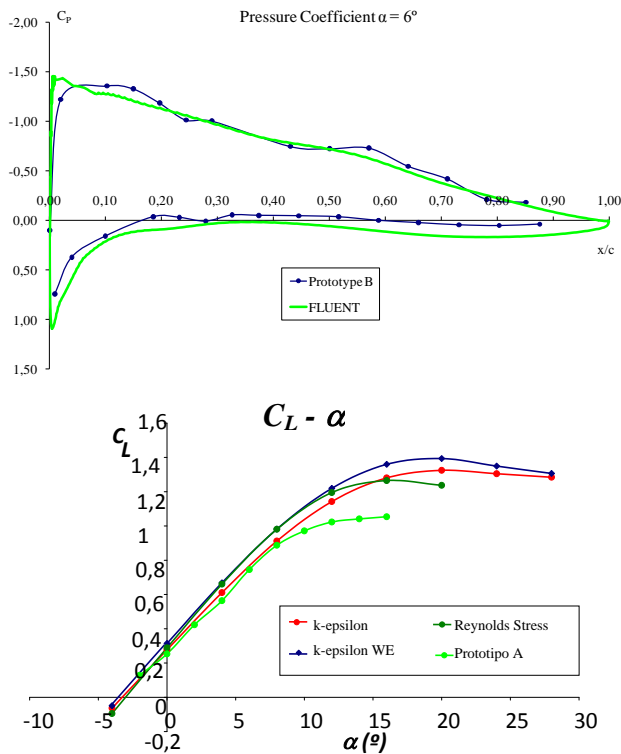

Fig. 17. Comparison between wind tunnel results and computational ones. Pressure distribution and Lift coefficient comparison.

5.2 Flight Tests Analysis

For the flight tests campaign [8], flight data was recorded using the standard UAV sensors. They were sent to ground station using the UAV telemetry system. Data received were stored in an excel file. Data collected included: linear acceleration in three axes (body axes) ground speed in three axes, true speed, yaw, pitch and roll angles, the three angular speeds, control surface deflections, among others.

6 Real Time Data Acquisition

One of the challenges of this Project was focused on the process of data acquisition of the UAV on board sensors data. On board data are given by on board sensors, mainly related with the following parameters:

- Power plant temperatures.
- Engine speed.
- External temperature.
- Static and total pressure.
- Level of fuel.

- Stall sensor.
- Data acquisition system temperature.

In the development phase, LabVIEW software together with a data acquisition system were used to simulate all sensor reading and to perform the mathematical process related with each one. The aim is to perform a real time data acquisition on board as a preliminary phase for the developing of a flight automatic system.

The hardware used is based on the CompactRIO (National Instruments) platform. This hardware and the LabVIEW software, form the rig to perform ground tests. This test platform is set up in the Aerodynamics Laboratory of the School for Aeronautics of the Universidad Politécnica de Madrid (UPM). In this laboratory were developed the test instrumentation and were performed the UAV on board sensor simulations.

Once the sensor simulations were developed and validated, the following objective was to include in the project the wireless communication. The wireless communication between UAV and a ground station is based on a radio-modem. The radio-modem is in charge of sending and receiving data between UAV and ground stations. The communication link is full duplex, allowing to full and real time control of the UAV.

This initial phase concluded with the validation of on board data in the ground station by means of integrity data checks to avoid errors in the downlink process. The following phase is focused on the development and implementation of an automatic data acquisition system based on the know-how obtained from the development phase.

7 Conclusions

The fairing total cost estimate will depend on the price of the supplies and the quantities of the material used. Fairing total costs is around 400 euros, which is quite an important expense. Should other materials be used, such as wood or extruded polystyrene foam (XPS), the price would have been lower but the drawback would have been the irreproducibility of the process

since, in such a case, a manual manufacturing method would have been used.

An asset of using this machine for fairing manufacturing is the accuracy in the design reproduction, the not so positive point being the time the design takes using CATIA.

The time needed for parts manufacturing in the 3D machine was 80 hrs. The aim of fairing the tail-boom fitting was successfully accomplished because of CATIA was used for the design and the “rapid prototyping machine” was later used for manufacturing.

The material used for manufacturing the fairing was quite costly, but the quality of the product is very high. The use of the new material in the machine results in the parts, obtaining a high value of stiffness compared to the other components manufactured for the UAV by means of rapid prototyping.

Preliminary results on flight tests and wind tunnel testing, were both disappointing. This led to a complete revision of the test procedures, introducing several improvements:

- A precise definition of the airfoil coordinates in the modeling software (CATIA, SolidWorks) has to be taken into account. If the number of points (in both lines of the airfoil) is inadequate the solid generation in the 3D printer would present irregularities affecting the experimental results.
- For improved testing of airfoils, a new test chamber for the wind tunnel was built. The new chamber allows test angles of attack above 45°.

Taking into account this changes and considerations, a new group of tests are being performed. Preliminary results show that test results have improved greatly.

The on board data acquisition system developed has been validated and the data transmitted via radio-modem verified. This development phase leads to the next one, based on integration on board the UAV of a similar system to perform the same functions. The selection of the LabVIEW and CompactRIO (National Instruments) has been considered as the best one, to obtain full compatibility of the sensors with the data acquisition system. At same time, the wireless communication link has

been validated and taken as platform for the future on board system.

8 Acknowledgments

We would like to thank to the professor Juan Manuel Holgado Vicente his time and support in the preparation of this paper. Also the contributions of students have been important in the drafting of this paper, specially the efforts of David Arribas Soto.

9 References

- [1] Abdelzaher, T. F., Atkins, E. M., & Shin, K. G. (November 2000). QoS Negotiation in Real-Time Systems and Its Application to Automated Flight Control. *IEEE Transactions on Computers*, vol. 49, nº 11.
- [2] Anderson, J. D. (1995). *Computational Fluid Dynamics, the basics with applications*. USA: Mc.Graw-Hill Book Company.
- [3] Barcala, A., & Gandía, F. (1995). *Aerodinámica y Mecánica de Vuelo: Parte II*. Madrid: Fundación General de la Universidad Politécnica de Madrid.
- [4] Blake, P., & Baumgardner, O. (1992). Texas Instruments: An aerospace case study. En P. F. Jacobs, *Rapid prototyping & manufacturing: fundamentals of stereolithography* (pág. 434).
- [5] Ettinger, S. M., Nechyba, M. C., Ifju, P. G., & Waszak, M. (2003). Vision-guided flight stability and control for micro air vehicles. *Advanced Robotics*, vol. 17, nº 7, 617-640.
- [6] Gandía-Aguëra, F., Rodríguez-Sevillano, A. A., Barcala-Montejano, M. A., & Pérez-Álvarez, J. (2008). The design and building of an UAV: an actual engineering project for student cooperative work. *International Technology, Education and Development Conference (INTED)*. Valencia, 3-5 March.
- [7] Gómez-Pérez, J. P., López-Otero, J., & Monteagudo, A. (2006). Robust Controllers Design Strategies For Unmanned Airships. *ICAS*. Hamburg 3-8 September.
- [8] Gómez-Pérez, J. P., Rodríguez-Sevillano, A. A., Gómez-Pérez, I., Gandía-Aguëra, F., & Barcala-Montejano, M. A. (2009). Airfoil Rapid Prototyping for UAV Aerodynamics Modelling, Wind Tunnel, Simulation and Flight Test. *EUCASS*. Versailles.
- [9] Heyes, A. L., & Smith, D. A. (2004). Rapid Technique for Wind-Tunnel Model Manufacture. *Journal of Aircraft*, 41 (2), 413-415.
- [10] Jacobs, P. F., & Reid, D. T. (1992). *Rapid prototyping & manufacturing: fundamentals of stereolithography*. Computer and Automated Systems Association of SME.

- [11] Kim, H. J., & Shim, D. H. (2003). A flight control system for aerial robots: algorithms and experiments. *Control Engineering Practice*, 11, 1389-1400.
- [12] Landrum, B., Beardt, R. M., LaSar, P. A., & von Sprecken, N. (1997). Evaluation of stereolithography rapid prototyping. Aerospace Sciences Meeting and Exhibit, 35th, Jan 6-9. Reno, NV: American Institute of Aeronautics and Astronautics.
- [13] Lin, C.-F. (1991). Series in Advanced Navigation, Guidance and Control and Their Applications. *Modern Navigation, Guidance, and Control Processing*. Englewood Cliffs, New Jersey: Prentice Hall.
- [14] López, J., Gómez-Pérez, I., Gómez-Pérez, J. P., & Dormido, R. (2006). Development of an UAV Full Envelope Flight Control System. EURO UAV. Paris, 6-8 June.
- [15] Milam, M. B., Franz, R., & Murray, R. M. Real-time constrained trajectory generation applied to a flight control experiment.
- [16] Raymer, D. P. (1992). *Aircraft Design: A Conceptual Approach*. Washington, DC: American Institute of Aeronautics and Astronautics, Inc.
- [17] Rodríguez-Sevillano, A. A., Gandía-Agüera, F., Barcala-Montejano, M. A., & Pérez-Álvarez, J. (2008). The design of an aircraft: using the final research projectwork to develop multidisciplinary skills and general competences in engineering studies. *International Conference on Engineering and Mathematics (ENMA)*. Bilbao, 3-5 July.
- [18] Roskam, J. (1985). *Airplane Design*. Part I, II, III, IV, V, VI, VII. Kansas: Roskam Aviation and Engineering Corporation.
- [19] Salcedo, S., Monge, F., Palacios, F., Gandía, F., Rodríguez, A., & Barcala, M. (2006). Gurney Flaps and Trailing Edge Devices for Wind Turbines. EWEC. Athens: EWEA.
- [20] Saripalli, S., Montgomery, J. F., & Sukhatme, G. S. (May 2002). Vision-based Autonomous Landing of an Unmanned Aerial Vehicle. *Proceedings of the 2002 IEEE International Conference on Robotics & Automation*. Washington DC.
- [21] Springer, A. (1998). Evaluating Aerodynamic Characteristics of Wind-Tunnel Models Produced by Rapid Prototyping Methods. *Journal of Spacecraft and Rockets*, 35 (6), 755-759.
- [22] Springer, M. A. (1998). Application of Rapid Prototyping Methods to High-Speed Wind Tunnel Testing. NASA / TP-1998-208396. NASA. Marshall Space Flight Center.
- [23] Stamper, R. E., & Decker, D. L. (2000). Utilizing rapid prototyping to enhance undergraduate engineering education. *Frontiers in Education Conference, FIE 2000*. 30th Annual. Kansas City, MO, USA.
- [24] Thomas, C. L., Gaffney, T. M., Kaza, S., & Lee, C. H. (1996). Rapid prototyping of large scale aerospace structures. *Aerospace Applications Conference* (págs. 219-230). IEEE.

Copyright Statement

The authors confirm that they, and/or their company or organization, hold copyright on all of the original material included in this paper. The authors also confirm that they have obtained permission, from the copyright holder of any third party material included in this paper, to publish it as part of their paper. The authors confirm that they give permission, or have obtained permission from the copyright holder of this paper, for the publication and distribution of this paper as part of the ICAS2010 proceedings or as individual off-prints from the proceedings.