

Sailing Yacht Rudder Behaviour

R. Zamora-Rodríguez¹, Jorge Izquierdo-Yerón¹, Elkin Botia Vera¹

¹ Model Basin research Group (CEHINAV¹)
Naval Architecture Department (ETSIN)
Technical University of Madrid (UPM)

Abstract

Benefits in a racing sailboat are considered by means of Velocity Prediction Programs (VPP) that includes the stability and aero-hydrodynamic characteristics of the boat. Appendages forces calculations are important to know their hydrodynamic characteristics when they work jointly. In the ETSIN towing tank, some tests have begun to measure hydrodynamics forces in each appendage that will allow evaluating the distribution of forces in different conditions of navigation as well as for deepening in the interactions between hull, keel and rudder. The project is complemented with a numerical analysis of the problem with a commercial viscous code (CFX).

Resumen

Las prestaciones de un velero de regatas se estiman por medio de los Programas de Predicción de Velocidad (VPP) que incluyen las características de estabilidad y modelos aero e hidrodinámico del barco. Para el cálculo de las fuerzas en los apéndices es importante conocer sus características hidrodinámicas cuando trabajan conjuntamente. En el Canal de Ensayos de la ETSIN se ha iniciado una serie de ensayos para la medida separada de las fuerzas hidrodinámicas en cada apéndice que permitirá evaluar el reparto de fuerzas en diferentes condiciones de navegación así como profundizar en las interacciones entre carena, quilla y timón. El proyecto se complementa con un análisis numérico del problema con un código comercial de tipo viscoso (CFX).

Index

1	Introduction.....	2
2	List of Symbol	2
3	Towing tank methods.....	3
3.1	The approach.....	3
3.2	The model	4
3.3	The Measurement Setup.....	5
3.4	The Measurement Program.....	6
4	Results.....	6
4.1	Bare Hull Resistance	6
4.2	Rudder Resistance	8
4.3	Side Force	9
4.4	Downwash.....	10
5	Numerical Modelling	11
6	Conclusions	13
7	Acknowledgements	14
8	References	14

¹ <http://canal.etsin.upm.es/>

1 Introduction

The design of airfoils hydrodynamics has a fundamental character in the scope of the Naval Construction. From rudders and stabilizing fins in conventional ships, fast boats airfoils to rudder, keel, fins or bulbs in sailing race yachts. There is an ample field of use in naval applications with and without influence of the free surface where the drag and lift on the appendages have since long been an area of extensive research.

In their later publications on "Keel-Rudder Interaction on a Sailing Yacht" and "Further Analysis of the Forces on Keel and Rudder of a Sailing Yacht" (ref [1], [2]) Keuning et al. realized an study of the keel influence on the rudder. They are continuing the works started before by Keuning where an assessment method has been presented for determining the force distribution in yaw and sway over the hull, keel and rudder (ref [3], [4]). The development in the design of sailing yachts has a considerable extend taken place in this area animated by the variety of competitions and the increase of interest for this kind of ships.

In the calculation procedure used for the yaw moment the side forces of the keel and the rudder are important. The distribution however is strongly influenced by the underlying assumptions made in the Extended Keel Method (EKM) introduced by Gerritsma (ref [5]) for calculating the side force on the keel and rudder (and hull) of a sailing yacht. He had very good results for the total side force of the hull, keel and rudder together in the upright condition, indicating that the mayor part of the side force is produced by the appendages, in particular for boats with average to high aspect ratio keels and rudders. The method fails in C_L and C_R prediction due to the different lift contribution between canoe body bow and stern does not consider. Therefore, it is very important to measure appendages forces separately.

Some articles appeared later trying to explain the interaction between the appendages using diverse forms to analyze the problem, from studying the variation of the resistance to seeing as it affected through the wave cuts (ref [6], [7], [8], [9] and [10]). The conclusion in them are that there is a reduction in "free stream" velocity of the incoming fluid on the rudder (since it operates in the wake of the keel) and a reduction of the effective angle of attack on the rudder through the vorticity shed off by the keel caused by the lift generated on the keel, i.e. the downwash.

In order to account for the effect of the keel on the rudder a correction of the effective angle of attack on the rudder of 50% of the leeway angle was suggested by Gerritsma as well as a reduction of the velocity by 10%. Other formulations as those formulated by S. F. Hoerner, ref [11] have also been used.

To investigate these interference effects it was decided to carry out a series of experiments in the ETSIN towing tank. The aim of this experiments are to measure the lift and drag of the three different components of a yacht hull, i.e, the hull, the keel and the rudder, separately under different combinations and conditions in order to determine their mutual interaction, preliminary results are presented in this document.

2 List of Symbol

L	Length
B	Beam
C_L	Lift coefficient
C_D	Drag coefficient
F_n	Froude Number
V	Forward Speed
δ	Rudder Angle
β	Leeway Angle

ϕ	Heeling Angle
λ	Scale factor
C	Canoe body
BK	Bulbed-Keel
R	Rudder

3 Towing tank methods

3.1 The approach

A sailing yacht model, has been equipped with a keel and a rudder, which are both connected to the model by means of separate dynamometers. Keel and rudder are attached to these dynamometers in such a way that the forces acting on them are only absorbed by the dynamometers, and no partly by the hull.. The keel is set in a fixed position, while the rudder is attached in such a way that it is possible to quickly set a positive and negative rudder angle. Leeway and heel are predetermined and fixed while lateral motion is restricted.

Since the speeds at which the tests are done are relatively low (which is caused by the fact that the speed of the model has been scaled according to Froude's scaling laws), there is a chance that the flow around the hull will remain laminar. Especially with the appendages, which have a low "characteristic length" (which, in this case, is the waterline length) this will surely happen. To make the flow around hull and appendages turbulent (the situation which will occur at full scale) turbulence stimulators are attached on both hull and keel. These turbulence stimulators are strips, as is shown in figure 1. There are no turbulence stimulators on the rudder due to the chord in the model is too short and it is influenced by the keel wake.



Figure 1: Turbulence Stimulators on hull, keel and bulb

By taking measurements with a series of leeway angles ($\beta = 0, 2, 4$) applied to the model the side force on the keel could be varied. At each yaw angle the rudder angle δ has been varied with different rudder angles from 12 degrees to starboard till 12 degrees to port. This whole series of conditions has been repeated with 0, 10 and 20 degrees of heel applied to the model.

By interpolation between the tests the rudder angle, at which the side force on the rudder is equal to zero has been determined and comparing this with the leeway angle of the model as a whole, the downwash angle on the rudder could be determined. It should be noted that this downwash angle is therefore the “averaged” downwash angle over the entire span of the rudder.

3.2 The model

The model which has been used for the measurements is a Transpac 52 class, with a higher beam/draft ratio than an America’s Cup class model. The lines plan of this hull is presented in figure 2. For towing tank tests a scaled model was made ($\lambda=5.5$). In this study a bulbed-keel and a rudder is used, but different keels and configurations will be tested in the future. The principal appendages dimensions used for the measures are presented in Table 1 for the keel and rudder and in Table 2 for the bulb.

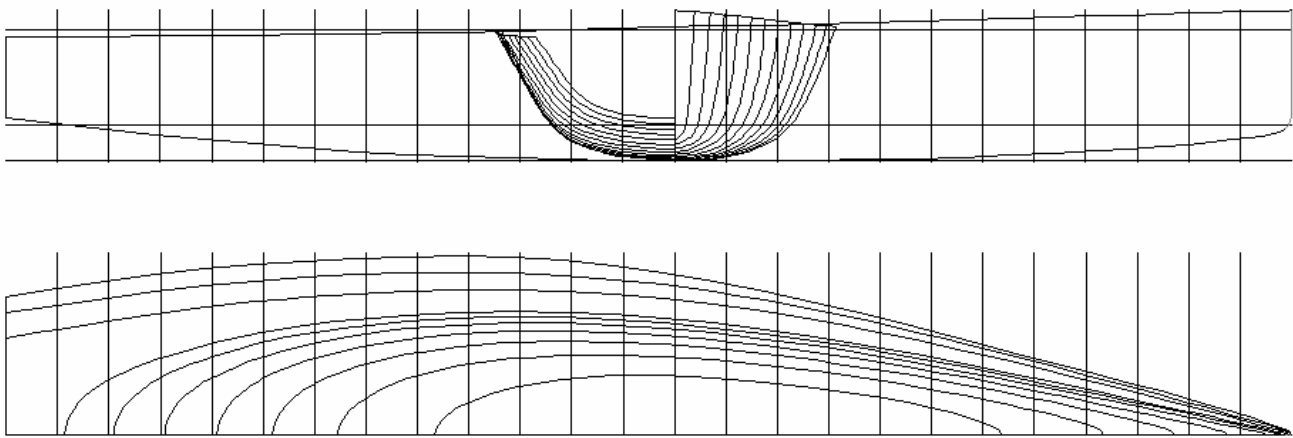

Figure 2: Lines plan of the model hull used for the experiments

		Keel	Rudder
Root chord	C_{root} [m]	0,165	0,091
Tip chord	C_{tip} [m]	0,106	0,024
Lateral Area	A_{lat} [m ²]	0,060	0,033
Wetted Area	S [m ²]	0,120	0,066
Aspect Ratio	AR [-]	3,315	7,217
Span	b [m]	0,449	0,467
Mean chord	C_{mean} [m]	0,136	0,060
Sweepback angle	Λ (°)	5,36	12,16
Thickness/chord ratio	t/c [-]	0,147	0,217

Table 1: Main particulars of the keel and the rudder

Length	L [m]	0,486
Draft	D [m]	0,078
Draft/length ratio	(D/L)	0,185
S	S [m ²]	0,101

Table 2: Main particulars of the bulb

3.3 The Measurement Setup

The tests have been carried out in the towing tank of the ETSI Navales (U.P.M). The towing tank has a length of 100 m, a width of 3.8 m and a depth of 2.2 m. The top speed of the carriage is 3.5 m/s.

The method used is the most frequently in yacht tests. In this method the model is restrained in the amidships position at a pre-determined leeway angle by means of arms fixed to the model fore and aft. These arms are constructed in such a way no vertical or longitudinal forces are exerted on the model. This allows the model freely sink and trim with speed. Lift on the model at speed is measured at each of these arms where they are fixed to the model by means of block strain-gage dynamometers. The arms are fixed to the model through these block gages in a way allowing the model to adopt a determinate heel and leeway angles while the arms remain vertical. Forces are measured according tank axis. The required angle of heel at speed is usually realized by moving a weight transversely along the deck before the run commences, which position is the often fine-tuned to compensate for the change in transverse stability of the model with speed. The resistance of the model, equal to the towing force, is measured in the towing connection between carriage and model, which connecting is also able to accommodate any vertical movement of the model. Ballast weights need to be moved longitudinally between each run to compensate for the fact that the model is not towed from the centre of the resultant aerodynamic force. But in this case the tests have been realized without moving ballast weight in order to calculate forces in the same initial waterlines with and without appendages. A configuration scheme is presented on figure 3 and a photograph of the device is shown in figure 4.

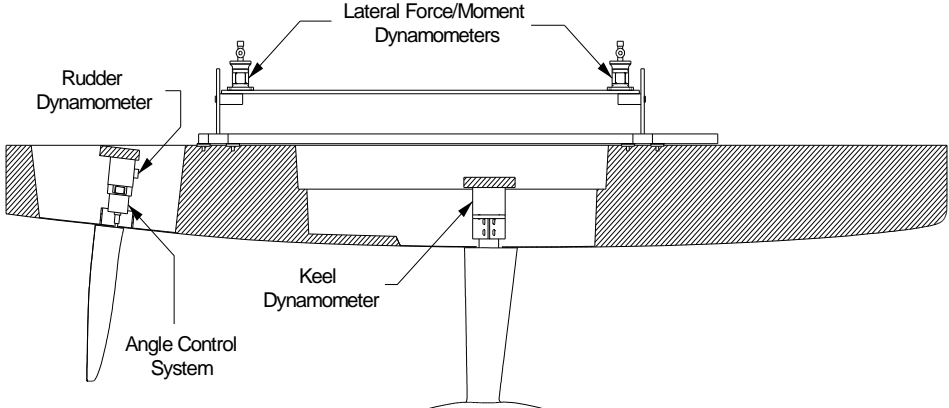

Figure 3: Measurement scheme



Figure 4:

A six-component dynamometer, capable of measuring forces and moments in the x-, y- and z- directions, are used to measure the forces on the rudder. A five-component dynamometer, incapable of measuring z-direction forces is used on the bulbed-keel.

For every run, the model was heeled and yawed as required. Forces are projected in tank reference system in order to measure resistance and side forces. By means of a laser system, model sink and trim are measured during tests. There are three sensors fixed in two ways. Two vertically, there are one forward and the other aft and vertical movements are measured with these. The third is situated longitudinally and it is used to measure longitudinal displacement.

During the tests the following quantities were measured:

- Resistance and side force of the hull as a whole
- The positions of the model in surge, heave, and pitch.
- The forces and moments in -x, -y and -z direction on the rudder and on the bulbed – keel.

3.4 The Measurement Program

An identical series of tests has been carried out with the model equipped in different ways, bare hull, hull + rudder, hull + bulbed-keel and hull + rudder + bulbed-keel. The following conditions have been tested.

- Upright condition. Used for the determination of the total resistance of the hull, bulbed-keel and rudder. The residual resistance of the appendages has been determined in this upright condition in the speed range from $Fn = 0,15$ up to $Fn = 0,6$ (4 kn up to 14 kn)
- Leeway without rudder angle. For two forward speeds ($Fn = 0.336, = 0.420$), leeway angles $\beta = 0^\circ, +2^\circ, +4^\circ$ and heel angle $\phi = 0^\circ, 10^\circ, 20^\circ$ with a fixed rudder angle $\delta = 0^\circ$
- Leeway with varying rudder angle. For two forward speeds ($Fn = 0.336, = 0.420$), leeway angles $\beta = 0^\circ, +2^\circ, +4^\circ$ and heel angle $\phi = 0^\circ, 10^\circ, 20^\circ$ test have been carried out varying rudder angle in 2° between $\delta = -12^\circ$ to $\delta = 12^\circ$ except in test where high angle rudder measurement are not available. In this cases the test were carried out by CFX.
- Rudder performance. To measure the rudder performance on its own without the presence of the bulbed-keel, tests have been carried out without bulbed-keel at two speeds ($Fn = 0.336, = 0.420$) with varying rudder angles between $\delta = -12^\circ$ to $\delta = 12^\circ$ except in test where high angle rudder measurement are not available.

Finally, wind tunnel tests have been carried out to measure appendages resistances without canoe hull influence and some test were realized in the towing tank with Pitot tubes to measure fluid flow velocity in rudder position with and without keel in order to compare results.

4 Results

4.1 Bare Hull Resistance

Tests were carried out for the hull without appendages, with bulbed-keel only, with rudder only and with both bulbed-keel and rudder. By examining the resistance components of this run it is possible to determine the effects each appendage will have on the overall flow around the yacht.

As it were commented previously the total resistance of the model has been measure for the hull in all test and thanks to the bulbed-keel and rudder dynamometers, the resistance of these elements had been measured, and the total resistance could be divided knowing the influence of the appendages.

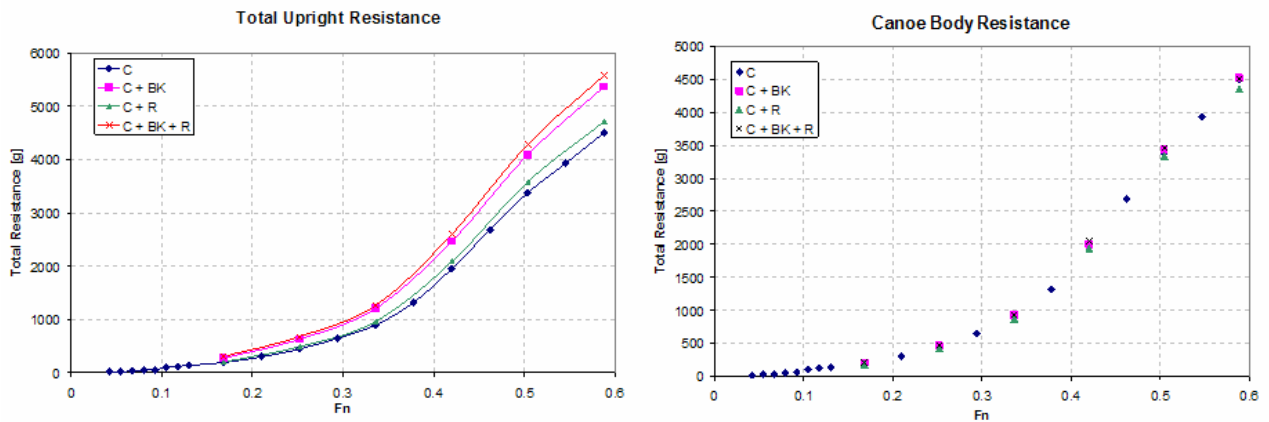

Figure 5: Total resistance (left) and resistance on the hull minus appendages (right)

As anticipated, the resistance is increasing according new elements are added to it. All the results are very similar, but the awaited result was that the most favourable condition will be the bare hull one. Nevertheless, it is observed that it is more favourable when the rudder is introduced, as it is showed on figure 5, probably by the reduction of the stern wave.

Finally, to give some indication about the relative importance of the different resistance components when considering the upright resistance of a sailing yacht hull figure 6 has been set up. In this figure, the relative contribution of the three elements: canoe body, bulbed-keel and rudder as function of the forward speed of the yacht, are presented.

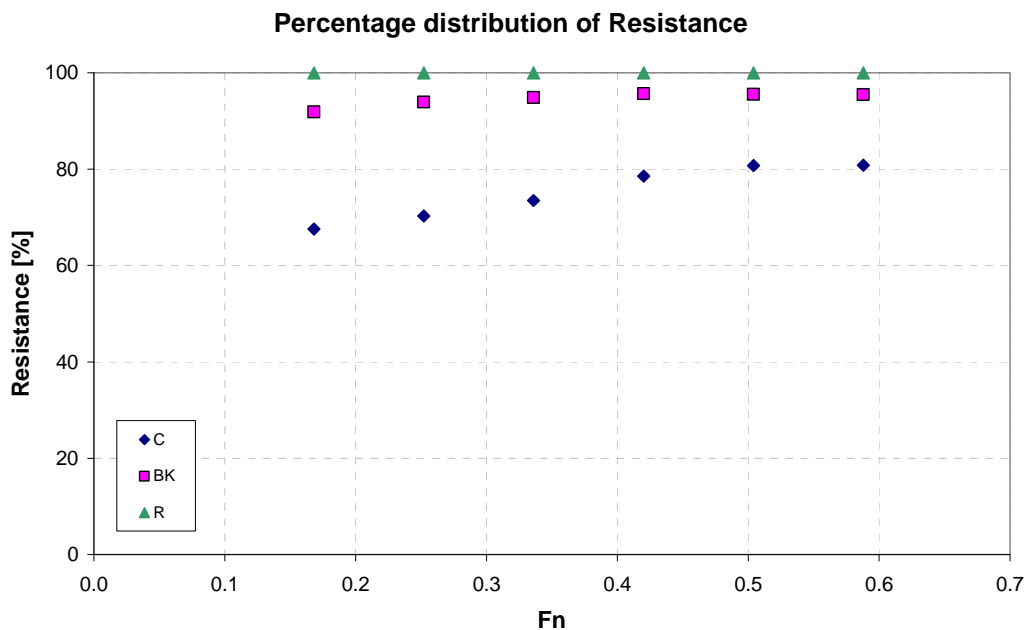

Figure 6: Percentage distribution of Resistance

4.2 Rudder Resistance

The resistance of the rudder in free flow with and without the presence of the bulbed-keel in front of it and the reduction of the velocity in the wake of it was measured. By relating the resistance measured behind the bulbed-keel to the resistance of the rudder measured with no bulbed-keel present a “change” in resistance could be determined. This “change” has to be attributed to the influence of the wake of the bulbed-keel and the canoe body on the rudder.

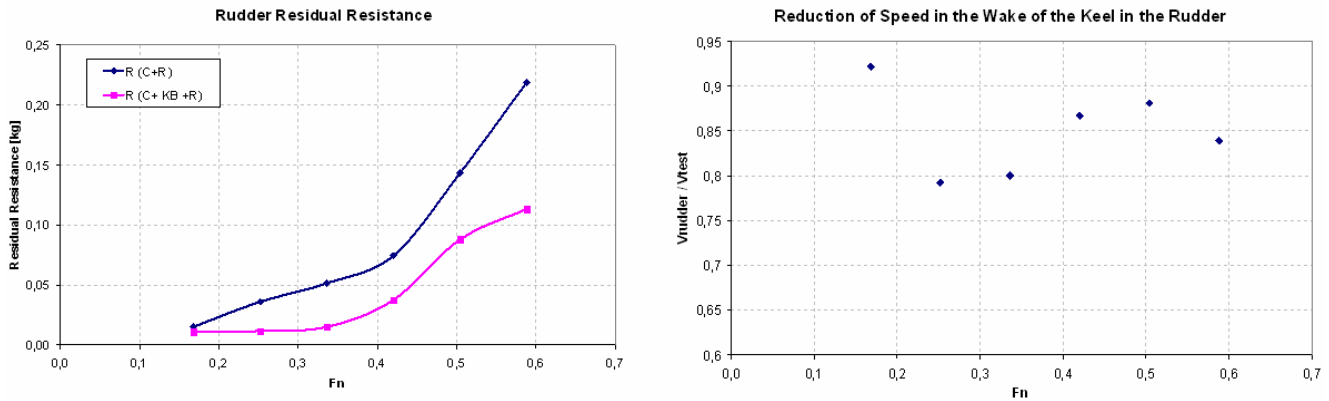

Figure 7: Resistance and Reduction Speed in the Rudder

The smaller residual resistance of the rudder in the wake of the bulbed-keel caused by the diminution of velocity in the wake surely seems clear.

To determine the residual resistance of the rudder its viscous resistance has to be known. This is acquired by calculating the frictional resistance coefficient of the rudder according to the ITTC '57 formulation and using the form factor of the appendages as expressed by the empirical formulations as given by Hoerner, [11]:

$$1 + k_{rudder} = 1 + 2 \left(\frac{t}{c} \right) + 60 \left(\frac{t}{c} \right)^4 \quad \text{Equation 1}$$

The same phenomenon occurs with the total resistance as it is showed on figure 8. This difference of speed could be considered comparing both curves. If C_D on the rudder is constant and proportional to V^2 there will be the following relation.

$$V_R = \left(\frac{R_{R(C+BK+R)}}{R_{R(C+R)}} V^2 \right)^{1/2} \quad \text{Equation 2}$$

The resistance curves are based on the number of Froude and probably the first value could be ignored due to the small value of the measurement.

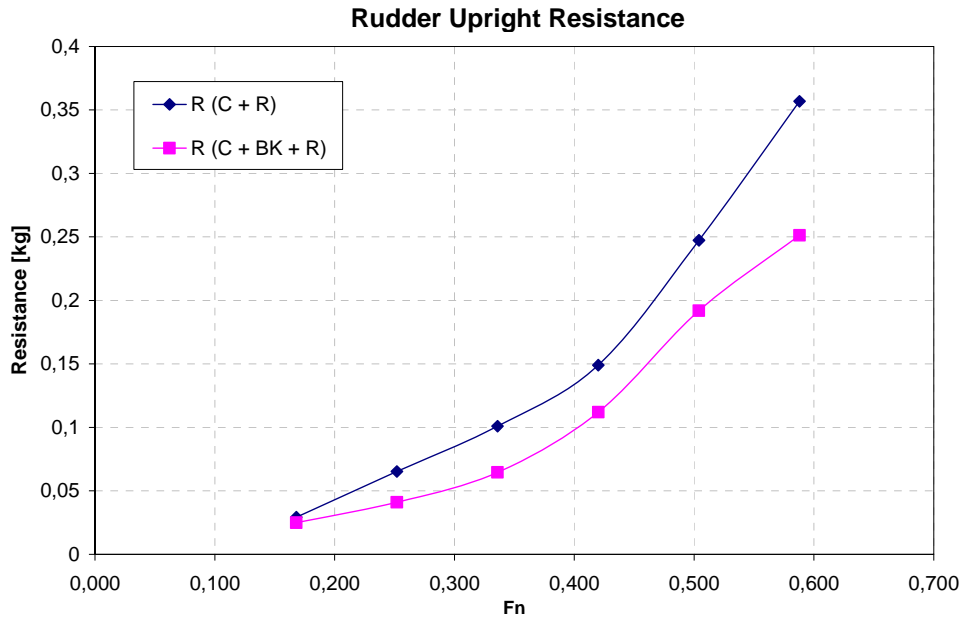

Figure 8: Rudder Upright Resistance

4.3 Side Force

Furthermore, Experiments have been realised in wind tunnel with the rudder model to compare the results with the obtained in the towing tank. The wind speed was approximately 20 m/s the equivalent to assure the same Reynolds of the rudder for a Froude number in towing tank of 0.252. Lift results are shown in figure 11.

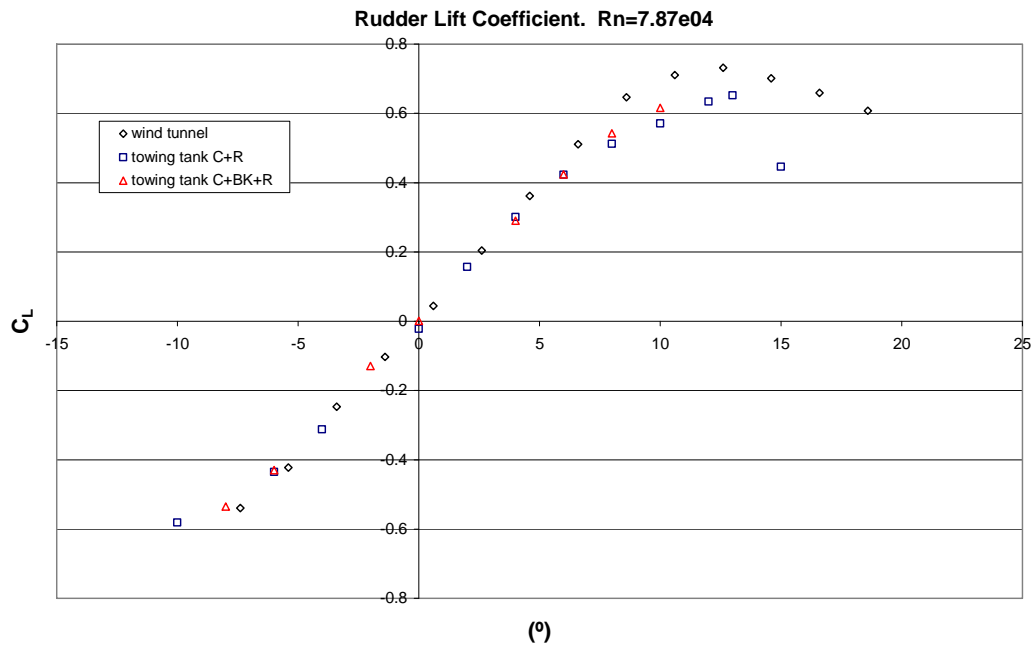

Figure 9 Rudder Lift. Comparison wind tunnel-towing tank

4.4 Downwash

Another interesting effect due to the presence of the keel is the “downwash”. If it did not have modification of the flow, when the boat sails with a leeway and heel angle, the angle of attack of the flow in the rudder would have been $\beta \cos \phi$. This is not the real situation, the flow modifies in the presence of the keel and hull so that this angle is reduced. Following Keuning [2] downwash angle, averaged throughout the rudder span can be calculated looking for the angle of zero lift in the rudder (δ_0)

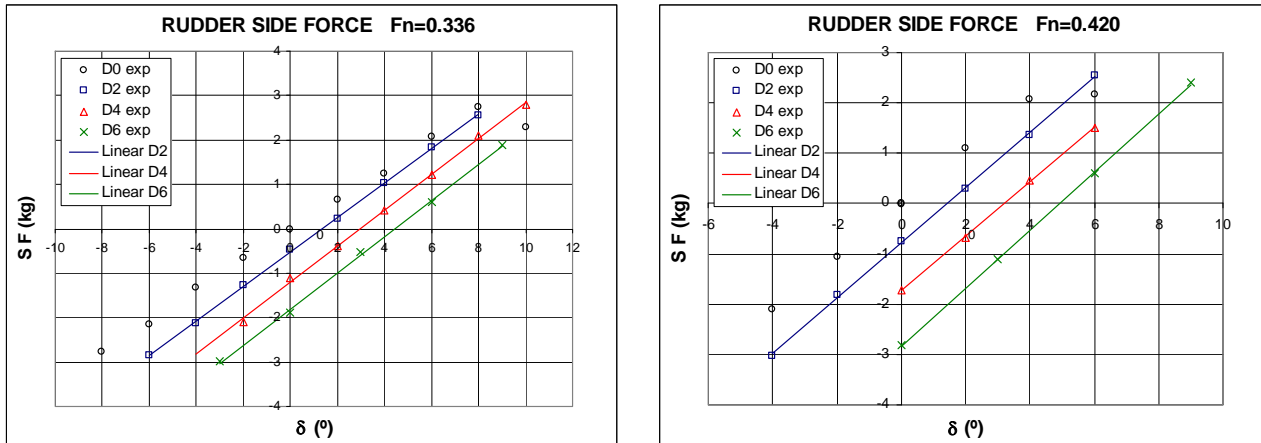

Figure 10: Rudder Side Force. Heel 0°

β (°)	Fn		Fn	
	0.336	0.420	0.336	0.420
	Lift Vanishing Angle (°)		Downwash (°)	
2	1.34	1.42	0.66	0.58
4	2.95	3.19	1.05	0.81
6	4.43	4.90	1.57	1.10

Table 3 Downwash and Lift Vanishing angle. Heel 0°

Van Oosanen [13] recommends a reduction of effective value of the angle of attack of the rudder $\beta \cos \phi$ by half. In table 3 results for heel 0° are found. The values of side force are given in figure 14 (positive rudder angle in weather helm). Results suggest that a reduction of a 50% in the angle of incidence is exaggerated for the tested keel and rudder, probably due to the high aspect ratio of the keel. Another surprising result is that downwash reduces when increasing the speed, which is to say when increasing the load of the keel.

In normal conditions of sailing with heel, rudder capacity of generation of side force is modified. Results of side force for $\beta = 20^\circ$ are presented in figure 11. As can be seen lift force increase with heel in weather helm and decrease in lee helm.

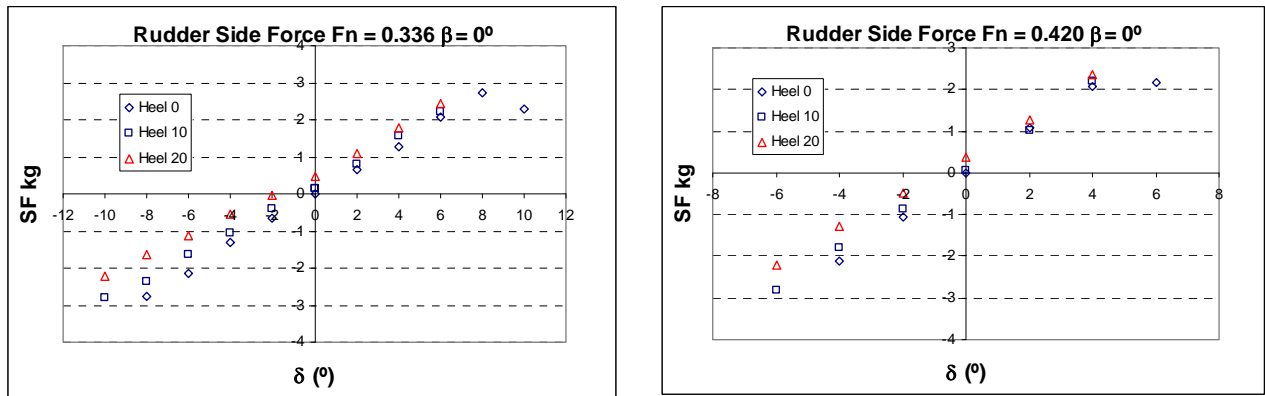

Figure 11: Rudder Side Force with heel

5 Numerical Modelling

Finally, this paper presents results of the computations performed in the ETSIN for the tests evaluated in the towing tank with the RANSE free surface commercial solver CFX. This code was validated before and some of the computational results are validated against experimental data in terms of various global and local quantities [14].

The CFX code is based on a finite volume discretization. The turbulence model used in the calculations was the SST (Shear Stress Transport) model [15], [16] and the volume of fluid method is used to model the free-surface flow. The numerical schemes use higher order cells to satisfy the momentum, pressure and turbulence quantities where each hexahedral cell is further subdivided into eight sub-volumes. A control volume is formed from the sub-volumes surrounding a grid node and a first order finite element basis function is used for each sub-volume. The momentum and pressure are simultaneously satisfied using a coupled solution system. All the numerical equations are solved using algebraic multi-grid acceleration with implicit smoothing. Parallel computation on a 2 processors PC was adopted to reduce the required computational time and increase the number of elements used, in this case 1.8×10^6 .

The tests realized with CFX were bare hull, hull + rudder, hull + bulbed-keel and hull + rudder + bulbed-keel. With CFX is possible to evaluate bulbed-keel and rudder alone in wind (or water) tunnel condition.

All hull calculations presented in this paper were performed with no heel or leeway and the model was set in the control volume just according to the sink and trimmed values (measured in the towing tank) and in equilibrium position. This permits to consider a symmetry plane and working just with half geometry, but a complete geometry has been used because the aim of the study is simulate heel and leeway conditions too.

Dimensions considered for the control volume based on the length of the model (L) can be seen in table 4.

	Canoe body	Appendages
Forward	2L	2L
Aft	6L	5L
Side	1.5L	2L
Below	1.25 L	2L

Table 4: Dimensions considered for the control volume.

A structured mesh based on an O-grid block distribution has been used for the tests. The O-grid meshing technique subdivides selected blocks into a configuration of one central block surrounded by radial blocks.

The boundary conditions for the numerical test were:

- Inlet: it is used where the flow enters into the domain. A condition of normal velocity was introduced and to simulate the turbulence the ratio of 1% (the minimum value) between the turbulent viscosity and fluid viscosity is considered.
- Outlet: It is used where the fluid of the domain goes out and a condition of velocity was introduced in free surface test. While in wind tunnel conditions (keel and rudder alone) an average pressure condition was used.
- Symmetry: This condition was used for the sides of the domain.
- Wall: For the top and the bottom of the domain. It could be used for the sides too. The condition imposed was free-slip. However, for the model, canoe body and appendages, the condition used was no-slip.

The results obtained for the bare hull resistance were good as they are shown when average values of sink and trim obtained on tests were introduced.

Velocity [m/s]	Experimental Res. [gr]	Num. Res with Sink&Trim [gr]	error [%]
1,755	862,90	880,67	2,06
2,193	1878,30	1884,92	0,35
2,632	3205,5	3361,51	4,87
3,071	4294,5	4720,40	9,92

Table 5: CFX Canoe Body Resistance

The appendages have been tested in wind tunnel condition without hull. The results obtained for them were the following:

Velocity [m/s]	Experimental Res bulbed keel [gr]	Num Res bulbed keel [gr]	error [%]
0,877	0,0817	0,0851	4,2
1,316	0,1891	0,1789	5,4
1,755	0,3279	0,3028	7,7
2,193	0,4744	0,4573	3,6
2,632	0,6916	0,6478	6,3
3,071	0,8636	0,8839	2,4

Table 6: CFX Bulbed-Keel Resistance

Model theoretic resistance was compared for the keel and for the bulb separately obtaining better results for the bulb than for the keel.

The same test were carried out for the rudder, but the rudder angle was moved from $\delta = -12^\circ$ to $\delta = 12^\circ$. The results for 2,193 m/s and 1,316 m/s are shown below

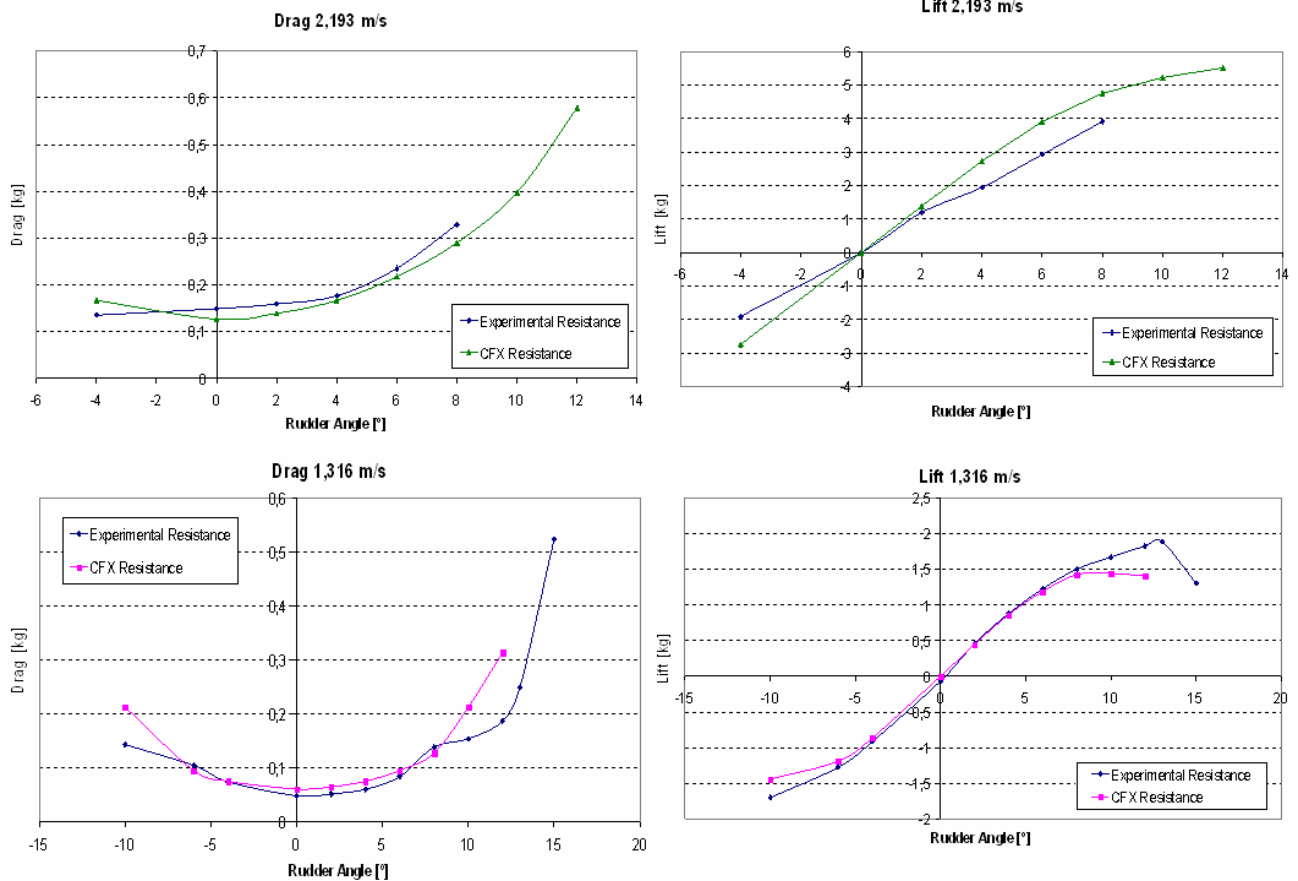

Figure 12: Rudder Lift and Drag

6 Conclusions

The present work contains the preliminary results of a series of tests performed in the towing tank of the ETSIN based on the separated measurement of hydrodynamic forces in canoe and appendages of a sailing yacht. The object of the project is to analyze the forces in the rudder in the presence of the keel.

The test technique allows obtaining characteristics hydrodynamics of keel and rudder normally not measured in conventional tests and that will allow to improve the knowledge of the phenomena of interference between appendices

The resistance of the rudder as measured directly on the rudder when fixed underneath the hull is smaller in the combination hull + bulbed - keel + rudder than in the combination hull + rudder.

Phenomena, like velocity reduction and downwash angle, in the flow of the rudder associated to the presence of the keel have been evaluated.

Results are used to fit to the viscous code CFX to this type of calculations, the numerical tests have obtained reasonable results but further work in this topic will be necessary.

7 Acknowledgements

The research has been funded by the Spanish Administration included in the project TRA 2005- – 08866 – C02-01.

8 References

- [1] J.A. Keuning, M.Katgert and K.J. Vermeulen "Keel-Rudder Interaction on a Sailing Yacht", 19th International HISWA Symposium on Yacht Design and Yacht Construction, Amsterdam, The Netherlands, November 2006.
- [2] J.A. Keuning, M.Katgert and K.J. Vermeulen "Further Analysis of the Forces on Keel and Rudder of a Sailing Yacht", the 18th Chesapeake Sailing Yacht Symposium, Annapolis, Maryland, USA, March 2007.
- [3] J.A. Keuning, K.J. Vermeulen "The yaw balance of sailing yachts upright and heeled", the 16th Chesapeake Sailing Yacht Symposium, Annapolis, Maryland, USA, 2003.
- [4] J.A. Keuning, K.J. Vermeulen and E.J. de Ridder "A generic mathematical model of the manoeuvring and tacking of a Sailing Yacht", the 17th Chesapeake Sailing Yacht Symposium, Annapolis, Maryland, USA, 2005.
- [5] J. Gerritsma "Course keeping qualities and motions in waves of a sailing yacht" Technical Report, Delft University of Technology, May 1971
- [6] J.A. Keuning, R Onnink, A. Versluis, A.A.m. van Gulik, "The Bare Hull Resistance of the Delft Systematic Yacht Hull Series" 14th International HISWA Symposium on Yacht Design and Yacht Construction, Amsterdam , The Netherlands, 1996
- [7] J.A. Keuning, U.B. Sonnenberg "Approximation of the Calm Water Resistance on a Sailing Yacht Based on the Delft Systematic Yacht Hull Series", the 13th Chesapeake Sailing Yacht Symposium, Annapolis, Maryland, USA, 1997.
- [8] J.A. Keuning, G.K. Kapsenberg "Wing - Body Interaction on a Sailing Yacht", the 18th Chesapeake Sailing Yacht Symposium, Annapolis, Maryland, USA, 2005.
- [9] J.A. Keuning, B.J.Binkhorst "Appendage Resistance of a Sailing Yacht Hull", the 13th Chesapeake Sailing Yacht Symposium, Annapolis, Maryland, USA, 1997.
- [10] J.R. Binns, K. Klaka, A. Dovell "Hull-Appendage Interaction of a Sailing Yacht, Investigated with Wave Cut Techniques", the 13th Chesapeake Sailing Yacht Symposium, Annapolis, Maryland, USA, 1997.
- [11] S.F. Hoerner "Fluid Dinamic Drag", Hoerner Fluid Dynamics, Bricktown, N.J., 1965-1992.
- [12] J.Meseguer Ruiz, A.Sanz Andrés , "Aerodinámica Básica". ETSI Aeronáuticos, Universidad Politécnica de Madrid 2005.
- [13] P. van Oossanen , "Predicting the Speed of Siling Yacht". SNAME transactions, Vol 101, 1993, pp 333-397

- [14] Martín Priego Wood, Leo M. González, Jorge Izquierdo, Adrián Sarasquete and Luis Pérez-Rojas "RANSE with free surface computations around fixed DTMB 5415 model and other Baliño's fishing vessels" 9th International Conference on Numerical Ship Hydrodynamics Michigan, USA, 5-8 August 2007.
- [15] Menter, F.R. "Two-equation eddy-viscosity turbulence models for engineering applications" AIAA-Journal, 32(8), 1994.
- [16] Wilcox D.C. "Multiscale model for turbulent flows". AIAA 24th Aerospace Sciences Meeting, 1986.