

IAC-08-E1.1.12

EDUCATIONAL GROUND STATION BASED ON SOFTWARE DEFINED RADIO

Author

Ramón Martínez Rodríguez-Osorio

Universidad Politécnica de Madrid. ETSI Telecomunicación. Ciudad Universitaria s/n. 28040 Madrid. SPAIN

ramon@gr.ssr.upm.es

Co-authors

Sergio R. Díaz-Miguel Coca

Universidad Politécnica de Madrid. ETSI Telecomunicación. Ciudad Universitaria s/n. 28040 Madrid. SPAIN

sdcoca@ieee.org

Frank R. Vedal

Narvik University College. ETSI Telecomunicación. Ciudad Universitaria s/n. 28040 Madrid. NORWAY

frv@hin.no

ABSTRACT

Most of student satellite missions are based on the design, construction and launch of a picosatellite (*cubesat*) including the design of the ground station (GS). Traditional GS are based on commercial elements and are designed to support only one mission. These stations access the mission data very inefficiently, as only contact the satellite during short visibility periods. In this paper, we present a novel GS concept based on software defined radio technology that can be integrated in a global network for satellite tracking. The station will be implemented by a group of students as a part of a space project under the supervision of a faculty coordinator. The design must fulfil the requirements of low cost, remote operation, and flexibility to operate in different frequency bands. The set-up of this mid-term educational space project to build an operational GS will hopefully motivate Telecommunication Engineering students to participate and gain real hands-on experience in an international space environment.

1. INTRODUCTION

Nowadays, there are a large number of Universities worldwide offering education in space technology related matters from satellite communications and applications to the design of the satellite platform. In most of the cases, the teaching methodology is based on the design of a space mission on a picosatellite platform. In particular, the space project consists in the design of a cubesat mission following the methodology used in a real mission. The concept of a cubesat and some examples can be found in [1].

Teaching methodology consists in dividing the students in different groups. Each team is responsible of one of the subsystems of the mission (propulsion, power, structure, communications, TT&C, etc.).

One essential part of the space mission is the design of the ground station. This subsystem is responsible of the tracking and communication with the satellite in

order to retrieve data from the payload, send commands and receive telemetry from the TT&C subsystem.

For a Telecommunication Engineering School the design of a ground station is the first step to face a space mission based on a cubesat. Firstly, the curricula of the students are related to the communication theory, signal processing and electronics areas. Secondly, most of the necessary equipment is available (oscilloscopes, spectrum analyzers, welding lab, simulation platforms, etc.). In order to avoid the expenses required for installing chambers of vibration and thermal tests of the satellite system. On the other hand, agreements between institutions are possible to share experiences and contribute with different areas of expertise. As an example, collaboration agreement between Technical University of Madrid and Narvik University College has started, and this paper is an outcome of this cooperation.

In this paper, we will focus in the design of a ground station in an educational context and how the associated tasks can be introduced in the leaning activities of a engineering career. As it will be shown in the paper, the implementation is based on the Project-Based Learning concept.

The concept of ground segment and earth station is evolving [2]. Traditional designs lack of flexibility and are tightened by the specifications of the commercial equipment which drive the design of the communication subsystem. In particular, commercial radios operate with 9600/1200 bps frames modulated in FSK/AFSK according to the specifications of AX.25 protocol [3].

Educational satellites are located in a quasi-polar low-earth orbit (LEO). This fact makes the visibility time from ground is very short. According to GENSO, the period of contact is 5 minutes in average, and communication with the satellite can only be established during the 3 % of the life time [4].

In order to increase the amount of data downloaded from the satellite, one possible solution is an increase of the data rate. In this case, the cost of the payload would be increased due to the higher complexity and storage mass on board. On the other hand, educational ground stations are designed to track only one mission (normally, the satellite built by each University of Laboratory), so that no communication can be established with other similar satellites.

Some international initiatives to increase the efficiency of satellite missions rely on the formation of a global ground station network to track educational satellites. These initiatives have started with the support of European Space Agency (ESA) and the Space and Systems Development Laboratory (SSDL) in Stanford University. The idea is the deployment of a global network with stations interconnected through Internet and able to communicate with every satellite of the network. In this way, the access to the data is improved, information from the satellite is available in quasi-real time, and the use of both satellite and earth station is optimized as the number of contacts increases with the number of ground stations.

As first initiative, the GENSO (Global Educational Network for Satellite Operations) Project starts with the support of ESA and ISEB (International Space Education Board) [4]. The main objective is to define a global standard based on software to interconnect educational and amateur radio ground stations (both operate in the same frequency bands), and able to communicate with any satellite of the network, and send the data to any operator through the Internet. The idea is based on the sharing of distributed resources to offer global coverage and access to satellite data.

Fig. 1 shows schematically the concept of global tracking network. The requirements of the ground station integrated in this network are:

- Multimission and multichannel
- Remote operation with secure access
- Low cost
- Possibility of being used with in teaching activities

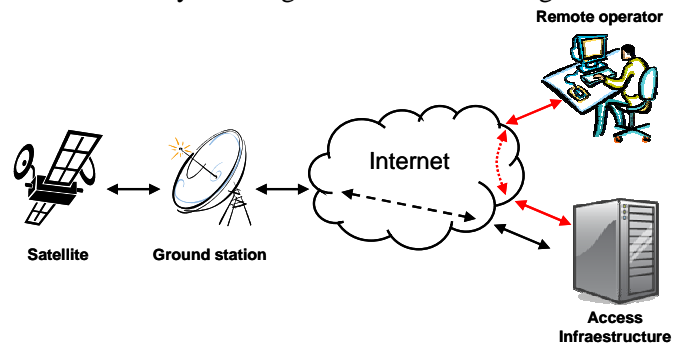

Fig. 1. Concept of Ground Station Integrated in the Global Network.

Another approach to the concept of global ground station network is denoted as *virtual ground station* [5] and is supported by SSDL. It integrates the advantages of software radio technology and the execution of routines in virtual machines to form Software Defined Ground Stations (SDGS) [6].

The combination of both technologies can permit. In this architecture, tasks related to processing radio signals are encapsulated in virtual machines that are executed in different processors (FPGA, DSP, ASIC, GPP). Processes like demodulation, synchronization, channel coding, etc. are executed in distributed virtual machines interconnected with broadband links. Thus, flexibility and reliability are improved at the cost of performing software processing which is slower than in dedicated hardware [7].

In this contribution, the design of a ground station based on software radio for the amateur radio bands in an educational context is presented. Section 2 describes the traditional ground station model is compared to ground station concepts based on software radio technology. Section 3 presents a preliminary software radio design proposed by Technical University of Madrid in cooperation with Narvik University College. An estimation of the cost to develop the ground station is presented in section 4. Next section describes how to introduce the ground station design as a part of the engineering studies, and finally, section 6 draws the main conclusions of the paper.

One of the main objectives of the proposed ground station is its integration in the GENSO network in the mid-term as a contribution from Technical University of Madrid.

2. GROUND STATION ARCHITECTURES

A. Traditional design

Traditional ground station designs associated to student satellite missions are formed by commercial elements. Although the operation of such a station is simple, the cost is rather high and the design lacks of

transparency. The station operates in a single frequency, so that processing several radio signals simultaneously is not possible.

A typical ground station is formed by four main components:

- **Antenna:** depending on the frequency band, different antennas can be used. For amateur radio bands, helix and yagis are normally used for VHF and UHF, whereas reflectors or patches can be used for S band. Antenna arrays can be deployed in case the gain of the individual element is not enough to satisfy the link budget.
- **Positioner:** it controls the antenna orientation to track the satellite. Usually, the tracking is made mechanically by means of rotors. View angles are delivered to the positioner via the control port (e.g. RS-232) by a satellite tracking software.
- **Transceiver:** it translates the modulated signal to a carrier frequency in the ground-satellite link band.
- **Modem:** it modulates or demodulates the information frames transmitted by the ground station or received from the satellite, respectively.

As it is shown in Fig. 2, the ground station is divided in two main parts: antennas, installed in the rooftop, and the electronic equipment, located in a room near the antenna. Each commercial component is a black box for the ground station operator. In this example, two antennas are used for each band in order to combine the received signals and provide an extra gain of 3 dB.

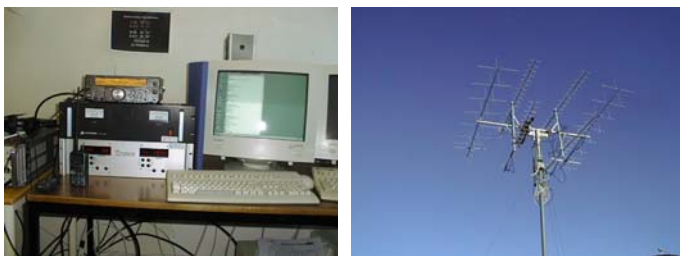

Fig. 2. Ground Station in Narvik University College [8].

Regarding the software, the ground station requires an application to control the positioner and point the antenna at the direction of the satellite. There are a number of alternatives, being the most used the commercial software *NOVA*[®] and the open source tool *Predict*.

It is also possible that this software calculates the Doppler deviation due to the movement of the satellite in the LEO orbit. This information can be used to tune the exact carrier frequency of the ground station receiver and thus simplify the synchronization stages for the demodulator.

B. Design based on SDR

Fig. 3 shows the architecture of a ground station based on software defined radio (SDR) that satisfies the requirements of multimission and multichannel (VHF, UHF and S bands). As a possible application,

communication could be established with a satellite transmitting in VHF and S band, and receiving commands in UHF (for instance, AO-51 satellite).

Some requirements must be satisfied by the equipment. First, the antenna must receive signals in every band, so that a broadband or multiband designed is required. As an option, a different antenna for each band can be installed. Second, the analog front-ends (amplification, filtering, up and downconversion) are independent for each band.

In the receiving path, after combination/switching, the signal is filtered, translated to a common intermediate frequency (IF) and digitized using a data acquisition board (in transmission, the inverse process is performed). The most adequate design for this stage is bandpass sampling, as it will be explained in section 3.

After sampling, the digital signal processing takes care of demodulation, including decimation, synchronization and decoding to extract the bits.

The General Purpose subsystem performs several tasks: calculation of view angles (azimuth, elevation) to orient the antenna, positioning control, configuration of the switches and synthesizers. In case of tuning lines, the Doppler deviation can be estimated by spectrum analysis of the incoming signal, therefore making the receiver independent of the tracking module [9]. Although not explicitly depicted in the figure, both data acquisition and control subsystems are controlled by a PC.

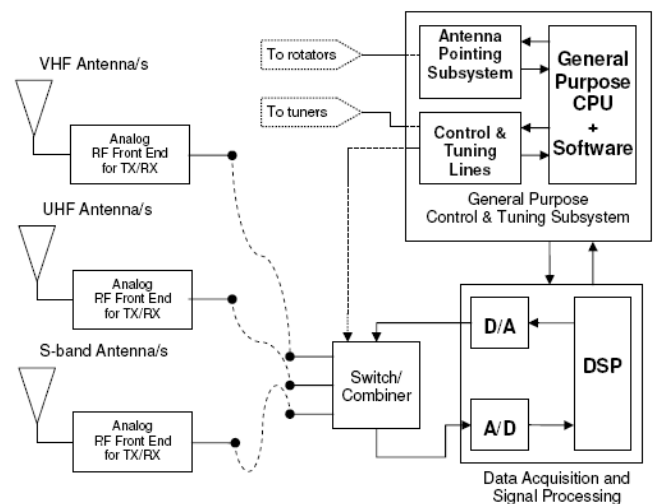

Fig. 3. Ground Station Based on Software Defined Radio.

Some of the innovations that can be introduced in a ground station based of software radio technology are:

- **New tracking technologies:** apart from the automatic control of the antenna, monopulse tracking could be implemented in the hardware platform;
- **Array processing and electronic tracking:** using an antenna array and a multichannel receiver, beamforming schemes could be introduced to improve the quality of the receive signal, cancel

interferences and increase the visibility time [10]. As part of the tracking system, the mechanical tracking can be complemented with electronic beamsteering, making the tracking more accurate;

- Introduction of new communication technologies: in particular, LionSat (Local Ionospheric Measurements Satellite) developed by Penn University and sponsored by NASA aims at designing a ground station based on SDR to evaluate IP protocol through a nanosatellite [11].

Several commercial platforms are available for implementing the software defined radio concept. As an example, Fig. 4 shows the XtremeDSP which has been selected by UPM for the implementation. It provides analog interfaces (two A/D and two D/A converters), so that multiple analog inputs/outputs can be processed simultaneously. This is very convenient in case several RF stages must be installed. Moreover, it can be used for transmitting signals to the satellite. Thanks to the broadband sampling features (over 100 MHz), band pass sampling can be performed. For the signal processing, the board is equipped with a Virtex-IV FPGA [12].



Fig. 4. XtremeDSP Platform (©Xilinx).

C. Design based on PC receiver

In the previous design, the digital signal processing is performed in an external hardware platform responsible of the digitization and bit extraction. In a design based on a PC receiver, the external platform so that samples are transferred to the PC. Here, a software program (e.g. developed in Matlab[®]), takes care of the demodulation.

The advantages of this approach are the flexibility of the design which is also easily upgradeable, the off-line processing and lower cost (the software radio platform is not required). As main disadvantage, signal processing in software routines is performed slower than in hardware, implying that the feasibility of the software receiver depends on the sampling and symbol rates.

As an example of this architecture, the A3TB (Adaptive Antenna Array Test Bed) system this

approach to improve the flexibility of the demonstrator [13]. In A3TB, array processing and receiver functions are performed over the digitized samples delivered by the analog-to-digital converters.

3. PRELIMINARY GROUND STATION DESIGN BASED ON SDR

The main objective of our ground station design is to provide a wide and robust multi-mission support in a resource-efficient manner and in as many amateur-satellite frequency bands as possible.

In this way, the ideal ground station design would be defined as a “universal transceiver” capable to work in every frequency band, with any bandwidth, any polarization, full-duplex, and using any of the modulation and coding techniques that could be required in the present or that could arise in future applications.

However, this short description of a universal transceiver is far from being realistic for an efficient and low cost implementation with the current state of the art. Thus, our ground station design will limit its working frequencies to the VHF, UHF, and S amateur bands.

In order to keep the costs under reasonable limits, an SDR based design is the one that we have found flexible the most concerning aspects such as modulations, coding, bandwidth, reusability and remote use.

Our SDR design is based on the implementation of an undersampling scheme in order to down-convert and digitize the VHF, UHF and S-band signals by means of bandpass sampling techniques.

The Nyquist-Shannon theorem for baseband sampling, states that we must use a sampling frequency at least twice higher than the highest frequency of our analog signal to avoid spectrum aliasing.

The aliasing occurs due to the fact that, when it is sampled, the spectrum of our signal is frequency modulated to every integer of the sampling frequency. In this way, considering the negative part of the spectrum, we need the first aliases of our signal to fall at least twice the highest frequency apart from DC.

On the other hand, the bandpass sampling techniques make an interesting use of this aliasing/modulation effect as a way to simultaneously digitize and down-convert the incoming RF signal [14].

In other words, we could say that “bandpass sampling is the intentional aliasing of the information bandwidth of the signal” [15].

Thus, the bandpass sampling theorem states that a bandpass limited signal going from F_d to F_u will avoid spectrum aliasing, and then, it could be reconstructed, when sampling with a minimum sampling frequency which is determined by eq. (1):

$$F_s^{(\min)} = \frac{2}{n} F_u \quad \text{where } n = I_g \left[\frac{F_u}{BW} \right] \quad (1)$$

Here, $I_g[x]$ represents the largest integer number within x . It is important to remark that $F_s^{(\min)}$ represents a minimum valid sampling frequency, although it does not mean that any higher sampling frequency will be valid. Actually, only some of them will be valid depending on the final location of our intermediate frequency after sampling is performed.

The post-sampling intermediate location of the RF signal is determined by eq. (2).

$$\text{if } \text{fix} \left(\frac{F_u}{F_s/2} \right) \text{ is } \begin{cases} \text{even,} & F_i = \text{rem}(F_u, F_s) \\ \text{odd,} & F_i = F_s - \text{rem}(F_u, F_s) \end{cases} \quad (2)$$

Here, $\text{fix}(a)$ is the integer portion of argument a , and $\text{rem}(a,b)$ is the remainder after division of a by b .

Fig. 5 shows a block diagram of a software defined radio receiver architecture for the direct sampling of a given RF bandpass signal.

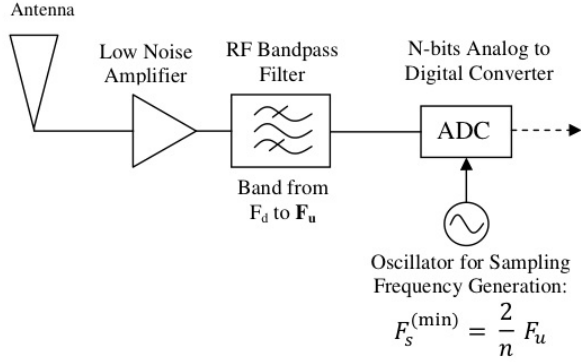

Fig. 5. Direct Bandpass Sampling of an RF Signal.

The main advantage of this architecture is that the analog RF front-end is notably reduced since no analog mixing is performed.

In the same way, we can design a software defined radio architecture to simultaneously receive multiple bandpass limited signals by considering a block diagram as simple as the one shown in Fig. 6.

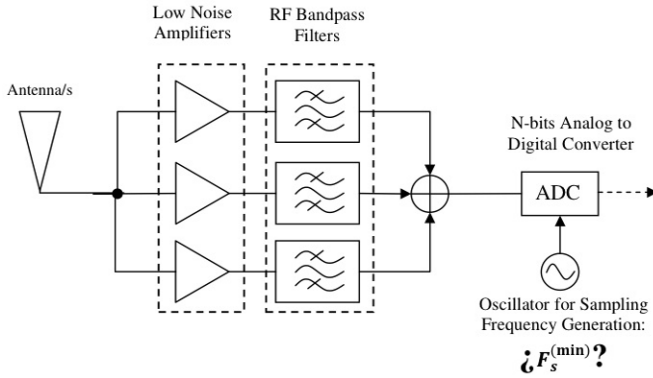

Fig. 6. Direct Sampling of Three Non-Adjacent RF Signals.

In this situation, the big question is the sampling frequency to be used. The spectral evolution when sampling in such a situation in order to avoid aliasing is

depicted in Fig. 7. This is what it is called an undersampling scheme.

Thus, when implementing such architecture we will have strong restrictions for selecting a proper sampling rate.

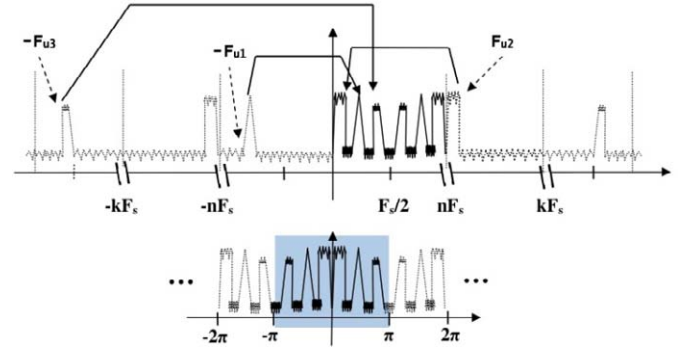

Fig. 7. Undersampling Scheme. Spectrum Evolution. Three Non-Adjacent RF Signals.

These restrictions are specified in equations (3) and (4). The two constrains of equation (3) basically mean that our signals bandwidth must keep entirely within the same Nyquist zone in order to avoid self-aliasing:

$$\begin{aligned} 0 &< F_{IF} - \frac{BW}{2} \\ F_{IF} + \frac{BW}{2} &< \frac{F_s}{2} \end{aligned} \quad (3)$$

Here, F_{IF} is the centre frequency of the band falling in the first Nyquist zone that can be calculated by using by using equation (2).

The constraint in equation (4) is added so that the different bands do not cause mutual co-band overlapping. Equation (4) is defined for an undetermined amount N of non-adjacent RF bands.

$$\begin{aligned} |F_{IFb} - F_{IFa}| &\geq \frac{BW_b + BW_a}{2} \\ \text{for } a &= 2, \dots, N \quad \text{and } b = 1, \dots, a \end{aligned} \quad (4)$$

In other words, this equation means that none of the intermediate bands location should produce any interference with any of its neighbour bands once they are sampled.

As we have just mentioned, selecting a valid sampling rate when using undersampling schemes to sample multiple bandpass RF signals is not an arbitrary task. Actually, making a proper selection of the sampling rate will be the key point for our system to be theoretically and, most important, practically feasible.

In summary, we can say that the problem of finding a valid sampling rate is reduced to the application of equations (3) and (4). However, these formulas will not lead us to any specific valid sampling frequency values since they are actually inequations.

In this manner, in order to find the best sampling rates, it has been a really big issue to find a method to easily study and make proper calculations when

designing an SDR architecture to work in the VHF, UHF and S bands of the amateur-satellite service.

No other way to find a valid sampling frequency was used rather than an iterative process of spectrum sweeping in order to find a proper one. At the beginning, it was barely feasible to find a valid sampling rate. It was mostly a matter of being lucky with your calculations.

But, as long as we need to apply new requirements such as new RF input bands or new hardware restrictions (i.e., state of art of the current ADCs, variable RF filter bandwidths, feasible sampling rates, digital down converter decimation rates, ADC's analog bandwidths, SNR, jittering, etc.); it really arose the need for computer assistance for this process not to lead to non-optimized designs.

This is why we developed an application to assist us on the selection of a valid sampling rate for a software defined radio when sampling an undetermined number of non-adjacent RF bands [16]. A screen shot of this application is shown in Fig. 8.

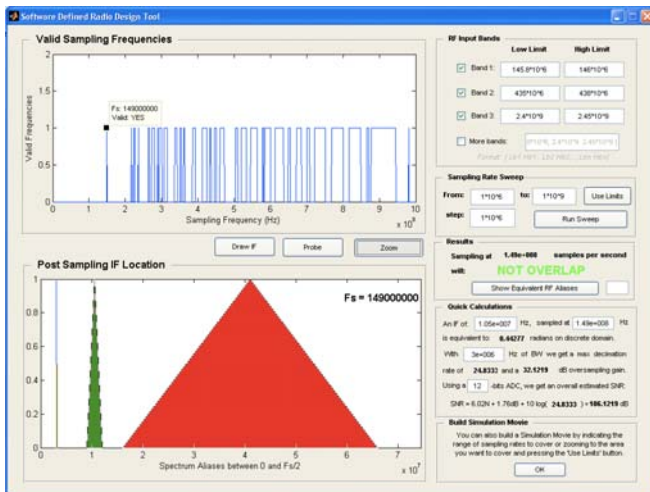

Fig. 8. Software Defined Radio Tool. Graphical User Interface.

This application will be also helpful to understand the spectrum influence of minor changes of the sampling rate, as well as to solve other problems such as finding equivalent analog intermediate frequencies within our ADC's analog bandwidth and some other useful calculations.

Using this application, we could perform an initial approach to our ground station design that looks as depicted in Fig. 9.

In this receiver diagram a Digital Down-Converter (DDC) is added for relaxing the required processing speed as well as increasing the system SNR with the oversampling gain that is inherent to the decimation process.

We will also have to take into account other problems concerning clocking high speed ADC's and clock jittering to avoid extra SNR degradation.

It can be appreciated that a new PLL Synthesizer has been added in order to cover the whole 50 MHz

range that is reserved for the S-band of the amateur-satellite service and, at the same time, reduce the minimum required sampling rate down to 68.04 MHz.

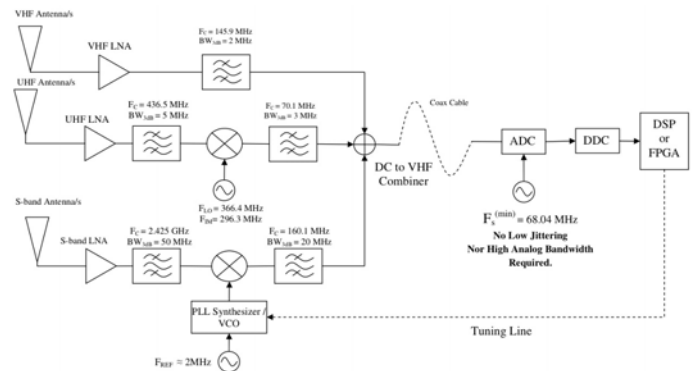

Fig. 9. Final Band-Bass Design.

In this way, the down converted bandwidth of the S-band part will be narrowed to 20 MHz which is more than enough bandwidth for most applications. Actually, this bandwidth was chosen due to the fact that 20 MHz is the maximum allowable channel bandwidth to be used in the amateur S-band allocation.

The main advantages and disadvantages we found on this design in relation to some other SDR designs and typical super-heterodyne architectures are summarized below.

Advantages:

- Flexible and robust multi-mission support. Any modulation and coding would be theoretically supported as far as we have enough processing speed (in DSP or FPGA).
- Otherwise, we can even make later post-processing of stored signals if no real-time is required.
- The minimum required sampling frequency is dramatically reduced.
- Standard 70/160 MHz IF values for both analog down-conversions.
- The required A/D converter analog bandwidth has been reduced to VHF. Most converters in current SDR platforms support these analog inputs.
- All of the signals are combined into one cable.
- The jitter effect influence is greatly reduced since the maximum analog input is decreased from S-band to VHF.
- The cable will be cheaper and with lower attenuation since all of the carriers are constrained below VHF.
- The combiner bandwidth is reduced to VHF.
- No remote switches are needed for antenna selection.
- The whole S-band amateur bandwidth (50MHz) is covered while keeping low sampling rates.
- Simultaneous tri-band capable if enough processing power is available.
- If we had enough analog bandwidth in the ADC we could also avoid UHF down-conversion.

Disadvantages:

- A remote tuning line is required for the PLL Synthesizer. This will require an extra hardware and software effort. It could be avoided by covering just the preferred 20 MHz of the S-band and using a fixed oscillator. Another option could be to increase the IF filter bandwidth up to 50 MHz and then requiring higher sampling rates.
- Very specific sampling rates are required.
- High A/D resolution would be recommended.
- It is really complex to study and to take decisions in a situation where we have two undetermined analog input frequencies. This issue has been partially overcome by the final development of the SDR Tool.

4. COST

The cost of deploying the proposed software defined radio ground station will vary a lot mainly depending on the acquired SDR platform. Also, the budget is really influenced by the amount of cable to be deployed among the antenna system and the SDR, so that the site selection must be carefully done.

Fig. 10 shows a preliminary budget required for the material of the ground station. It should be interpreted qualitatively as final prices will depend on the provider and economies of scale.

Resource	Estimated Price
SDR Platform	400 - 10,000\$
Analog RF Front Ends	100 - 1,000 \$
Cabling	500 - 5,000 \$
Antenna and Pointing System	400 - 3,000 \$
Mission Control Computer	0 - 2,000 \$
	1,400 - 21,000 \$

Fig. 10. Final Band-Bass Design.

As, we can see the SDR and cabling are the resources that will influence the most. Besides, the MCC can be almost costless in the case that we reuse some available PC combined with open-source software. In fact, the GENSO system will work on Linux systems as well as on Windows.

Finally, it should be emphasized that investments in high quality components, will lead to better system performance which is the overall goal of a network of ground stations.

5. PROJECT-BASED LEARNING IMPLEMENTATION OF THE GROUND STATION

The aim of the design approach presented in this paper is to promote the active participation of telecommunication engineering students in the ground station design. The implementation in students' curricula will be based on Project-Based Learning (PBL). Under this methodology, students learn concepts by doing. In particular, PBL begins with a

final product or "artifact" in mind (i.e., the ground station), the production of which requires specific content knowledge or skills and typically raises one or more problems (i.e., design of antenna, selection of hardware, site location, etc.) which students must solve [17]. PBL methodology is close to the ideas of European Space for Higher Education, an initiative to create a common framework for higher education in Europe with the goals of enhancing the employability and mobility of citizens and to increase the international competitiveness of European higher education [18].

In a traditional design, the ground station is formed by commercial components. It means that the main participation of students is in the form of ground station operation and not in the design. The design approach is based on the selection of appropriate equipment.

In contrast, following a design based on software defined radio technology, students have the opportunity to design themselves core parts of the receiver. In the mid-term, once the station is working, students have the opportunity to operate the satellite tracking process and introduce improvements in the design to optimize the performance or update the station to track new missions.

For the implementation in terms of project-based learning several phases must be planned from the beginning:

- 1) Selection of one or more satellites to track with the ground station under design
- 2) Design of the station in paper (models): first decisions on antenna model, receiver, etc.
- 3) Verify the design using simulation. In this phase, both electromagnetic and signal processing analyses are required.
- 4) Selection of components and budget
- 5) Site selection to install the antenna and equipment.
- 6) Integration of components and set-up
- 7) Test plan in laboratory and field measurements
- 8) Remote access schedule and permissions
- 9) Guide for operating the ground station

The overall project phasing and process in each stage must be done according to the standards followed in space projects (e.g., ECSS). In this context, seminars and supervision provided by industry experts will enrich the project result.

One important issue about the design of a ground station is that it implies a multidisciplinary approach. In an educational framework, students with different and complementary profiles must take part in the project:

- Communications: link budget analysis, selection of modulation, RF stages, antennas, etc.
- Electronics: software radio platform, hardware, etc.
- Computer Science: software, remote access, user authentication, security, data base management, etc.
- Management: public relations, budget, marketing, definition of services and applications, etc.

- Space Orbits: satellite orbit path, mechanical and moving features of the antenna, etc.

Students should be divided in working groups each with clear tasks to avoid overlapping. Coordination of students and groups is done by an academic supervisor, that can be complemented by external space experts. Interaction between groups is made in periodic meetings. The total time to implement the ground station will depend on the number of participant students. Typically, more than one course is required; therefore it is very important that the knowledge transfer is made between successive groups with total efficiency. In this sense, it is very important to generate documentation and reports with high quality.

Finally, thanks to the software nature of the design, students have the opportunity to share with other groups their routines and experiences. A software repository could be made available to all interested groups in order to promote the formation of a student network. Also, sharing of downloaded data from the students missions could be possible.

Apart from the technical-specific capabilities, the PBL methodology reinforces generic skills such as teamworking, decision-making, report writing and oral presentations, and resource management.

6. CONCLUSIONS

In this paper, the design of a ground station based on software radio is presented as a means to introduce practical aspects of a space project in the Telecommunication Engineering degree. The principles that drive the design are flexibility, remote access, low cost and capacity to process several frequency bands simultaneously.

Compared to traditional designs where most of the components are commercial, in a software defined approach students have the opportunity to participate in the design of the modules (antenna, modem, etc.) and familiarize with the operation of the station.

Moreover, as the cost of the station might be low, universities and other educational institutions willing to have an own ground station has the opportunity to have one located in their premises.

The methodology to introduce the ground station design in student activities is Project-Based Learning, where participants get in touch with practical aspects and acquire hands-on experience in a space project. Likewise, once the station has been designed, it can be used in a long-term approach with updates, new versions of the software, operation, thanks to its software-based nature.

Finally, it is important to mention that the ground station is prepared to be integrated in a global network for tracking of student satellite missions. Therefore,

students will be motivated to participate in a project developed in an international framework.

ACKNOWLEDGMENTS

Authors wish to thank faculty and students participating in HiNCube from Narvik University College for their support and sharing of experiences in developing ground stations for student missions.

REFERENCES

- [1] The CubeSat Project [online]. Available: <http://www.cubesat.org>.
- [2] James Cutler, "Software Defined Ground Stations", 5th CubeSat Developers' Workshop, Cal Poly, April 9th-11th, 2008.
- [3] AX.25 Amateur Packet-Radio Link-Layer Protocol, ver. 2, Rev. 1998 [online]. Available: http://www.tapr.org/pub_ax25.html.
- [4] GENSO Project Information, <http://www.genso.org>.
- [5] James Cutler, "Lessons Learned from Remote Ground Station Operations", 4th CubeSat Developers' Workshop, Huntington Beach, CA, 19th-21st April, 2007.
- [6] Software Defined Ground Stations (SDGS), Space and Systems Development Laboratory, Stanford University [online]. Available: <http://ssdl.stanford.edu/ssdl/index.php>.
- [7] James Cutler, Armando Fox, "A Framework for Robust and Flexible Ground Station Networks", Journal of Aerospace Computing, Information and Communication, vol. 3, pp. 73-92, March 2006.
- [8] The HiNCube Project, Narvik University College [online]. Available: <http://hincube.hin.no/>.
- [9] Jyh-Ching Juang, Chiu-Teng Tsai, "Software Defined Radio Approach for the Implementation of Ground Station Receivers", 5th CubeSat Developers' Workshop, Cal Poly, April 9th-11th, 2008.
- [10] R. Martínez Rodríguez-Osorio, Alberto Bravo Sánchez, Miguel A. Salas Natera, "Design of a Software Radio Prototype for the Analysis of Beamformers in Satellite Communications", Proc. 2007 IEEE 66th Vehicular Technology Conference (VTC-2007 Fall), pp. 2060-2064, Baltimore, MD, Sept. 30th - Oct. 3rd, 2007.
- [11] Nathan F. O'Connor, Brendan S. Surrusco, Sven G. Bilén, and Charles L. Croskey, "Software-Defined Radio Ground Station for Internet-Protocol Communications to a Low Earth Orbit Nanosatellite", Fourth Space Internet Workshop (SIW-4), Hanover, MD, 8th-10th June, 2004.
- [12] *XtremeDSP Development Kit-IV User Guide*, 09/03/05, Nallatech.
- [13] R. Martínez, M. A. Salas, A. Antón, I. García-Rojo, "A3TB: Adaptive Antenna Array Test-Bed for Tracking LEO Satellites based on Software-Defined Radio," to be presented in 58th IAC (International Astronautical Congress), Glasgow, UK, 28th Sept.-2nd October, 2008.
- [14] Rodney Vaughn, N. L. Scott, D. R. White, "The Theory of Bandpass Sampling", IEEE Trans. Signal Processing, vol. 39, no. 9, pp. 1973-1984, Sept. 1991.
- [15] Dennis M. Akos, Michael Stockmaster, James B. Y. Tsui, Joe Caschera, "Direct Bandpass Sampling of Multiple Distinct RF Signals", IEEE Trans. On Communications, vol. 47, no. 7, pp. 983-988, July 1999.
- [16] Sergio R. Díaz-Miguel Coca, *Proposal of a European Station Network and its Application in Teaching Satellite Communication*, Master Thesis, ETSI de Telecomunicación, UPM, Dec. 2008.
- [17] The PBLE Guide. Educating Engineers using Projects [online]. Available: <http://www.pble.ac.uk/guide-final.html>.
- [18] The Bologna Declaration on the European space for higher education: an explanation, http://ec.europa.eu/education/index_en.htm.