

# Modeling and simulation requirements for the analysis and design of DC distributed power electronic systems

J. A. Oliver, R. Prieto, L. Laguna and J. A. Cobos

Universidad Politécnica de Madrid  
Centro de Electrónica Industrial (CEI)  
c/ José Gutiérrez Abascal, 2  
28006 Madrid. SPAIN.

Phone: + 34 91 4117517 Fax: + 34 91 5645966

e-mail: [jesusangel.oliver@upm.es](mailto:jesusangel.oliver@upm.es)

## Abstract

The objective of this paper is to establish which are the requirements of the component models in a distributed power system in order to satisfy the necessities of the system architect. Based on the information that will help the designer to make the right decision for its architecture and the selection of their components, different levels of modeling will be required for each simulation.

The paper also shows the implication of the modeling approach on the requirements for the simulator and the description language.

## 1. Introduction

Complexity and reduced time to market are the two main forces in the field of distributed power systems that are making the designers to rethink their current

design flowcharts. The complexity is given by the applications (mobile devices, large data centers, more electric vehicles) in which the number of loads and number of different power sources is continuously increasing and also their requirements. Figure 1 shows a simplified structure of a typical system used in power distribution for aerospace. It can be seen that these systems are mainly composed by AC/DC and DC/DC converters, filters, circuit breakers and non linear loads.

These factors are fostering the use of simulation in all the design process to reduce the uncertainties and increase the possibilities of first time success.

The simulation tools are oriented to extract valuable information about specific areas of the design (thermal, electrical, control, reliability). The use of these tools is particularly important in the area of power conversion and power management where the design methodologies supported by simulation are not mature.

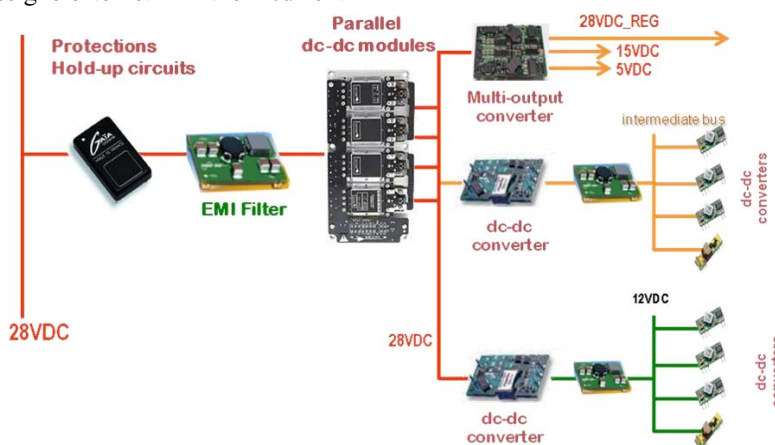

Figure 1 Simplified structure of a power distribution system for an aerospace application

Additionally, in order to reduce the time to market, the uncertainties in the design and the cost, the use of commercial components is gaining acceptance over custom made solutions. In these cases, the internal structure of the components and their parameters are not known, since they are part of the intellectual property of the manufacturer, and traditional modeling techniques such as averaging cannot be applied. So it is necessary to develop new modeling techniques that can capture the behavior of the components, preferably by means of the information provided by manufacturers in their datasheet or some additional measurements.

Thus it is necessary to develop an efficient and accurate enough design methodology that will help to arrive at feasible solutions in a least amount of time. In order to do that, it is essential to understand which are the requirements of the distributed power system architects and how those requirements affect the needed models.

This work summarizes the requirements that the system simulation should present. These requirements have been extracted from previous experience working in projects in the area of modeling and design of power electronics systems for different applications.

## 2 System level requirements for power converters

The design of power distributed systems requires the evaluation of different performance metrics of the systems that range from its efficiency up to the timing sequencing of the different converters and how it affects to the global stability. This section deals with the necessities of the system designers and how they affect the specific model characteristics.

### 2.1 Static requirements

The efficiency of the power electronic converters depends on its operating conditions (input voltage and load), and this influence can have a significant effect on the performance of the power distribution system. Typically, at light load, the efficiency of the converter decreases considerably. Meanwhile this effect has been traditionally ignored because the tendency was to increase the power density, that is driven by the thermal limitations at maximum load, today there are more and more applications in which the light load efficiency has a critical impact on the whole system efficiency (especially in data servers or portable devices) [1]. As a consequence, it is very important from the designer point of view to have accurate models that account for the influence of the input voltage and load on the efficiency of the converter.

These static models can cover the first stages of the design in which very useful information can be obtained:

- **Power budget** under all input voltage conditions and loads. This information is very useful for determining the capacity of the power sources or dimensioning backup storage elements.
- **Thermal management.** The power losses of all the components under different scenarios can be used as inputs to Finite Element Analysis tools in order to design the cooling system and optimize the component location.
- **Wiring and protection pre-dimensioning.** Based on the data provided by the simulation, the maximum steady-state currents under all working conditions can be estimated and used for the selection of the harnessing and protection pre-dimensioning.

### 2.2 Dynamic requirements

As it has been shown above, the static model of the converters provide good information for the power distribution system designer that can help in the analysis of different architectures and the selection of the right components for those architectures. Nevertheless, there are some critical issues in the architecture that have to be addressed before making the final decision. All these factors are related to the stability of the system:

#### 2.2.1 Small signal behavior

The models of all the components in a distributed power system have to account for their small signal behavior. It means that they have to reflect the basic interactions among components that can yield to system instability. In the particular case of power converters, they have to correctly account for the input impedance, and the influence of the load in the input impedance and the output impedance.

The small signal models are of great interest in order to check for the robustness of a design applying well known techniques such as the Middlebrook's criterion [2].

#### 2.2.2 Large signal behavior

The increasing complexity of the systems to be powered, not only due to the higher number of loads and sources but because of the higher requirements in terms of power management are driving the use of dedicated controllers and the development of communication buses, such as PMBUS, that are becoming an standard.

The added functionality of the power converters has to be taken into account, that is, the model has to include its event driven behavior that includes functions such as:

- **Remote powering.** System designers usually require the ability to power on and off some parts of the system in order to reduce the power consumption or to isolate them in case of faults. Thus it is necessary to take this functionality into account.
- **Programmable output voltage.** Energy efficient techniques such as DVS require a programmable output voltage that will be modified as a function of the work load requirements of the microprocessor.
- **Programmable protections.** Protections can play an important role on the stability of the system. Especially undervoltage protection that turn-off the converter when the input voltage drops below its minimum can yield to sustained oscillations due to the interactions of the converter and the input filter as will be shown in the validation section.
- **Soft-start.** The start-up of the power system can be greatly improved by the adequate sequencing and selection of the soft-start characteristics of the power processing elements. To validate and design the power management system the models have to include the soft-start behavior of the power converters.

### 2.3 Identification requirements

Present day trends toward the use of commercial components makes impossible to use well known modeling techniques such as averaging [3]. These commercial converters present significant advantages over custom made solutions since they can reduce significantly the development time, critical in fast changing markets, they usually have lower area and smaller form factors, reduce the component count and also the cost.

In these cases, the internal structure of the dc-dc converter and their parameters are not known, since they are part of the intellectual property of the manufacturer, and the averaging techniques cannot be applied. So it is necessary to develop new modeling techniques that can capture the behavior of the converters preferably by means of the information provided by manufacturers in their datasheet or some additional measurements [4]-[5].

### 3 Proposed converter model structure

In order to fulfill all those requirements the model structure shown in Figure 2 is proposed for modeling

dc-dc converters. This model considers dc-dc converters as a hybrid system [6]. All the protections and remote control features are managed by the logic system (event driven behavior) and the power stage and control is modeled by a Wiener-Hammerstein structure (see figure 1). The parameters of the proposed structure are based on the values given in the datasheets [4].

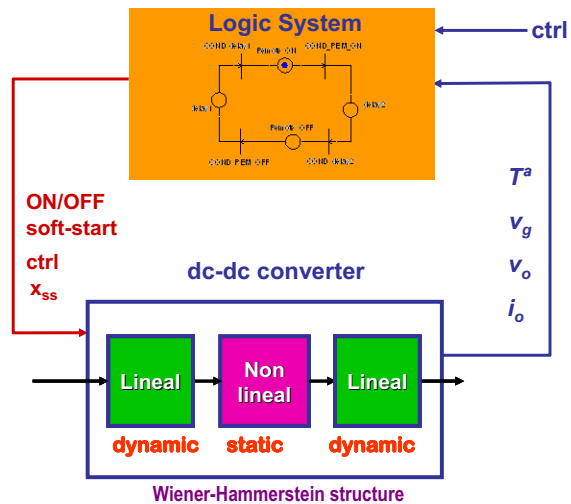

Figure 2 Proposed dc-dc converter model structure

For the continuous model of the converter a Wiener-Hammerstein structure has been selected, as shown in Figure 3, this structure consists of three blocks: a static nonlinear block and two linear blocks for the input and output dynamics respectively.

**The static non-linear block.** This element determines the steady-state behaviour of the converter, accounting for the variation of the output voltage with the input voltage and the load and also the influence of these variables on the efficiency of the converter.

**The linear dynamic input block.** This block accounts for the high frequency behaviour of the input impedance, since the low frequency behaviour is given by the static block. It can be identified from the inrush current data of the converter [4].

**The linear dynamic output block.** The dynamic response of the dc-dc converter to load changes is given by this network that is determined by the load step response provided by the manufacturer [4].

Additionally, a **simplified thermal model** for the converter is included to take into account thermal protections on the stability of the system

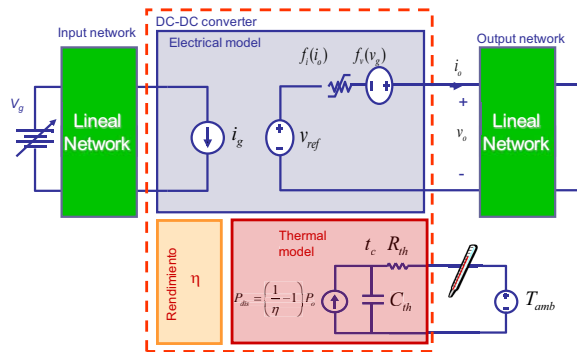

Figure 3 Wiener-Hammerstein structure proposed for the converter

### 3 Simulator requirements

The implementation of the models with all the functionality described in the previous section imposes some special features to the simulator to be employed. This section presents several recommendations and differences for the model implementation for system simulation compared with the models used for circuit simulation.

1. The models must present **different levels of abstraction** depending on the information that should be extracted from the simulation. This way, depending on the complexity and information characteristics that should be extracted from each simulation, the model can

present different implementations in order to perform faster simulations with lower convergence problems.

2. The selection of the **language** used to implement the model is also an important decision. The model language should present the following features:

- ✓ **Portability**. The model should **work in different simulation platforms**. This point is particularly important in systems where different fields should be simulated together (hydraulics, electronics, fluids, mechanical,...) and therefore different design tools are used to design each part of the system. This favors the use of standard languages such as VHDL-AMS or Verilog-AMS. The characteristics of the VHDL-AMS are graphically shown in figure 3.
- ✓ Behavioral modeling capabilities. That is, the language must allow the implementation of **expressions and equations** to describe the model, as well as parametrization capability.
- ✓ It should be a **high level language** in order to easily describe complex systems allowing the understanding of that description by other designers.

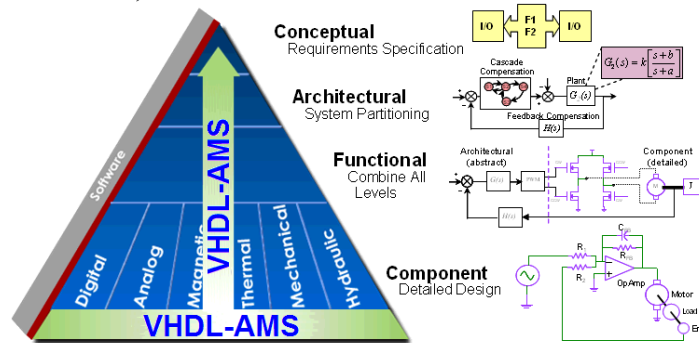

Figure 4 VHDL-AMS characteristics

## 4 Examples and validation

This section presents a summary of an example of a real system for a power distribution system in a military airplane. The topology of the system is shown in figure 5. The main components of this system are DC/DC converters, protections, filters, hold-up circuits and non-linear loads.

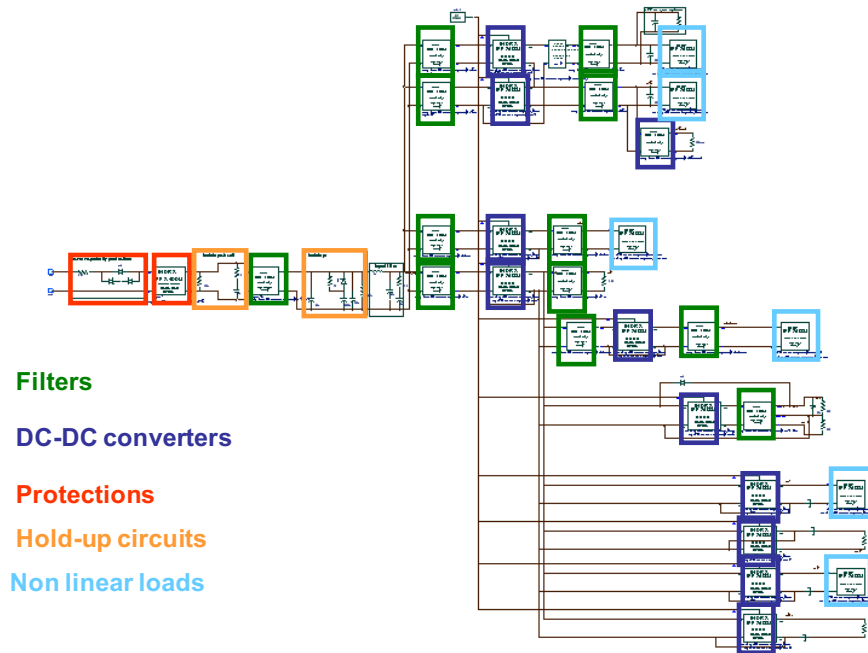

Figure 5 Components of the system that has been analyzed

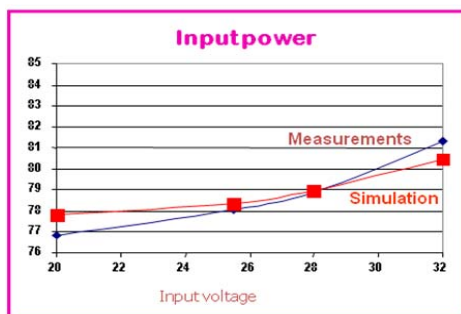

Figure 6 System level validation: power consumption at different input voltages.

Figure 7 and Figure 8 show the influence of the protections on the system stability. Both figures compare the measured and simulated input current under two start-up scenarios. In the first case, the system is powered with minimum input voltage and a bus voltage drop of 0.4V. And it can be seen that the simulation predicts that the systems can start without

The system has been simulated accordingly to the approach described in this work providing excellent results at both, individual elements simulation and system level simulation. Figure 6 shows the power consumption of the system for different input voltages. In this case the system presents does not behave as a constant power source but it has an slight increase of the power with the input voltage. It can be seen that the measurements match pretty well with the simulation results.

problems. In the second scenario, the voltage drop in the bus has been set to 1.5V and it can be seen in Figure 8, how the simulation predicts the instability under this condition. The reason for this not explained by the small signal analysis of the power system but for the undervoltage protection in one of the dc-dc converters.

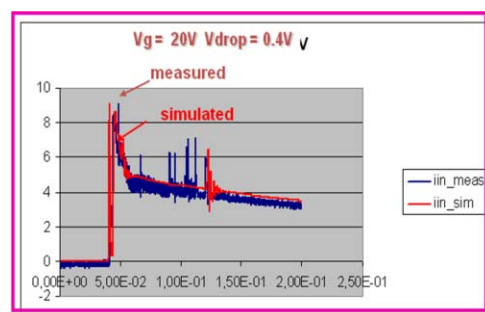

Figure 7 Start-up test under minimum input voltage and bus voltage drop of 0.4V

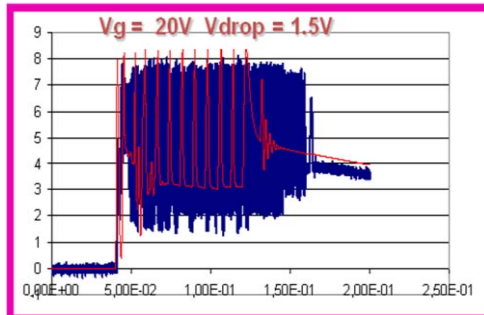

Figure 8 Start-up test under minimum input voltage and bus voltage drop of 1.5V

## 5 Conclusions

The necessity to extensively use simulation for the analysis and design of distributed power system is driven by an increase in the complexity and shorten design cycles. Additionally, the trend toward using commercial components avoids the use of well known modeling techniques such as averaging traditionally used for the analysis of these systems. This work presents a number of recommendations and requirements for the modeling and simulation of systems extracted from the experience obtained in the participation of several projects in this area for the simulation of electronic aerospace systems. These recommendations have been applied to the simulation of real systems providing very helpful information for

their design. Comparisons between measurements and simulation at system level have also been included.

## 6 References

- [1] Milan M. Jovanovic, "Power Supply Technology – Past, Present and Future" Power Conversion and Intelligent Motion China Conf. for Power Electronics (PCIM China), Shanghai, China, March 21-23, 2007, pp. 3-15.
- [2] R. D. Middlebrook, "Input Filter Considerations in Design and Application of Switching Regulators," IEEE IAS Annual Meeting, pp. 336-382, 1976.
- [3] Maksimovic, D.; Stankovic, A.M.; Thottuvelil, V.J.; Verghese, G.C., "Modeling and simulation of power electronic converters," Proceedings of the IEEE , vol.89, no.6, pp.898-912, Jun 2001
- [4] Oliver, J.A.; Prieto, R.; Romero, V.; Cobos, J.A., "Behavioral modeling of dc-dc converters for large-signal simulation of distributed power systems," Applied Power Electronics Conference and Exposition, 2006. APEC '06. Twenty-First Annual IEEE , vol., no., pp. 6 pp.-, 19-23 March 2006
- [5] Arnedo, Luis; Boroyevich, Dushan; Burgos, Rolando; Wang, Fred, "Black-Box Terminal Characterization Models for the Analysis and Simulation of Distributed Power Electronic Systems," Power Electronics Specialists Conference, 2007. PESC 2007. IEEE , vol., no., pp.1968-1973, 17-21 June 2007
- [6] R. A. B. DeCarlo, M.S.; Pettersson, S.; Lennartson, B., "Perspectives and results on the stability and stabilizability of hybrid systems," Proceedings of the IEEE, vol. 88, pp. 1069-1082, 2000.