

**A SYNTACTIC ANALYSIS OF ENGLISH SIMPLE SENTENCE
IN *WUTHERING HEIGHTS* BY EMILY BRONTE**



RESEARCH PAPER

**Submitted as a Partial Fulfillment of the Requirement
for Getting Bachelor Degree of Education
in English Department**

by:

WINARSIH

A 320 070 163

**SCHOOL OF TEACHER TRAINING AND EDUCATION
MUHAMMADIYAH UNIVERSITY OF SURAKARTA**

2011

APPROVAL

**A SYNTACTIC ANALYSIS OF ENGLISH SIMPLE SENTENCE
IN *WUTHERING HEIGHTS* BY EMILY BRONTE**

RESEARCH PAPER

Proposed by:

**WINARSIH
A 320070163**

Approved to be examined by the consultant team:

Consultan I

Consultan II

**Dra. Malikatul Laila, M. Hum.
NIK. 409**

**Drs. Sigit Haryanto, M. Hum.
NIK. 567**

ACCEPTANCE
RESEARCH PAPER
A SYNTACTICAL ANALYSIS OF ENGLISH SIMPLE
SENTENCE IN WUTHERING HEIGHTS BY EMILY BRONTE

By
WINARSIH
A 320 070 163

Accepted by the Board of Examiners
School of Teacher Training and Education
Muhammadiyah University of Surakarta

Team of examiners:

1. **Dra. Malikatul Laila, M. Hum.** ()
(Chair Person)
2. **Drs. Sigit Haryanto, M. Hum.** ()
(Member I)
3. **Dra. Dwi Haryanti, M Hum.** ()
(Member II)

Dean,

Drs. H. Sofyan Anif, M. Si
NIK. 547

TESTIMONY

The writer herewith asserts that there is no work had been submitted to get bachelor degree in any university and as far as the writer concern there is no work or opinion had been written or published by someone else except the written references which are referred in this paper and mentioned in the bibliography.

If only there will be any incorrectness proved in the future in my statement above, I will be fully responsible.

Surakarta, June 2011

The researcher,

Winarsih
A 320 070 163

MOTTO

Intansurulloha yangsurkum wayusabbit akokdaamakum

(QS. Muhammad: 7).

“Apabila kamu sekalian menolong pada agama Allah, maka Allah akan menolong pada mu”.

“The last but not the least”.

“Every cloud has silver lighting”.

DEDICATION

This research paper is dedicated to:

✚ *My beloved Mom and Dad who never stop loving me and giving me supports*

✚ *My beloved sisters and brothers*

✚ *All my family and my friends*

✚ *My self*

ACKNOWLEDGMENT



Assalamu'alaikum wr. Wb.

Alhamdulillahirobbil'alamin, praise and gratitude only to Alloh SWT, the Glorious, The Lord and the All Mighty, the Merciful and the Compassionate, who has given bless and opportunity for the researcher to finish the paper entitled A SYNTACTIC ANALYSIS OF ENGLISH SIMPLE SENTENCE IN *WUTHERING HEIGHTS* BY EMILY BRONTE. Greeting and invocation are presented to the prophet Muhammad SAW who has guided mankind to the right path blessed by the Lord.

The researcher realizes it is impossible to finish the research without any help, support, encouragement, and advice from others. This is because of her limitation. Therefore, the researcher would like to expresses her deepest appreciation and gratitude to persons who have contribution to her to finish the paper, among others are:

1. Drs. H. Sofyan Anif, M. Si as the dean of School of Teacher Training and Education of Muhammadiyah University of Surakarta,
2. Titis Setyabudi, S.S as the head of English Department of Muhammadiyah University of Surakarta,
3. Drs. Abdillah Nugroho, M. Hum as the researcher's academic consultant,

4. Dra. Malikatul Laila, M. Hum as the first consultant who has guided her carefully and patiently. Thanks for advices and supports so that she can finish her study and the research paper,
5. Drs. Sigit Haryanto, M. Hum as the second consultant who has been so patient in giving suggestion for the researcher. Thanks for giving help, advice and guidance, so the researcher is motivated to finish the research paper,
6. Dra. Dwi Haryanti, M. Hum who help the researcher to complete this research,
7. All of lectures of English Department in Muhammadiyah University of Surakarta who has given her knowledge,
8. My lovely **Mom** and **Dad**, thanks a lot for being patient, loving, praying, guiding, and also supporting material and spiritual in which accompanying me in study,
9. My beloved sisters and brothers; “**M. Tie, M. Moel, Utiet & Pleki**” who always gives me motivation and spirit to finish this research,
10. All my families, thanks for your praying,
11. My best friends; “**Exa, Dony, Sys, Ddi**” you open my eyes about this life,
12. My good friends & partners in 7Up EC; “**Daido, Imelda, A'in, Miena, Mamah, Izul**” Thank you because you are my best partners,
13. My friends in “Bu Warini” Boarding House; “**Lien, Erna, Niena, Teaya, Nopex, Lya, Eva, Whildan**” who gives me support. Thank you so much...

14. My partners in LPM CAMPUS;" **Ariant, MoniK, Anton, Mikho, Satiti, Nurlita, Sekar, Sally, Widya, Dwi R, Wafda, Dwi H, Aqlisty, Dian, Dita, Nita, Vita, Dany, Rita, Mifta, Fitri, Lala, Icha**" thanks for your kindness,
15. Junior of LPM CAMPUS crews;" **Mimi, Kamil, Isnani, Wati, Azizah, Hari, Iim, Uut, Suci, Ita, Ulfa, Deny, Pipin, Arsyhan, Agung, Dawud, Rahmad, Nana, Imdad, Asnawi, Aulia, Puspa, Umi, Mitha, Uus, Wiwik, Nisa, Adiguna, Relis, Mamo, Aan, Sofi'I**" good luck...
16. My best friends in "D" class 2007; **Diva, Molen, Wahyu qyu, Lya, Linda, Rini, Hanit, Agus**, and all of my friends that can be mentioned one by one. Keep progressing in your future,
17. All my friends in English Department especially 2007, and
18. The last for all of people that give any contributions in finishing this research.

The researcher realizes the research is far from perfection. Therefore, she would like to send gratitude to the readers who are willing to give input in the form of suggestion or constructive criticism to make the research paper better. The researcher hopes this research paper would be beneficial to everyone.

Surakarta, June 2011

Writer

TABLE OF CONTENTS

TITLES	i
APPROVAL	ii
ACCEPTANCE	iii
TESTIMONY	iv
MOTTO	v
DEDICATION	vi
ANCKNOWLEDGMENT.....	vii
TABLE OF CONTENTS	x
ABSTRACT	xii
CHAPTER I: INTRODUCTION	1
A. Background of the Study	1
B. Previous Study	3
C. Problem of the Study	5
D. Objective of the Study	5
E. Limitation of the Study	5
F. Benefits of the Study.....	6
G. Research Paper Organization	6
CHAPTER II: UNDERLYING THEORY	8
A. Approaches of Syntactic Analysis	8
B. The Notion of Syntactic Structures	11
C. English Sentence Types.....	13
D. Syntax of Structural Grammar	15

E. Wuthering Heights	20
CHAPTER III: RESEARCH METHOD	21
A. Type of Research	21
B. Object of Research	21
C. Data and Data Source	22
D. Method of Collecting Data	22
E. Technique of Analyzing Data	22
CHAPTER IV: DATA ANALYSIS AND DISCUSSION	24
A. Data Analysis	24
1. Subject + Verb	25
2. Subject + Verb + Noun Phrase	29
3. Subject + Verb + Adjective	32
4. Subject + Verb + Noun Phrase + Place	34
5. Subject + Verb + Noun Phrase + Noun Phrase	35
6. Subject + Verb + Noun Phrase + Adjective	36
7. Subject + Verb + to + Base Form of Verb	37
8. Auxiliary + Subject + Verb	39
9. Question Word + Subject + Verb	40
B. Discussion of the Finding	41
CHAPTER V: CONCLUSION AND SUGGESTION	44
A. Conclusion.....	44
B. Suggestion	45
BIBLIOGRAPHY	xiii
APPENDIX	xiv

SUMMARY

WINARSIH. A320070163: A SYNTACTIC ANALYSIS OF ENGLISH SIMPLE SENTENCE IN *WUTHERING HEIGHTS* BY EMILY BRONTE. RESEARCH PAPER. MUHAMMADIYAH UNIVERSITY OF SURAKARTA. 2011

This study is aimed to identify the patterns of syntactic structure of English simple sentence and to describe the syntactical constructions of the simple sentence used in *Wuthering Heights* by Emily Bronte.

The type of this research is descriptive qualitative. The data source of this research is *Wuthering Heights*. The method of collecting data is documentation and the steps are reading, underlying, rewriting and coding the data. The techniques of analyzing data are identifying the patterns of syntactic structure and syntactical constructions of simple sentence by structural approach. The analysis of the pattern is based on classification of sentences, especially the types of sentences. While the analysis of the syntactical constructions of simple sentence is based on Chinese Box.

The results show that the patterns of syntactical constructions of simple sentence in the novel are:

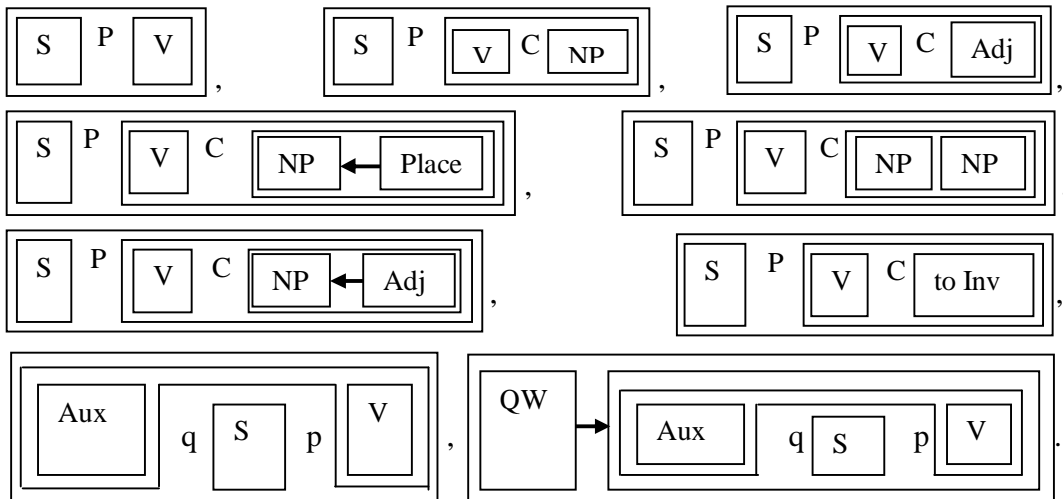

Key Words: *Syntax, and Simple Sentence.*

Consultant I

Consultant II

Dra. Malikatul Laila, M. Hum

Drs. Sigit Haryanto, M. Hum

Dean,

Drs. H. Sofyan Anif, M.Si