

A Confirmatory Factor Analysis on Task-Technology Fit for a Student Portal

Norshidah Mohamed
International Business
School
Universiti Teknologi
Malaysia
norshidah@ic.utm.my

Muna Azuddin
Department of
Information Systems
International Islamic
University Malaysia
munaazuddin@gmail.com

Nor Shahriza Abdul Karim
International Business
School
Universiti Teknologi
Malaysia
nshahriza@ic.utm.my

Ramlah Hussein
School of Computer
Technology
Sunway University
ramlahh@sunway.edu.my

Abstract—This research seeks to identify the predictors of task-technology fit in the context of student portal. The population comprises undergraduate students who are registered and active at three faculties in a public institution of higher learning in Malaysia. The sample is 570 students drawn using cluster sampling approach based on courses offered according to the level of study at each faculty. The study adapted six measures from past e-commerce study and found five predictors of task-technology fit.

Keywords—Task-Technology Fit, Confirmatory Factor Analysis, Portal, Structural Equation Modeling

I. INTRODUCTION

Technology advances have given rise to information overload for individuals, organizations and institutions. In a rapidly changing environment, individuals now require a technology enabler to assist them in finding the right information for the tasks that they need to perform quickly. At the same time, the new millennium sees more and more individuals getting connected over the Internet. A *portal* appears to be the means to this end.

According to Clarke and Flaherty (2003), the word *portal* is derived from the Latin word *porta* which means something that will be passed in order to get to another place. A Web-based portal functions to assist Web users by leading them to the ultimate location of their choice (Clarke and Flaherty, 2003). Krishnamurthya and Chan (2005) defined a portal as a system that gathers a variety of useful information resources into a single one-stop Web page. This allows its users to customize their information sources by selecting and viewing information they find personally useful.

In this paper, the research question has been formulated as follows: **What are the predictors of Task-Technology Fit for a student portal?** Hence, the aim of this paper is to present a confirmatory factor of Task-Technology Fit in the context of student portal in a Malaysian institution of higher learning to answer the research question. In confirmatory factor analysis, the aim is to statistically test the significance of the hypothesized factor model i.e. whether the sample data

confirm the model while assessing the convergent validity.

This section has introduced the research background. Section two presents the literature review. In section three, we discuss the methodology. The findings are provided in section four while the last section concludes the paper.

II. LITERATURE REVIEW

Goodhue and Thompson (1995) developed the Task-Technology Fit model to measure the degree to which a technology assists users in performing their tasks. A high task-technology fit increases both the chances that a technology will be utilized and contributes to users' performance. Three factors i.e. task, technology and individual were suggested as affecting the task-technology fit. A better fit between technology functionalities, task requirement and individual abilities will lead to users' better performance. Researchers have applied the Task-Technology Fit model to measure users' perception (Klopping and McKinney, 2004; McGill and Klobas, 2009; Schrier et al. 2010).

Klopping and McKinney (2004) investigated the task-technology fit on consumers' online shopping attitude and found that task-technology fit was strongly associated with perceived usefulness of e-commerce. McGill and Klobas (2009) investigated task-technology fit in Learning Management System (LMS) and reported that it is an influencing factor in expected consequences of LMS use, attitudes towards LMS use, perceived impacts on students' learning and students' grades. Schrier et al. (2010) conducted a study on hotel guests' experiences using guest empowerment technology (GET). In the hotel industry, these technologies typically include systems such as in-room check-out systems, in-room entertainment systems, on demand printing services, lobby kiosks, and online reservation systems (Schrier et al., 2010). They found that task and technology characteristics are positively and significantly related to fit while users' experiential characteristics are negatively and significantly associated to fit. Task-technology fit is a predictor of

perceived usefulness and ease of use (Schrier et al., 2010).

III. METHODOLOGY

A. Context of Study

The study was conducted with students as research participants at a public institution of higher learning in Malaysia. The study seeks to evaluate the capabilities of the university's student portal whether they match the tasks that the students must perform. The university has adopted a Web-portal to manage the information and knowledge among students, academic personnel and administrative personnel since 2006. It was developed and is currently managed by the university's Information Technology Division. The student portal implementation was made in two stages i.e. the first phase was commissioned in August 2006 for students and the second phase was in November 2006 for university's personnel.

B. Population and Sampling

In this study, the population refers to undergraduate students who are registered and active at three faculties in a public institution of higher learning in Malaysia. We estimate that the population is approximately 8,000. The sample is 570 students drawn using cluster sampling approach based on courses offered according to the level of study at each faculty.

C. Instrument

The measures used for the research were adapted from Klopping and McKinney (2004). Table 1 shows the measures.

Students were asked to evaluate the task-technology fit of the university's student portal using five point-Likert scale for each item of the questionnaire where 1 refers to strongly disagree and 5 refers to strongly agree.

We conducted a pilot test of the questionnaire for a particular course. No modifications were made on any of the six items. We then distributed the questionnaires to students of other courses.

D. Strategy for data collection

The researchers strived to maximize the response rate. In doing so, the researchers contacted the respective lecturers of identified courses via e-mail. When an approval is obtained, the researchers distribute the questionnaires prior to the start of a class at an agreed time. Students were briefed about the objective of the research and given 15 minutes to complete the questionnaires. They were assured that responses would be treated in confidence.

E. Data analysis approach

Data was first analyzed using descriptive analysis to gain insights into the profile of respondents. The

researchers used SPSS version 16 for this purpose. Following that, the researchers used Amos version 16 to analyze the confirmatory factor model.

TABLE I. MEASURES

Code	Item Descriptions
Task1	Sufficiently detailed student information is maintained in the Student Portal.
Task2	Information about services for students is obvious in the Student Portal.
Task3	I can get information about services for students quickly and easily from the Student Portal when I need it.
Task4	The information about services for students that I need is displayed in a readable and understandable form in the Student Portal.
Task5	The information about services for students maintained in the Student Portal is what I need to carry out my tasks as a student.
Task6	The information about services for students is stored in so many forms in the Student Portal that it is hard to know how to use it effectively.

IV. FINDINGS

Fig. 1 shows the confirmatory factor model results for task-technology fit of the study.

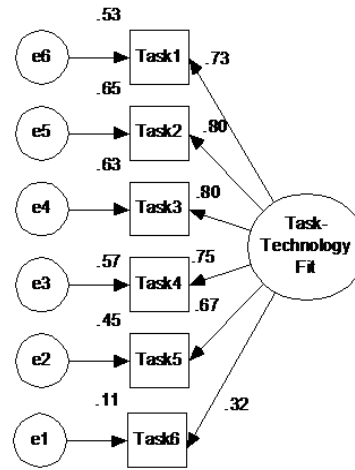

Figure 1. Confirmatory factor analysis for task-technology fit.

Convergent validity is established if the loadings of the measures to their respective constructs are at least 0.60 (Bagozzi and Yi, 1988). In structural equation models, the reliability of parameters is defined as the magnitude of the direct effects that the latent variables exert on the indicators. This is determined by means of the square multiple correlations of each indicator and the total coefficient of determination (Bollen, 1989). Further, all squared multiple correlations (R-square) must be at least 0.40 (Bollen 1989). Based on Fig. 1, the items had loadings within the range from 0.32 to 0.80. The square multiple correlations are between 0.11 and 0.65.

The evidence suggests that all items except *Task6* meet the cut-off point and have good construct validity. Table 2 shows the analysis by loading, squared multiple correlations by each item description in descending order of factor loading and squared multiple correlations.

TABLE II. ANALYSIS BY ITEM DESCRIPTIONS

Item Descriptions	Factor loading	Squared-multiple correlations
Information about services for students is obvious in the Student Portal. (<i>Task 2</i>)	0.80	0.65
I can get information about services for students quickly and easily from the Student Portal when I need it. (<i>Task 3</i>)	0.80	0.63
The information about services for students that I need is displayed in a readable and understandable form in the Student Portal. (<i>Task 4</i>)	0.75	0.57
Sufficiently detailed student information is maintained in the Student Portal. (<i>Task 1</i>)	0.73	0.53
The information about services for students maintained in the Student Portal is what I need to carry out my tasks as a student. (<i>Task 5</i>)	0.67	0.45
The information about services for students is stored in so many forms in the Student Portal that it is hard to know how to use it effectively. (<i>Task 6</i>)	0.32	0.11

The evidence further suggests that all items except *Task6* are predictors of task-technology fit. The top three predictors are highlighted in bold in Table II. Sixty-five percent of the variance of *Task2* accounts for task-technology fit. The remaining 35% of the variance is attributed to the unique factor *e5*. This finding is consistent with Klopping and McKinney (2004) in that all measures except *Task6* (The information about services for students is stored in so many forms in the Student Portal that it is hard to know how to use it effectively) were contributors of task-technology fit. This suggests that for students to perceive the student portal fit to their needs that considerations must be given to information being presented in obvious format, information that is easy and quick to be accessed, information that is readable and understandable, information that is detailed and relevant to the needs of students. Hence, Web developers and designers need to place considerable importance on these aspects of information services when engaged in implementation of a student portal. The researchers further investigated the goodness of fit indices (Table III) and made a comparison before and after the modification indices (MI) were examined. In doing so, the researchers first removed *Task6* from

further analysis and reviewed the goodness of fit indices. The modification indices suggest a modification index of 21.4 between *e2* and *e3*. Although Byrne (2010) suggested error covariance as little concerned, the researchers made a correlation between the two error terms. This significantly improved the RMSEA and PCLOSE values.

TABLE III. COMPARISON OF GOODNESS OF FIT INDICES

Fit measure	Recommended value	Value for the research model	
		Before MI	After MI
χ^2		56.01	15.22
Degrees of freedom (df)		9	4
χ^2/df	<3	6.22	3.81
p-value	>.05	.00	.00
GFI	>.90	.96	.99
Adjusted GFI	>.90	.91	.96
Normed fit index (NFI)	>.90	.95	.99
Relative fit index (RFI)	>.90	.92	.97
Incremental fit index (IFI)	>.90	.96	.99
Tucker Lewis index (TLI)	>.90	.93	.97
Comparative fit index (CFI)	>.90	.96	.99
Root mean square error of approximation (RMSEA)	<.08	.11	.07
Closeness of fit (PCLOSE)	>.05	.00	.12
Root mean square residual (RMR)	<.08	.02	.01

V. CONCLUSION

The paper began with the following research question: ***What are the predictors of Task-Technology Fit for a student portal?*** The paper has presented a confirmatory factor analysis of Task-Technology Fit in the context of student portal in a Malaysian institution of higher learning. The research has shown that there is evidence to support prior research. The research has added to new knowledge that the Task-Technology Fit model is valid and reliable in the context of student portal in a higher education environment. In terms of practice, the instrument could be applied to measure the task-technology fit of student portal in Malaysia. The confirmatory factor analysis results provided a basis for future works in addressing measurements for task-technology fit and in examining structural model. However, the research presents limitations that should be acknowledged. The research used cross-sectional approach. Further, as only undergraduates participated

in the research, the findings may not be generalized in the context of the entire institution and thus may have to be carefully interpreted. Future research may consider longitudinal approach and postgraduates as research participants.

ACKNOWLEDGMENT

We appreciate the commitment of lecturers whose students participated in this research.

REFERENCES

- [1] R. P. Bagozzi, and Y. Yi, "On the evaluation of structural equation models", *Journal of the Academy of Marketing Science*, vol. 16, no. 1, pp. 74-94, 1988.
- [2] K. A. Bollen, *Structural Equations with Latent Variables*. New York: John Wiley and Sons, 1989.
- [3] B. M. Byrne, *Structural Equation Modeling with Amos*. New York: Routledge, 2010.
- [4] I. Clarke and T. B. Flaherty, "Web-based B2B portals", *Industrial Marketing Management*, vol. 32, no. 1, pp.15-23., 2003.
- [5] D. L. Goodhue and R. L. Thompson, "Task-Technology Fit and Individual Performance", *MIS Quarterly*, vol. 19, no. 2 (June), pp. 213-236, 1995.
- [6] I. M. Kloppping and E. M. McKinney, "Extending the technology Acceptance Model and the Task-Technology Fit Model to consumer e-commerce", *Information Technology. Learning and Performance Journal*, vol. 22, no. 1, pp. 35-4, 2004.
- [7] M. Krishnamurthya and W. S. Chan, "Implementation of library portals for information resources: A case study of the Indian Statistical Institute, Bangalore (ISIB)", *The International Information & Library Review*, vol. 37, no. 1, pp. 45-50, 2005.
- [8] T. J. McGill and J. E. Klobas, "A task-technology fit view of learning management system impact. *Computers and Education*, vol. 52, no. 2, pp. 496-508, 2009.
- [9] T. Schrier, M. Erdem and P. Brewer,. "Merging task-technology fit and technology acceptance models to assess guest empowerment technology usage in hotels", *Journal of Hospitality and Tourism Technology*, vol. 1, no. 3, pp. 201-217, 2010.