

The scheme of combined application of optimization and simulation models for formation of an optimum structure of an automated control system of space systems

A S Chernigovskiy¹, R Yu Tsarev¹, A Yu Nikiforov¹, P V Zelenkov²

¹Siberian Federal University, Krasnoyarsk, Russia

79, Svobodny Prospect, Krasnoyarsk, Russia

²Siberian State Aerospace University named after Academician M.F. Reshetnev

31 “Krasnoyarskiy Rabochiy” prospect, Krasnoyarsk, 660014, Russia

E-mail: achernigovskiy@sfu-kras.ru

Abstract. With the development of automated control systems of space systems, there are new classes of spacecraft that requires improvement of their structure and expand their functions. When designing the automated control system of space systems occurs various tasks such as: determining location of elements and subsystems in the space, hardware selection, the distribution of the set of functions performed by the system units, all of this under certain conditions on the quality of control and connectivity of components. The problem of synthesis of structure of automated control system of space systems formalized using discrete variables at various levels of system detalization. A sequence of tasks and stages of the formation of automated control system of space systems structure is developed. The authors have developed and proposed a scheme of the combined implementation of optimization and simulation models to ensure rational distribution of functions between the automated control system complex and the rest of the system units. The proposed approach allows to make reasonable hardware selection, taking into account the different requirements for the operation of automated control systems of space systems.

1. Introduction

The automated control systems of space systems represent hierarchical multi-function and multi-loop complexes with advanced means of communication between the control units. They include a set of ground measuring stations of different types, distributed over large areas, the communication channels providing information transfer between system elements, control units and communication units of different hierarchy levels.

The emergence of new classes of spacecrafts and the expansion of their functions require enhancement of structure of automated control systems of space systems (ACS of SS). Designing such systems include determination of elements and subsystems of ACS of SS in space, the selection of a hardware complex, that provide execution of control functions taking into account spatial placement of the complex [1] and accessibility of its units, distribution of executed functions set on system units taking into account correlation on technology of information processing and control [2]. At the same time, system controlling quality requirements must be provided.

2. Problem statement

In case of the synthesis of structure of ACS of SS there are tasks of rational distribution of functions between the controlling complex and remaining units of the system, the task of a hardware selection in units of system and communication channels in between taking into account different tactic-technical and techno-economic requirements to functioning of ACS of SS [3]. At the same time, emerging mathematical problem formulation of system structure synthesis can be formalized with use of the discrete variables at various levels of system detalization. It is necessary to determine the sequence of

tasks and stages of structure creation of ACS of space system and to solve the problem of a selection of control units of ACS of space system due to combined implementation of optimization and simulation models.

3. Solution procedure

The sequence of tasks and stages of structure formation of ACS of SS is shown in Fig. 1. At the initial stages requirements [4] to the developed ACS of SS are formulated, the composition of characteristics and efficiency criteria of system structure options is selected. The possible composition of units, options of their construction and territorial placement, and also the characteristic of these options are defined. Control functions in system, which are detailed to the complex of interdependent control tasks and versions of their solution (or to variants of creation of processing procedures of information and information arrays) that provide execution of the given control functions (Fig. 1) are selected.

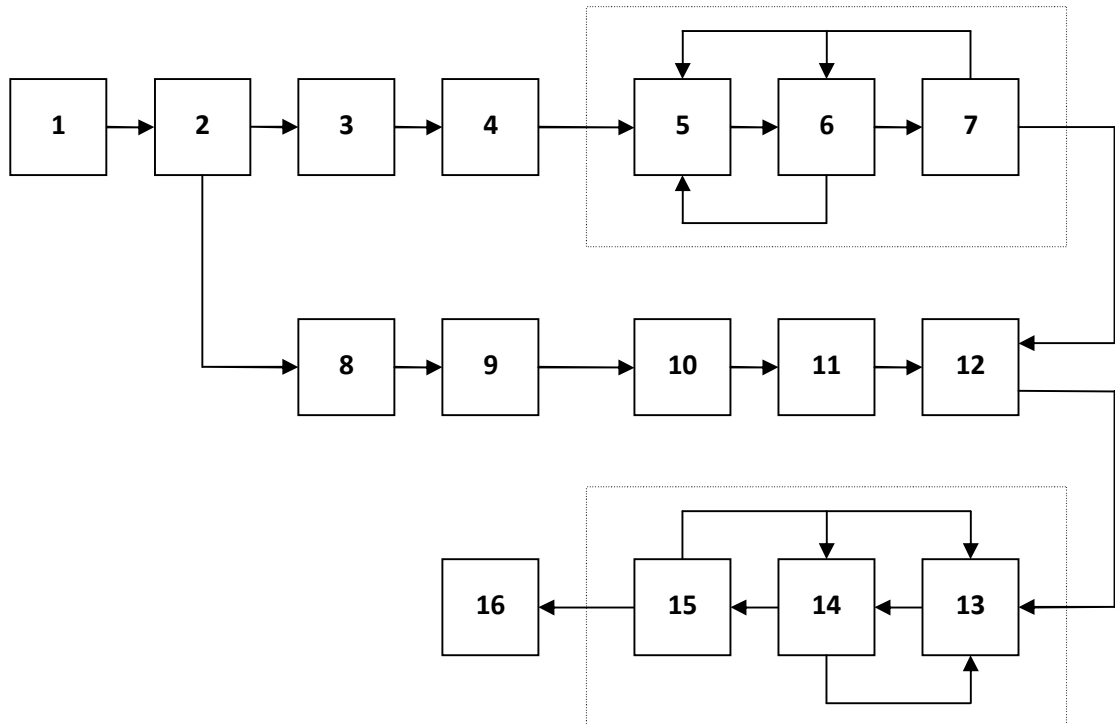

Figure 1. The sequence of tasks and stages of ACS of space system structure formation

The sequence of tasks and stages of structure formation of ACS of space system shown in fig. 1:

- 1) formulation of the problem of ACS of space system structure formation;
- 2) specification and selection of composition of the considered characteristics and efficiency criteria of structure options;
- 3) determination of possible composition of control units and their correlations;
- 4) formalization of topological structure construction options of the system (creation of a graph of interdependent control tasks set which are carried out by ACS of SS, G_J);
- 5) optimization model of topological structure (selection of $G_J^* \subset G_J$);
- 6) simulation model of topological structure of ACS of space system;
- 7) analysis and decision correction unit;
- 8) determination of control tasks functions composition and their correlations;
- 9) determination of control tasks and functions options of execution;
- 10) determination of a possible hardware set for control functions and tasks execution;
- 11) formalization of options of functions and tasks execution (making of a graph of topological structure of ACS of SS reflecting a set of possible options of creation and spatial placement of the controlling units of system and communication links in between, G_J);

- 12) formalization of creation of the functional structure of ACS of space system (making of map G_f on G_j);
- 13) optimization model of the system functional structure;
- 14) simulation model of the system functional structure;
- 15) analysis and decision correction unit;
- 16) receiving an optimal alternative of system structure.

Further the selected formation options of interdependent control tasks complex and control units formation options (including hardware controls equipment options) are formalizing in the form of graphs G_f and G_j , which serve as the basis for the formalized stages of the synthesis of the topological and functional structure of the system (highlighted blocks 5-7, 13-15 in Fig. 1).

The considered tasks can be formalized using graph [5] and mapping apparatus. The general diagram of structure formation of ACS of SS includes the following stages:

- 1) formation of the topological structure graph of ACS of KC G_f , that maps the a set of possible options of formation and spatial placement of the controlling units of the system and communication links in between;
- 2) formation of a graph of interdependent set of control tasks of G_f which are carried out by KS ACS;
- 3) formalization of map of the graphs G_f on G_j .

Thus, the task of synthesis of topological structure of system is search of an optimum subgraph on the G_j graph of the ACS of SS units, and the task of synthesis of the functional structure – in search of optimum mapping of the graph G_f to the graph G_j of topological structure of system.

For ACS of SS it is expedient to select the following detalization levels of creation of system:

- a selection of composition and topology of control ground stations (the aggregated variable X);
- a selection of security option of control points from external influences and a hardware complexes selection at units (the aggregated variable Y);
- a selection of option of distribution of functions and control tasks between the selected control units and hardware (the aggregated variable Z).

At the same time the general task of structure formation of ACS of KS can be represented as follows [6]:

$$\begin{aligned} \text{extr } F(X, Y, Z) &= f_1(X) + f_2(X, Y) + f_3(X, Y, Z); \\ X &\in G_1, Y \in G_2(X), Z \in G_3(X, Y), \end{aligned}$$

where $X = \{x_j\}$, $Y = \{y_{jk}\}$, $Z = \{z_{ijk}\}$ – bool vectors, interconnected as follows: for each $j \in J$, $k \in K$, $i \in I$; $y_{jk} \geq 0$, if $x_j > 0$; $y_{jk} > 0$, if $x_j = 0$; $z_{ijk} \geq 0$, if $y_{jk} > 0$; $z_{ijk} = 0$, if $y_{jk} = 0$.

It is possible to notice, that generally some limitations of the task can be set algorithmically that requires, in turn, the organization of iterative diagrams of the decision of the specified tasks taking into account iterations of the solving of the general task of structure formation of ACS of SS. In practice such difficult procedures are implemented in the form of the human-machine diagrams of synthesis including possibilities of "the designer of system" in the dialog mode to interfere and adjust results of the intermediate decisions and the process of optimization.

The complex of interdependent models and algorithms and iterative diagrams of their interaction in case of synthesis of a topological (spatial) and functional structure of system (fig. 2) is developed for the solution of problems of synthesis of structure of distributed ACS of SS on the basis of methodology of difficult systems structure synthesis.

At the first stage of ACS of SS synthesis (unit 1) the problem of selection of composition and spatial location of control units taking into account costs of their organization, accessibility and globality of control of different classes of the spacecrafts is solving.

It is supposed that in the given territory the set of points included in ACS of SS in which the control units directly interacting with spacecraft can be created is defined. Visibility ranges of different control units break projections of spacecraft motion paths to sections. Set of sections of different points determines accessibility of spacecraft by control units and globality of ACS of SS. The task of structure synthesis of ACS of SS is in the selection of set of control units, minimizing costs of their creation on condition of fulfillment of requirements to globality of control for each class of spacecraft and some other requirements, for example, quantity of the nodes interacting with each class of objects, etc.

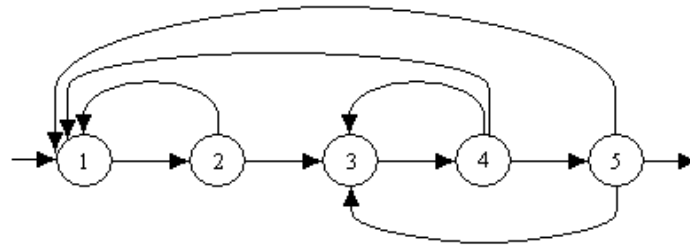

Figure 2. Diagram of combined implementation of optimization and simulation models for a selection of control units

Simulation models [7-8] of interaction of elements of the given topological structure are intended for determination algorithmically given characteristics of functioning of the synthesized option of ACS of SS structure (unit 2). The model allows to analyze functioning of system with different number and layout of ground control stations, different quantity of spacecraft classes and number of spacecrafts in each class, different number of types of the controlling interactions between control centers and spacecrafts. As a result of simulation efficiency characteristics of operation of ground control stations (the general loading, loading by types of interaction and spacecrafts classes) and control quality of spacecrafts of different classes set (number of interactions, their duration, number of unrealized interactions, etc.) are determined.

In units 3, 4 for the selected set of control units and their correlations the options of creation of nodes and communications in between providing increase in survivability of the system determined by probability of execution by system of functions of control taking into account possible adverse external effects are defined.

Different options of creation of the ACS of SS units and communications in between directed to increase in survivability of system are formalized in the form of the graph G_j . For increase in survivability duplicating of nodes and communication links, increase in security of nodes, etc. are used. Each option of creation of nodes or communication links is characterized by costs of their implementation and probability of failure for the considered time interval. For each class of objects the minimum set of nodes which functioning provides execution of the given functions of control is set. It is supposed that such set are the elements connecting an object to command center.

The task of determination of options of creation of ACS of SS consists in minimization of costs of the actions providing execution with system of functions of control in case of the restrictions characterizing survivability of control system for different classes of objects [9].

Such selection occurs as a result of implementation of the analytic-simulative procedure that executes interaction during the synthesis of optimization selection model of a system elements implementation (unit 3) and a simulation model (unit 4).

The complex of simulation models is intended for the detail accounting of probable characteristics of functioning of the generated options of creation and support of survivability of system (unit 4) which allows to analyze functioning of system in case of different values of intensity and for different probability distributions of system elements failure (control units, communication channels, etc.).

According to the general methodology of synthesis of complex systems structure, generation of options for their detail analysis and a selection is carried out by means of optimization models (unit 3). At the same time, the following values are assumed set: $P_{ik}(k = \overline{1, K_i}, i = \overline{1, I})$, $P_{jk}(k = \overline{1, K_j}, j = \overline{1, J})$, $P_{Rk}(k = \overline{1, K_R})$ – probabilities of reliable functioning of k -th option of i -th object organization, j -th unit of the ACS of SS, R -th repeater for the considered time interval taking into account adverse external effects; the $j = 0$ index corresponds to central control unit, and $j = \overline{1, J}$ indexes – sets of ground control units; P_{ijk} , P_{iRk} , P_{Rjk} , P_{j0k} – probabilities of successful functioning of constructing options of communication links between an object and a ground control unit, an object and repeaters, repeaters and a ground control unit, a ground control unit and central unit for the considered time interval taking into account adverse effects; C_{ik} , C_{jk} , C_{Rk} , C_{ijk} – costs of organization options for objects construction options, repeaters, central unit and communication channels, ground control units.

The task of selection of options of the ACS of SS elements composition is in cost minimization:

$$\min \left(\sum_{\alpha} \sum_k C_{\alpha k} + \sum_{\beta} \sum_k C_{\beta k} x_{\beta k} \right)$$

subject to

$$\begin{aligned} & P_{i0}(x_{ik}, x_{0k}) \left(P_{Rk}(x_{Rk}, x_{iRk}) (1 - P_{ijk}(x_{ijk}, x_{Rjk}, x_{jk})) \right) + \\ & + (1 - P_{Rk}(x_{Rk}, x_{iRk})) (1 - P_{ij}(x_{ijk}, x_{jk})) \geq P_i^{\text{non}}, i = \overline{1, I}; \\ & \sum_k x_{\alpha k} = 1, \alpha = i, j, R; \\ & \sum_k x_{\beta k} = 1, \beta = \{iR, ij, jR, j0\}, \end{aligned}$$

where $x_{ik} = 1$, if k option of i object formation is chosen; $x_{jk} = 1$, if k -th construction option of j -th unit is chosen; $x_{Rk} = 1$, if k -th option of repeater construction is chosen; $x_{imk} = 1$, if k -th communication option between i and j , i and R , R and j , j and 0 (central control unit) elements is chosen respectively; $x_{ik} = x_{jk} = x_{Rk} = x_{imk} = 0$ – otherwise.

Values P_{i0} , P_{Rk} , P_{ijk} , P_{ij} calculated by the following expressions:

$$\begin{aligned} P_{i0}(x_{ik}, x_{0k}) &= \left(\sum_k P_{ik} x_{ik} \right) \left(\sum_k P_{0k} x_{0k} \right); \\ P_{Rk}(x_{Rk}, x_{iRk}) &= \left(\sum_k P_{Rk} x_{Rk} \right) \left(\sum_k P_{iRk} x_{iRk} \right); \\ P_{ij}(x_{ijk}, x_{jk}) &= \prod_j \left[1 - \left(\sum_k P_{ijk} x_{ijk} \right) \left(\sum_k P_{jk} x_{jk} \right) \right]; \\ P_{ijk}(x_{ijk}, x_{Rjk}, x_{jk}) &= \prod_j \left[1 - \left(1 - \sum_k P_{ijk} x_{ijk} \right) \left(1 - \sum_k P_{jk} x_{jk} \right) \right]. \end{aligned}$$

For the task solving it is offered to use the algorithm based on a "branch-and-bound" method [10]. For the purpose of abbreviation of dimensionality of the task on the graph G_j of options of creation of nodes of system and their correlations separation of sequential sections, determination of the aggregated options of creation of the selected sections and their characteristics is provided. At the same time the aggregated options of sections over which remained dominate are excluded from the graph G_j .

At the subsequent stage of synthesis (unit 5) for the found set of the ACS of SS units that work with objects of different classes, and specified control functions on each class of objects optimum allocation of tasks of interdependent subsystems is determined by levels and units of system and the composition of hardware complex is selected. Control functions are set in the form of a set of the tasks which are carried out by different subsystems (circuits) of control.

The typical control subsystem of ACS of SS is intended for execution of the sequence of interdependent functions (tasks) on measurement, transmission and information processing about set of the spacecraft controlled parameters, framing of the controlling influences and to monitoring over their implementation [11]. The problem is in optimization of distribution of the tasks entering a control circuit on levels and the controlling units of ACS of SS and determination of a hardware set that minimize costs of hardware equipment of units and their maintenance in case of execution of restrictions on efficiency, the hardware reliability of control tasks execution, weight and energy consumption of an onboard equipment, units loading, etc.

Options of distribution of functions and tasks on levels and the ACS of SS units are formalized in the form of set of the interdependent graphs G_0 . A specificity of ACS of SS is the way that each individual graph corresponds to a construction option of the corresponding system control circuit. The subgraph, consisting of a set of paths of graphs, sets structure of all system.

4. Conclusion

Thus, within unified approach defines the tasks and stages of the ACS of SS structure formation, including the solutions to interrelated problems of formation of the basic system elements and parts, as well as the selection of a rational option of the structure created by automation space system. The carried-out task analysis of structure formation of ACS of space system showed that it is expedient to select the following detail levels of creation of system:

- a selection of composition and topology of ground control stations;
- a selection of protection from external influences;
- a selection of hardware complexes on the ACS units of space system;
- a selection of option of distribution of functions and control tasks between the selected control units and hardware.

The diagram of combined implementation of optimization and simulation models is developed for the solving of the selection task of control units of ACS of space system. Such diagram allows to use effectively specified models within uniform optimization and simulative approach to structure formation of ACS of space systems that provides rational distribution of functions between the controlling ACS complex and remaining units of the system, and also allows to carry out a reasonable selection of hardware taking into account different requirements to functioning of ACS of space systems.

5. References

- [1] Zelenkov P V, Karaseva M V, Tsareva E A, Tsarev R Y 2015 Definition of the topological structure of the automatic control system of spacecrafts *IOP Conference Series: Materials Science and Engineering* **70** art. no. 012013
- [2] Ding K, Zhu K, Chen, S, Tian, Z 2015 Research and application of space-ground network technology *ICEIEC 2015 - Proceedings of 2015 IEEE 5th International Conference on Electronics Information and Emergency Communication* (Beijing) pp 444-447
- [3] Ting C, Mahfouf H M, Nassef A, Linkens D A, Panoutsos G, Nickel P, Roberts A C, and Hockey G R J 2010 Real-time adaptive automation system based on identification of operator functional state in simulated process control operations *IEEE Transactions on Systems, Man, and Cybernetics Part A: Systems and Humans* **40** 251-262
- [4] McGranaghan M and Goodman F 2005 Technical and system requirements for advanced distribution automation *18th International Conference and Exhibition on Electricity Distribution* **5** 93
- [5] Zhou G, Feng W, Zhao Q and Zhao H 2015 State tracking and fault diagnosis for dynamic systems using labeled uncertainty graph *Sensors (Switzerland)* **15** 28031-28051
- [6] Shipley M F, de Korvin A and Obid R. 1991 A decision making model for multiattribute problems incorporating uncertainty and bias measures *Computational Operations Research* **18** 335-342
- [7] Kleijnen J P C 1979 Regression metamodels for generalizing simulation results *IEEE Trans. on Systems, Man and Cybernetics* **2** 93-96.
- [8] Kleijnen J P C 1995 Verification and validation of simulation models *European Journal of Operational Research* **82** 145-162.
- [9] Van Groenendaal, Kleijnen J P C 1997 On the assessment of economical risk: factorial design versus Monte-Carlo methods *Journal of Reliability Engineering and System Safety* **57** 103-105
- [10] Hendy M D and Penny D 1982 Branch and bound algorithms to determine minimal evolutionary trees *Mathematical Biosciences* **59** 277-290
- [11] Wang Y, Zhao Y, Shi P and Zheng H 2015 Adaptive control for stabilizing the coupling system with disturbance after capturing spacecraft *Chinese Space Science and Technology* **35** 20-28