

NEW GENERATION OF A HIGHLY COMPACT SOLAR HEAT PUMP SYSTEM WITH BOOSTED ENERGETIC EFFICIENCY

I. Mojic¹; M.Y. Haller¹; B. Thissen²; F. Hengel³, A. Heinz³

1: *Institute for Solar Technology SPF, HSR University of Applied Sciences, Oberseestrasse 10, CH-8640 Rapperswil, +41 55 222 41 62*

2: *Energie Solaire S.A., Rue des Sablons 8, Case postale 353, CH-3960 Sierre*

3: *Institute of Thermal Engineering IWT, Graz University of Technology, Inffeldgasse 25B, A-8010 Graz*

ABSTRACT

In this work a new highly compact solar thermal heat pump system for space heating and domestic hot water preparation will be presented in detail. It was developed within the European project “MacSheep”. The aim of the project is to build four different solar heat pump systems, which achieve 25 % electric energy savings compared to the state of the art solar heat pump heating systems, while still being cost-competitive. Within the MacSheep project, four different developing groups developed different system concepts to reach this project goal. The system, which is presented in this paper, was developed and designed by the following partners; Energie Solaire SA (industrial partner), Institute of Thermal Engineering (research partner) and the Institute for Solar Technology SPF (research partner).

A key component of the system is a novel brine-to-water heat pump prototype with a speed controlled compressor, an economizer refrigerant cycle and a desuperheater. The heat pump was optimized for low source temperatures, in order to be compatible with concepts that use only unglazed selective collectors as heat source. A key element was the integration of heat pump, storage, and hydraulic connections into one compact system design. Further developments are: a combi-storage, which is optimized for heat pump use, and selective unglazed collectors with a new selective coating. The compact designed heat storage, heat pump and hydraulic solution is placed under one high performing insulating shell built of vacuum insulation panels.

The annual simulation results, which were validated with component tests in the lab, show very promising results for the whole system. The electric savings compared with the state of the art system are expected around 28 % and the improvement of the seasonal performance factor (SPF) of the whole system is around + 40 %. These values will be compared with a whole system hardware in the loop benchmark test in autumn 2015.

Keywords: Solar, Heat Pump, Vacuum Insulation Panels, Desuperheater, Economizer

INTRODUCTION

Within the European project “MacSheep” four developing groups, made up of different research institutes and private companies, have developed each a solar heat pump system for space heating and domestic hot water preparation. The aim was to achieve 25 % electric energy savings, compared to what was the state of the art for solar and heat pump systems at the beginning of the project in 2012. At the same time, the aim was to achieve this without an increase in system cost. In this paper we will present the developed system of one of the four groups, which is represented by the authors of this work.

The newly designed system consists of the following improved or newly developed components:

- variable speed heat pump (HP) with economizer and desuperheater cycle, developed by IWT,
- unglazed selective solar absorbers with new coating that leads to significant cost savings (heat source for the heat pump), developed by Energie Solaire SA,
- thermal combi-storage optimized for heat pump use, featuring enhanced stratification even with high inlet mass flows, developed by SPF,
- high efficiency storage insulation built with vacuum insulation panels (VIP), by SPF,
- hydraulics and control solution that allows the heat pump to serve directly space heating without using the storage for most of the year – compatible with all kinds of heat distribution systems, developed jointly by SPF and IWT.

Unique on this system is that all hydraulic components such as pumps, valves, heat exchangers and the heat pump itself are under the same VIP insulation as the storage unit. Thus, a very compact system can be built with a high degree of pre-fabrication, resulting in much faster and less fault-prone installation in the field. Figure 1 shows the design concept of the system.

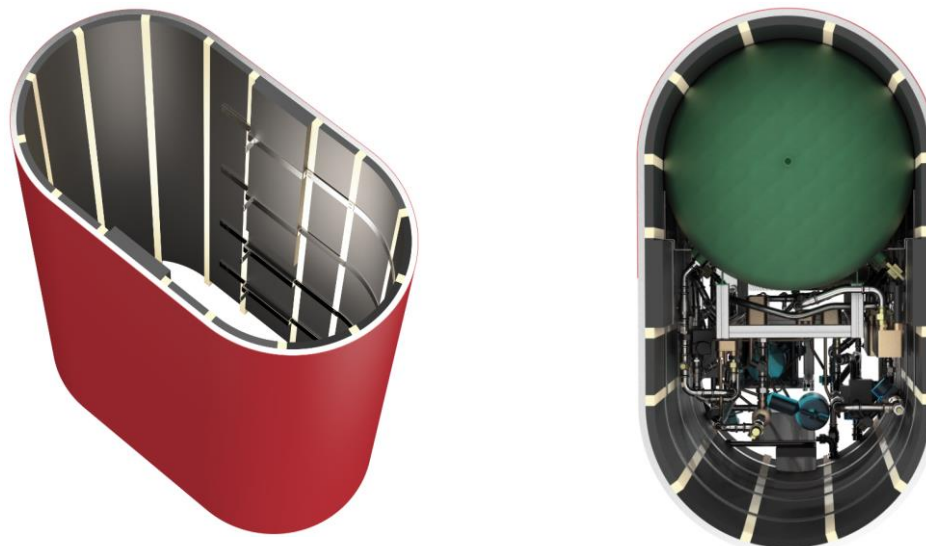

Figure 1: Design of the insulation of the system shown without hydraulic components (left) and with components (right).

Figure 2 shows the square view diagram [1] of the system concept. The main functionality of the system can be described as follows: The heat source of the heat pump - in this particular case - are selective unglazed collectors. If the collector temperature level is high enough and the heat pump is not running, the collectors can load the storage directly. However, it is possible to modify the heat pump source by minor hydraulic changes to a ground source heat pump system, PVT, or ice storage system, alternatively. The heat pump cycle is equipped with a speed controlled compressor and with an additional suction port for vapour injection via an economizer cycle with a plate heat exchanger. A Desuperheater is used to transfer heat from the superheated refrigerant vapor to water for DHW preparation at relatively high temperatures as a by-product of space heating operation. The water side of the condenser is connected to the space heating loop. This is mainly charged directly by the heat pump, without using the storage. Also if enough solar energy is stored in the combi-storage, the

space heating can be loaded directly by the tank. For the hot water preparation a domestic hot water module is used. More details on control and the system concept can be found in [2].

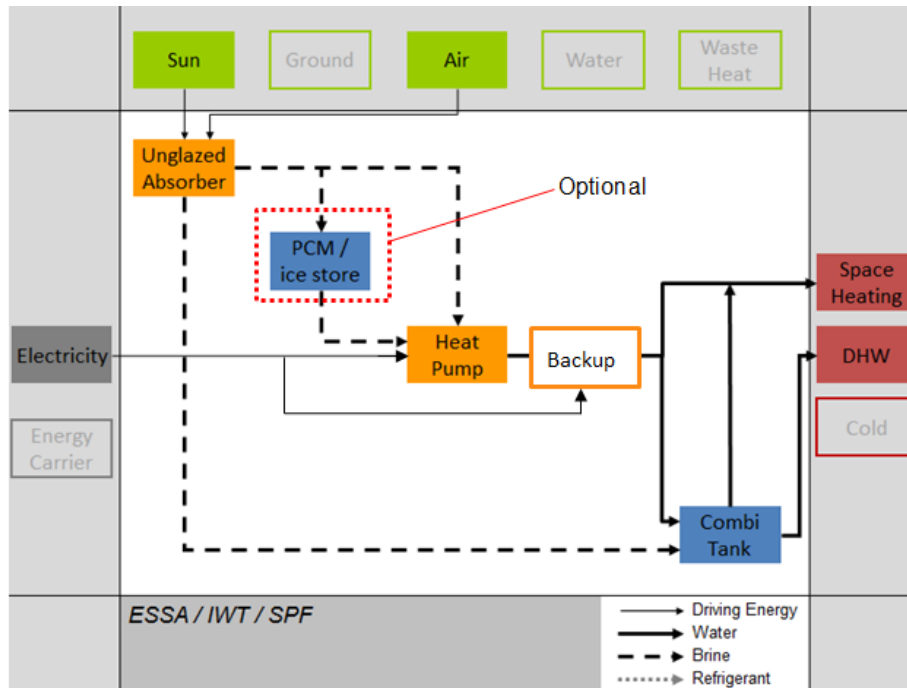

Figure 2: Square view diagram of the concept developed by ESSA, IWT and SPF [1].

METHOD

General

Within the first and second phase of the MacSheep project in the year 2012, breakthroughs for materials, components and control that lead to higher energetic performance and/or lower cost of the system were analysed and selected. The effect of potential breakthroughs on the energetic performance was determined by annual simulations. In phase three of the project (2013-2014) the promising breakthroughs were built into real components and tested in the laboratories. The test results were used to validate and calibrate the component models for the annual simulation. In phase four of the project (2015) a whole system test method will be used to test the complete system and confirm the energetic performance and functionality of the overall system. All performance results are compared with a state of the art solar – heat pump system which is available on the market and which has been tested with the whole system test method in the first year of the project [3].

Simulation

The annual whole system simulation was done with TRNSYS 17. The following components of the system were built and tested in the laboratory separately: unglazed selective collector, heat pump, combi-storage and the domestic hot water module. With the results from the component testing the simulation was validated and calibrated to get realistic results for the whole system. Table 1 shows the main components and their key figures.

Two different climates and two different buildings have been simulated and compared with the reference system. The building heat load (SH) and the domestic hot water demand (DHW) were based on IEA Task44/Annex38 [8] for a single family house (SFH) with 45 kWh/(m²a)

and a retrofit house with 100 kWh/(m²a). Details about the boundary conditions and the reference system can be found in [2].

Component	Size	Type	Parameters	TRNSYS Model
Collector	26 m ²	Unglazed Selective Collector	$\eta_0 = 0.954 [-]$ $b_0 = 0.01 [s/m]$ $b_1 = 11.96 [W/(m^2K)]$ $b_2 = 2.904 [W/(m^2K^2)]$ $\alpha = 0.917 [-]$ $\varepsilon = 0.26 [-]$	Type 202 [4]
Heat Pump	Heating Power 4.9 kW / B0W35 @ 3600 rpm	Variable Speed, Economizer, Desuperheater	COP 4.0 / B0W35	Type 877 [5]
Storage Tank	Volume 750 l	Combi Storage	Heat Losses 3.91 kWh/day (Whole Store at 60°C, not including all hydraulics)	Type 1924 [6]
Solar Heat Exchanger	1.22 m ²	External Flat Plate	U _A -Value 3135 W/K	Type 5b
DHW Heat Exchanger	0.95 m ²	External Flat Plate	U _A -Value 3914 W/K	Type 805 [7]

Table 1: Key components summarized with their key figures.

Testing

A new harmonized dynamic system test method for heating systems was developed and will be applied by the institutes SERC and SP from Sweden, INES from France and SPF from Switzerland. The new method combines the advantages of the different methods that existed before the MacSheep project. The new method is a benchmark test, which means that the load for space heating and domestic hot water preparation is identical for all tested systems, and that the result is representative for the performance of the system over a whole year. Thus, no modelling and simulation of the tested system is needed in order to obtain the benchmark results for a yearly cycle. This is a significant step forward, since the method is now also applicable to products for which simulation models are not available yet. More information and details about the dynamic system test method can be found in [3]. The new developed heat pump was tested under steady state conditions, whereby 58 measuring points were recorded. Additionally to the steady state measurements, dynamic tests with varying operating conditions were carried out. These results were used to validate and parametrize the simulation model of the heat pump.

RESULTS

Heat Pump

Table 2 shows the results of the steady state heat pump measurements for different realistic operating conditions. The results show that with very low source temperatures ($T_{\text{brine,in}}$) of -15 °C and condenser water outlet temperature of 34 °C ($T_{\text{cond,out}}$) the heat pump still achieves a COP of 2.8. Even at higher condenser water outlet temperatures (48 °C) for DHW

preparation a COP of 2.3 can be reached. These remarkable results can be explained with the implementation of the economizer cycle. However, for the most time of the year much higher brine temperatures can be expected, leading to higher COP's between 4.4 and 5.9. Dynamic test results can be found in [9].

n_{comp}	T_{brine,in}	T_{cond,in}	T_{cond,out}	T_{DES,out}	Q_{cond,sh}	Q_{DES,dhw}	P_{el}	COP
[rpm]	[°C]	[°C]	[°C]	[°C]	[kW]	[kW]	[kW]	[-]
4800 a)	-15	45	48.1	92	3.0	1.9	2.20	2.3
5400 b)	-15	30	34	80	3.9	1.2	1.85	2.8
3000 b)	2	23	28	58	3.9	0.5	0.88	5.0
2400 b)	2	30	33	62	3.0	0.6	0.81	4.4
2400 b)	15	30	34	57	3.9	0.6	0.77	5.9

Table 2: Results of the steady state heat pump measurements for different operating points.

a) domestic hot water preparation, b) space heating mode with parallel preparation of domestic hot water (desuperheater)

Whole System Simulation

Table 3 summarizes the results from the annual system simulations with validated parameters of the components. The difference to the reference system is shown in brackets. The key figures here are the seasonal performance factor (SPF) of the whole system, the electricity use ($W_{el,SHP+}$) including the electricity demand of controller, valves and pumps, according to the definitions of the IEA SHC Task 44 [8]. Also the design flow temperature (T_{FI}) and the design return temperature (T_{Rt}) of the heating distribution are shown. The results show for both climates and heat loads a significant improvement. A further interesting result is that the heat pump in the annual simulation for Zurich SFH45 shows only 21 activations for direct DHW charging (the rest is covered by solar and the desuperheater), which leads to an annual heat pump SPF of 4.03.

	Zurich SFH45	Zurich SFH100	Carcassonne SFH45	Carcassonne SFH100
SPF _{SHP+} [-]	4.48 (+40.5 %)	3.21 (+32.0 %)	5.16 (+34 %)	4.01 (+36.9 %)
W _{el,SHP+} [MWh]	2.52 (-28.8 %)	6.28 (-24.7 %)	1.15 (-30.6 %)	2.82 (-30.5 %)
T _{FI} / T _{Rt} [°C]	35 / 30	55 / 45	35 / 30	55 / 45

Table 3: Key performance figures for the optimized system, with difference compared to reference system given in brackets (the new system is optimized and designed for Zurich SFH45).

CONCLUSION

The obtained results (HP) from the daily tests (dynamic) and static tests show a satisfying performance of the heat pump prototype and its control. Also the vacuum insulation shell, the storage stratification, the new absorber development, and the hydraulic concept show very promising results. All these components combined and simulated in an annual simulation

show that the goals of the project (-25 % electricity demand) can be achieved or even exceeded. Thanks to the hydraulic concept in combination with the direct solar energy contribution to the storage and the desuperheater loop, exclusive DHW charging by the heat pump can be reduced significantly to 21 times per year, compared to common heat pump systems which have 1 – 2 charging cycles per day. This leads to a very good annual HP SPF because the heat pump does not have to work with high condensation temperatures. The heat losses of the storage system seem high with 3.91 kWh/day, but it has to be considered that the outer insulation surface area is almost doubled compared to common storages, and that this includes at the same time the heat losses of all component of the heat pump, solar pump group, and hydraulics.

While this paper is written the MacSheep system is prepared for the whole system test in the SPF test bench. The final results are expected in autumn 2015 and will be published by end of the year 2015.

ACKNOWLEDGEMENTS

The research leading to these results has received funding from the European Union's Seventh Framework Programme FP7/2007-2013 under grant agreement n° 282825 – Acronym MacSheep.

REFERENCES

1. Frank, E., Haller, Y. M., Herkel, S. & Ruschenburg, J., Systematic Classification of Combined Solar Thermal and Heat Pump Systems. In: Proc. of the EuroSun Conference, Graz, Austria, 2010.
2. Bales, C. et al.: Optimized Solar and Heat Pump Systems, Components and Dimensioning. MacSheep Deliverable 7.3, <http://macsheep.spf.ch>, 2014.
3. Haberl, R. et al.: Testing of Combined Heating Systems for Small Houses: Improved Procedures for Whole System Test Methods. MacSheep Deliverable 2.3, <http://macsheep.spf.ch>, 2015.
4. Bertram, E., Glembin, J., Scheuren, J., Rockendorf, G.: Condensation Heat Gains on Unglazed Solar Collectors in Heat Pump Systems. In: Proc. of the EuroSun Conference, Graz, Austria, 2010.
5. Heinz, A., Haller, Y. M.: Appendix A3 - Description of TRNSYS Type 877 by IWT and SPF. In: Models of Sub-Components and Validation for the IEA SHC Task 44 / HPP Annex 38 - Part C: Heat Pump Models - DRAFT - A technical report of subtask C Deliverable C2.1 Part C, 2012.
6. Haller Y. M., & Carbonell, D.: TRNSYS Type 1924 v3.1 - Stratified Plug Flow Solar Combi-Store Model. Institute for Solar Technology SPF, Switzerland, 2014.
7. Haller, Y. M.: TRNSYS Type 805 "DHW Heat Exchanger without Heat Losses". Institute of Thermal Engineering IWT, Austria, 2006.
8. Haller, .Y. M., Dott, R., Ruschenburg, J., Ochs, F. and Bony, J.: IEA-SHC Task 44 Subtask C technical report: The Reference Framework for System Simulations of the IEA SHC Task 44 / HPP Annex 38: Part A: General Simulation Boundary Conditions, IEA-SHC, Paris, www.iea-shc.org/task44, 2012.
9. Heinz, A. et al.: Final Report on Heat Pump Developments in WP 4. Macsheep Deliverable 4.4, <http://macsheep.spf.ch>, 2014.