

# Tunable and reconfigurable multi-tap microwave photonic filter based on dynamic Brillouin gratings in fibers

J. Sancho,<sup>1,\*</sup> N. Primerov,<sup>2</sup> S. Chin,<sup>2</sup> Y. Antman,<sup>3</sup> A. Zadok,<sup>3</sup> S. Sales,<sup>1</sup> and L. Thévenaz<sup>2</sup>

<sup>1</sup>*iTEAM Institute, Universidad Politécnica de Valencia, 46022 Valencia, Spain*

<sup>2</sup>*Ecole Polytechnique Fédérale de Lausanne, Institute of Electrical Engineering, SCI-STI-LT Station 11, 1015 Lausanne, Switzerland*

<sup>3</sup>*Faculty of Engineering, Bar-Ilan University, Ramat-Gan 52900 Israel*

\*[juasandu@upvnet.upv.es](mailto:juasandu@upvnet.upv.es)

**Abstract:** We propose and experimentally demonstrate new architectures to realize multi-tap microwave photonic filters, based on the generation of a single or multiple dynamic Brillouin gratings in polarization maintaining fibers. The spectral range and selectivity of the proposed periodic filters is extensively tunable, simply by reconfiguring the positions and the number of dynamic gratings along the fiber respectively. In this paper, we present a complete analysis of three different configurations comprising a microwave photonic filter implementation: a simple notch-type Mach-Zehnder approach with a single movable dynamic grating, a multi-tap performance based on multiple dynamic gratings and finally a stationary grating configuration based on the phase modulation of two counter-propagating optical waves by a common pseudo-random bit sequence (PRBS).

©2012 Optical Society of America

**OCIS codes:** (070.1170) Analog optical signal processing; (290.5900) Scattering, stimulated Brillouin; (060.4370) Nonlinear optics, fibers.

## References and links

1. A. Seeds, "Microwave photonics," *IEEE Trans. Microw. Theory Tech.* **50**(3), 877–887 (2002).
2. J. Capmany and D. Novak, "Microwave photonics combines two worlds," *Nat. Photonics* **1**(6), 319–330 (2007).
3. J. Capmany, B. Ortega, D. Pastor, and S. Sales, "Discrete-time optical processing of microwave signals," *J. Lightwave Technol.* **23**(2), 702–723 (2005).
4. J. Yao, "Microwave photonics," *J. Lightwave Technol.* **27**(3), 314–335 (2009).
5. R. A. Minasian, "Photonic signal processing of microwave signals," *IEEE Trans. Microw. Theory Tech.* **54**(2), 832–846 (2006).
6. R. W. Boyd and D. J. Gauthier, "Slow and fast light," *Ch. 6 in Progress in Optics* **43**, E. Wolf, ed. (Elsevier, Amsterdam, 2002), 497–530.
7. J. Mørk, R. Kjør, M. van der Poel, and K. Yvind, "Slow light in a semiconductor waveguide at gigahertz frequencies," *Opt. Express* **13**(20), 8136–8145 (2005).
8. H. Su, P. Kondratko, and S. L. Chuang, "Variable optical delay using population oscillation and four-wave-mixing in semiconductor optical amplifiers," *Opt. Express* **14**(11), 4800–4807 (2006).
9. K. Y. Song, M. Herráez, and L. Thévenaz, "Observation of pulse delaying and advancement in optical fibers using stimulated Brillouin scattering," *Opt. Express* **13**(1), 82–88 (2005).
10. S. Chin, N. Primerov, and L. Thevenaz, "Photonic delay line for broadband optical signals, based on dynamic grating reflectors in fibers," 2010 36th European Conference and Exhibition on Optical Communication - (ECOC 2010), Torino, Italy, (2010).
11. N. Primerov, S. Chin, K. Song, and L. Thevenaz, "Ultra wide range tunable delay line using dynamic grating reflectors in optical fibers," in *Optical Fiber Communication Conference, OSA Technical Digest (CD)* (Optical Society of America, 2010), paper OWF6.
12. K. Y. Song, W. Zou, Z. He, and K. Hotate, "All-optical dynamic grating generation based on Brillouin scattering in polarization-maintaining fiber," *Opt. Lett.* **33**(9), 926–928 (2008).
13. K. Y. Song and H. J. Yoon, "Observation of narrowband intrinsic spectra of Brillouin dynamic gratings," *Opt. Lett.* **35**(17), 2958–2960 (2010).
14. K. Y. Song, S. Chin, N. Primerov, and L. Thevenaz, "Time-domain distributed fiber sensor with 1 cm spatial resolution based on Brillouin dynamic grating," *J. Lightwave Technol.* **28**(14), 2062–2067 (2010).
15. R. W. Boyd, *Nonlinear Optics*, 3rd ed. (Academic Press, 2008).

## 1. Introduction

The interface between microwave engineering and optical signal processing is designated as Microwave Photonics (MWP) [1-2], an emergent area of research which enables the generation, transport and processing of radio frequency (RF), microwave and millimeter-wave signals directly in the optical domain [3-4]. One of the exciting motivations within the MWP field is attributed to its potential application to implement wideband reconfigurable filters [4]. One architecture for MWP filters that is prevalent in the literature relies on discrete-time processing [3-5]: delayed replicas of an optical wave, which is modulated by a microwave signal, are weighed and summed to obtain a desired finite impulse response. Discrete time processing is often restricted to an incoherent summation of intensities, due to phase instabilities in optical paths, which would limit the attainable filter responses to those of positive coefficients only. Variable optical delay elements are key components in MWP filter implementations. Aiming at developing reliable MWP based filtering implementations, the efficient design of broadband and tunable delay lines is of key importance [5]. Among the wide diversity of optical delay line schemes that have been reported over the last decade [6-8], slow and fast light (SFL) has proved to be one potential approach to generate continuously tunable signal delays. However, the maximum achievable time delay in all SFL systems is essentially restricted by the delay-bandwidth product [9].

Recently, a novel method to generate long variable optical delays of broadband signals has been proposed [10-11]. It makes use of stimulated Brillouin scattering (SBS) interaction between two pumps that are co-polarized along one principal axis of a polarization maintaining fiber (PMF) [12-14]. The interaction generates a so-called dynamic Brillouin grating (DBG), which in turn could reflect incoming probe signals that are polarized along the orthogonal principal axis. DBGs are essentially optical wave reflectors that can be created at any preset position along the entire PMF. The phase of the reflected waveform is inherently stable, since Brillouin reflections are phase conjugated [15]. Therefore, variable-position DBGs are an attractive platform for the construction of MWP filters.

In this work, we demonstrate three different schemes for the realization of MWP filters using DBGs. The location of the dynamic gratings along a PMF is controlled by proper temporal coding on the pump waves. The first configuration is a simple notch-type Mach-Zehnder (MZ) approach, whereby the delay imbalance between the two arms is tuned using one movable grating along the PMF. A multi-tap performance is demonstrated in the second configuration, where the combined reflections from multiple DBGs along a PMF are employed. In both these approaches, local DBGs are introduced using pulsed pumps. However, such gratings decay according to the finite acoustic lifetime [14] and must be periodically refreshed. To overcome this limitation, a novel technique for the generation of localized and stationary DBGs has been used in the third implementation of MWP filters. The method relies on phase modulation of the two pump waves by a common, high-rate pseudo-random bit sequence (PRBS) [16].

## 2. Experimental setup and principle

A generic experimental layout of a DBG-based MWP filter is illustrated in Fig. 1. A distributed-feedback laser diode (DFB-LD 1) is used to generate the two pump waves. The laser source is split into distinct fiber channels. The power in the upper channel is boosted using an erbium-doped fiber amplifier (EDFA) up to ~200 mW, polarized along the slow axis of the PMF, and hereafter designated as Pump 1. Light in the other channel is modulated by an electro-optic intensity modulator  $EOM_1$  driven by a microwave signal at the Brillouin shift frequency  $\nu_B$  (~11 GHz). The  $EOM_1$  is biased in order suppress the optical carrier. The upper sideband is selected using a narrow-band fiber Bragg grating (FBG) and then amplified by a second EDFA to ~200 mW to be used as Pump 2. This way the stability of the frequency difference between the two pumps is automatically secured. The polarization of Pump 2 is

also aligned along the slow axis before entering the opposite end of the fiber. The signal wave source of a second DFB laser (DFB-LD 2) is modulated by an RF tone from the output port of a vector network analyzer (VNA) using EOM<sub>2</sub>, amplified and polarized along the fast axis of the PMF. According to the high birefringence of the PMF, the dynamic grating resonance appears at 73 GHz above the frequency of Pump 2, hence the optical frequency of DFB-LD 2 has to be precisely placed at the center of the DBG using temperature and current controls. The reflected signal is finally detected and measured by the input port of the VNA.

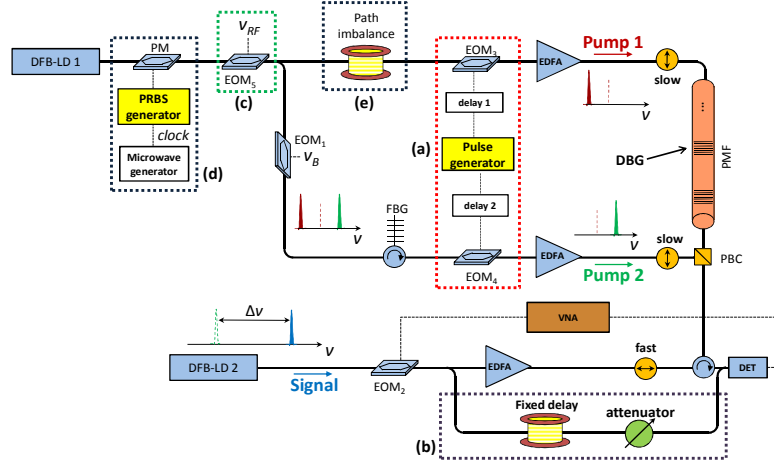

Fig. 1. Experimental setup to realize MWP filters, using a single or multiple dynamic Brillouin grating reflectors.

Three distinct filter configurations have been accomplished by successively implementing different variations in the setup. In configuration n° 1 and n° 2, both Brillouin pump signals are pulse shaped using the EOM<sub>3</sub> and EOM<sub>4</sub>, as shown in Fig. 1(a). The relative time delay between the two pumps is accurately set to place the DBG at any desired position along the PMF. In configuration n° 1, a single grating is generated along the PMF, playing the role of a simple reflector delaying the signal. Thus, a fixed delaying arm in the signal channel must be added to build up the filter in a MZ configuration, as shown in Fig. 1 (b).

In configuration n° 2, multiple dynamic gratings are generated along the PMF and each grating reflection is equivalent to an individual tap. So, the fixed arm used as a second tap is no longer required. In addition, in this configuration the DFB-LD 1 is externally modulated by the EOM<sub>5</sub> (Fig. 1(c)) at an RF frequency of  $\nu_{RF}$ , with its bias set to completely suppress the carrier. This way, double dynamic gratings can be generated at a same position in fibers, reflecting signal optical frequencies that are separated by  $2\nu_{RF}$ . This arrangement helps to increase the bandwidth of the filters, as will be discussed later.

In configuration n° 3, the laser output is modulated through a phase modulator (PM) driven by a common pseudo-random bit sequence (PRBS) generator as shown in Fig. 1(d), and the building blocks of insets 1(a), 1(b) and 1(c) are removed for this implementation. DBGs are generated at periodic discrete locations, in which the modulated pumps are correlated. A path imbalance is added in Pump 1 arm (Fig. 1(e)), so that high-order correlation peaks are obtained along the PMF [16]. The correlation peaks are scanned by changing the clock rate of the PRBS generator [16].

The transfer function of a Finite Impulse Response (FIR) filter can be expressed as [5]

$$H(\omega) = \sum_{r=0}^{N-1} a_r e^{-j\omega r \Delta T},$$

where  $a_r$  denotes coefficient of each filter tap that can be real or complex,  $\omega$  the angular frequency and  $\Delta T$  the basic delay. The response period or free spectral range (FSR) is inversely related to that elementary delay between adjacent filter contributions ( $FSR = 1/\Delta T$ ). Thus, the FSR tunability in a transversal filter implementation relies on dynamic control of

$\Delta T$ , and the reconfigurability can be also accomplished simply by increasing the number of coefficients, hence the number of dynamic grating reflectors.

### 3. Experimental results

#### 3.1 MWP filter configuration n° 1

The DBG is generated through interaction between two counter-propagating Brillouin pump pulses. The acoustic wave builds up at the crossing point as long as the pulses physically overlap and then gradually decays [12]. It means that the dynamic grating needs to be periodically regenerated at the same position. The repetition rate of both Brillouin pumps is adjusted at 5 ns, which is shorter than the acoustic lifetime ( $\sim 10$  ns) [12] to be sure that the grating is refreshed before it vanishes. According to this repetition rate, the gratings are periodically created along the fiber with a periodicity of 2.5 ns due to the crossing counter-propagative configuration. This periodicity is longer than the 2 ns transit time through the 40 cm PMF used in this configuration. It assures that only one dynamic grating is present along the fiber. The spectral bandwidth of the DBG is determined by its physical length, and hence by the pulse duration of the Brillouin pumps [11]. The pumps pulses were Gaussian shaped with a full width at half maximum (FWHM) of 400 ps, corresponding to a DBG reflectivity bandwidth that is far broader than 1 GHz. This figure is of importance since the bandwidth of the grating acts as an actual limitation in terms of instantaneous bandwidth of the MWP filter.

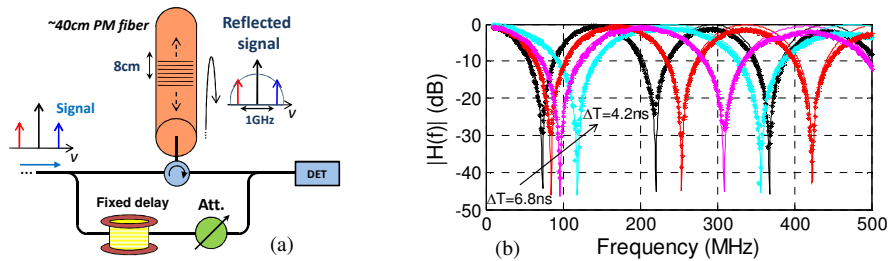

Fig. 2. (a) Basic filter layout and (b) frequency response of the two-tap filter implementation in configuration n°1.

Figure 2(a) depicts the basic layout of the filter in configuration n° 1. The original RF-modulated signal from the fixed arm is combined with the reflected replica from the moveable dynamic grating to generate a two-tap filter response. Changes to the DBG position modified the relative delay  $\Delta T$  between the two paths, and the FSR of the filter response. Since the optical carrier and both sidebands are reflected by the same grating, the operating frequency of the filter is limited to the half of the grating bandwidth, on the order of 500 MHz in this case. A  $\sim 80$  m-long optical fiber is introduced as a fixed delay in one branch of the layout to compensate the fiber length of several optical components, such as EFDA, circulator and couplers. The fixed path also provides a length imbalance of  $\sim 1$  m between the two taps.

Figure 2(b) shows the measured notch-type frequency response of the filter obtained for different grating position. The experimental filter responses (symbols) are in good agreement with calculated estimations (solid lines). We attribute the small deviation observed at high frequencies to the finite bandwidth of the dynamic grating, since the reference tap, i.e. the fixed path, exhibits a constant frequency response. The relative delay between the fixed and variable paths was changed from 4.2 ns to 6.8 ns, corresponding to continuous FSR variation of up to 62%. The maximum delay variation is limited by the PMF length. The response can be reconfigured with additional parallel taps, however such scaling is rather complicated. In addition, both the bandwidth and central frequency of this filter configuration are restricted to the order of 1 GHz.

#### 3.2 MWP filter configuration n° 2

Configuration no. 2 is based on the generation of multiple dynamic gratings along the fiber. Thus, the spectral response of the filter results from the combination of multiple reflections

with different time delays, which is ideally equivalent to a multi-tap filter configuration with identical and positive weights [3]. The number of taps comprising the filter is readily reconfigurable by simply changing the number of dynamic grating reflectors generated in the fiber. Due to the unique feature of phase conjugation in Brillouin scattering [15], all delayed RF signals from different gratings remains in phase, resulting in no coherence restraints. To enhance the RF baseband frequency response, and to demonstrate the high flexibility of the configuration, Brillouin pumps were modulated to eventually consist of two different optical frequencies separated by  $2\nu_{RF}$  (see Fig. 1(c) and Fig. 3(a)). This way the carrier wave of the signal matches the resonance of one DBG, whereas one of its sidebands is in resonance with a second DBG which is overlapping in position. While the filter bandwidth remains on the order of 1 GHz, its central frequency is arbitrarily adjusted through  $\nu_{RF}$ . The central frequency is only restricted by the bandwidth of the modulators and driving equipment.

The relative frequencies of the Brillouin pumps and the modulated signal are shown in Fig. 3(a), while a simplified layout of the filter architecture is illustrated in Fig. 3(b). The frequency responses of different number of dynamic gratings (2, 3 and 4) created along 110 cm-long PMF are demonstrated in Figs. 3(c), 3(d) and 3(e), respectively. The power reflectivity of the DBGs was on the order of  $-35$  dB. Our filter thus works in low reflectance regime, and hence the interfering contribution due to multiple reflections is negligible. In this particular type of implementation, the Q factor only depends on the number of taps comprising the filter and the grating reflectance has no impact on this quality factor [3]. For a two-tap configuration, we could change the repetition rate of pump pulses from 4 ns to 6.6 ns, corresponding to a 65% change of the FSR, while preserving the bandwidth. The length of the PMF restricted the FSR variations of the higher-order filters: 17% for three DBGs, and practically none for four. Birefringence uniformity along the PMF is critical to achieve equal taps, since the signal frequency of maximum reflectivity varies with birefringence. We believe that birefringence non-uniformity explains the mismatch between experimental results and theoretical calculations, especially when the number of coefficients is increased.

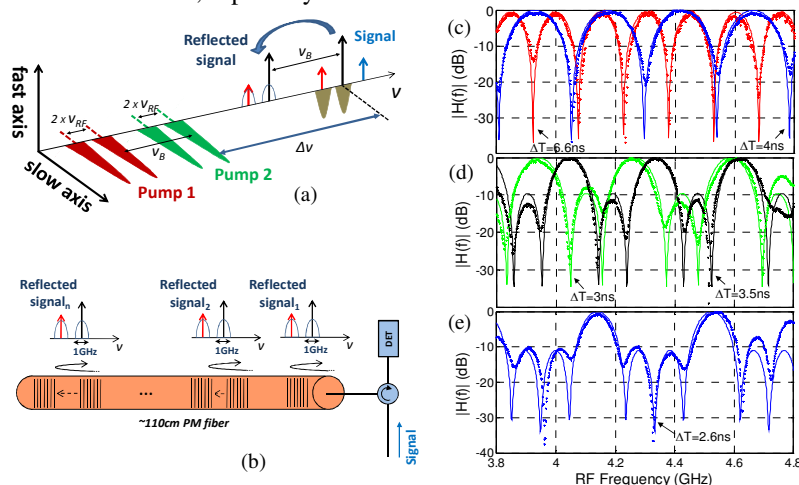

Fig. 3. (a) Optical frequencies location, (b) basic filter layout and (c)-(e) frequency response of the two-tap, three-tap and four-tap MWP filter in configuration 2.

### 3.3 MWP filter configuration $n^{\circ} 3$

Unlike the previous configurations, here the two Brillouin pumps are shaped to deliver constant power, but their optical phases are externally modulated through an electro-optic phase modulator driven by a PRBS generator. In this configuration, the stimulated Brillouin scattering interaction between the two pumps is efficiently restricted to narrow regions where their phases are steadily correlated. This way stationary DBGs are obtained, whose length matches the spatial extent of a single modulation bit [16]. However, stationary gratings appear

with a periodicity that equals half the PRBS word length, hence multiple gratings can be implemented along a single PMF to realize multi-tap MWP filters, as shown in Fig. 4(a).

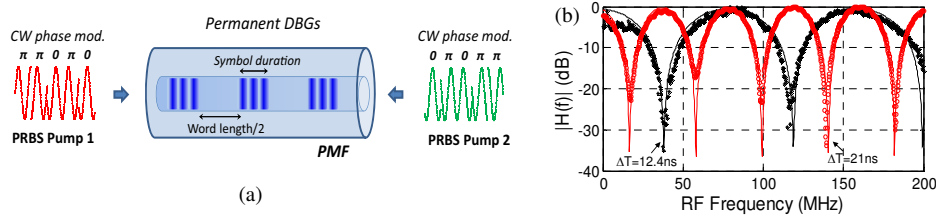

Fig. 4. (a) Generation of stationary dynamic gratings using PRBS phase modulation. (b) Spectral response of two-tap MWP filter.

In this experiment, a 2m-long PMF was used as a delaying medium and the modulation frequency of PRBS was varied between 6 and 10 GHz with 127 bits word length, which is the lowest available in our generator. Two correlation peaks could be created along the PMF with a relative delay in the range of 12.7 – 21 0.1 ns. The FSR of the resulting MWP notch filter ranged between 47 and 78 MHz, a variation of 66%, as shown in Fig. 4(b).

The DBGs obtained using this methods are stationary and do not require periodic refreshing every  $\tau$ . Therefore, the restriction of the relative delay to the order of  $\tau$  is removed. On the other hand, the continuous power of the pumps used in this technique is much lower than the peak power of the pump pulses that were used before. Since the strength of the DBG reflection scales quadratically with the pump power, the stationary DBGs tend to be considerably weaker than pulsed ones.

#### 4. Conclusions

We have designed and experimentally demonstrated three different configurations to realize multi-tap MWP filters, based on dynamic Brillouin grating reflectors in polarization maintaining fibers. The spectral responses of the proposed novel variety of filters can be dynamically tuned and reconfigured, by simply changing the characteristics of single or multiple DBG generations, showing a FSR variation larger than 60% in a two-tap filter. The first configuration allows for any spectral range tunability, however the number of taps and the central frequency could not be scaled. MWP filters based on configurations n° 2 and n° 3 were based on multiple grating reflectors successively created along the same fiber, and the need of a reference tap with a fixed optical delay line could be eliminated. The filter FSR is governed by the number of taps and the fiber length: large FSRs require short and precise fiber lengths. In these configurations the birefringence uniformity along the fiber must be carefully inspected for a consistent frequency response. Some stability issues were found related to changes in the physical properties of the fiber. Yet, the fiber can be properly isolated. In the second configuration, two distinct dynamic Brillouin gratings were localized at the same position, so that the resonance frequency of one grating could match the incident optical carrier and another could reflect one of the two modulation sidebands. This way we could extend the central operation frequency of the filter beyond that of configuration n° 1. Lastly, the correlation technique based on the external PRBS optical phase modulation proposed in configuration n° 3 enables the generation of stationary DBGs. These alleviate the need for periodic refreshing, help extend the range of attainable FSRs, and improve the tunability and the scalability of the filter response.

#### Acknowledgments

The authors wish to acknowledge the financial support of the European Community's Seventh Framework Programme (FP 7) project GOSPEL; the GVA PROMETEO 2008/092, Infraestructura FEDER UPVOV08-3E-008, the Plan Nacional I + D TEC2011-29120-C05-05, the Swiss National Science Foundation through project 200021-134546 and the EPFL Space Center, the Israeli Science Foundation (ISF), and the KAMIN program of the Chief Scientist Office, Israel Ministry of Industry, Trade and Labor.